



THE DATASHEET OF INA2132UA





Dual, Low Power, Single-Supply DIFFERENCE AMPLIFIER

FEATURES

- DESIGNED FOR LOW COST
- LOW QUIESCENT CURRENT:
160 μ A per Amplifier
- WIDE POWER SUPPLY RANGE:
Single Supply: 2.7V to 36V
Dual Supplies: ± 1.35 V to ± 18 V
- LOW GAIN ERROR: $\pm 0.05\%$ max
- LOW NONLINEARITY: 0.001% max
- HIGH CMRR: 90dB
- HIGHLY VERSATILE CIRCUIT
- EASY TO USE
- SO-14 PACKAGE

DESCRIPTION

The INA2132 is a dual low power, unity-gain difference amplifier offering excellent value at very low cost. Each channel consists of a precision op amp with a laser-trimmed precision resistor network, providing accurate gain and high common-mode rejection. Excellent TCR tracking of the resistors maintains gain accuracy and common-mode rejection over temperature. The internal op amp's common-mode range extends to the negative supply—ideal for single-supply applications.

The difference amplifier is the foundation of many commonly used circuits. The INA2132 provides this circuit function without using an expensive precision resistor network. The INA2132 is available in the SO-14 surface-mount package and is specified for operation over the extended industrial temperature range, -40°C to $+85^{\circ}\text{C}$.

A single version of this product with similar specifications is also available. See the INA132 data sheet for details.

APPLICATIONS

- DIFFERENTIAL INPUT AMPLIFIER
- INSTRUMENTATION AMPLIFIER BUILDING BLOCK
- UNITY-GAIN INVERTING AMPLIFIER
- $G = 1/2$ AMPLIFIER
- $G = 2$ AMPLIFIER
- SUMMING AMPLIFIER
- DIFFERENTIAL CURRENT RECEIVER
- VOLTAGE-CONTROLLED CURRENT SOURCE
- BATTERY-POWERED SYSTEMS
- GROUND LOOP ELIMINATOR

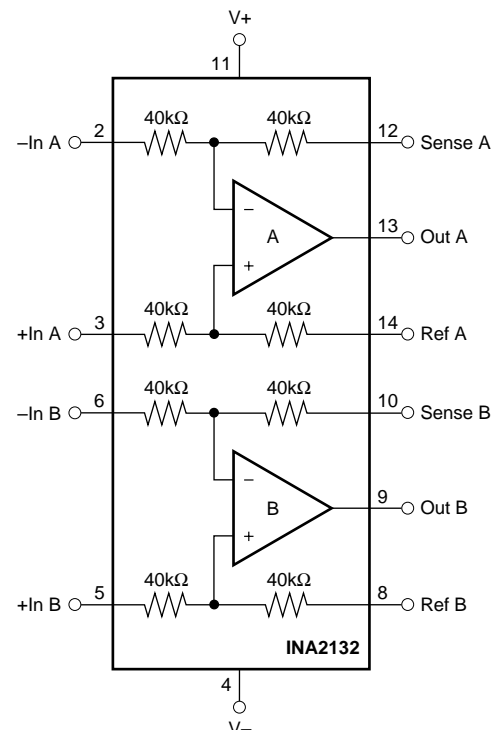

SPECIFICATIONS: $V_S = \pm 15V$

At $T_A = +25^\circ C$, $R_L = 10k\Omega$ connected to ground, and reference pins connected to ground unless otherwise noted.

PARAMETER	CONDITIONS	INA2132U			INA2132UA			UNITS
		MIN	TYP	MAX	MIN	TYP	MAX	
OFFSET VOLTAGE⁽¹⁾	RTO							
Initial V_{OS}			± 75	± 250		*	± 500	μV
vs Temperature dV_{OS}/dT			± 1	± 5		*	± 10	$\mu V/^\circ C$
vs Power Supply PSRR	$V_S = \pm 1.35V$ to $\pm 18V$		± 5	± 30		*	*	$\mu V/V$
vs Time			0.3			*		$\mu V/mo$
Channel Separation ⁽²⁾	dc		0.04			*		$\mu V/V$
INPUT IMPEDANCE⁽³⁾								
Differential			80			*		$k\Omega$
Common-Mode			40			*		$k\Omega$
INPUT VOLTAGE RANGE								
Common-Mode Voltage Range ⁽⁴⁾	$V_O = 0V$	2 (V-)		2 (V+) -2	*		*	V
Common-Mode Rejection Ratio CMRR	$V_{CM} = -30V$ to $28V$, $R_S = 0\Omega$	80	90		74	*		dB
OUTPUT VOLTAGE NOISE⁽⁵⁾	RTO							
f = 0.1Hz to 10Hz			1.6			*		$\mu Vp-p$
f = 1kHz			65			*		nV/\sqrt{Hz}
GAIN								
Initial			1			*		V/V
Error	$V_O = -14V$ to $13.5V$		± 0.01	± 0.05		*	± 0.1	%
vs Temperature			± 1	± 10		*	*	$ppm/^\circ C$
Nonlinearity	$V_O = -14V$ to $13.5V$		± 0.0001	± 0.001		*	± 0.002	% of FS
OUTPUT								
Voltage, Positive	$R_L = 100k\Omega$ to Ground	(V+) -1	(V+) -0.8		*	*		V
Negative	$R_L = 100k\Omega$ to Ground	(V-) +0.5	(V-) +0.15		*	*		V
Positive	$R_L = 10k\Omega$ to Ground	(V+) -1.5	(V+) -0.8		*	*		V
Negative	$R_L = 10k\Omega$ to Ground	(V-) +1	(V-) +0.25		*	*		V
Current Limit, per Amplifier	Continuous to Common		± 12			*		mA
Capacitive Load (stable operation)			10			*		nF
FREQUENCY RESPONSE								
Small-Signal Bandwidth	-3dB		300			*		kHz
Slew Rate	SR		0.1			*		V/ μs
Settling Time: 0.1%	$V_O = 10V$ Step		85			*		μs
0.01%	$V_O = 10V$ Step		88			*		μs
Overload Recovery Time	50% Overdrive		7			*		μs
POWER SUPPLY								
Rated Voltage V_S			± 15			*		V
Voltage Range		± 1.35		± 18	*		*	V
Quiescent Current (per amplifier) I_Q	$I_O = 0mA$		± 160	± 185		*	*	μA
TEMPERATURE RANGE								
Specification		-40		+85	*		*	$^\circ C$
Operation		-55		+125	*		*	$^\circ C$
Storage		-55		+125	*		*	$^\circ C$
Thermal Resistance θ_{JA}			100			*		$^\circ C/W$

* Specifications the same as INA2132U.

NOTES: (1) Includes effects of amplifier's input bias and offset currents. (2) Measured output offset change of one channel for a full-scale swing ($V_O = -14V$ to $13.5V$) on the opposite channel. (3) $40k\Omega$ resistors are ratio matched but have $\pm 20\%$ absolute value. (4) $2 (V-) -V_{REF} < V_{CM} < 2 ((V+) -1) -V_{REF}$. For more detail, see Applications Information section. (5) Includes effects of amplifier's input current noise and thermal noise contribution of resistor network.

The information provided herein is believed to be reliable; however, BURR-BROWN assumes no responsibility for inaccuracies or omissions. BURR-BROWN assumes no responsibility for the use of this information, and all use of such information shall be entirely at the user's own risk. Prices and specifications are subject to change without notice. No patent rights or licenses to any of the circuits described herein are implied or granted to any third party. BURR-BROWN does not authorize or warrant any BURR-BROWN product for use in life support devices and/or systems.

SPECIFICATIONS: $V_S = +5V$ Single Supply

At $T_A = +25^\circ\text{C}$, $R_L = 10\text{k}\Omega$ connected to $V_S/2$, and reference pin connected to $V_S/2$, unless otherwise noted.

PARAMETER	CONDITIONS	INA2132U			INA2132UA			UNITS
		MIN	TYP	MAX	MIN	TYP	MAX	
OFFSET VOLTAGE⁽¹⁾	RTO							
Initial V_{OS} vs Temperature dV_{OS}/dT			± 150 ± 2	± 500		*	± 750	μV $\mu\text{V}/^\circ\text{C}$
INPUT VOLTAGE RANGE								
Common-Mode Voltage Range ⁽²⁾ Common-Mode Rejection CMRR	$V_{CM} = -2.5\text{V to } +5.5\text{V}$, $R_S = 0\Omega$	-2.5 80	90	+5.5	*	*	*	V dB
OUTPUT								
Voltage, Positive Negative Positive Negative	$R_L = 100\text{k}\Omega$ to Ground $R_L = 100\text{k}\Omega$ to Ground $R_L = 10\text{k}\Omega$ to Ground $R_L = 10\text{k}\Omega$ to Ground	(V+) -1 +0.25 (V+) -1 +0.25	(V+) -0.75 +0.06 (V+) -0.8 +0.12		*	*	*	V V V V
POWER SUPPLY								
Rated Voltage V_S Voltage Range Quiescent Current I_Q	$I_O = 0\text{mA}$	+2.7	+5 ± 155	+36 ± 185	*	*	*	V V μA

* Specifications the same as INA2132U.

NOTE: (1) Includes effects of amplifier's input bias and offset currents. (2) $2(V-) - V_{REF} < V_{CM} < 2(V+) - V_{REF}$. For more detail, see Applications Information section.

PIN CONFIGURATION

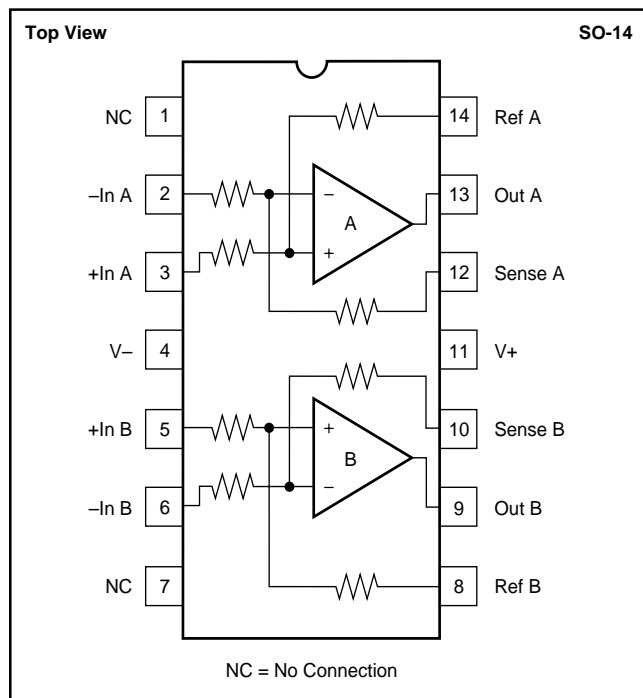

ABSOLUTE MAXIMUM RATINGS

Supply Voltage, $V+$ to $V-$	36V
Input Voltage Range	$\pm 80\text{V}$
Output Short-Circuit (to ground)	Continuous
Operating Temperature	$-55^\circ\text{C to } +125^\circ\text{C}$
Storage Temperature	$-55^\circ\text{C to } +125^\circ\text{C}$
Junction Temperature	$+150^\circ\text{C}$
Lead Temperature (soldering, 10s)	$+300^\circ\text{C}$



ELECTROSTATIC DISCHARGE SENSITIVITY

This integrated circuit can be damaged by ESD. Burr-Brown recommends that all integrated circuits be handled with appropriate precautions. Failure to observe proper handling and installation procedures can cause damage.

ESD damage can range from subtle performance degradation to complete device failure. Precision integrated circuits may be more susceptible to damage because very small parametric changes could cause the device not to meet its published specifications.

PACKAGE/ORDERING INFORMATION

PRODUCT	PACKAGE	PACKAGE DRAWING NUMBER ⁽¹⁾	SPECIFIED TEMPERATURE RANGE	PACKAGE MARKING	ORDERING NUMBER ⁽²⁾	TRANSPORT MEDIA
INA2132U	SO-14 Surface-Mount	235	$-40^\circ\text{C to } +85^\circ\text{C}$	INA2132U	INA2132U	Rails
"	"	"	"	"	INA2132U/2K5	Tape and Reel
INA2132UA	SO-14 Surface-Mount	235	$-40^\circ\text{C to } +85^\circ\text{C}$	INA2132UA	INA2132UA	Rails
"	"	"	"	"	INA2132UA/2K5	Tape and Reel

NOTES: (1) For detailed drawing and dimension table, please see end of data sheet, or Appendix C of Burr-Brown IC Data Book. (2) Models with a slash (/) are available only in Tape and Reel in the quantities indicated (e.g., /2K5 indicates 2500 devices per reel). Ordering 2500 pieces of "INA2132U/2K5" will get a single 2500-piece Tape and Reel. For detailed Tape and Reel mechanical information, refer to Appendix B of Burr-Brown IC Data Book.

TYPICAL PERFORMANCE CURVES

At $T_A = +25^\circ\text{C}$ and $V_S = \pm 15\text{V}$, unless otherwise noted.

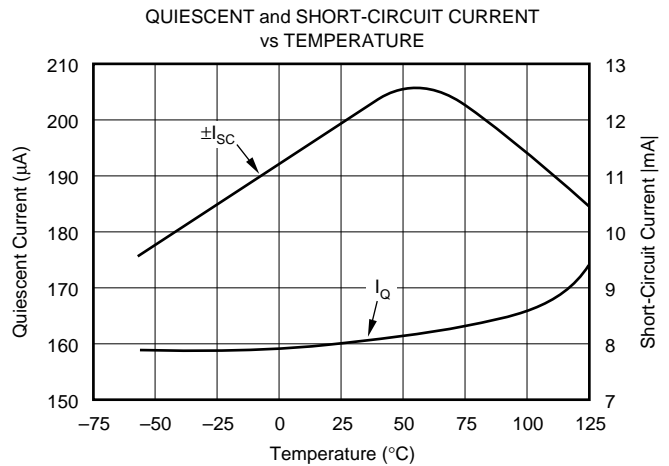
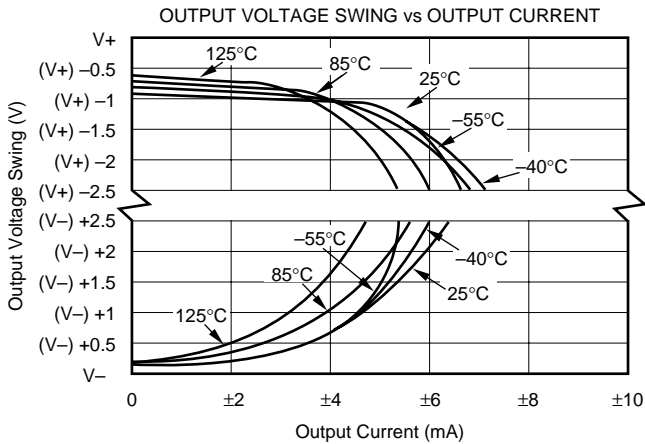
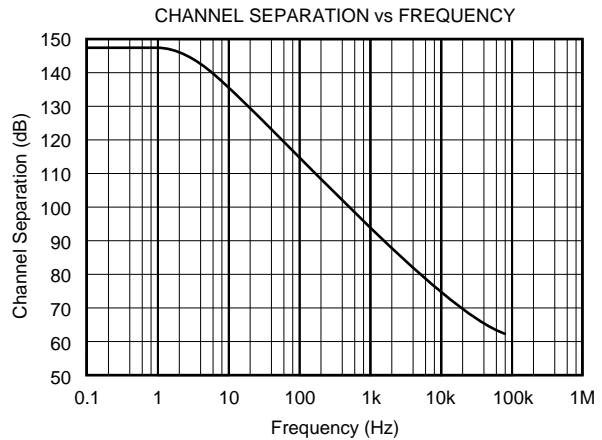
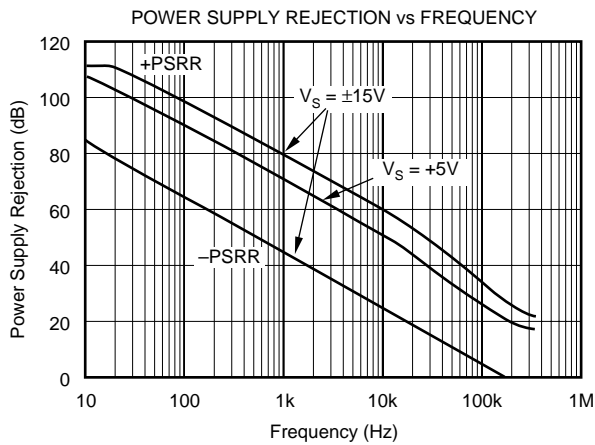
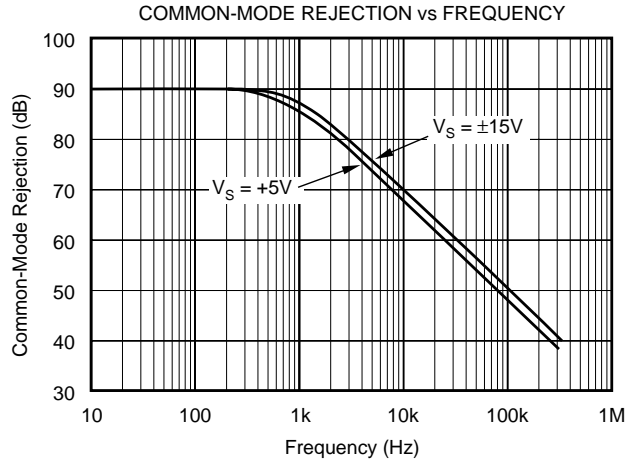
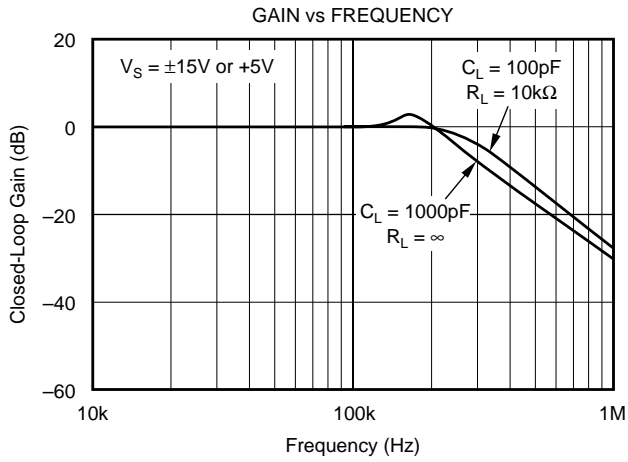

TYPICAL PERFORMANCE CURVES (CONT)

At $T_A = +25^\circ\text{C}$ and $V_S = \pm 15\text{V}$, unless otherwise noted.

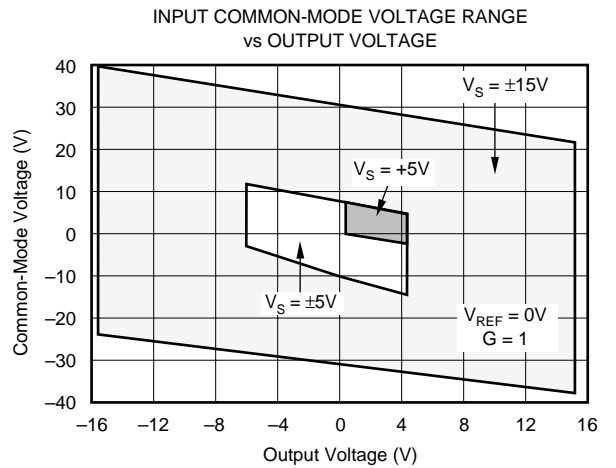
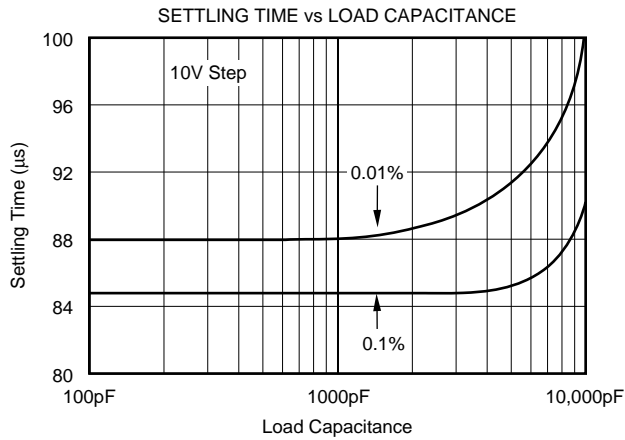
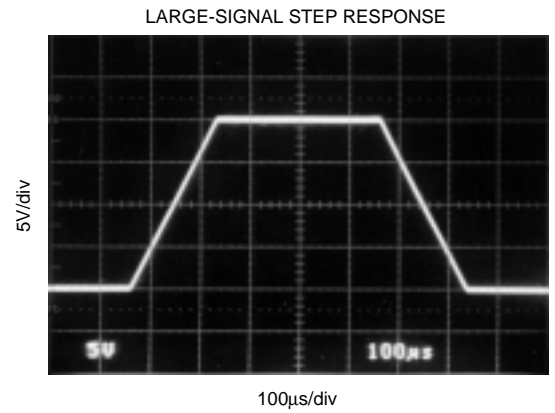
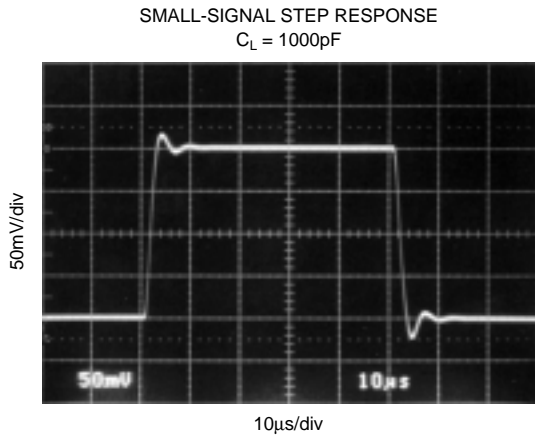
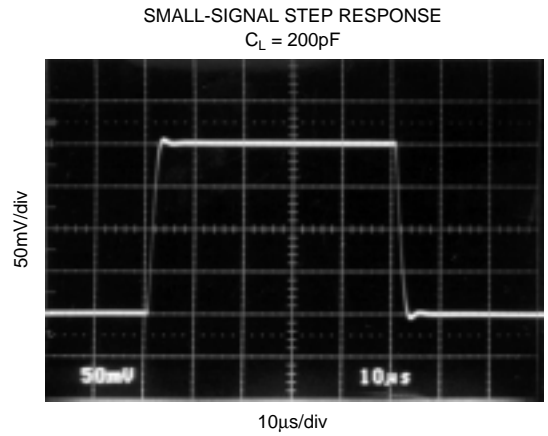
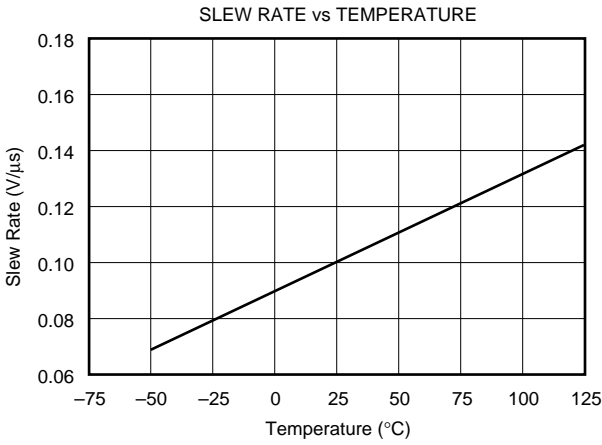

TYPICAL PERFORMANCE CURVES (CONT)

At $T_A = +25^\circ\text{C}$ and $V_S = \pm 15\text{V}$, unless otherwise noted.

0.1Hz to 10Hz PEAK-TO-PEAK
VOLTAGE NOISE

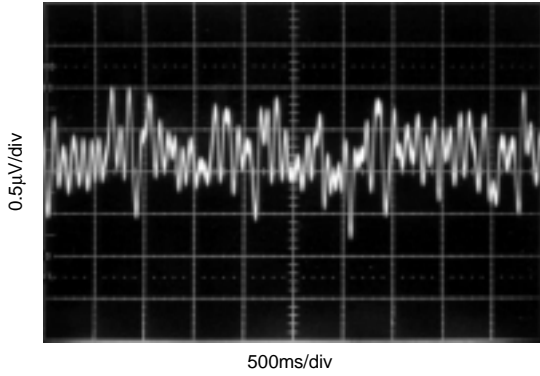

OFFSET VOLTAGE
PRODUCTION DISTRIBUTION

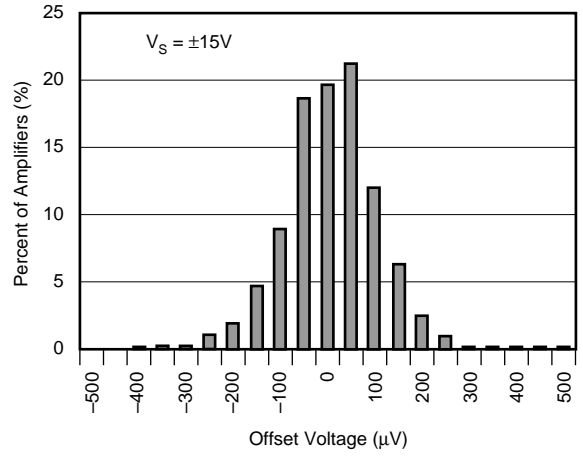

OFFSET VOLTAGE
PRODUCTION DISTRIBUTION

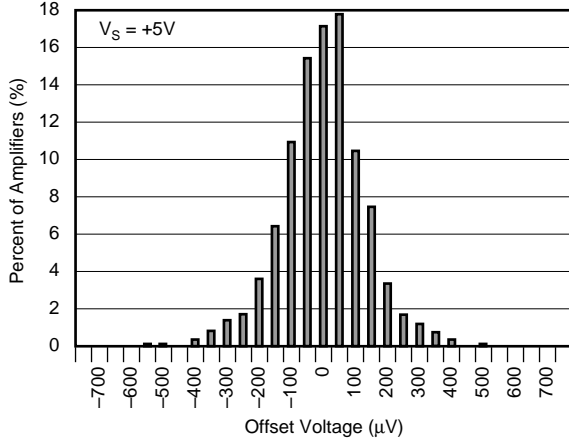

OFFSET VOLTAGE DRIFT
PRODUCTION DISTRIBUTION

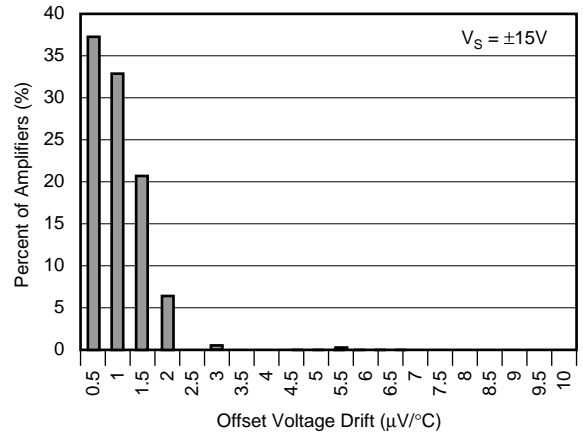

APPLICATIONS INFORMATION

Figure 1 shows the basic connections required for operation of the INA2132. Power supply bypass capacitors should be connected close to the device pins.

The differential input signal is connected to pins 2 and 3 (or pins 6 and 5) as shown. The source impedances connected to the inputs must be nearly equal to assure good common-mode rejection. An 8Ω mismatch in source impedance will degrade the common-mode rejection of a typical device to approximately 80dB. Gain accuracy will also be slightly affected. If the source has a known impedance mismatch, an additional resistor in series with one input can be used to preserve good common-mode rejection.

Do not interchange pins 3 and 14 (or pins 5 and 8) or pins 2 and 12 (or pins 6 and 10), even though nominal resistor values are equal. These resistors are laser-trimmed for precise resistor ratios to achieve accurate gain and highest CMRR. Interchanging these pins may not provide specified performance. As shown in Figure 1, sense line should be connected as close to the load as possible.

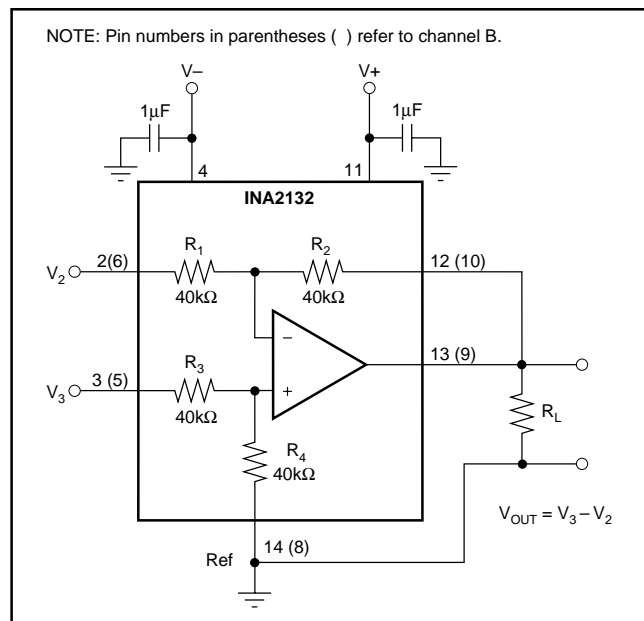

FIGURE 1. Basic Power Supply and Signal Connections.

To ensure valid operation of the differential amplifier, please note the following points:

- 1) $V_{OUT} = V_3 - V_2 + V_{REF}$
- 2) V_{OUT} must be within the specified linear range. For example, with $\pm 15V$ supplies and a 100kΩ load, the output will be defined by:

$$(V-) + 0.15V < V_{OUT} < (V+) - 0.8V$$

- 3) Input common-mode range at the nodes of the op amp must be $V- \leq V_{CM} \leq (V+) - 1$. To ensure that the inputs to the differential amp (+In and -In) meet this criteria, limit the common-mode voltage inputs to:

$$2 \cdot (V-) - V_{REF} < V_{CM} < 2 \cdot ((V+) - 1) - V_{REF}$$

In the case where V_{REF} is grounded, the equation simplifies to:

$$2 \cdot (V-) < V_{CM} < 2 \cdot ((V+) - 1)$$

For more information, see the typical performance curve titled “Input Common-Mode Voltage Range vs Output Voltage.”

OPERATING VOLTAGE

The INA2132 operates from single (+2.7V to +36V) or dual ($\pm 1.35V$ to $\pm 18V$) supplies with excellent performance. Specifications are production tested with +5V and $\pm 15V$ supplies. Most behavior remains unchanged throughout the full operating voltage range. Parameters which vary significantly with operating voltage are shown in the Typical Performance Curves.

The INA2132 can accurately measure differential signals that are beyond the power supply rails. Linear common-mode range extends to twice the negative power supply voltage and nearly twice the positive power supply voltage. Output phase reversal does not occur when the inputs to the internal operational amplifier are overloaded to either rail. See typical performance curve, “Common-Mode Range vs Output Voltage.”

OFFSET VOLTAGE TRIM

The INA2132 is laser-trimmed for low offset voltage and drift. Most applications require no external offset adjustment. Figure 2 shows an optional circuit for trimming the output offset voltage. The output is referred to the output reference terminal (pin 14 or pin 8), which is normally grounded. A voltage applied to the Ref terminal will be summed with the output signal. This can be used to null offset voltage. The source impedance of a signal applied to the Ref terminal should be less than 8Ω to maintain good common-mode rejection. To assure low impedance at the Ref terminal, the trim voltage can be buffered with an op amp, such as the OPA277.

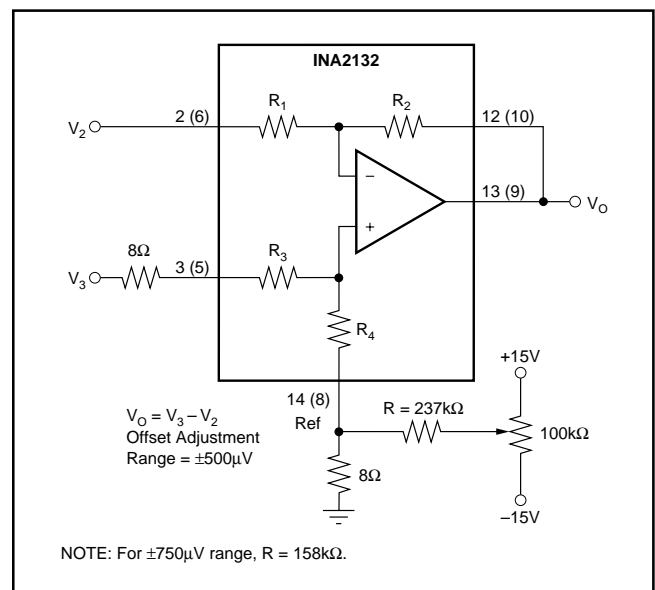

FIGURE 2. Offset Adjustment.

CAPACITIVE LOAD DRIVE CAPABILITY

The INA2132 can drive large capacitive loads, even at low supplies. It is stable with a 10nF load. Refer to the “Small-Signal Step Response” and “Settling Time vs Load Capacitance” typical performance curves.

CHANNEL CROSSTALK

The two channels of the INA2132 are completely independent, including all bias circuitry. At dc and low frequency, there is virtually no signal coupling between channels. Crosstalk increases with frequency and is dependent on source impedance and signal characteristics. See the typical performance curve “Channel Separation vs Frequency” for more information.

Most crosstalk is produced by capacitive coupling of signals from one channel to the input section of the other channel. To minimize coupling, separate the input traces as far as practical from any signals associated with the opposite channel. A grounded guard trace surrounding the inputs helps reduce stray coupling between channels. Run the differential inputs of each channel parallel to each other or

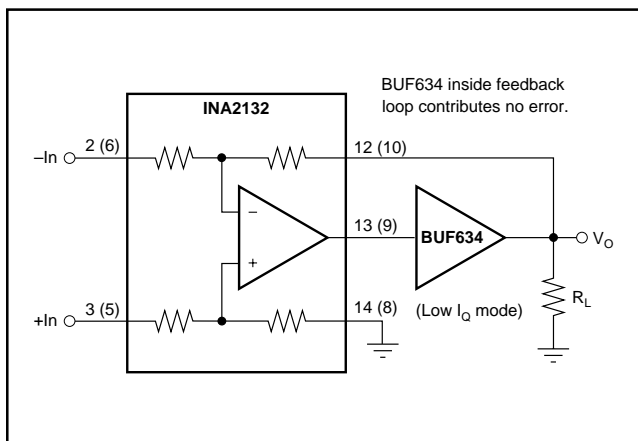

FIGURE 3. Low Power, High Output Current Precision Difference Amplifier.

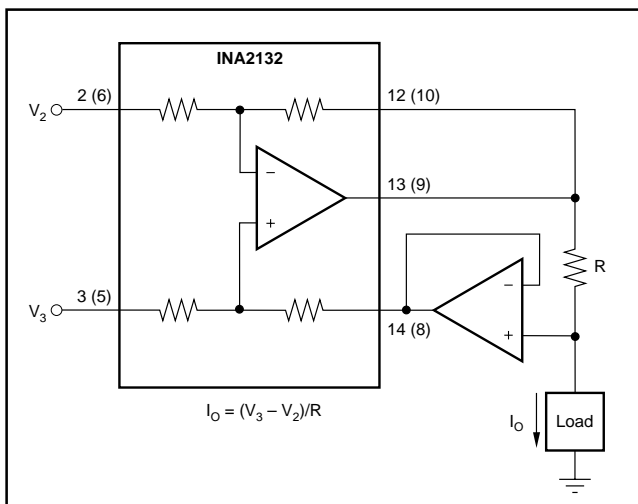

FIGURE 4. Differential Input Voltage-to-Current Converter for Low I_{OUT} .

directly adjacent on the top and bottom sides of a circuit board. Stray coupling then produces a common-mode signal which is rejected by the INA2132’s input.

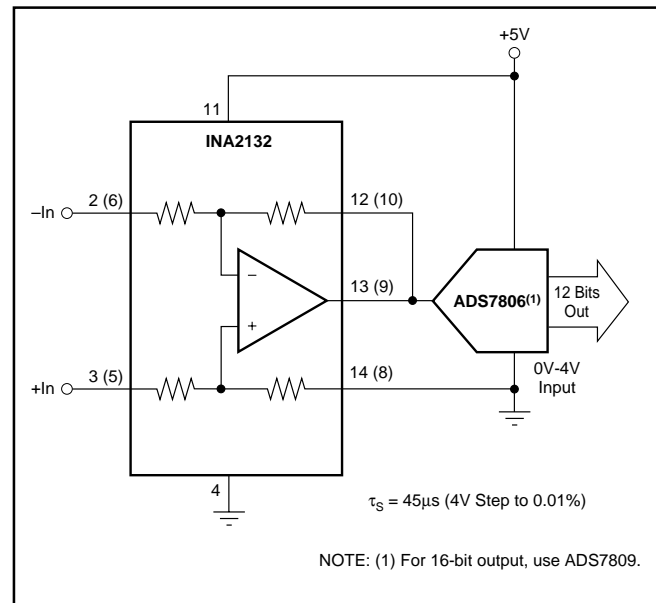

FIGURE 5. Differential Input Data Acquisition.

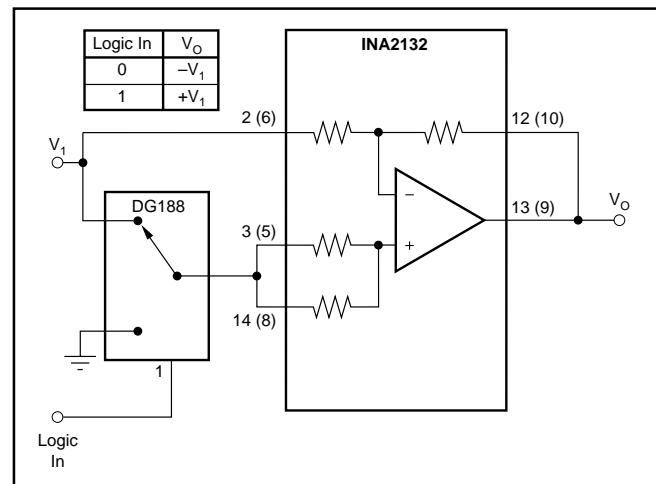

FIGURE 6. Digitally Controlled Gain of ± 1 Amplifier.

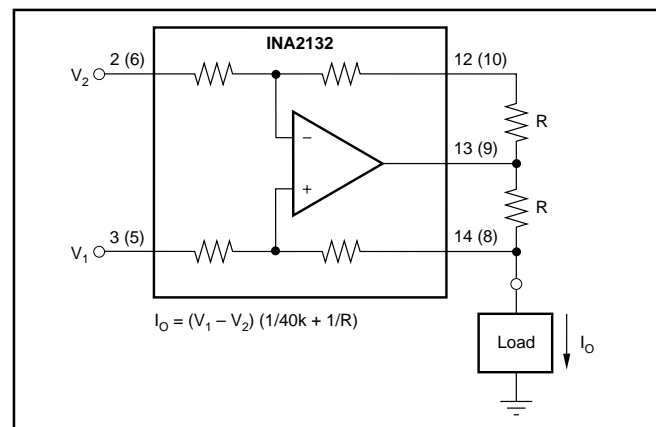

FIGURE 7. Precision Voltage-to-Current Converter with Differential Inputs.

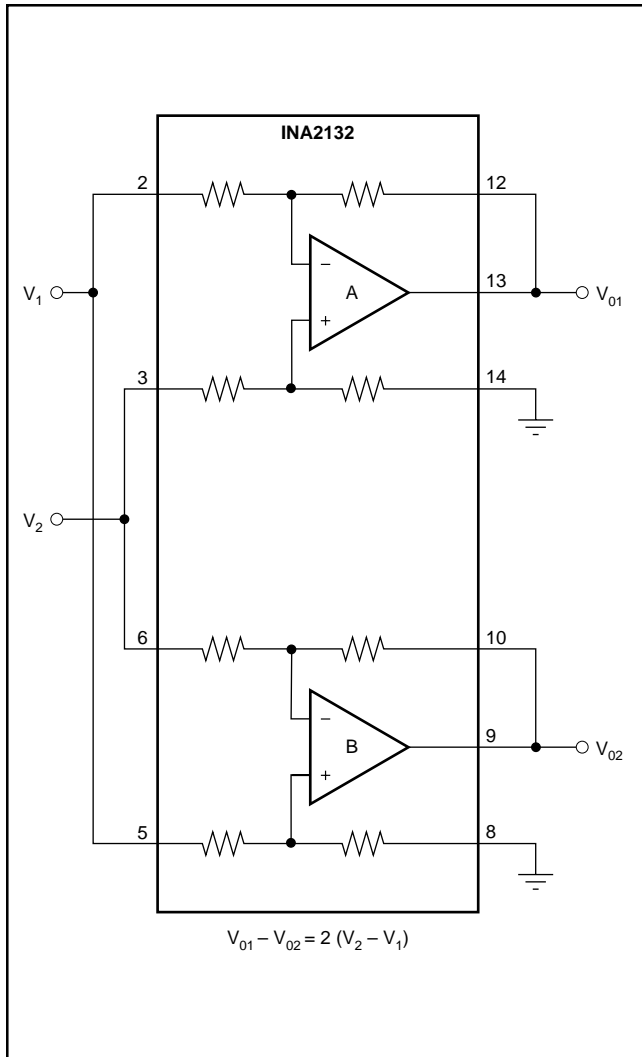

FIGURE 8. Differential Output Difference Amplifier.

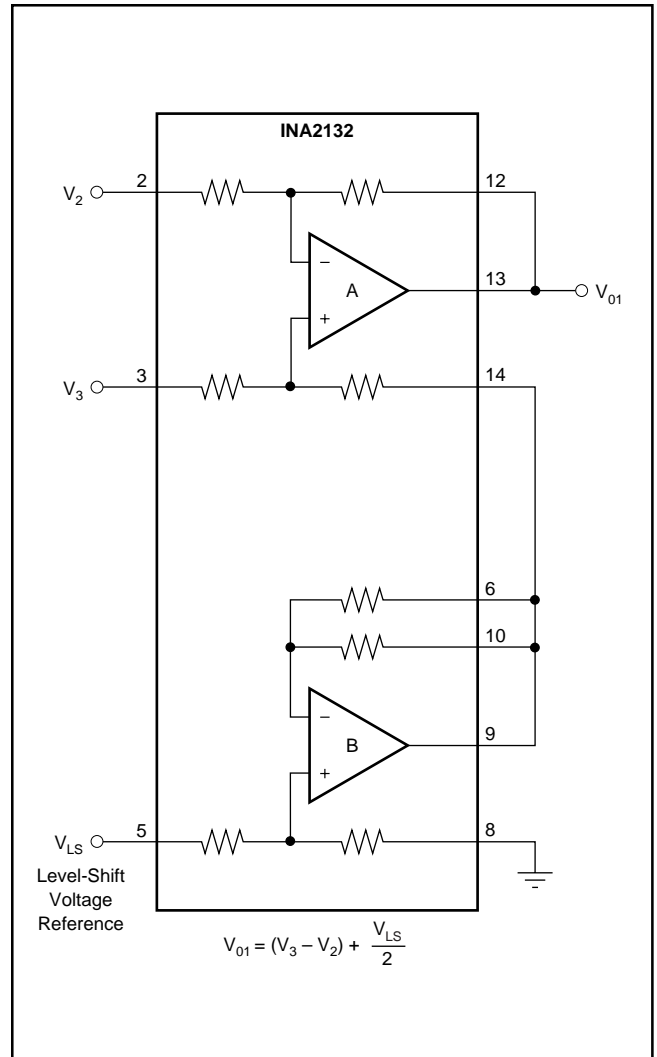

FIGURE 9. Precision Level Shifter.

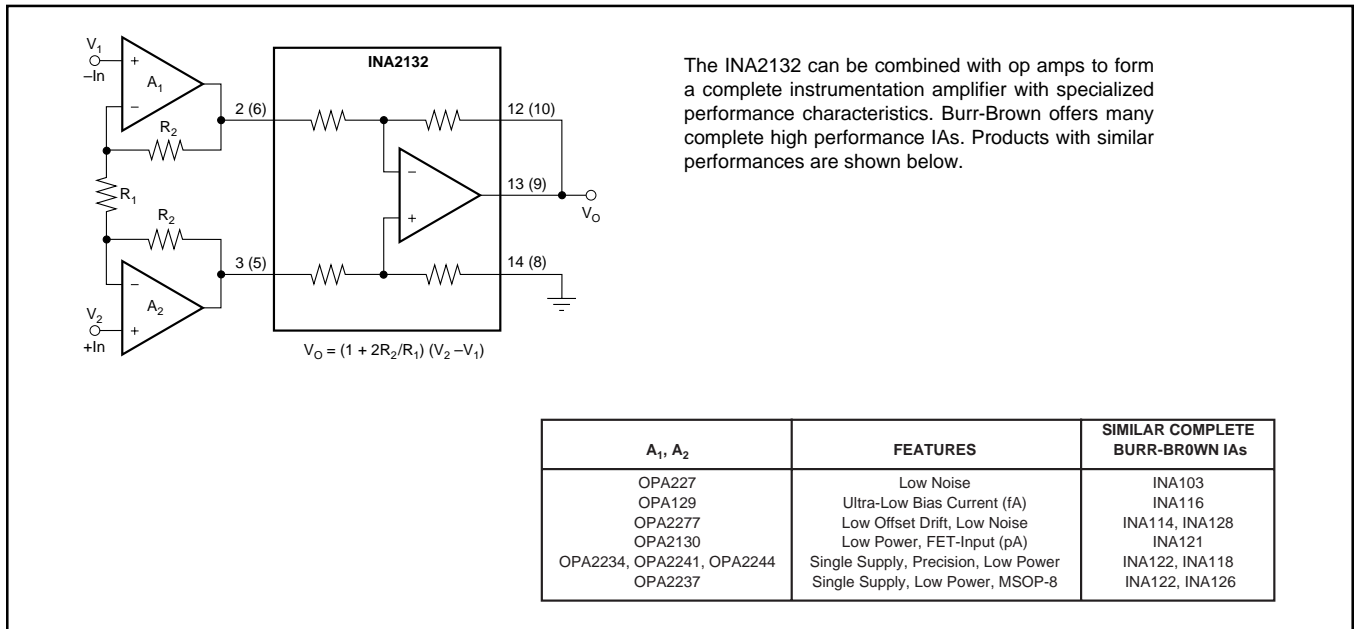

FIGURE 10. Precision Instrumentation Amplifier.

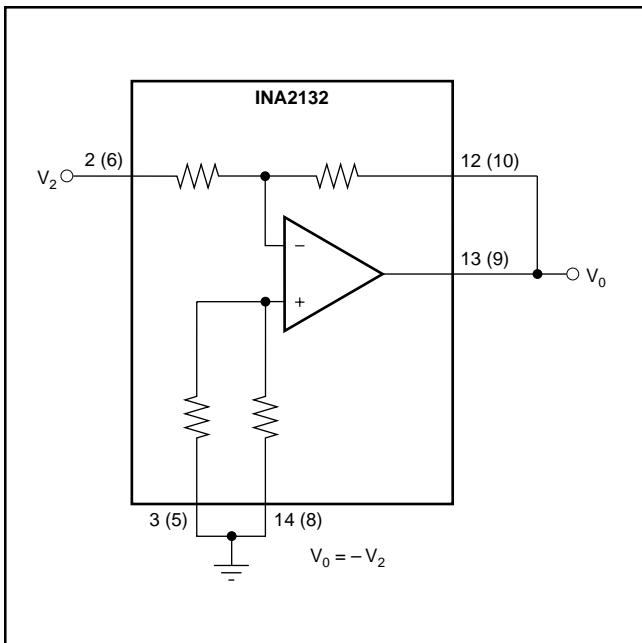

FIGURE 11. Precision Inverting Unity-Gain Amplifier.

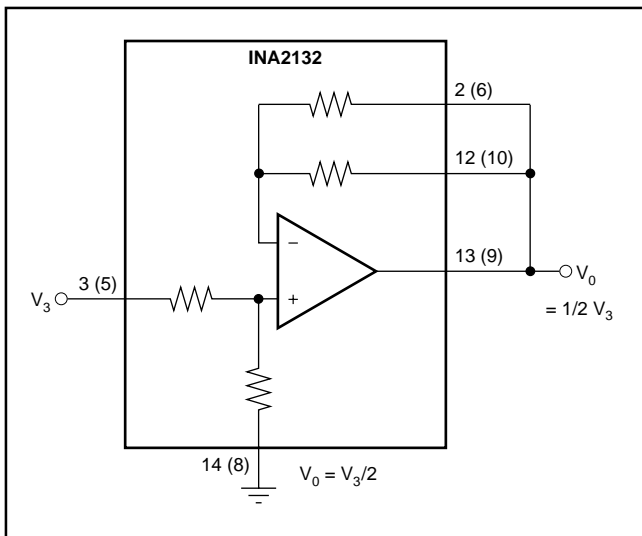

FIGURE 12. Precision Gain = 1/2 Amplifier.

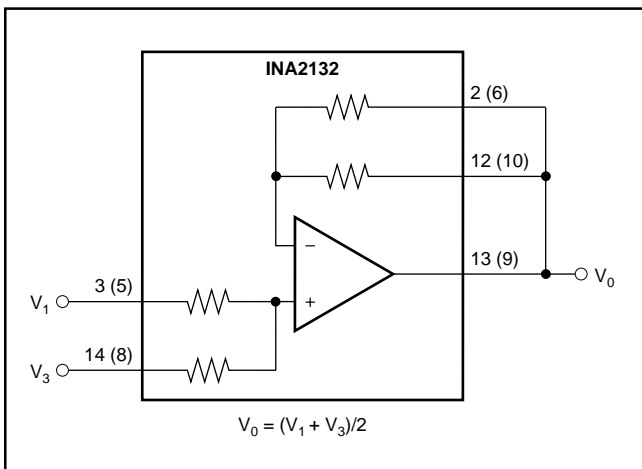

FIGURE 13. Precision Average Value Amplifier.

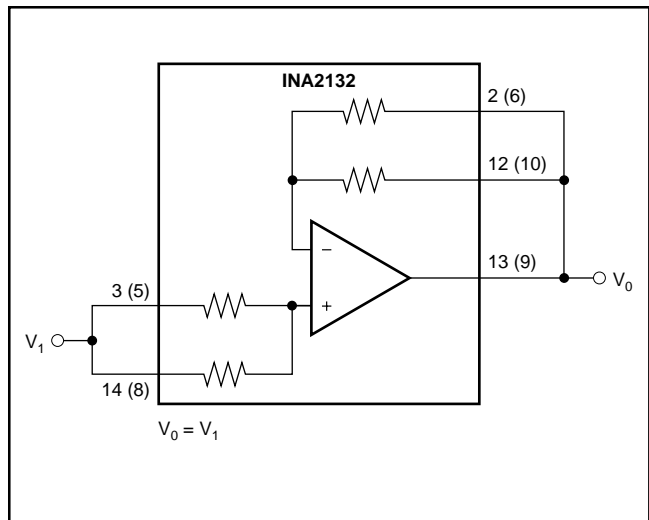

FIGURE 14. Precision Unity-Gain Buffer.

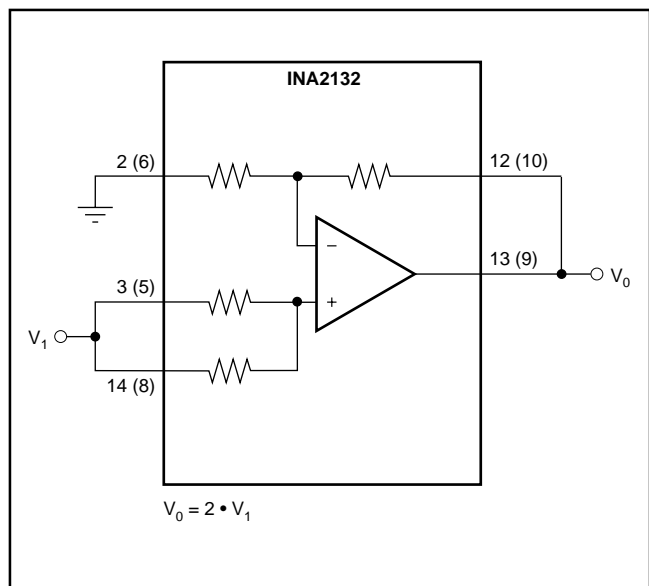

FIGURE 15. Precision Gain = 2 Amplifier.

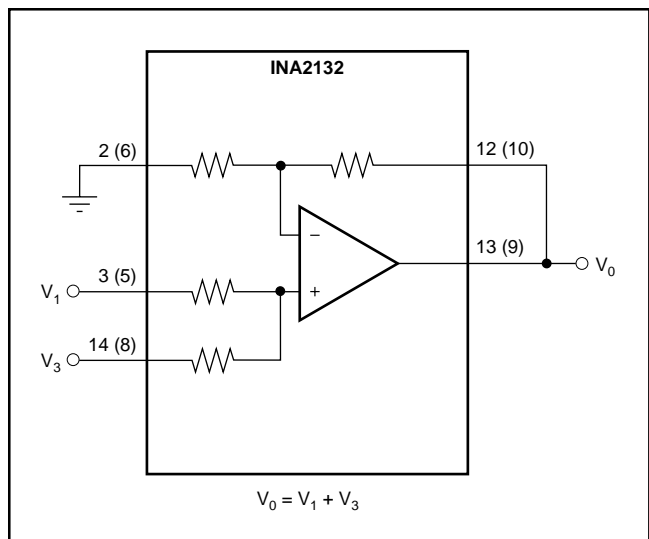

FIGURE 16. Precision Summing Amplifier.

PACKAGING INFORMATION

Orderable Device	Status (1)	Package Type	Package Drawing	Pins	Package Qty	Eco Plan (2)	Lead/Ball Finish (6)	MSL Peak Temp (3)	Op Temp (°C)	Device Marking (4/5)	Samples
INA2132U	ACTIVE	SOIC	D	14	50	Green (RoHS & no Sb/Br)	CU NIPDAU	Level-3-260C-168 HR	-40 to 85	INA2132U A	Samples
INA2132U/2K5	ACTIVE	SOIC	D	14	2500	Green (RoHS & no Sb/Br)	CU NIPDAU	Level-3-260C-168 HR	-40 to 85	INA2132U A	Samples
INA2132UA	ACTIVE	SOIC	D	14	50	Green (RoHS & no Sb/Br)	CU NIPDAU	Level-3-260C-168 HR	-40 to 85	INA2132U A	Samples
INA2132UA/2K5	ACTIVE	SOIC	D	14	2500	Green (RoHS & no Sb/Br)	CU NIPDAU	Level-3-260C-168 HR	-40 to 85	INA2132U A	Samples
INA2132UAE4	ACTIVE	SOIC	D	14	50	Green (RoHS & no Sb/Br)	CU NIPDAU	Level-3-260C-168 HR	-40 to 85	INA2132U A	Samples

(1) The marketing status values are defined as follows:

ACTIVE: Product device recommended for new designs.

LIFEBUY: TI has announced that the device will be discontinued, and a lifetime-buy period is in effect.

NRND: Not recommended for new designs. Device is in production to support existing customers, but TI does not recommend using this part in a new design.

PREVIEW: Device has been announced but is not in production. Samples may or may not be available.

OBSOLETE: TI has discontinued the production of the device.

(2) **RoHS:** TI defines "RoHS" to mean semiconductor products that are compliant with the current EU RoHS requirements for all 10 RoHS substances, including the requirement that RoHS substance do not exceed 0.1% by weight in homogeneous materials. Where designed to be soldered at high temperatures, "RoHS" products are suitable for use in specified lead-free processes. TI may reference these types of products as "Pb-Free".

RoHS Exempt: TI defines "RoHS Exempt" to mean products that contain lead but are compliant with EU RoHS pursuant to a specific EU RoHS exemption.

Green: TI defines "Green" to mean the content of Chlorine (Cl) and Bromine (Br) based flame retardants meet JS709B low halogen requirements of <=1000ppm threshold. Antimony trioxide based flame retardants must also meet the <=1000ppm threshold requirement.

(3) MSL, Peak Temp. - The Moisture Sensitivity Level rating according to the JEDEC industry standard classifications, and peak solder temperature.

(4) There may be additional marking, which relates to the logo, the lot trace code information, or the environmental category on the device.

(5) Multiple Device Markings will be inside parentheses. Only one Device Marking contained in parentheses and separated by a "-" will appear on a device. If a line is indented then it is a continuation of the previous line and the two combined represent the entire Device Marking for that device.

(6) Lead/Ball Finish - Orderable Devices may have multiple material finish options. Finish options are separated by a vertical ruled line. Lead/Ball Finish values may wrap to two lines if the finish value exceeds the maximum column width.

Important Information and Disclaimer: The information provided on this page represents TI's knowledge and belief as of the date that it is provided. TI bases its knowledge and belief on information provided by third parties, and makes no representation or warranty as to the accuracy of such information. Efforts are underway to better integrate information from third parties. TI has taken and continues to take reasonable steps to provide representative and accurate information but may not have conducted destructive testing or chemical analysis on incoming materials and chemicals. TI and TI suppliers consider certain information to be proprietary, and thus CAS numbers and other limited information may not be available for release.

In no event shall TI's liability arising out of such information exceed the total purchase price of the TI part(s) at issue in this document sold by TI to Customer on an annual basis.

TAPE AND REEL INFORMATION

QUADRANT ASSIGNMENTS FOR PIN 1 ORIENTATION IN TAPE

*All dimensions are nominal

Device	Package Type	Package Drawing	Pins	SPQ	Reel Diameter (mm)	Reel Width W1 (mm)	A0 (mm)	B0 (mm)	K0 (mm)	P1 (mm)	W (mm)	Pin1 Quadrant
INA2132U/2K5	SOIC	D	14	2500	330.0	16.4	6.5	9.0	2.1	8.0	16.0	Q1
INA2132UA/2K5	SOIC	D	14	2500	330.0	16.4	6.5	9.0	2.1	8.0	16.0	Q1

TAPE AND REEL BOX DIMENSIONS

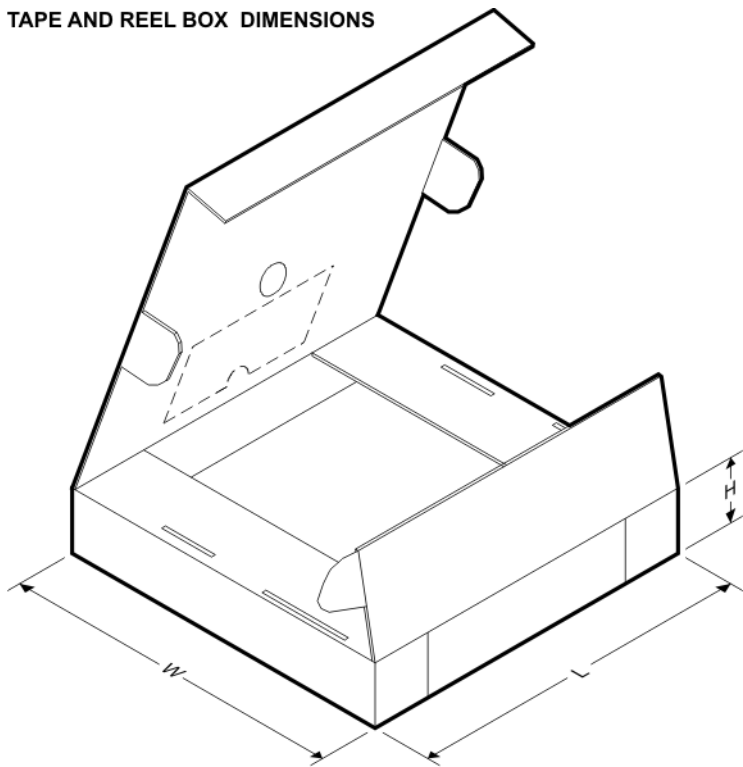

*All dimensions are nominal

Device	Package Type	Package Drawing	Pins	SPQ	Length (mm)	Width (mm)	Height (mm)
INA2132U/2K5	SOIC	D	14	2500	367.0	367.0	38.0
INA2132UA/2K5	SOIC	D	14	2500	367.0	367.0	38.0

D (R-PDSO-G14)

PLASTIC SMALL OUTLINE



4040047-5/M 06/11

- NOTES:
- A. All linear dimensions are in inches (millimeters).
 - B. This drawing is subject to change without notice.
 - $\triangle C$ Body length does not include mold flash, protrusions, or gate burrs. Mold flash, protrusions, or gate burrs shall not exceed 0.006 (0,15) each side.
 - $\triangle D$ Body width does not include interlead flash. Interlead flash shall not exceed 0.017 (0,43) each side.
 - E. Reference JEDEC MS-012 variation AB.

D (R-PDSO-G14)

PLASTIC SMALL OUTLINE



- NOTES:
- A. All linear dimensions are in millimeters.
 - B. This drawing is subject to change without notice.
 - C. Publication IPC-7351 is recommended for alternate designs.
 - D. Laser cutting apertures with trapezoidal walls and also rounding corners will offer better paste release. Customers should contact their board assembly site for stencil design recommendations. Refer to IPC-7525 for other stencil recommendations.
 - E. Customers should contact their board fabrication site for solder mask tolerances between and around signal pads.

IMPORTANT NOTICE

Texas Instruments Incorporated (TI) reserves the right to make corrections, enhancements, improvements and other changes to its semiconductor products and services per JESD46, latest issue, and to discontinue any product or service per JESD48, latest issue. Buyers should obtain the latest relevant information before placing orders and should verify that such information is current and complete.

TI's published terms of sale for semiconductor products (<http://www.ti.com/sc/docs/stdterms.htm>) apply to the sale of packaged integrated circuit products that TI has qualified and released to market. Additional terms may apply to the use or sale of other types of TI products and services.

Reproduction of significant portions of TI information in TI data sheets is permissible only if reproduction is without alteration and is accompanied by all associated warranties, conditions, limitations, and notices. TI is not responsible or liable for such reproduced documentation. Information of third parties may be subject to additional restrictions. Resale of TI products or services with statements different from or beyond the parameters stated by TI for that product or service voids all express and any implied warranties for the associated TI product or service and is an unfair and deceptive business practice. TI is not responsible or liable for any such statements.

Buyers and others who are developing systems that incorporate TI products (collectively, "Designers") understand and agree that Designers remain responsible for using their independent analysis, evaluation and judgment in designing their applications and that Designers have full and exclusive responsibility to assure the safety of Designers' applications and compliance of their applications (and of all TI products used in or for Designers' applications) with all applicable regulations, laws and other applicable requirements. Designer represents that, with respect to their applications, Designer has all the necessary expertise to create and implement safeguards that (1) anticipate dangerous consequences of failures, (2) monitor failures and their consequences, and (3) lessen the likelihood of failures that might cause harm and take appropriate actions. Designer agrees that prior to using or distributing any applications that include TI products, Designer will thoroughly test such applications and the functionality of such TI products as used in such applications.

TI's provision of technical, application or other design advice, quality characterization, reliability data or other services or information, including, but not limited to, reference designs and materials relating to evaluation modules, (collectively, "TI Resources") are intended to assist designers who are developing applications that incorporate TI products; by downloading, accessing or using TI Resources in any way, Designer (individually or, if Designer is acting on behalf of a company, Designer's company) agrees to use any particular TI Resource solely for this purpose and subject to the terms of this Notice.

TI's provision of TI Resources does not expand or otherwise alter TI's applicable published warranties or warranty disclaimers for TI products, and no additional obligations or liabilities arise from TI providing such TI Resources. TI reserves the right to make corrections, enhancements, improvements and other changes to its TI Resources. TI has not conducted any testing other than that specifically described in the published documentation for a particular TI Resource.

Designer is authorized to use, copy and modify any individual TI Resource only in connection with the development of applications that include the TI product(s) identified in such TI Resource. NO OTHER LICENSE, EXPRESS OR IMPLIED, BY ESTOPPEL OR OTHERWISE TO ANY OTHER TI INTELLECTUAL PROPERTY RIGHT, AND NO LICENSE TO ANY TECHNOLOGY OR INTELLECTUAL PROPERTY RIGHT OF TI OR ANY THIRD PARTY IS GRANTED HEREIN, including but not limited to any patent right, copyright, mask work right, or other intellectual property right relating to any combination, machine, or process in which TI products or services are used. Information regarding or referencing third-party products or services does not constitute a license to use such products or services, or a warranty or endorsement thereof. Use of TI Resources may require a license from a third party under the patents or other intellectual property of the third party, or a license from TI under the patents or other intellectual property of TI.

TI RESOURCES ARE PROVIDED "AS IS" AND WITH ALL FAULTS. TI DISCLAIMS ALL OTHER WARRANTIES OR REPRESENTATIONS, EXPRESS OR IMPLIED, REGARDING RESOURCES OR USE THEREOF, INCLUDING BUT NOT LIMITED TO ACCURACY OR COMPLETENESS, TITLE, ANY EPIDEMIC FAILURE WARRANTY AND ANY IMPLIED WARRANTIES OF MERCHANTABILITY, FITNESS FOR A PARTICULAR PURPOSE, AND NON-INFRINGEMENT OF ANY THIRD PARTY INTELLECTUAL PROPERTY RIGHTS. TI SHALL NOT BE LIABLE FOR AND SHALL NOT DEFEND OR INDEMNIFY DESIGNER AGAINST ANY CLAIM, INCLUDING BUT NOT LIMITED TO ANY INFRINGEMENT CLAIM THAT RELATES TO OR IS BASED ON ANY COMBINATION OF PRODUCTS EVEN IF DESCRIBED IN TI RESOURCES OR OTHERWISE. IN NO EVENT SHALL TI BE LIABLE FOR ANY ACTUAL, DIRECT, SPECIAL, COLLATERAL, INDIRECT, PUNITIVE, INCIDENTAL, CONSEQUENTIAL OR EXEMPLARY DAMAGES IN CONNECTION WITH OR ARISING OUT OF TI RESOURCES OR USE THEREOF, AND REGARDLESS OF WHETHER TI HAS BEEN ADVISED OF THE POSSIBILITY OF SUCH DAMAGES.

Unless TI has explicitly designated an individual product as meeting the requirements of a particular industry standard (e.g., ISO/TS 16949 and ISO 26262), TI is not responsible for any failure to meet such industry standard requirements.

Where TI specifically promotes products as facilitating functional safety or as compliant with industry functional safety standards, such products are intended to help enable customers to design and create their own applications that meet applicable functional safety standards and requirements. Using products in an application does not by itself establish any safety features in the application. Designers must ensure compliance with safety-related requirements and standards applicable to their applications. Designer may not use any TI products in life-critical medical equipment unless authorized officers of the parties have executed a special contract specifically governing such use. Life-critical medical equipment is medical equipment where failure of such equipment would cause serious bodily injury or death (e.g., life support, pacemakers, defibrillators, heart pumps, neurostimulators, and implantables). Such equipment includes, without limitation, all medical devices identified by the U.S. Food and Drug Administration as Class III devices and equivalent classifications outside the U.S.

TI may expressly designate certain products as completing a particular qualification (e.g., Q100, Military Grade, or Enhanced Product). Designers agree that it has the necessary expertise to select the product with the appropriate qualification designation for their applications and that proper product selection is at Designers' own risk. Designers are solely responsible for compliance with all legal and regulatory requirements in connection with such selection.

Designer will fully indemnify TI and its representatives against any damages, costs, losses, and/or liabilities arising out of Designer's non-compliance with the terms and provisions of this Notice.

Looking for pricing, stock, or lifecycle information?

Click below to explore more details on WIN SOURCE:

 [View INA2132UA](#) on WIN SOURCE

 [Texas Instruments](#) Information

Optimize Your Supply Chain with WIN SOURCE Solutions

-  Global Sourcing Solution
-  Obsolete Management
-  Cost Control Management
-  Shortage Management
-  Alternative Solution
-  Excess Inventory Management