



**THE DATASHEET OF
INA196AQDBVRQ1**



INA19xA-Q1 Current Shunt Monitors –16-V to 80-V Common-Mode Range

1 Features

- Qualified for Automotive Applications
- Wide Common-Mode Voltage: –16 V to 80 V
- Low Error: 3% Overtemperature (Maximum)
- Bandwidth: Up to 500 kHz
- Three Transfer Functions Available: 20 V/V, 50 V/V, and 100 V/V
- Complete Current-Sense Solution

2 Applications

- Welding Equipment
- Body Control Modules
- Load Health Monitoring
- Telecom Equipment
- HEV/EV Powertrain
- Power Management
- Battery Chargers

3 Description

The INA19xA-Q1 family of current shunt monitors with voltage output can sense drops across shunts at common-mode voltages from –16 V to 80 V, independent of the INA19xA supply voltage. They are available with three output voltage scales: 20 V/V, 50 V/V, and 100 V/V. The 500-kHz bandwidth simplifies use in current control loops and monitoring DC motor health. The INA193A–INA195A provide identical functions but alternative pin configurations to the INA196A–INA198A, respectively.

The INA19xA-Q1 operate from a single 2.7-V to 18-V supply. They are specified over the extended operating temperature range (–40°C to 125°C), and are offered in a space-saving SOT-23 package.

Device Information⁽¹⁾

PART NUMBER	PACKAGE	BODY SIZE (NOM)
INA19xA-Q1	SOT-23 (5)	2.90 mm × 1.60 mm

(1) For all available packages, see the package option addendum at the end of the data sheet.

Simplified Schematic

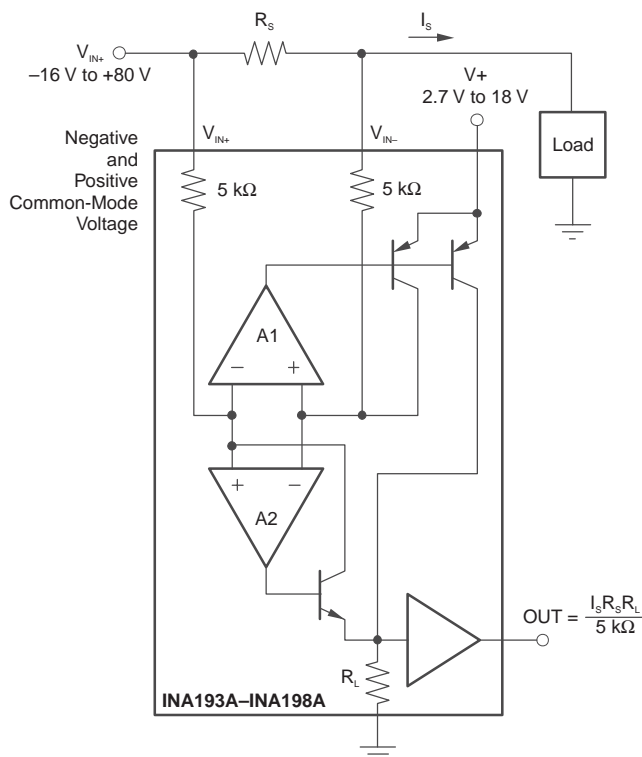

Table of Contents

1 Features	1	7.4 Device Functional Modes.....	16
2 Applications	1	8 Application and Implementation	20
3 Description	1	8.1 Application Information.....	20
4 Revision History	2	8.2 Typical Application	20
5 Pin Configuration and Functions	3	9 Power Supply Recommendations	21
6 Specifications	4	10 Layout	22
6.1 Absolute Maximum Ratings	4	10.1 Layout Guidelines	22
6.2 ESD Ratings.....	4	10.2 Layout Example	22
6.3 Recommended Operating Conditions.....	4	11 Device and Documentation Support	23
6.4 Thermal Information	4	11.1 Related Links	23
6.5 Electrical Characteristics.....	5	11.2 Receiving Notification of Documentation Updates	23
6.6 Typical Characteristics	7	11.3 Community Resources.....	23
7 Detailed Description	11	11.4 Trademarks	23
7.1 Overview	11	11.5 Electrostatic Discharge Caution.....	23
7.2 Functional Block Diagram	11	11.6 Glossary	23
7.3 Feature Description.....	11	12 Mechanical, Packaging, and Orderable Information	23

4 Revision History

NOTE: Page numbers for previous revisions may differ from page numbers in the current version.

Changes from Revision C (October 2008) to Revision D

Page

- Added *ESD Ratings* table, *Feature Description* section, *Device Functional Modes*, *Application and Implementation* section, *Power Supply Recommendations* section, *Layout* section, *Device and Documentation Support* section, and *Mechanical, Packaging, and Orderable Information* section
- Added Input Bias Current vs Common Mode Voltage $V_s=5$ V graph to *Typical Characteristics*
- Added Input Bias Current vs Common Mode Voltage $V_s=12$ V graph to *Typical Characteristics*.....

5 Pin Configuration and Functions

**DBV Package
5-Pin SOT-23
INA193A-Q1, INA194A-Q1, INA195A-Q1 Top View**

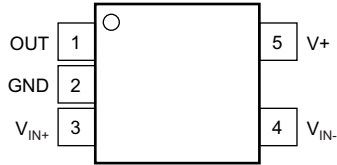

**DBV Package
5-Pin SOT-23
INA196A-Q1, INA197A-Q1, INA198A-Q1 Top View**

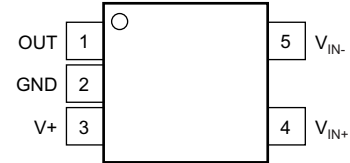

Pin Functions

NAME	PIN		TYPE	DESCRIPTION
	INA193A-Q1, INA194A-Q1, INA195A-Q1	INA196A-Q1, INA197A-Q1, INA198A-Q1		
GND	2	2	GND	Ground
OUT	1	1	O	Output voltage
V+	5	3	Analog	Power supply, 2.7 to 18 V
V _{IN+}	3	4	I	Connect to supply side of shunt resistor
V _{IN-}	4	5	I	Connect to load side of shunt resistor

6 Specifications

6.1 Absolute Maximum Ratings

over operating free-air temperature range (unless otherwise noted)⁽¹⁾

	MIN	MAX	UNIT
Supply voltage		18	V
Differential input voltage range, analog inputs ($V_{IN+} - V_{IN-}$)	-18	18	V
Common-mode voltage range ⁽²⁾	-16	80	V
Analog output voltage range ⁽²⁾	OUT	GND - 0.3 (V+) + 0.3	V
Input current into any pin ⁽²⁾		5	mA
Junction temperature		150	°C
Storage temperature, T_{stg}	-65	150	°C

- (1) Stresses beyond those listed under *Absolute Maximum Ratings* may cause permanent damage to the device. These are stress ratings only, which do not imply functional operation of the device at these or any other conditions beyond those indicated under *Recommended Operating Conditions*. Exposure to absolute-maximum-rated conditions for extended periods may affect device reliability.
- (2) Input voltage at any pin may exceed the voltage shown if the current at that pin is limited to 5 mA.

6.2 ESD Ratings

	VALUE	UNIT
$V_{(ESD)}$ Electrostatic discharge	Human-body model (HBM), per AEC Q100-002 ⁽¹⁾	±4000
	Charged-device model (CDM), per AEC Q100-011	±1000
	Machine model	±200

- (1) AEC Q100-002 indicates that HBM stressing shall be in accordance with the ANSI/ESDA/JEDEC JS-001 specification.

6.3 Recommended Operating Conditions

over operating free-air temperature range (unless otherwise noted)

	MIN	NOM	MAX	UNIT
V_{CM} Common-mode input voltage		12		V
$V+$ Operating supply voltage		12		V
T_A Operating free-air temperature	-40		125	°C

6.4 Thermal Information

THERMAL METRIC ⁽¹⁾	INA19xA-Q1	UNIT
	DBV (SOT-23)	
	5 PINS	
$R_{\theta JA}$ Junction-to-ambient thermal resistance	221.7	°C/W
$R_{\theta JC(top)}$ Junction-to-case (top) thermal resistance	144.7	°C/W
$R_{\theta JB}$ Junction-to-board thermal resistance	49.7	°C/W
Ψ_{JT} Junction-to-top characterization parameter	26.1	°C/W
Ψ_{JB} Junction-to-board characterization parameter	49	°C/W

- (1) For more information about traditional and new thermal metrics, see the *Semiconductor and IC Package Thermal Metrics* application report, [SPRA953](#).

6.5 Electrical Characteristics

 $V_S = 12\text{ V}$, $V_{IN+} = 12\text{ V}$, $V_{SENSE} = 100\text{ mV}$ (unless otherwise noted) Full range $T_A = -40^\circ\text{C}$ to 125°C

PARAMETER		TEST CONDITIONS	T_A	MIN	TYP	MAX	UNIT
INPUT							
V_{SENSE}	Full-scale input voltage	$V_{SENSE} = V_{IN+} - V_{IN-}$	25°C		0.15	$(V_S - 0.2)/\text{Gain}$	V
VCM	Common-mode input		Full range	-16		80	V
CMR	Common-mode rejection	$V_{IN+} = -16\text{ V to }80\text{ V}$	25°C	80	94		dB
		$V_{IN+} = 12\text{ V to }80\text{ V}$	Full range	100	120		
V_{OS}	Offset voltage, RTI		25°C		± 0.5	2	mV
			Full range		0.5	3	
dV_{OS}/dT	Offset voltage vs temperature		Full range		2.5		$\mu\text{V}/^\circ\text{C}$
PSR	Offset voltage vs power supply	$V_S = 2.7\text{ V to }18\text{ V}$, $V_{IN+} = 18\text{ V}$	Full range		5	100	$\mu\text{V}/\text{V}$
I_B	Input bias current	V_{IN-} pin	Full range		± 8	± 23	μA
OUTPUT ($V_{SENSE} \geq 20\text{ mV}$)							
G	Gain	INA193A, INA196A	25°C	20		V/V	
		INA194A, INA197A		50			
		INA195A, INA198A		100			
	Gain error	$V_{SENSE} = 20\text{ mV to }100\text{ mV}$	25°C	$\pm 0.2\%$	$\pm 1\%$		
			Full range		$\pm 2\%$		
	Total output error ⁽¹⁾		25°C	$\pm 0.75\%$	$\pm 2.2\%$		
			Full range	$\pm 1\%$	$\pm 3\%$		
	Nonlinearity error	$V_{SENSE} = 20\text{ mV to }100\text{ mV}$	25°C	$\pm 0.002\%$	$\pm 0.1\%$		
R_O	Output impedance		25°C	1.5		Ω	
	Maximum capacitive load	No sustained oscillation	25°C	10		nF	
OUTPUT ($V_{SENSE} < 20\text{ mV}$)⁽²⁾							
V_{OUT}	Output voltage	All devices	25°C	$-16\text{ V} \leq V_{CM} < 0$	300		mV
				$V_S < V_{CM} \leq 80\text{ V}$	300		
		INA193A, INA196A		$0\text{ V} \leq V_{CM} \leq V_S$, $V_S = 5\text{ V}$	0.4		V
		INA194A, INA197A			1		
INA195A, INA198A	2						
VOLTAGE OUTPUT⁽³⁾							
	Swing to V_+ power-supply rail	$R_L = 100\text{ k}\Omega$ to GND	Full range	$V_+ - 0.1$	$V_+ - 0.2$	V	
	Swing to GND ⁽⁴⁾	$R_L = 100\text{ k}\Omega$ to GND	Full range	$V_{GND} + 3$	$V_{GND} + 50$	mV	

(1) Total output error includes effects of gain error and V_{OS} .

(2) For details on this region of operation, see [Accuracy Variations as a Result Of \$V_{SENSE}\$ and Common Mode Voltage](#).

(3) See [Figure 7](#).

(4) Specified by design

Electrical Characteristics (continued)

$V_S = 12\text{ V}$, $V_{IN+} = 12\text{ V}$, $V_{SENSE} = 100\text{ mV}$ (unless otherwise noted) Full range $T_A = -40^\circ\text{C}$ to 125°C

PARAMETER		TEST CONDITIONS		T_A	MIN	TYP	MAX	UNIT
FREQUENCY RESPONSE								
BW	Bandwidth	INA193A, INA196A	$C_{LOAD} = 5\text{ pF}$	25°C	500		300	kHz
		INA194A, INA197A			300			
		INA195A, INA198A			200			
	Phase margin	$C_{LOAD} < 10\text{ nF}$		25°C	40		°	
SR	Slew rate				1		V/ μs	
t_s	Settling time (1%)	$V_{SENSE} = 10\text{ mV}$ to 100 mV_{PP} , $C_{LOAD} = 5\text{ pF}$		25°C	2		μs	
NOISE, RTI								
	Voltage noise density			25°C	40		nV/ $\sqrt{\text{Hz}}$	
POWER SUPPLY								
V_S	Operating voltage			Full range	2.7	18		V
I_Q	Quiescent current	$V_{OUT} = 2\text{ V}$		Full range	700		1250	μA
		INA193A, INA194A, INA196A, INA197A	$V_{SENSE} = 0\text{ mV}$	Full range	370		950	
		INA195A, INA198A			370		1050	
TEMPERATURE RANGE								
	Operating temperature				-40	125		°C
	Storage temperature				-65	150		°C

6.6 Typical Characteristics

$T_A = 25^\circ\text{C}$, $V_S = 12\text{ V}$, $V_{IN+} = 12\text{ V}$, and $V_{SENSE} = 100\text{ mV}$ (unless otherwise noted)

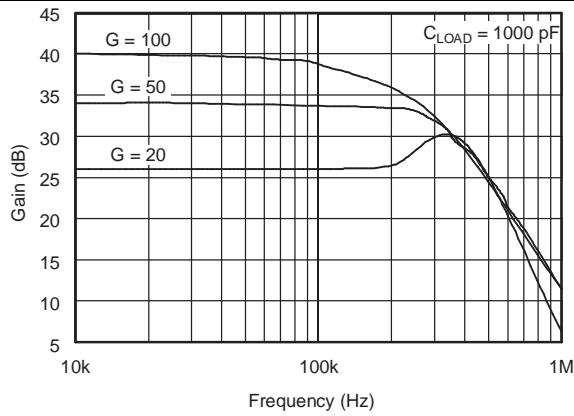

Figure 1. Gain vs Frequency

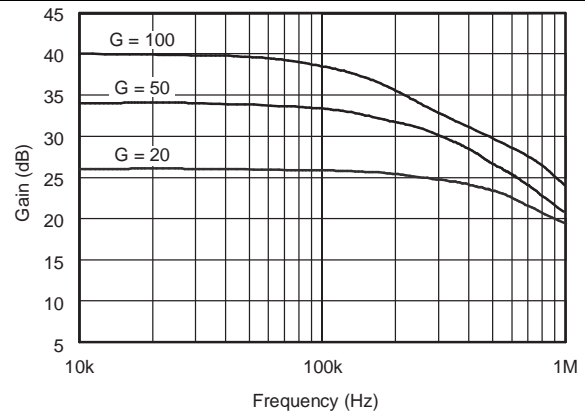

Figure 2. Gain vs Frequency

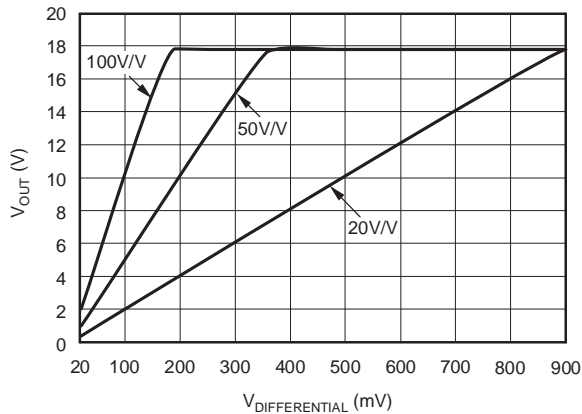

Figure 3. Gain Plot

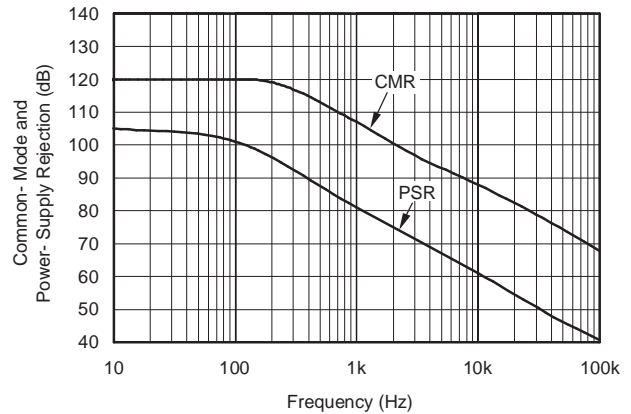

Figure 4. Common-Mode and Power-Supply Rejection vs Frequency

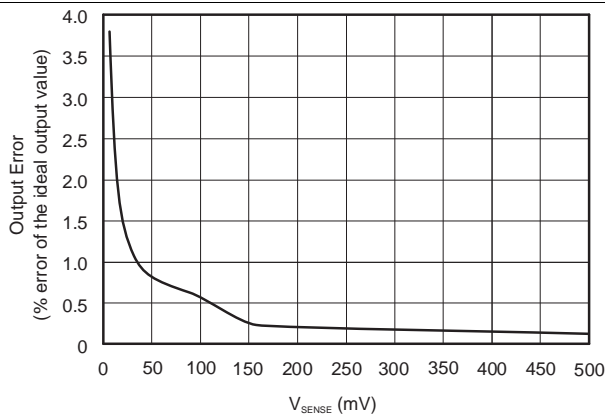

Figure 5. Output Error vs Vsense

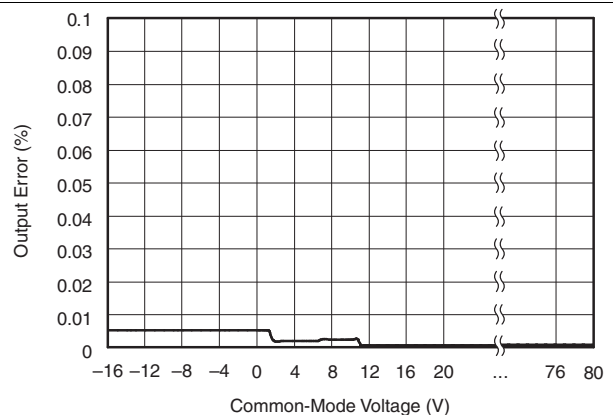

Figure 6. Output Error vs Common-Mode Voltage

Typical Characteristics (continued)

$T_A = 25^\circ\text{C}$, $V_S = 12\text{ V}$, $V_{IN+} = 12\text{ V}$, and $V_{SENSE} = 100\text{ mV}$ (unless otherwise noted)

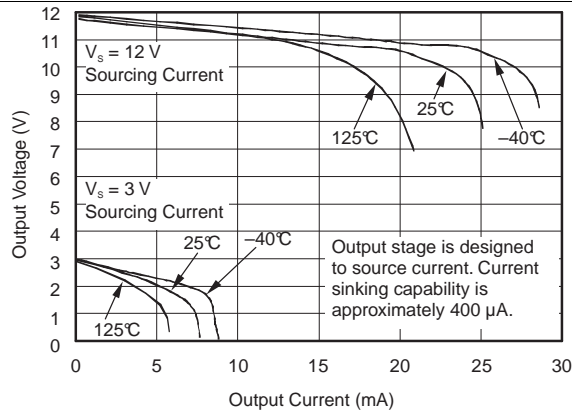

Figure 7. Positive Output Voltage Swing vs Output Current

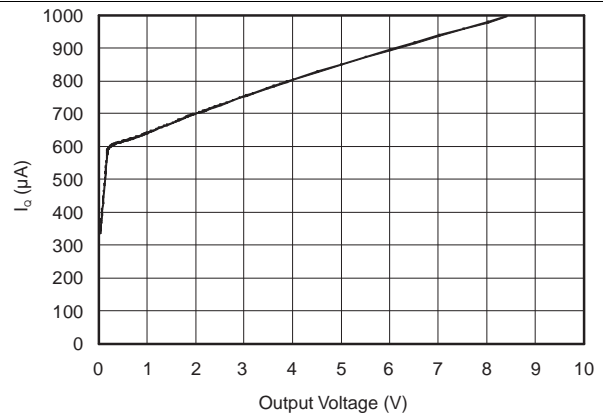

Figure 8. Quiescent Current vs Output Voltage

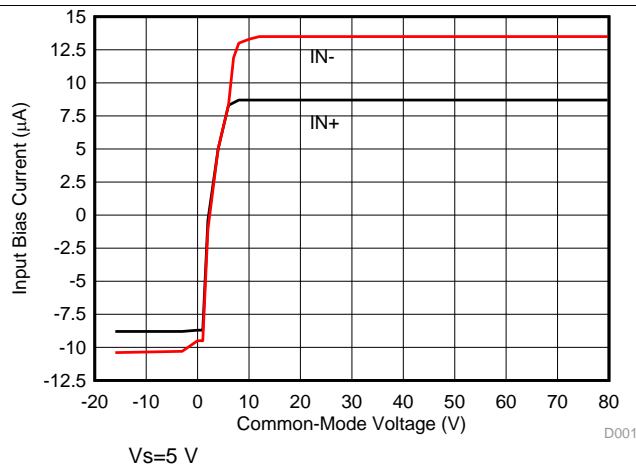

Figure 9. Input Bias Current vs Common Mode Voltage

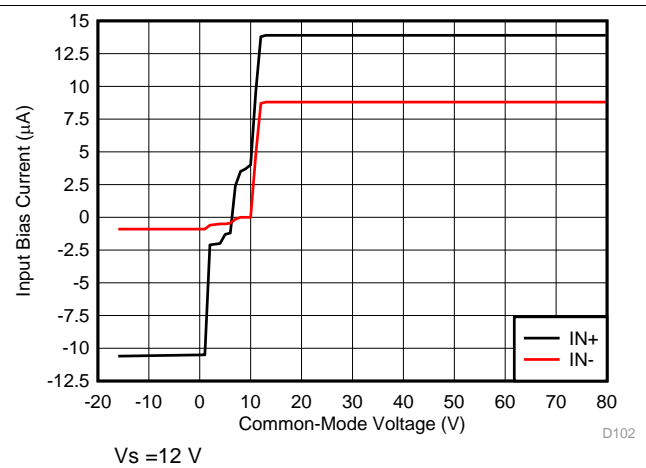

Figure 10. Input Bias Current vs Common Mode Voltage

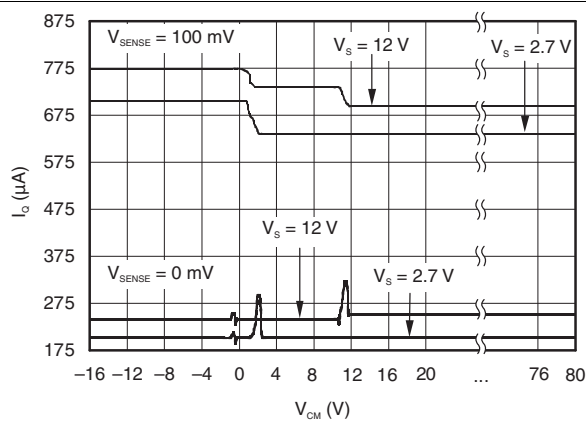

Figure 11. Quiescent Current vs Common Mode Voltage

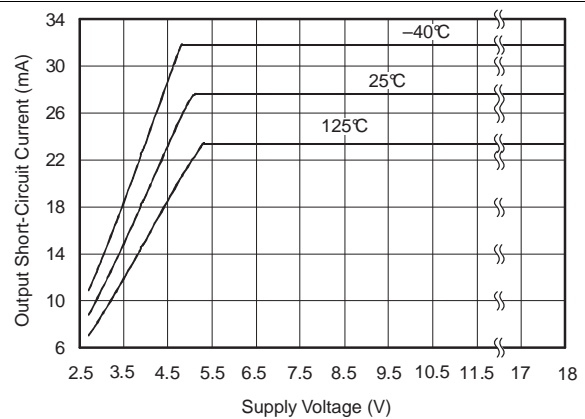
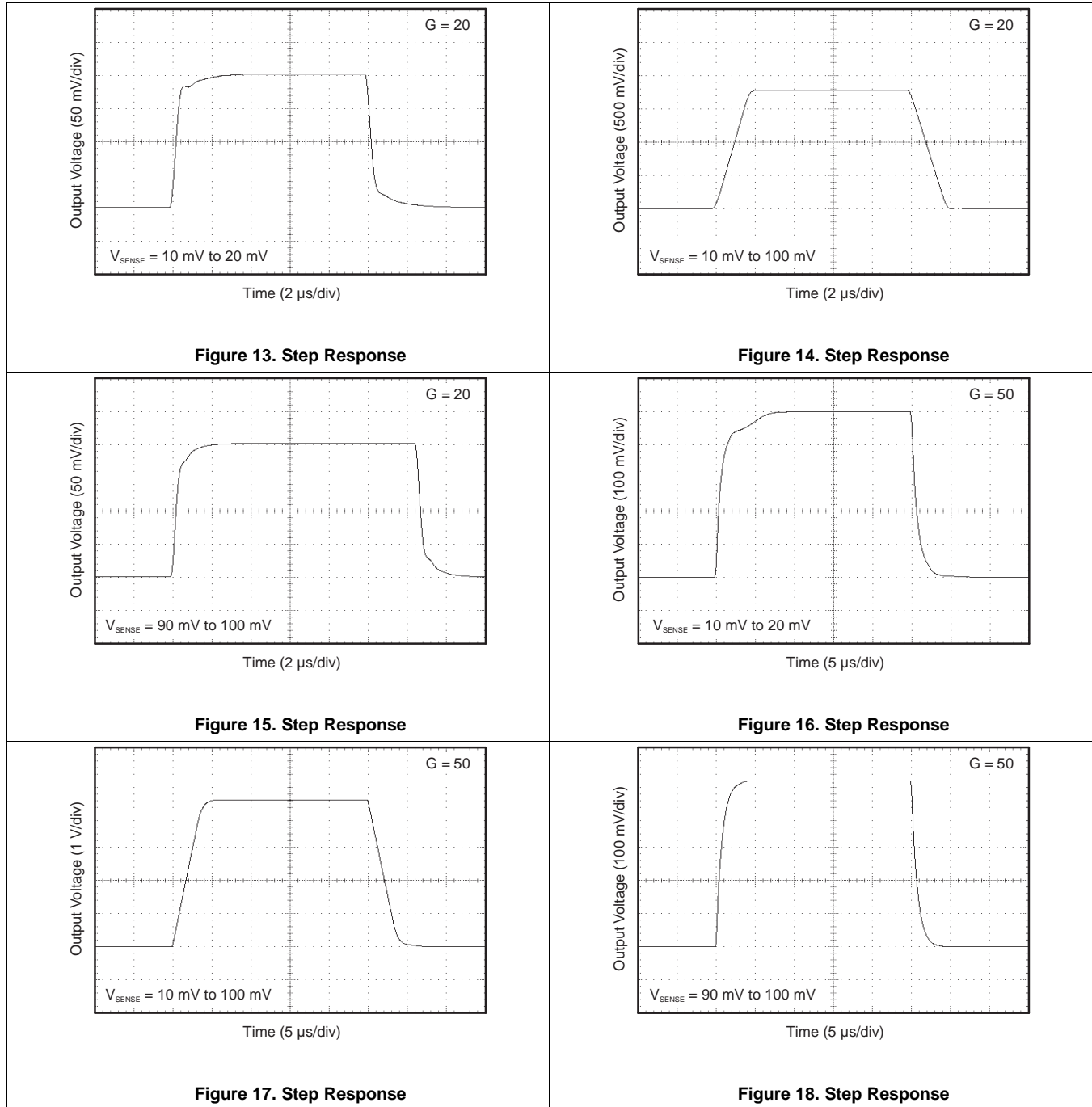

Figure 12. Output Short-Circuit Current vs Supply Voltage

Typical Characteristics (continued)

$T_A = 25^\circ\text{C}$, $V_S = 12\text{ V}$, $V_{IN+} = 12\text{ V}$, and $V_{SENSE} = 100\text{ mV}$ (unless otherwise noted)



Typical Characteristics (continued)

$T_A = 25^\circ\text{C}$, $V_S = 12\text{ V}$, $V_{IN+} = 12\text{ V}$, and $V_{SENSE} = 100\text{ mV}$ (unless otherwise noted)

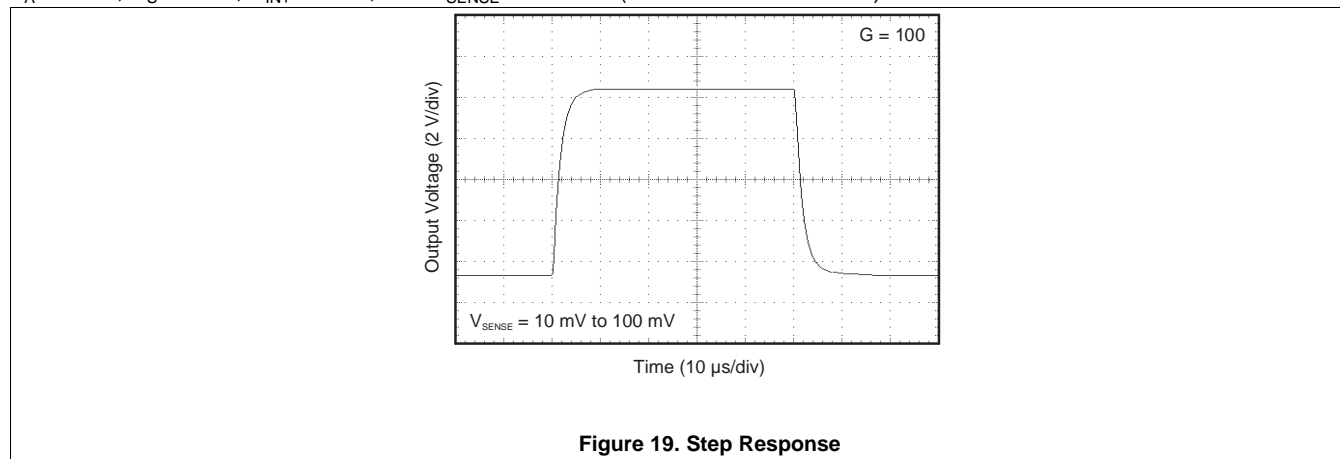

Figure 19. Step Response

7 Detailed Description

7.1 Overview

The INA193A–INA198A family of current shunt monitors with voltage output can sense drops across shunts at common mode voltages from -16 V to 80 V , independent of the INA19x supply voltage. They are available with three output voltage scales: 20 V/V , 50 V/V , and 100 V/V . The 500-kHz bandwidth simplifies use in current control loops. The INA193A–INA195A devices provide identical functions but alternative pin configurations to the INA196A–INA198A, respectively.

The INA193A–INA198A devices operate from a single 2.7-V to 18-V supply, drawing a maximum of $900\text{ }\mu\text{A}$ of supply current. They are specified over the extended operating temperature range (-40°C to 125°C), and are offered in a space-saving SOT-23 package.

7.2 Functional Block Diagram

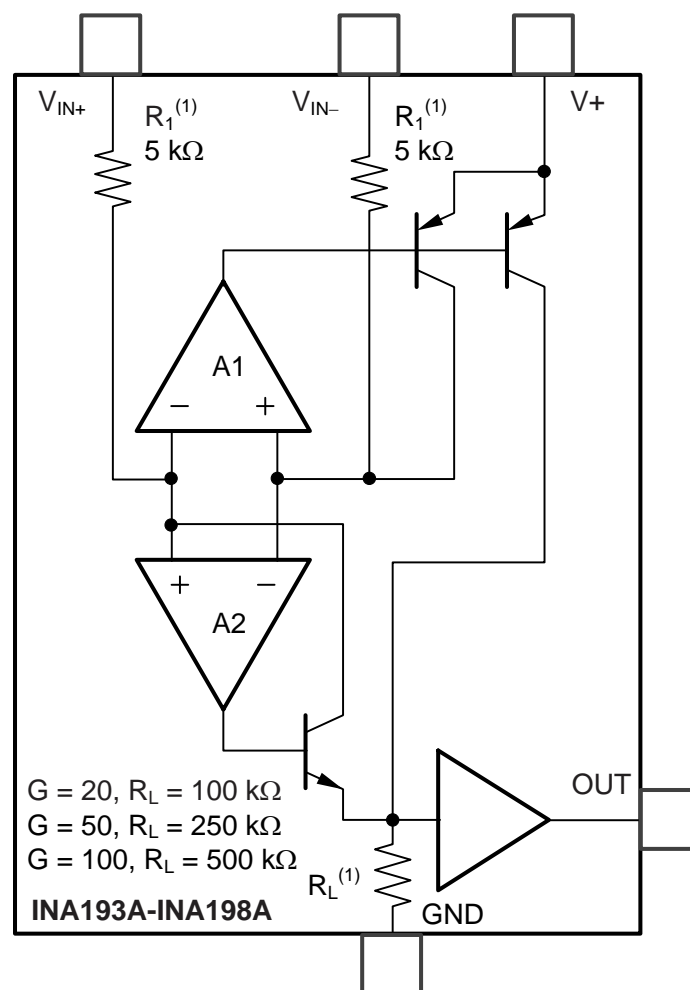

7.3 Feature Description

7.3.1 Basic Connection

Figure 20 shows the basic connection of the INA19xA. The input pins, V_{IN+} and V_{IN-} , should be connected as closely as possible to the shunt resistor to minimize any resistance in series with the shunt resistance.

Power-supply bypass capacitors are required for stability. Applications with noisy or high-impedance power supplies may require additional decoupling capacitors to reject power-supply noise. Connect bypass capacitors close to the device pins.

Feature Description (continued)

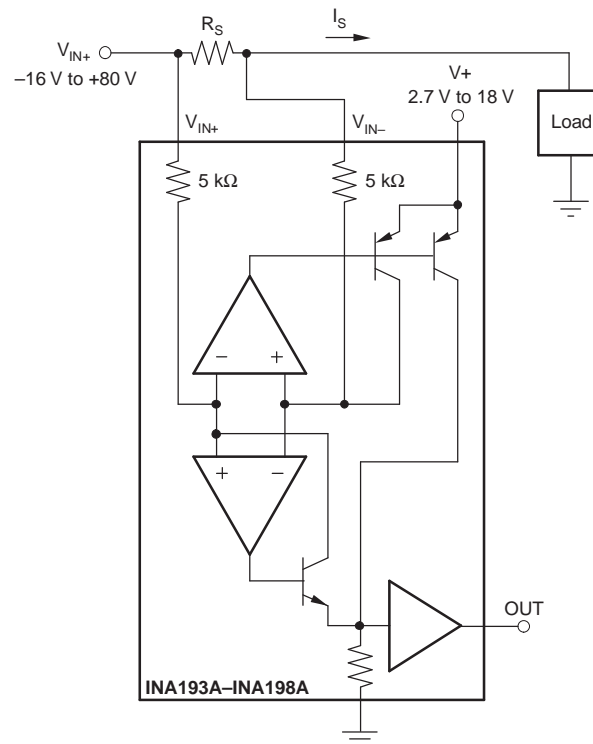

Figure 20. INA19xA Basic Connections

7.3.2 Selecting R_S

The value chosen for the shunt resistor, R_S , depends on the application and is a compromise between small-signal accuracy and maximum permissible voltage loss in the measurement line. High values of R_S provide better accuracy at lower currents by minimizing the effects of offset, while low values of R_S minimize voltage loss in the supply line. For most applications, best performance is attained with an R_S value that provides a full-scale shunt voltage range of 50 mV to 100 mV. Maximum input voltage for accurate measurements is 500 mV.

7.3.3 Inside the INA19xA

The INA19xA uses a new, unique, internal circuit topology that provides common mode range extending from -16 V to 80 V while operating from a single power supply. The common mode rejection in a classic instrumentation amplifier approach is limited by the requirement for accurate resistor matching. By converting the induced input voltage to a current, the INA19xA provides common mode rejection that is no longer a function of closely matched resistor values, providing the enhanced performance necessary for such a wide common mode range. A simplified diagram (see [Figure 20](#)) shows the basic circuit function. When the common mode voltage is positive, amplifier A2 is active.

The differential input voltage, $V_{IN+} - V_{IN-}$ applied across R_S , is converted to a current through a $5\text{-k}\Omega$ resistor. This current is converted back to a voltage through R_L , and then amplified by the output buffer amplifier. When the common mode voltage is negative, amplifier A1 is active. The differential input voltage, $V_{IN+} - V_{IN-}$ applied across R_S , is converted to a current through a $5\text{-k}\Omega$ resistor. This current is sourced from a precision current mirror whose output is directed into R_L , converting the signal back into a voltage and amplified by the output buffer amplifier. Patent-pending circuit architecture ensures smooth device operation, even during the transition period where both amplifiers A1 and A2 are active.

Feature Description (continued)

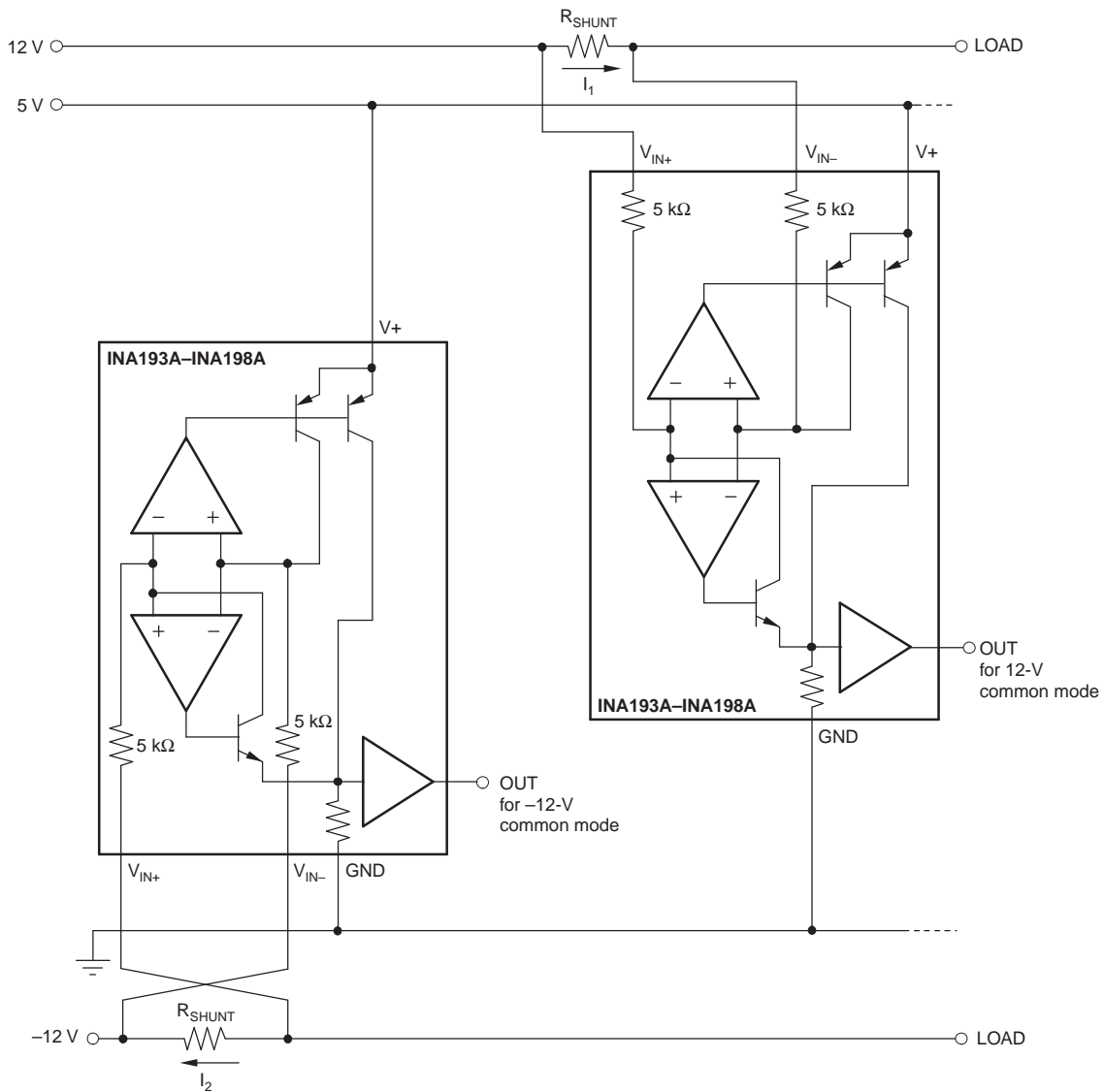

Figure 21. Monitor Bipolar Output Power-Supply Current

Feature Description (continued)

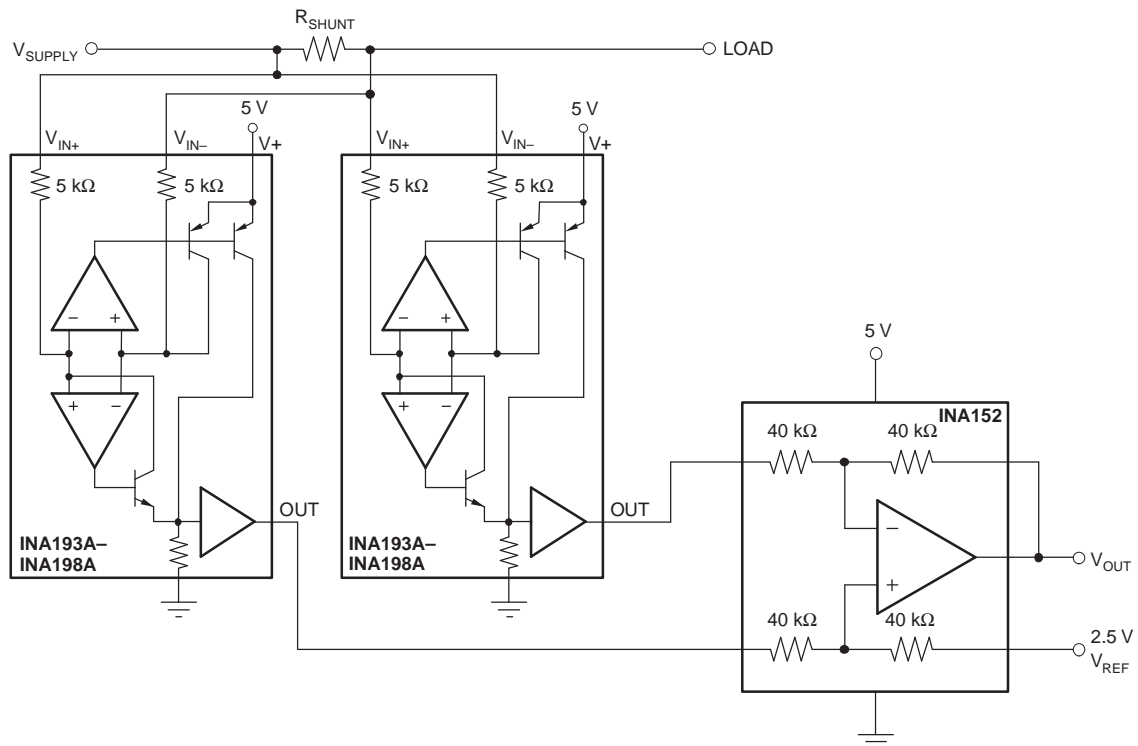

Figure 22. Bidirectional Current Monitoring

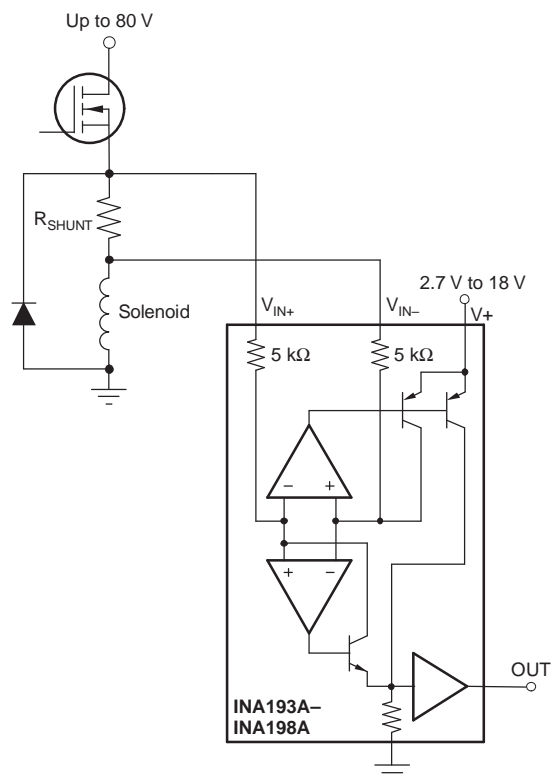
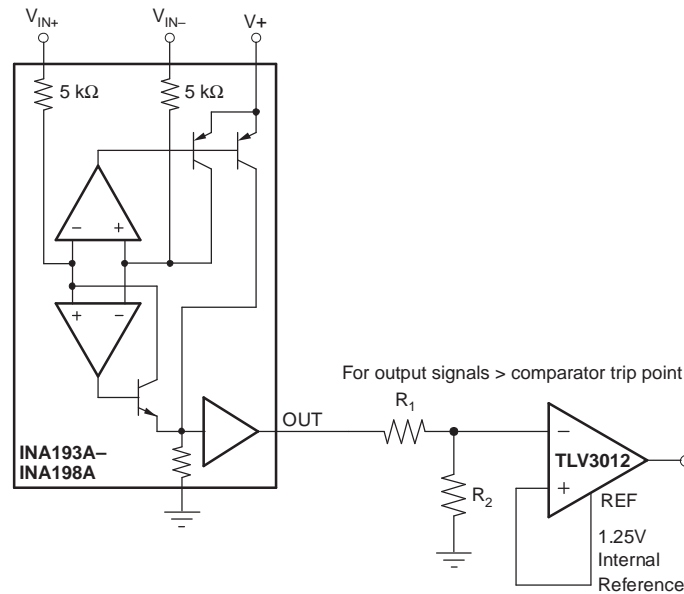
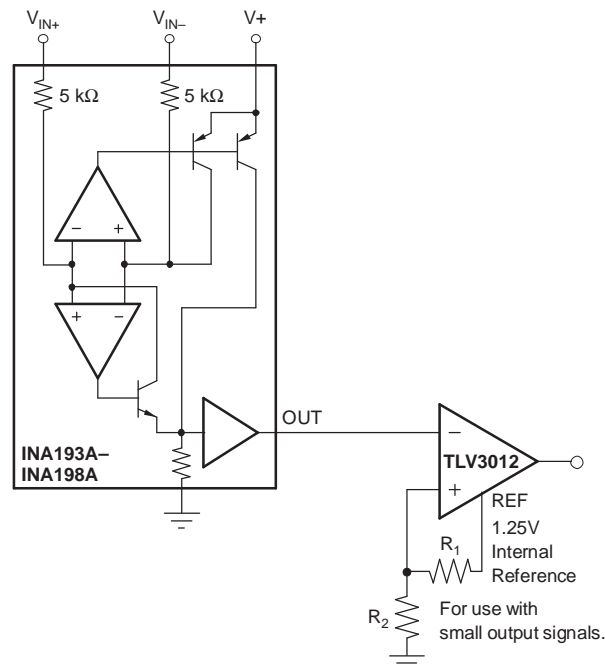

Figure 23. Inductive Current Monitor Including Flyback

Feature Description (continued)



(a) INA19xA Output Adjusted by Voltage Divider



(b) Comparator Reference Voltage Adjusted by Voltage Divider

Figure 24. INA19xA With Comparator

7.3.4 Power Supply

The input circuitry of the INA19xA can accurately measure beyond its power-supply voltage, V+. For example, the V+ power supply can be 5 V, whereas the load power-supply voltage is up to 80 V. The output voltage range of the OUT terminal, however, is limited by the voltages on the power-supply pin.

7.4 Device Functional Modes

7.4.1 Input Filtering

An obvious and straightforward location for filtering is at the output of the INA19xA series; however, this location negates the advantage of the low output impedance of the internal buffer. The only other option for filtering is at the input pins of the INA19xA, which is complicated by the internal 5-k Ω \pm 30% input impedance (see Figure 25). Using the lowest possible resistor values minimizes both the initial shift in gain and effects of tolerance. The effect on initial gain is given by:

$$\text{Gain Error \%} = 100 - \left(100 \times \frac{5 \text{ k}\Omega}{5 \text{ k}\Omega + R_{\text{FILT}}} \right) \quad (1)$$

Total effect on gain error can be calculated by replacing the 5-k Ω term with 5 k Ω – 30% (or 3.5 k Ω) or 5 k Ω + 30% (or 6.5 k Ω). The tolerance extremes of R_{FILT} can also be inserted into the equation. If a pair of 100- Ω 1% resistors are used on the inputs, the initial gain error is 1.96%. Worst-case tolerance conditions always occur at the lower excursion of the internal 5-k Ω resistor (3.5 k Ω), and the higher excursion of R_{FILT} , 3% in this case.

The specified accuracy of the INA19xA must then be combined in addition to these tolerances. While this discussion treats accuracy worst-case conditions by combining the extremes of the resistor values, it is appropriate to use geometric mean or root sum square calculations to total the effects of accuracy variations.

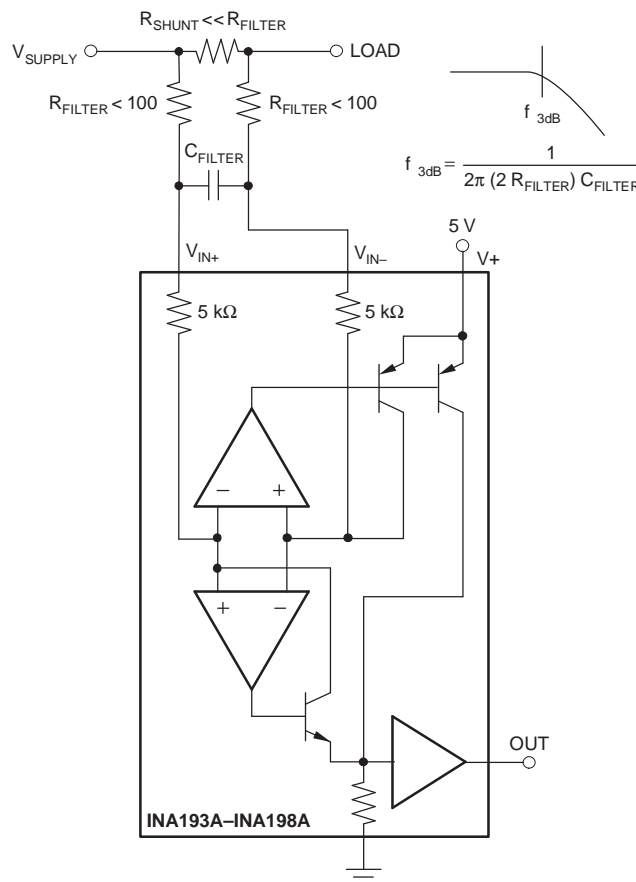

Figure 25. Input Filter (Gain Error = 1.5% to –2.2%)

7.4.2 Accuracy Variations as a Result Of V_{SENSE} and Common Mode Voltage

The accuracy of the INA19xA-Q1 current shunt monitors is a function of two main variables: V_{SENSE} ($V_{\text{IN+}} - V_{\text{IN-}}$) and common mode voltage, V_{CM} , relative to the supply voltage, V_{S} . V_{CM} is expressed as $(V_{\text{IN+}} + V_{\text{IN-}})/2$; however, in practice, V_{CM} is seen as the voltage at $V_{\text{IN+}}$ because the voltage drop across V_{SENSE} is usually small.

Device Functional Modes (continued)

This section addresses the accuracy of these specific operating regions:

- Normal Case 1: $V_{\text{SENSE}} \geq 20 \text{ mV}$, $V_{\text{CM}} \geq V_{\text{S}}$
- Normal Case 2: $V_{\text{SENSE}} \geq 20 \text{ mV}$, $V_{\text{CM}} < V_{\text{S}}$
- Low V_{SENSE} Case 1: $V_{\text{SENSE}} < 20 \text{ mV}$, $-16 \text{ V} \leq V_{\text{CM}} < 0$
- Low V_{SENSE} Case 2: $V_{\text{SENSE}} < 20 \text{ mV}$, $0 \text{ V} \leq V_{\text{CM}} \leq V_{\text{S}}$
- Low V_{SENSE} Case 3: $V_{\text{SENSE}} < 20 \text{ mV}$, $V_{\text{S}} < V_{\text{CM}} \leq 80 \text{ V}$

7.4.2.1 Normal Case 1: $V_{\text{SENSE}} \geq 20 \text{ mV}$, $V_{\text{CM}} \geq V_{\text{S}}$

This region of operation provides the highest accuracy. Here, the input offset voltage is characterized and measured using a two-step method. First, the gain is determined by (Equation 2).

$$G = \frac{V_{\text{OUT1}} - V_{\text{OUT2}}}{100 \text{ mV} - 20 \text{ mV}}$$

where

- V_{OUT1} = Output voltage with $V_{\text{SENSE}} = 100 \text{ mV}$
 - V_{OUT2} = Output voltage with $V_{\text{SENSE}} = 20 \text{ mV}$
- (2)

The offset voltage is then measured at $V_{\text{SENSE}} = 100 \text{ mV}$ and referred to the input (RTI) of the current shunt monitor, as shown in (Equation 3).

$$V_{\text{OSRTI}} (\text{Referred-To-Input}) = \left(\frac{V_{\text{OUT1}}}{G} \right) - 100 \text{ mV}$$
(3)

In the *Typical Characteristics*, the *Output Error vs Common Mode Voltage* curve shows the highest accuracy for this region of operation. In this plot, $V_{\text{S}} = 12 \text{ V}$; for $V_{\text{CM}} \geq 12 \text{ V}$, the output error is at its minimum. This case is also used to create the $V_{\text{SENSE}} \geq 20 \text{ mV}$ output specifications in the *Electrical Characteristics* table.

7.4.2.2 Normal Case 2: $V_{\text{SENSE}} \geq 20 \text{ mV}$, $V_{\text{CM}} < V_{\text{S}}$

This region of operation has slightly less accuracy than Normal Case 1 as a result of the common mode operating area in which the part functions, as seen in Figure 6. As noted, for this graph $V_{\text{S}} = 12 \text{ V}$; for $V_{\text{CM}} < 12 \text{ V}$, the Output Error increases as V_{CM} becomes less than 12 V , with a typical maximum error of 0.005% at the most negative $V_{\text{CM}} = -16 \text{ V}$.

7.4.2.3 Low V_{SENSE} Case 1: $V_{\text{SENSE}} < 20 \text{ mV}$, $-16 \text{ V} \leq V_{\text{CM}} < 0$; and Low V_{SENSE} Case 3: $V_{\text{SENSE}} < 20 \text{ mV}$, $V_{\text{S}} < V_{\text{CM}} \leq 80 \text{ V}$

Although the INA19xA-Q1 family of devices are not designed for accurate operation in either of these regions, some applications are exposed to these conditions; for example, when monitoring power supplies that are switched on and off while V_{S} is still applied to the INA19xA-Q1. It is important to know what the behavior of the devices will be in these regions.

As V_{SENSE} approaches 0 mV , in these V_{CM} regions, the device output accuracy degrades. A larger-than-normal offset can appear at the current shunt monitor output with a typical maximum value of $V_{\text{OUT}} = 300 \text{ mV}$ for $V_{\text{SENSE}} = 0 \text{ mV}$. As V_{SENSE} approaches 20 mV , V_{OUT} returns to the expected output value with accuracy as specified in *Electrical Characteristics*. Figure 26 illustrates this effect using the INA195A and INA198A (Gain = 100).

Device Functional Modes (continued)

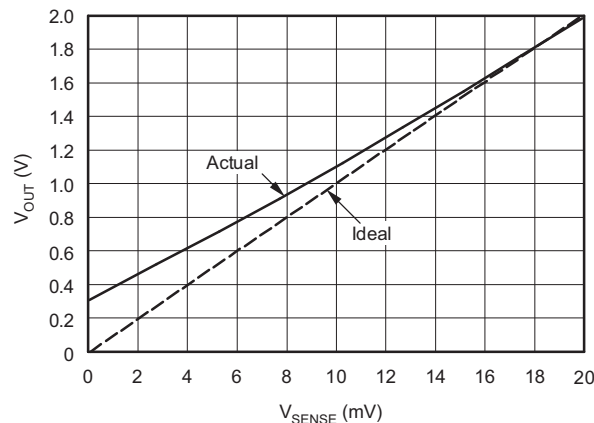
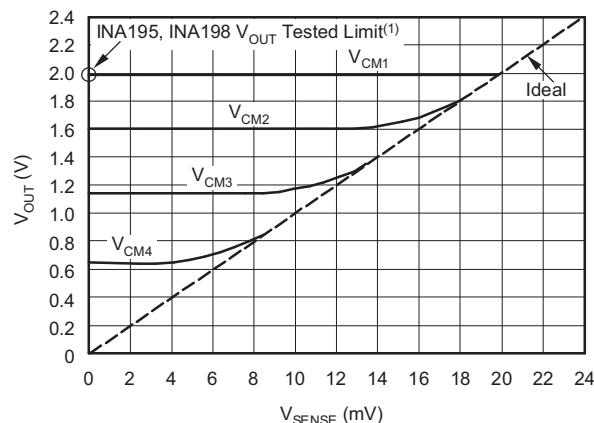

Figure 26. Example for Low V_{SENSE} Cases 1 and 3 (INA195A-Q1, INA198A-Q1: Gain = 100)

7.4.2.4 Low V_{SENSE} Case 2: $V_{SENSE} < 20$ mV, 0 V $\leq V_{CM} \leq V_S$

This region of operation is the least accurate for the INA19xA-Q1 family. To achieve the wide input common mode voltage range, these devices use two operational amplifier front ends in parallel. One operational amplifier front end operates in the positive input common mode voltage range, and the other in the negative input region. For this case, neither of these two internal amplifiers dominates and overall loop gain is very low. Within this region, V_{OUT} approaches voltages close to linear operation levels for Normal Case 2. This deviation from linear operation becomes greatest the closer V_{SENSE} approaches 0 V. Within this region, as V_{SENSE} approaches 20 mV, device operation is closer to that described by Normal Case 2. Figure 27 illustrates this behavior for the INA195A. The V_{OUT} maximum peak for this case is tested by maintaining a constant V_S , setting $V_{SENSE} = 0$ mV and sweeping V_{CM} from 0 V to V_S . The exact V_{CM} at which V_{OUT} peaks during this test varies from part to part, but the V_{OUT} maximum peak is tested to be less than the specified V_{OUT} tested limit.



- (1) INA193, INA196 V_{OUT} Tested Limit = 0.4 V
 INA194, INA197 V_{OUT} Tested Limit = 1 V

NOTE: V_{OUT} tested limit at $V_{SENSE} = 0$ mV, $0 \leq V_{CM1} \leq V_S$.

V_{CM2} , V_{CM3} , and V_{CM4} illustrate the variance from part to part of the V_{CM} that can cause maximum V_{OUT} with $V_{SENSE} < 20$ mV.

Figure 27. Example for Low V_{SENSE} Case 2 (INA195A, INA198A: Gain = 100)

Device Functional Modes (continued)

7.4.3 Shutdown

Because the INA19xA-Q1 consume a quiescent current less than 1 mA, they can be powered by either the output of logic gates or by transistor switches to supply power. Use a totem pole output buffer or gate that can provide sufficient drive along with 0.1 μF bypass capacitor, preferably ceramic with good high frequency characteristics. This gate should have a supply voltage of 3 V or greater because the INA19xA-Q1 requires a minimum supply greater than 2.7 V. In addition to eliminating quiescent current, this gate also turns off the 10 μA bias current present at each of the inputs. An example shutdown circuit is shown in Figure 28.

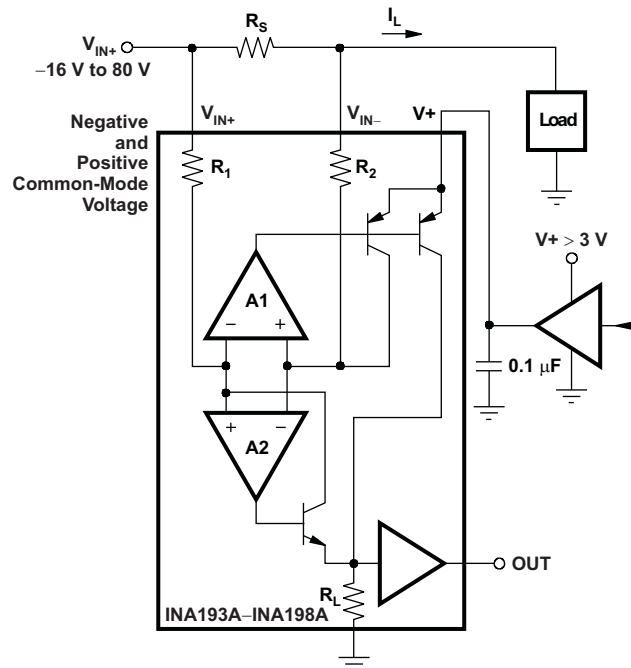

Figure 28. INA19xA-Q1 Example Shutdown Circuit

7.4.4 Transient Protection

The -16-V to 80-V common mode range of the INA19xA is ideal for withstanding automotive fault conditions ranging from 12-V battery reversal up to 80-V transients, because no additional protective components are needed up to those levels. In the event that the INA19xA is exposed to transients on the inputs in excess of its ratings, then external transient absorption with semiconductor transient absorbers (zeners or Transzorbs) are necessary. TI does not recommend using MOVs or VDRs except when they are used in addition to a semiconductor transient absorber. Select the transient absorber such that it never allows the INA19xA to be exposed to transients greater than 80 V (that is, allow for transient absorber tolerance, as well as additional voltage due to transient absorber dynamic impedance). Despite the use of internal zener-type ESD protection, the INA19xA does not lend itself to using external resistors in series with the inputs because the internal gain resistors can vary up to $\pm 30\%$. (If gain accuracy is not important, then resistors can be added in series with the INA19xA inputs with two equal resistors on each input.)

7.4.5 Output Voltage Range

The output of the INA19xA is accurate within the output voltage swing range set by the power supply pin, V+. This is best illustrated when using the INA195A or INA198A (which are both versions using a gain of 100), where a 100-mV full-scale input from the shunt resistor requires an output voltage swing of 10 V, and a power-supply voltage sufficient to achieve 10 V on the output.

8 Application and Implementation

NOTE

Information in the following applications sections is not part of the TI component specification, and TI does not warrant its accuracy or completeness. TI's customers are responsible for determining suitability of components for their purposes. Customers should validate and test their design implementation to confirm system functionality.

8.1 Application Information

The INA193A-INA198A devices measure the voltage developed across a current-sensing resistor when current passes through it. The ability to have shunt common mode voltages from -16V to 80V drive and control the output signal with V_S offers multiple configurations, as discussed throughout this section.

8.2 Typical Application

The device is a unidirectional, current-sense amplifier capable of measuring currents through a resistive shunt with shunt common mode voltages from -16V to 80V . Two devices can be configured for bidirectional monitoring and is common in applications that include charging and discharging operations where the current flow-through resistor can change directions.

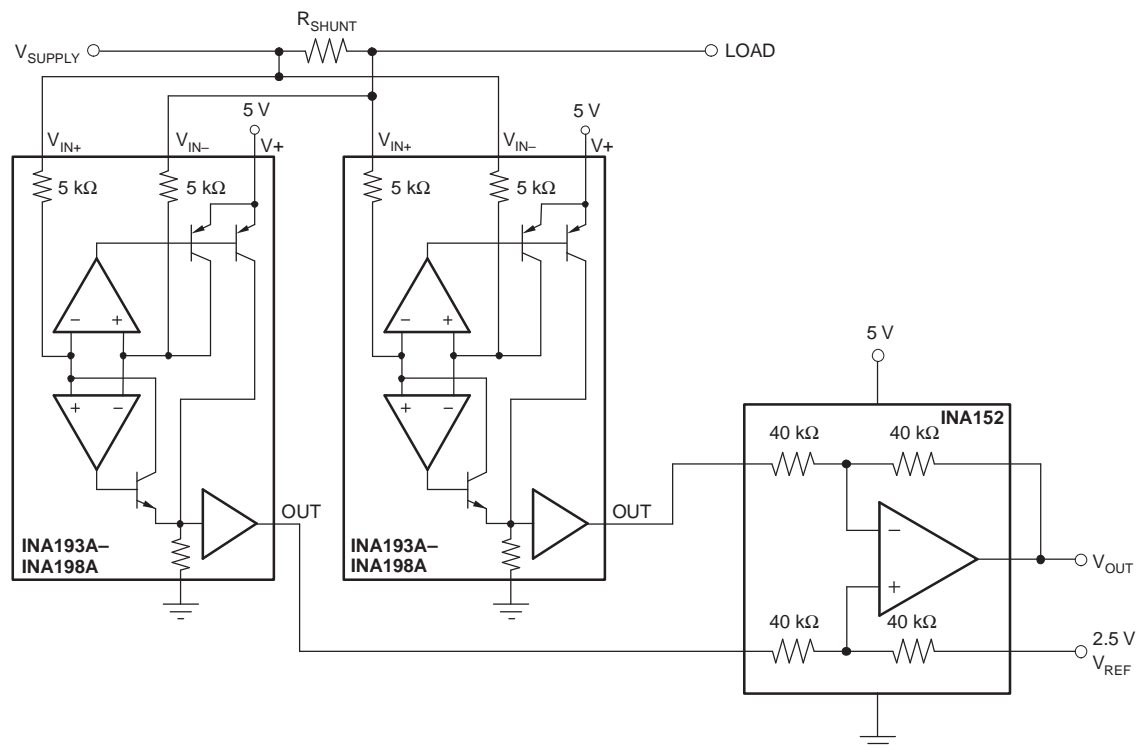

Figure 29. Bidirectional Current Monitoring

8.2.1 Design Requirements

V_{supply} is set to 12V , V_{ref} at 2.5V and a $10\text{-m}\Omega$ shunt. The accuracy of the current will typically be less than 0.5% for current greater than $\pm 2\text{A}$. For current lower than $\pm 2\text{A}$, the accuracy will vary; use the [Accuracy Variations as a Result Of \$V_{SENSE}\$ and Common Mode Voltage](#) section for accuracy considerations.

Typical Application (continued)

8.2.2 Detailed Design Procedure

The ability to measure this current flowing in both directions is enabled by adding a unity gain amplifier with a V_{REF} , as shown in Figure 29. The output then responds by increasing above V_{REF} for positive differential signals (relative to the IN – pin) and responds by decreasing below V_{REF} for negative differential signals. This reference voltage applied to the REF pin can be set anywhere from 0 V to $V+$. For bidirectional applications, V_{REF} is typically set at mid-scale for equal signal range in both current directions. In some cases, however, V_{REF} is set at a voltage other than mid-scale when the bidirectional current and corresponding output signal are not required to be symmetrical.

8.2.3 Application Curve

An example output response of a bidirectional configuration is shown in Figure 30. With the REF pin connected to a reference voltage, 2.5 V in this case, the output voltage is biased upwards by this reference level. The output rises above the reference voltage for positive differential input signals and falls below the reference voltage for negative differential input signals.

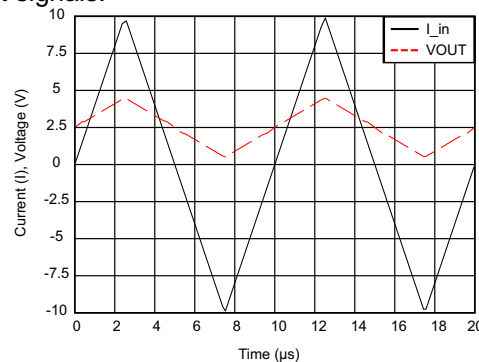

Figure 30. Output Voltage vs Shunt Input Current

9 Power Supply Recommendations

The input circuitry of the INA193A-INA198A devices can accurately measure beyond its power-supply voltage, $V+$. For example, the $V+$ power supply can be 5 V, whereas the load power-supply voltage is up to 80 V. The output voltage range of the OUT terminal, however, is limited by the voltages on the power-supply pin.

10 Layout

10.1 Layout Guidelines

10.1.1 RFI/EMI

TI always recommends adhering to good layout practices. Keep traces short and, when possible, use a printed-circuit-board (PCB) ground plane with surface-mount components placed as close to the device pins as possible. Small ceramic capacitors placed directly across amplifier inputs can reduce RFI/EMI sensitivity. PCB layout should locate the amplifier as far away as possible from RFI sources. Sources can include other components in the same system as the amplifier itself, such as inductors (particularly switched inductors handling a lot of current and at high frequencies). RFI can generally be identified as a variation in offset voltage or dc signal levels with changes in the interfering RF signal. If the amplifier cannot be located away from sources of radiation, shielding may be needed. Twisting wire input leads makes them more resistant to RF fields. The difference in input pin location of the INA193A–INA195A versus the INA196A–INA198A may provide different EMI performance.

10.2 Layout Example

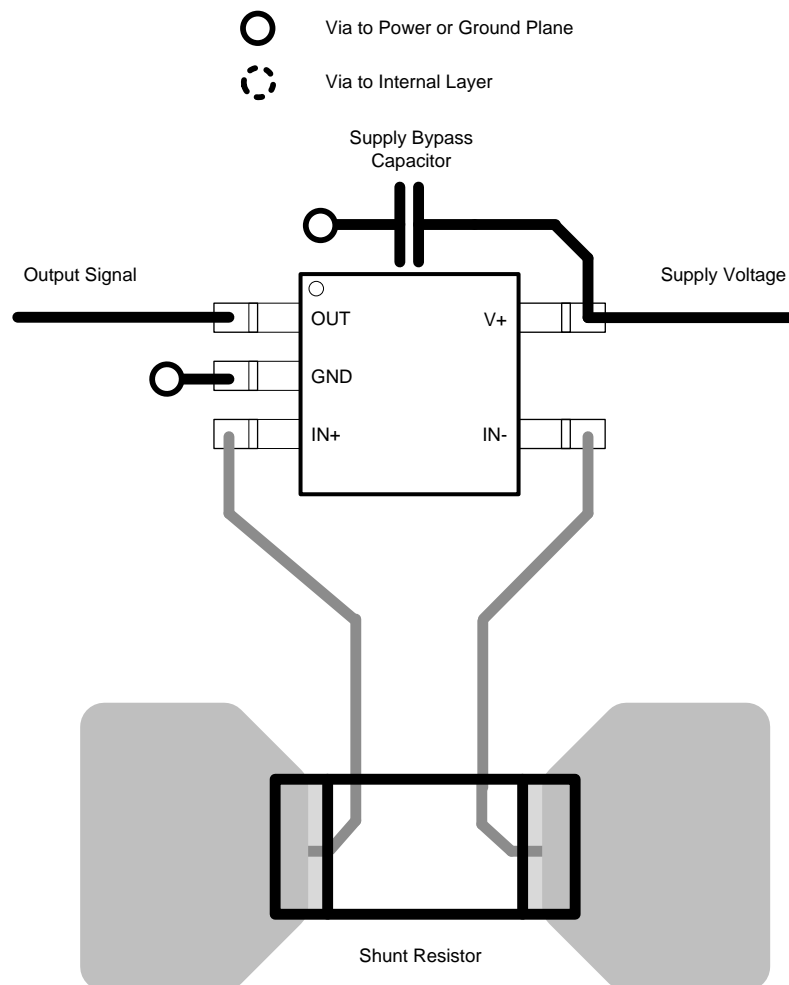

Figure 31. Recommended Layout

11 Device and Documentation Support

11.1 Related Links

[Table 1](#) lists quick access links. Categories include technical documents, support and community resources, tools and software, and quick access to sample or buy.

Table 1. Related Links

PARTS	PRODUCT FOLDER	SAMPLE & BUY	TECHNICAL DOCUMENTS	TOOLS & SOFTWARE	SUPPORT & COMMUNITY
INA193A-Q1	Click here	Click here	Click here	Click here	Click here
INA194A-Q1	Click here	Click here	Click here	Click here	Click here
INA195A-Q1	Click here	Click here	Click here	Click here	Click here
INA196A-Q1	Click here	Click here	Click here	Click here	Click here
INA197A-Q1	Click here	Click here	Click here	Click here	Click here
INA198A-Q1	Click here	Click here	Click here	Click here	Click here

11.2 Receiving Notification of Documentation Updates

To receive notification of documentation updates, navigate to the device product folder on ti.com. In the upper right corner, click on *Alert me* to register and receive a weekly digest of any product information that has changed. For change details, review the revision history included in any revised document.

11.3 Community Resources

The following links connect to TI community resources. Linked contents are provided "AS IS" by the respective contributors. They do not constitute TI specifications and do not necessarily reflect TI's views; see TI's [Terms of Use](#).

TI E2E™ Online Community *TI's Engineer-to-Engineer (E2E) Community*. Created to foster collaboration among engineers. At e2e.ti.com, you can ask questions, share knowledge, explore ideas and help solve problems with fellow engineers.

Design Support *TI's Design Support* Quickly find helpful E2E forums along with design support tools and contact information for technical support.

11.4 Trademarks

E2E is a trademark of Texas Instruments.
All other trademarks are the property of their respective owners.

11.5 Electrostatic Discharge Caution



These devices have limited built-in ESD protection. The leads should be shorted together or the device placed in conductive foam during storage or handling to prevent electrostatic damage to the MOS gates.

11.6 Glossary

[SLYZ022](#) — *TI Glossary*.

This glossary lists and explains terms, acronyms, and definitions.

12 Mechanical, Packaging, and Orderable Information

The following pages include mechanical, packaging, and orderable information. This information is the most current data available for the designated devices. This data is subject to change without notice and revision of this document. For browser-based versions of this data sheet, refer to the left-hand navigation.

PACKAGING INFORMATION

Orderable Device	Status (1)	Package Type	Package Drawing	Pins	Package Qty	Eco Plan (2)	Lead/Ball Finish (6)	MSL Peak Temp (3)	Op Temp (°C)	Device Marking (4/5)	Samples
INA193AQDBVRQ1	ACTIVE	SOT-23	DBV	5	3000	Green (RoHS & no Sb/Br)	CU NIPDAU	Level-2-260C-1 YEAR	-40 to 125	BOG	Samples
INA194AQDBVRQ1	ACTIVE	SOT-23	DBV	5	3000	Green (RoHS & no Sb/Br)	CU NIPDAU	Level-2-260C-1 YEAR	-40 to 125	BOH	Samples
INA195AQDBVRQ1	ACTIVE	SOT-23	DBV	5	3000	Green (RoHS & no Sb/Br)	CU NIPDAU	Level-2-260C-1 YEAR	-40 to 125	BOI	Samples
INA196AQDBVRQ1	ACTIVE	SOT-23	DBV	5	3000	Green (RoHS & no Sb/Br)	CU NIPDAU	Level-2-260C-1 YEAR	-40 to 125	BOJ	Samples
INA197AQDBVRQ1	ACTIVE	SOT-23	DBV	5	3000	Green (RoHS & no Sb/Br)	CU NIPDAU	Level-2-260C-1 YEAR	-40 to 125	BOK	Samples
INA198AQDBVRQ1	ACTIVE	SOT-23	DBV	5	3000	Green (RoHS & no Sb/Br)	CU NIPDAU	Level-2-260C-1 YEAR	-40 to 125	BOL	Samples

(1) The marketing status values are defined as follows:

ACTIVE: Product device recommended for new designs.

LIFEBUY: TI has announced that the device will be discontinued, and a lifetime-buy period is in effect.

NRND: Not recommended for new designs. Device is in production to support existing customers, but TI does not recommend using this part in a new design.

PREVIEW: Device has been announced but is not in production. Samples may or may not be available.

OBSELETE: TI has discontinued the production of the device.

(2) Eco Plan - The planned eco-friendly classification: Pb-Free (RoHS), Pb-Free (RoHS Exempt), or Green (RoHS & no Sb/Br) - please check <http://www.ti.com/productcontent> for the latest availability information and additional product content details.

TBD: The Pb-Free/Green conversion plan has not been defined.

Pb-Free (RoHS): TI's terms "Lead-Free" or "Pb-Free" mean semiconductor products that are compatible with the current RoHS requirements for all 6 substances, including the requirement that lead not exceed 0.1% by weight in homogeneous materials. Where designed to be soldered at high temperatures, TI Pb-Free products are suitable for use in specified lead-free processes.

Pb-Free (RoHS Exempt): This component has a RoHS exemption for either 1) lead-based flip-chip solder bumps used between the die and package, or 2) lead-based die adhesive used between the die and leadframe. The component is otherwise considered Pb-Free (RoHS compatible) as defined above.

Green (RoHS & no Sb/Br): TI defines "Green" to mean Pb-Free (RoHS compatible), and free of Bromine (Br) and Antimony (Sb) based flame retardants (Br or Sb do not exceed 0.1% by weight in homogeneous material)

(3) MSL, Peak Temp. - The Moisture Sensitivity Level rating according to the JEDEC industry standard classifications, and peak solder temperature.

(4) There may be additional marking, which relates to the logo, the lot trace code information, or the environmental category on the device.

(5) Multiple Device Markings will be inside parentheses. Only one Device Marking contained in parentheses and separated by a "~" will appear on a device. If a line is indented then it is a continuation of the previous line and the two combined represent the entire Device Marking for that device.

⁽⁶⁾ Lead/Ball Finish - Orderable Devices may have multiple material finish options. Finish options are separated by a vertical ruled line. Lead/Ball Finish values may wrap to two lines if the finish value exceeds the maximum column width.

Important Information and Disclaimer: The information provided on this page represents TI's knowledge and belief as of the date that it is provided. TI bases its knowledge and belief on information provided by third parties, and makes no representation or warranty as to the accuracy of such information. Efforts are underway to better integrate information from third parties. TI has taken and continues to take reasonable steps to provide representative and accurate information but may not have conducted destructive testing or chemical analysis on incoming materials and chemicals. TI and TI suppliers consider certain information to be proprietary, and thus CAS numbers and other limited information may not be available for release.

In no event shall TI's liability arising out of such information exceed the total purchase price of the TI part(s) at issue in this document sold by TI to Customer on an annual basis.

TAPE AND REEL INFORMATION

QUADRANT ASSIGNMENTS FOR PIN 1 ORIENTATION IN TAPE

*All dimensions are nominal

Device	Package Type	Package Drawing	Pins	SPQ	Reel Diameter (mm)	Reel Width W1 (mm)	A0 (mm)	B0 (mm)	K0 (mm)	P1 (mm)	W (mm)	Pin1 Quadrant
INA193AQDBVRQ1	SOT-23	DBV	5	3000	178.0	9.0	3.3	3.2	1.4	4.0	8.0	Q3
INA194AQDBVRQ1	SOT-23	DBV	5	3000	178.0	9.0	3.3	3.2	1.4	4.0	8.0	Q3
INA195AQDBVRQ1	SOT-23	DBV	5	3000	178.0	9.0	3.3	3.2	1.4	4.0	8.0	Q3
INA196AQDBVRQ1	SOT-23	DBV	5	3000	178.0	9.0	3.3	3.2	1.4	4.0	8.0	Q3
INA197AQDBVRQ1	SOT-23	DBV	5	3000	178.0	9.0	3.3	3.2	1.4	4.0	8.0	Q3
INA198AQDBVRQ1	SOT-23	DBV	5	3000	178.0	9.0	3.3	3.2	1.4	4.0	8.0	Q3

TAPE AND REEL BOX DIMENSIONS

*All dimensions are nominal

Device	Package Type	Package Drawing	Pins	SPQ	Length (mm)	Width (mm)	Height (mm)
INA193AQDBVRQ1	SOT-23	DBV	5	3000	190.0	190.0	30.0
INA194AQDBVRQ1	SOT-23	DBV	5	3000	190.0	190.0	30.0
INA195AQDBVRQ1	SOT-23	DBV	5	3000	190.0	190.0	30.0
INA196AQDBVRQ1	SOT-23	DBV	5	3000	190.0	190.0	30.0
INA197AQDBVRQ1	SOT-23	DBV	5	3000	190.0	190.0	30.0
INA198AQDBVRQ1	SOT-23	DBV	5	3000	190.0	190.0	30.0

DBV0005A



PACKAGE OUTLINE

SOT-23 - 1.45 mm max height

SMALL OUTLINE TRANSISTOR



4214839/D 11/2018

NOTES:

1. All linear dimensions are in millimeters. Any dimensions in parenthesis are for reference only. Dimensioning and tolerancing per ASME Y14.5M.
2. This drawing is subject to change without notice.
3. Reference JEDEC MO-178.
4. Body dimensions do not include mold flash, protrusions, or gate burrs. Mold flash, protrusions, or gate burrs shall not exceed 0.15 mm per side.

EXAMPLE BOARD LAYOUT

DBV0005A

SOT-23 - 1.45 mm max height

SMALL OUTLINE TRANSISTOR



LAND PATTERN EXAMPLE
EXPOSED METAL SHOWN
SCALE:15X



SOLDER MASK DETAILS

4214839/D 11/2018

NOTES: (continued)

- 5. Publication IPC-7351 may have alternate designs.
- 6. Solder mask tolerances between and around signal pads can vary based on board fabrication site.

EXAMPLE STENCIL DESIGN

DBV0005A

SOT-23 - 1.45 mm max height

SMALL OUTLINE TRANSISTOR



SOLDER PASTE EXAMPLE
BASED ON 0.125 mm THICK STENCIL
SCALE:15X

4214839/D 11/2018

NOTES: (continued)

7. Laser cutting apertures with trapezoidal walls and rounded corners may offer better paste release. IPC-7525 may have alternate design recommendations.
8. Board assembly site may have different recommendations for stencil design.

IMPORTANT NOTICE AND DISCLAIMER

TI PROVIDES TECHNICAL AND RELIABILITY DATA (INCLUDING DATASHEETS), DESIGN RESOURCES (INCLUDING REFERENCE DESIGNS), APPLICATION OR OTHER DESIGN ADVICE, WEB TOOLS, SAFETY INFORMATION, AND OTHER RESOURCES "AS IS" AND WITH ALL FAULTS, AND DISCLAIMS ALL WARRANTIES, EXPRESS AND IMPLIED, INCLUDING WITHOUT LIMITATION ANY IMPLIED WARRANTIES OF MERCHANTABILITY, FITNESS FOR A PARTICULAR PURPOSE OR NON-INFRINGEMENT OF THIRD PARTY INTELLECTUAL PROPERTY RIGHTS.

These resources are intended for skilled developers designing with TI products. You are solely responsible for (1) selecting the appropriate TI products for your application, (2) designing, validating and testing your application, and (3) ensuring your application meets applicable standards, and any other safety, security, or other requirements. These resources are subject to change without notice. TI grants you permission to use these resources only for development of an application that uses the TI products described in the resource. Other reproduction and display of these resources is prohibited. No license is granted to any other TI intellectual property right or to any third party intellectual property right. TI disclaims responsibility for, and you will fully indemnify TI and its representatives against, any claims, damages, costs, losses, and liabilities arising out of your use of these resources.

TI's products are provided subject to TI's Terms of Sale (www.ti.com/legal/termsofsale.html) or other applicable terms available either on ti.com or provided in conjunction with such TI products. TI's provision of these resources does not expand or otherwise alter TI's applicable warranties or warranty disclaimers for TI products.

Mailing Address: Texas Instruments, Post Office Box 655303, Dallas, Texas 75265
Copyright © 2019, Texas Instruments Incorporated

Looking for pricing, stock, or lifecycle information?

Click below to explore more details on WIN SOURCE:

 [View INA196AQDBVRQ1](#) on WIN SOURCE

 [Texas Instruments](#) Information

Optimize Your Supply Chain with WIN SOURCE Solutions

-  Global Sourcing Solution
-  Obsolete Management
-  Cost Control Management
-  Shortage Management
-  Alternative Solution
-  Excess Inventory Management