

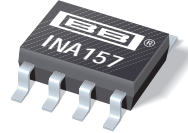

**THE DATASHEET OF
INA157UA/2K5**





INA157

For most current data sheet and other product information, visit www.burr-brown.com

High-Speed, Precision DIFFERENCE AMPLIFIER

FEATURES

- DESIGNED FOR LOW COST
- LOW OFFSET VOLTAGE: $\pm 500\mu\text{V}$ max
- LOW OFFSET DRIFT: $\pm 2\mu\text{V}/^\circ\text{C}$
- LOW GAIN ERROR: $\pm 0.05\%$ max
- WIDE BANDWIDTH: 3MHz
- HIGH SLEW RATE: $14\text{V}/\mu\text{s}$
- FAST SETTLING TIME: $3\mu\text{s}$ to 0.01%
- WIDE SUPPLY RANGE: $\pm 4\text{V}$ to $\pm 18\text{V}$
- LOW QUIESCENT CURRENT: 2.4mA
- SO-8 SURFACE-MOUNT PACKAGE

APPLICATIONS

- DIFFERENTIAL INPUT AMPLIFIER
- INSTRUMENTATION AMPLIFIER BUILDING BLOCK
- $G = 1/2$ AMPLIFIER
- $G = 2$ AMPLIFIER
- DIFFERENTIAL CURRENT RECEIVER
- VOLTAGE-CONTROLLED CURRENT SOURCE
- GROUND LOOP ELIMINATOR
- CURRENT SHUNT MONITOR

DESCRIPTION

The INA157 is a high slew rate, $G = 1/2$ or $G = 2$ difference amplifier consisting of a precision op amp with a precision resistor network. The on-chip resistors are laser trimmed for accurate gain and high common-mode rejection. Excellent TCR tracking of the resistors maintains gain accuracy and common-mode rejection over temperature. The input common-mode voltage range extends beyond the positive and negative supply rails. It operates on $\pm 4\text{V}$ to $\pm 18\text{V}$ supplies.

The difference amplifier is the foundation of many commonly used circuits. The INA157 provides this circuit function without using an expensive precision resistor network. The INA157 is available in a SO-8 surface-mount package and is specified for operation over the extended industrial temperature range, -40°C to $+85^\circ\text{C}$.

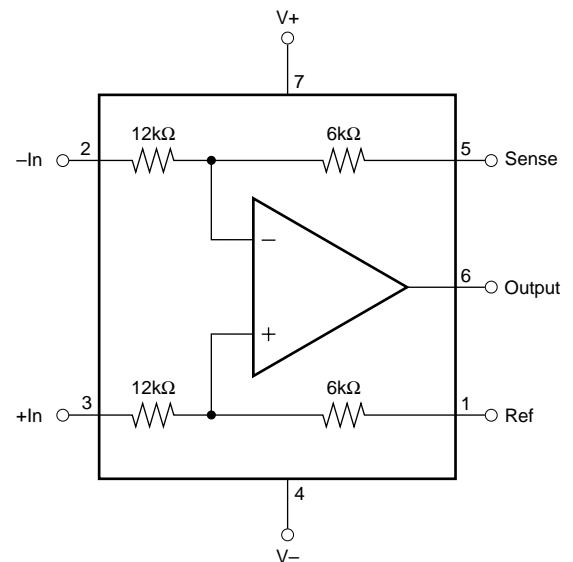

SPECIFICATIONS: $V_S = \pm 15V$

At $T_A = +25^\circ C$, $V_S = \pm 15V$, $R_L = 2k\Omega$ connected to ground, and reference pin connected to ground, unless otherwise noted.

PARAMETER	CONDITIONS	INA157U			INA157UA			UNITS
		MIN	TYP	MAX	MIN	TYP	MAX	
OFFSET VOLTAGE⁽¹⁾ Initial ⁽¹⁾ vs Temperature vs Power Supply vs Time	RTO $V_S = \pm 4V$ to $\pm 18V$		± 100 ± 2 ± 5 0.25	± 500 ± 20 ± 60		*	± 1000 * *	μV $\mu V/^\circ C$ $\mu V/V$ $\mu V/mo$
INPUT IMPEDANCE⁽²⁾ Differential Common-Mode			24 18			*		$k\Omega$ $k\Omega$
INPUT VOLTAGE RANGE Common-Mode Voltage Range Positive Negative Common-Mode Rejection Ratio	$V_O = 0V$ $V_O = 0V$ $V_{CM} = -37.5V$ to $37.5V$, $R_S = 0\Omega$	$3(V+) - 7.5$ $3(V-) + 7.5$ 86	$3(V+) - 6$ $3(V-) + 3$ 96		*	*	*	V V dB
OUTPUT VOLTAGE NOISE⁽³⁾ $f = 0.1Hz$ to $10Hz$ $f = 1kHz$	RTO		1.3 26			*		$\mu Vp-p$ nV/\sqrt{Hz}
GAIN Initial Error vs Temperature Nonlinearity	$V_O = -10V$ to $+10V$ $V_O = -10V$ to $+10V$		0.5 ± 0.01 ± 1 ± 0.0001	± 0.05 ± 10 ± 0.001		*	*	V/V % $ppm/^\circ C$ % of FS
OUTPUT Voltage, Positive Negative Current Limit, Continuous to Common Capacitive Load (stable operation)		$(V+) - 2$ $(V-) + 2$	$(V+) - 1.8$ $(V-) + 1.6$ ± 60 500		*	*	*	V V mA pF
FREQUENCY RESPONSE Small-Signal Bandwidth Slew Rate Settling Time: 0.1% 0.01% Overload Recovery Time	-3dB 10V Step, $C_L = 100pF$ 10V Step, $C_L = 100pF$ 50% Overdrive		4 14 2 3 3			*	*	MHz $V/\mu s$ μs μs μs
POWER SUPPLY Rated Voltage Operating Voltage Range Quiescent Current	 $I_O = 0mA$		± 4 ± 2.4	± 15 ± 18 ± 2.9		*	*	V V mA
TEMPERATURE RANGE Specified Operation Storage Thermal Resistance, θ_{JA} SO-8 Surface-Mount		-40 -55 -55		+85 +125 +125	*		*	$^\circ C$ $^\circ C$ $^\circ C$ $^\circ C/W$

*Specifications the same as INA157U.

NOTES: (1) Includes effects of amplifier's input bias and offset currents. (2) Internal resistors are ratio matched but have $\pm 20\%$ absolute value. (3) Includes effects of amplifier's input current noise and thermal noise contribution of resistor network.

The information provided herein is believed to be reliable; however, BURR-BROWN assumes no responsibility for inaccuracies or omissions. BURR-BROWN assumes no responsibility for the use of this information, and all use of such information shall be entirely at the user's own risk. Prices and specifications are subject to change without notice. No patent rights or licenses to any of the circuits described herein are implied or granted to any third party. BURR-BROWN does not authorize or warrant any BURR-BROWN product for use in life support devices and/or systems.

PIN CONFIGURATION

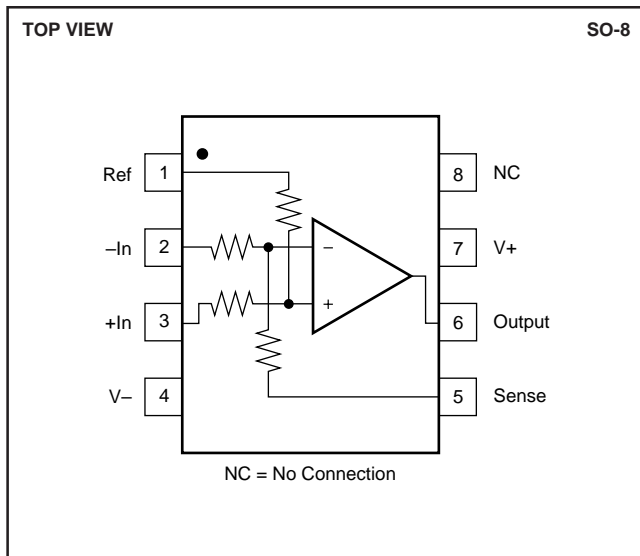

ABSOLUTE MAXIMUM RATINGS⁽¹⁾

Supply Voltage, V+ to V-	40V
Input Voltage Range	±80V
Output Short Circuit (to ground)	Continuous
Operating Temperature	-55°C to +125°C
Storage Temperature	-55°C to +125°C
Junction Temperature	+150°C
Lead Temperature (soldering, 10s)	+300°C

NOTE: (1) Stresses above these ratings may cause permanent damage. Exposure to absolute maximum conditions for extended periods may degrade device reliability.



ELECTROSTATIC DISCHARGE SENSITIVITY

This integrated circuit can be damaged by ESD. Burr-Brown recommends that all integrated circuits be handled with appropriate precautions. Failure to observe proper handling and installation procedures can cause damage.

ESD damage can range from subtle performance degradation to complete device failure. Precision integrated circuits may be more susceptible to damage because very small parametric changes could cause the device not to meet its published specifications.

PACKAGE/ORDERING INFORMATION

PRODUCT	PACKAGE	PACKAGE DRAWING NUMBER ⁽¹⁾	SPECIFIED TEMPERATURE RANGE	PACKAGE MARKING	ORDERING NUMBER ⁽²⁾	TRANSPORT MEDIA
INA157U	SO-8 Surface-Mount	182	-40°C to +85°C	INA157U	INA157U	Rails
"	"	"	"	"	INA157U/2K5	Tape and Reel
INA157UA	SO-8 Surface-Mount	182	-40°C to +85°C	INA157UA	INA157UA	Rails
"	"	"	"	"	INA157UA/2K5	Tape and Reel

NOTES: (1) For detailed drawing and dimension table, please see end of data sheet, or Appendix C of Burr-Brown IC Data Book. (2) Models with a slash (/) are available only in Tape and Reel in the quantities indicated (e.g., /2K5 indicates 2500 devices per reel). Ordering 2500 pieces of "INA157U/2K5" will get a single 2500-piece Tape and Reel. For detailed Tape and Reel mechanical information, refer to Appendix B of Burr-Brown IC Data Book.

TYPICAL PERFORMANCE CURVES

At $T_A = +25^\circ\text{C}$, $V_S = \pm 15\text{V}$, and $G = 1/2$, unless otherwise noted.

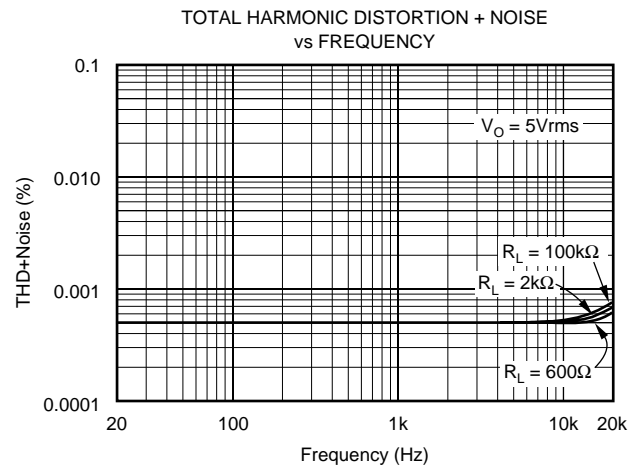
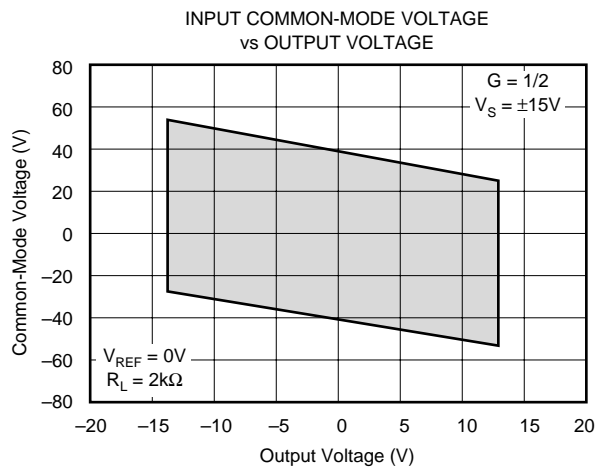
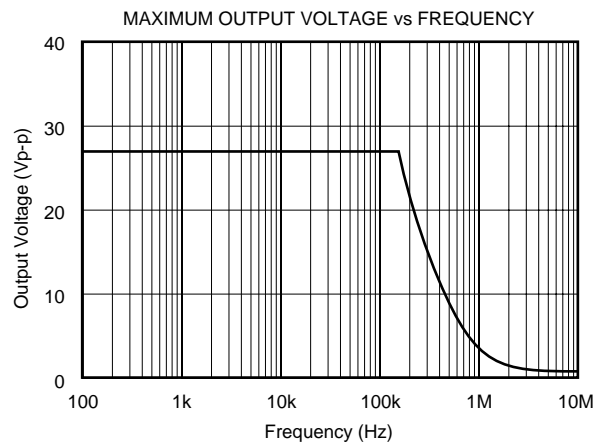
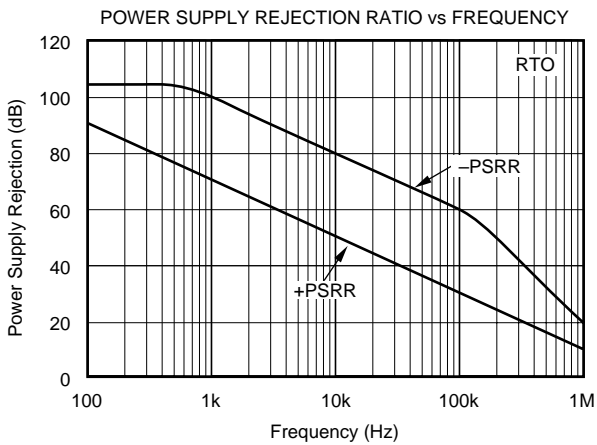
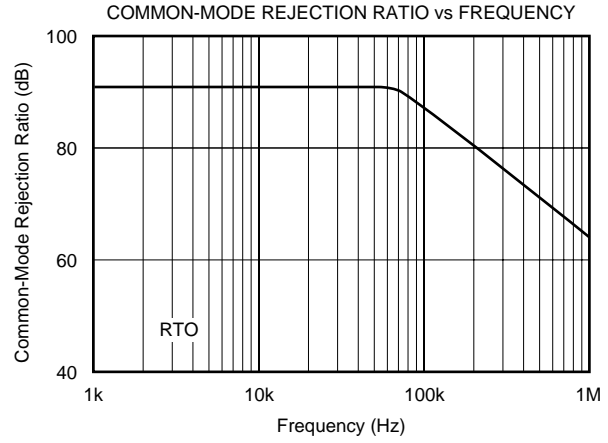
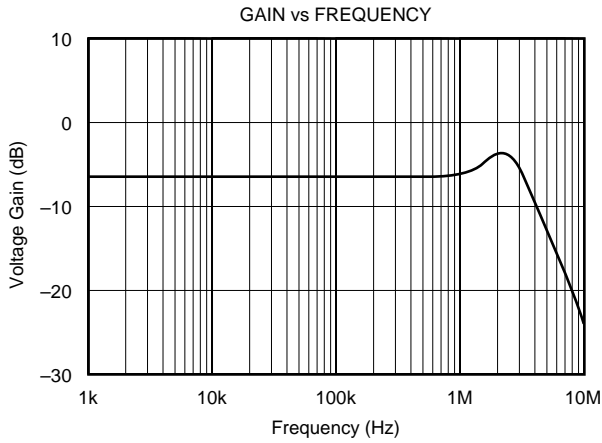

TYPICAL PERFORMANCE CURVES (CONT)

At $T_A = +25^\circ\text{C}$, $V_S = \pm 15\text{V}$, and $G = 1/2$, unless otherwise noted.

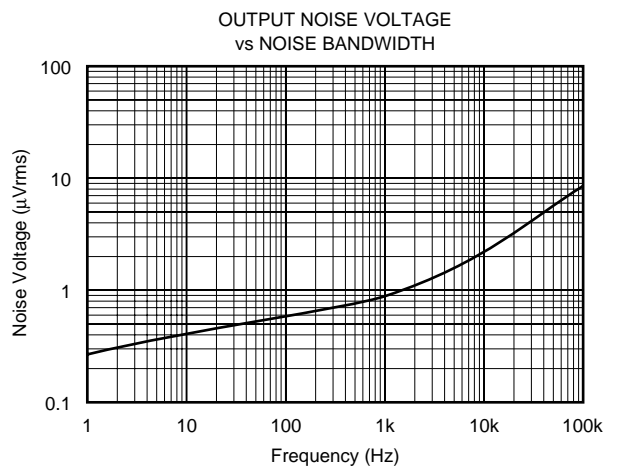
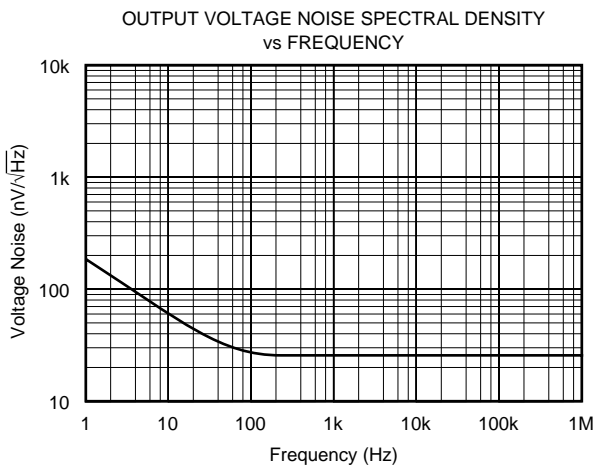
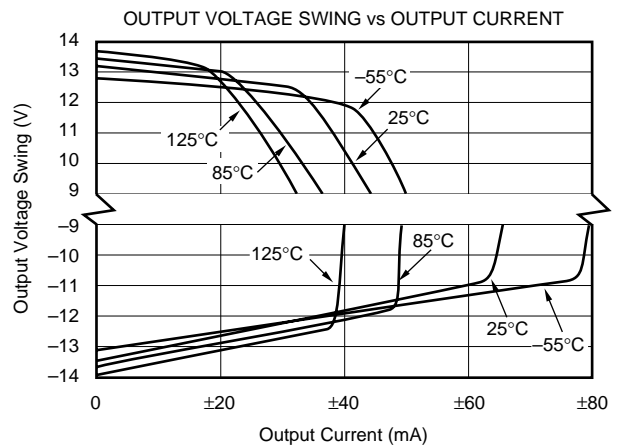
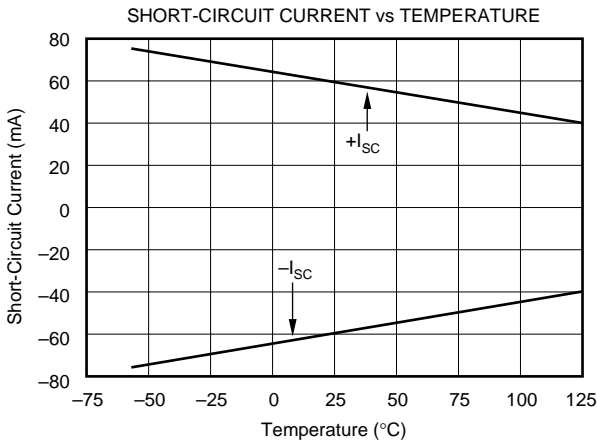
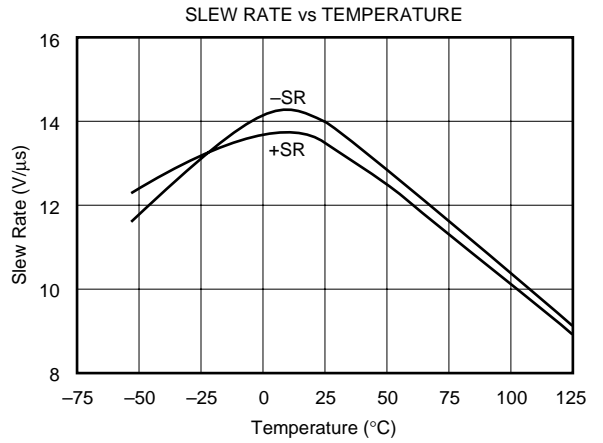
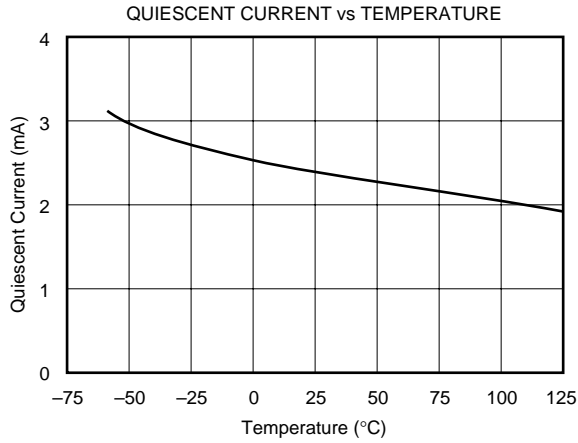

TYPICAL PERFORMANCE CURVES (CONT)

At $T_A = +25^\circ\text{C}$, $V_S = \pm 15\text{V}$, and $G = 1/2$, unless otherwise noted.

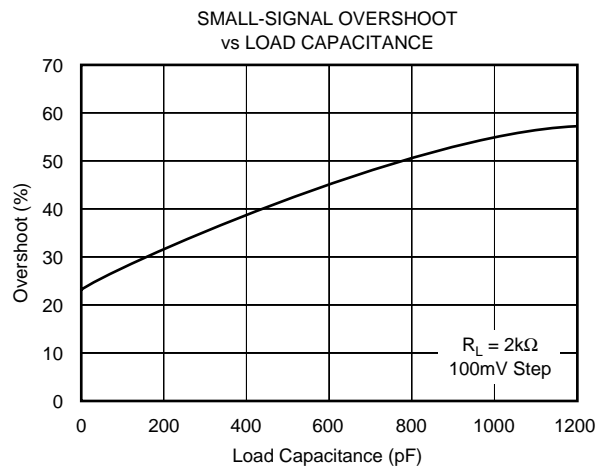
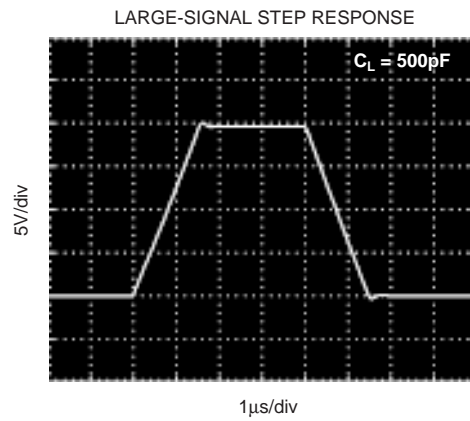
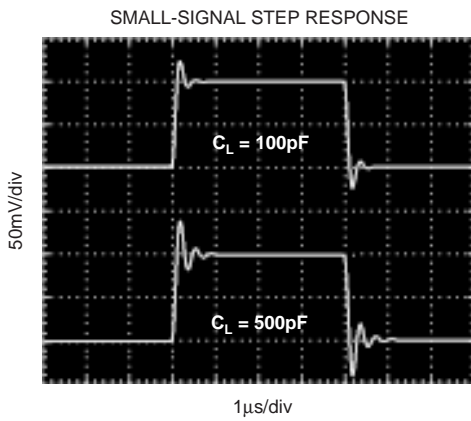
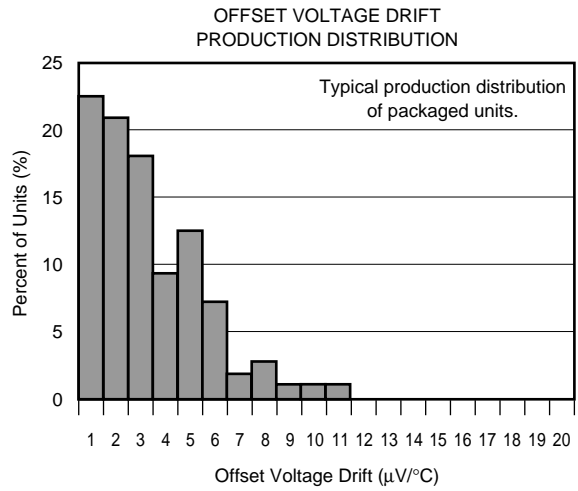
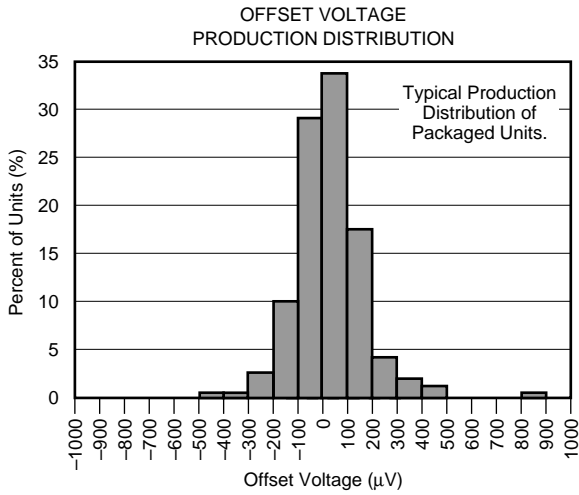

APPLICATIONS INFORMATION

The INA157 is a difference amplifier suitable for a wide range of general-purpose applications. Figure 1 shows the basic $G = 1/2$ configuration. The input and feedback resistors can be reversed to achieve $G = 2$, as shown in Figure 2. For applications requiring $G = 1$, the INA154 is recommended.

Decoupling capacitors are strongly recommended for applications with noisy or high impedance power supplies. The capacitors should be placed close to the device pins as shown in Figure 1.

As shown in Figure 1, the output is referred to the reference terminal (pin 1). A voltage applied to this pin will be summed with the output signal. The differential input signal is connected to pins 2 and 3. The source impedances connected to the inputs must be nearly equal to assure good common-mode rejection. A 5Ω mismatch in source impedance will degrade the common-mode rejection of a typical device to approximately 77dB (RTO). If the source has a known impedance mismatch, an additional resistor in series with the opposite input can be used to preserve good common-mode rejection.

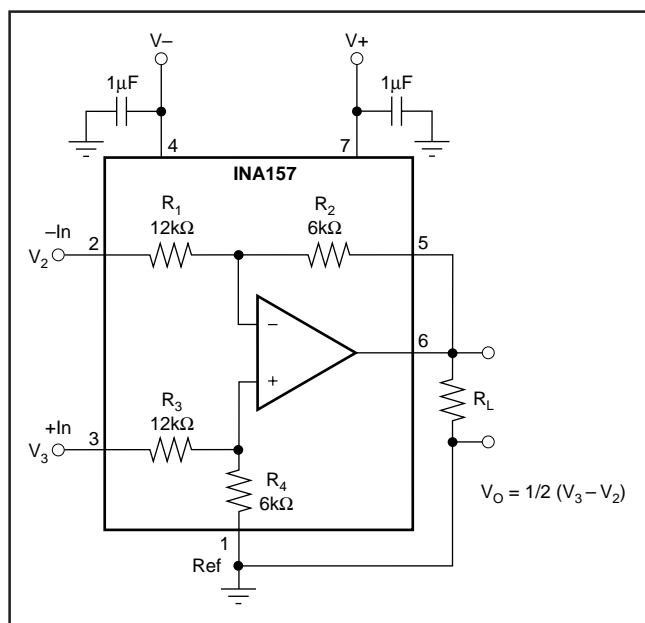

FIGURE 1. $G = 1/2$ Differential Amplifier (basic power supply and signal connections).

OPERATING VOLTAGE

The INA157 operates from $\pm 4V$ to $\pm 18V$ supplies with excellent performance. Most behavior remains unchanged throughout the full operating voltage range. Parameters which vary significantly with operating voltage are shown in the Typical Performance Curves.

INPUT VOLTAGE RANGE

The INA157 can accurately measure differential signals that are above the positive or negative power supply rail. In a gain of $1/2$, the linear common-mode range extends from $3 \cdot (V+) - 7.5V$ to $3 \cdot (V-) + 7.5V$. See the Typical Performance Curve, "Input Common-Mode Range vs Output Voltage."

OFFSET VOLTAGE TRIM

The INA157 is laser trimmed for low offset voltage and drift. Most applications require no external offset adjustment. Figure 3 shows an optional circuit for trimming the output offset voltage. The output is referred to the output reference terminal (pin 1), which is normally grounded. A voltage applied to the Ref terminal will be summed with the output signal. This can be used to null offset voltage as shown in Figure 3. The source impedance of a signal applied to the Ref terminal should be less than 10Ω to maintain good common-mode rejection.

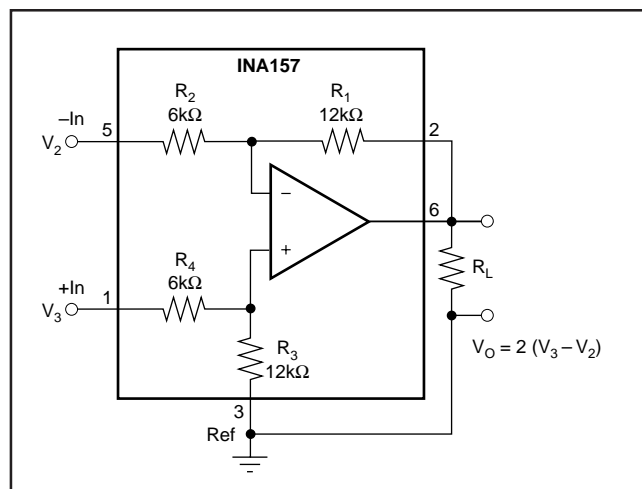

FIGURE 2. $G = 2$ Differential Amplifier.

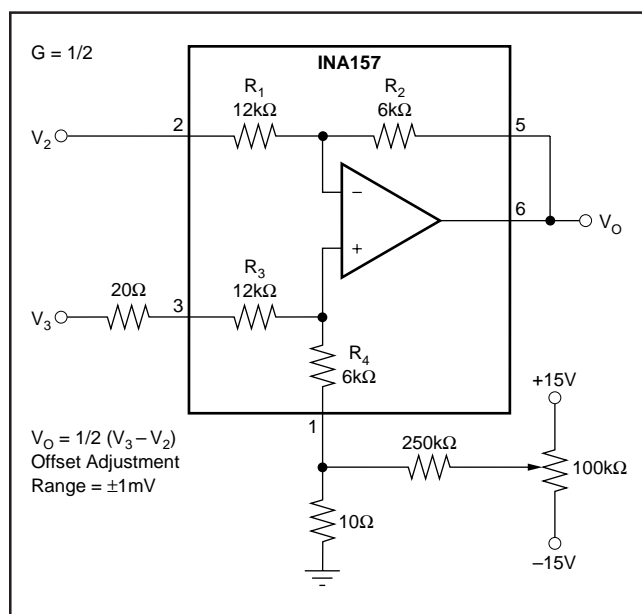

FIGURE 3. Offset Adjustment.

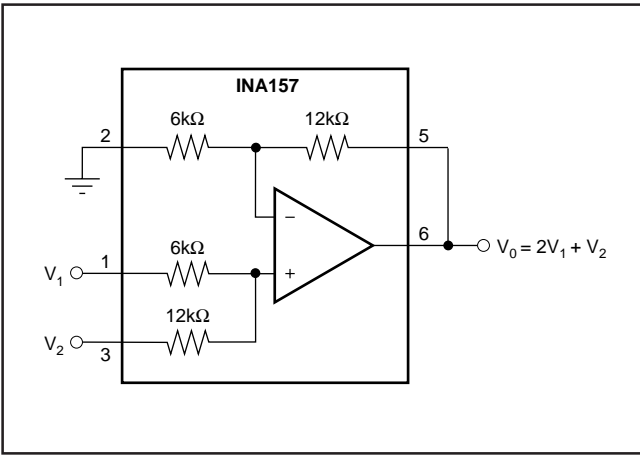

FIGURE 4. Precision Summing Amplifier.

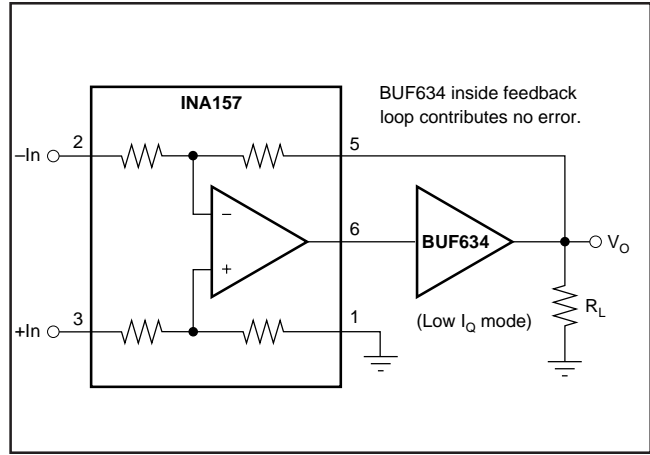

FIGURE 6. Boosting Output Current.

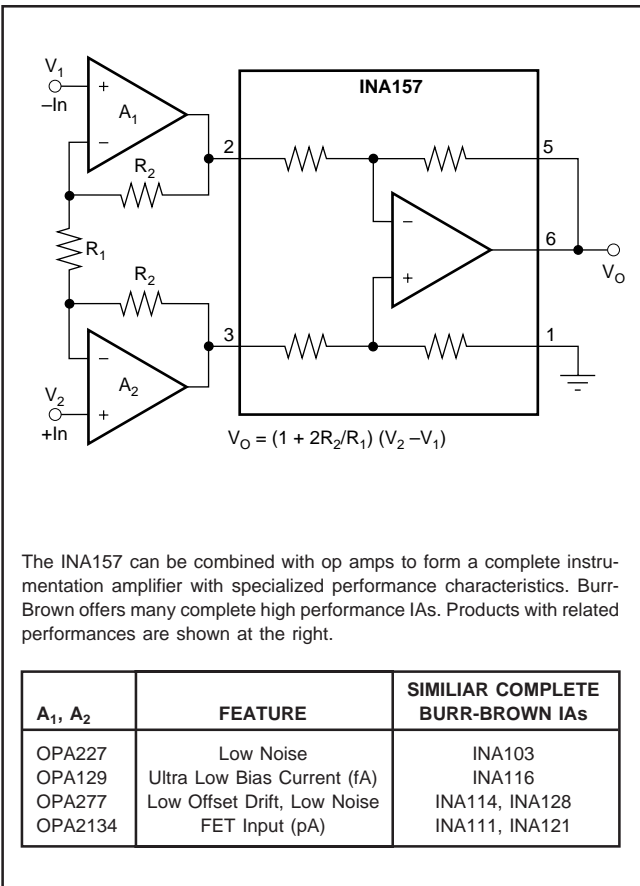

FIGURE 5. Precision Instrumentation Amplifier.

The difference amplifier is a highly versatile building block that is useful in a wide variety of applications. See the INA105 data sheet for additional applications ideas, including:

- Current Receiver with Compliance to Rails
- $\pm 10V$ Precision Voltage Reference
- $\pm 5V$ Precision Voltage Reference
- Precision Average Value Amplifier
- Precision Bipolar Offsetting
- Precision Summing Amplifier with Gain
- Instrumentation Amplifier Guard Drive Generator
- Precision Summing Instrumentation Amplifier
- Precision Absolute Value Buffer
- Precision Voltage-to-Current Converter with Differential Inputs
- Differential Input Voltage-to-Current Converter for Low I_{OUT}
- Isolating Current Source
- Differential Output Difference Amplifier
- Isolating Current Source with Buffering Amplifier for Greater Accuracy
- Window Comparator with Window Span and Window Center Inputs
- Precision Voltage-Controlled Current Source with Buffered Differential Inputs and Gain
- Digitally Controlled Gain of ± 1 Amplifier

PACKAGING INFORMATION

Orderable Device	Status ⁽¹⁾	Package Type	Package Drawing	Pins	Package Qty	Eco Plan ⁽²⁾	Lead/Ball Finish	MSL Peak Temp ⁽³⁾
INA157U	ACTIVE	SOIC	D	8	75	Green (RoHS & no Sb/Br)	CU NIPDAU	Level-3-260C-168 HR
INA157U/2K5	ACTIVE	SOIC	D	8	2500	Green (RoHS & no Sb/Br)	CU NIPDAU	Level-3-260C-168 HR
INA157U/2K5E4	ACTIVE	SOIC	D	8	2500	Green (RoHS & no Sb/Br)	CU NIPDAU	Level-3-260C-168 HR
INA157UA	ACTIVE	SOIC	D	8	75	Green (RoHS & no Sb/Br)	CU NIPDAU	Level-3-260C-168 HR
INA157UA/2K5	ACTIVE	SOIC	D	8	2500	Green (RoHS & no Sb/Br)	CU NIPDAU	Level-3-260C-168 HR
INA157UA/2K5G4	ACTIVE	SOIC	D	8	2500	Green (RoHS & no Sb/Br)	CU NIPDAU	Level-3-260C-168 HR
INA157UAG4	ACTIVE	SOIC	D	8	75	Green (RoHS & no Sb/Br)	CU NIPDAU	Level-3-260C-168 HR
INA157UG4	ACTIVE	SOIC	D	8	75	Green (RoHS & no Sb/Br)	CU NIPDAU	Level-3-260C-168 HR

⁽¹⁾ The marketing status values are defined as follows:

ACTIVE: Product device recommended for new designs.

LIFEBUY: TI has announced that the device will be discontinued, and a lifetime-buy period is in effect.

NRND: Not recommended for new designs. Device is in production to support existing customers, but TI does not recommend using this part in a new design.

PREVIEW: Device has been announced but is not in production. Samples may or may not be available.

OBSOLETE: TI has discontinued the production of the device.

⁽²⁾ Eco Plan - The planned eco-friendly classification: Pb-Free (RoHS), Pb-Free (RoHS Exempt), or Green (RoHS & no Sb/Br) - please check <http://www.ti.com/productcontent> for the latest availability information and additional product content details.

TBD: The Pb-Free/Green conversion plan has not been defined.

Pb-Free (RoHS): TI's terms "Lead-Free" or "Pb-Free" mean semiconductor products that are compatible with the current RoHS requirements for all 6 substances, including the requirement that lead not exceed 0.1% by weight in homogeneous materials. Where designed to be soldered at high temperatures, TI Pb-Free products are suitable for use in specified lead-free processes.

Pb-Free (RoHS Exempt): This component has a RoHS exemption for either 1) lead-based flip-chip solder bumps used between the die and package, or 2) lead-based die adhesive used between the die and leadframe. The component is otherwise considered Pb-Free (RoHS compatible) as defined above.

Green (RoHS & no Sb/Br): TI defines "Green" to mean Pb-Free (RoHS compatible), and free of Bromine (Br) and Antimony (Sb) based flame retardants (Br or Sb do not exceed 0.1% by weight in homogeneous material)

⁽³⁾ MSL, Peak Temp. -- The Moisture Sensitivity Level rating according to the JEDEC industry standard classifications, and peak solder temperature.

Important Information and Disclaimer:The information provided on this page represents TI's knowledge and belief as of the date that it is provided. TI bases its knowledge and belief on information provided by third parties, and makes no representation or warranty as to the accuracy of such information. Efforts are underway to better integrate information from third parties. TI has taken and continues to take reasonable steps to provide representative and accurate information but may not have conducted destructive testing or chemical analysis on incoming materials and chemicals. TI and TI suppliers consider certain information to be proprietary, and thus CAS numbers and other limited information may not be available for release.

In no event shall TI's liability arising out of such information exceed the total purchase price of the TI part(s) at issue in this document sold by TI to Customer on an annual basis.

TAPE AND REEL INFORMATION



QUADRANT ASSIGNMENTS FOR PIN 1 ORIENTATION IN TAPE



*All dimensions are nominal

Device	Package Type	Package Drawing	Pins	SPQ	Reel Diameter (mm)	Reel Width W1 (mm)	A0 (mm)	B0 (mm)	K0 (mm)	P1 (mm)	W (mm)	Pin1 Quadrant
INA157U/2K5	SOIC	D	8	2500	330.0	12.4	6.4	5.2	2.1	8.0	12.0	Q1
INA157UA/2K5	SOIC	D	8	2500	330.0	12.4	6.4	5.2	2.1	8.0	12.0	Q1

TAPE AND REEL BOX DIMENSIONS



*All dimensions are nominal

Device	Package Type	Package Drawing	Pins	SPQ	Length (mm)	Width (mm)	Height (mm)
INA157U/2K5	SOIC	D	8	2500	346.0	346.0	29.0
INA157UA/2K5	SOIC	D	8	2500	346.0	346.0	29.0

IMPORTANT NOTICE

Texas Instruments Incorporated and its subsidiaries (TI) reserve the right to make corrections, modifications, enhancements, improvements, and other changes to its products and services at any time and to discontinue any product or service without notice. Customers should obtain the latest relevant information before placing orders and should verify that such information is current and complete. All products are sold subject to TI's terms and conditions of sale supplied at the time of order acknowledgment.

TI warrants performance of its hardware products to the specifications applicable at the time of sale in accordance with TI's standard warranty. Testing and other quality control techniques are used to the extent TI deems necessary to support this warranty. Except where mandated by government requirements, testing of all parameters of each product is not necessarily performed.

TI assumes no liability for applications assistance or customer product design. Customers are responsible for their products and applications using TI components. To minimize the risks associated with customer products and applications, customers should provide adequate design and operating safeguards.

TI does not warrant or represent that any license, either express or implied, is granted under any TI patent right, copyright, mask work right, or other TI intellectual property right relating to any combination, machine, or process in which TI products or services are used. Information published by TI regarding third-party products or services does not constitute a license from TI to use such products or services or a warranty or endorsement thereof. Use of such information may require a license from a third party under the patents or other intellectual property of the third party, or a license from TI under the patents or other intellectual property of TI.

Reproduction of TI information in TI data books or data sheets is permissible only if reproduction is without alteration and is accompanied by all associated warranties, conditions, limitations, and notices. Reproduction of this information with alteration is an unfair and deceptive business practice. TI is not responsible or liable for such altered documentation. Information of third parties may be subject to additional restrictions.

Resale of TI products or services with statements different from or beyond the parameters stated by TI for that product or service voids all express and any implied warranties for the associated TI product or service and is an unfair and deceptive business practice. TI is not responsible or liable for any such statements.

TI products are not authorized for use in safety-critical applications (such as life support) where a failure of the TI product would reasonably be expected to cause severe personal injury or death, unless officers of the parties have executed an agreement specifically governing such use. Buyers represent that they have all necessary expertise in the safety and regulatory ramifications of their applications, and acknowledge and agree that they are solely responsible for all legal, regulatory and safety-related requirements concerning their products and any use of TI products in such safety-critical applications, notwithstanding any applications-related information or support that may be provided by TI. Further, Buyers must fully indemnify TI and its representatives against any damages arising out of the use of TI products in such safety-critical applications.

TI products are neither designed nor intended for use in military/aerospace applications or environments unless the TI products are specifically designated by TI as military-grade or "enhanced plastic." Only products designated by TI as military-grade meet military specifications. Buyers acknowledge and agree that any such use of TI products which TI has not designated as military-grade is solely at the Buyer's risk, and that they are solely responsible for compliance with all legal and regulatory requirements in connection with such use.

TI products are neither designed nor intended for use in automotive applications or environments unless the specific TI products are designated by TI as compliant with ISO/TS 16949 requirements. Buyers acknowledge and agree that, if they use any non-designated products in automotive applications, TI will not be responsible for any failure to meet such requirements.

Following are URLs where you can obtain information on other Texas Instruments products and application solutions:

Products

Amplifiers	amplifier.ti.com
Data Converters	dataconverter.ti.com
DLP® Products	www.dlp.com
DSP	dsp.ti.com
Clocks and Timers	www.ti.com/clocks
Interface	interface.ti.com
Logic	logic.ti.com
Power Mgmt	power.ti.com
Microcontrollers	microcontroller.ti.com
RFID	www.ti-rfid.com
RF/IF and ZigBee® Solutions	www.ti.com/lprf

Applications

Audio	www.ti.com/audio
Automotive	www.ti.com/automotive
Broadband	www.ti.com/broadband
Digital Control	www.ti.com/digitalcontrol
Medical	www.ti.com/medical
Military	www.ti.com/military
Optical Networking	www.ti.com/opticalnetwork
Security	www.ti.com/security
Telephony	www.ti.com/telephony
Video & Imaging	www.ti.com/video
Wireless	www.ti.com/wireless

Mailing Address: Texas Instruments, Post Office Box 655303, Dallas, Texas 75265
Copyright © 2009, Texas Instruments Incorporated

Looking for pricing, stock, or lifecycle information?

Click below to explore more details on WIN SOURCE:

 [View INA157UA/2K5 on WIN SOURCE](#)

 [Texas Instruments](#) Information

Optimize Your Supply Chain with WIN SOURCE Solutions

-  Global Sourcing Solution
-  Obsolete Management
-  Cost Control Management
-  Shortage Management
-  Alternative Solution
-  Excess Inventory Management