

INA137
INA2137

AUDIO DIFFERENTIAL LINE RECEIVERS

$\pm 6\text{dB}$ ($G = 1/2$ or 2)

FEATURES

- SINGLE AND DUAL VERSIONS
- LOW DISTORTION: 0.0005% at $f = 1\text{kHz}$
- HIGH SLEW RATE: $14\text{V}/\mu\text{s}$
- FAST SETTLING TIME: $3\mu\text{s}$ to 0.01%
- WIDE SUPPLY RANGE: $\pm 4\text{V}$ to $\pm 18\text{V}$
- LOW QUIESCENT CURRENT: 2.9mA max
- HIGH CMRR: 90dB
- FIXED GAIN = $\pm 6\text{dB}$
- PACKAGES—SINGLE: 8-PIN DIP, SO-8
DUAL: 14-PIN DIP, SO-14

DESCRIPTION

The INA137 and INA2137 are differential line receivers consisting of high performance op amps with on-chip precision resistors. They are fully specified for high performance audio applications and have excellent ac specifications, including low distortion (0.0005% at 1kHz) and high slew rate ($14\text{V}/\mu\text{s}$), assuring good dynamic response. In addition, wide output voltage swing and high output drive capability allow use in a wide variety of demanding applications. The dual version features completely independent circuitry for lowest crosstalk and freedom from interaction, even when overdriven or overloaded.

The INA137 and INA2137 on-chip resistors are laser trimmed for accurate gain and optimum common-mode rejection. Furthermore, excellent TCR tracking of the resistors maintains gain accuracy and common-mode rejection over temperature. Operation is guaranteed from $\pm 4\text{V}$ to $\pm 18\text{V}$ (8V to 36V total supply).

The INA137 is available in 8-pin DIP and SO-8 surface-mount packages. The INA2137 comes in 14-pin DIP and SO-14 surface-mount packages. Both are specified for operation over the extended industrial temperature range, -40°C to $+85^\circ\text{C}$.

APPLICATIONS

- AUDIO DIFFERENTIAL LINE RECEIVER
- $G = 1/2$ OR $G = 2$ AMPLIFIER
- INSTRUMENTATION BUILDING BLOCK
- CURRENT SHUNT MONITOR
- VOLTAGE-CONTROLLED CURRENT SOURCE
- GROUND LOOP ELIMINATOR

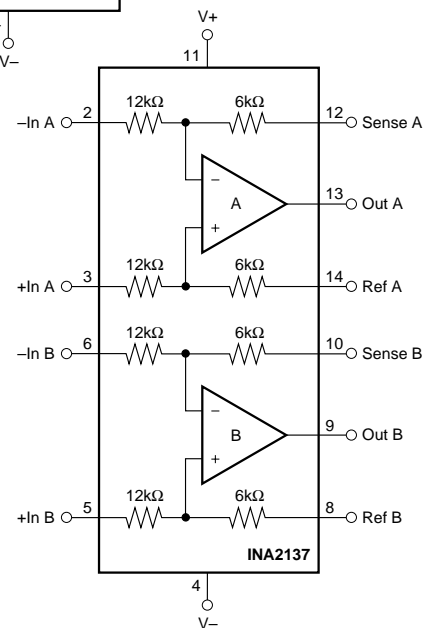
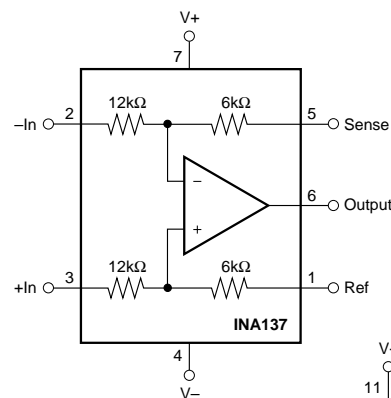

International Airport Industrial Park • Mailing Address: PO Box 11400, Tucson, AZ 85734 • Street Address: 6730 S. Tucson Blvd., Tucson, AZ 85706 • Tel: (520) 746-1111 • Twx: 910-952-1111
Internet: <http://www.burr-brown.com/> • FAXLine: (800) 548-6133 (US/Canada Only) • Cable: BBRCORP • Telex: 066-6491 • FAX: (520) 889-1510 • Immediate Product Info: (800) 548-6132

SPECIFICATIONS: $V_S = \pm 18V$

At $T_A = +25^\circ C$, $V_S = \pm 18V$, $R_L = 2k\Omega$, $G = 1/2$, and Ref Pin connected to Ground, unless otherwise noted.

PARAMETER	CONDITIONS	INA137PA, UA INA2137PA, UA			UNITS
		MIN	TYP	MAX	
AUDIO PERFORMANCE Total Harmonic Distortion + Noise, $f = 1\text{kHz}$ Noise Floor, RTO ⁽¹⁾ Headroom, RTO ⁽¹⁾	$V_{IN} = 10V_{rms}$ 20kHz BW THD+N < 1%		0.0005 -106 +23		% dBu dBu
FREQUENCY RESPONSE Small-Signal Bandwidth Slew Rate Settling Time: 0.1% 0.01% Overload Recovery Time Channel Separation (dual), $f = 1\text{kHz}$	10V Step, $C_L = 100pF$ 10V Step, $C_L = 100pF$ 50% Overdrive		4.0 14 2 3 3 123		MHz V/ μs μs μs μs dB
OUTPUT NOISE VOLTAGE ⁽²⁾ $f = 20\text{Hz}$ to 20kHz $f = 1\text{kHz}$			3.5 26		μV_{rms} nV/ \sqrt{Hz}
OFFSET VOLTAGE ⁽³⁾ Input Offset Voltage vs Temperature vs Power Supply	RTO $V_{CM} = 0V$ Specified Temperature Range $V_S = \pm 4V$ to $\pm 18V$		± 100 ± 2 ± 5	± 1000 ± 60	μV $\mu V/^\circ C$ $\mu V/V$
INPUT Common-Mode Voltage Range: Positive Negative Differential Voltage Range Common-Mode Rejection Impedance ⁽⁴⁾ Differential Common-Mode	$V_O = 0V$ $V_O = 0V$ $V_{CM} = \pm 46.5V$, $R_S = 0\Omega$	3(V+)-7.5 3(V-)+7.5 74	3(V+)-6 3(V-)+3 See Typical Curve 90 24 18		V V dB k Ω k Ω
GAIN Initial Error vs Temperature Nonlinearity	$V_O = -10V$ to $10V$ $V_O = -10V$ to $10V$		0.5 ± 0.01 ± 1 0.0001	± 0.1 ± 10	V/V % ppm/ $^\circ C$ %
OUTPUT Voltage Output, Positive Negative Current Limit, Continuous to Common Capacitive Load (Stable Operation)		(V+)-2 (V-)+2	(V+)-1.8 (V-)+1.6 ± 60 500		V V mA pF
POWER SUPPLY Rated Voltage Voltage Range Quiescent Current (per Amplifier)	 $I_O = 0$	± 4	± 18 ± 2.4	± 18 ± 2.9	V V mA
TEMPERATURE RANGE Specification Range Operation Range Storage Range Thermal Resistance, θ_{JA} 8-Pin DIP SO-8 Surface-Mount 14-Pin DIP SO-14 Surface-Mount		-40 -55 -55		85 125 125	$^\circ C$ $^\circ C$ $^\circ C$ $^\circ C/W$ $^\circ C/W$ $^\circ C/W$ $^\circ C/W$

RTO = Referred to Output.

NOTES: (1) dBu = 20log (Vrms/0.7746). (2) Includes effects of amplifier's input current noise and thermal noise contribution of resistor network. (3) Includes effects of amplifier's input bias and offset currents. (4) Internal resistors are ratio matched but have $\pm 25\%$ absolute value.

The information provided herein is believed to be reliable; however, BURR-BROWN assumes no responsibility for inaccuracies or omissions. BURR-BROWN assumes no responsibility for the use of this information, and all use of such information shall be entirely at the user's own risk. Prices and specifications are subject to change without notice. No patent rights or licenses to any of the circuits described herein are implied or granted to any third party. BURR-BROWN does not authorize or warrant any BURR-BROWN product for use in life support devices and/or systems.



PIN CONFIGURATIONS

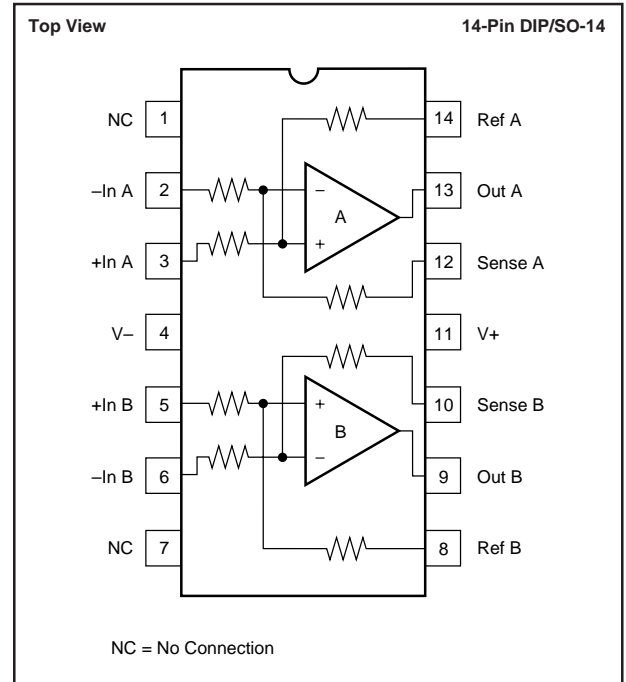
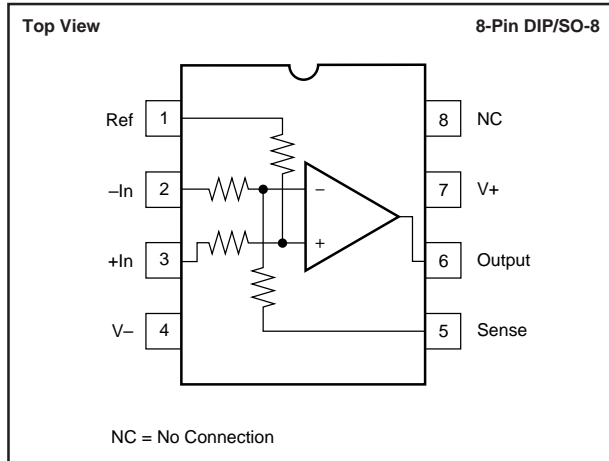

ABSOLUTE MAXIMUM RATINGS⁽¹⁾

Supply Voltage, V+ to V-	40V
Input Voltage Range	±80V
Output Short-Circuit (to ground) ⁽²⁾	Continuous
Operating Temperature	-55°C to +125°C
Storage Temperature	-55°C to +125°C
Junction Temperature	+150°C
Lead Temperature (soldering, 10s)	+300°C

NOTE: (1) Stresses above these ratings may cause permanent damage.
 (2) One channel per package.

PACKAGE/ORDERING INFORMATION

PRODUCT	PACKAGE	PACKAGE DRAWING NUMBER ⁽¹⁾	SPECIFICATION TEMPERATURE RANGE
Single			
INA137PA	8-Pin DIP	006	-40°C to +85°C
INA137UA	SO-8 Surface-Mount	182	-40°C to +85°C
Dual			
INA2137PA	14-Pin DIP	010	-40°C to +85°C
INA2137UA	SO-14 Surface-Mount	235	-40°C to +85°C

NOTE: (1) For detailed drawing and dimension table, please see end of data sheet, or Appendix C of Burr-Brown IC Data Book.

ELECTROSTATIC DISCHARGE SENSITIVITY

This integrated circuit can be damaged by ESD. Burr-Brown recommends that all integrated circuits be handled with appropriate precautions. Failure to observe proper handling and installation procedures can cause damage.

ESD damage can range from subtle performance degradation to complete device failure. Precision integrated circuits may be more susceptible to damage because very small parametric changes could cause the device not to meet its published specifications.

TYPICAL PERFORMANCE CURVES

At $T_A = +25^\circ\text{C}$, $V_S = \pm 18\text{V}$, and $G = 1/2$, unless otherwise noted.

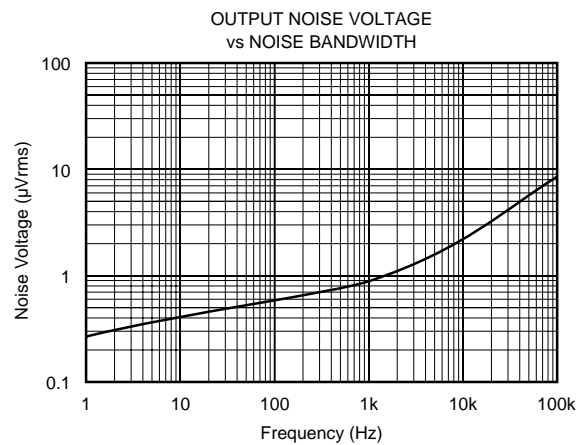
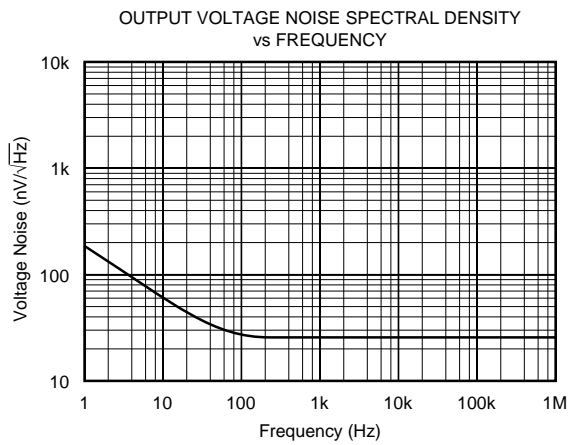
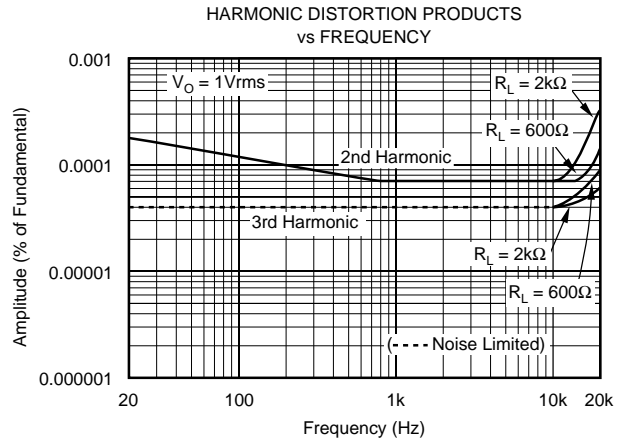
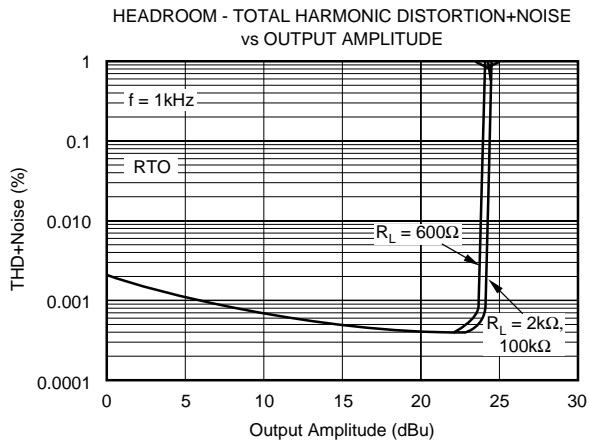
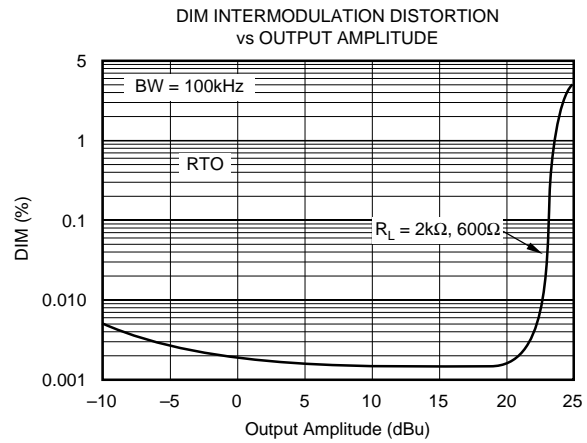
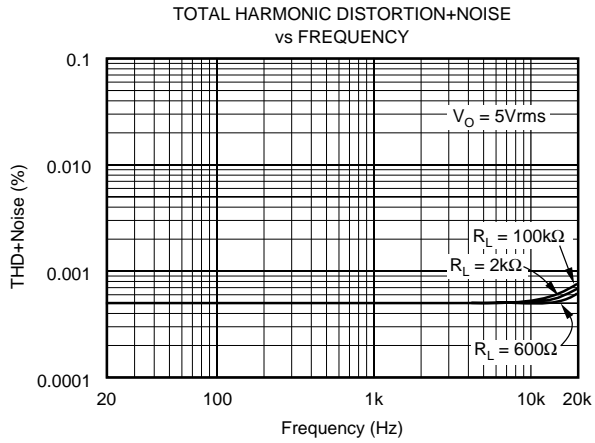

TYPICAL PERFORMANCE CURVES (CONT)

At $T_A = +25^\circ\text{C}$, $V_S = \pm 18\text{V}$, and $G = 1/2$, unless otherwise noted.

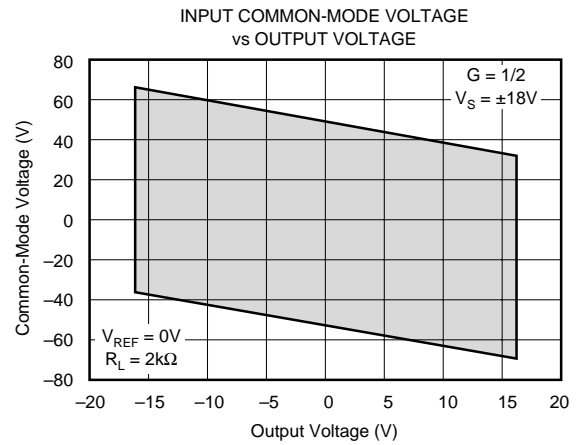
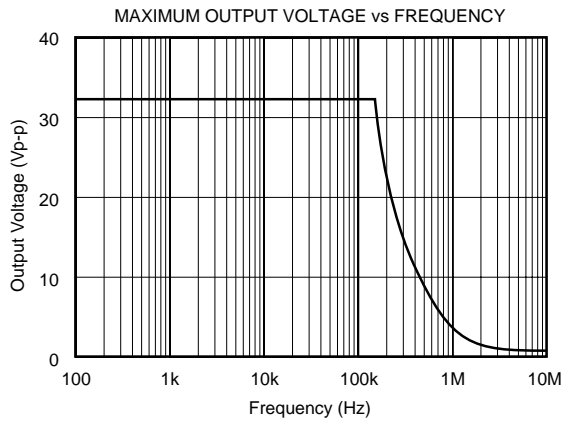
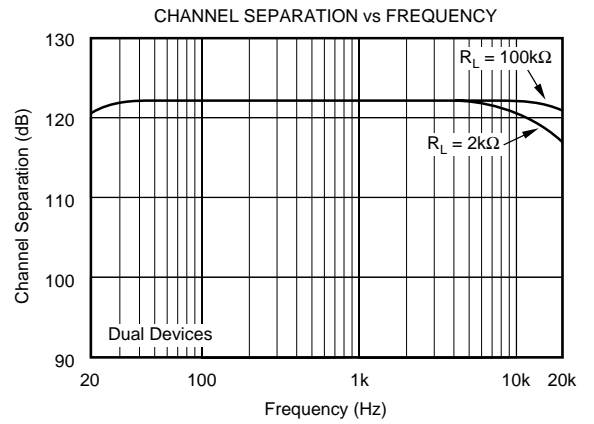
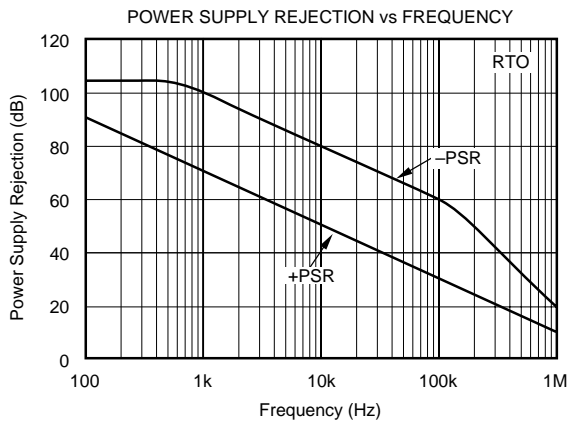
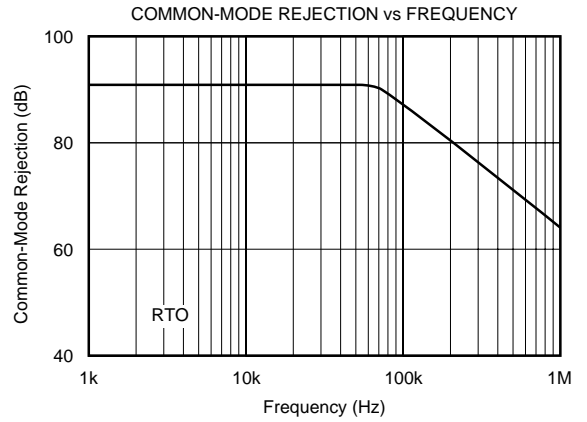
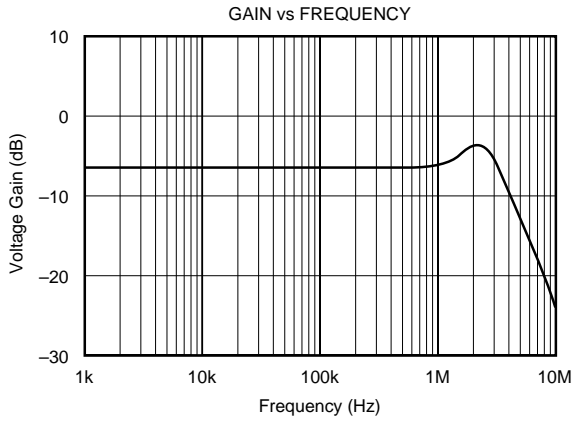

TYPICAL PERFORMANCE CURVES (CONT)

At $T_A = +25^\circ\text{C}$, $V_S = \pm 18\text{V}$, and $G = 1/2$, unless otherwise noted.

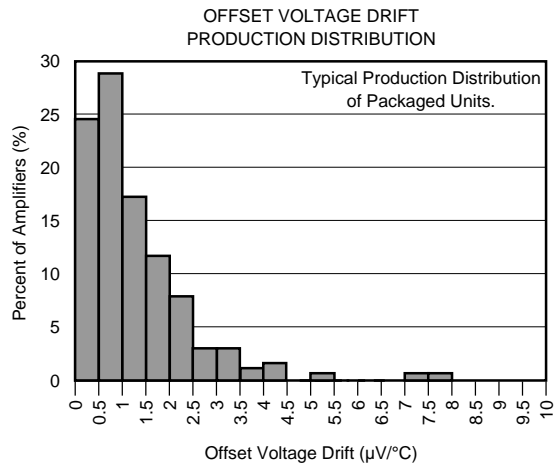
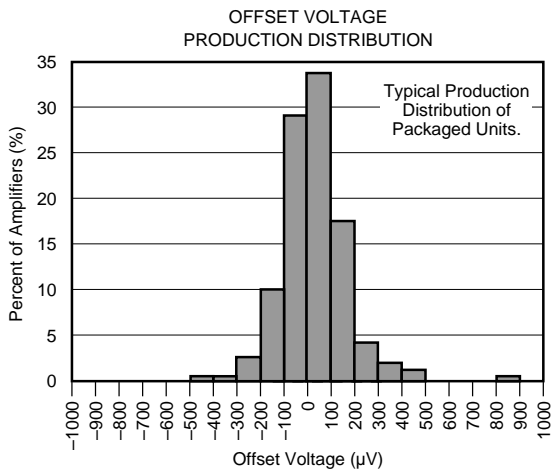
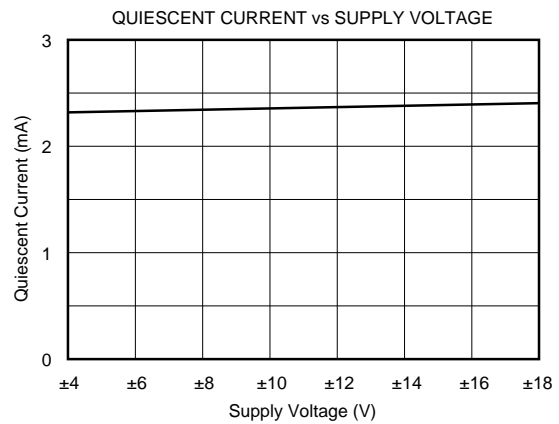
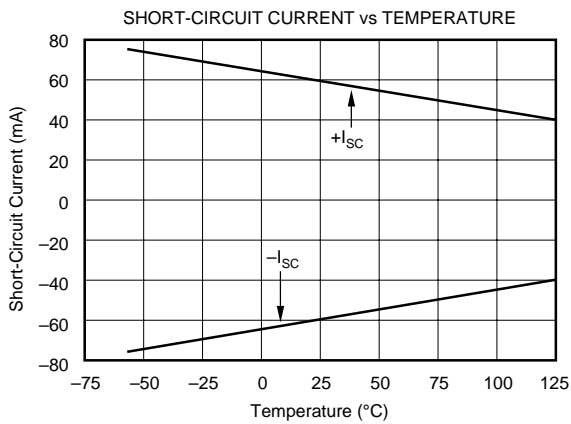
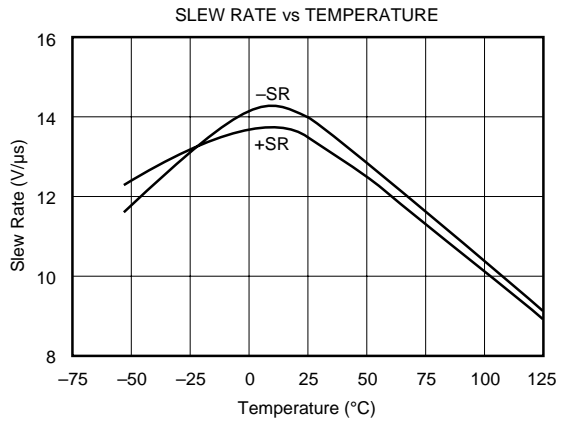
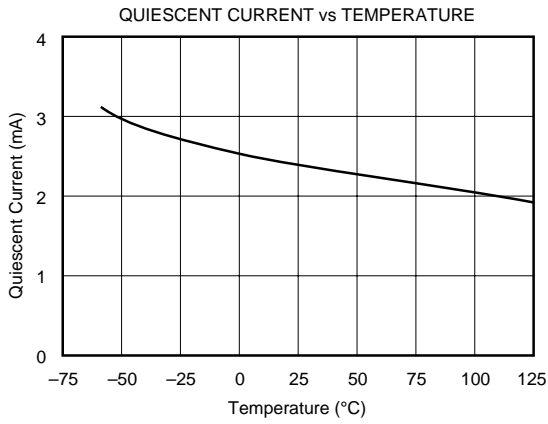

TYPICAL PERFORMANCE CURVES (CONT)

At $T_A = +25^\circ\text{C}$, $V_S = \pm 18\text{V}$, and $G = 1/2$, unless otherwise noted.

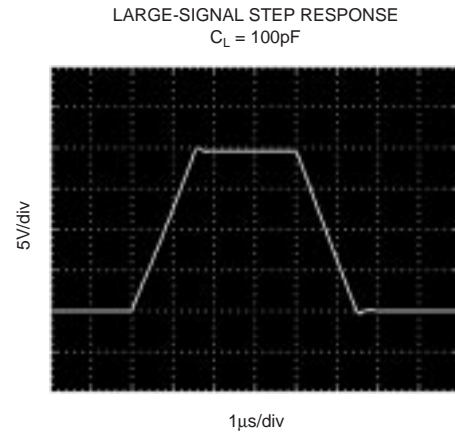
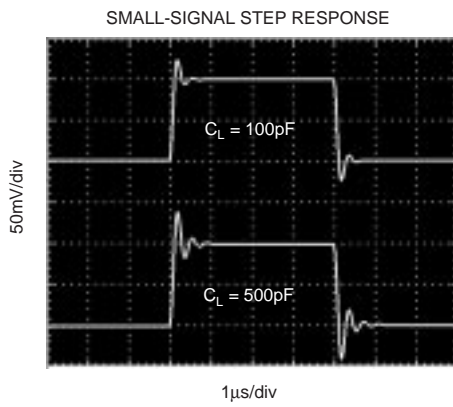
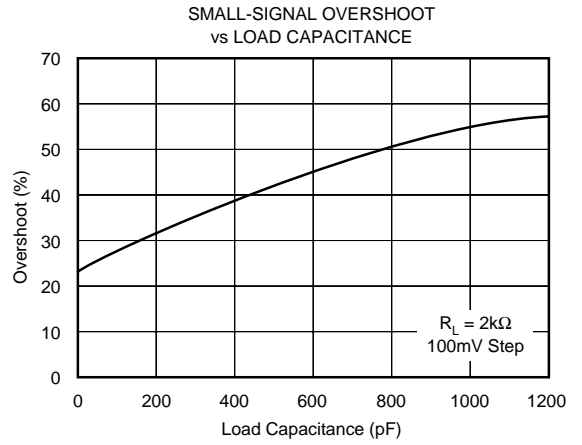
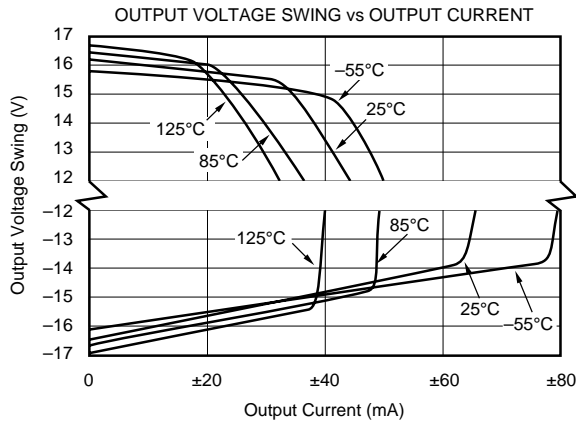

APPLICATIONS INFORMATION

The INA137 and INA2137 are differential line receivers suitable for a wide range of audio and general-purpose applications. Figure 1 shows the basic $G = 1/2$ (-6dB) differential receiver configuration. The input and feedback resistors can be reversed to achieve $G = 2$ ($+6\text{dB}$), as shown in Figure 2. For applications requiring $G = 1$ (0dB), the INA134 and INA2134 are recommended.

Decoupling capacitors are strongly recommended for applications with noisy or high impedance power supplies. The capacitors should be placed close to the device pins as shown in Figure 1. All circuitry is completely independent in the dual version assuring lowest crosstalk and normal behavior when one amplifier is overdriven or short-circuited.

As shown in Figure 1, the differential input signal is connected to pins 2 and 3. The source impedances connected to the inputs must be nearly equal to assure good common-mode rejection. A 5Ω mismatch in source impedance will degrade the common-mode rejection of a typical device to approximately 77dB (RTO). If the source has a known impedance mismatch, an additional resistor in series with the opposite input can be used to preserve good common-mode rejection.

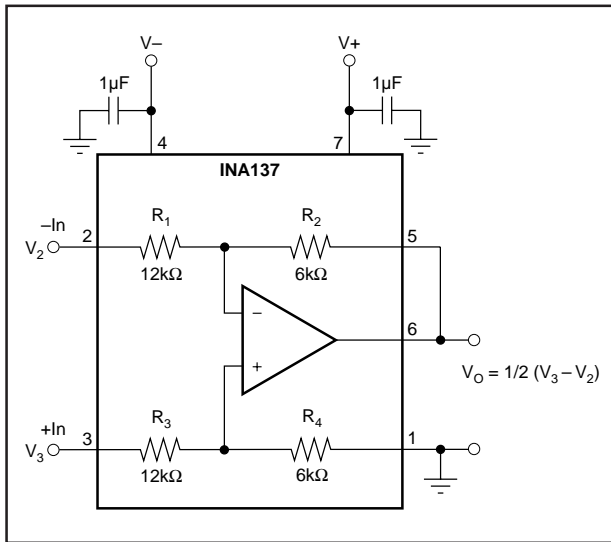

FIGURE 1. $G = 1/2$ Differential Receiver (Basic Power Supply and Signal Connections).

AUDIO PERFORMANCE

The INA137 and INA2137 were designed for enhanced ac performance. Very low distortion, low noise, and wide bandwidth provide superior performance in high quality audio applications. Laser-trimmed matched resistors provide optimum common-mode rejection (typically 90dB), especially when compared to circuits implemented with an op amp and discrete precision resistors. In addition, high slew rate ($14\text{V}/\mu\text{s}$) and fast settling time ($3\mu\text{s}$ to 0.01%) ensure excellent dynamic performance.

The INA137 and INA2137 have excellent distortion characteristics. $\text{THD} + \text{Noise}$ is below 0.001% throughout the audio frequency range. Up to approximately 10kHz distortion is below the measurement limit of commonly used test equipment. Furthermore, distortion remains relatively flat over its wide output voltage swing range (approximately 1.7V from either supply).

OFFSET VOLTAGE TRIM

The INA137 and INA2137 are laser trimmed for low offset voltage and drift. Most applications require no external offset adjustment. Figure 3 shows an optional circuit for trimming the output offset voltage. The output is referred to the output reference terminal (pin 1), which is normally grounded. A voltage applied to the Ref terminal will be summed with the output signal. This can be used to null offset voltage as shown in Figure 3. The source impedance of a signal applied to the Ref terminal should be less than 10Ω to maintain good common-mode rejection.

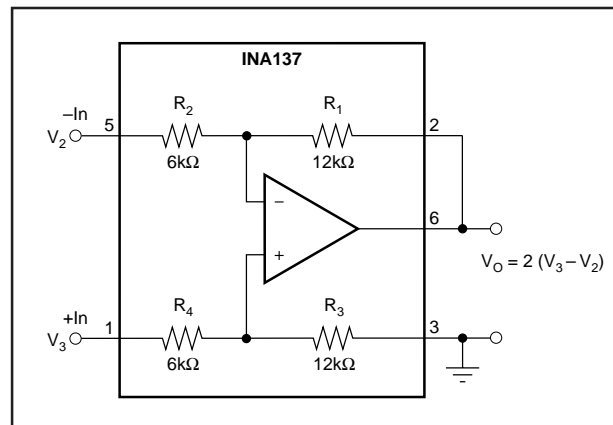

FIGURE 2. $G = 2$ Differential Receiver.

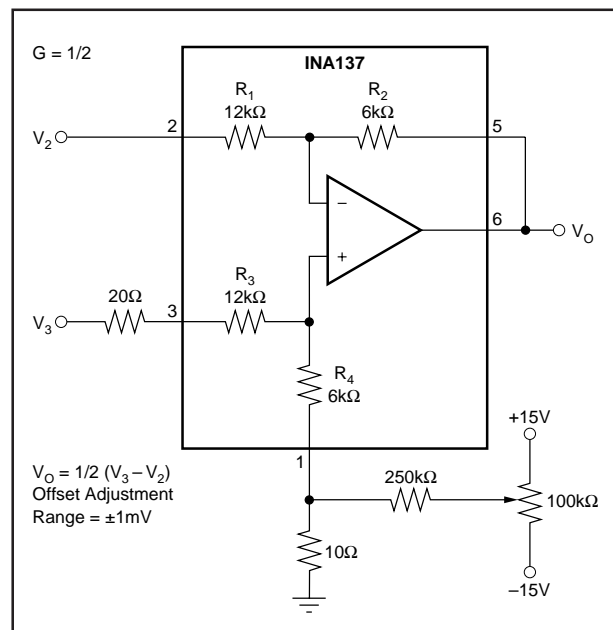

FIGURE 3. Offset Adjustment.

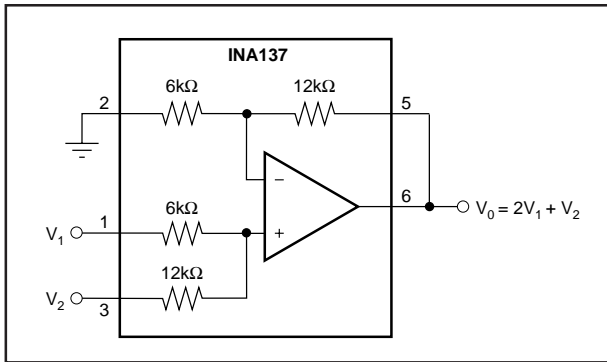

FIGURE 4. Precision Summing Amplifier.

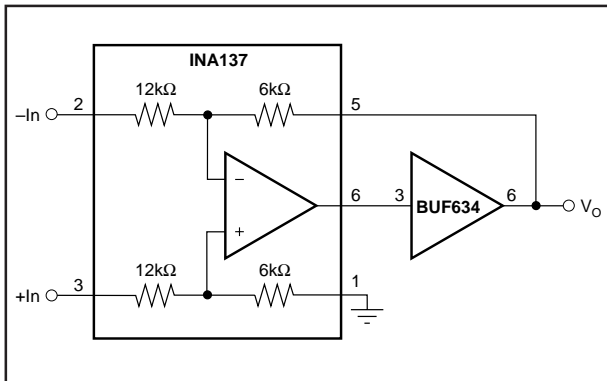

FIGURE 5. Boosting Output Current.

The difference amplifier is a highly versatile building block that is useful in a wide variety of applications. See the INA105 data sheet for additional applications ideas, including:

- Current Receiver with Compliance to Rails
- $\pm 10\text{V}$ Precision Voltage Reference
- $\pm 5\text{V}$ Precision Voltage Reference
- Precision Average Value Amplifier
- Precision Bipolar Offsetting
- Precision Summing Amplifier with Gain
- Instrumentation Amplifier Guard Drive Generator
- Precision Summing Instrumentation Amplifier
- Precision Absolute Value Buffer

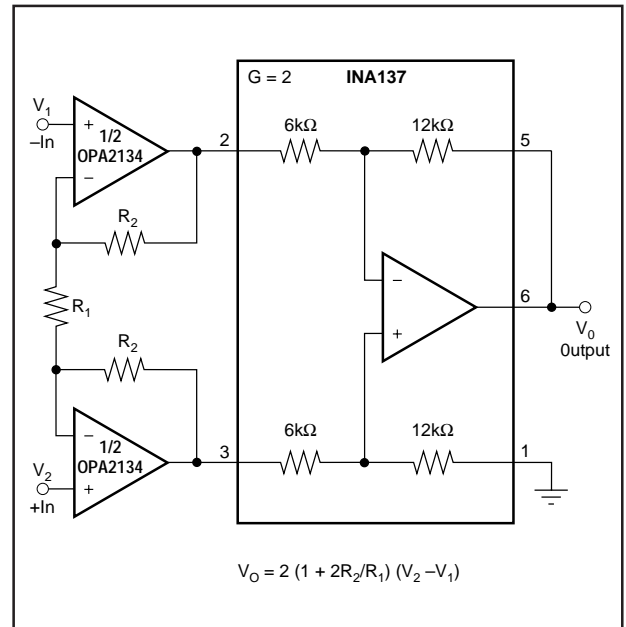

FIGURE 6. High Input Impedance Instrumentation Amplifier.

- Precision Voltage-to-Current Converter with Differential Inputs
- Differential Input Voltage-to-Current Converter for Low I_{OUT}
- Isolating Current Source
- Differential Output Difference Amplifier
- Isolating Current Source with Buffering Amplifier for Greater Accuracy
- Window Comparator with Window Span and Window Center Inputs
- Precision Voltage-Controlled Current Source with Buffered Differential Inputs and Gain

PACKAGING INFORMATION

Orderable Device	Status ⁽¹⁾	Package Type	Package Drawing	Pins	Package Qty	Eco Plan ⁽²⁾	Lead/Ball Finish	MSL Peak Temp ⁽³⁾
INA137PA	ACTIVE	PDIP	P	8	50	Green (RoHS & no Sb/Br)	CU NIPDAU	N / A for Pkg Type
INA137PAG4	ACTIVE	PDIP	P	8	50	Green (RoHS & no Sb/Br)	CU NIPDAU	N / A for Pkg Type
INA137UA	ACTIVE	SOIC	D	8	75	Green (RoHS & no Sb/Br)	CU NIPDAU	Level-3-260C-168 HR
INA137UA/2K5	ACTIVE	SOIC	D	8	2500	Green (RoHS & no Sb/Br)	CU NIPDAU	Level-3-260C-168 HR
INA137UA/2K5G4	ACTIVE	SOIC	D	8	2500	Green (RoHS & no Sb/Br)	CU NIPDAU	Level-3-260C-168 HR
INA137UAG4	ACTIVE	SOIC	D	8	75	Green (RoHS & no Sb/Br)	CU NIPDAU	Level-3-260C-168 HR
INA2137PA	ACTIVE	PDIP	N	14	25	Green (RoHS & no Sb/Br)	CU NIPDAU	N / A for Pkg Type
INA2137PAG4	ACTIVE	PDIP	N	14	25	Green (RoHS & no Sb/Br)	CU NIPDAU	N / A for Pkg Type
INA2137UA	ACTIVE	SOIC	D	14	50	Green (RoHS & no Sb/Br)	CU NIPDAU	Level-3-260C-168 HR
INA2137UA/2K5	ACTIVE	SOIC	D	14	2500	Green (RoHS & no Sb/Br)	CU NIPDAU	Level-3-260C-168 HR
INA2137UA/2K5E4	ACTIVE	SOIC	D	14	2500	Green (RoHS & no Sb/Br)	CU NIPDAU	Level-3-260C-168 HR
INA2137UAE4	ACTIVE	SOIC	D	14	50	Green (RoHS & no Sb/Br)	CU NIPDAU	Level-3-260C-168 HR

⁽¹⁾ The marketing status values are defined as follows:

ACTIVE: Product device recommended for new designs.

LIFEBUY: TI has announced that the device will be discontinued, and a lifetime-buy period is in effect.

NRND: Not recommended for new designs. Device is in production to support existing customers, but TI does not recommend using this part in a new design.

PREVIEW: Device has been announced but is not in production. Samples may or may not be available.

OBSOLETE: TI has discontinued the production of the device.

⁽²⁾ Eco Plan - The planned eco-friendly classification: Pb-Free (RoHS), Pb-Free (RoHS Exempt), or Green (RoHS & no Sb/Br) - please check <http://www.ti.com/productcontent> for the latest availability information and additional product content details.

TBD: The Pb-Free/Green conversion plan has not been defined.

Pb-Free (RoHS): TI's terms "Lead-Free" or "Pb-Free" mean semiconductor products that are compatible with the current RoHS requirements for all 6 substances, including the requirement that lead not exceed 0.1% by weight in homogeneous materials. Where designed to be soldered at high temperatures, TI Pb-Free products are suitable for use in specified lead-free processes.

Pb-Free (RoHS Exempt): This component has a RoHS exemption for either 1) lead-based flip-chip solder bumps used between the die and package, or 2) lead-based die adhesive used between the die and leadframe. The component is otherwise considered Pb-Free (RoHS compatible) as defined above.

Green (RoHS & no Sb/Br): TI defines "Green" to mean Pb-Free (RoHS compatible), and free of Bromine (Br) and Antimony (Sb) based flame retardants (Br or Sb do not exceed 0.1% by weight in homogeneous material)

⁽³⁾ MSL, Peak Temp. -- The Moisture Sensitivity Level rating according to the JEDEC industry standard classifications, and peak solder temperature.

Important Information and Disclaimer: The information provided on this page represents TI's knowledge and belief as of the date that it is provided. TI bases its knowledge and belief on information provided by third parties, and makes no representation or warranty as to the accuracy of such information. Efforts are underway to better integrate information from third parties. TI has taken and continues to take reasonable steps to provide representative and accurate information but may not have conducted destructive testing or chemical analysis on incoming materials and chemicals. TI and TI suppliers consider certain information to be proprietary, and thus CAS numbers and other limited information may not be available for release.

In no event shall TI's liability arising out of such information exceed the total purchase price of the TI part(s) at issue in this document sold by TI to Customer on an annual basis.

TAPE AND REEL INFORMATION



QUADRANT ASSIGNMENTS FOR PIN 1 ORIENTATION IN TAPE

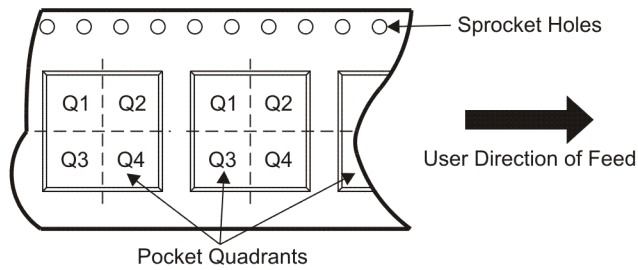

*All dimensions are nominal

Device	Package Type	Package Drawing	Pins	SPQ	Reel Diameter (mm)	Reel Width W1 (mm)	A0 (mm)	B0 (mm)	K0 (mm)	P1 (mm)	W (mm)	Pin1 Quadrant
INA137UA/2K5	SOIC	D	8	2500	330.0	12.4	6.4	5.2	2.1	8.0	12.0	Q1
INA2137UA/2K5	SOIC	D	14	2500	330.0	16.4	6.5	9.0	2.1	8.0	16.0	Q1

TAPE AND REEL BOX DIMENSIONS



*All dimensions are nominal

Device	Package Type	Package Drawing	Pins	SPQ	Length (mm)	Width (mm)	Height (mm)
INA137UA/2K5	SOIC	D	8	2500	346.0	346.0	29.0
INA2137UA/2K5	SOIC	D	14	2500	346.0	346.0	33.0

IMPORTANT NOTICE

Texas Instruments Incorporated and its subsidiaries (TI) reserve the right to make corrections, modifications, enhancements, improvements, and other changes to its products and services at any time and to discontinue any product or service without notice. Customers should obtain the latest relevant information before placing orders and should verify that such information is current and complete. All products are sold subject to TI's terms and conditions of sale supplied at the time of order acknowledgment.

TI warrants performance of its hardware products to the specifications applicable at the time of sale in accordance with TI's standard warranty. Testing and other quality control techniques are used to the extent TI deems necessary to support this warranty. Except where mandated by government requirements, testing of all parameters of each product is not necessarily performed.

TI assumes no liability for applications assistance or customer product design. Customers are responsible for their products and applications using TI components. To minimize the risks associated with customer products and applications, customers should provide adequate design and operating safeguards.

TI does not warrant or represent that any license, either express or implied, is granted under any TI patent right, copyright, mask work right, or other TI intellectual property right relating to any combination, machine, or process in which TI products or services are used. Information published by TI regarding third-party products or services does not constitute a license from TI to use such products or services or a warranty or endorsement thereof. Use of such information may require a license from a third party under the patents or other intellectual property of the third party, or a license from TI under the patents or other intellectual property of TI.

Reproduction of TI information in TI data books or data sheets is permissible only if reproduction is without alteration and is accompanied by all associated warranties, conditions, limitations, and notices. Reproduction of this information with alteration is an unfair and deceptive business practice. TI is not responsible or liable for such altered documentation. Information of third parties may be subject to additional restrictions.

Resale of TI products or services with statements different from or beyond the parameters stated by TI for that product or service voids all express and any implied warranties for the associated TI product or service and is an unfair and deceptive business practice. TI is not responsible or liable for any such statements.

TI products are not authorized for use in safety-critical applications (such as life support) where a failure of the TI product would reasonably be expected to cause severe personal injury or death, unless officers of the parties have executed an agreement specifically governing such use. Buyers represent that they have all necessary expertise in the safety and regulatory ramifications of their applications, and acknowledge and agree that they are solely responsible for all legal, regulatory and safety-related requirements concerning their products and any use of TI products in such safety-critical applications, notwithstanding any applications-related information or support that may be provided by TI. Further, Buyers must fully indemnify TI and its representatives against any damages arising out of the use of TI products in such safety-critical applications.

TI products are neither designed nor intended for use in military/aerospace applications or environments unless the TI products are specifically designated by TI as military-grade or "enhanced plastic." Only products designated by TI as military-grade meet military specifications. Buyers acknowledge and agree that any such use of TI products which TI has not designated as military-grade is solely at the Buyer's risk, and that they are solely responsible for compliance with all legal and regulatory requirements in connection with such use.

TI products are neither designed nor intended for use in automotive applications or environments unless the specific TI products are designated by TI as compliant with ISO/TS 16949 requirements. Buyers acknowledge and agree that, if they use any non-designated products in automotive applications, TI will not be responsible for any failure to meet such requirements.

Following are URLs where you can obtain information on other Texas Instruments products and application solutions:

Products

Amplifiers	amplifier.ti.com
Data Converters	dataconverter.ti.com
DLP® Products	www.dlp.com
DSP	dsp.ti.com
Clocks and Timers	www.ti.com/clocks
Interface	interface.ti.com
Logic	logic.ti.com
Power Mgmt	power.ti.com
Microcontrollers	microcontroller.ti.com
RFID	www.ti-rfid.com
RF/IF and ZigBee® Solutions	www.ti.com/lprf

Applications

Audio	www.ti.com/audio
Automotive	www.ti.com/automotive
Broadband	www.ti.com/broadband
Digital Control	www.ti.com/digitalcontrol
Medical	www.ti.com/medical
Military	www.ti.com/military
Optical Networking	www.ti.com/opticalnetwork
Security	www.ti.com/security
Telephony	www.ti.com/telephony
Video & Imaging	www.ti.com/video
Wireless	www.ti.com/wireless

Mailing Address: Texas Instruments, Post Office Box 655303, Dallas, Texas 75265
Copyright © 2009, Texas Instruments Incorporated

Looking for pricing, stock, or lifecycle information?

Click below to explore more details on WIN SOURCE:

 [View INA137UA/2K5 on WIN SOURCE](#)

 [Texas Instruments](#) Information

Optimize Your Supply Chain with WIN SOURCE Solutions

-  Global Sourcing Solution
-  Obsolete Management
-  Cost Control Management
-  Shortage Management
-  Alternative Solution
-  Excess Inventory Management