



**THE DATASHEET OF  
MC100E446FNG**



# MC10E446, MC100E446

## 5V ECL 4-Bit Parallel/Serial Converter

### Description

The MC10E/100E446 is an integrated 4-bit parallel to serial data converter. The device is designed to operate for NRZ data rates of up to 1.3 Gb/s. The chip generates a divide by 4 and a divide by 8 clock for both 4-bit conversion and a two chip 8-bit conversion function. The conversion sequence was chosen to convert the parallel data into a serial stream from bit D0 to D3. A serial input is provided to cascade two E446 devices for 8 bit conversion applications. Note that the serial output data clocks off of the negative input clock transition.

The SYNC input will asynchronously reset the internal clock circuitry. This pin allows the user to reset the internal clock conversion unit and thus select the start of the conversion process.

The MODE input is used to select the conversion mode of the device. With the MODE input LOW, or open, the device will function as a 4-bit converter. When the mode input is driven HIGH the internal load clock will change on every eighth clock cycle thus allowing for an 8-bit conversion scheme using two E446's. When cascaded in an 8-bit conversion scheme the devices will not operate at the 1.3 Gb/s data rate of a single device. Refer to the applications section of this data sheet for more information on cascading the E446.

The  $V_{BB}$  pin, an internally generated voltage supply, is available to this device only. For single-ended input conditions, the unused differential input is connected to  $V_{BB}$  as a switching reference voltage.  $V_{BB}$  may also rebias AC coupled inputs. When used, decouple  $V_{BB}$  and  $V_{CC}$  via a 0.01  $\mu$ F capacitor and limit current sourcing or sinking to 0.5 mA. When not used,  $V_{BB}$  should be left open.

The 100 Series contains temperature compensation.

### Features

- On Chip Clock  $\div 4$  and  $\div 8$
- 1.5 Gb/s Typical Data Rate Capability
- Differential Clock and Serial Inputs
- $V_{BB}$  Output for Single-ended Input Applications
- Asynchronous Data Synchronization
- Mode Select to Expand to 8 Bits
- PECL Mode Operating Range:  $V_{CC} = 4.2$  V to 5.7 V with  $V_{EE} = 0$  V
- NECL Mode Operating Range:  $V_{CC} = 0$  V with  $V_{EE} = -4.2$  V to  $-5.7$  V
- Internal Input 50 k $\Omega$  Pulldown Resistors
- ESD Protection: Human Body Model; > 2 kV, Machine Model; > 100 V

\*For additional information on our Pb-Free strategy and soldering details, please download the ON Semiconductor Soldering and Mounting Techniques Reference Manual, SOLDERRM/D.



ON Semiconductor®

<http://onsemi.com>

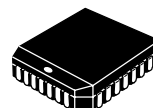

PLCC-28  
FN SUFFIX  
CASE 776

### MARKING DIAGRAM\*

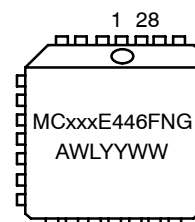

xxx	= 10 or 100
A	= Assembly Location
WL	= Wafer Lot
YY	= Year
WW	= Work Week
G	= Pb-Free Package

\*For additional marking information, refer to Application Note AND8002/D.

### ORDERING INFORMATION

See detailed ordering and shipping information in the package dimensions section on page 10 of this data sheet.

- Meets or Exceeds JEDEC Spec EIA/JESD78 IC Latchup Test
- Flammability Rating: UL 94 V-0 @ 0.125 in, Oxygen Index: 28 to 34
- Transistor Count = 525 devices
- Moisture Sensitivity Level: Pb = 1; Pb-Free = 3 For Additional Information, see Application Note AND8003/D
- Pb-Free Packages are Available\*

# MC10E446, MC100E446

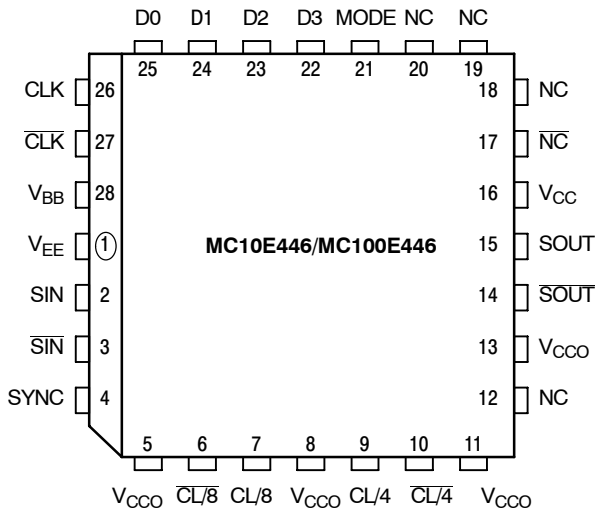

\* All V<sub>CC</sub> and V<sub>CCO</sub> pins are tied together on the die.

Warning: All V<sub>CC</sub>, V<sub>CCO</sub>, and V<sub>EE</sub> pins must be externally connected to Power Supply to guarantee proper operation.

**Figure 1. Pinout: PLCC-28 (Top View)**

**Table 1. PIN DESCRIPTION**

PIN	FUNCTION
SIN	ECL Differential Serial Data Input
D0 - D3	ECL Parallel Data Inputs
SOUT, SOUT	ECL Differential Serial Data Output
CLK, CLK	ECL Differential Clock Inputs
CL/4, CL/4	ECL Differential ±4 Clock Output
CL/8, CL/8	ECL Differential ±8 Clock Output
MODE	Conversion Mode 4-Bit/8-Bit
SYNC	ECL Conversion Synchronizing Input
V <sub>BB</sub>	Reference Voltage Output
V <sub>CC</sub> , V <sub>CCO</sub>	Positive Supply
V <sub>EE</sub>	Negative Supply
NC	No Connect

# MC10E446, MC100E446

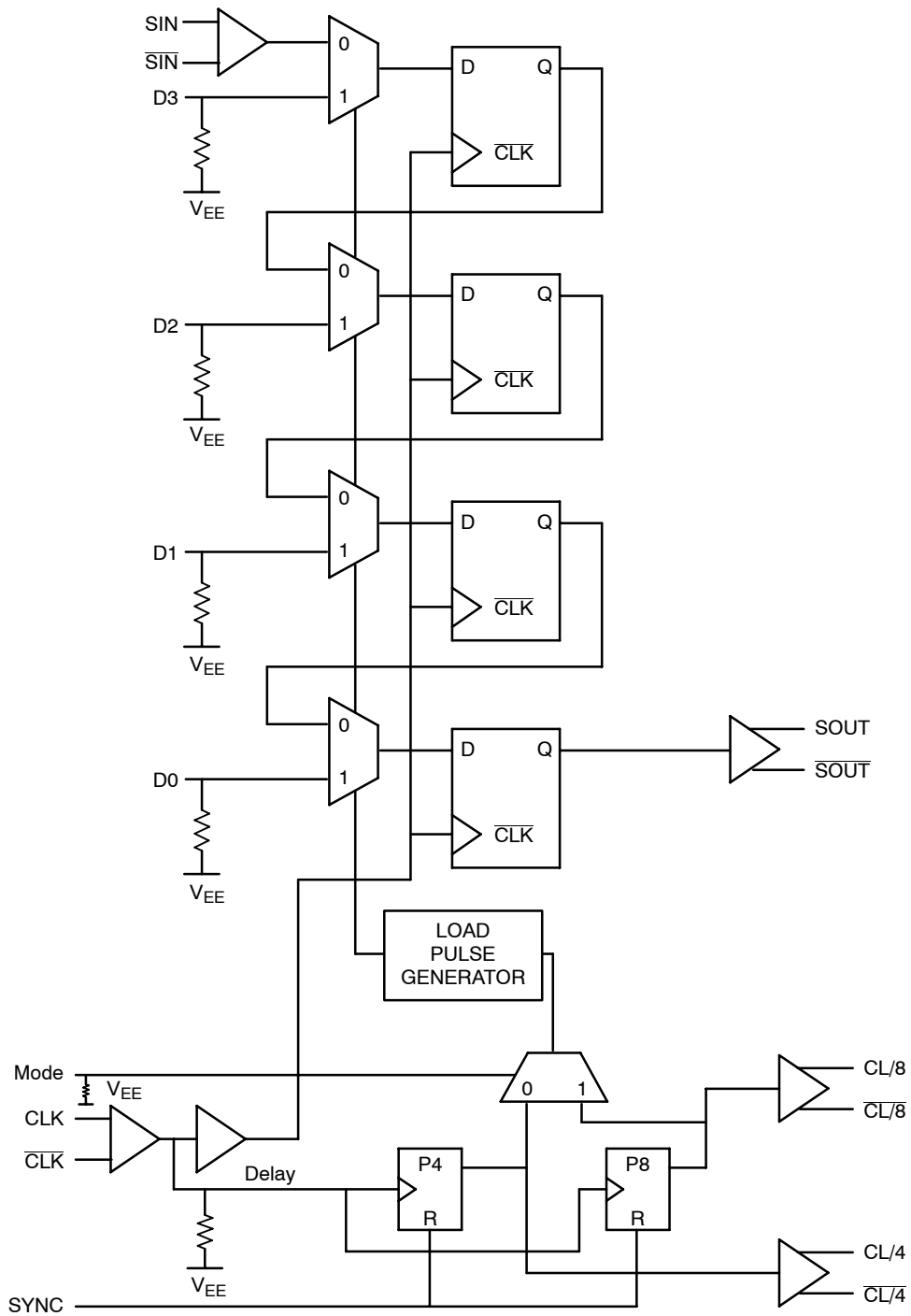

Figure 2. Logic Diagram

Table 2. FUNCTION TABLES

Mode	Conversion
L	4-Bit
H	8-Bit

# MC10E446, MC100E446

**Table 3. MAXIMUM RATINGS**

Symbol	Parameter	Condition 1	Condition 2	Rating	Unit
$V_{CC}$	PECL Mode Power Supply	$V_{EE} = 0\text{ V}$		8	V
$V_I$	PECL Mode Input Voltage NECL Mode Input Voltage	$V_{EE} = 0\text{ V}$ $V_{CC} = 0\text{ V}$	$V_I \leq V_{CC}$ $V_I \geq V_{EE}$	6 -6	V V
$I_{out}$	Output Current	Continuous Surge		50 100	mA mA
$I_{BB}$	$V_{BB}$ Sink/Source			$\pm 0.5$	mA
$T_A$	Operating Temperature Range			0 to +85	$^{\circ}\text{C}$
$T_{stg}$	Storage Temperature Range			-65 to +150	$^{\circ}\text{C}$
$\theta_{JA}$	Thermal Resistance (Junction-to-Ambient)	0 lfpm 500 lfpm	PLCC-28 PLCC-28	63.5 43.5	$^{\circ}\text{C}/\text{W}$ $^{\circ}\text{C}/\text{W}$
$\theta_{JC}$	Thermal Resistance (Junction-to-Case)	Standard Board	PLCC-28	22 to 26	$^{\circ}\text{C}/\text{W}$
$T_{sol}$	Wave Solder Pb Pb-Free			265 265	$^{\circ}\text{C}$

Stresses exceeding Maximum Ratings may damage the device. Maximum Ratings are stress ratings only. Functional operation above the Recommended Operating Conditions is not implied. Extended exposure to stresses above the Recommended Operating Conditions may affect device reliability.

# MC10E446, MC100E446

**Table 4. 10E SERIES PECL DC CHARACTERISTICS**  $V_{CCx} = 5.0\text{ V}$ ;  $V_{EE} = 0.0\text{ V}$  (Note 1)

Symbol	Characteristic	0°C			25°C			85°C			Unit
		Min	Typ	Max	Min	Typ	Max	Min	Typ	Max	
$I_{EE}$	Power Supply Current		126	151		126	151		126	151	mA
$V_{OH}$	Output HIGH Voltage (Note 2)	3980	4070	4160	4020	4105	4190	4090	4185	4280	mV
$VOH_{SOUT}$	Output HIGH Voltage SOUT/SOUT	3980		4210	4020		4240	4090		4330	mV
$V_{OL}$	Output LOW Voltage (Note 2)	3050	3210	3370	3050	3210	3370	3050	3227	3405	mV
$V_{IH}$	Input HIGH Voltage	3830	3995	4160	3870	4030	4190	3940	4110	4280	mV
$V_{IL}$	Input LOW Voltage	3050	3285	3520	3050	3285	3520	3050	3302	3555	mV
$V_{BB}$	Output Voltage Reference	3.62		3.74	3.65		3.75	3.69		3.81	V
$I_{IH}$	Input HIGH Current			150			150			150	$\mu\text{A}$
$I_{IL}$	Input LOW Current	0.5	0.3		0.5	0.25		0.3	0.2		$\mu\text{A}$

NOTE: Device will meet the specifications after thermal equilibrium has been established when mounted in a test socket or printed circuit board with maintained transverse airflow greater than 500 lfm. Electrical parameters are guaranteed only over the declared operating temperature range. Functional operation of the device exceeding these conditions is not implied. Device specification limit values are applied individually under normal operating conditions and not valid simultaneously.

1. Input and output parameters vary 1:1 with  $V_{CC}$ .  $V_{EE}$  can vary  $-0.46\text{ V} / +0.06\text{ V}$ .
2. Outputs are terminated through a  $50\ \Omega$  resistor to  $V_{CC} - 2.0\text{ V}$ .

**Table 5. 10E SERIES NECL DC CHARACTERISTICS**  $V_{CCx} = 0.0\text{ V}$ ;  $V_{EE} = -5.0\text{ V}$  (Note 3)

Symbol	Characteristic	0°C			25°C			85°C			Unit
		Min	Typ	Max	Min	Typ	Max	Min	Typ	Max	
$I_{EE}$	Power Supply Current		126	151		126	151		126	151	mA
$V_{OH}$	Output HIGH Voltage (Note 4)	-1020	-930	-840	-980	-895	-810	-910	-815	-720	mV
$VOH_{SOUT}$	Output HIGH Voltage SOUT/SOUT	-1020		-790	-980		-760	-910		-670	mV
$V_{OL}$	Output LOW Voltage (Note 4)	-1950	-1790	-1630	-1950	-1790	-1630	-1950	-1773	-1595	mV
$V_{IH}$	Input HIGH Voltage	-1170	-1005	-840	-1130	-970	-810	-1060	-890	-720	mV
$V_{IL}$	Input LOW Voltage	-1950	-1715	-1480	-1950	-1715	-1480	-1950	-1698	-1445	mV
$V_{BB}$	Output Voltage Reference	-1.38		-1.27	-1.35		-1.25	-1.31		-1.19	V
$I_{IH}$	Input HIGH Current			150			150			150	$\mu\text{A}$
$I_{IL}$	Input LOW Current	0.5	0.3		0.5	0.065		0.3	0.2		$\mu\text{A}$

NOTE: Device will meet the specifications after thermal equilibrium has been established when mounted in a test socket or printed circuit board with maintained transverse airflow greater than 500 lfm. Electrical parameters are guaranteed only over the declared operating temperature range. Functional operation of the device exceeding these conditions is not implied. Device specification limit values are applied individually under normal operating conditions and not valid simultaneously.

3. Input and output parameters vary 1:1 with  $V_{CC}$ .  $V_{EE}$  can vary  $-0.46\text{ V} / +0.06\text{ V}$ .
4. Outputs are terminated through a  $50\ \Omega$  resistor to  $V_{CC} - 2.0\text{ V}$ .

# MC10E446, MC100E446

**Table 6. 100E SERIES PECL DC CHARACTERISTICS**  $V_{CCx} = 5.0\text{ V}$ ;  $V_{EE} = 0.0\text{ V}$  (Note 5)

Symbol	Characteristic	0°C			25°C			85°C			Unit
		Min	Typ	Max	Min	Typ	Max	Min	Typ	Max	
$I_{EE}$	Power Supply Current		126	151		126	151		145	174	mA
$V_{OH}$	Output HIGH Voltage (Note 6)	3975	4050	4120	3975	4050	4120	3975	4050	4120	mV
$VOH_{SOUT}$	Output HIGH Voltage SOUT/SOUT	3975		4170	3975		4170	3975		4170	mV
$V_{OL}$	Output LOW Voltage (Note 6)	3190	3295	3380	3190	3255	3380	3190	3260	3380	mV
$V_{IH}$	Input HIGH Voltage	3835	3975	4120	3835	3975	4120	3835	3975	4120	mV
$V_{IL}$	Input LOW Voltage	3190	3355	3525	3190	3355	3525	3190	3355	3525	mV
$V_{BB}$	Output Voltage Reference	3.62		3.73	3.62		3.74	3.62		3.74	V
$I_{IH}$	Input HIGH Current			150			150			150	$\mu\text{A}$
$I_{IL}$	Input LOW Current	0.5	0.3		0.5	0.25		0.5	0.2		$\mu\text{A}$

NOTE: Device will meet the specifications after thermal equilibrium has been established when mounted in a test socket or printed circuit board with maintained transverse airflow greater than 500 lfm. Electrical parameters are guaranteed only over the declared operating temperature range. Functional operation of the device exceeding these conditions is not implied. Device specification limit values are applied individually under normal operating conditions and not valid simultaneously.

5. Input and output parameters vary 1:1 with  $V_{CC}$ .  $V_{EE}$  can vary  $-0.46\text{ V} / +0.8\text{ V}$ .

6. Outputs are terminated through a  $50\ \Omega$  resistor to  $V_{CC} - 2.0\text{ V}$ .

**Table 7. 100E SERIES NECL DC CHARACTERISTICS**  $V_{CCx} = 0.0\text{ V}$ ;  $V_{EE} = -5.0\text{ V}$  (Note 7)

Symbol	Characteristic	0°C			25°C			85°C			Unit
		Min	Typ	Max	Min	Typ	Max	Min	Typ	Max	
$I_{EE}$	Power Supply Current		126	151		126	151		145	174	mA
$V_{OH}$	Output HIGH Voltage (Note 8)	-1025	-950	-880	-1025	-950	-880	-1025	-950	-880	mV
$VOH_{SOUT}$	Output HIGH Voltage SOUT/SOUT	-1025		-830	-1025		-830	-1025		-830	mV
$V_{OL}$	Output LOW Voltage (Note 8)	-1810	-1705	-1620	-1810	-1745	-1620	-1810	-1740	-1620	mV
$V_{IH}$	Input HIGH Voltage	-1165	-1025	-880	-1165	-1025	-880	-1165	-1025	-880	mV
$V_{IL}$	Input LOW Voltage	-1810	-1645	-1475	-1810	-1645	-1475	-1810	-1645	-1475	mV
$V_{BB}$	Output Voltage Reference	-1.38		-1.27	-1.38		-1.26	-1.38		-1.26	V
$I_{IH}$	Input HIGH Current			150			150			150	$\mu\text{A}$
$I_{IL}$	Input LOW Current	0.5	0.3		0.5	0.25		0.5	0.2		$\mu\text{A}$

NOTE: Device will meet the specifications after thermal equilibrium has been established when mounted in a test socket or printed circuit board with maintained transverse airflow greater than 500 lfm. Electrical parameters are guaranteed only over the declared operating temperature range. Functional operation of the device exceeding these conditions is not implied. Device specification limit values are applied individually under normal operating conditions and not valid simultaneously.

7. Input and output parameters vary 1:1 with  $V_{CC}$ .  $V_{EE}$  can vary  $-0.46\text{ V} / +0.8\text{ V}$ .

8. Outputs are terminated through a  $50\ \Omega$  resistor to  $V_{CC} - 2.0\text{ V}$ .

# MC10E446, MC100E446

**Table 8. AC CHARACTERISTICS**  $V_{CCx} = 5.0\text{ V}$ ;  $V_{EE} = 0.0\text{ V}$  or  $V_{CCx} = 0.0\text{ V}$ ;  $V_{EE} = -5.0\text{ V}$  (Note 9)

Symbol	Characteristic	0°C			25°C			85°C			Unit
		Min	Typ	Max	Min	Typ	Max	Min	Typ	Max	
$F_{MAX}$	Max Conversion Frequency	1.3	1.6		1.3	1.6		1.3	1.6		Gb/s NRZ
$t_{PLH}$ $t_{PHL}$	Propagation Delay to Output CLK to SOUT (Note 10) CLK to CL/4 CLK to CL/8 SYNC to CL/4, CL/8	1020 650 800 650	1200 850 1050 850	1480 1050 1300 1100	1020 650 800 650	1200 850 1050 850	1480 1050 1300 1100	1020 650 800 650	1200 850 1050 850	1480 1050 1300 1100	ps
$t_s$	Setup Time (Note 11) SIN, Dn	-200	-450		-200	-450		-200	-450		ps
$t_h$	Hold Time (Note 11) SIN, Dn	900	650		900	650		900	650		ps
$t_{RR}$	Reset Recovery Time SYNC	500	300		500	300		500	300		ps
$t_{PW}$	Min Pulse Width CLK, MR	300			300			300			ps
$t_{JITTER}$	Random Clock Jitter (RMS)		< 1			< 1			< 1		ps
$V_{PP}$	Input Voltage Swing (Differential Configuration)	150		1000	150		1000	150		1000	mV
$t_r$ $t_f$	Rise/Fall Times (20% - 80%) Other SOUT	100 200	225 425	350 650	100 200	225 425	350 650	100 200	225 425	350 650	ps

NOTE: Device will meet the specifications after thermal equilibrium has been established when mounted in a test socket or printed circuit board with maintained transverse airflow greater than 500 lfm. Electrical parameters are guaranteed only over the declared operating temperature range. Functional operation of the device exceeding these conditions is not implied. Device specification limit values are applied individually under normal operating conditions and not valid simultaneously.

- 9. 10 Series:  $V_{EE}$  can vary  $-0.46\text{ V} / +0.06\text{ V}$ .  
100 Series:  $V_{EE}$  can vary  $-0.46\text{ V} / +0.8\text{ V}$ .
- 10. Propagation delays measured from negative going clock edge.
- 11. Relative to negative clock edge.

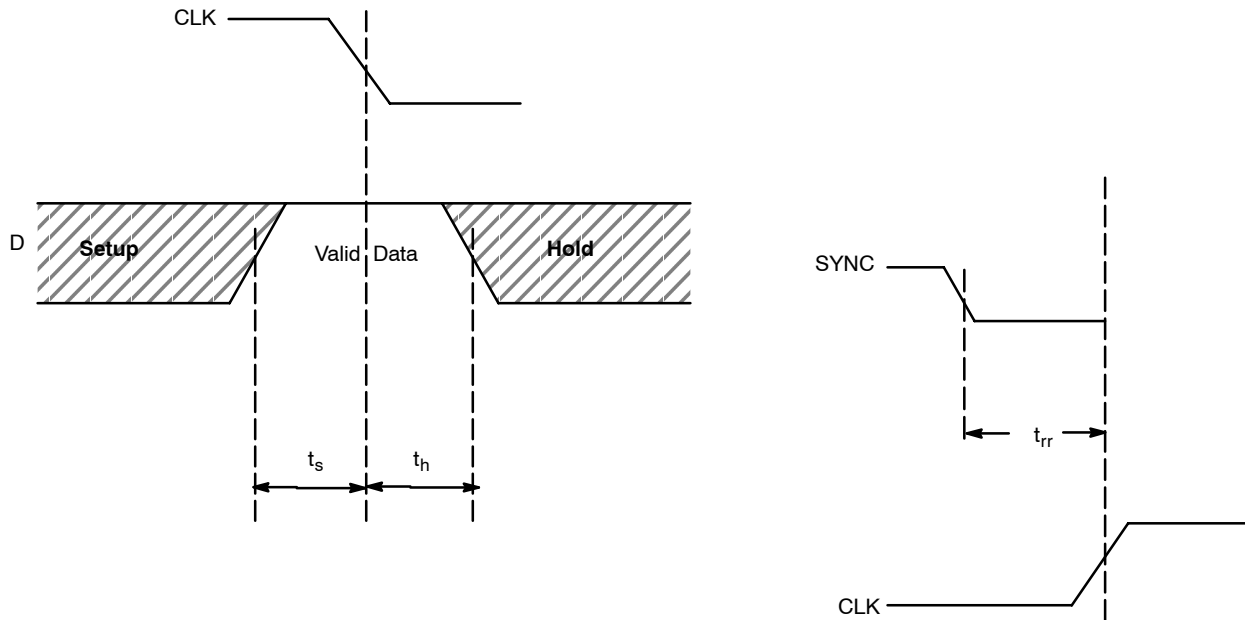
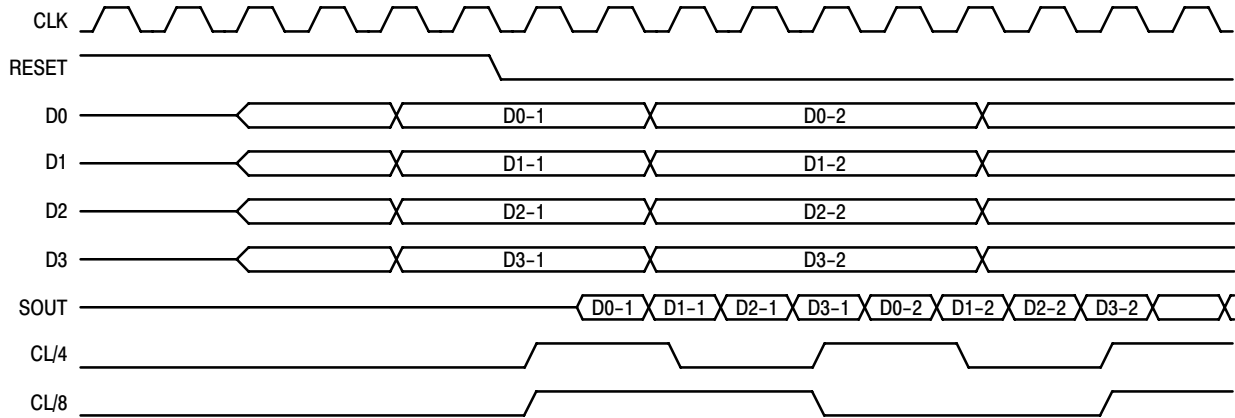
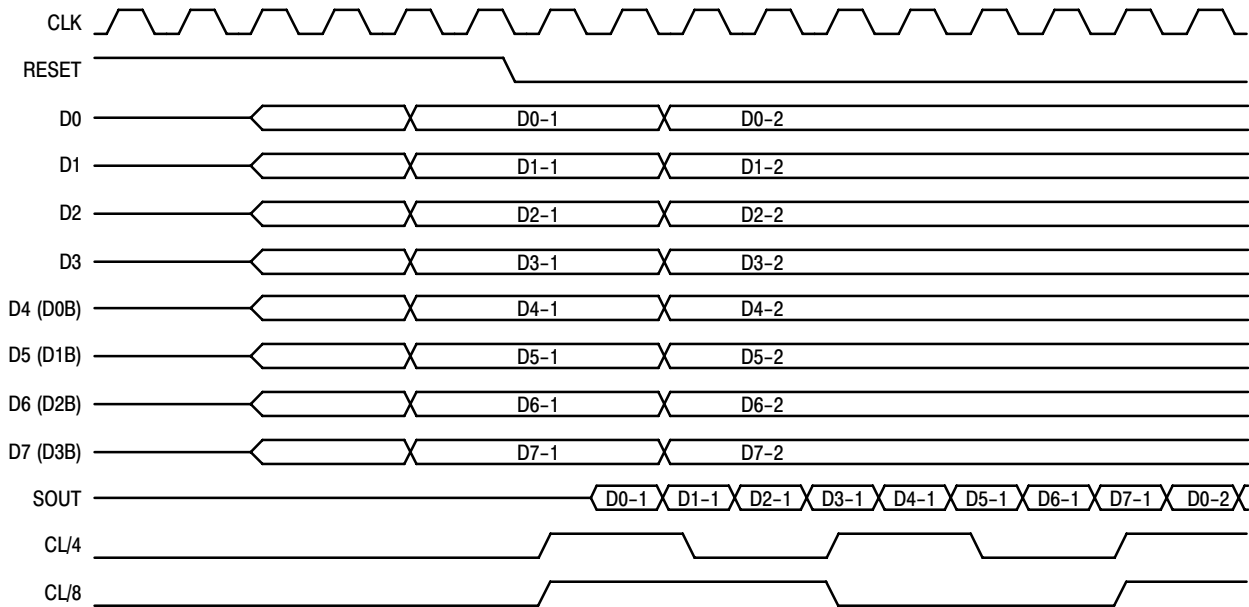

Figure 3.

# MC10E446, MC100E446



Timing Diagram A. 4:1 Parallel to Serial Conversion



Timing Diagram B. 8:1 Parallel to Serial Conversion

Figure 4. Timing Diagrams

# MC10E446, MC100E446

## Applications Information

The MC10E/100E446 is an integrated 4:1 parallel to serial converter. The chip is designed to work with the E445 device to provide both transmission and receiving of a high speed serial data path. The E446 can convert 4 bits of data into a 1.3 Gb/s NRZ data stream. The device features a SYNC input which allows the user to reset the internal clock circuitry and restart the conversion sequence (see timing diagram A).

The E446 features a differential serial input and internal divide by 8 circuitry to facilitate the cascading of two devices to build a 8:1 multiplexer. Figure 1 illustrates the architecture for a 8:1 multiplexer using two E446's; the timing diagram for this configuration can be found on the following page. Notice the serial outputs (SOUT) of the higher order converter feed the serial inputs of the lower order device. This feed through of the serial inputs bounds the upper end of the frequency of operation. The clock to serial output propagation delay plus the setup time of the serial input pins must fit into a single clock period for the cascade architecture to function properly. Using the worst case values for these two parameters from the data sheet,  $T_{pd} \text{ CLK to SOUT} = 1480 \text{ ps}$  and  $t_S \text{ for SIN} = -200 \text{ ps}$ , yields a minimum period of 1280 ps or a clock frequency of 780 MHz.

The clock frequency is somewhat lower than that of a single converter, to increase this frequency some games can be played with the clock input of the higher order E446. By

delaying the clock feeding E446A relative to the clock of E446B the frequency of operation can be increased.

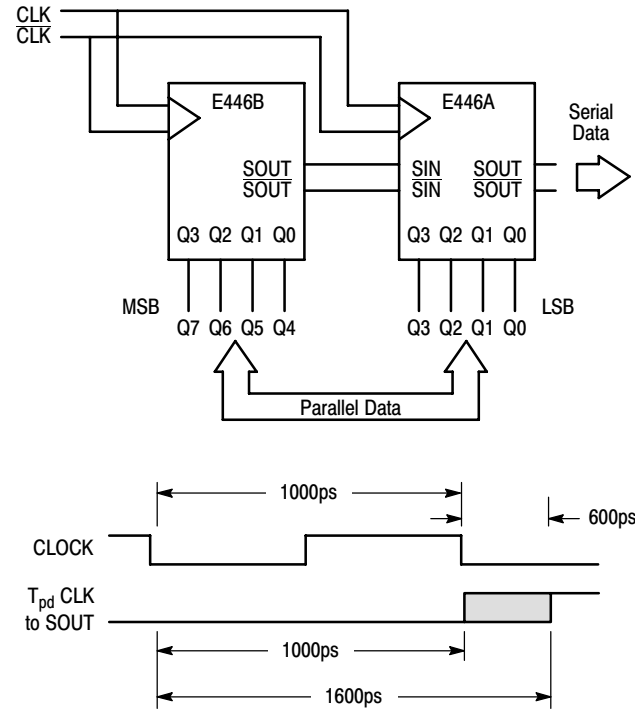
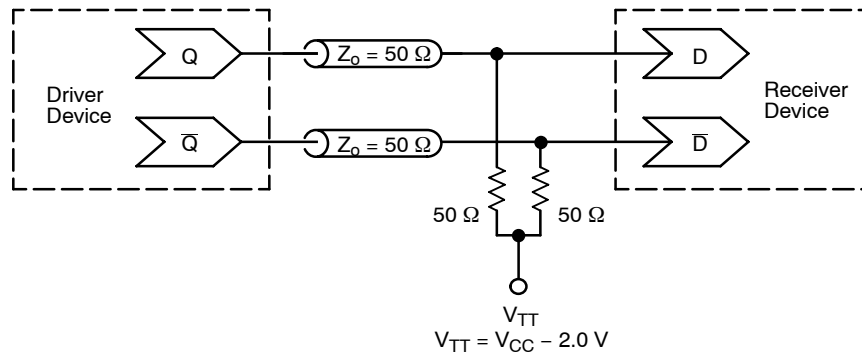

Figure 5. Cascaded 8:1 Converter Architecture

## MC10E446, MC100E446



**Figure 6. Typical Termination for Output Driver and Device Evaluation**  
(See Application Note AND8020/D – Termination of ECL Logic Devices.)

### ORDERING INFORMATION

Device	Package	Shipping <sup>†</sup>
MC10E446FN	PLCC-28	37 Units / Rail
MC10E446FNG	PLCC-28 (Pb-Free)	37 Units / Rail
MC10E446FNR2	PLCC-28	500 / Tape & Reel
MC10E446FNR2G	PLCC-28 (Pb-Free)	500 / Tape & Reel
MC100E446FN	PLCC-28	37 Units / Rail
MC100E446FNG	PLCC-28 (Pb-Free)	37 Units / Rail
MC100E446FNR2	PLCC-28	500 / Tape & Reel
MC100E446FNR2G	PLCC-28 (Pb-Free)	500 / Tape & Reel

<sup>†</sup>For information on tape and reel specifications, including part orientation and tape sizes, please refer to our Tape and Reel Packaging Specifications Brochure, BRD8011/D.

#### Resource Reference of Application Notes

- AN1405/D** – ECL Clock Distribution Techniques
- AN1406/D** – Designing with PECL (ECL at +5.0 V)
- AN1503/D** – ECLinPS™ I/O SPICE Modeling Kit
- AN1504/D** – Metastability and the ECLinPS Family
- AN1568/D** – Interfacing Between LVDS and ECL
- AN1672/D** – The ECL Translator Guide
- AND8001/D** – Odd Number Counters Design
- AND8002/D** – Marking and Date Codes
- AND8020/D** – Termination of ECL Logic Devices
- AND8066/D** – Interfacing with ECLinPS
- AND8090/D** – AC Characteristics of ECL Devices

# MC10E446, MC100E446

## PACKAGE DIMENSIONS

PLCC-28  
FN SUFFIX  
PLASTIC PLCC PACKAGE  
CASE 776-02  
ISSUE E

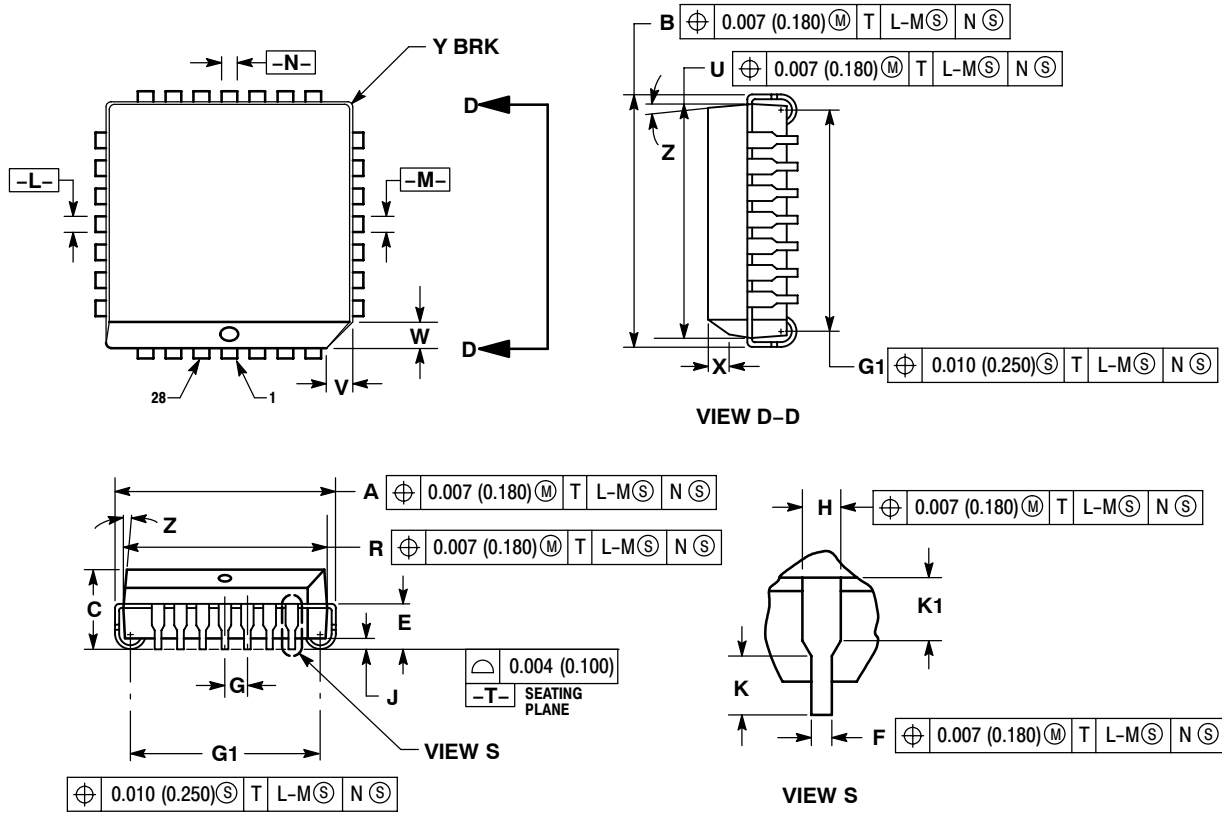

**NOTES:**

- DATUMS -L-, -M-, AND -N- DETERMINED WHERE TOP OF LEAD SHOULDER EXITS PLASTIC BODY AT MOLD PARTING LINE.
- DIMENSION G1, TRUE POSITION TO BE MEASURED AT DATUM -T-, SEATING PLANE.
- DIMENSIONS R AND U DO NOT INCLUDE MOLD FLASH. ALLOWABLE MOLD FLASH IS 0.010 (0.250) PER SIDE.
- DIMENSIONING AND TOLERANCING PER ANSI Y14.5M, 1982.
- CONTROLLING DIMENSION: INCH.
- THE PACKAGE BOTTOM MAY BE SMALLER THAN THE PACKAGE TOP BY UP TO 0.012 (0.300). DIMENSIONS R AND U ARE DETERMINED AT THE OUTERMOST EXTREMES OF THE PLASTIC BODY EXCLUSIVE OF MOLD FLASH, TIE BAR BURRS, GATE BURRS AND INTERLEAD FLASH, BUT INCLUDING ANY MISMATCH BETWEEN THE TOP AND BOTTOM OF THE PLASTIC BODY.
- DIMENSION H DOES NOT INCLUDE DAMBAR PROTRUSION OR INTRUSION. THE DAMBAR PROTRUSION(S) SHALL NOT CAUSE THE H DIMENSION TO BE GREATER THAN 0.037 (0.940). THE DAMBAR INTRUSION(S) SHALL NOT CAUSE THE H DIMENSION TO BE SMALLER THAN 0.025 (0.635).

DIM	INCHES		MILLIMETERS	
	MIN	MAX	MIN	MAX
A	0.485	0.495	12.32	12.57
B	0.485	0.495	12.32	12.57
C	0.165	0.180	4.20	4.57
E	0.090	0.110	2.29	2.79
F	0.013	0.019	0.33	0.48
G	0.050 BSC		1.27 BSC	
H	0.026	0.032	0.66	0.81
J	0.020	---	0.51	---
K	0.025	---	0.64	---
R	0.450	0.456	11.43	11.58
U	0.450	0.456	11.43	11.58
V	0.042	0.048	1.07	1.21
W	0.042	0.048	1.07	1.21
X	0.042	0.056	1.07	1.42
Y	---	0.020	---	0.50
Z	2° 10°		2° 10°	
G1	0.410	0.430	10.42	10.92
K1	0.040	---	1.02	---

# MC10E446, MC100E446

ECLinPS is a trademark of Semiconductor Components Industries, LLC (SCILLC).

**ON Semiconductor** and **ON** are registered trademarks of Semiconductor Components Industries, LLC (SCILLC). SCILLC reserves the right to make changes without further notice to any products herein. SCILLC makes no warranty, representation or guarantee regarding the suitability of its products for any particular purpose, nor does SCILLC assume any liability arising out of the application or use of any product or circuit, and specifically disclaims any and all liability, including without limitation special, consequential or incidental damages. "Typical" parameters which may be provided in SCILLC data sheets and/or specifications can and do vary in different applications and actual performance may vary over time. All operating parameters, including "Typicals" must be validated for each customer application by customer's technical experts. SCILLC does not convey any license under its patent rights nor the rights of others. SCILLC products are not designed, intended, or authorized for use as components in systems intended for surgical implant into the body, or other applications intended to support or sustain life, or for any other application in which the failure of the SCILLC product could create a situation where personal injury or death may occur. Should Buyer purchase or use SCILLC products for any such unintended or unauthorized application, Buyer shall indemnify and hold SCILLC and its officers, employees, subsidiaries, affiliates, and distributors harmless against all claims, costs, damages, and expenses, and reasonable attorney fees arising out of, directly or indirectly, any claim of personal injury or death associated with such unintended or unauthorized use, even if such claim alleges that SCILLC was negligent regarding the design or manufacture of the part. SCILLC is an Equal Opportunity/Affirmative Action Employer. This literature is subject to all applicable copyright laws and is not for resale in any manner.

## PUBLICATION ORDERING INFORMATION

### LITERATURE FULFILLMENT:

Literature Distribution Center for ON Semiconductor  
P.O. Box 5163, Denver, Colorado 80217 USA  
**Phone:** 303-675-2175 or 800-344-3860 Toll Free USA/Canada  
**Fax:** 303-675-2176 or 800-344-3867 Toll Free USA/Canada  
**Email:** [orderlit@onsemi.com](mailto:orderlit@onsemi.com)

**N. American Technical Support:** 800-282-9855 Toll Free  
USA/Canada  
**Europe, Middle East and Africa Technical Support:**  
Phone: 421 33 790 2910  
**Japan Customer Focus Center**  
Phone: 81-3-5773-3850

**ON Semiconductor Website:** [www.onsemi.com](http://www.onsemi.com)  
**Order Literature:** <http://www.onsemi.com/orderlit>

For additional information, please contact your local  
Sales Representative

## Looking for pricing, stock, or lifecycle information?

Click below to explore more details on WIN SOURCE:

 [View MC100E446FNG](#) on WIN SOURCE

 [ON Semiconductor](#) Information

## Optimize Your Supply Chain with WIN SOURCE Solutions

-  Global Sourcing Solution
-  Obsolete Management
-  Cost Control Management
-  Shortage Management
-  Alternative Solution
-  Excess Inventory Management