



**THE DATASHEET OF
INA126UA/2K5**



INAx126 MicroPower Instrumentation Amplifier Single and Dual Versions

1 Features

- Low Quiescent Current: 175 μ A/channel
- Wide Supply Range: ± 1.35 V to ± 18 V
- Low Offset Voltage: 250- μ V Maximum
- Low Offset Drift: 3- μ V/ $^{\circ}$ C Maximum
- Low Noise: 35 nV/ $\sqrt{\text{Hz}}$
- Low Input Bias Current: 25-nA Maximum
- 8-Pin PDIP, SOIC, VSSOP Surface-Mount Dual: 16-Pin PDIP, SOIC, SSOP

2 Applications

- Industrial Sensor Amplifiers: Bridges, RTDs, Thermocouples
- Physiological Amplifiers: ECGs, EEGs, EMGs
- Multi-Channel Data Acquisition
- Portable, Battery-Operated Systems

3 Description

The INA126 and INA2126 are precision instrumentation amplifiers for accurate, low noise differential-signal acquisition. Their two-op-amp design provides excellent performance with low quiescent current (175 μ A/channel). Combined with a wide operating voltage range of ± 1.35 V to ± 18 V, makes the INAx126 ideal for portable instrumentation and data acquisition systems.

Gain can be set from 5 V/V to 10000 V/V with a single external resistor. Laser-trimmed input circuitry provides low offset voltage (250- μ V maximum), low offset voltage drift (3- μ V/ $^{\circ}$ C maximum), and excellent common-mode rejection.

Single version package options include 8-pin plastic PDIP, SOIC-8, and fine-pitch VSSOP-8 surface-mount. Dual version is available in 16-pin plastic PDIP, SOIC-8, and the space-saving, fine-pitch SSOP-16 surface-mount. All are specified for the -40° C to $+85^{\circ}$ C industrial temperature range.

Device Information⁽¹⁾

PART NUMBER	PACKAGE	BODY SIZE (NOM)
INA126	PDIP (8)	6.35 mm x 9.81 mm
	SOIC (8)	3.91 mm x 4.90 mm
	VSSOP (8)	3.00 mm x 3.00 mm
INA2126	PDIP (16)	6.35 mm x 19.30 mm
	SOIC (16)	3.91 mm x 9.90 mm
	SSOP (16)	3.90 mm x 4.90 mm

(1) For all available packages, see the orderable addendum at the end of the data sheet.

Simplified Schematic: INA126

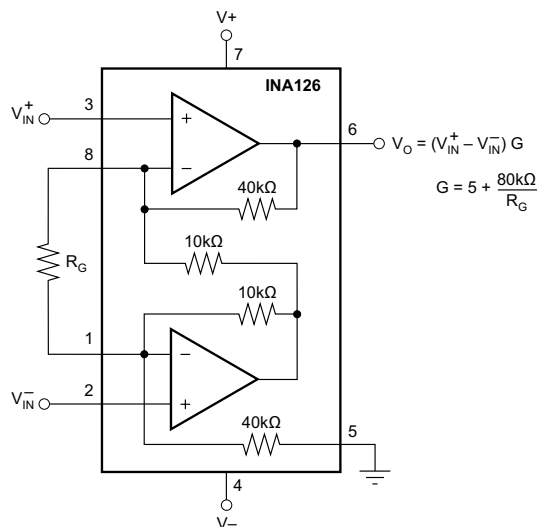

Simplified Schematic: INA2126

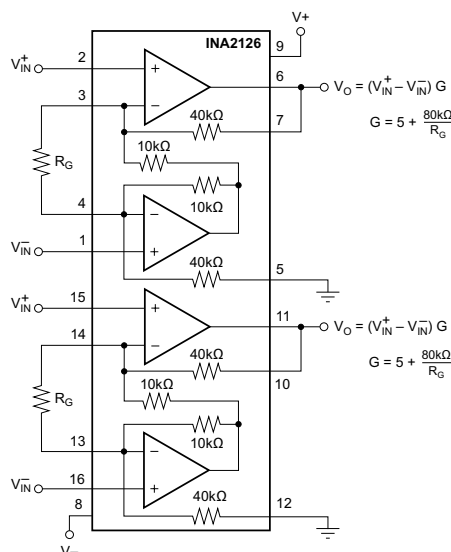

Table of Contents

1 Features	1	7.4 Device Functional Modes.....	11
2 Applications	1	8 Application and Implementation	12
3 Description	1	8.1 Application Information.....	12
4 Revision History	2	8.2 Typical Application	12
5 Pin Configuration and Functions	3	9 Power Supply Recommendations	16
6 Specifications	5	9.1 Low Voltage Operation	16
6.1 Absolute Maximum Ratings	5	10 Layout	17
6.2 ESD Ratings	5	10.1 Layout Guidelines	17
6.3 Recommended Operating Conditions.....	5	10.2 Layout Example	18
6.4 Thermal Information: INA126.....	5	11 Device and Documentation Support	19
6.5 Thermal Information: INA2126.....	6	11.1 Related Links	19
6.6 Electrical Characteristics.....	6	11.2 Community Resources.....	19
6.7 Typical Characteristics.....	8	11.3 Trademarks	19
7 Detailed Description	11	11.4 Electrostatic Discharge Caution.....	19
7.1 Overview	11	11.5 Glossary	19
7.2 Functional Block Diagram	11	12 Mechanical, Packaging, and Orderable	19
7.3 Feature Description.....	11	Information	19

4 Revision History

NOTE: Page numbers for previous revisions may differ from page numbers in the current version.

Changes from Revision A (August 2005) to Revision B	Page
<ul style="list-style-type: none"> Added <i>ESD Ratings</i> table, <i>Feature Description</i> section, <i>Device Functional Modes</i>, <i>Application and Implementation</i> section, <i>Power Supply Recommendations</i> section, <i>Layout</i> section, <i>Device and Documentation Support</i> section, and <i>Mechanical, Packaging, and Orderable Information</i> section 	1

5 Pin Configuration and Functions

**P, D, and DGK Packages
8-Pin PDIP, SOIC, VSSOP
Top View**

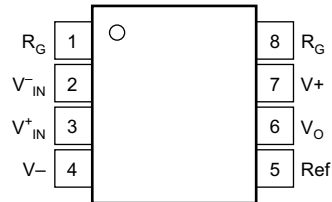

Pin Functions: 8-Pin

PIN		I/O	DESCRIPTION
NO.	NAME		
1, 8	R_G	—	Gain setting pin. For gains greater than 5 place a gain resistor between pin 1 and pin 8.
2	V_{-IN}	I	Negative input
3	V_{+IN}	I	Positive input
4	V_-	—	Negative supply
5	Ref	I	Reference input. This pin must be driven by a low impedance or connected to ground.
6	V_O	O	Output
7	V_+	—	Positive supply

**N, D, and DBQ Packages
16-Pin PDIP, SOIC, SSOP
Top View**

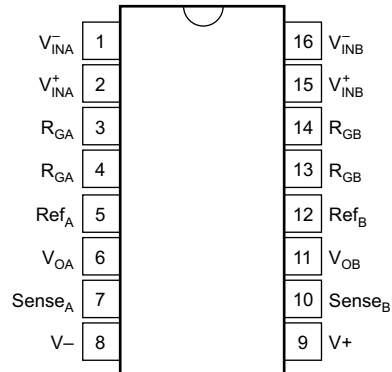

Pin Functions: 16-Pin

PIN		I/O	DESCRIPTION
NO.	NAME		
1	V_{-INA}	I	Negative input for amplifier A
2	V_{+INA}	I	Positive input for amplifier A
3, 4	R_{GA}	—	Gain setting pin for amplifier A. For gains greater than 5 place a gain resistor between pin 3 and pin 4.
5	Ref_A	I	Reference input for amplifier A. This pin must be driven by a low impedance or connected to ground.
6	V_{OA}	O	Output of amplifier A
7	$Sense_A$	I	Feedback for amplifier A. Connect to V_{OA} , amplifier A output.
8	V_-	—	Negative supply
9	V_+	—	Positive supply
10	$Sense_B$	I	Feedback for amplifier B. Connect to V_{OB} , amplifier B output.
11	V_{OB}	O	Output of amplifier B
12	Ref_B	I	Reference input for amplifier B. This pin must be driven by a low impedance or connected to ground.
13, 14	R_{GB}	—	Gain setting pin for amplifier B. For gains greater than 5 place a gain resistor between pin 13 and pin 14.
15	V_{+INB}	I	Positive input for amplifier B
16	V_{-INB}	I	Negative input for amplifier B

6 Specifications

6.1 Absolute Maximum Ratings

over operating free-air temperature range (unless otherwise noted) ⁽¹⁾

	MIN	MAX	UNIT
Power supply voltage, V+ to V–		36	V
Input signal voltage ⁽²⁾	(V–) – 0.7	(V+) + 0.7	
Input signal current ⁽²⁾		10	mA
Output short circuit		Continuous	
Operating temperature	–55	125	°C
Lead temperature (soldering, 10 s)		300	°C
Storage temperature, T _{stg}	–55	125	°C

- (1) Stresses beyond those listed under *Absolute Maximum Ratings* may cause permanent damage to the device. These are stress ratings only, which do not imply functional operation of the device at these or any other conditions beyond those indicated under *Recommended Operating Conditions*. Exposure to absolute-maximum-rated conditions for extended periods may affect device reliability.
- (2) Input signal voltage is limited by internal diodes connected to power supplies. See text.

6.2 ESD Ratings

	VALUE	UNIT	
V _(ESD) Electrostatic discharge	Human-body model (HBM), per ANSI/ESDA/JEDEC JS-001 ⁽¹⁾	±500	V

- (1) JEDEC document JEP155 states that 500-V HBM allows safe manufacturing with a standard ESD control process.

6.3 Recommended Operating Conditions

over operating free-air temperature range (unless otherwise noted)

	MIN	NOM	MAX	UNIT
V+ V power supply	±135	±15	±18	V
V _O Input common mode voltage for V _O = 0		±11.25		V
T _A Operating temperature	–55		125	°C

6.4 Thermal Information: INA126

THERMAL METRIC ⁽¹⁾	INA126			UNIT
	PDIP	SOIC	MSOP	
	8 PINS	8 PINS	8 PINS	
R _{θJA} Junction-to-ambient thermal resistance	52.2	116.4	167.8	°C/W
R _{θJC(top)} Junction-to-case (top) thermal resistance	41.6	62.4	60.9	°C/W
R _{θJB} Junction-to-board thermal resistance	29.4	57.7	88.9	°C/W
ψ _{JT} Junction-to-top characterization parameter	18.9	10	7.3	°C/W
ψ _{JB} Junction-to-board characterization parameter	29.2	57.1	87.3	°C/W
R _{θJC(bot)} Junction-to-case (bottom) thermal resistance	–	–	–	°C/W

- (1) For more information about traditional and new thermal metrics, see the *Semiconductor and IC Package Thermal Metrics* application report, [SPRA953](#).

6.5 Thermal Information: INA2126

THERMAL METRIC ⁽¹⁾		INA2126			UNIT
		PDIP	SOIC	MSOP	
		16 PINS	16 PINS	16 PINS	
R _{θJA}	Junction-to-ambient thermal resistance	39.3	76.2	115.8	°C/W
R _{θJC(top)}	Junction-to-case (top) thermal resistance	26.2	37.8	67	°C/W
R _{θJB}	Junction-to-board thermal resistance	20.1	33.5	58.3	°C/W
ψ _{JT}	Junction-to-top characterization parameter	10.7	7.5	19.9	°C/W
ψ _{JB}	Junction-to-board characterization parameter	19.9	33.3	57.9	°C/W
R _{θJC(bot)}	Junction-to-case (bottom) thermal resistance	–	–	–	°C/W

(1) For more information about traditional and new thermal metrics, see the *Semiconductor and IC Package Thermal Metrics* application report, [SPRA953](#).

6.6 Electrical Characteristics

at T_A = 25°C, V_S = ±15 V, R_L = 25 kΩ (unless otherwise noted)

PARAMETER		TEST CONDITIONS		MIN	TYP	MAX	UNIT
INPUT							
RTI	Offset voltage	NA126P, U, E; INA2126P, U, E			±100	±250	μV
		INA126PA, UA, EA; INA2126PA, UA, EA			±150	±500	
	Offset voltage versus temperature	NA126P, U, E; INA2126P, U, E			±0.5	±3	μV/°C
		INA126PA, UA, EA; INA2126PA, UA, EA			±0.5	±5	
Offset voltage versus power supply (PSRR)	V _S = ±1.35 V to ±18	VNA126P, U, E INA2126P, U, E			5	15	μV/V
		VINA126PA, UA, EA INA2126PA, UA, EA			5	50	
Input impedance	INA126P, U, E; INA2126P, U, E			10 ⁹ 4			Ω pF
Safe input voltage	R _S = 0		(V–) – 0.5			(V+) + 0.5	V
	R _S = 1 kΩ		(V–) – 10			(V+) + 10	
Common-mode voltage range	V _O = 0 V		±11.25		±11.5		V
Channel separation (dual)	G = 5, dc				130		dB
Common-mode rejection	R _S = 0, V _{CM} = ±11.25 V	INA126P, U, E INA2126P, U, E	83		94		dB
		INA126PA, UA, EA INA2126PA, UA, EA	74		90		
	NA2126U (dual SO-16)		80		94		
INPUT BIAS CURRENT							
Input bias current	INA126P, U, E; INA2126P, U, E				–10	–25	nA
	INA126PA, UA, EA; INA2126PA, UA, EA					–50	
Input bias current vs temperature					±30		pA/°C
Offset current	INA126P, U, E; INA2126P, U, E				±0.5	±2	nA
	INA126PA, UA, EA; INA2126PA, UA, EA				±0.5	±5	
Offset current vs temperature					±10		pA/°C
GAIN							
Gain					G = 5 to 10k		V/V
Gain equation					G = 5 + 80 kΩ/R _G		V/V
Gain error	V _O = ±14 V, G = 5	INA126P, U, E INA2126P, U, E			±0.02%	±0.1%	
		INA126PA, UA, EA INA2126PA, UA, EA			±0.02%	±0.18%	
Gain error vs temperature	G = 5				±2	±10	ppm/°C
Gain error	V _O = ±12 V, G = 100	INA126P, U, E INA2126P, U, E			±0.2%	±0.5%	
		INA126PA, UA, EA INA2126PA, UA, EA			±0.2%	±1%	
Gain error vs temperature	G = 100				±25	±100	ppm/°C

Electrical Characteristics (continued)

 at $T_A = 25^\circ\text{C}$, $V_S = \pm 15\text{ V}$, $R_L = 25\text{ k}\Omega$ (unless otherwise noted)

PARAMETER	TEST CONDITIONS	MIN	TYP	MAX	UNIT
Nonlinearity	$G = 100$, $V_O = \pm 14\text{ V}$		$\pm 0.002\%$	$\pm 0.012\%$	
NOISE					
Voltage noise	$f = 1\text{ kHz}$		35		nV/ $\sqrt{\text{Hz}}$
	$f = 100\text{ Hz}$		35		
	$f = 10\text{ Hz}$		45		
	$f_B = 0.1\text{ Hz to }10\text{ Hz}$		0.7		μV_{PP}
Current noise	$f = 1\text{ kHz}$		60		fA/ $\sqrt{\text{Hz}}$
	$f_B = 0.1\text{ Hz to }10\text{ Hz}$		2		pA_{PP}
OUTPUT					
Positive voltage	$R_L = 25\text{ k}\Omega$	$(V+) - 0.9$	$(V+) - 0.75$		V
Negative voltage	$R_L = 25\text{ k}\Omega$	$(V-) + 0.95$	$(V-) + 0.8$		
Short-circuit current	Short circuit to ground		+10 / -5		mA
Capacitive load drive			1000		pF
FREQUENCY RESPONSE					
Bandwidth, -3dB	$G = 5$		200		kHz
	$G = 100$		9		
	$G = 500$		1.8		
Slew rate	$V_O = \pm 10\text{ V}$, $G = 5$		0.4		V/ μs
Settling time, 0.01%	10-V step, $G = 5$		30		μs
	10-V step, $G = 100$		160		
	10-V step, $G = 500$		1500		
Overload recovery	50% input overload		4		μs
POWER SUPPLY					
Voltage range		± 1.35	± 15	± 18	V
Current (per channel)	$I_O = 0$		± 175	± 200	μA
Specification temperature range		-40		85	$^\circ\text{C}$
Operation temperature range		-55		125	$^\circ\text{C}$

6.7 Typical Characteristics

at $T_A = 25^\circ\text{C}$, $V_S = \pm 15\text{ V}$ (unless otherwise noted)

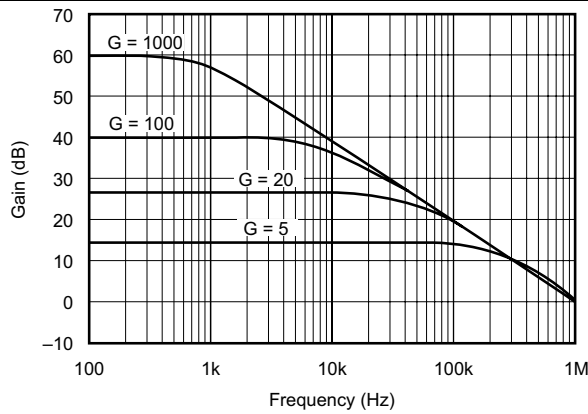

Figure 1. Gain vs Frequency

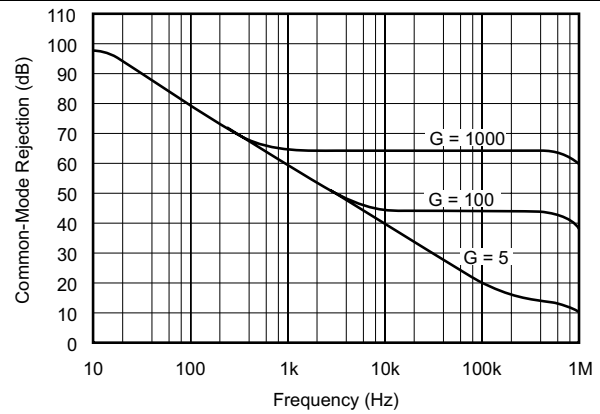

Figure 2. Common-Mode Rejection vs Frequency

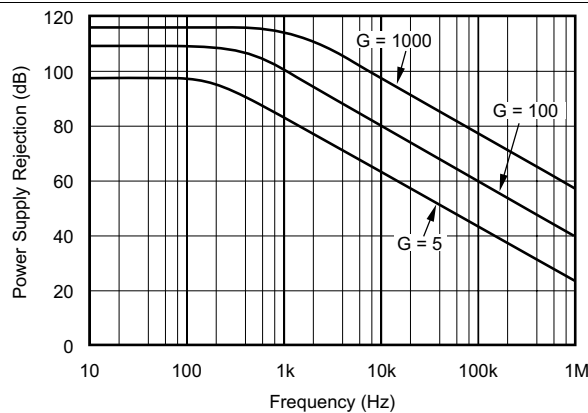

Figure 3. Positive Power Supply Rejection vs Frequency

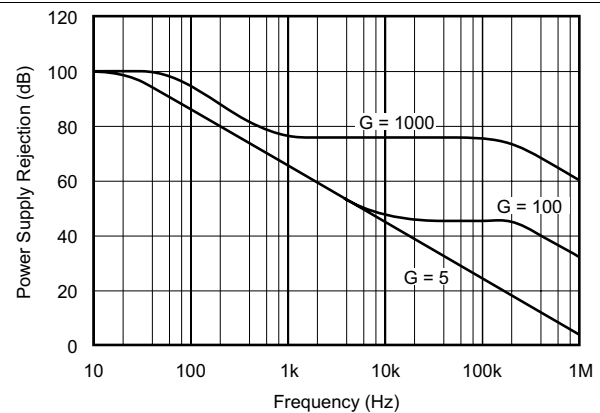

Figure 4. Negative Power Supply Rejection vs Frequency

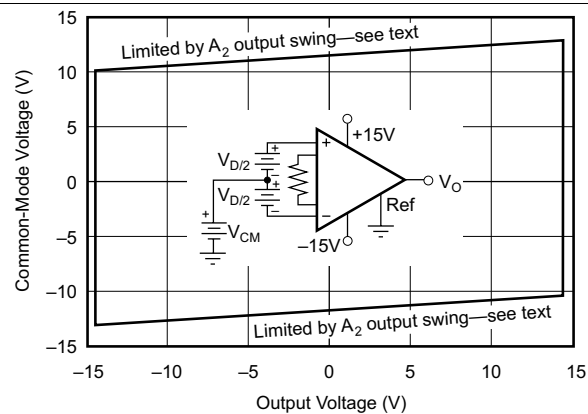

Figure 5. Input Common-Mode Range vs Output Voltage, $V_S = \pm 15\text{ V}$

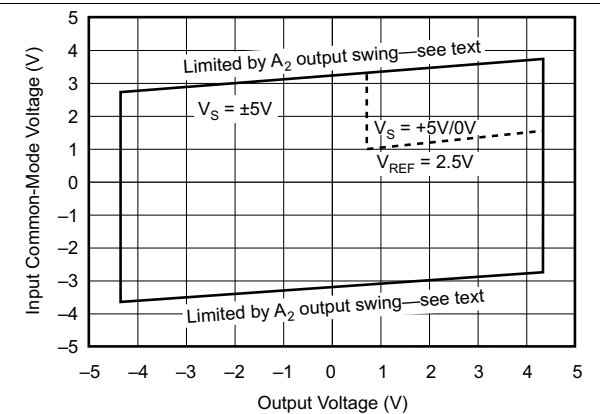
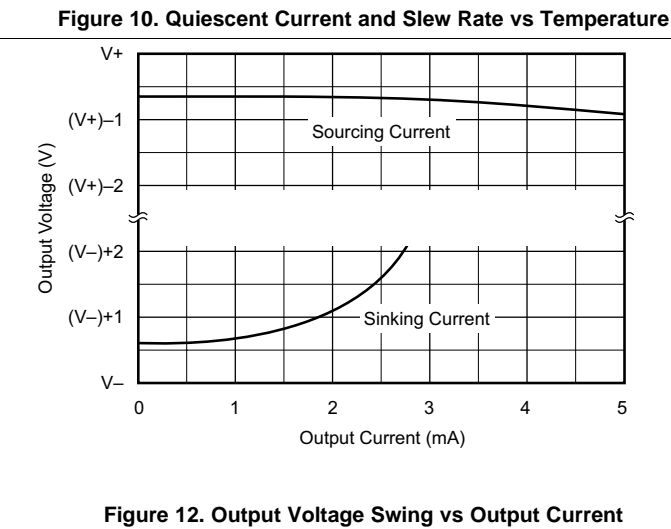
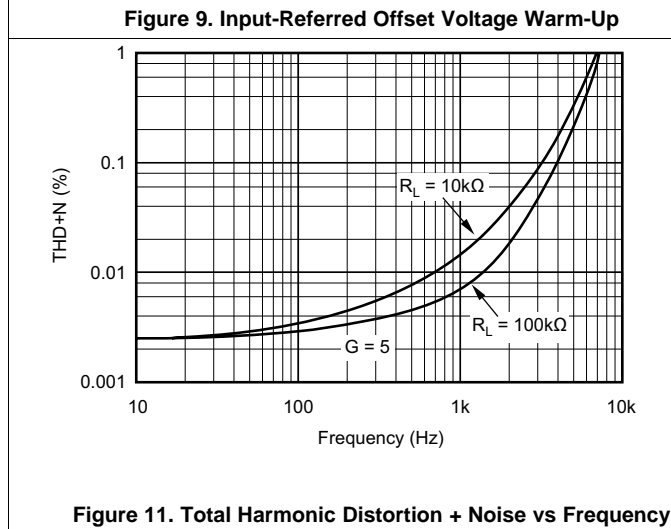
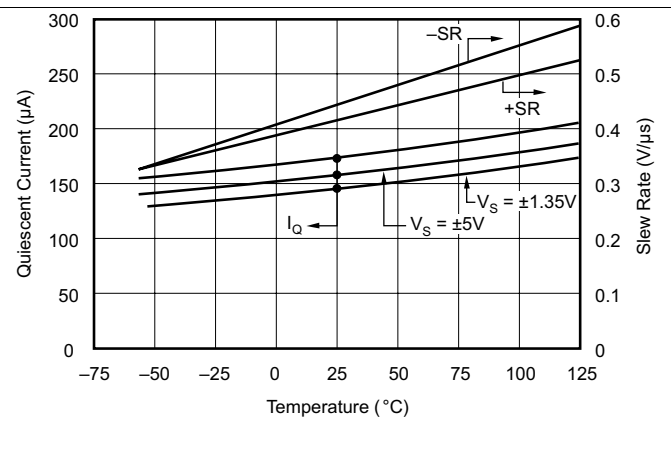
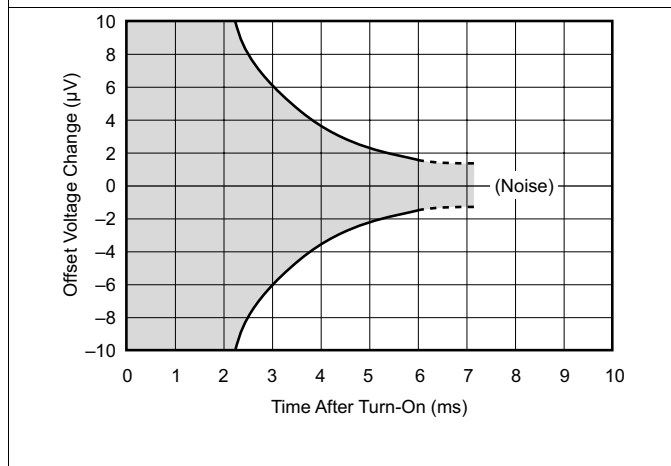
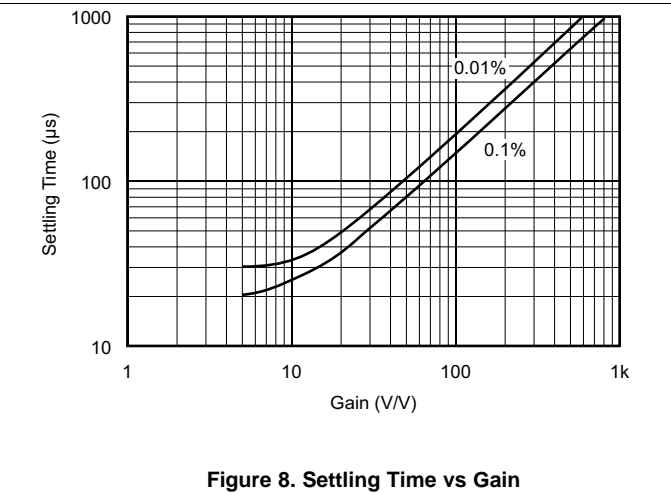
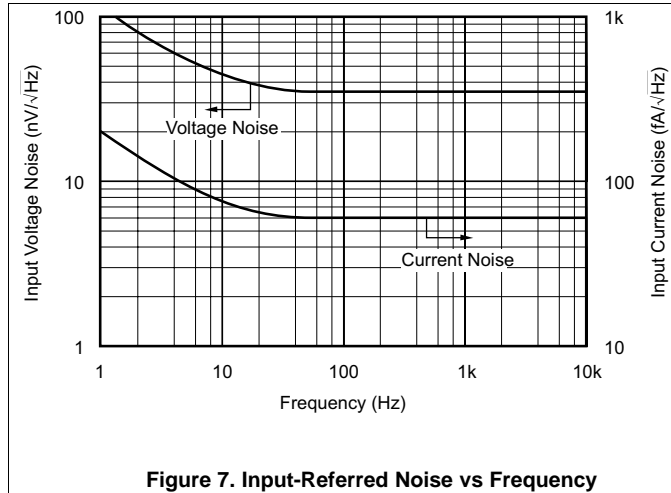

Figure 6. Input Common-Mode Voltage Range vs Output Voltage, $V_S = \pm 5\text{ V}$

Typical Characteristics (continued)

at $T_A = 25^\circ\text{C}$, $V_S = \pm 15\text{ V}$ (unless otherwise noted)



Typical Characteristics (continued)

at $T_A = 25^\circ\text{C}$, $V_S = \pm 15\text{ V}$ (unless otherwise noted)

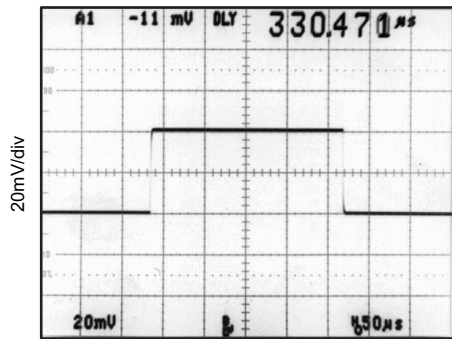

Figure 13. Small-Signal Response, $G = 5$

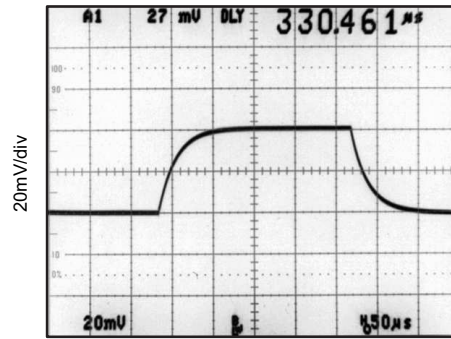

Figure 14. Small-Signal Response, $G = 100$

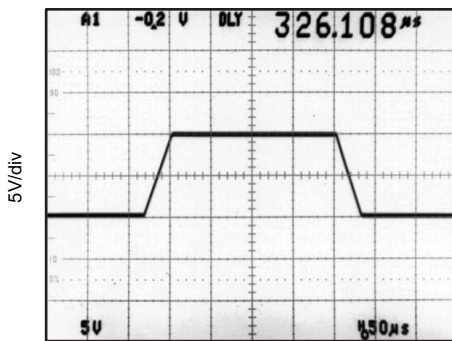

Figure 15. Large-Signal Response, $G = 5$

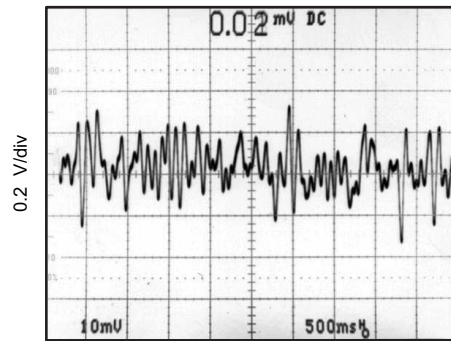

Figure 16. Voltage Noise, 0.1 Hz to 10 Hz

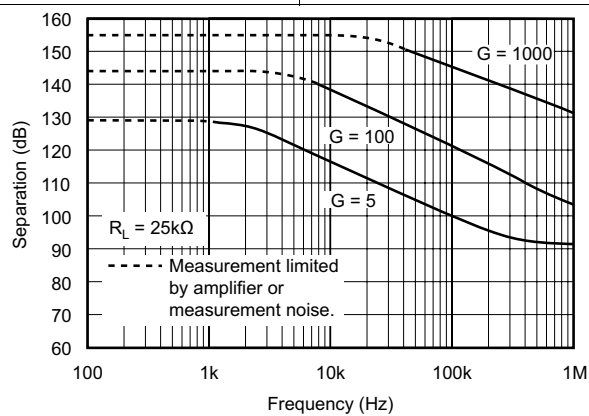

Figure 17. Channel Separation vs Frequency, RTI (Dual Version)

7 Detailed Description

7.1 Overview

The INAx126 use only two, rather than three, operational amplifiers providing savings in power consumption. In addition the input resistance is high and balanced, thus permitting the signal source to have an unbalanced output impedance.

A minimum circuit gain of 5 permits an adequate DC common mode input range, as well as sufficient bandwidth for most applications.

7.2 Functional Block Diagram

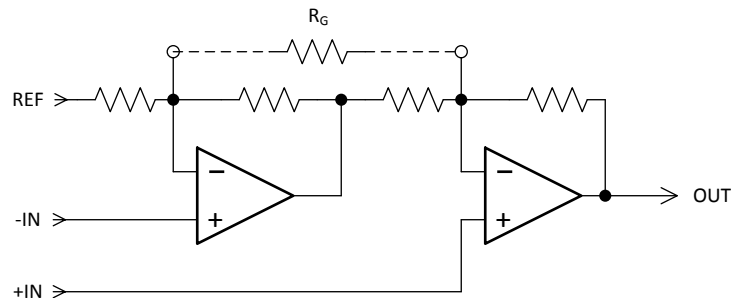

7.3 Feature Description

The INAx126 are low power, general-purpose instrumentation amplifiers offering excellent accuracy. The versatile two-operational-amplifier design and small size make the amplifiers ideal for a wide range of applications. The two op amp topology reduces power consumption. A single external resistor sets any gain from 5 to 10,000. These devices operate with power supplies as low as ± 1.35 V, and quiescent current of 200 μ A maximum.

7.4 Device Functional Modes

7.4.1 Single-Supply Operation

The INAx126 can be used on single power supplies of 2.7 V to 36 V. Use the output REF pin to level shift the internal output voltage into a linear operating condition. Ideally, connecting the REF pin to a potential that is midsupply avoids saturating the output of the amplifiers. See [Application Information](#) for information on how to adequately drive the reference pin.

8 Application and Implementation

NOTE

Information in the following applications sections is not part of the TI component specification, and TI does not warrant its accuracy or completeness. TI's customers are responsible for determining suitability of components for their purposes. Customers should validate and test their design implementation to confirm system functionality.

8.1 Application Information

The INAx126 measures small differential voltage with high common-mode voltage developed between the noninverting and inverting input. The high input impedance make the INAx126 suitable for a wide range of applications. The INAx126 can adjust the functionality of the output signals by setting the reference pin, giving additional flexibility that is practical for multiple configurations.

8.2 Typical Application

Figure 18 shows the basic connections required for operation of the INA126. Applications with noisy or high impedance power supplies may require decoupling capacitors close to the device pins as shown.

The output is referred to the output reference (Ref) terminal, which is normally grounded. This connection must be low-impedance to ensure good common-mode rejection. A resistance of 8 Ω in series with the Ref pin causes a typical device to degrade to approximately 80-dB CMR.

Figure 18 depicts a desired differential signal from a sensor at 1kHz and 5mV p-p superimposed on top of a 1-V p-p 60-Hz common mode signal (the 1-kHz signal can not be resolved in this scope trace). The FFT trace in Figure 22 shows the two signals. Figure 23 shows the clearly recovered differential signal at the output of the INA126 operating at a gain of 250. The FFT of figure 4 shows the 60-Hz common-mode is no longer visible.

The dual version (INA2126) has feedback-sense connections, Sense_A and Sense_B. These must be connected to their respective output terminals for proper operation. The sense connection can sense the output voltage directly at the load for best accuracy.

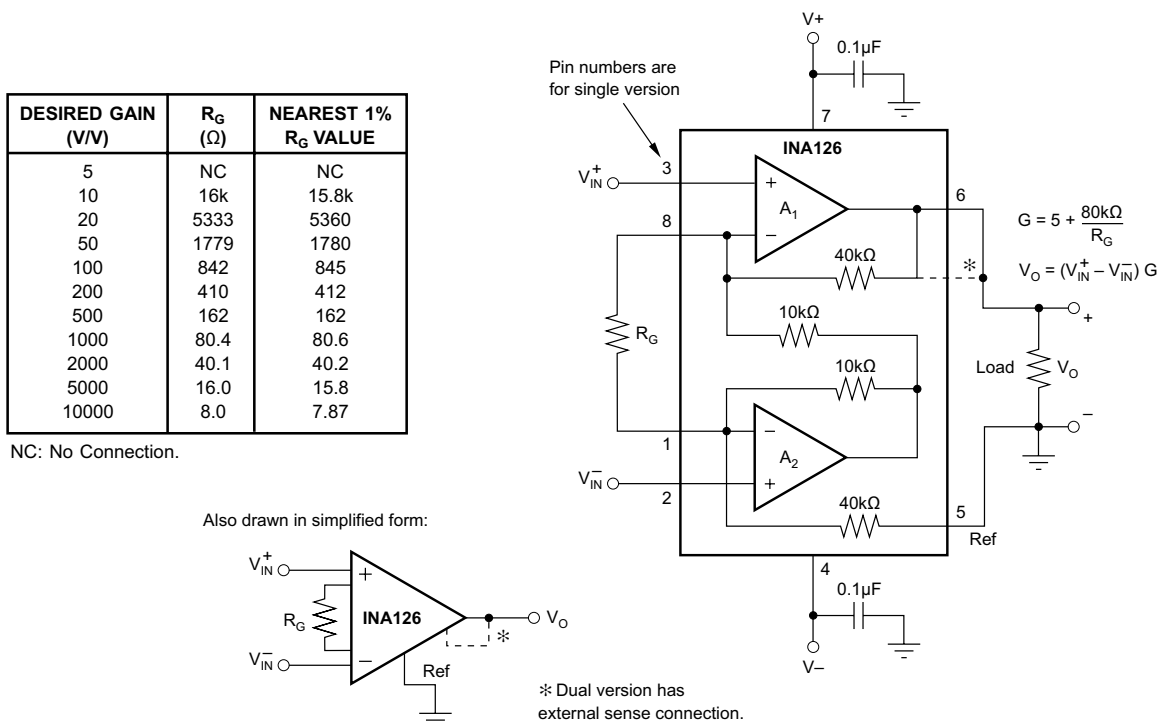

Figure 18. Basic Connections

Typical Application (continued)

8.2.1 Design Requirements

For the traces shown in [Figure 19](#) and [Figure 20](#):

- Common-mode rejection of at least 80dB
- Gain of 250

8.2.2 Detailed Design Procedure

8.2.2.1 Setting the Gain

Gain is set by connecting an external resistor, R_G :

$$g = 5 + 80 \text{ k}\Omega/R_G \quad (1)$$

Commonly used gains and R_G resistor values are shown in [Figure 18](#).

The 80-k Ω term in [Equation 1](#) comes from the internal metal film resistors, which are laser-trimmed to accurate absolute values. The accuracy and temperature coefficient of these resistors are included in the gain accuracy and drift specifications.

The stability and temperature drift of the external gain setting resistor, R_G , also affects gain. The R_G contribution to gain accuracy and drift can be directly inferred from [Equation 1](#). Low resistor values required for high gain can make wiring resistance important. Sockets add to the wiring resistance, which contributes additional gain error in gains of approximately 100 or greater.

8.2.2.2 Offset Trimming

The INAx126 are laser-trimmed for low offset voltage and offset voltage drift. Most applications require no external offset adjustment. [Figure 19](#) shows an optional circuit for trimming the output offset voltage. The voltage applied to the Ref terminal is added to the output signal. An operational amplifier buffer provides low impedance at the Ref terminal to preserve good common-mode rejection.

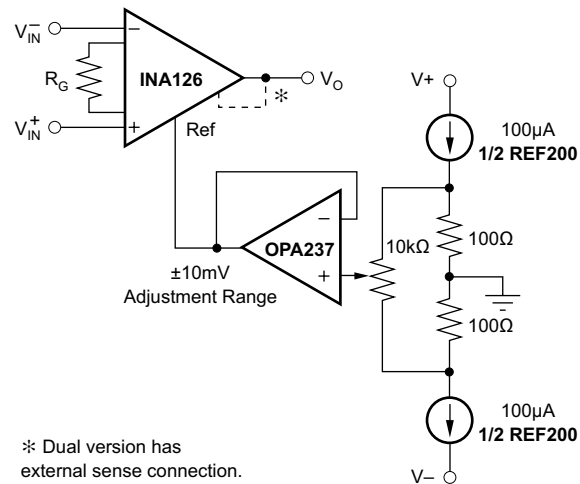

Figure 19. Optional Trimming of Output Offset Voltage

Typical Application (continued)

8.2.2.3 Input Bias Current Return

The input impedance of the INAx126 is extremely high, approximately 109 Ω. However, a path must be provided for the input bias current of both inputs. This input bias current is typically –10 nA (current flows out of the input terminals). High input impedance means that this input bias current changes very little with varying input voltage.

Input circuitry must provide a path for this input bias current for proper operation. [Figure 20](#) shows various provisions for an input bias current path. Without a bias current path, the inputs will float to a potential which exceeds the common-mode range, and the input amplifiers will saturate.

If the differential source resistance is low, the bias current return path can be connected to one input (see the thermocouple example in [Figure 20](#)). With higher source impedance, using two equal resistors provides a balanced input with the advantages of lower input offset voltage due to bias current and better high-frequency common-mode rejection.

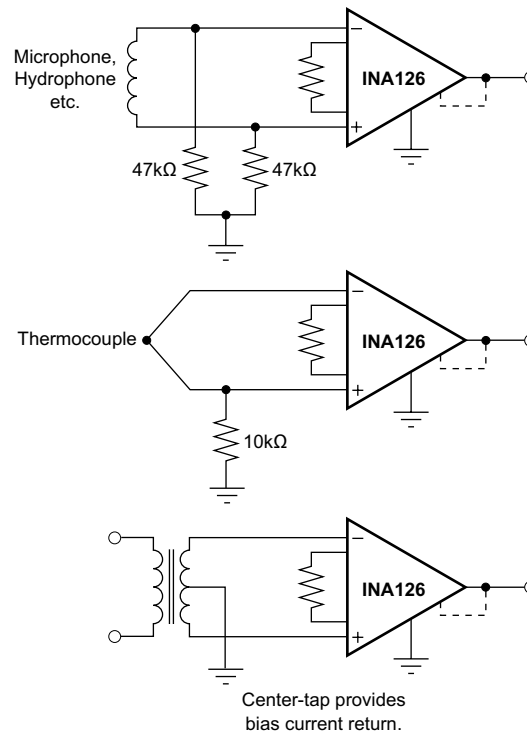

Figure 20. Providing an Input Common-Mode Current Path

8.2.2.4 Input Common-Mode Range

The input common-mode range of the INAx126 is shown in [Typical Characteristics](#). The common-mode range is limited on the negative side by the output voltage swing of A_2 , an internal circuit node that cannot be measured on an external pin. The output voltage of A_2 can be expressed as shown in [Equation 2](#):

$$V_{O2} = 1.25 V_{IN}^- - (V_{IN}^+ - V_{IN}^-) (10 \text{ k}\Omega / R_G)$$

where

- Voltages referred to Ref terminal, pin 5 (2)

The internal op amp A_2 is identical to A_1 , and its output swing is limited to typically 0.7 V from the supply rails. When the input common-mode range is exceeded (A_2 output is saturated), A_1 can still be in linear operation and respond to changes in the non-inverting input voltage. The output voltage, however, will be invalid.

Typical Application (continued)

8.2.2.5 Input Protection

The inputs are protected with internal diodes connected to the power supply rails. These diodes clamp the applied signal to prevent it from exceeding the power supplies by more than approximately 0.7 V. If the signal-source voltage can exceed the power supplies, the source current should be limited to less than 10 mA. This can generally be done with a series resistor. Some signal sources are inherently current-limited, and do not require limiting resistors.

8.2.2.6 Channel Crosstalk—Dual Version

The two channels of the INA2126 are completely independent, including all bias circuitry. At DC and low frequency, there is virtually no signal coupling between channels. Crosstalk increases with frequency and is dependent on circuit gain, source impedance, and signal characteristics.

As source impedance increases, careful circuit layout can help achieve lowest channel crosstalk. Most crosstalk is produced by capacitive coupling of signals from one channel to the input section of the other channel. To minimize coupling, separate the input traces as far as practical from any signals associated with the opposite channel. A grounded guard trace surrounding the inputs helps reduce stray coupling between channels. Carefully balance the stray capacitance of each input to ground, and run the differential inputs of each channel parallel to each other, or directly adjacent on top and bottom side of a circuit board. Stray coupling then tends to produce a common-mode signal that is rejected by the IA input.

8.2.3 Application Curves

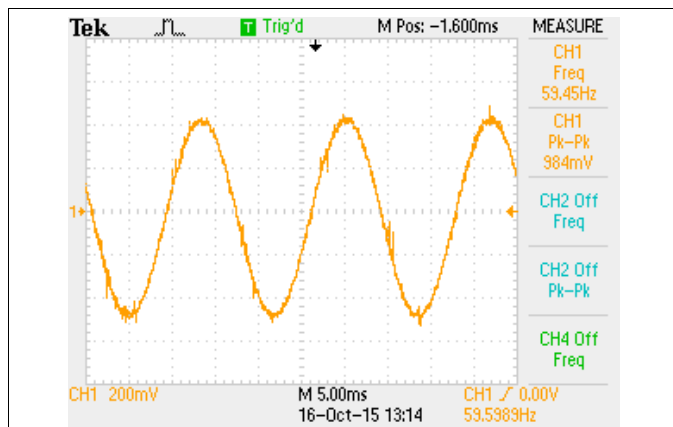

Differential signal is too small to be seen
Figure 21. Common-mode Signal at INA126 Input

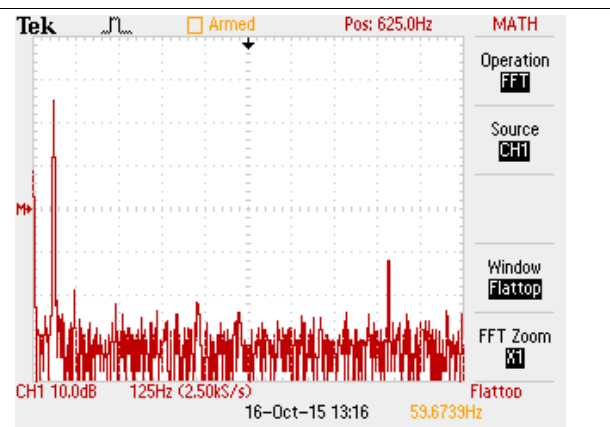

Figure 22. FFT of Signal in Figure 21 Shows Both the 60-Hz Common-mode Along With 5-kHz Differential Signal

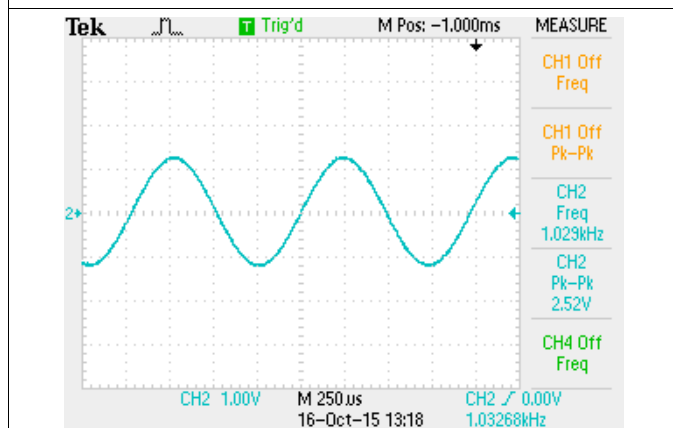

Figure 23. Recovered Differential Signal at the Output of the INA126 With a Gain of 250

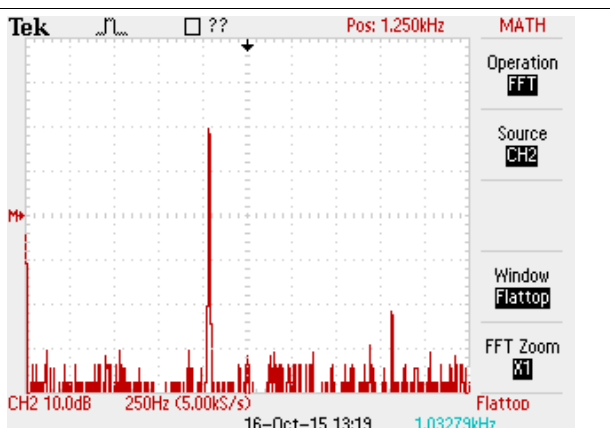

Figure 24. FFT of the INA126 Output Shows that the 60-Hz Common-mode Signal is Rejected

10 Layout

10.1 Layout Guidelines

Attention to good layout practices is always recommended. For best operational performance of the device, use good printed circuit board (PCB) layout practices, including:

- Take care to ensure that both input paths are well-matched for source impedance and capacitance to avoid converting common-mode signals into differential signals. In addition, parasitic capacitance at the gain-setting pins can also affect CMRR over frequency. For example, in applications that implement gain switching using switches or PhotoMOS® relays to change the value of RG, select the component so that the switch capacitance is as small as possible.
 - Connect low-ESR, 0.1- μ F ceramic bypass capacitors between each supply pin and ground, placed as close to the device as possible. A single bypass capacitor from V+ to ground is applicable for single-supply applications.
- Separate grounding for analog and digital portions of the circuitry is one of the simplest and most effective methods of noise suppression. One or more layers of multilayer PCBs are usually devoted to ground planes. A ground plane helps distribute heat and reduces EMI noise pickup. Make sure to physically separate digital and analog grounds, paying attention to the flow of the ground current. For more detailed information, see SLOA089, Circuit Board Layout Techniques.
- In order to reduce parasitic coupling, run the input traces as far away from the supply or output traces as possible. If these traces cannot be kept separate, crossing the sensitive trace perpendicular is much better than in parallel with the noisy trace.
- Place the external components as close to the device as possible. As illustrated in [Figure 26](#), keeping RG close to the pins minimizes parasitic capacitance.
- Keep the traces as short as possible

10.2 Layout Example

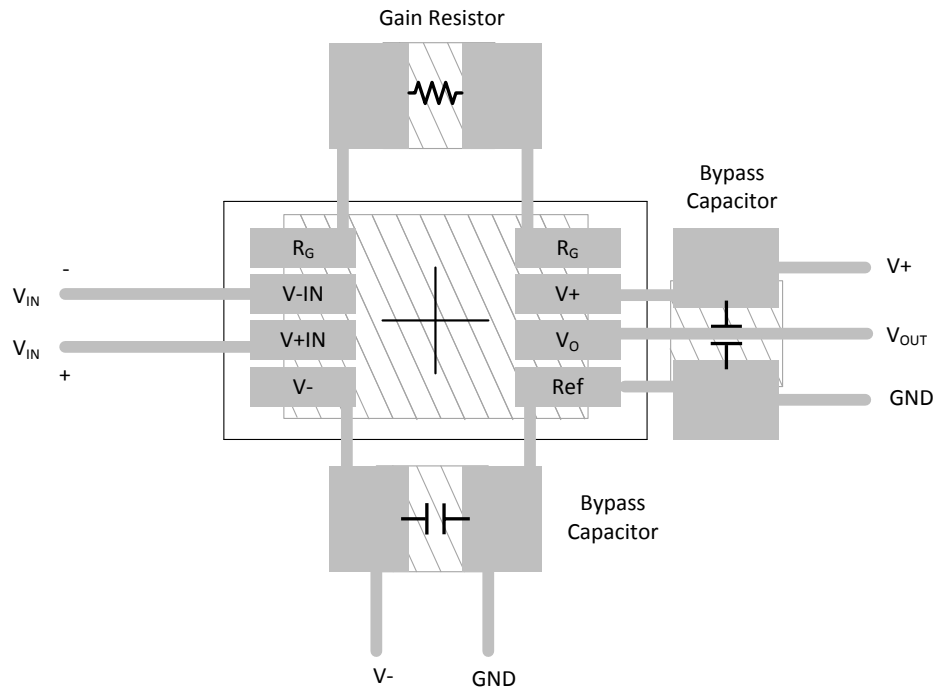

Figure 26. Layout for All Single INA126 Versions

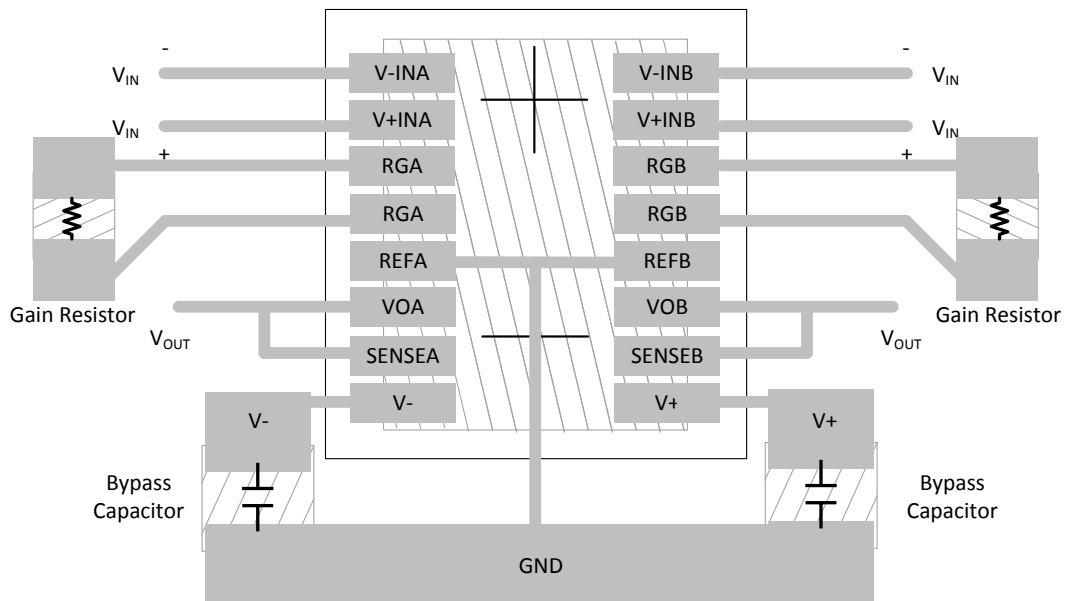

Figure 27. INA2126 Layout

11 Device and Documentation Support

11.1 Related Links

The table below lists quick access links. Categories include technical documents, support and community resources, tools and software, and quick access to sample or buy.

Table 1. Related Links

PARTS	PRODUCT FOLDER	SAMPLE & BUY	TECHNICAL DOCUMENTS	TOOLS & SOFTWARE	SUPPORT & COMMUNITY
INA126	Click here	Click here	Click here	Click here	Click here
INA2126	Click here	Click here	Click here	Click here	Click here

11.2 Community Resources

The following links connect to TI community resources. Linked contents are provided "AS IS" by the respective contributors. They do not constitute TI specifications and do not necessarily reflect TI's views; see TI's [Terms of Use](#).

TI E2E™ Online Community *TI's Engineer-to-Engineer (E2E) Community*. Created to foster collaboration among engineers. At e2e.ti.com, you can ask questions, share knowledge, explore ideas and help solve problems with fellow engineers.

Design Support *TI's Design Support* Quickly find helpful E2E forums along with design support tools and contact information for technical support.

11.3 Trademarks

E2E is a trademark of Texas Instruments.
All other trademarks are the property of their respective owners.

11.4 Electrostatic Discharge Caution



These devices have limited built-in ESD protection. The leads should be shorted together or the device placed in conductive foam during storage or handling to prevent electrostatic damage to the MOS gates.

11.5 Glossary

SLYZ022 — *TI Glossary*.

This glossary lists and explains terms, acronyms, and definitions.

12 Mechanical, Packaging, and Orderable Information

The following pages include mechanical, packaging, and orderable information. This information is the most current data available for the designated devices. This data is subject to change without notice and revision of this document. For browser-based versions of this data sheet, refer to the left-hand navigation.

PACKAGING INFORMATION

Orderable Device	Status (1)	Package Type	Package Drawing	Pins	Package Qty	Eco Plan (2)	Lead/Ball Finish (6)	MSL Peak Temp (3)	Op Temp (°C)	Device Marking (4/5)	Samples
INA126E/250	ACTIVE	VSSOP	DGK	8	250	Green (RoHS & no Sb/Br)	CU NIPDAU CU NIPDAUAG	Level-2-260C-1 YEAR	-55 to 125	A26	Samples
INA126E/250G4	ACTIVE	VSSOP	DGK	8	250	Green (RoHS & no Sb/Br)	CU NIPDAUAG	Level-2-260C-1 YEAR	-55 to 125	A26	Samples
INA126E/2K5	ACTIVE	VSSOP	DGK	8	2500	Green (RoHS & no Sb/Br)	CU NIPDAU CU NIPDAUAG	Level-2-260C-1 YEAR		A26	Samples
INA126E/2K5G4	ACTIVE	VSSOP	DGK	8	2500	Green (RoHS & no Sb/Br)	CU NIPDAUAG	Level-2-260C-1 YEAR		A26	Samples
INA126EA/250	ACTIVE	VSSOP	DGK	8	250	Green (RoHS & no Sb/Br)	CU NIPDAU CU NIPDAUAG	Level-2-260C-1 YEAR		A26	Samples
INA126EA/2K5	ACTIVE	VSSOP	DGK	8	2500	Green (RoHS & no Sb/Br)	CU NIPDAU CU NIPDAUAG	Level-2-260C-1 YEAR		A26	Samples
INA126EA/2K5G4	ACTIVE	VSSOP	DGK	8	2500	Green (RoHS & no Sb/Br)	CU NIPDAUAG	Level-2-260C-1 YEAR		A26	Samples
INA126P	ACTIVE	PDIP	P	8	50	Green (RoHS & no Sb/Br)	CU NIPDAU	N / A for Pkg Type		INA126P	Samples
INA126PA	ACTIVE	PDIP	P	8	50	Green (RoHS & no Sb/Br)	CU NIPDAU	N / A for Pkg Type		INA126P A	Samples
INA126U	ACTIVE	SOIC	D	8	75	Green (RoHS & no Sb/Br)	CU NIPDAU	Level-3-260C-168 HR		INA 126U	Samples
INA126U/2K5	ACTIVE	SOIC	D	8	2500	Green (RoHS & no Sb/Br)	CU NIPDAU	Level-3-260C-168 HR		INA 126U	Samples
INA126U/2K5G4	ACTIVE	SOIC	D	8	2500	Green (RoHS & no Sb/Br)	CU NIPDAU	Level-3-260C-168 HR		INA 126U	Samples
INA126UA	ACTIVE	SOIC	D	8	75	Green (RoHS & no Sb/Br)	CU NIPDAU	Level-3-260C-168 HR		INA 126U A	Samples
INA126UA/2K5	ACTIVE	SOIC	D	8	2500	Green (RoHS & no Sb/Br)	CU NIPDAU	Level-3-260C-168 HR		INA 126U A	Samples
INA126UAG4	ACTIVE	SOIC	D	8	75	Green (RoHS & no Sb/Br)	CU NIPDAU	Level-3-260C-168 HR		INA 126U A	Samples
INA2126E/250	ACTIVE	SSOP	DBQ	16	250	Green (RoHS & no Sb/Br)	Call TI	Level-3-260C-168 HR		INA 2126E	Samples

Orderable Device	Status (1)	Package Type	Package Drawing	Pins	Package Qty	Eco Plan (2)	Lead/Ball Finish (6)	MSL Peak Temp (3)	Op Temp (°C)	Device Marking (4/5)	Samples
										A	
INA2126E/250G4	ACTIVE	SSOP	DBQ	16	250	Green (RoHS & no Sb/Br)	Call TI	Level-3-260C-168 HR		INA 2126E A	Samples
INA2126E/2K5	ACTIVE	SSOP	DBQ	16	2500	Green (RoHS & no Sb/Br)	Call TI	Level-3-260C-168 HR		INA 2126E A	Samples
INA2126EA/250	ACTIVE	SSOP	DBQ	16	250	Green (RoHS & no Sb/Br)	Call TI	Level-3-260C-168 HR		INA 2126E A	Samples
INA2126EA/250G4	ACTIVE	SSOP	DBQ	16	250	Green (RoHS & no Sb/Br)	Call TI	Level-3-260C-168 HR		INA 2126E A	Samples
INA2126EA/2K5	ACTIVE	SSOP	DBQ	16	2500	Green (RoHS & no Sb/Br)	Call TI	Level-3-260C-168 HR		INA 2126E A	Samples
INA2126U	ACTIVE	SOIC	D	16	40	Green (RoHS & no Sb/Br)	CU NIPDAU	Level-3-260C-168 HR		INA2126U	Samples
INA2126UA	ACTIVE	SOIC	D	16	40	Green (RoHS & no Sb/Br)	CU NIPDAU	Level-3-260C-168 HR	-40 to 85	INA2126U A	Samples
INA2126UA/2K5	ACTIVE	SOIC	D	16	2500	Green (RoHS & no Sb/Br)	CU NIPDAU	Level-3-260C-168 HR	-40 to 85	INA2126U A	Samples
INA2126UE4	ACTIVE	SOIC	D	16	40	Green (RoHS & no Sb/Br)	CU NIPDAU	Level-3-260C-168 HR		INA2126U	Samples

(1) The marketing status values are defined as follows:

ACTIVE: Product device recommended for new designs.

LIFEBUY: TI has announced that the device will be discontinued, and a lifetime-buy period is in effect.

NRND: Not recommended for new designs. Device is in production to support existing customers, but TI does not recommend using this part in a new design.

PREVIEW: Device has been announced but is not in production. Samples may or may not be available.

OBSELETE: TI has discontinued the production of the device.

(2) **RoHS:** TI defines "RoHS" to mean semiconductor products that are compliant with the current EU RoHS requirements for all 10 RoHS substances, including the requirement that RoHS substance do not exceed 0.1% by weight in homogeneous materials. Where designed to be soldered at high temperatures, "RoHS" products are suitable for use in specified lead-free processes. TI may reference these types of products as "Pb-Free".

RoHS Exempt: TI defines "RoHS Exempt" to mean products that contain lead but are compliant with EU RoHS pursuant to a specific EU RoHS exemption.

Green: TI defines "Green" to mean the content of Chlorine (Cl) and Bromine (Br) based flame retardants meet JS709B low halogen requirements of <=1000ppm threshold. Antimony trioxide based flame retardants must also meet the <=1000ppm threshold requirement.

- (3) MSL, Peak Temp. - The Moisture Sensitivity Level rating according to the JEDEC industry standard classifications, and peak solder temperature.
- (4) There may be additional marking, which relates to the logo, the lot trace code information, or the environmental category on the device.
- (5) Multiple Device Markings will be inside parentheses. Only one Device Marking contained in parentheses and separated by a "~" will appear on a device. If a line is indented then it is a continuation of the previous line and the two combined represent the entire Device Marking for that device.
- (6) Lead/Ball Finish - Orderable Devices may have multiple material finish options. Finish options are separated by a vertical ruled line. Lead/Ball Finish values may wrap to two lines if the finish value exceeds the maximum column width.

Important Information and Disclaimer:The information provided on this page represents TI's knowledge and belief as of the date that it is provided. TI bases its knowledge and belief on information provided by third parties, and makes no representation or warranty as to the accuracy of such information. Efforts are underway to better integrate information from third parties. TI has taken and continues to take reasonable steps to provide representative and accurate information but may not have conducted destructive testing or chemical analysis on incoming materials and chemicals. TI and TI suppliers consider certain information to be proprietary, and thus CAS numbers and other limited information may not be available for release.

In no event shall TI's liability arising out of such information exceed the total purchase price of the TI part(s) at issue in this document sold by TI to Customer on an annual basis.

TAPE AND REEL INFORMATION

QUADRANT ASSIGNMENTS FOR PIN 1 ORIENTATION IN TAPE

*All dimensions are nominal

Device	Package Type	Package Drawing	Pins	SPQ	Reel Diameter (mm)	Reel Width W1 (mm)	A0 (mm)	B0 (mm)	K0 (mm)	P1 (mm)	W (mm)	Pin1 Quadrant
INA126E/250	VSSOP	DGK	8	250	180.0	12.4	5.3	3.4	1.4	8.0	12.0	Q1
INA126E/2K5	VSSOP	DGK	8	2500	330.0	12.4	5.3	3.4	1.4	8.0	12.0	Q1
INA126EA/250	VSSOP	DGK	8	250	180.0	12.4	5.3	3.4	1.4	8.0	12.0	Q1
INA126EA/2K5	VSSOP	DGK	8	2500	330.0	12.4	5.3	3.4	1.4	8.0	12.0	Q1
INA126U/2K5	SOIC	D	8	2500	330.0	12.4	6.4	5.2	2.1	8.0	12.0	Q1
INA126UA/2K5	SOIC	D	8	2500	330.0	12.4	6.4	5.2	2.1	8.0	12.0	Q1
INA2126E/250	SSOP	DBQ	16	250	180.0	12.4	6.4	5.2	2.1	8.0	12.0	Q1
INA2126E/2K5	SSOP	DBQ	16	2500	330.0	12.4	6.4	5.2	2.1	8.0	12.0	Q1
INA2126EA/250	SSOP	DBQ	16	250	180.0	12.4	6.4	5.2	2.1	8.0	12.0	Q1
INA2126EA/2K5	SSOP	DBQ	16	2500	330.0	12.4	6.4	5.2	2.1	8.0	12.0	Q1
INA2126UA/2K5	SOIC	D	16	2500	330.0	16.4	6.5	10.3	2.1	8.0	16.0	Q1

TAPE AND REEL BOX DIMENSIONS

*All dimensions are nominal

Device	Package Type	Package Drawing	Pins	SPQ	Length (mm)	Width (mm)	Height (mm)
INA126E/250	VSSOP	DGK	8	250	210.0	185.0	35.0
INA126E/2K5	VSSOP	DGK	8	2500	367.0	367.0	35.0
INA126EA/250	VSSOP	DGK	8	250	210.0	185.0	35.0
INA126EA/2K5	VSSOP	DGK	8	2500	367.0	367.0	35.0
INA126U/2K5	SOIC	D	8	2500	367.0	367.0	35.0
INA126UA/2K5	SOIC	D	8	2500	367.0	367.0	35.0
INA2126E/250	SSOP	DBQ	16	250	210.0	185.0	35.0
INA2126E/2K5	SSOP	DBQ	16	2500	367.0	367.0	35.0
INA2126EA/250	SSOP	DBQ	16	250	210.0	185.0	35.0
INA2126EA/2K5	SSOP	DBQ	16	2500	367.0	367.0	35.0
INA2126UA/2K5	SOIC	D	16	2500	367.0	367.0	38.0

D (R-PDSO-G16)

PLASTIC SMALL OUTLINE



4040047-6/M 06/11

- NOTES:
- A. All linear dimensions are in inches (millimeters).
 - B. This drawing is subject to change without notice.
 -  C. Body length does not include mold flash, protrusions, or gate burrs. Mold flash, protrusions, or gate burrs shall not exceed 0.006 (0,15) each side.
 -  D. Body width does not include interlead flash. Interlead flash shall not exceed 0.017 (0,43) each side.
 - E. Reference JEDEC MS-012 variation AC.

D (R-PDSO-G16)

PLASTIC SMALL OUTLINE



- NOTES:
- All linear dimensions are in millimeters.
 - This drawing is subject to change without notice.
 - Publication IPC-7351 is recommended for alternate designs.
 - Laser cutting apertures with trapezoidal walls and also rounding corners will offer better paste release. Customers should contact their board assembly site for stencil design recommendations. Refer to IPC-7525 for other stencil recommendations.
 - Customers should contact their board fabrication site for solder mask tolerances between and around signal pads.



D0008A

PACKAGE OUTLINE

SOIC - 1.75 mm max height

SMALL OUTLINE INTEGRATED CIRCUIT



4214825/C 02/2019

NOTES:

- Linear dimensions are in inches [millimeters]. Dimensions in parenthesis are for reference only. Controlling dimensions are in inches. Dimensioning and tolerancing per ASME Y14.5M.
- This drawing is subject to change without notice.
- This dimension does not include mold flash, protrusions, or gate burrs. Mold flash, protrusions, or gate burrs shall not exceed $.006$ [0.15] per side.
- This dimension does not include interlead flash.
- Reference JEDEC registration MS-012, variation AA.

EXAMPLE BOARD LAYOUT

D0008A

SOIC - 1.75 mm max height

SMALL OUTLINE INTEGRATED CIRCUIT



LAND PATTERN EXAMPLE
 EXPOSED METAL SHOWN
 SCALE:8X



SOLDER MASK DETAILS

4214825/C 02/2019

NOTES: (continued)

- 6. Publication IPC-7351 may have alternate designs.
- 7. Solder mask tolerances between and around signal pads can vary based on board fabrication site.

EXAMPLE STENCIL DESIGN

D0008A

SOIC - 1.75 mm max height

SMALL OUTLINE INTEGRATED CIRCUIT



SOLDER PASTE EXAMPLE
BASED ON .005 INCH [0.125 MM] THICK STENCIL
SCALE:8X

4214825/C 02/2019

NOTES: (continued)

8. Laser cutting apertures with trapezoidal walls and rounded corners may offer better paste release. IPC-7525 may have alternate design recommendations.
9. Board assembly site may have different recommendations for stencil design.

GENERIC PACKAGE VIEW

DBQ 16

SSOP - 1.75 mm max height

SHRINK SMALL-OUTLINE PACKAGE

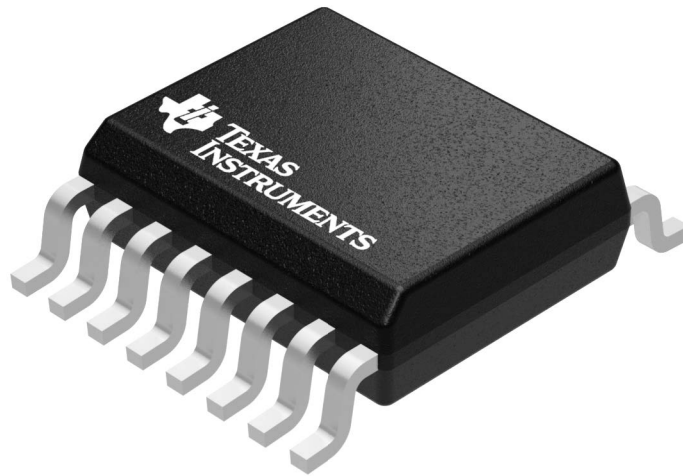

Images above are just a representation of the package family, actual package may vary.
Refer to the product data sheet for package details.

4073301-2/1

P (R-PDIP-T8)

PLASTIC DUAL-IN-LINE PACKAGE



- NOTES:
- A. All linear dimensions are in inches (millimeters).
 - B. This drawing is subject to change without notice.
 - C. Falls within JEDEC MS-001 variation BA.

DGK (S-PDSO-G8)

PLASTIC SMALL-OUTLINE PACKAGE

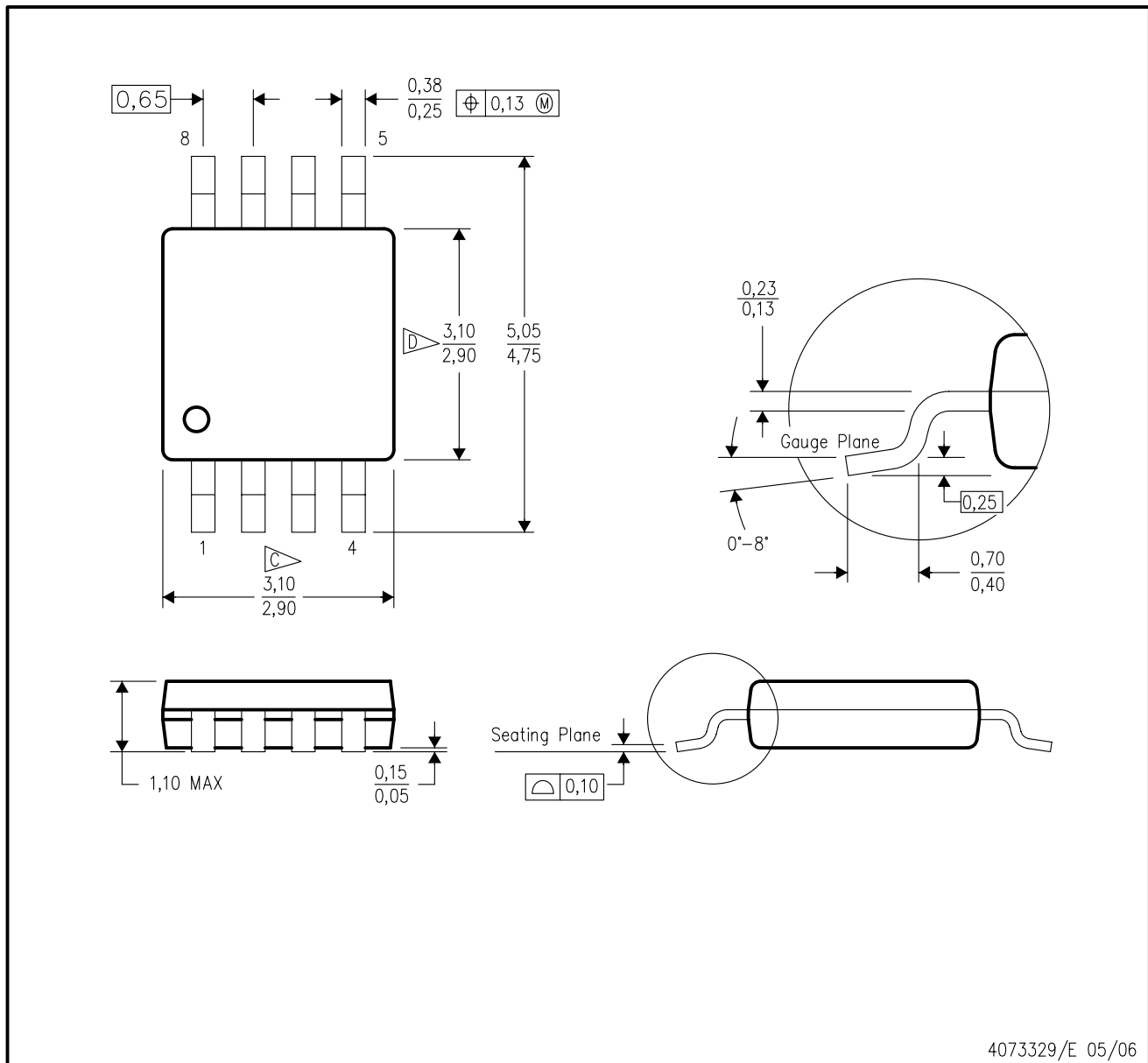

- NOTES:
- A. All linear dimensions are in millimeters.
 - B. This drawing is subject to change without notice.
 - C. Body length does not include mold flash, protrusions, or gate burrs. Mold flash, protrusions, or gate burrs shall not exceed 0.15 per end.
 - D. Body width does not include interlead flash. Interlead flash shall not exceed 0.50 per side.
 - E. Falls within JEDEC MO-187 variation AA, except interlead flash.



- NOTES:
- A. All linear dimensions are in millimeters.
 - B. This drawing is subject to change without notice.
 - C. Publication IPC-7351 is recommended for alternate designs.
 - D. Laser cutting apertures with trapezoidal walls and also rounding corners will offer better paste release. Customers should contact their board assembly site for stencil design recommendations. Refer to IPC-7525 for other stencil recommendations.
 - E. Customers should contact their board fabrication site for solder mask tolerances between and around signal pads.

IMPORTANT NOTICE AND DISCLAIMER

TI PROVIDES TECHNICAL AND RELIABILITY DATA (INCLUDING DATASHEETS), DESIGN RESOURCES (INCLUDING REFERENCE DESIGNS), APPLICATION OR OTHER DESIGN ADVICE, WEB TOOLS, SAFETY INFORMATION, AND OTHER RESOURCES "AS IS" AND WITH ALL FAULTS, AND DISCLAIMS ALL WARRANTIES, EXPRESS AND IMPLIED, INCLUDING WITHOUT LIMITATION ANY IMPLIED WARRANTIES OF MERCHANTABILITY, FITNESS FOR A PARTICULAR PURPOSE OR NON-INFRINGEMENT OF THIRD PARTY INTELLECTUAL PROPERTY RIGHTS.

These resources are intended for skilled developers designing with TI products. You are solely responsible for (1) selecting the appropriate TI products for your application, (2) designing, validating and testing your application, and (3) ensuring your application meets applicable standards, and any other safety, security, or other requirements. These resources are subject to change without notice. TI grants you permission to use these resources only for development of an application that uses the TI products described in the resource. Other reproduction and display of these resources is prohibited. No license is granted to any other TI intellectual property right or to any third party intellectual property right. TI disclaims responsibility for, and you will fully indemnify TI and its representatives against, any claims, damages, costs, losses, and liabilities arising out of your use of these resources.

TI's products are provided subject to TI's Terms of Sale (www.ti.com/legal/termsofsale.html) or other applicable terms available either on ti.com or provided in conjunction with such TI products. TI's provision of these resources does not expand or otherwise alter TI's applicable warranties or warranty disclaimers for TI products.

Mailing Address: Texas Instruments, Post Office Box 655303, Dallas, Texas 75265
Copyright © 2019, Texas Instruments Incorporated

Looking for pricing, stock, or lifecycle information?

Click below to explore more details on WIN SOURCE:

 [View INA126UA/2K5 on WIN SOURCE](#)

 [Texas Instruments](#) Information

Optimize Your Supply Chain with WIN SOURCE Solutions

-  Global Sourcing Solution
-  Obsolete Management
-  Cost Control Management
-  Shortage Management
-  Alternative Solution
-  Excess Inventory Management