





INA115

# Precision INSTRUMENTATION AMPLIFIER

## FEATURES

- LOW OFFSET VOLTAGE: 50µV max
- LOW DRIFT: 0.25µV/°C max
- LOW INPUT BIAS CURRENT: 2nA max
- HIGH COMMON-MODE REJECTION: 115dB min
- INPUT OVER-VOLTAGE PROTECTION: ±40V
- WIDE SUPPLY RANGE: ±2.25 TO ±18V
- LOW QUIESCENT CURRENT: 3mA max
- SOL-16 SURFACE-MOUNT PACKAGE

## APPLICATIONS

- SWITCHED-GAIN AMPLIFIER
- BRIDGE AMPLIFIER
- THERMOCOUPLE AMPLIFIER
- RTD SENSOR AMPLIFIER
- MEDICAL INSTRUMENTATION
- DATA ACQUISITION

## DESCRIPTION

The INA115 is a low cost, general purpose instrumentation amplifier offering excellent accuracy. Its versatile three-op amp design and small size make it ideal for a wide range of applications. Similar to the model INA114, the INA115 provides additional connections to the input op amps, A<sub>1</sub> and A<sub>2</sub>, which improve gain accuracy in high gains and are useful in forming switched-gain amplifiers.

A single external resistor sets any gain from 1 to 10,000. Internal input protection can withstand up to ±40V without damage.

The INA115 is laser trimmed for very low offset voltage (50µV), drift (0.25µV/°C) and high common-mode rejection (115dB at G=1000). It operates with power supplies as low as ±2.25V, allowing use in battery operated and single 5V supply systems. Quiescent current is 3mA maximum.

The INA115 is available in the SOL-16 surface-mount package, specified for the -40°C to +85°C temperature range.

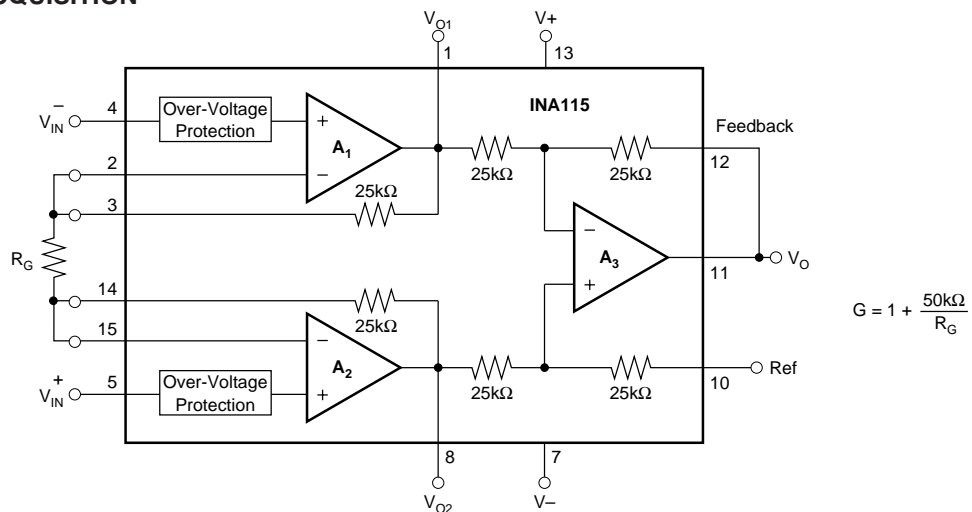

International Airport Industrial Park • Mailing Address: PO Box 11400, Tucson, AZ 85734 • Street Address: 6730 S. Tucson Blvd., Tucson, AZ 85706 • Tel: (520) 746-1111 • Twx: 910-952-1111  
 Internet: <http://www.burr-brown.com/> • FAXLine: (800) 548-6133 (US/Canada Only) • Cable: BBRCORP • Telex: 066-6491 • FAX: (520) 889-1510 • Immediate Product Info: (800) 548-6132

# SPECIFICATIONS

## ELECTRICAL

At  $T_A = +25^\circ\text{C}$ ,  $V_S = \pm 15\text{V}$ ,  $R_L = 2\text{k}\Omega$  unless otherwise noted.

PARAMETER	CONDITIONS	INA115BU			INA115AU			UNITS	
		MIN	TYP	MAX	MIN	TYP	MAX		
<b>INPUT</b> Offset Voltage, RTI Initial vs Temperature vs Power Supply Long-Term Stability Impedance, Differential Common-Mode Input Common-Mode Range Safe Input Voltage Common-Mode Rejection	$T_A = +25^\circ\text{C}$ $T_A = T_{\text{MIN}}$ to $T_{\text{MAX}}$ $V_S = \pm 2.25\text{V}$ to $\pm 18\text{V}$  $V_{\text{CM}} = \pm 10\text{V}$ , $\Delta R_S = 1\text{k}\Omega$ G = 1 G = 10 G = 100 G = 1000		$\pm 10 + 20/\text{G}$ $\pm 0.1 + 0.5/\text{G}$ $0.5 + 2/\text{G}$ $\pm 0.2 + 0.5/\text{G}$ $10^{10} \parallel 6$ $10^{10} \parallel 6$ $\pm 13.5$	$\pm 50 + 100/\text{G}$ $\pm 0.25 + 5/\text{G}$ $3 + 10/\text{G}$		$\pm 25 + 30/\text{G}$ $\pm 0.25 + 5/\text{G}$ * * * * *	$\pm 125 + 500/\text{G}$ $\pm 1 + 10/\text{G}$ * * * * *	$\mu\text{V}$ $\mu\text{V}/^\circ\text{C}$ $\mu\text{V}/\text{V}$ $\mu\text{V}/\text{mo}$ $\Omega \parallel \text{pF}$ $\Omega \parallel \text{pF}$ V V	
			80	96		75	90		dB
			96	115		90	106		dB
			110	120		106	110		dB
			115	120		106	110		dB
<b>BIAS CURRENT</b> vs Temperature			$\pm 0.5$ $\pm 8$	$\pm 2$		* *	$\pm 5$	nA $\text{pA}/^\circ\text{C}$	
<b>OFFSET CURRENT</b> vs Temperature			$\pm 0.5$ $\pm 8$	$\pm 2$		* *	$\pm 5$	nA $\text{pA}/^\circ\text{C}$	
<b>NOISE VOLTAGE, RTI</b> f = 10Hz f = 100Hz f = 1kHz f <sub>B</sub> = 0.1Hz to 10Hz Noise Current f=10Hz f=1kHz f <sub>B</sub> = 0.1Hz to 10Hz	G = 1000, R <sub>S</sub> = 0Ω		15 11 11 0.4			* * * *		$\text{nV}/\sqrt{\text{Hz}}$ $\text{nV}/\sqrt{\text{Hz}}$ $\text{nV}/\sqrt{\text{Hz}}$ $\mu\text{Vp-p}$	
			0.4			* * *		$\text{pA}/\sqrt{\text{Hz}}$ $\text{pA}/\sqrt{\text{Hz}}$ $\text{pAp-p}$	
<b>GAIN</b> Gain Equation Range of Gain Gain Error  Gain vs Temperature 50kΩ Resistance <sup>(1)</sup> Nonlinearity	G = 1 G = 10 G = 100 G = 1000 G = 1 G = 1 G = 10 G = 100 G = 1000	1	$1 + (50\text{k}\Omega/R_G)$	10000	*	*	*	V/V V/V % % % %	
			$\pm 0.01$ $\pm 0.02$ $\pm 0.05$ $\pm 0.5$ $\pm 1$	$\pm 0.05$ $\pm 0.4$ $\pm 0.5$ $\pm 1$ $\pm 10$		* * * * *	$\pm 0.5$ $\pm 0.7$ $\pm 2$ $\pm 10$	ppm/ $^\circ\text{C}$ ppm/ $^\circ\text{C}$ % of FSR % of FSR % of FSR	
			$\pm 25$ $\pm 0.0001$ $\pm 0.0005$ $\pm 0.0005$ $\pm 0.002$	$\pm 100$ $\pm 0.001$ $\pm 0.002$ $\pm 0.002$ $\pm 0.01$		* * * * *	$\pm 0.002$ $\pm 0.004$ $\pm 0.004$ $\pm 0.02$	% of FSR % of FSR % of FSR % of FSR	
<b>OUTPUT<sup>(2)</sup></b> Voltage  Load Capacitance Stability Short Circuit Current	$I_O = 5\text{mA}$ , $T_{\text{MIN}}$ to $T_{\text{MAX}}$ $V_S = \pm 11.4\text{V}$ , $R_L = 2\text{k}\Omega$ $V_S = \pm 2.25\text{V}$ , $R_L = 2\text{k}\Omega$	$\pm 13.5$	$\pm 13.7$ $\pm 10.5$		* *	* *		V V V	
		$\pm 1$	$\pm 1.5$ 1000		* *	* *		pF mA	
			+200/-15		* *	* *			
<b>FREQUENCY RESPONSE</b> Bandwidth, -3dB  Slew Rate Settling Time, 0.01%  Overload Recovery	G = 1 G = 10 G = 100 G = 1000 $V_O = \pm 10\text{V}$ , G = 10 G = 1 G = 10 G = 100 G = 1000 50% Overdrive		1 100 10 1			* * * *		MHz kHz kHz kHz	
			0.3	0.6 18 20 120 1100 20		* * * * * *		V/ $\mu\text{s}$ $\mu\text{s}$ $\mu\text{s}$ $\mu\text{s}$ $\mu\text{s}$ $\mu\text{s}$	
<b>POWER SUPPLY</b> Voltage Range Current	$V_{\text{IN}} = 0\text{V}$	$\pm 2.25$	$\pm 15$ $\pm 2.2$	$\pm 18$ $\pm 3$	* *	* *	* *	V mA	
<b>TEMPERATURE RANGE</b> Specification Operating $\theta_{\text{JA}}$		-40		+85	* *		* *	$^\circ\text{C}$ $^\circ\text{C}$ $^\circ\text{C}/\text{W}$	
				+125					
			80						

\* Specification same as INA115BU.

NOTE: (1) Temperature coefficient of the "50kΩ" term in the gain equation. (2) Output specifications are for output amplifier, A<sub>3</sub>. A<sub>1</sub> and A<sub>2</sub> provide the same output voltage swing but have less output current drive. A<sub>1</sub> and A<sub>2</sub> can drive external loads of 25kΩ || 200pF.

## PIN CONFIGURATIONS

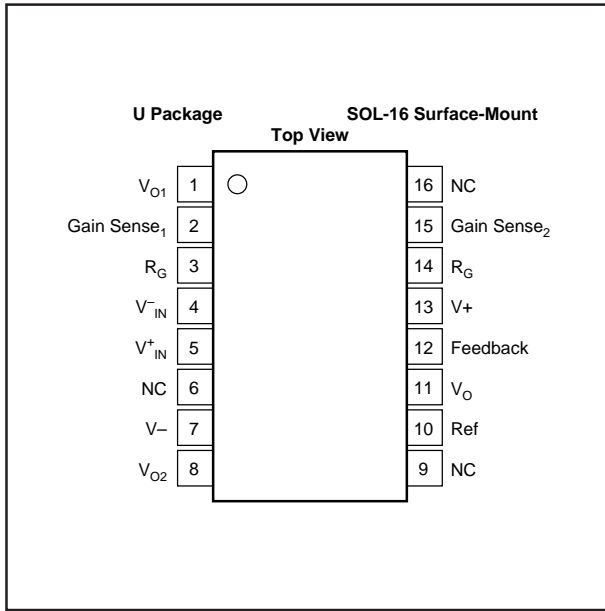

## ELECTROSTATIC DISCHARGE SENSITIVITY

This integrated circuit can be damaged by ESD. Burr-Brown recommends that all integrated circuits be handled with appropriate precautions. Failure to observe proper handling and installation procedures can cause damage.

ESD damage can range from subtle performance degradation to complete device failure. Precision integrated circuits may be more susceptible to damage because very small parametric changes could cause the device not to meet its published specifications.

### ABSOLUTE MAXIMUM RATINGS

Supply Voltage .....	±18V
Input Voltage Range .....	±40V
Output Short-Circuit (to ground) .....	Continuous
Operating Temperature .....	-40°C to +125°C
Storage Temperature .....	-40°C to +125°C
Junction Temperature .....	+150°C
Lead Temperature (soldering, 10s) .....	+300°C

## PACKAGE/ORDERING INFORMATION

PRODUCT	PACKAGE	PACKAGE DRAWING NUMBER <sup>(1)</sup>	TEMPERATURE RANGE
INA115AU	SOL-16 Surface-Mount	211	-40°C to +85°C
INA115BU	SOL-16 Surface-Mount	211	-40°C to +85°C

NOTE: (1) For detailed drawing and dimension table, please see end of data sheet, or Appendix C of Burr-Brown IC Data Book.

The information provided herein is believed to be reliable; however, BURR-BROWN assumes no responsibility for inaccuracies or omissions. BURR-BROWN assumes no responsibility for the use of this information, and all use of such information shall be entirely at the user's own risk. Prices and specifications are subject to change without notice. No patent rights or licenses to any of the circuits described herein are implied or granted to any third party. BURR-BROWN does not authorize or warrant any BURR-BROWN product for use in life support devices and/or systems.

# TYPICAL PERFORMANCE CURVES

At  $T_A = +25^\circ\text{C}$ ,  $V_S = \pm 15\text{V}$ , unless otherwise noted.

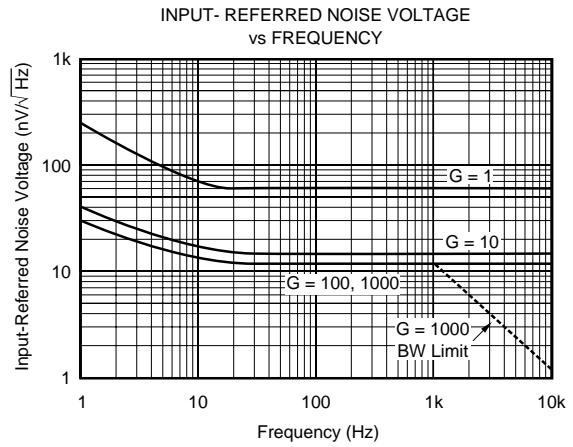
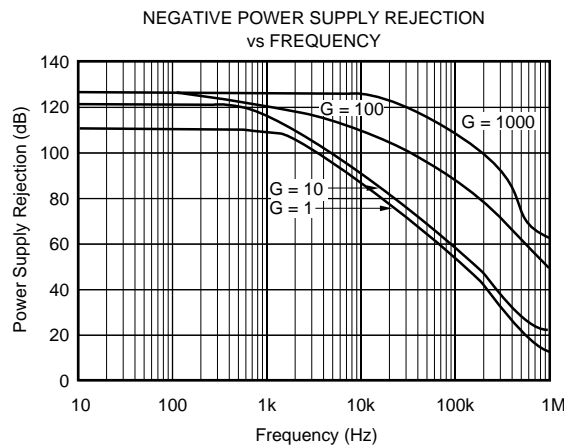
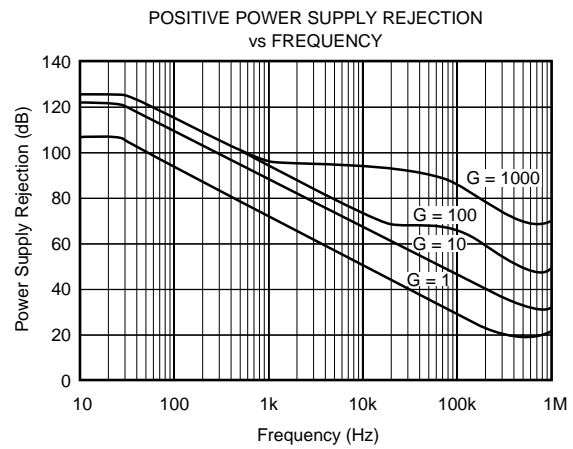
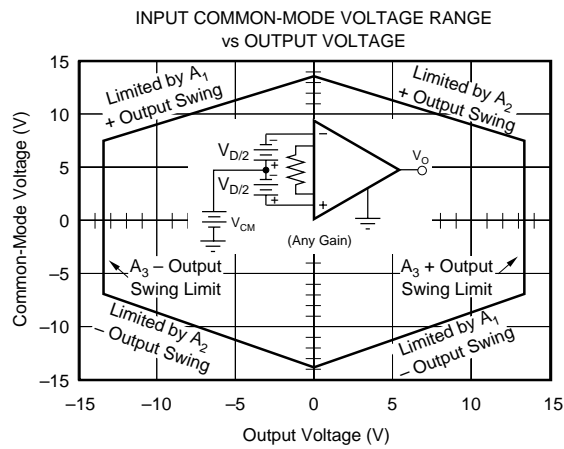
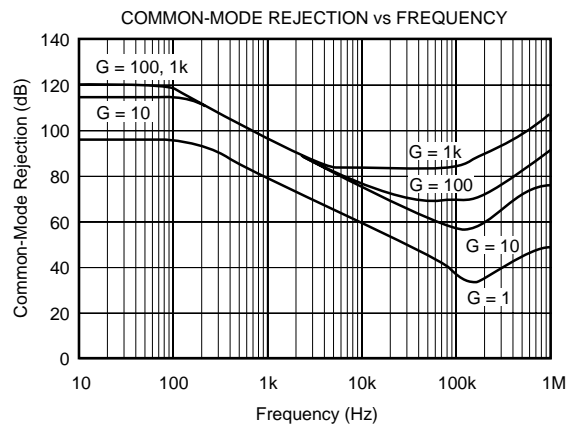
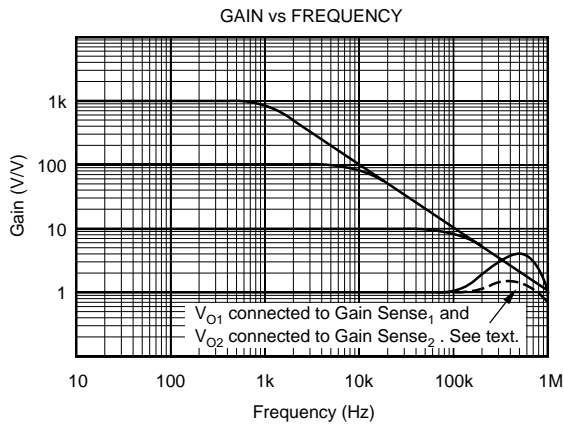

# TYPICAL PERFORMANCE CURVES (CONT)

At  $T_A = +25^\circ\text{C}$ ,  $V_S = \pm 15\text{V}$ , unless otherwise noted.

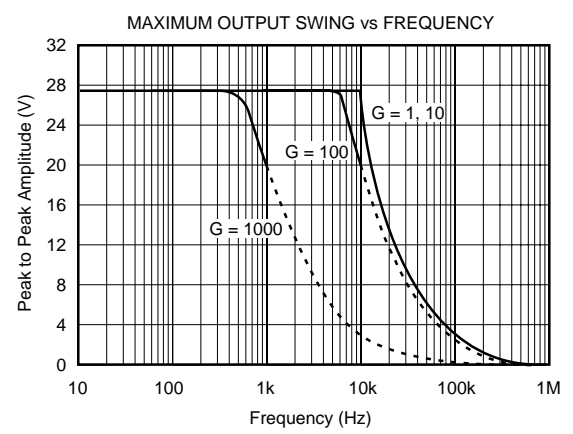
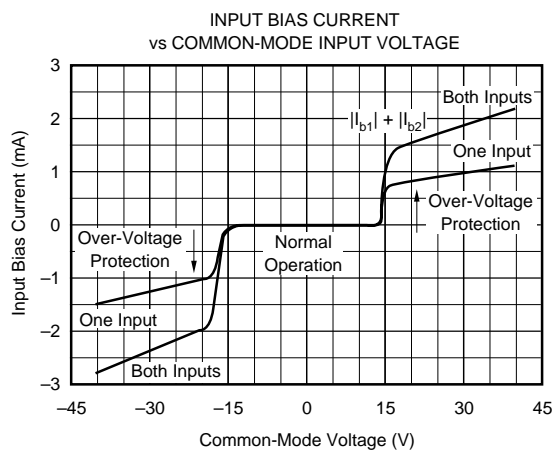
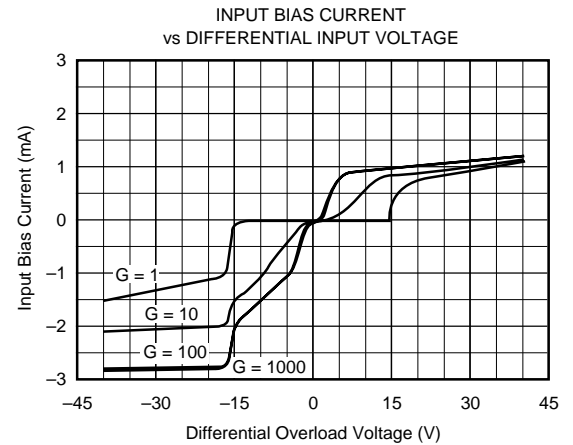
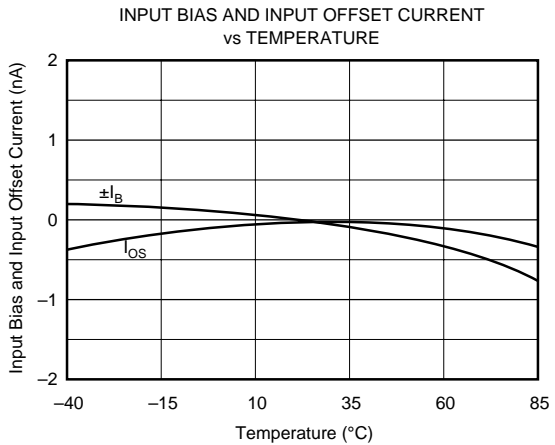
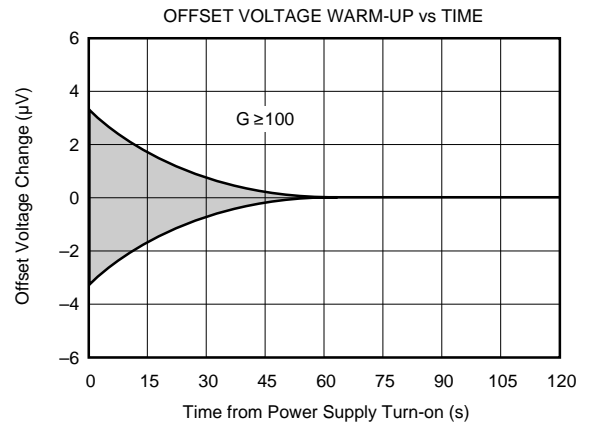
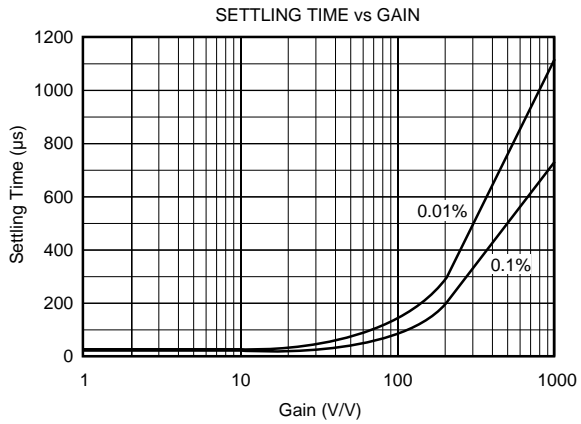

# TYPICAL PERFORMANCE CURVES (CONT)

At  $T_A = +25^\circ\text{C}$ ,  $V_S = \pm 15\text{V}$ , unless otherwise noted.

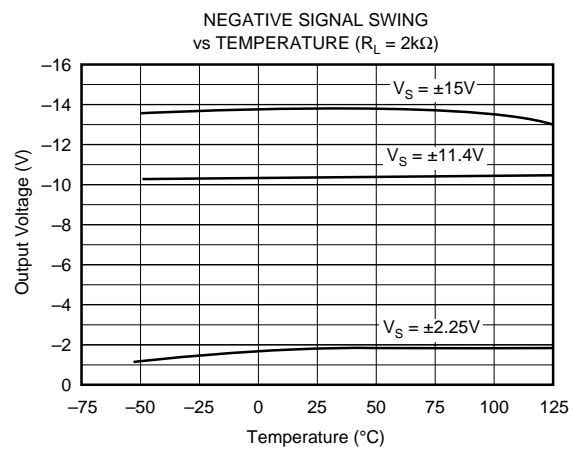
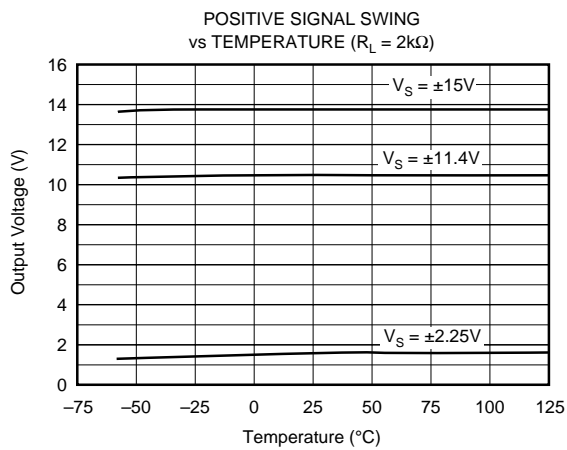
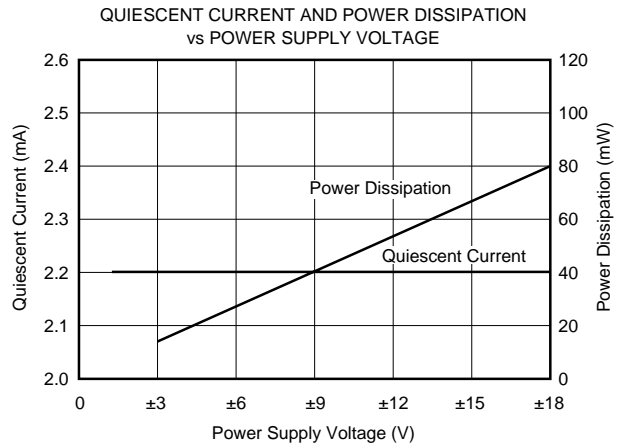
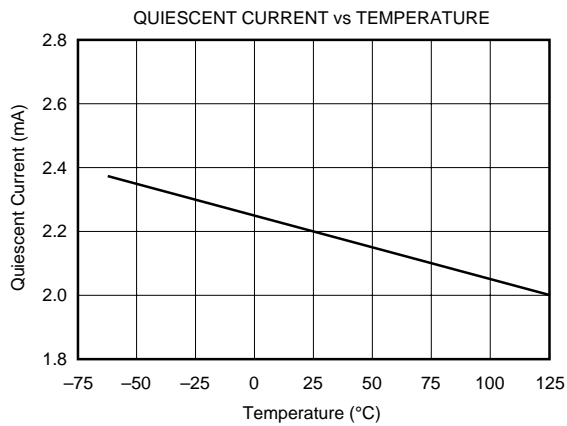
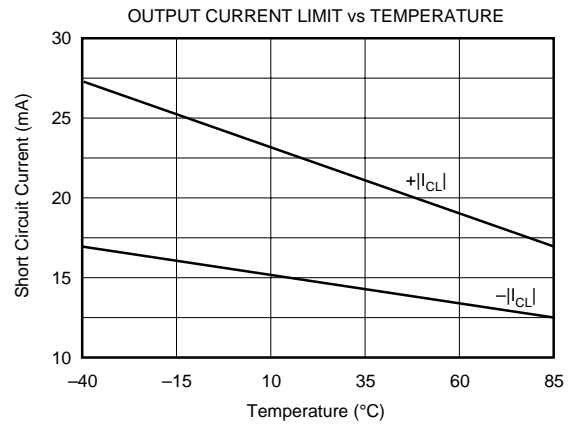
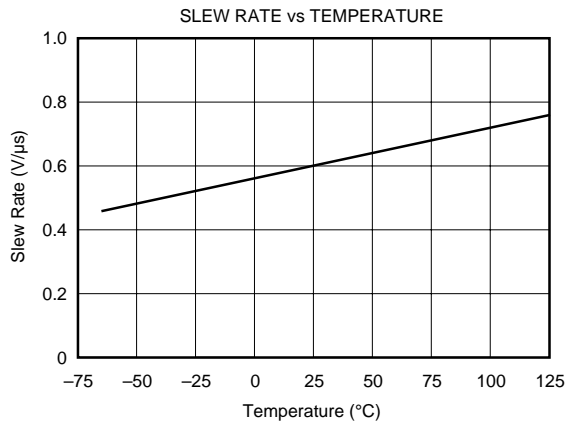

# TYPICAL PERFORMANCE CURVES (CONT)

At  $T_A = +25^\circ\text{C}$ ,  $V_S = \pm 15\text{V}$ , unless otherwise noted.

LARGE SIGNAL RESPONSE,  $G = 1$

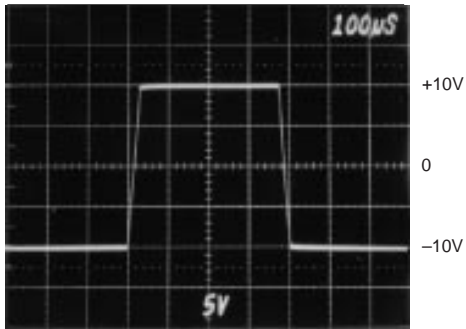

SMALL SIGNAL RESPONSE,  $G = 1$

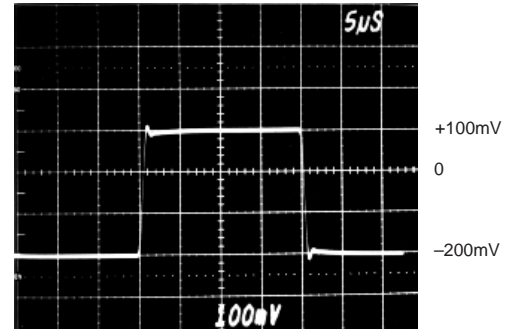

$V_{O1}$  connected to Gain Sense<sub>1</sub>, and  
 $V_{O2}$  connected to Gain Sense<sub>2</sub>

LARGE SIGNAL RESPONSE,  $G = 1000$

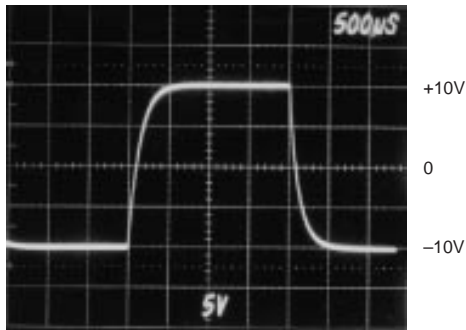

SMALL SIGNAL RESPONSE,  $G = 1000$

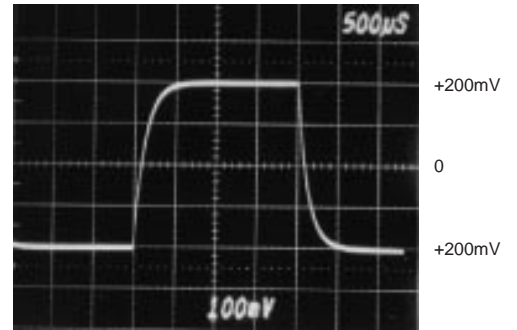

INPUT-REFERRED NOISE, 0.1 to 10Hz

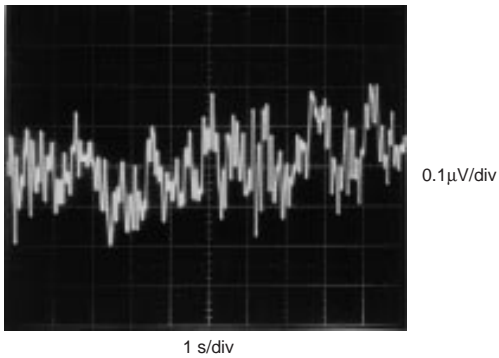

# APPLICATION INFORMATION

Figure 1 shows the basic connections required for operation of the INA115. Applications with noisy or high impedance power supplies may require decoupling capacitors close to the device pins as shown.

The output is referred to the output reference (Ref) terminal which is normally grounded. This must be a low-impedance connection to assure good common-mode rejection. A resistance of 5Ω in series with the Ref pin will cause a typical device to degrade to approximately 80dB CMR (G=1).

The INA115 has a separate output sense feedback connection (pin 12). Pin 12 must be connected (normally to the output terminal, pin 11) for proper operation. The output sense connection can be used to sense the output voltage directly at the load for best accuracy.

## SETTING THE GAIN

Gain of the INA115 is set by connecting a single external resistor,  $R_G$ :

$$G = 1 + \frac{50 \text{ k}\Omega}{R_G} \quad (1)$$

Commonly used gains and resistor values are shown in Figure 1.

For  $G=1$ , no resistor is required, but connect pins 2-3 and connect pins 14-15. Gain peaking in  $G=1$  can be reduced by shorting the internal 25kΩ feedback resistors (see typical performance curve Gain vs Frequency). To do this, connect pins 1-2-3 and connect pins 8-14-15.

The 50kΩ term in equation 1 comes from the sum of the two internal feedback resistors. These are on-chip metal film resistors which are laser trimmed to accurate absolute values. The accuracy and temperature coefficient of these resistors are included in the gain accuracy and drift specifications of the INA115.

The stability and temperature drift of the external gain setting resistor,  $R_G$ , also affects gain.  $R_G$ 's contribution to gain error and drift can be directly inferred from the gain equation (1). Low resistor values required for high gain can make wiring resistance important. The “force and sense” type connections illustrated in Figure 1 help reduce the effect of interconnection resistance.

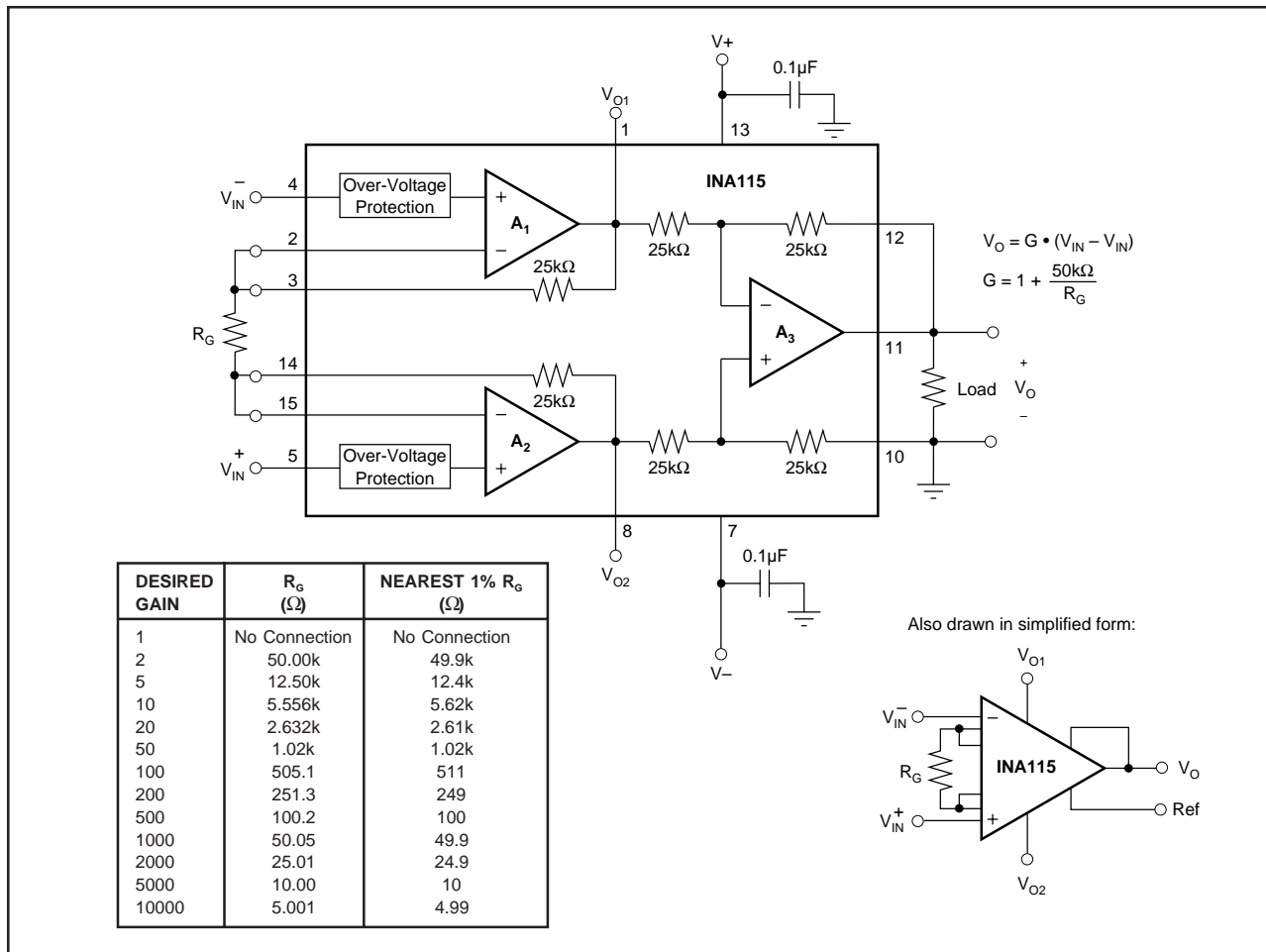

FIGURE 1. Basic Connections.

## SWITCHED GAIN

Figure 2 shows a circuit for digital selection of four gains. Multiplexer “on” resistance does not significantly affect gain. The resistor values required for some commonly used gain steps are shown. This circuit uses the internal 25kΩ feedback resistors, so the resistor values shown cannot be scaled to a different impedance level.

Figure 3 shows an alternative switchable gain configuration. This circuit does not use the internal 25kΩ feedback resistors, so the nominal values shown can be scaled to other impedance levels. This circuit is ideal for use with a precision resistor network to achieve excellent gain accuracy and lowest gain drift.

## NOISE PERFORMANCE

The INA115 provides very low noise in most applications. For differential source impedances less than 1kΩ, the INA103 may provide lower noise. For source impedances greater than 50kΩ, the INA111 FET-Input Instrumentation Amplifier may provide lower noise.

Low frequency noise of the INA115 is approximately 0.4μVp-p measured from 0.1 to 10Hz. This is approximately one-tenth the noise of “low noise” chopper-stabilized amplifiers.

## OFFSET TRIMMING

The INA115 is laser trimmed for very low offset voltage and drift. Most applications require no external offset adjustment. Figure 4 shows an optional circuit for trimming the output offset voltage. The voltage applied to Ref terminal is summed at the output. Low impedance must be maintained at this node to assure good common-mode rejection. This is achieved by buffering the trim voltage with an op amp as shown.

## INPUT BIAS CURRENT RETURN PATH

The input impedance of the INA115 is extremely high—approximately 10<sup>10</sup>Ω. However, a path must be provided for the input bias current of both inputs. This input bias current is typically less than ±1nA (it can be either polarity due to cancellation circuitry). High input impedance means that this input bias current changes very little with varying input voltage.

Input circuitry must provide a path for this input bias current if the INA115 is to operate properly. Figure 5 shows various provisions for an input bias current path. Without a bias current return path, the inputs will float to a potential which exceeds the common-mode range of the INA115 and the input amplifiers will saturate. If the differential source resistance is low, a bias current return path can be connected to one input (see thermocouple example in Figure 5). With higher source impedance, using two resistors provides a balanced input with possible advantages of lower input offset voltage due bias current and better common-mode rejection.

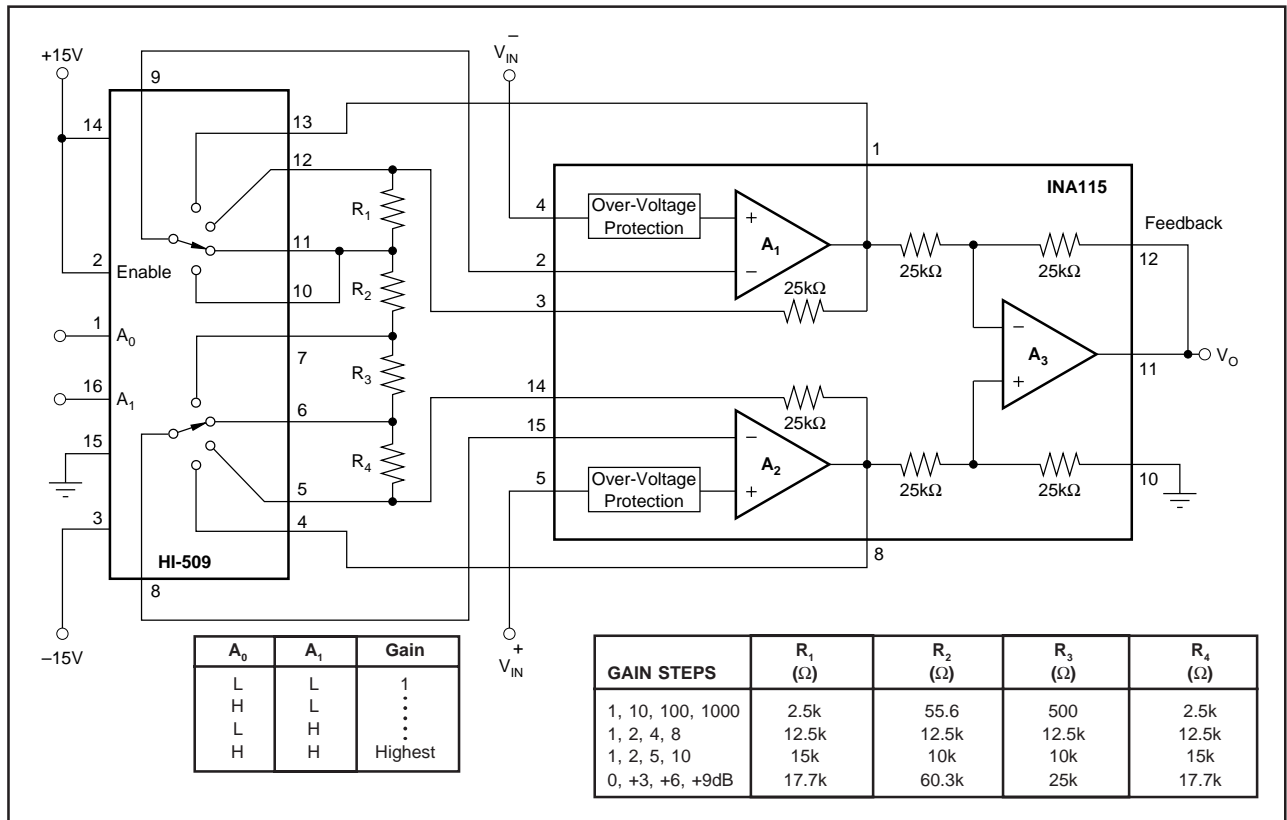

FIGURE 2. Switched-Gain Instrumentation Amplifier (minimum components).

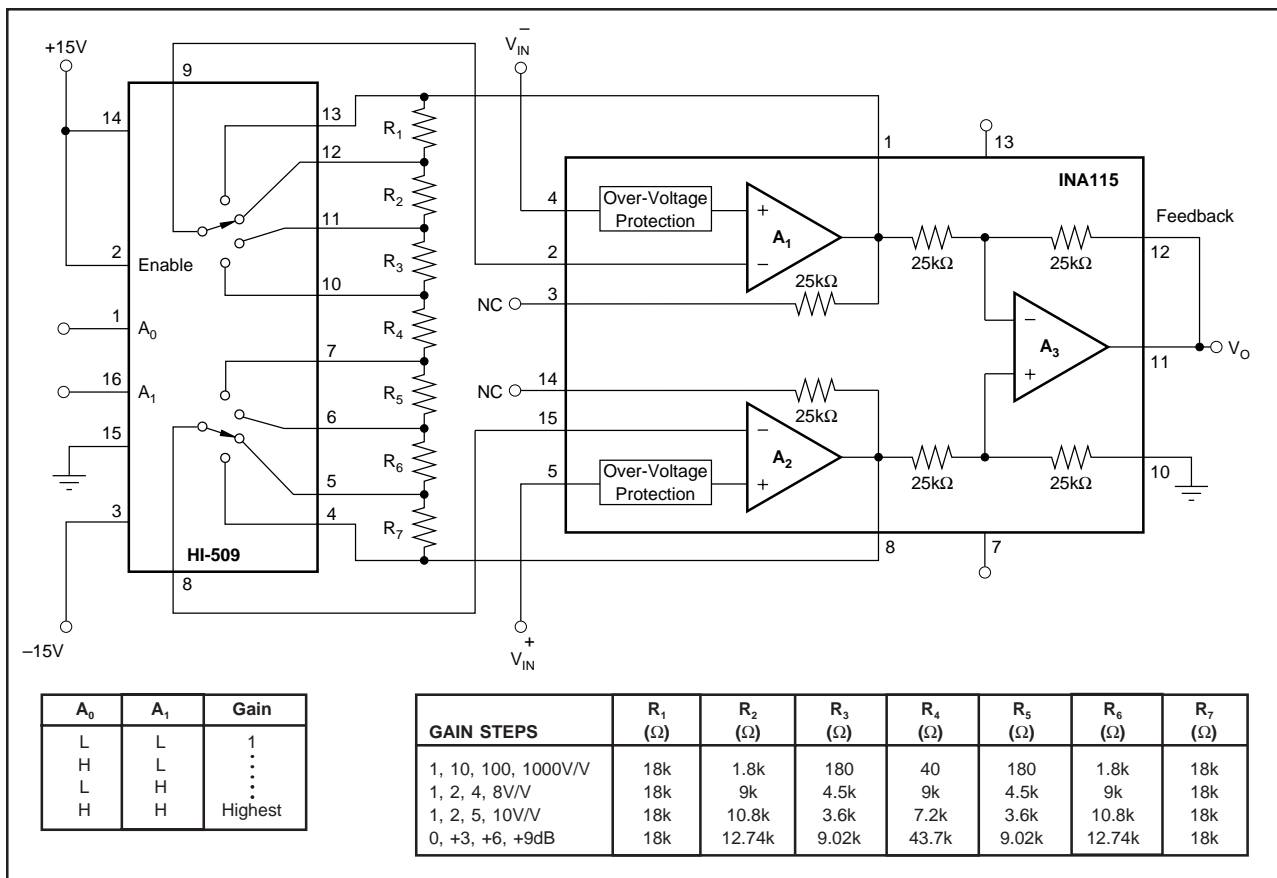

FIGURE 3. Switched-Gain Instrumentation Amplifier (improved gain drift).

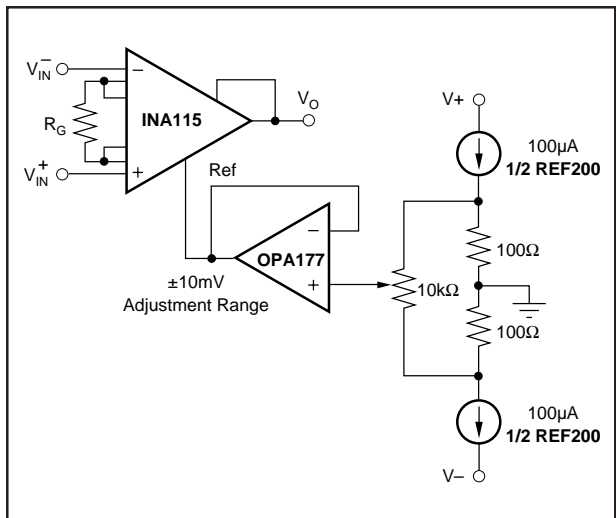

FIGURE 4. Optional Trimming of Output Offset Voltage.

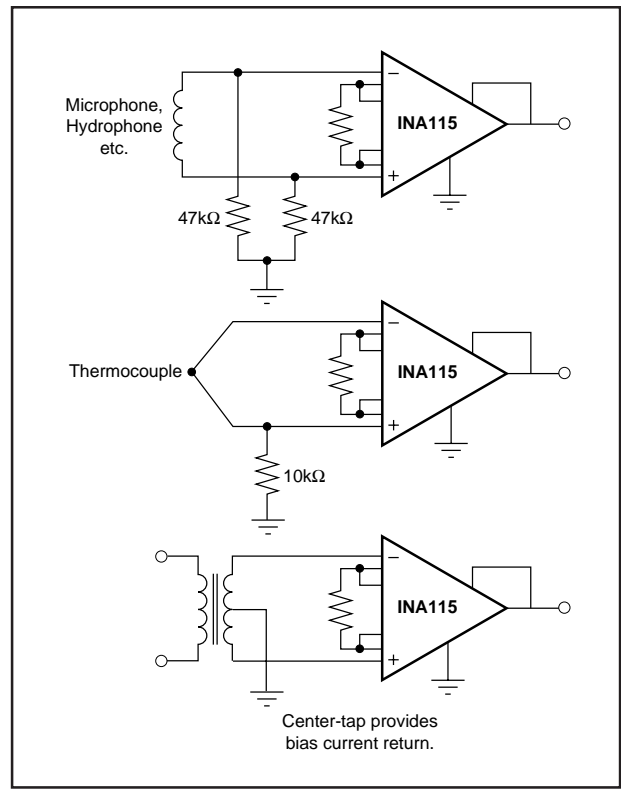

FIGURE 5. Providing an Input Common-Mode Current Path.

## INPUT COMMON-MODE RANGE

The linear common-mode range of the input op amps of the INA115 is approximately  $\pm 13.75\text{V}$  (or  $1.25\text{V}$  from the power supplies). As the output voltage increases, however, the linear input range will be limited by the output voltage swing of the input amplifiers,  $A_1$  and  $A_2$ . The common-mode range is related to the output voltage of the complete amplifier—see performance curve “Input Common-Mode Range vs Output Voltage.”

A combination of common-mode and differential input signals can cause the output of  $A_1$  or  $A_2$  to saturate. Figure 6 shows the output voltage swing of  $A_1$  and  $A_2$  expressed in terms of a common-mode and differential input voltages. Output swing capability of the input amplifiers,  $A_1$  and  $A_2$  is the same as the output amplifier,  $A_3$ . For applications where input common-mode range must be maximized, limit the output voltage swing by connecting the INA115 in a lower gain (see performance curve “Input Common-Mode Voltage Range vs Output Voltage”). If necessary, add gain after the INA115 to increase the voltage swing.

Input-overload often produces an output voltage that appears normal. For example, an input voltage of  $+20\text{V}$  on one input and  $+40\text{V}$  on the other input will obviously exceed the linear

common-mode range of both input amplifiers. Since both input amplifiers are saturated to the nearly the same output voltage limit, the difference voltage measured by the output amplifier will be near zero. The output of the INA115 will be near  $0\text{V}$  even though both inputs are overloaded.

## INPUT PROTECTION

The inputs of the INA115 are individually protected for voltages up to  $\pm 40\text{V}$ . For example, a condition of  $-40\text{V}$  on one input and  $+40\text{V}$  on the other input will not cause damage. Internal circuitry on each input provides low series impedance under normal signal conditions. To provide equivalent protection, series input resistors would contribute excessive noise. If the input is overloaded, the protection circuitry limits the input current to a safe value (approximately  $1.5\text{mA}$ ). The typical performance curve “Input Bias Current vs Common-Mode Input Voltage” shows this input current limit behavior. The inputs are protected even if the power supply voltage is zero.

## OTHER APPLICATIONS

See the INA114 data sheet for other applications circuits of general interest.

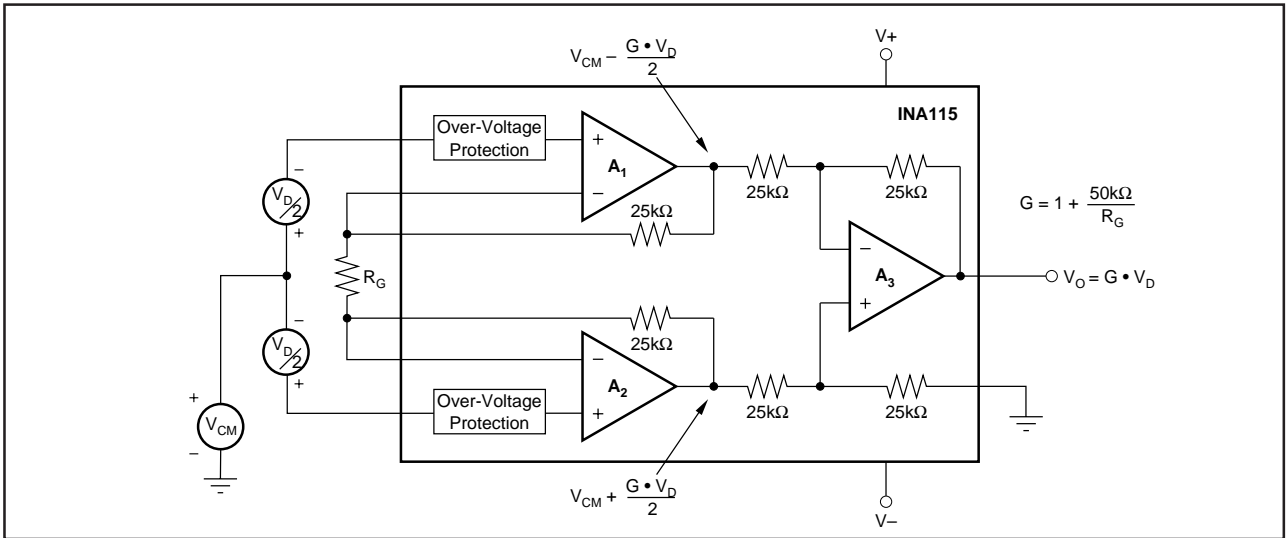

FIGURE 6. Voltage Swing of  $A_1$  and  $A_2$ .

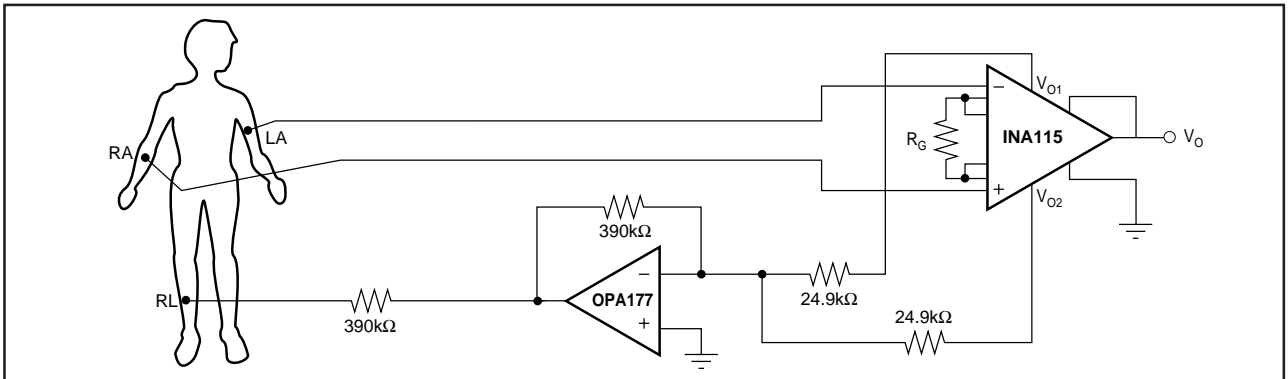

FIGURE 7. ECG Amplifier with Right Leg Drive.

**PACKAGING INFORMATION**

Orderable Device	Status (1)	Package Type	Package Drawing	Pins	Package Qty	Eco Plan (2)	Lead/Ball Finish (6)	MSL Peak Temp (3)	Op Temp (°C)	Device Marking (4/5)	Samples
INA115AU	ACTIVE	SOIC	DW	16	40	Green (RoHS & no Sb/Br)	CU NIPDAU-DCC	Level-3-260C-168 HR	-40 to 85	INA115AU	<a href="#">Samples</a>
INA115AU/1K	ACTIVE	SOIC	DW	16	1000	Green (RoHS & no Sb/Br)	CU NIPDAU-DCC	Level-3-260C-168 HR		INA115AU	<a href="#">Samples</a>
INA115BU	ACTIVE	SOIC	DW	16	40	Green (RoHS & no Sb/Br)	CU NIPDAU-DCC	Level-3-260C-168 HR		INA115BU	<a href="#">Samples</a>

(1) The marketing status values are defined as follows:

**ACTIVE:** Product device recommended for new designs.

**LIFEBUY:** TI has announced that the device will be discontinued, and a lifetime-buy period is in effect.

**NRND:** Not recommended for new designs. Device is in production to support existing customers, but TI does not recommend using this part in a new design.

**PREVIEW:** Device has been announced but is not in production. Samples may or may not be available.

**OBSOLETE:** TI has discontinued the production of the device.

(2) **RoHS:** TI defines "RoHS" to mean semiconductor products that are compliant with the current EU RoHS requirements for all 10 RoHS substances, including the requirement that RoHS substance do not exceed 0.1% by weight in homogeneous materials. Where designed to be soldered at high temperatures, "RoHS" products are suitable for use in specified lead-free processes. TI may reference these types of products as "Pb-Free".

**RoHS Exempt:** TI defines "RoHS Exempt" to mean products that contain lead but are compliant with EU RoHS pursuant to a specific EU RoHS exemption.

**Green:** TI defines "Green" to mean the content of Chlorine (Cl) and Bromine (Br) based flame retardants meet JS709B low halogen requirements of <=1000ppm threshold. Antimony trioxide based flame retardants must also meet the <=1000ppm threshold requirement.

(3) MSL, Peak Temp. - The Moisture Sensitivity Level rating according to the JEDEC industry standard classifications, and peak solder temperature.

(4) There may be additional marking, which relates to the logo, the lot trace code information, or the environmental category on the device.

(5) Multiple Device Markings will be inside parentheses. Only one Device Marking contained in parentheses and separated by a "~" will appear on a device. If a line is indented then it is a continuation of the previous line and the two combined represent the entire Device Marking for that device.

(6) Lead/Ball Finish - Orderable Devices may have multiple material finish options. Finish options are separated by a vertical ruled line. Lead/Ball Finish values may wrap to two lines if the finish value exceeds the maximum column width.

**Important Information and Disclaimer:** The information provided on this page represents TI's knowledge and belief as of the date that it is provided. TI bases its knowledge and belief on information provided by third parties, and makes no representation or warranty as to the accuracy of such information. Efforts are underway to better integrate information from third parties. TI has taken and continues to take reasonable steps to provide representative and accurate information but may not have conducted destructive testing or chemical analysis on incoming materials and chemicals. TI and TI suppliers consider certain information to be proprietary, and thus CAS numbers and other limited information may not be available for release.

In no event shall TI's liability arising out of such information exceed the total purchase price of the TI part(s) at issue in this document sold by TI to Customer on an annual basis.

## TAPE AND REEL INFORMATION



### QUADRANT ASSIGNMENTS FOR PIN 1 ORIENTATION IN TAPE



\*All dimensions are nominal

Device	Package Type	Package Drawing	Pins	SPQ	Reel Diameter (mm)	Reel Width W1 (mm)	A0 (mm)	B0 (mm)	K0 (mm)	P1 (mm)	W (mm)	Pin1 Quadrant
INA115AU/1K	SOIC	DW	16	1000	330.0	16.4	10.75	10.7	2.7	12.0	16.0	Q1

**TAPE AND REEL BOX DIMENSIONS**



\*All dimensions are nominal

Device	Package Type	Package Drawing	Pins	SPQ	Length (mm)	Width (mm)	Height (mm)
INA115AU/1K	SOIC	DW	16	1000	367.0	367.0	38.0

## IMPORTANT NOTICE

Texas Instruments Incorporated (TI) reserves the right to make corrections, enhancements, improvements and other changes to its semiconductor products and services per JESD46, latest issue, and to discontinue any product or service per JESD48, latest issue. Buyers should obtain the latest relevant information before placing orders and should verify that such information is current and complete.

TI's published terms of sale for semiconductor products (<http://www.ti.com/sc/docs/stdterms.htm>) apply to the sale of packaged integrated circuit products that TI has qualified and released to market. Additional terms may apply to the use or sale of other types of TI products and services.

Reproduction of significant portions of TI information in TI data sheets is permissible only if reproduction is without alteration and is accompanied by all associated warranties, conditions, limitations, and notices. TI is not responsible or liable for such reproduced documentation. Information of third parties may be subject to additional restrictions. Resale of TI products or services with statements different from or beyond the parameters stated by TI for that product or service voids all express and any implied warranties for the associated TI product or service and is an unfair and deceptive business practice. TI is not responsible or liable for any such statements.

Buyers and others who are developing systems that incorporate TI products (collectively, "Designers") understand and agree that Designers remain responsible for using their independent analysis, evaluation and judgment in designing their applications and that Designers have full and exclusive responsibility to assure the safety of Designers' applications and compliance of their applications (and of all TI products used in or for Designers' applications) with all applicable regulations, laws and other applicable requirements. Designer represents that, with respect to their applications, Designer has all the necessary expertise to create and implement safeguards that (1) anticipate dangerous consequences of failures, (2) monitor failures and their consequences, and (3) lessen the likelihood of failures that might cause harm and take appropriate actions. Designer agrees that prior to using or distributing any applications that include TI products, Designer will thoroughly test such applications and the functionality of such TI products as used in such applications.

TI's provision of technical, application or other design advice, quality characterization, reliability data or other services or information, including, but not limited to, reference designs and materials relating to evaluation modules, (collectively, "TI Resources") are intended to assist designers who are developing applications that incorporate TI products; by downloading, accessing or using TI Resources in any way, Designer (individually or, if Designer is acting on behalf of a company, Designer's company) agrees to use any particular TI Resource solely for this purpose and subject to the terms of this Notice.

TI's provision of TI Resources does not expand or otherwise alter TI's applicable published warranties or warranty disclaimers for TI products, and no additional obligations or liabilities arise from TI providing such TI Resources. TI reserves the right to make corrections, enhancements, improvements and other changes to its TI Resources. TI has not conducted any testing other than that specifically described in the published documentation for a particular TI Resource.

Designer is authorized to use, copy and modify any individual TI Resource only in connection with the development of applications that include the TI product(s) identified in such TI Resource. NO OTHER LICENSE, EXPRESS OR IMPLIED, BY ESTOPPEL OR OTHERWISE TO ANY OTHER TI INTELLECTUAL PROPERTY RIGHT, AND NO LICENSE TO ANY TECHNOLOGY OR INTELLECTUAL PROPERTY RIGHT OF TI OR ANY THIRD PARTY IS GRANTED HEREIN, including but not limited to any patent right, copyright, mask work right, or other intellectual property right relating to any combination, machine, or process in which TI products or services are used. Information regarding or referencing third-party products or services does not constitute a license to use such products or services, or a warranty or endorsement thereof. Use of TI Resources may require a license from a third party under the patents or other intellectual property of the third party, or a license from TI under the patents or other intellectual property of TI.

TI RESOURCES ARE PROVIDED "AS IS" AND WITH ALL FAULTS. TI DISCLAIMS ALL OTHER WARRANTIES OR REPRESENTATIONS, EXPRESS OR IMPLIED, REGARDING RESOURCES OR USE THEREOF, INCLUDING BUT NOT LIMITED TO ACCURACY OR COMPLETENESS, TITLE, ANY EPIDEMIC FAILURE WARRANTY AND ANY IMPLIED WARRANTIES OF MERCHANTABILITY, FITNESS FOR A PARTICULAR PURPOSE, AND NON-INFRINGEMENT OF ANY THIRD PARTY INTELLECTUAL PROPERTY RIGHTS. TI SHALL NOT BE LIABLE FOR AND SHALL NOT DEFEND OR INDEMNIFY DESIGNER AGAINST ANY CLAIM, INCLUDING BUT NOT LIMITED TO ANY INFRINGEMENT CLAIM THAT RELATES TO OR IS BASED ON ANY COMBINATION OF PRODUCTS EVEN IF DESCRIBED IN TI RESOURCES OR OTHERWISE. IN NO EVENT SHALL TI BE LIABLE FOR ANY ACTUAL, DIRECT, SPECIAL, COLLATERAL, INDIRECT, PUNITIVE, INCIDENTAL, CONSEQUENTIAL OR EXEMPLARY DAMAGES IN CONNECTION WITH OR ARISING OUT OF TI RESOURCES OR USE THEREOF, AND REGARDLESS OF WHETHER TI HAS BEEN ADVISED OF THE POSSIBILITY OF SUCH DAMAGES.

Unless TI has explicitly designated an individual product as meeting the requirements of a particular industry standard (e.g., ISO/TS 16949 and ISO 26262), TI is not responsible for any failure to meet such industry standard requirements.

Where TI specifically promotes products as facilitating functional safety or as compliant with industry functional safety standards, such products are intended to help enable customers to design and create their own applications that meet applicable functional safety standards and requirements. Using products in an application does not by itself establish any safety features in the application. Designers must ensure compliance with safety-related requirements and standards applicable to their applications. Designer may not use any TI products in life-critical medical equipment unless authorized officers of the parties have executed a special contract specifically governing such use. Life-critical medical equipment is medical equipment where failure of such equipment would cause serious bodily injury or death (e.g., life support, pacemakers, defibrillators, heart pumps, neurostimulators, and implantables). Such equipment includes, without limitation, all medical devices identified by the U.S. Food and Drug Administration as Class III devices and equivalent classifications outside the U.S.

TI may expressly designate certain products as completing a particular qualification (e.g., Q100, Military Grade, or Enhanced Product). Designers agree that it has the necessary expertise to select the product with the appropriate qualification designation for their applications and that proper product selection is at Designers' own risk. Designers are solely responsible for compliance with all legal and regulatory requirements in connection with such selection.

Designer will fully indemnify TI and its representatives against any damages, costs, losses, and/or liabilities arising out of Designer's non-compliance with the terms and provisions of this Notice.

## Looking for pricing, stock, or lifecycle information?

Click below to explore more details on WIN SOURCE:

 [View INA115BU](#) on WIN SOURCE

 [Texas Instruments](#) Information

## Optimize Your Supply Chain with WIN SOURCE Solutions

-  Global Sourcing Solution
-  Obsolete Management
-  Cost Control Management
-  Shortage Management
-  Alternative Solution
-  Excess Inventory Management