

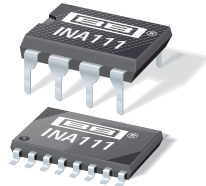

THE DATASHEET OF INA111AP





INA111

High Speed FET-Input INSTRUMENTATION AMPLIFIER

FEATURES

- FET INPUT: $I_B = 20\text{pA max}$
- HIGH SPEED: $T_s = 4\mu\text{s (G = 100, 0.01\%)}$
- LOW OFFSET VOLTAGE: $500\mu\text{V max}$
- LOW OFFSET VOLTAGE DRIFT: $5\mu\text{V}/^\circ\text{C max}$
- HIGH COMMON-MODE REJECTION: 106dB min
- 8-PIN PLASTIC DIP, SOL-16 SOIC

APPLICATIONS

- MEDICAL INSTRUMENTATION
- DATA ACQUISITION

DESCRIPTION

The INA111 is a high speed, FET-input instrumentation amplifier offering excellent performance.

The INA111 uses a current-feedback topology providing extended bandwidth (2MHz at $G = 10$) and fast settling time ($4\mu\text{s}$ to 0.01% at $G = 100$). A single external resistor sets any gain from 1 to over 1000.

Offset voltage and drift are laser trimmed for excellent DC accuracy. The INA111's FET inputs reduce input bias current to under 20pA, simplifying input filtering and limiting circuitry.

The INA111 is available in 8-pin plastic DIP, and SOL-16 surface-mount packages, specified for the -40°C to $+85^\circ\text{C}$ temperature range.

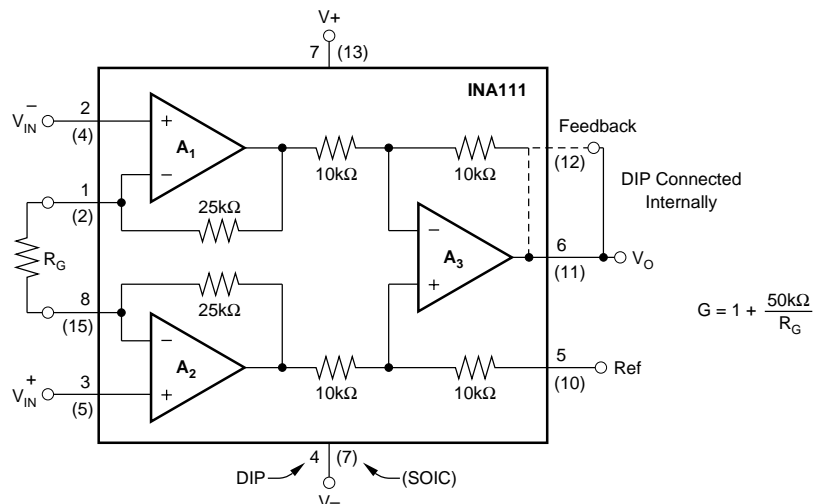

SPECIFICATIONS

ELECTRICAL

At $T_A = +25^\circ\text{C}$, $V_S = \pm 15\text{V}$, $R_L = 2\text{k}\Omega$, unless otherwise noted.

PARAMETER	CONDITIONS	INA111BP, BU			INA111AP, AU			UNITS
		MIN	TYP	MAX	MIN	TYP	MAX	
INPUT								
Offset Voltage, RTI								
Initial	$T_A = +25^\circ\text{C}$		$\pm 100 \pm 500/\text{G}$	$\pm 500 \pm 2000/\text{G}$		$\pm 200 \pm 500/\text{G}$	$\pm 1000 \pm 5000/\text{G}$	μV
vs Temperature	$T_A = T_{\text{MIN}}$ to T_{MAX}		$\pm 2 \pm 10/\text{G}$	$\pm 5 \pm 100/\text{G}$		$\pm 2 \pm 20/\text{G}$	$\pm 10 \pm 100/\text{G}$	$\mu\text{V}/^\circ\text{C}$
vs Power Supply	$V_S = \pm 6\text{V}$ to $\pm 18\text{V}$		$2 + 10/\text{G}$	$30 + 100/\text{G}$		*	*	$\mu\text{V}/\text{V}$
Impedance, Differential			$10^{12} \parallel 6$			*	*	$\Omega \parallel \text{pF}$
Common-Mode			$10^{12} \parallel 3$			*	*	$\Omega \parallel \text{pF}$
Input Common-Mode Range	$V_{\text{DIFF}} = 0\text{V}$	± 10	± 12		*	*		V
Common-Mode Rejection	$V_{\text{CM}} = \pm 10\text{V}$, $\Delta R_S = 1\text{k}\Omega$							
	G = 1	80	90		75	*		dB
	G = 10	96	110		90	*		dB
	G = 100	106	115		100	*		dB
	G = 1000	106	115		100	*		dB
BIAS CURRENT			± 2	± 20		*	*	pA
OFFSET CURRENT			± 0.1	± 10		*	*	pA
NOISE VOLTAGE, RTI	G = 1000, $R_S = 0\Omega$							
f = 100Hz			13			*		$\text{nV}/\sqrt{\text{Hz}}$
f = 1kHz			10			*		$\text{nV}/\sqrt{\text{Hz}}$
f = 10kHz			10			*		$\text{nV}/\sqrt{\text{Hz}}$
$f_B = 0.1\text{Hz}$ to 10Hz			1			*		$\mu\text{Vp-p}$
Noise Current								
f = 10kHz			0.8			*		$\text{fA}/\sqrt{\text{Hz}}$
GAIN								
Gain Equation			$1 + (50\text{k}\Omega/R_G)$			*		V/V
Range of Gain		1		10000	*		*	V/V
Gain Error	G = 1, $R_L = 10\text{k}\Omega$		± 0.01	± 0.02		*	0.05	%
	G = 10, $R_L = 10\text{k}\Omega$		± 0.1	± 0.5		*	*	%
	G = 100, $R_L = 10\text{k}\Omega$		± 0.15	± 0.5		*	± 0.7	%
	G = 1000, $R_L = 10\text{k}\Omega$		± 0.25	± 1		*	± 2	%
Gain vs Temperature	G = 1		± 1	± 10		*	*	$\text{ppm}/^\circ\text{C}$
50k Ω Resistance ⁽¹⁾			± 25	± 100		*	*	$\text{ppm}/^\circ\text{C}$
Nonlinearity	G = 1		± 0.0005	± 0.005		*	*	% of FSR
	G = 10		± 0.001	± 0.005		*	± 0.01	% of FSR
	G = 100		± 0.001	± 0.005		*	± 0.01	% of FSR
	G = 1000		± 0.005	± 0.02		*	± 0.04	% of FSR
OUTPUT								
Voltage	$I_O = 5\text{mA}$, T_{MIN} to T_{MAX}	± 11	± 12.7		*	*		V
Load Capacitance Stability			1000			*		pF
Short Circuit Current			$+30/-25$			*		mA
FREQUENCY RESPONSE								
Bandwidth, -3dB	G = 1		2			*		MHz
	G = 10		2			*		MHz
	G = 100		450			*		kHz
	G = 1000		50			*		kHz
Slew Rate	$V_O = \pm 10\text{V}$, G = 2 to 100		17			*		V/ μs
Settling Time, 0.01%	G = 1		2			*		μs
	G = 10		2			*		μs
	G = 100		4			*		μs
	G = 1000		30			*		μs
Overload Recovery	50% Overdrive		1			*		μs
POWER SUPPLY								
Voltage Range		± 6	± 15	± 18	*	*	*	V
Current	$V_{\text{IN}} = 0\text{V}$		± 3.3	± 4.5		*	*	mA
TEMPERATURE RANGE								
Specification		-40		85	*		*	$^\circ\text{C}$
Operating		-40		125	*		*	$^\circ\text{C}$
θ_{JA}			100			*		$^\circ\text{C}/\text{W}$

* Specification same as INA111BP.

NOTE: (1) Temperature coefficient of the "50k Ω " term in the gain equation.

The information provided herein is believed to be reliable; however, BURR-BROWN assumes no responsibility for inaccuracies or omissions. BURR-BROWN assumes no responsibility for the use of this information, and all use of such information shall be entirely at the user's own risk. Prices and specifications are subject to change without notice. No patent rights or licenses to any of the circuits described herein are implied or granted to any third party. BURR-BROWN does not authorize or warrant any BURR-BROWN product for use in life support devices and/or systems.

PIN CONFIGURATIONS

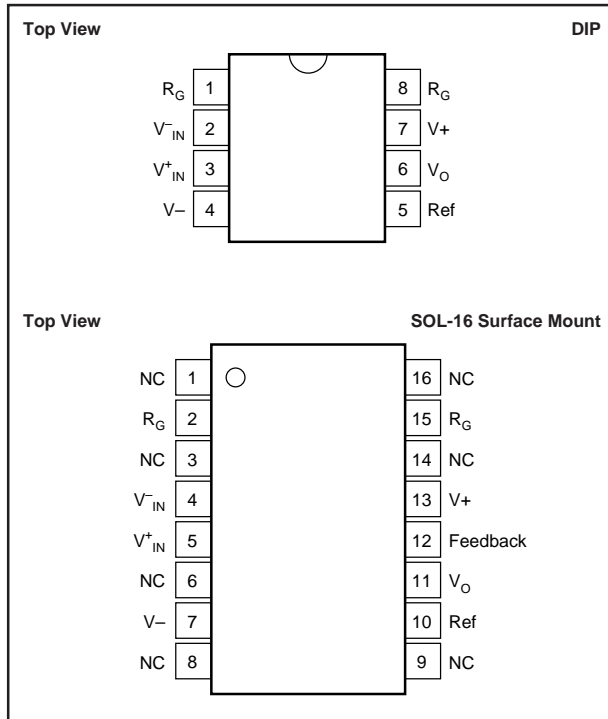

ABSOLUTE MAXIMUM RATINGS⁽¹⁾

Supply Voltage	±18V
Input Voltage Range	(V ₋) -0.7V to (V ₊) +15V
Output Short-Circuit (to ground)	Continuous
Operating Temperature	-40°C to +125°C
Storage Temperature	-40°C to +125°C
Junction Temperature	+150°C
Lead Temperature (soldering, 10s)	+300°C

NOTE: Stresses above these ratings may cause permanent damage.

ELECTROSTATIC DISCHARGE SENSITIVITY

This integrated circuit can be damaged by ESD. Burr-Brown recommends that all integrated circuits be handled with appropriate precautions. Failure to observe proper handling and installation procedures can cause damage.

ESD damage can range from subtle performance degradation to complete device failure. Precision integrated circuits may be more susceptible to damage because very small parametric changes could cause the device not to meet its published specifications.

ORDERING INFORMATION

PRODUCT	PACKAGE	TEMPERATURE RANGE
INA111AP	8-Pin Plastic DIP	-40°C to +85°C
INA111BP	8-Pin Plastic DIP	-40°C to +85°C
INA111AU	SOL-16 Surface-Mount	-40°C to +85°C
INA111BU	SOL-16 Surface-Mount	-40°C to +85°C

PACKAGE INFORMATION

PRODUCT	PACKAGE	PACKAGE DRAWING NUMBER ⁽¹⁾
INA111AP	8-Pin Plastic DIP	006
INA111BP	8-Pin Plastic DIP	006
INA111AU	16-Pin Surface Mount	211
INA111BU	16-Pin Surface Mount	211

NOTE: (1) For detailed drawing and dimension table, please see end of data sheet, or Appendix C of Burr-Brown IC Data Book.

TYPICAL PERFORMANCE CURVES

At $T_A = +25^\circ\text{C}$, $V_S = \pm 15\text{V}$, unless otherwise noted.

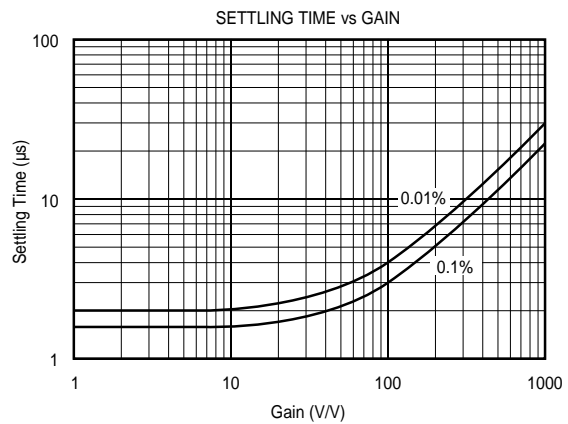
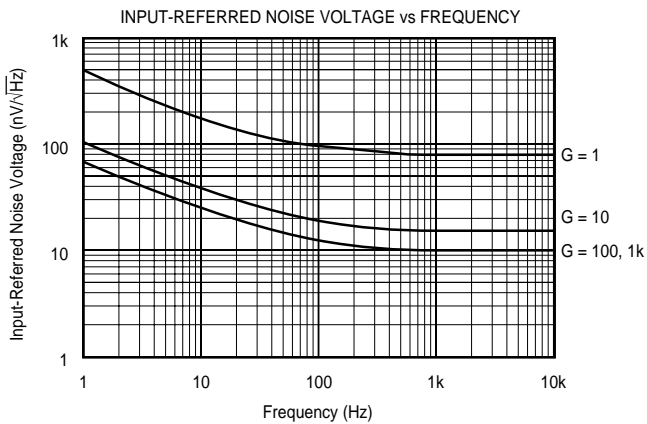
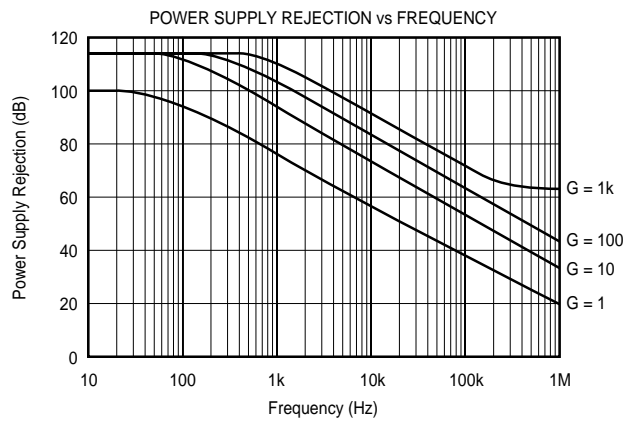
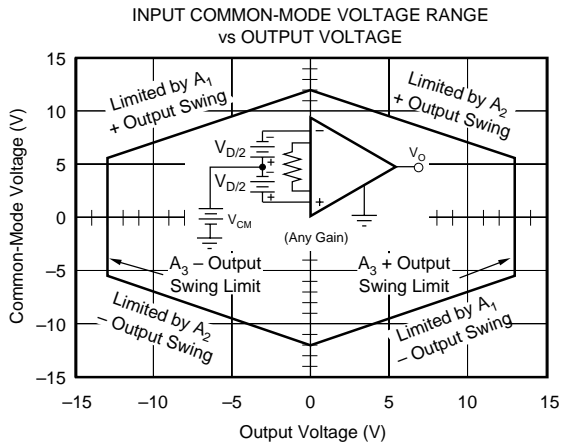
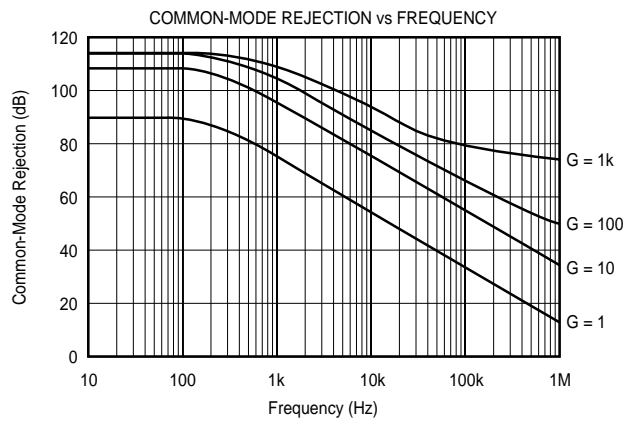
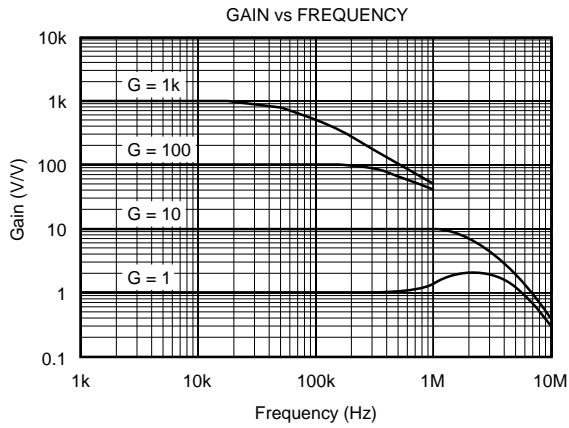

TYPICAL PERFORMANCE CURVES (CONT)

At $T_A = +25^\circ\text{C}$, $V_S = \pm 15\text{V}$, unless otherwise noted.

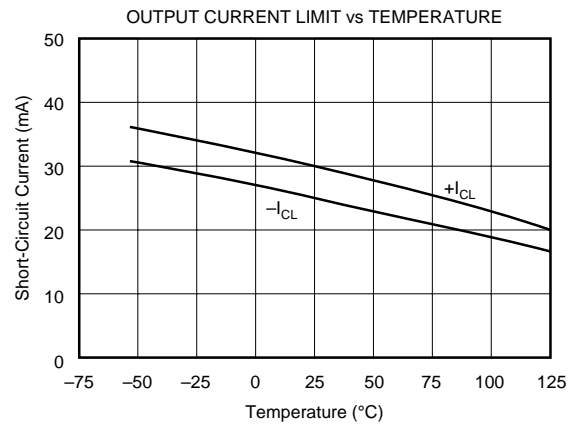
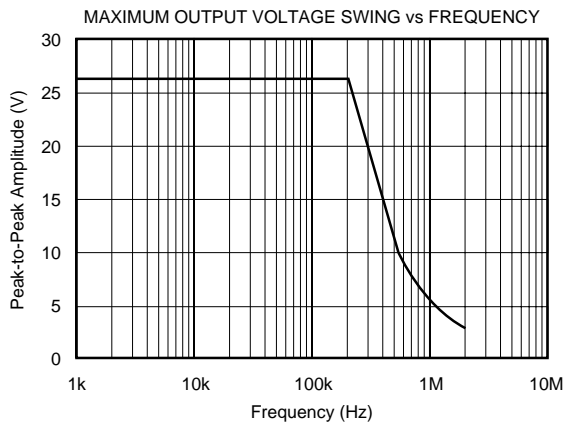
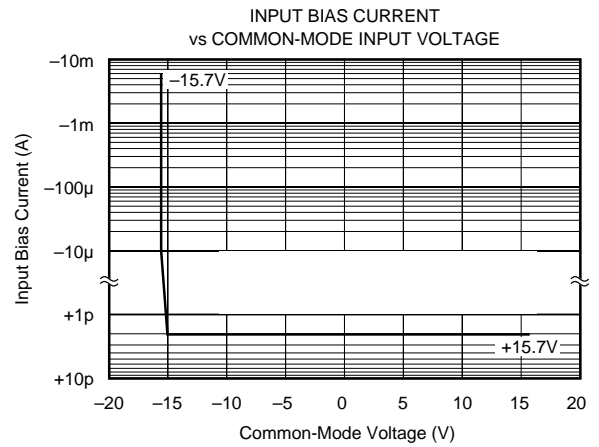
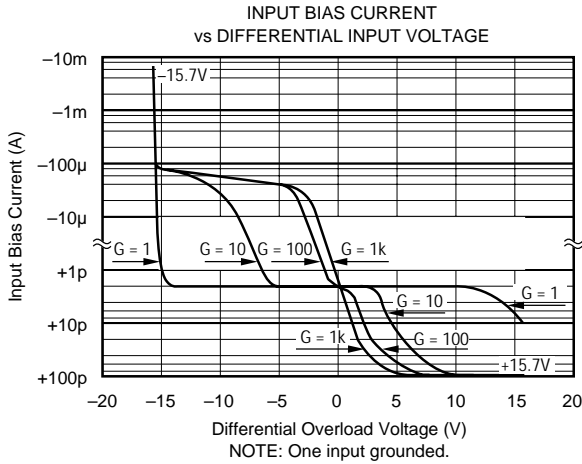
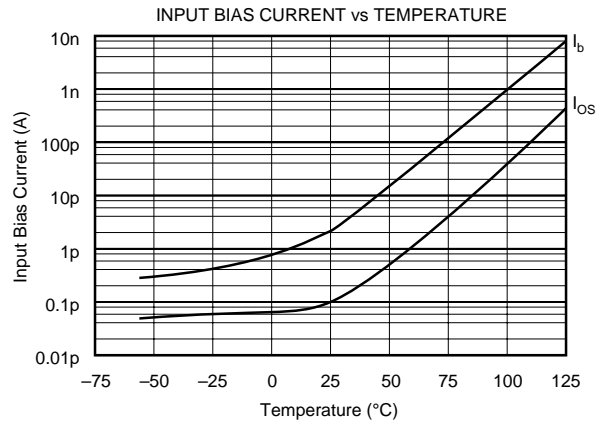
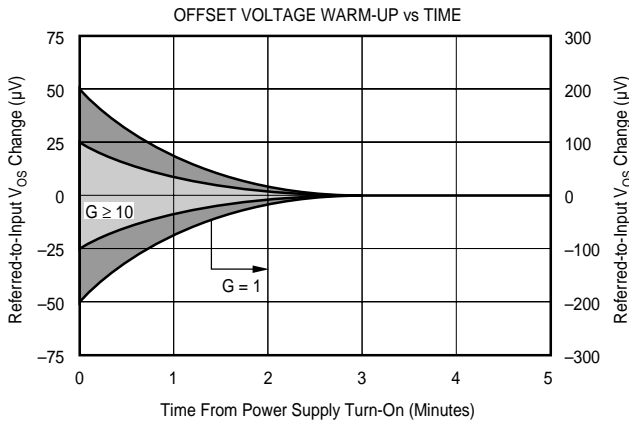

TYPICAL PERFORMANCE CURVES (CONT)

At $T_A = +25^\circ\text{C}$, $V_S = \pm 15\text{V}$, unless otherwise noted.

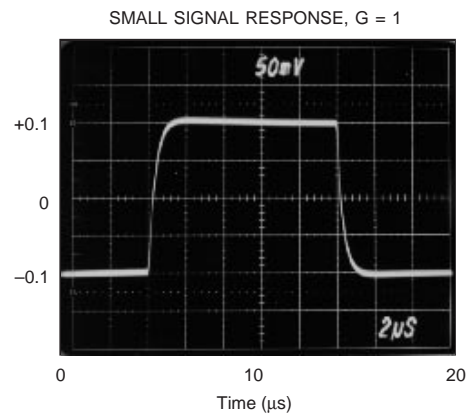
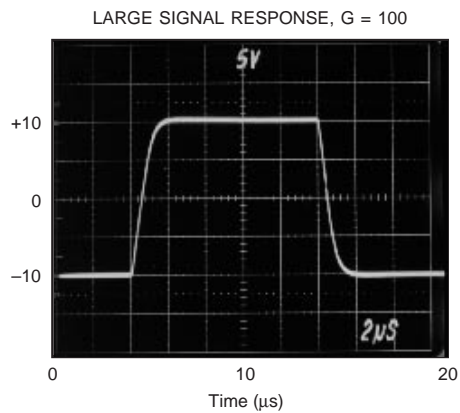
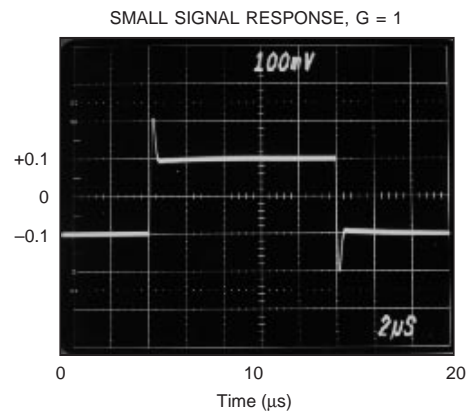
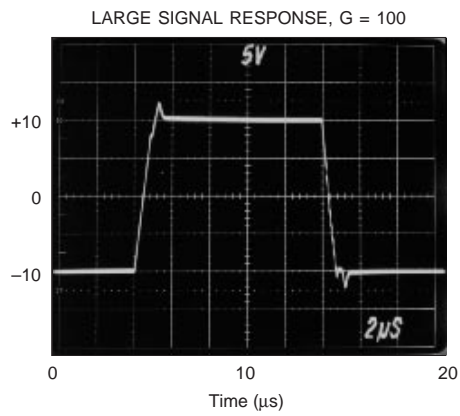
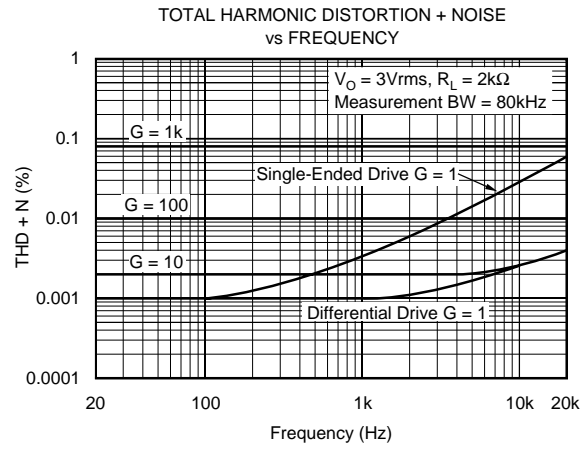
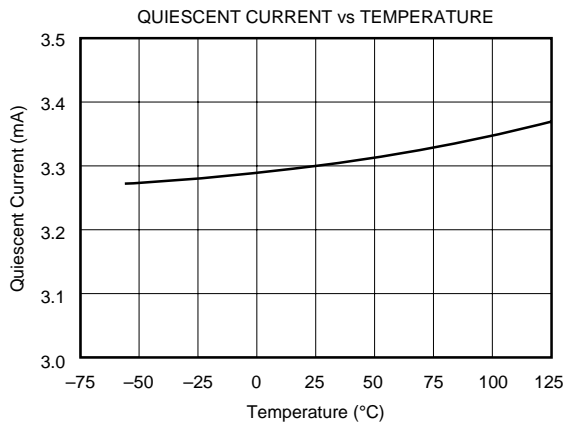

APPLICATION INFORMATION

Figure 1 shows the basic connections required for operation of the INA111. Applications with noisy or high impedance power supplies may require decoupling capacitors close to the device pins as shown.

The output is referred to the output reference (Ref) terminal which is normally grounded. This must be a low-impedance connection to assure good common-mode rejection. A resistance of 2Ω in series with the Ref pin will cause a typical device with 90dB CMR to degrade to approximately 80dB CMR ($G = 1$).

SETTING THE GAIN

Gain of the INA111 is set by connecting a single external resistor, R_G :

$$G = 1 + \frac{50k\Omega}{R_G} \quad (1)$$

Commonly used gains and resistor values are shown in Figure 1.

The 50kΩ term in equation 1 comes from the sum of the two internal feedback resistors. These are on-chip metal film resistors which are laser trimmed to accurate absolute values. The accuracy and temperature coefficient of these resistors are included in the gain accuracy and drift specifications of the INA111.

The stability and temperature drift of the external gain setting resistor, R_G , also affects gain. R_G 's contribution to gain accuracy and drift can be directly inferred from the gain equation (1). Low resistor values required for high gain can make wiring resistance important. Sockets add to the wiring resistance, which will contribute additional gain error (possibly an unstable gain error) in gains of approximately 100 or greater.

DYNAMIC PERFORMANCE

The typical performance curve "Gain vs Frequency" shows that the INA111 achieves wide bandwidth over a wide range of gain. This is due to the current-feedback topology of the INA111. Settling time also remains excellent over wide gains.

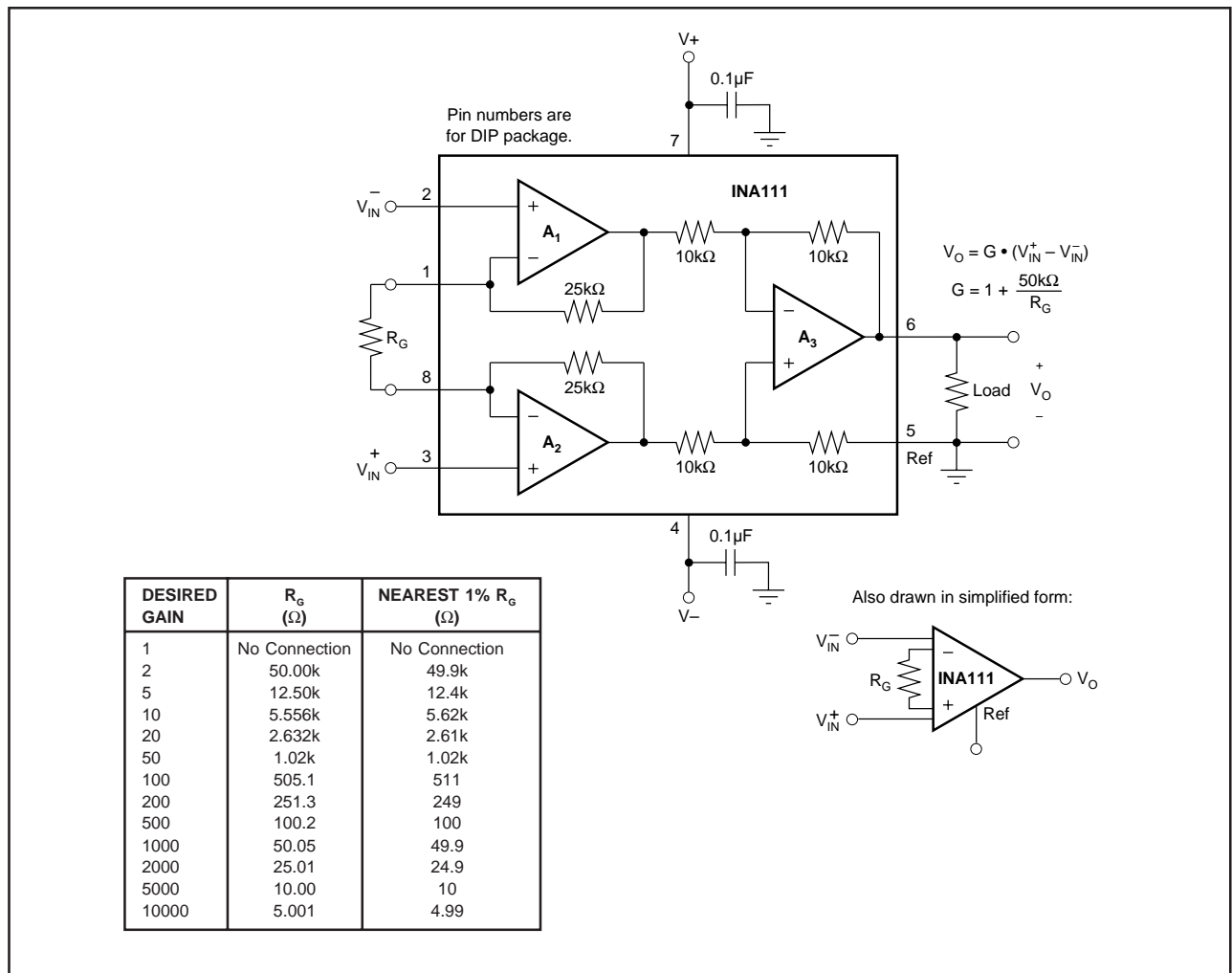

FIGURE 1. Basic Connections

The INA111 exhibits approximately 6dB rise in gain at 2MHz in unity gain. This is a result of its current-feedback topology and is not an indication of instability. Unlike an op amp with poor phase margin, the rise in response is a predictable +6dB/octave due to a response zero. A simple pole at 700kHz or lower will produce a flat passband response (see Input Filtering).

The INA111 provides excellent rejection of high frequency common-mode signals. The typical performance curve, “Common-Mode Rejection vs Frequency” shows this behavior. If the inputs are not properly balanced, however, common-mode signals can be converted to differential signals. Run the V_{IN}^+ and V_{IN}^- connections directly adjacent each other, from the source signal all the way to the input pins. If possible use a ground plane under both input traces. Avoid running other potentially noisy lines near the inputs.

NOISE AND ACCURACY PERFORMANCE

The INA111’s FET input circuitry provides low input bias current and high speed. It achieves lower noise and higher accuracy with high impedance sources. With source impedances of 2k Ω to 50k Ω the INA114 may provide lower offset voltage and drift. For very low source impedance ($\leq 1k\Omega$), the INA103 may provide improved accuracy and lower noise.

OFFSET TRIMMING

The INA111 is laser trimmed for low offset voltage and drift. Most applications require no external offset adjustment. Figure 2 shows an optional circuit for trimming the output offset voltage. The voltage applied to Ref terminal is summed at the output. Low impedance must be maintained at this node to assure good common-mode rejection. The op amp shown maintains low output impedance at high frequency. Trim circuits with higher source impedance should be buffered with an op amp follower circuit to assure low impedance on the Ref pin.

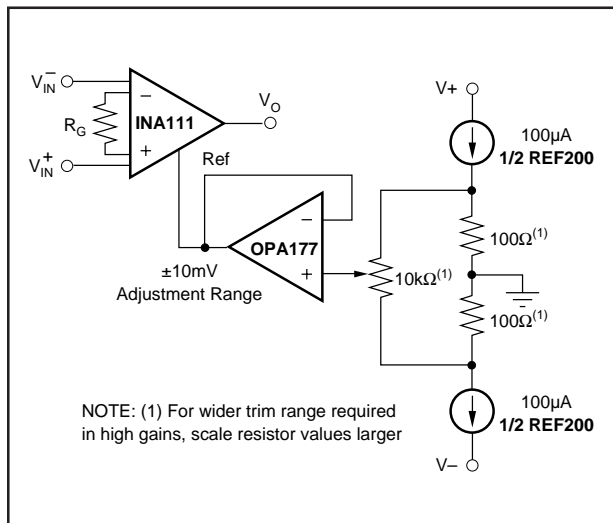

FIGURE 2. Optional Trimming of Output Offset Voltage.

INPUT BIAS CURRENT RETURN PATH

The input impedance of the INA111 is extremely high—approximately $10^{12}\Omega$. However, a path must be provided for the input bias current of both inputs. This input bias current is typically less than 10pA. High input impedance means that this input bias current changes very little with varying input voltage.

Input circuitry must provide a path for this input bias current if the INA111 is to operate properly. Figure 3 shows various provisions for an input bias current path. Without a bias current return path, the inputs will float to a potential which exceeds the common-mode range of the INA111 and the input amplifiers will saturate.

If the differential source resistance is low, the bias current return path can be connected to one input (see the thermocouple example in Figure 3). With higher source impedance, using two resistors provides a balanced input with possible advantages of lower input offset voltage due to bias current and better high-frequency common-mode rejection.

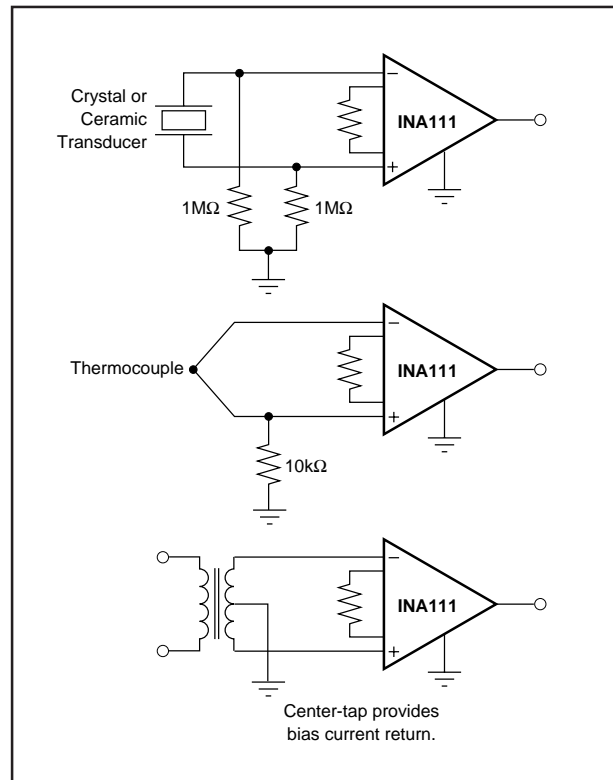

FIGURE 3. Providing an Input Common-Mode Current Path.

INPUT COMMON-MODE RANGE

The linear common-mode range of the input op amps of the INA111 is approximately $\pm 12V$ (or 3V from the power supplies). As the output voltage increases, however, the linear input range will be limited by the output voltage swing of the input amplifiers, A_1 and A_2 . The common-mode range is related to the output voltage of the complete amplifier—see performance curve “Input Common-Mode Range vs Output Voltage”.

A combination of common-mode and differential input voltage can cause the output of A_1 or A_2 to saturate. Figure 4 shows the output voltage swing of A_1 and A_2 expressed in terms of a common-mode and differential input voltages. For applications where input common-mode range must be maximized, limit the output voltage swing by connecting the INA111 in a lower gain (see performance curve "Input Common-Mode Voltage Range vs Output Voltage"). If necessary, add gain after the INA111 to increase the voltage swing.

Input-overload often produces an output voltage that appears normal. For example, consider an input voltage of +14V on one input and +15V on the other input will obviously exceed the linear common-mode range of both input amplifiers. Since both input amplifiers are saturated to the nearly the same output voltage limit, the difference voltage measured by the output amplifier will be near zero. The output of the INA111 will be near 0V even though both inputs are overloaded.

INPUT PROTECTION

Inputs of the INA111 are protected for input voltages from 0.7V below the negative supply to 15V above the positive power supply voltages. If the input current is limited to less than 1mA, clamp diodes are not required; internal junctions will clamp the input voltage to safe levels. If the input source can supply more than 1mA, use external clamp diodes as shown in Figure 5. The source current can be limited with series resistors R_1 and R_2 as shown. Resistor values greater than 10k Ω will contribute noise to the circuit.

A diode formed with a 2N4117A transistor as shown in Figure 5 assures low leakage. Common signal diodes such as

the 1N4148 may have leakage currents far greater than the input bias current of the INA111 and are usually sensitive to light.

INPUT FILTERING

The INA111's FET input allows use of an R/C input filter without creating large offsets due to input bias current. Figure 6 shows proper implementation of this input filter to preserve the INA111's excellent high frequency common-mode rejection. Mismatch of the common-mode input capacitance (C_1 and C_2), either from stray capacitance or

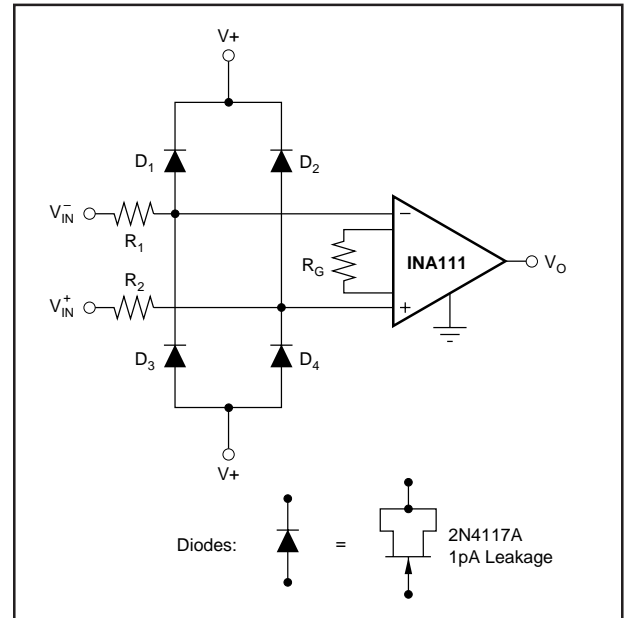

FIGURE 5. Input Protection Voltage Clamp.

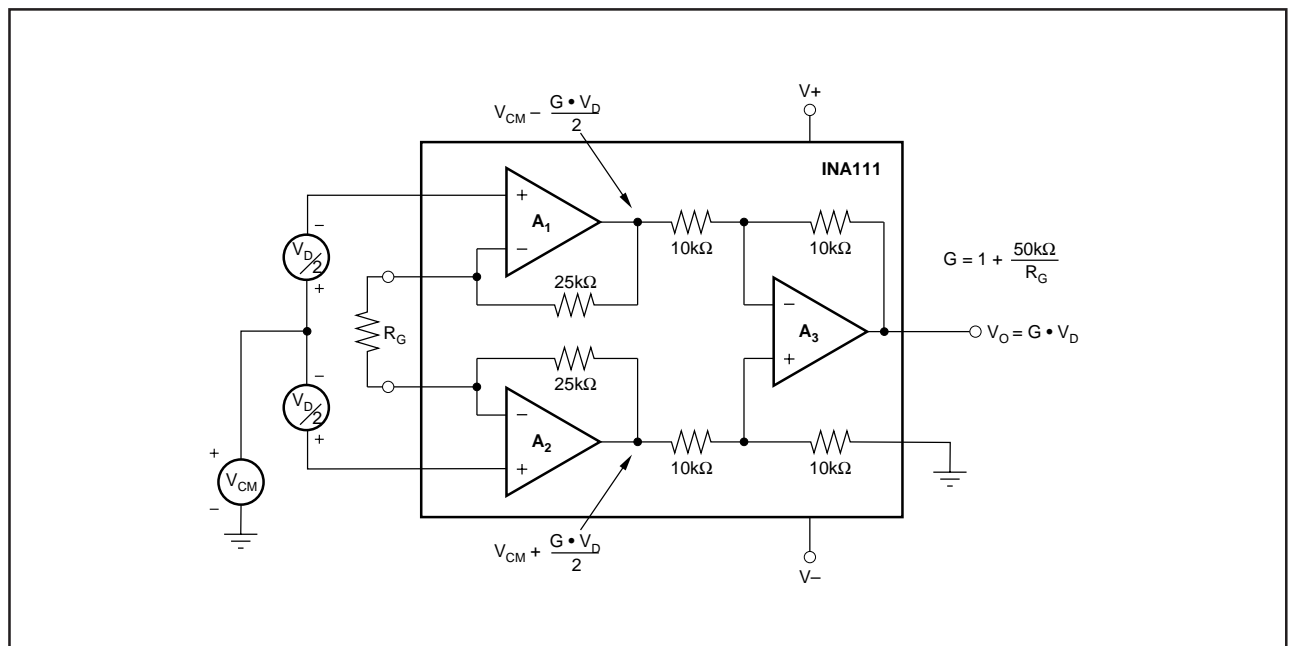

FIGURE 4. Voltage Swing of A_1 and A_2 .

mismatched values, causes a high frequency common-mode signal to be converted to a differential signal. This degrades common-mode rejection. The differential input capacitor, C_3 , reduces the bandwidth and mitigates the effects of mismatch in C_1 and C_2 . Make C_3 much larger than C_1 and C_2 . If properly matched, C_1 and C_2 also improve CMR.

OUTPUT VOLTAGE SENSE (SOL-16 Package Only)

The surface-mount version of the INA111 has a separate output sense feedback connection (pin 12). Pin 12 must be connected, usually to the output terminal, pin 11, for proper operation. (This connection is made internally on the DIP version of the INA111.)

The output feedback connection can be used to sense the output voltage directly at the load for best accuracy. Figure 8 shows how to drive a load through series interconnection resistance. Remotely located feedback paths may cause instability. This can be generally be eliminated with a high frequency feedback path through C_1 .

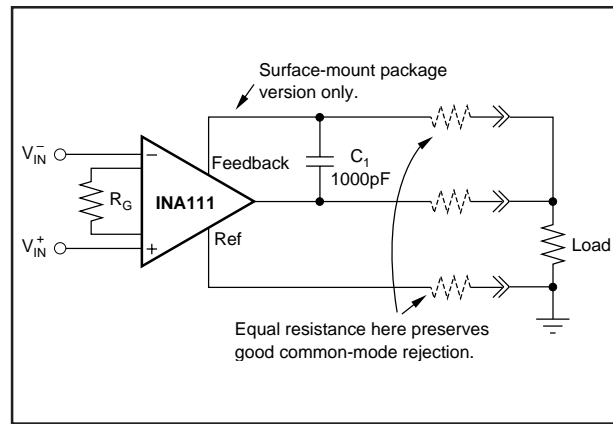
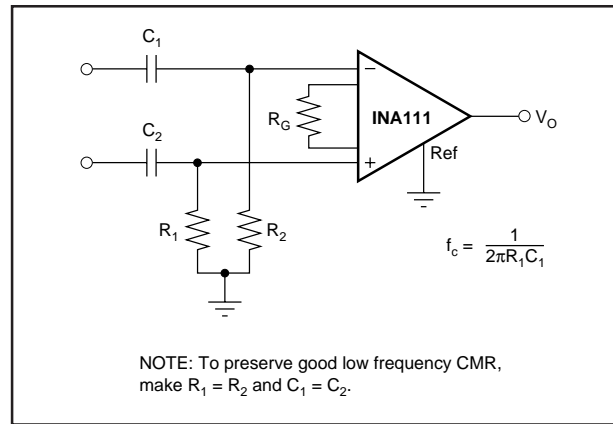
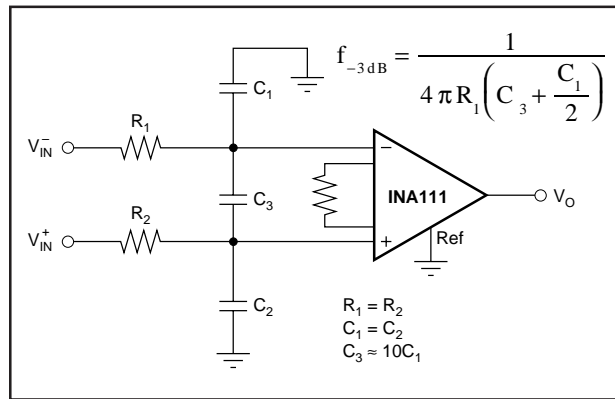

FIGURE 8. Remote Load and Ground Sensing.



NOTE: To preserve good low frequency CMR, make $R_1 = R_2$ and $C_1 = C_2$.

FIGURE 9. High-Pass Input Filter.



$R_1 = R_2$
 $C_1 = C_2$
 $C_3 \approx 10C_1$

FIGURE 6. Input Low-Pass Filter.

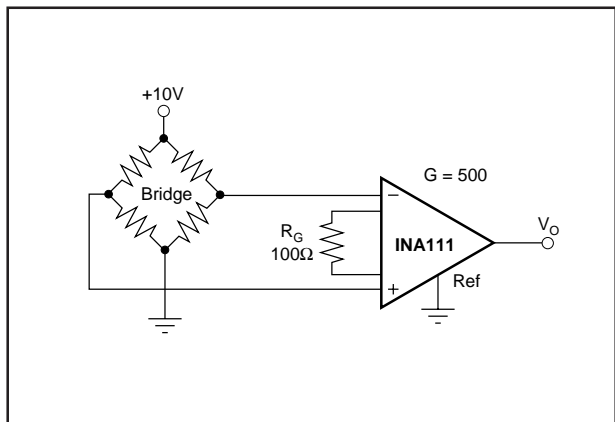

FIGURE 7. Bridge Transducer Amplifier.

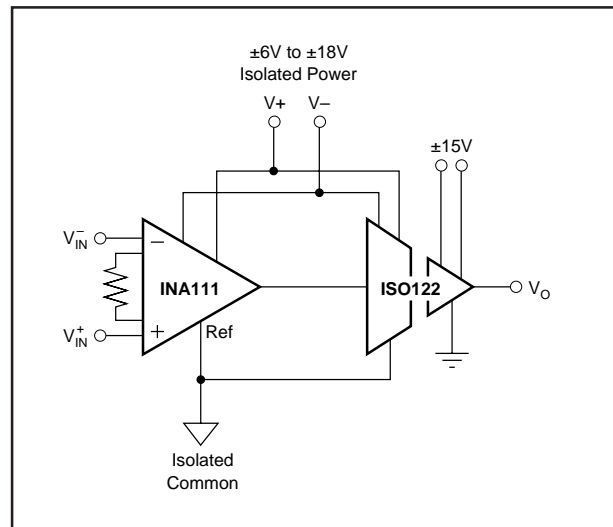

FIGURE 10. Galvanically Isolated Instrumentation Amplifier.

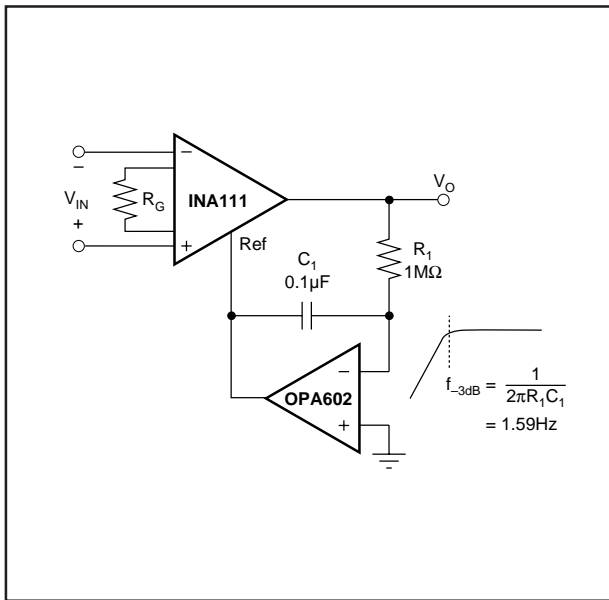

FIGURE 11. AC-Coupled Instrumentation Amplifier.

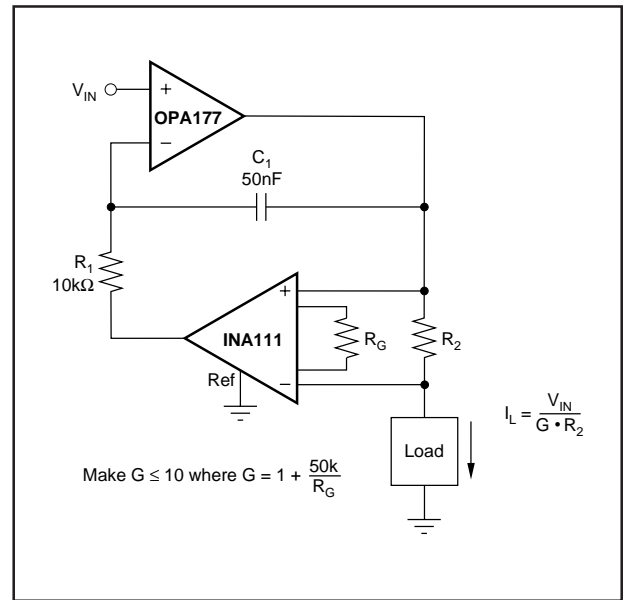

FIGURE 12. Voltage Controlled Current Source.

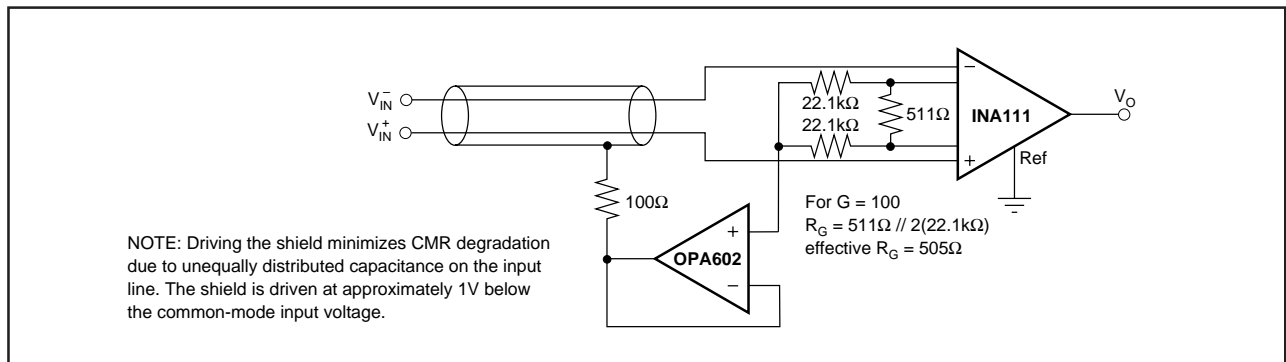

FIGURE 13. Shield Driver Circuit.

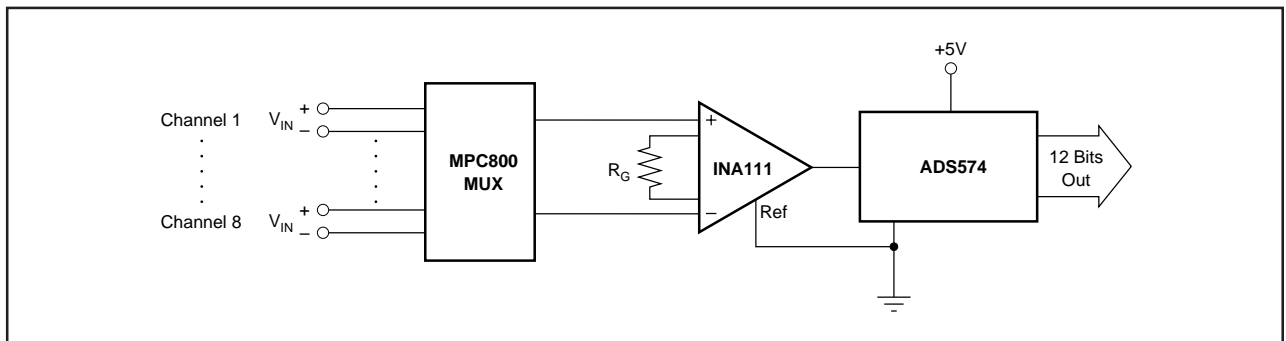

FIGURE 14. Multiplexed-Input Data Acquisition System.

PACKAGING INFORMATION

Orderable Device	Status (1)	Package Type	Package Drawing	Pins	Package Qty	Eco Plan (2)	Lead finish/ Ball material (6)	MSL Peak Temp (3)	Op Temp (°C)	Device Marking (4/5)	Samples
INA111AP	ACTIVE	PDIP	P	8	50	RoHS & Green	NIPDAU	N / A for Pkg Type		INA111AP	Samples
INA111AU	ACTIVE	SOIC	DW	16	40	RoHS & Green	NIPDAU	Level-3-260C-168 HR	-40 to 85	INA111AU	Samples
INA111AU/1K	ACTIVE	SOIC	DW	16	1000	RoHS & Green	Call TI	Level-3-260C-168 HR	-40 to 85	INA111AU	Samples
INA111BP	ACTIVE	PDIP	P	8	50	RoHS & Green	NIPDAU	N / A for Pkg Type		INA111BP	Samples
INA111BU	ACTIVE	SOIC	DW	16	40	RoHS & Green	NIPDAU	Level-3-260C-168 HR		INA111BU	Samples

(1) The marketing status values are defined as follows:

ACTIVE: Product device recommended for new designs.

LIFEBUY: TI has announced that the device will be discontinued, and a lifetime-buy period is in effect.

NRND: Not recommended for new designs. Device is in production to support existing customers, but TI does not recommend using this part in a new design.

PREVIEW: Device has been announced but is not in production. Samples may or may not be available.

OBSELETE: TI has discontinued the production of the device.

(2) **RoHS:** TI defines "RoHS" to mean semiconductor products that are compliant with the current EU RoHS requirements for all 10 RoHS substances, including the requirement that RoHS substance do not exceed 0.1% by weight in homogeneous materials. Where designed to be soldered at high temperatures, "RoHS" products are suitable for use in specified lead-free processes. TI may reference these types of products as "Pb-Free".

RoHS Exempt: TI defines "RoHS Exempt" to mean products that contain lead but are compliant with EU RoHS pursuant to a specific EU RoHS exemption.

Green: TI defines "Green" to mean the content of Chlorine (Cl) and Bromine (Br) based flame retardants meet JS709B low halogen requirements of <=1000ppm threshold. Antimony trioxide based flame retardants must also meet the <=1000ppm threshold requirement.

(3) MSL, Peak Temp. - The Moisture Sensitivity Level rating according to the JEDEC industry standard classifications, and peak solder temperature.

(4) There may be additional marking, which relates to the logo, the lot trace code information, or the environmental category on the device.

(5) Multiple Device Markings will be inside parentheses. Only one Device Marking contained in parentheses and separated by a "~" will appear on a device. If a line is indented then it is a continuation of the previous line and the two combined represent the entire Device Marking for that device.

(6) Lead finish/Ball material - Orderable Devices may have multiple material finish options. Finish options are separated by a vertical ruled line. Lead finish/Ball material values may wrap to two lines if the finish value exceeds the maximum column width.

Important Information and Disclaimer: The information provided on this page represents TI's knowledge and belief as of the date that it is provided. TI bases its knowledge and belief on information provided by third parties, and makes no representation or warranty as to the accuracy of such information. Efforts are underway to better integrate information from third parties. TI has taken and continues to take reasonable steps to provide representative and accurate information but may not have conducted destructive testing or chemical analysis on incoming materials and chemicals. TI and TI suppliers consider certain information to be proprietary, and thus CAS numbers and other limited information may not be available for release.

In no event shall TI's liability arising out of such information exceed the total purchase price of the TI part(s) at issue in this document sold by TI to Customer on an annual basis.

TAPE AND REEL INFORMATION

QUADRANT ASSIGNMENTS FOR PIN 1 ORIENTATION IN TAPE

*All dimensions are nominal

Device	Package Type	Package Drawing	Pins	SPQ	Reel Diameter (mm)	Reel Width W1 (mm)	A0 (mm)	B0 (mm)	K0 (mm)	P1 (mm)	W (mm)	Pin1 Quadrant
INA111AU/1K	SOIC	DW	16	1000	330.0	16.4	10.75	10.7	2.7	12.0	16.0	Q1

TAPE AND REEL BOX DIMENSIONS

*All dimensions are nominal

Device	Package Type	Package Drawing	Pins	SPQ	Length (mm)	Width (mm)	Height (mm)
INA111AU/1K	SOIC	DW	16	1000	356.0	356.0	35.0

TUBE

*All dimensions are nominal

Device	Package Name	Package Type	Pins	SPQ	L (mm)	W (mm)	T (μm)	B (mm)
INA111AP	P	PDIP	8	50	506	13.97	11230	4.32
INA111AU	DW	SOIC	16	40	507	12.83	5080	6.6
INA111BP	P	PDIP	8	50	506	13.97	11230	4.32
INA111BU	DW	SOIC	16	40	507	12.83	5080	6.6

IMPORTANT NOTICE AND DISCLAIMER

TI PROVIDES TECHNICAL AND RELIABILITY DATA (INCLUDING DATA SHEETS), DESIGN RESOURCES (INCLUDING REFERENCE DESIGNS), APPLICATION OR OTHER DESIGN ADVICE, WEB TOOLS, SAFETY INFORMATION, AND OTHER RESOURCES "AS IS" AND WITH ALL FAULTS, AND DISCLAIMS ALL WARRANTIES, EXPRESS AND IMPLIED, INCLUDING WITHOUT LIMITATION ANY IMPLIED WARRANTIES OF MERCHANTABILITY, FITNESS FOR A PARTICULAR PURPOSE OR NON-INFRINGEMENT OF THIRD PARTY INTELLECTUAL PROPERTY RIGHTS.

These resources are intended for skilled developers designing with TI products. You are solely responsible for (1) selecting the appropriate TI products for your application, (2) designing, validating and testing your application, and (3) ensuring your application meets applicable standards, and any other safety, security, regulatory or other requirements.

These resources are subject to change without notice. TI grants you permission to use these resources only for development of an application that uses the TI products described in the resource. Other reproduction and display of these resources is prohibited. No license is granted to any other TI intellectual property right or to any third party intellectual property right. TI disclaims responsibility for, and you will fully indemnify TI and its representatives against, any claims, damages, costs, losses, and liabilities arising out of your use of these resources.

TI's products are provided subject to [TI's Terms of Sale](#) or other applicable terms available either on [ti.com](https://www.ti.com) or provided in conjunction with such TI products. TI's provision of these resources does not expand or otherwise alter TI's applicable warranties or warranty disclaimers for TI products.

TI objects to and rejects any additional or different terms you may have proposed.

Mailing Address: Texas Instruments, Post Office Box 655303, Dallas, Texas 75265
Copyright © 2024, Texas Instruments Incorporated

Looking for pricing, stock, or lifecycle information?

Click below to explore more details on WIN SOURCE:

 [View INA111AP](#) on WIN SOURCE

 [Texas Instruments](#) Information

Optimize Your Supply Chain with WIN SOURCE Solutions

-  Global Sourcing Solution
-  Obsolete Management
-  Cost Control Management
-  Shortage Management
-  Alternative Solution
-  Excess Inventory Management