



**THE DATASHEET OF  
M74HCT4066ADTR2G**



# Quad Analog Switch/ Multiplexer/Demultiplexer with LSTTL Compatible Inputs

High-Performance Silicon-Gate CMOS

## MC74HCT4066A

The MC74HCT4066A utilizes silicon-gate CMOS technology to achieve fast propagation delays, low ON resistances, and low OFF-channel leakage current. This bilateral switch/multiplexer/demultiplexer controls analog and digital voltages that may vary across the full power-supply range (from  $V_{CC}$  to GND).

The HCT4066A is identical in pinout to the metal-gate CMOS MC14016 and MC14066. Each device has four independent switches. The device has been designed so the ON resistances ( $R_{ON}$ ) are more linear over input voltage than  $R_{ON}$  of metal-gate CMOS analog switches.

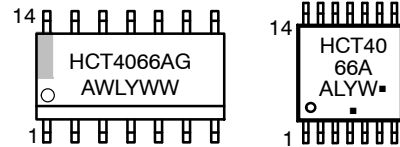
The ON/OFF control inputs are compatible with standard CMOS and LSTTL outputs. For analog switches with voltage-level translators, see the HC4316A.

### Features

- Fast Switching and Propagation Speeds
- High ON/OFF Output Voltage Ratio
- Low Crosstalk Between Switches
- Diode Protection on All Inputs/Outputs
- Wide Power-Supply Voltage Range ( $V_{CC} - GND$ ) = 4.5 to 5.5 V
- Analog Input Voltage Range ( $V_{CC} - GND$ ) = 0 to 5.5 V
- Improved Linearity and Lower ON Resistance over Input Voltage than the MC14016 or MC14066
- Low Noise
- Chip Complexity: 44 FETs or 11 Equivalent Gates
- These are Pb-Free Devices



### MARKING DIAGRAM



- A = Assembly Location
- L, WL = Wafer Lot
- Y, YY = Year
- W, WW = Work Week
- G or ■ = Pb-Free Package

(Note: Microdot may be in either location)

### ORDERING INFORMATION

See detailed ordering and shipping information in the package dimensions section on page 2 of this data sheet.

NOTE: Some of the device on this data sheet have been **DISCONTINUED**. Please refer to the table on page 2

# MC74HCT4066A

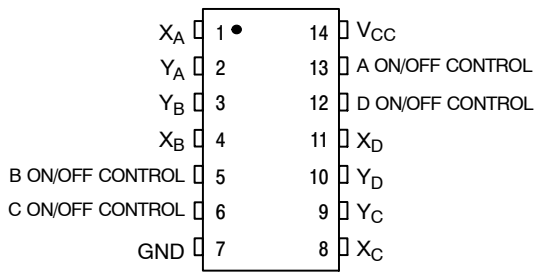
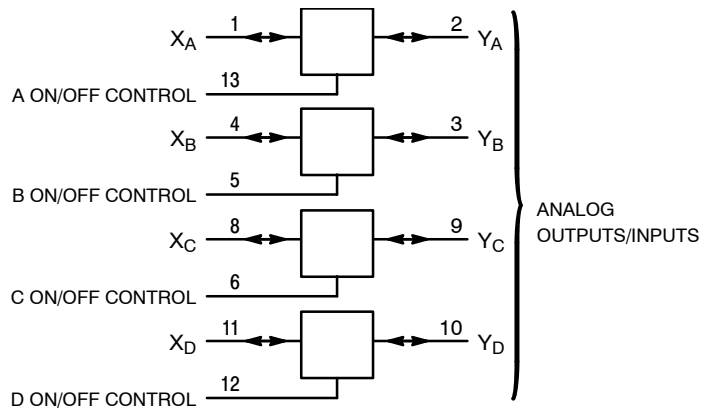


Figure 1. Pin Assignment

### FUNCTION TABLE

On/Off Control Input	State of Analog Switch
L	Off
H	On



ANALOG INPUTS/OUTPUTS = X<sub>A</sub>, X<sub>B</sub>, X<sub>C</sub>, X<sub>D</sub>  
 PIN 14 = V<sub>CC</sub>  
 PIN 7 = GND

Figure 2. Logic Diagram

### ORDERING INFORMATION

Device	Package	Shipping <sup>†</sup>
MC74HCT4066ADG	SOIC-14 (Pb-Free)	55 Units / Rail

### DISCONTINUED (Note 1)

Device	Package	Shipping <sup>†</sup>
MC74HCT4066ADR2G	SOIC-14 (Pb-Free)	2500 / Tape & Reel
MC74HCT4066ADTR2G	TSSOP-14*	2500 / Tape & Reel

<sup>†</sup>For information on tape and reel specifications, including part orientation and tape sizes, please refer to our Tape and Reel Packaging Specifications Brochure, [BRD8011/D](#).

1. **DISCONTINUED:** This device is not recommended for new design. Please contact your **onsemi** representative for information. The most current information on this device may be available on [www.onsemi.com](http://www.onsemi.com).

\*NLV Prefix for Automotive and Other Applications Requiring Unique Site and Control Change Requirements; AEC-Q100 Qualified and PPAP Capable.

# MC74HCT4066A

## MAXIMUM RATINGS

Symbol	Parameter	Value	Unit
$V_{CC}$	Positive DC Supply Voltage (Referenced to GND)	-0.5 to +14.0	V
$V_{IS}$	Analog Input Voltage (Referenced to GND)	-0.5 to $V_{CC} + 0.5$	V
$V_{in}$	Digital Input Voltage (Referenced to GND)	-0.5 to $V_{CC} + 0.5$	V
I	DC Current Into or Out of Any Pin	$\pm 25$	mA
$P_D$	Power Dissipation in Still Air, SOIC Package† TSSOP Package†	500 450	mW
$T_{stg}$	Storage Temperature	-65 to +150	°C

Stresses exceeding Maximum Ratings may damage the device. Maximum Ratings are stress ratings only. Functional operation above the Recommended Operating Conditions is not implied. Extended exposure to stresses above the Recommended Operating Conditions may affect device reliability.

†Derating – SOIC Package: - 7 mW/°C from 65°C to 125°C  
TSSOP Package: - 6.1 mW/°C from 65°C to 125°C

This device contains protection circuitry to guard against damage due to high static voltages or electric fields. However, precautions must be taken to avoid applications of any voltage higher than maximum rated voltages to this high-impedance circuit. For proper operation,  $V_{in}$  and  $V_{out}$  should be constrained to the range  $GND \leq (V_{in} \text{ or } V_{out}) \leq V_{CC}$ . Unused inputs must always be tied to an appropriate logic voltage level (e.g., either GND or  $V_{CC}$ ). Unused outputs must be left open. I/O pins must be connected to a properly terminated line or bus.

## RECOMMENDED OPERATING CONDITIONS

Symbol	Parameter	Min	Max	Unit
$V_{CC}$	Positive DC Supply Voltage (Referenced to GND)	4.5	5.5	V
$V_{IS}$	Analog Input Voltage (Referenced to GND)	GND	$V_{CC}$	V
$V_{in}$	Digital Input Voltage (Referenced to GND)	GND	$V_{CC}$	V
$V_{IO}^*$	Static or Dynamic Voltage Across Switch	-	1.2	V
$T_A$	Operating Temperature, All Package Types	-55	+125	°C
$t_r, t_f$	Input Rise and Fall Time, ON/OFF Control Inputs (Figure 10)	$V_{CC} = 4.5 \text{ V}$ 0	500	ns

\*For voltage drops across the switch greater than 1.2 V (switch on), excessive  $V_{CC}$  current may be drawn; i.e., the current out of the switch may contain both  $V_{CC}$  and switch input components. The reliability of the device will be unaffected unless the Maximum Ratings are exceeded.

## DC ELECTRICAL CHARACTERISTIC Digital Section (Voltages Referenced to GND)

Symbol	Parameter	Test Conditions	$V_{CC}$ V	Guaranteed Limit			Unit
				- 55 to 25°C	≤ 85°C	≤ 125°C	
$V_{IH}$	Minimum High-Level Voltage ON/OFF Control Inputs	$R_{on} = \text{Per Spec}$	4.5 to 5.5	2.0	2.0	2.0	V
$V_{IL}$	Maximum Low-Level Voltage ON/OFF Control Inputs	$R_{on} = \text{Per Spec}$	4.5 to 5.5	0.8	0.8	0.8	V
$I_{in}$	Maximum Input Leakage Current ON/OFF Control Inputs	$V_{in} = V_{CC} \text{ or } GND$	5.5	$\pm 0.1$	$\pm 1.0$	$\pm 1.0$	$\mu A$
$I_{CC}$	Maximum Quiescent Supply Current (per Package)	$V_{in} = V_{CC} \text{ or } GND$ $V_{IO} = 0 \text{ V}$	5.5	2	20	40	$\mu A$
$\Delta I_{CC}$	Additional Quiescent Supply Current (per Input)	$V_{in} = V_{CC} - 2.1 \text{ V}$ Other control inputs at $V_{CC}$ or GND	4.5 to 5.5	360	450	490	$\mu A$

# MC74HCT4066A

## DC ELECTRICAL CHARACTERISTICS Analog Section (Voltages Referenced to GND)

Symbol	Parameter	Test Conditions	V <sub>CC</sub> V	Guaranteed Limit			Unit
				- 55 to 25°C	≤ 85°C	≤ 125°C	
R <sub>on</sub>	Maximum "ON" Resistance	V <sub>in</sub> = V <sub>IH</sub> V <sub>IS</sub> = V <sub>CC</sub> to GND I <sub>S</sub> ≤ 2.0 mA (Figures 3, 4)	4.5	120	160	200	Ω
		V <sub>in</sub> = V <sub>IH</sub> V <sub>IS</sub> = V <sub>CC</sub> or GND (Endpoints) I <sub>S</sub> ≤ 2.0 mA (Figures 3, 4)	4.5	70	85	120	
ΔR <sub>on</sub>	Maximum Difference in "ON" Resistance Between Any Two Channels in the Same Package	V <sub>in</sub> = V <sub>IH</sub> V <sub>IS</sub> = 1/2 (V <sub>CC</sub> - GND) I <sub>S</sub> ≤ 2.0 mA	4.5	20	25	30	Ω
I <sub>off</sub>	Maximum Off-Channel Leakage Current, Any One Channel	V <sub>in</sub> = V <sub>IL</sub> V <sub>IO</sub> = V <sub>CC</sub> or GND Switch Off (Figure 5)	5.5	0.1	0.5	1.0	μA
I <sub>on</sub>	Maximum On-Channel Leakage Current, Any One Channel	V <sub>in</sub> = V <sub>IH</sub> V <sub>IS</sub> = V <sub>CC</sub> or GND (Figure 6)	5.5	0.1	0.5	1.0	μA

## AC ELECTRICAL CHARACTERISTICS (C<sub>L</sub> = 50 pF, ON/OFF Control Inputs: t<sub>r</sub> = t<sub>f</sub> = 6 ns)

Symbol	Parameter	V <sub>CC</sub> V	Guaranteed Limit			Unit	
			- 55 to 25°C	≤ 85°C	≤ 125°C		
t <sub>PLH</sub> , t <sub>PHL</sub>	Maximum Propagation Delay, Analog Input to Analog Output (Figures 10 and 11)	4.5	10	13	15	ns	
t <sub>PLZ</sub> , t <sub>PHZ</sub>	Maximum Propagation Delay, ON/OFF Control to Analog Output (Figures 12 and 13)	4.5	30	38	45	ns	
t <sub>PZL</sub> , t <sub>PZH</sub>	Maximum Propagation Delay, ON/OFF Control to Analog Output (Figures 12 and 13)	4.5	25	32	37	ns	
C	Maximum Capacitance	ON/OFF Control Input	-	10	10	10	pF
		Control Input = GND	-	35	35	35	
		Analog I/O Feedthrough	-	1.0	1.0	1.0	

C <sub>PD</sub>	Power Dissipation Capacitance (Per Switch) (Figure 15)*	Typical @ 25°C, V <sub>CC</sub> = 5.0 V		pF
		15		

\*Used to determine the no-load dynamic power consumption: P<sub>D</sub> = C<sub>PD</sub> V<sub>CC</sub><sup>2</sup>f + I<sub>CC</sub> V<sub>CC</sub>.

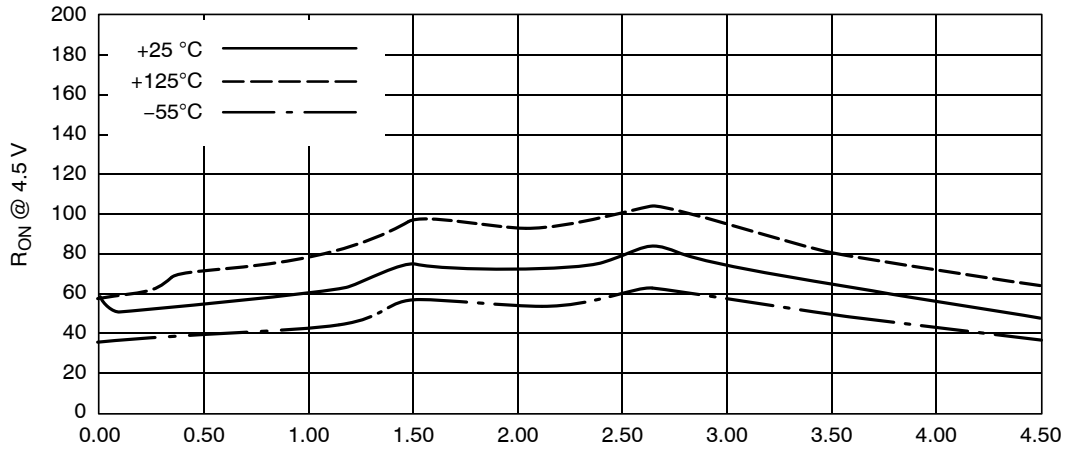
# MC74HCT4066A

## ADDITIONAL APPLICATION CHARACTERISTICS (Voltages Referenced to GND Unless Noted)

Symbol	Parameter	Test Conditions	V <sub>CC</sub> V	Limit* 25°C 54/74HCT	Unit
BW	Maximum On-Channel Bandwidth or Minimum Frequency Response (Figure 7)	f <sub>in</sub> = 1 MHz Sine Wave Adjust f <sub>in</sub> Voltage to Obtain 0 dBm at V <sub>OS</sub> Increase f <sub>in</sub> Frequency Until dB Meter Reads - 3 dB R <sub>L</sub> = 50 Ω, C <sub>L</sub> = 10 pF	4.5	150	MHz
-	Off-Channel Feedthrough Isolation (Figure 8)	f <sub>in</sub> ≡ Sine Wave Adjust f <sub>in</sub> Voltage to Obtain 0 dBm at V <sub>IS</sub> f <sub>in</sub> = 10 kHz, R <sub>L</sub> = 600 Ω, C <sub>L</sub> = 50 pF	4.5	-50	dB
		f <sub>in</sub> = 1.0 MHz, R <sub>L</sub> = 50 Ω, C <sub>L</sub> = 10 pF	4.5	-40	
-	Feedthrough Noise, Control to Switch (Figure 9)	V <sub>in</sub> ≤ 1 MHz Square Wave (t <sub>r</sub> = t <sub>f</sub> = 6 ns) Adjust R <sub>L</sub> at Setup so that I <sub>S</sub> = 0 A R <sub>L</sub> = 600 Ω, C <sub>L</sub> = 50 pF	4.5	60	mV <sub>PP</sub>
		R <sub>L</sub> = 10 kΩ, C <sub>L</sub> = 10 pF	4.5	30	
-	Crosstalk Between Any Two Switches (Figure 14)	f <sub>in</sub> ≡ Sine Wave Adjust f <sub>in</sub> Voltage to Obtain 0 dBm at V <sub>IS</sub> f <sub>in</sub> = 10 kHz, R <sub>L</sub> = 600 Ω, C <sub>L</sub> = 50 pF	4.5	-70	dB
		f <sub>in</sub> = 1.0 MHz, R <sub>L</sub> = 50 Ω, C <sub>L</sub> = 10 pF	4.5	-80	
THD	Total Harmonic Distortion (Figure 16)	f <sub>in</sub> = 1 kHz, R <sub>L</sub> = 10 kΩ, C <sub>L</sub> = 50 pF THD = THD <sub>Measured</sub> - THD <sub>Source</sub> V <sub>IS</sub> = 4.0 V <sub>PP</sub> sine wave	4.5	0.10	%

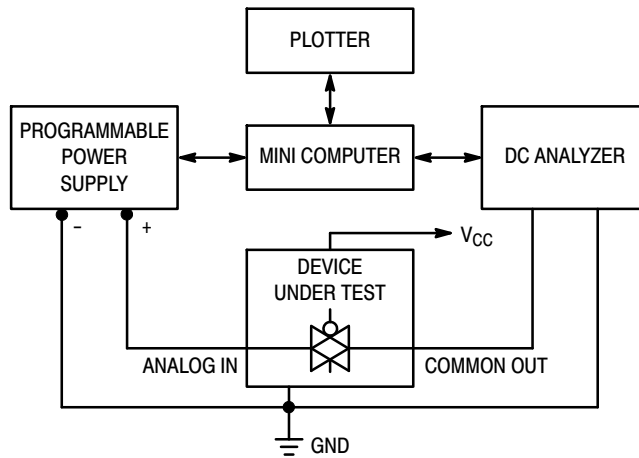
\*Guaranteed limits not tested. Determined by design and verified by qualification.

# MC74HCT4066A

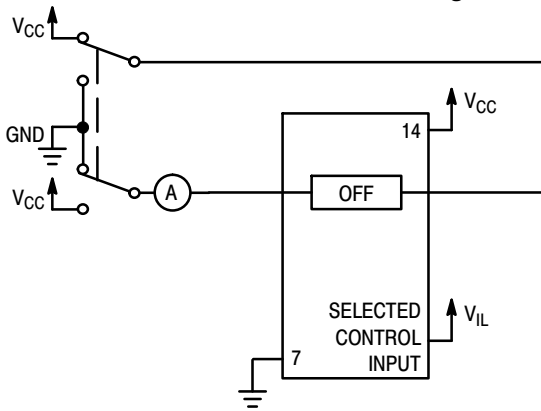


$V_{iS}$ , INPUT VOLTAGE (VOLTS), REFERENCED TO GROUND

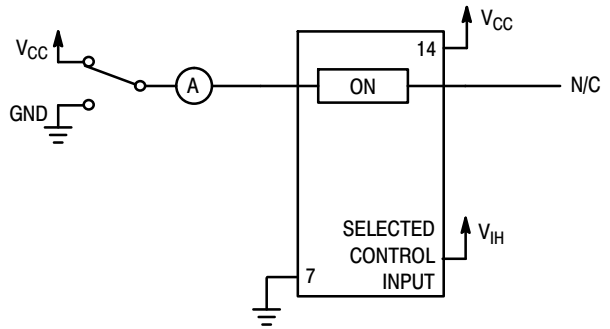
**Figure 3. Typical On Resistance,  $V_{CC} = 4.5 V$**



**Figure 4. On Resistance Test Set-Up**

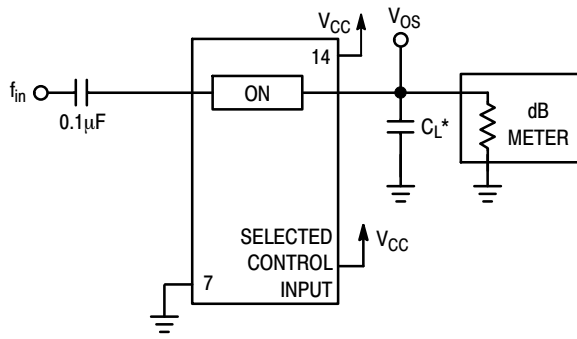


**Figure 5. Maximum Off Channel Leakage Current, Any One Channel, Test Set-Up**



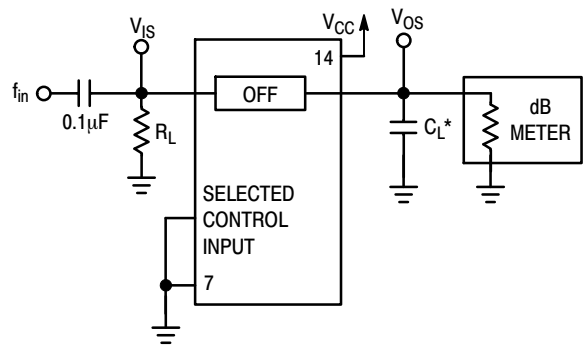
**Figure 6. Maximum On Channel Leakage Current, Test Set-Up**

# MC74HCT4066A



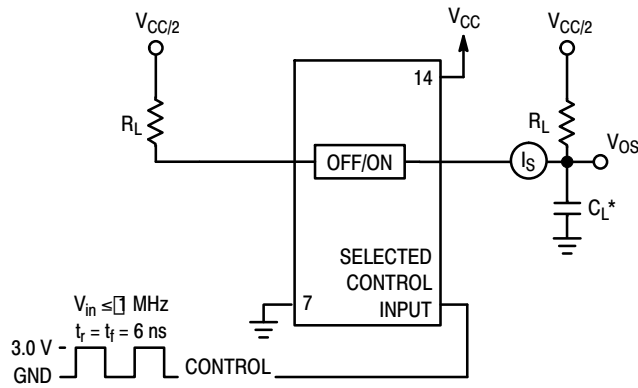
\*Includes all probe and jig capacitance.

**Figure 7. Maximum On-Channel Bandwidth Test Set-Up**



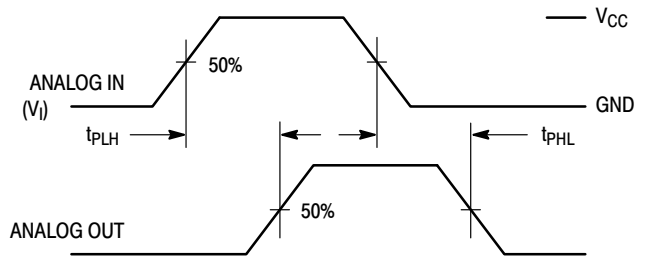
\*Includes all probe and jig capacitance.

**Figure 8. Off-Channel Feedthrough Isolation, Test Set-Up**



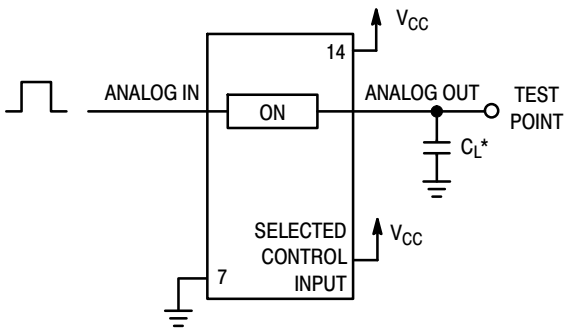
\*Includes all probe and jig capacitance.

**Figure 9. Feedthrough Noise, ON/OFF Control to Analog Out, Test Set-Up**



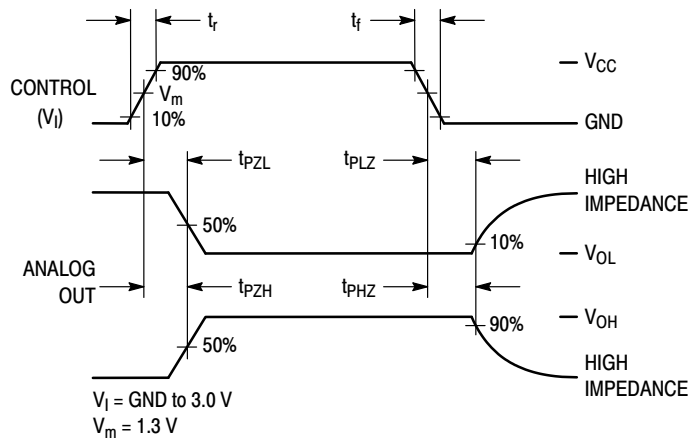
**Figure 10. Propagation Delays, Analog In to Analog Out**

# MC74HCT4066A

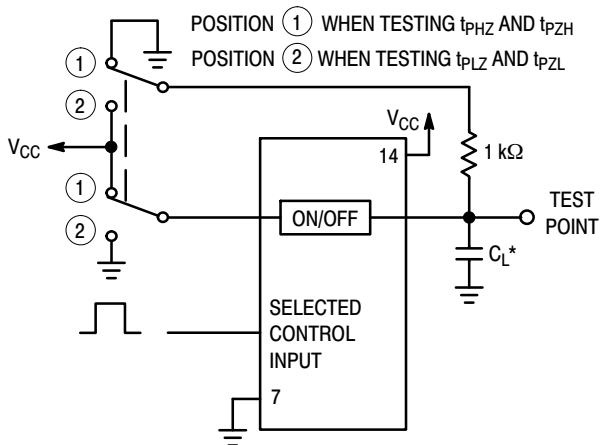


\*Includes all probe and jig capacitance.

**Figure 11. Propagation Delay Test Set-Up**

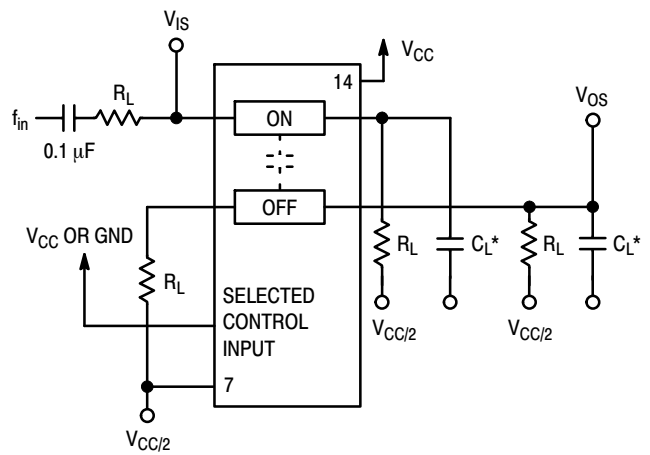


**Figure 12. Propagation Delay, ON/OFF Control to Analog Out**



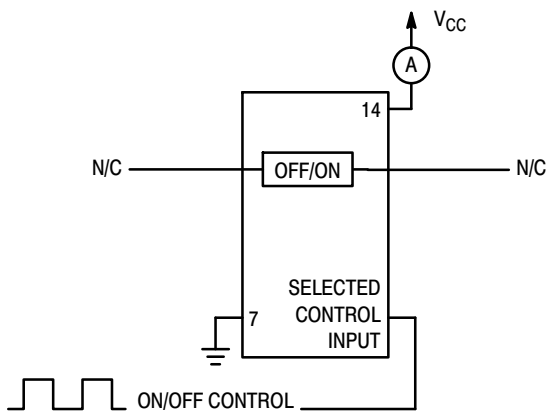
\*Includes all probe and jig capacitance.

**Figure 13. Propagation Delay Test Set-Up**

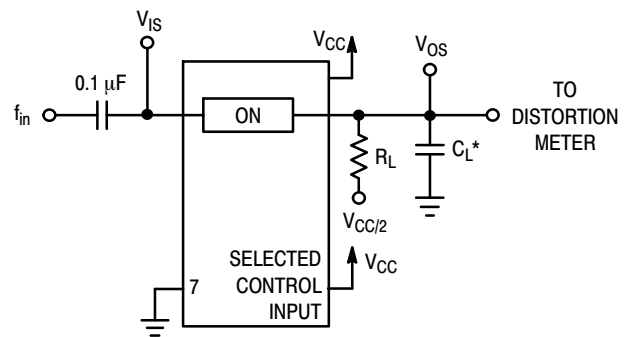


\*Includes all probe and jig capacitance.

**Figure 14. Crosstalk Between Any Two Switches, Test Set-Up**



**Figure 15. Power Dissipation Capacitance Test Set-Up**



\*Includes all probe and jig capacitance.

**Figure 16. Total Harmonic Distortion, Test Set-Up**

# MC74HCT4066A

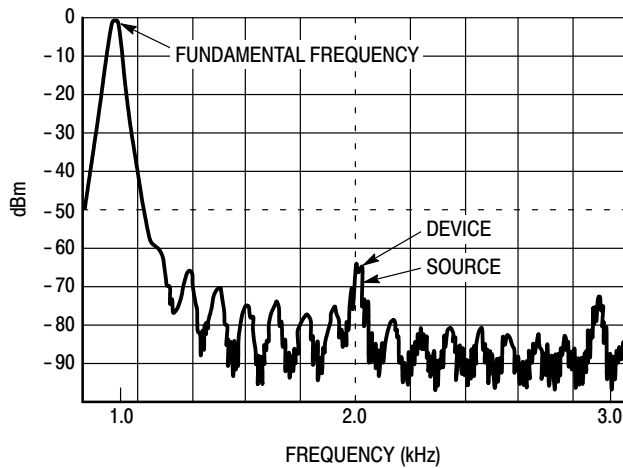


Figure 17. Plot, Harmonic Distortion

## APPLICATION INFORMATION

Unused analog inputs/outputs may be left floating (not connected). However, it is advisable to tie unused analog inputs and outputs to  $V_{CC}$  or GND through a low value resistor. This minimizes crosstalk and feedthrough noise that may be picked-up by the unused I/O pins.

The maximum analog voltage swings are determined by the supply voltages  $V_{CC}$  and GND. The positive peak analog voltage should not exceed  $V_{CC}$ . Similarly, the negative peak analog voltage should not go below GND. In the example below, the difference between  $V_{CC}$  and GND is twelve volts. Therefore, using the configuration in Figure 16, a maximum

analog signal of twelve volts peak-to-peak can be controlled.

When voltage transients above  $V_{CC}$  and/or below GND are anticipated on the analog channels, external diodes ( $D_x$ ) are recommended as shown in Figure 17. These diodes should be small signal, fast turn-on types able to absorb the maximum anticipated current surges during clipping. An alternate method would be to replace the  $D_x$  diodes with MOSORB® (MOSORB is an acronym for high current surge protectors). MOSORBs are fast turn-on devices ideally suited for precise DC protection with no inherent wear out mechanism.

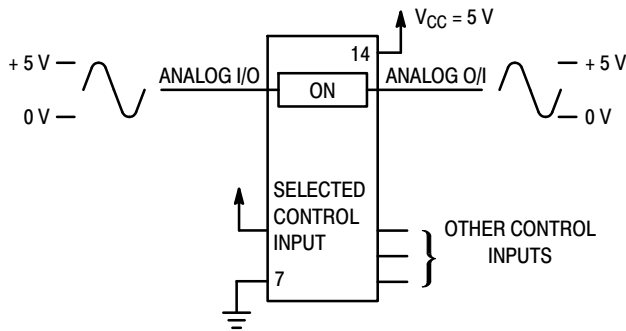


Figure 18. 5 V Application

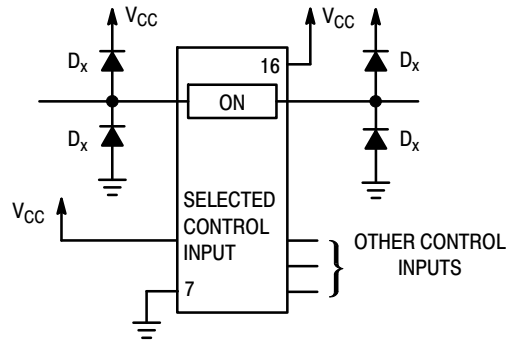
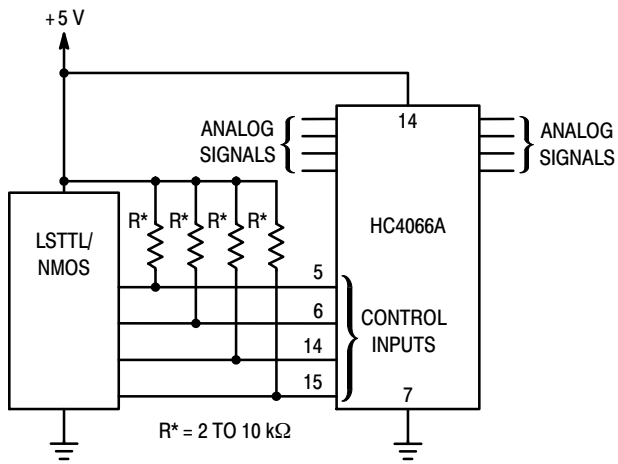
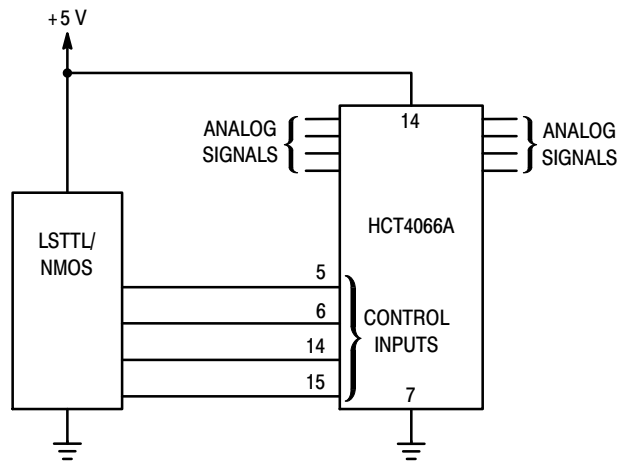


Figure 19. Transient Suppressor Application

# MC74HCT4066A



a. Using Pull-Up Resistors with HC Device



b. Using HCT Buffer

Figure 20. LSTTL/NMOS to HCTMOS Interface

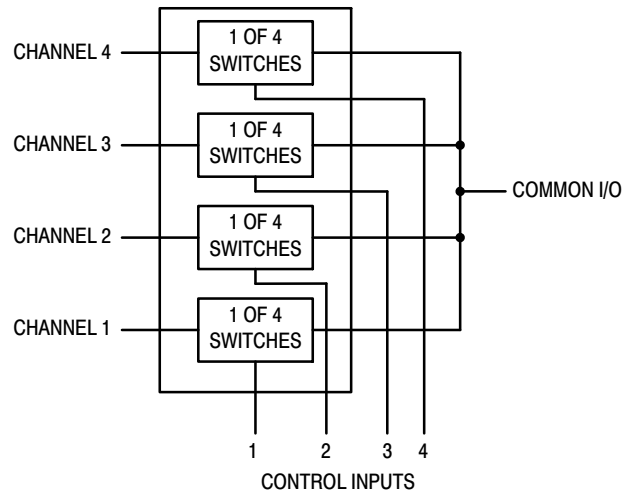


Figure 21. 4-Input Multiplexer

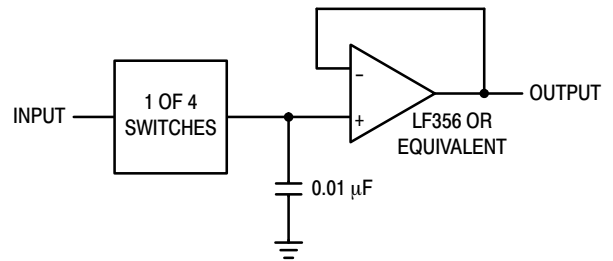
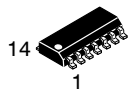


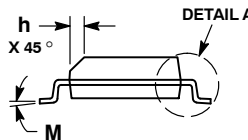
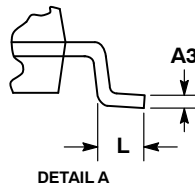
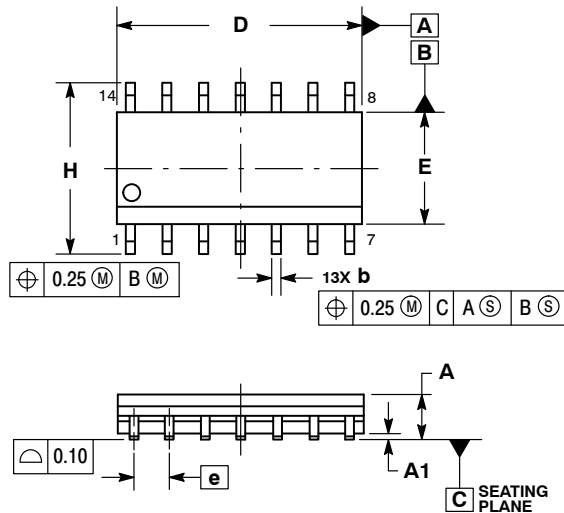
Figure 22. Sample/Hold Amplifier



SCALE 1:1

SOIC-14 NB  
CASE 751A-03  
ISSUE L

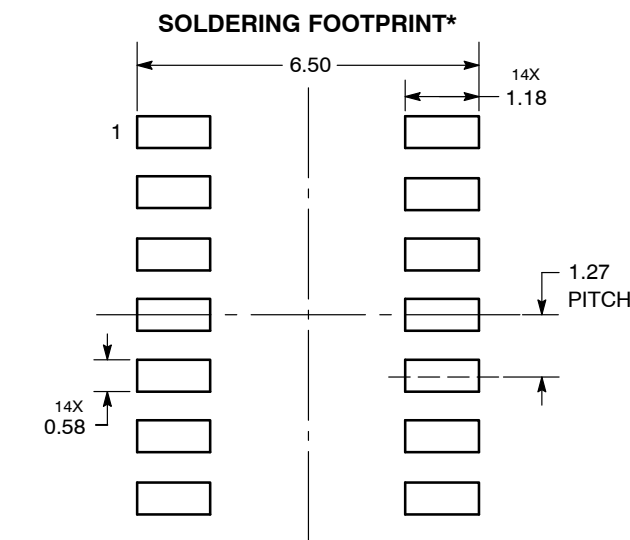
DATE 03 FEB 2016



NOTES:

1. DIMENSIONING AND TOLERANCING PER ASME Y14.5M, 1994.
2. CONTROLLING DIMENSION: MILLIMETERS.
3. DIMENSION b DOES NOT INCLUDE DAMBAR PROTRUSION. ALLOWABLE PROTRUSION SHALL BE 0.13 TOTAL IN EXCESS OF AT MAXIMUM MATERIAL CONDITION.
4. DIMENSIONS D AND E DO NOT INCLUDE MOLD PROTRUSIONS.
5. MAXIMUM MOLD PROTRUSION 0.15 PER SIDE.

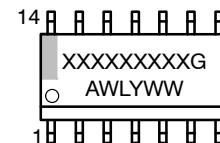
DIM	MILLIMETERS		INCHES	
	MIN	MAX	MIN	MAX
A	1.35	1.75	0.054	0.068
A1	0.10	0.25	0.004	0.010
A3	0.19	0.25	0.008	0.010
b	0.35	0.49	0.014	0.019
D	8.55	8.75	0.337	0.344
E	3.80	4.00	0.150	0.157
e	1.27 BSC		0.050 BSC	
H	5.80	6.20	0.228	0.244
h	0.25	0.50	0.010	0.019
L	0.40	1.25	0.016	0.049
M	0°	7°	0°	7°



DIMENSIONS: MILLIMETERS

\*For additional information on our Pb-Free strategy and soldering details, please download the onsemi Soldering and Mounting Techniques Reference Manual, SOLDERRM/D.

GENERIC MARKING DIAGRAM\*



- XXXXXX = Specific Device Code
- A = Assembly Location
- WL = Wafer Lot
- Y = Year
- WW = Work Week
- G = Pb-Free Package

\*This information is generic. Please refer to device data sheet for actual part marking. Pb-Free indicator, "G" or microdot "▪", may or may not be present. Some products may not follow the Generic Marking.

STYLES ON PAGE 2

DOCUMENT NUMBER:	98ASB42565B	Electronic versions are uncontrolled except when accessed directly from the Document Repository. Printed versions are uncontrolled except when stamped "CONTROLLED COPY" in red.
DESCRIPTION:	SOIC-14 NB	PAGE 1 OF 2

onsemi and onsemi are trademarks of Semiconductor Components Industries, LLC dba onsemi or its subsidiaries in the United States and/or other countries. onsemi reserves the right to make changes without further notice to any products herein. onsemi makes no warranty, representation or guarantee regarding the suitability of its products for any particular purpose, nor does onsemi assume any liability arising out of the application or use of any product or circuit, and specifically disclaims any and all liability, including without limitation special, consequential or incidental damages. onsemi does not convey any license under its patent rights nor the rights of others.

**SOIC-14**  
**CASE 751A-03**  
**ISSUE L**

DATE 03 FEB 2016

STYLE 1:  
 PIN 1. COMMON CATHODE  
 2. ANODE/CATHODE  
 3. ANODE/CATHODE  
 4. NO CONNECTION  
 5. ANODE/CATHODE  
 6. NO CONNECTION  
 7. ANODE/CATHODE  
 8. ANODE/CATHODE  
 9. ANODE/CATHODE  
 10. NO CONNECTION  
 11. ANODE/CATHODE  
 12. ANODE/CATHODE  
 13. NO CONNECTION  
 14. COMMON ANODE

STYLE 2:  
 CANCELLED

STYLE 3:  
 PIN 1. NO CONNECTION  
 2. ANODE  
 3. ANODE  
 4. NO CONNECTION  
 5. ANODE  
 6. NO CONNECTION  
 7. ANODE  
 8. ANODE  
 9. ANODE  
 10. NO CONNECTION  
 11. ANODE  
 12. ANODE  
 13. NO CONNECTION  
 14. COMMON CATHODE

STYLE 4:  
 PIN 1. NO CONNECTION  
 2. CATHODE  
 3. CATHODE  
 4. NO CONNECTION  
 5. CATHODE  
 6. NO CONNECTION  
 7. CATHODE  
 8. CATHODE  
 9. CATHODE  
 10. NO CONNECTION  
 11. CATHODE  
 12. CATHODE  
 13. NO CONNECTION  
 14. COMMON ANODE

STYLE 5:  
 PIN 1. COMMON CATHODE  
 2. ANODE/CATHODE  
 3. ANODE/CATHODE  
 4. ANODE/CATHODE  
 5. ANODE/CATHODE  
 6. NO CONNECTION  
 7. COMMON ANODE  
 8. COMMON CATHODE  
 9. ANODE/CATHODE  
 10. ANODE/CATHODE  
 11. ANODE/CATHODE  
 12. ANODE/CATHODE  
 13. NO CONNECTION  
 14. COMMON ANODE

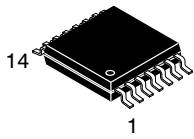
STYLE 6:  
 PIN 1. CATHODE  
 2. CATHODE  
 3. CATHODE  
 4. CATHODE  
 5. CATHODE  
 6. CATHODE  
 7. CATHODE  
 8. ANODE  
 9. ANODE  
 10. ANODE  
 11. ANODE  
 12. ANODE  
 13. ANODE  
 14. ANODE

STYLE 7:  
 PIN 1. ANODE/CATHODE  
 2. COMMON ANODE  
 3. COMMON CATHODE  
 4. ANODE/CATHODE  
 5. ANODE/CATHODE  
 6. ANODE/CATHODE  
 7. ANODE/CATHODE  
 8. ANODE/CATHODE  
 9. ANODE/CATHODE  
 10. ANODE/CATHODE  
 11. COMMON CATHODE  
 12. COMMON ANODE  
 13. ANODE/CATHODE  
 14. ANODE/CATHODE

STYLE 8:  
 PIN 1. COMMON CATHODE  
 2. ANODE/CATHODE  
 3. ANODE/CATHODE  
 4. NO CONNECTION  
 5. ANODE/CATHODE  
 6. ANODE/CATHODE  
 7. COMMON ANODE  
 8. COMMON ANODE  
 9. ANODE/CATHODE  
 10. ANODE/CATHODE  
 11. NO CONNECTION  
 12. ANODE/CATHODE  
 13. ANODE/CATHODE  
 14. COMMON CATHODE

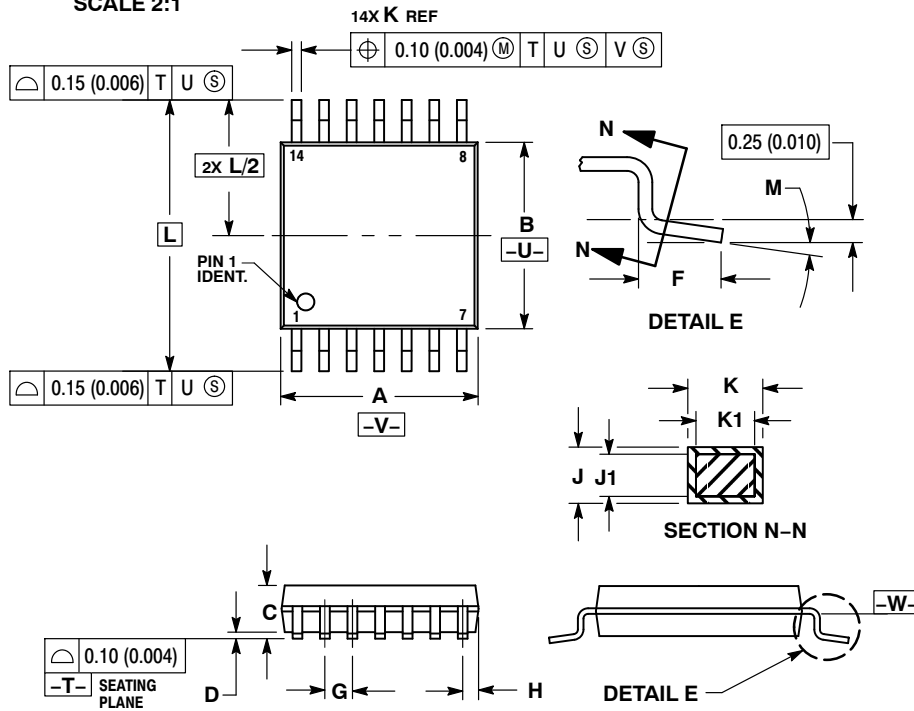
<b>DOCUMENT NUMBER:</b>	<b>98ASB42565B</b>	Electronic versions are uncontrolled except when accessed directly from the Document Repository. Printed versions are uncontrolled except when stamped "CONTROLLED COPY" in red.
<b>DESCRIPTION:</b>	<b>SOIC-14 NB</b>	<b>PAGE 2 OF 2</b>

**onsemi** and **ONSEMI** are trademarks of Semiconductor Components Industries, LLC dba **onsemi** or its subsidiaries in the United States and/or other countries. **onsemi** reserves the right to make changes without further notice to any products herein. **onsemi** makes no warranty, representation or guarantee regarding the suitability of its products for any particular purpose, nor does **onsemi** assume any liability arising out of the application or use of any product or circuit, and specifically disclaims any and all liability, including without limitation special, consequential or incidental damages. **onsemi** does not convey any license under its patent rights nor the rights of others.



TSSOP-14 WB  
CASE 948G  
ISSUE C

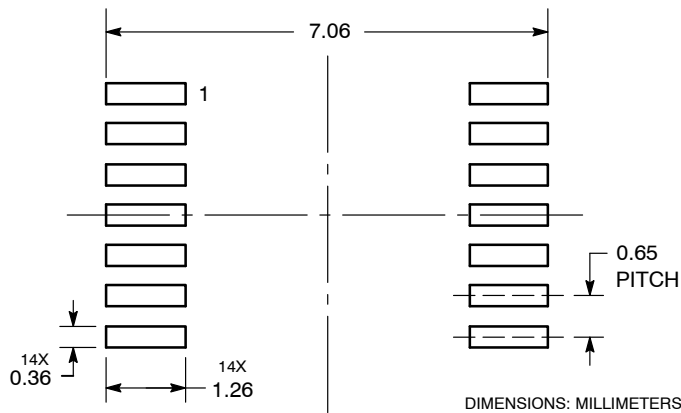
DATE 17 FEB 2016



- NOTES:
- DIMENSIONING AND TOLERANCING PER ANSI Y14.5M, 1982.
  - CONTROLLING DIMENSION: MILLIMETER.
  - DIMENSION A DOES NOT INCLUDE MOLD FLASH, PROTRUSIONS OR GATE BURRS. MOLD FLASH OR GATE BURRS SHALL NOT EXCEED 0.15 (0.006) PER SIDE.
  - DIMENSION B DOES NOT INCLUDE INTERLEAD FLASH OR PROTRUSION. INTERLEAD FLASH OR PROTRUSION SHALL NOT EXCEED 0.25 (0.010) PER SIDE.
  - DIMENSION K DOES NOT INCLUDE DAMBAR PROTRUSION. ALLOWABLE DAMBAR PROTRUSION SHALL BE 0.08 (0.003) TOTAL IN EXCESS OF THE K DIMENSION AT MAXIMUM MATERIAL CONDITION.
  - TERMINAL NUMBERS ARE SHOWN FOR REFERENCE ONLY.
  - DIMENSION A AND B ARE TO BE DETERMINED AT DATUM PLANE -W-.

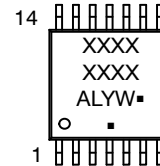
DIM	MILLIMETERS		INCHES	
	MIN	MAX	MIN	MAX
A	4.90	5.10	0.193	0.200
B	4.30	4.50	0.169	0.177
C	---	1.20	---	0.047
D	0.05	0.15	0.002	0.006
F	0.50	0.75	0.020	0.030
G	0.65 BSC		0.026 BSC	
H	0.50	0.60	0.020	0.024
J	0.09	0.20	0.004	0.008
J1	0.09	0.16	0.004	0.006
K	0.19	0.30	0.007	0.012
K1	0.19	0.25	0.007	0.010
L	6.40 BSC		0.252 BSC	
M	0°	8°	0°	8°

RECOMMENDED  
SOLDERING FOOTPRINT\*



\*For additional information on our Pb-Free strategy and soldering details, please download the onsemi Soldering and Mounting Techniques Reference Manual, SOLDERRM/D.

GENERIC  
MARKING DIAGRAM\*



- A = Assembly Location
- L = Wafer Lot
- Y = Year
- W = Work Week
- = Pb-Free Package

(Note: Microdot may be in either location)

\*This information is generic. Please refer to device data sheet for actual part marking. Pb-Free indicator, "G" or microdot "▪", may or may not be present. Some products may not follow the Generic Marking.

DOCUMENT NUMBER:	98ASH70246A	Electronic versions are uncontrolled except when accessed directly from the Document Repository. Printed versions are uncontrolled except when stamped "CONTROLLED COPY" in red.
DESCRIPTION:	TSSOP-14 WB	PAGE 1 OF 1

onsemi and onsemi are trademarks of Semiconductor Components Industries, LLC dba onsemi or its subsidiaries in the United States and/or other countries. onsemi reserves the right to make changes without further notice to any products herein. onsemi makes no warranty, representation or guarantee regarding the suitability of its products for any particular purpose, nor does onsemi assume any liability arising out of the application or use of any product or circuit, and specifically disclaims any and all liability, including without limitation special, consequential or incidental damages. onsemi does not convey any license under its patent rights nor the rights of others.

**onsemi**, **Onsemi**, and other names, marks, and brands are registered and/or common law trademarks of Semiconductor Components Industries, LLC dba "**onsemi**" or its affiliates and/or subsidiaries in the United States and/or other countries. **onsemi** owns the rights to a number of patents, trademarks, copyrights, trade secrets, and other intellectual property. A listing of **onsemi**'s product/patent coverage may be accessed at [www.onsemi.com/site/pdf/Patent-Marking.pdf](http://www.onsemi.com/site/pdf/Patent-Marking.pdf). **onsemi** reserves the right to make changes at any time to any products or information herein, without notice. The information herein is provided "as-is" and **onsemi** makes no warranty, representation or guarantee regarding the accuracy of the information, product features, availability, functionality, or suitability of its products for any particular purpose, nor does **onsemi** assume any liability arising out of the application or use of any product or circuit, and specifically disclaims any and all liability, including without limitation special, consequential or incidental damages. Buyer is responsible for its products and applications using **onsemi** products, including compliance with all laws, regulations and safety requirements or standards, regardless of any support or applications information provided by **onsemi**. "Typical" parameters which may be provided in **onsemi** data sheets and/or specifications can and do vary in different applications and actual performance may vary over time. All operating parameters, including "Typicals" must be validated for each customer application by customer's technical experts. **onsemi** does not convey any license under any of its intellectual property rights nor the rights of others. **onsemi** products are not designed, intended, or authorized for use as a critical component in life support systems or any FDA Class 3 medical devices or medical devices with a same or similar classification in a foreign jurisdiction or any devices intended for implantation in the human body. Should Buyer purchase or use **onsemi** products for any such unintended or unauthorized application, Buyer shall indemnify and hold **onsemi** and its officers, employees, subsidiaries, affiliates, and distributors harmless against all claims, costs, damages, and expenses, and reasonable attorney fees arising out of, directly or indirectly, any claim of personal injury or death associated with such unintended or unauthorized use, even if such claim alleges that **onsemi** was negligent regarding the design or manufacture of the part. **onsemi** is an Equal Opportunity/Affirmative Action Employer. This literature is subject to all applicable copyright laws and is not for resale in any manner.

## ADDITIONAL INFORMATION

### TECHNICAL PUBLICATIONS:

Technical Library: [www.onsemi.com/design/resources/technical-documentation](http://www.onsemi.com/design/resources/technical-documentation)  
onsemi Website: [www.onsemi.com](http://www.onsemi.com)

### ONLINE SUPPORT: [www.onsemi.com/support](http://www.onsemi.com/support)

For additional information, please contact your local Sales Representative at [www.onsemi.com/support/sales](http://www.onsemi.com/support/sales)

## Looking for pricing, stock, or lifecycle information?

Click below to explore more details on WIN SOURCE:

 [View M74HCT4066ADTR2G on WIN SOURCE](#)

 [ON Semiconductor](#) Information

## Optimize Your Supply Chain with WIN SOURCE Solutions

-  Global Sourcing Solution
-  Obsolete Management
-  Cost Control Management
-  Shortage Management
-  Alternative Solution
-  Excess Inventory Management