



**THE DATASHEET OF  
MC10EL12DTR2G**



# MC10EL12, MC100EL12

## 5.0 V ECL Low Impedance Driver

The MC10EL/100EL12 is a low impedance drive buffer. With two pairs of OR/NOR outputs the device is ideally suited for high drive applications such as memory addressing. The device is a function equivalent to the E112 device with higher performance capabilities. With propagation delays significantly faster than the E112, the EL12 is ideally suited for those applications which require the ultimate in AC performance.

The 100 Series contains temperature compensation.

### Features

- 290 ps Propagation Delay
- Dual Outputs for 25  $\Omega$  Drive Applications
- ESD Protection: Human Body Model; > 1.0 kV  
Machine Model; > 100 V
- PECL Mode Operating Range:  $V_{CC} = 4.2$  V to 5.7 V with  $V_{EE} = 0$  V
- NECL Mode Operating Range:  $V_{CC} = 0$  V with  $V_{EE} = -4.2$  V to  $-5.7$  V
- Internal Input Pulldown Resistors
- Meets or Exceeds JEDEC Spec EIA/JESD78 IC Latchup Test
- Moisture Sensitivity Level 1
- For Additional Information, see Application Note AND8003/D
- Flammability Rating: UL 94 V-0 @ 0.125 in,  
Oxygen Index: 28 to 34
- Transistor Count = 44 devices
- Pb-Free Packages are Available

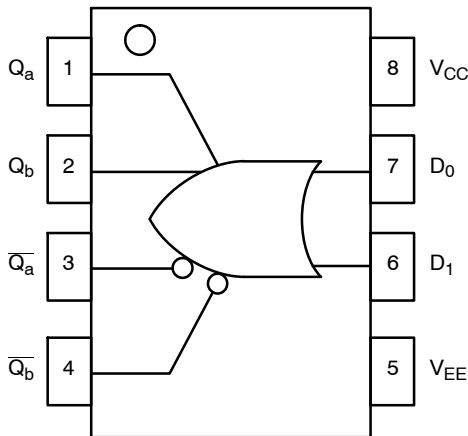

Figure 1. Logic Diagram and Pinout Assignment



ON Semiconductor®

<http://onsemi.com>

### MARKING DIAGRAMS\*

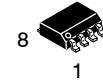

SOIC-8  
D SUFFIX  
CASE 751

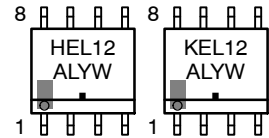

TSSOP-8  
DT SUFFIX  
CASE 948R

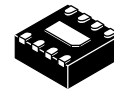
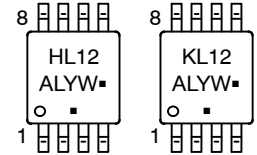

DFN8  
MN SUFFIX  
CASE 506AA

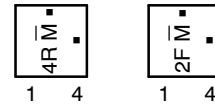

H	MC10	L	= Wafer Lot
K	MC100	Y	= Year
4R	MC10	W	= Work Week
2F	MC100	M	= Date Code
A	= Assembly Location	■	= Pb-Free Package

(Note: Microdot may be in either location)

\*For additional marking information, refer to Application Note AND8002/D.

### ORDERING INFORMATION

See detailed ordering and shipping information in the package dimensions section on page 5 of this data sheet.

# MC10EL12, MC100EL12

**Table 1. PIN DESCRIPTION**

PIN	FUNCTION
D0, D1	ECL Data Inputs
Qa, $\overline{Qa}$ ; Qb, $\overline{Qb}$	ECL Data Outputs
V <sub>CC</sub>	Positive Supply
V <sub>EE</sub>	Negative Supply
EP	(DFN8 only) Thermal exposed pad must be connected to a sufficient thermal conduit. Electrically connect to the most negative supply (GND) or leave unconnected, floating open.

**Table 2. MAXIMUM RATINGS**

Symbol	Parameter	Condition 1	Condition 2	Rating	Unit
V <sub>CC</sub>	PECL Mode Power Supply	V <sub>EE</sub> = 0 V		8	V
V <sub>EE</sub>	NECL Mode Power Supply	V <sub>CC</sub> = 0 V		-8	V
V <sub>I</sub>	PECL Mode Input Voltage NECL Mode Input Voltage	V <sub>EE</sub> = 0 V V <sub>CC</sub> = 0 V	V <sub>I</sub> ≤ V <sub>CC</sub> V <sub>I</sub> ≥ V <sub>EE</sub>	6 -6	V V
I <sub>out</sub>	Output Current	Continuous Surge		50 100	mA mA
T <sub>A</sub>	Operating Temperature Range			-40 to +85	°C
T <sub>stg</sub>	Storage Temperature Range			-65 to +150	°C
θ <sub>JA</sub>	Thermal Resistance (Junction-to-Ambient)	0 lfpm 500 lfpm	SOIC-8 SOIC-8	190 130	°C/W °C/W
θ <sub>JC</sub>	Thermal Resistance (Junction-to-Case)	Standard Board	SOIC-8	41 to 44	°C/W
θ <sub>JA</sub>	Thermal Resistance (Junction-to-Ambient)	0 lfpm 500 lfpm	TSSOP-8 TSSOP-8	185 140	°C/W °C/W
θ <sub>JC</sub>	Thermal Resistance (Junction-to-Case)	Standard Board	TSSOP-8	41 to 44 ± 5%	°C/W
θ <sub>JA</sub>	Thermal Resistance (Junction-to-Ambient)	0 lfpm 500 lfpm	DFN8 DFN8	129 84	°C/W °C/W
T <sub>sol</sub>	Wave Solder	Pb Pb-Free	<2 to 3 sec @ 248°C <2 to 3 sec @ 260°C	265 265	°C
θ <sub>JC</sub>	Thermal Resistance (Junction-to-Case)	(Note 1)	DFN8	35 to 40	°C/W

Stresses exceeding Maximum Ratings may damage the device. Maximum Ratings are stress ratings only. Functional operation above the Recommended Operating Conditions is not implied. Extended exposure to stresses above the Recommended Operating Conditions may affect device reliability.

1. JEDEC standard multilayer board – 2S2P (2 signal, 2 power)

## MC10EL12, MC100EL12

**Table 3. 10EL SERIES PECL DC CHARACTERISTICS**  $V_{CC}= 5.0\text{ V}$ ;  $V_{EE}= 0.0\text{ V}$  (Note 2)

Symbol	Characteristic	-40°C			25°C			85°C			Unit
		Min	Typ	Max	Min	Typ	Max	Min	Typ	Max	
$I_{EE}$	Power Supply Current		14	17		14	17		14	17	mA
$V_{OH}$	Output HIGH Voltage (Note 5)	3920	4010	4110	4020	4105	4190	4090	4185	4280	mV
$V_{OL}$	Output LOW Voltage (Note 3)	3050	3200	3350	3050	3210	3370	3050	3227	3405	mV
$V_{IH}$	Input HIGH Voltage	3770		4110	3870		4190	3940		4280	mV
$V_{IL}$	Input LOW Voltage	3050		3500	3050		3520	3050		3555	mV
$I_{IH}$	Input HIGH Current			150			150			150	$\mu\text{A}$
$I_{IL}$	Input LOW Current	0.5			0.5			0.3			$\mu\text{A}$

NOTE: Device will meet the specifications after thermal equilibrium has been established when mounted in a test socket or printed circuit board with maintained transverse airflow greater than 500 lfpm. Electrical parameters are guaranteed only over the declared operating temperature range. Functional operation of the device exceeding these conditions is not implied. Device specification limit values are applied individually under normal operating conditions and not valid simultaneously.

2. Input and output parameters vary 1:1 with  $V_{CC}$ .  $V_{EE}$  can vary +0.06 V / -0.5 V.
3. Outputs are terminated through a 50  $\Omega$  resistor to  $V_{CC} - 2$  volts.

**Table 4. 10EL SERIES NECL DC CHARACTERISTICS**  $V_{CC}= 0.0\text{ V}$ ;  $V_{EE}= -5.0\text{ V}$  (Note 4)

Symbol	Characteristic	-40°C			25°C			85°C			Unit
		Min	Typ	Max	Min	Typ	Max	Min	Typ	Max	
$I_{EE}$	Power Supply Current		14	17		14	17		14	17	mA
$V_{OH}$	Output HIGH Voltage (Note 5)	-1080	-990	-890	-980	-895	-810	-910	-815	-720	mV
$V_{OL}$	Output LOW Voltage (Note 5)	-1950	-1800	-1650	-1950	-1790	-1630	-1950	-1773	-1595	mV
$V_{IH}$	Input HIGH Voltage	-1230		-890	-1130		-810	-1060		-720	mV
$V_{IL}$	Input LOW Voltage	-1950		-1500	-1950		-1480	-1950		-1445	mV
$I_{IH}$	Input HIGH Current			150			150			150	$\mu\text{A}$
$I_{IL}$	Input LOW Current	0.5			0.5			0.3			$\mu\text{A}$

NOTE: Device will meet the specifications after thermal equilibrium has been established when mounted in a test socket or printed circuit board with maintained transverse airflow greater than 500 lfpm. Electrical parameters are guaranteed only over the declared operating temperature range. Functional operation of the device exceeding these conditions is not implied. Device specification limit values are applied individually under normal operating conditions and not valid simultaneously.

4. Input and output parameters vary 1:1 with  $V_{CC}$ .  $V_{EE}$  can vary +0.06 V / -0.5 V.
5. Outputs are terminated through a 50  $\Omega$  resistor to  $V_{CC} - 2$  volts.

**Table 5. 100EL SERIES PECL DC CHARACTERISTICS**  $V_{CC}= 5.0\text{ V}$ ;  $V_{EE}= 0.0\text{ V}$  (Note 6)

Symbol	Characteristic	-40°C			25°C			85°C			Unit
		Min	Typ	Max	Min	Typ	Max	Min	Typ	Max	
$I_{EE}$	Power Supply Current		14	17		14	17		16	20	mA
$V_{OH}$	Output HIGH Voltage (Note 7)	3915	3995	4120	3975	4045	4120	3975	4050	4120	mV
$V_{OL}$	Output LOW Voltage (Note 7)	3170	3305	3445	3190	3295	3380	3190	3295	3380	mV
$V_{IH}$	Input HIGH Voltage	3835		4120	3835		4120	3835		4120	mV
$V_{IL}$	Input LOW Voltage	3190		3525	3190		3525	3190		3525	mV
$I_{IH}$	Input HIGH Current			150			150			150	$\mu\text{A}$
$I_{IL}$	Input LOW Current	0.5			0.5			0.5			$\mu\text{A}$

NOTE: Device will meet the specifications after thermal equilibrium has been established when mounted in a test socket or printed circuit board with maintained transverse airflow greater than 500 lfpm. Electrical parameters are guaranteed only over the declared operating temperature range. Functional operation of the device exceeding these conditions is not implied. Device specification limit values are applied individually under normal operating conditions and not valid simultaneously.

6. Input and output parameters vary 1:1 with  $V_{CC}$ .  $V_{EE}$  can vary +0.8 V / -0.5 V.
7. Outputs are terminated through a 50  $\Omega$  resistor to  $V_{CC} - 2$  volts.

# MC10EL12, MC100EL12

**Table 6. 100EL SERIES NECL DC CHARACTERISTICS**  $V_{CC}= 0.0\text{ V}$ ;  $V_{EE}= -5.0\text{ V}$  (Note 8)

Symbol	Characteristic	-40°C			25°C			85°C			Unit
		Min	Typ	Max	Min	Typ	Max	Min	Typ	Max	
$I_{EE}$	Power Supply Current		14	17		14	17		16	20	mA
$V_{OH}$	Output HIGH Voltage (Note 9)	-1085	-1005	-880	-1025	-955	-880	-1025	-955	-880	mV
$V_{OL}$	Output LOW Voltage (Note 9)	-1830	-1695	-1555	-1810	-1705	-1620	-1810	-1705	-1620	mV
$V_{IH}$	Input HIGH Voltage	-1165		-880	-1165		-880	-1165		-880	mV
$V_{IL}$	Input LOW Voltage	-1810		-1475	-1810		-1475	-1810		-1475	mV
$I_{IH}$	Input HIGH Current			150			150			150	$\mu\text{A}$
$I_{IL}$	Input LOW Current	0.5			0.5			0.5			$\mu\text{A}$

NOTE: Device will meet the specifications after thermal equilibrium has been established when mounted in a test socket or printed circuit board with maintained transverse airflow greater than 500 lfm. Electrical parameters are guaranteed only over the declared operating temperature range. Functional operation of the device exceeding these conditions is not implied. Device specification limit values are applied individually under normal operating conditions and not valid simultaneously.

8. Input and output parameters vary 1:1 with  $V_{CC}$ .  $V_{EE}$  can vary +0.8 V / -0.5 V.

9. Outputs are terminated through a 50  $\Omega$  resistor to  $V_{CC} - 2$  volts.

**Table 7. AC CHARACTERISTICS**  $V_{CC}= 5.0\text{ V}$ ;  $V_{EE}= 0.0\text{ V}$  or  $V_{CC}= 0.0\text{ V}$ ;  $V_{EE}= -5.0\text{ V}$  (Note 9)

Symbol	Characteristic	-40°C			25°C			85°C			Unit
		Min	Typ	Max	Min	Typ	Max	Min	Typ	Max	
$f_{max}$	Maximum Toggle Frequency		TBD			TBD			TBD		GHz
$t_{PLH}$ $t_{PHL}$	Propagation Delay to Output	120	280	500	180	290	450	210	320	480	ps
$t_{JITTER}$	Cycle-to-Cycle Jitter		TBD			TBD			TBD		ps
$t_r$ $t_f$	Output Rise/Fall Times Q (20% - 80%)	150	350	550	150	350	550	150	350	550	ps

NOTE: Device will meet the specifications after thermal equilibrium has been established when mounted in a test socket or printed circuit board with maintained transverse airflow greater than 500 lfm. Electrical parameters are guaranteed only over the declared operating temperature range. Functional operation of the device exceeding these conditions is not implied. Device specification limit values are applied individually under normal operating conditions and not valid simultaneously.

10.10 Series:  $V_{EE}$  can vary +0.06 V / -0.5 V.

100 Series:  $V_{EE}$  can vary +0.8 V / -0.5 V.

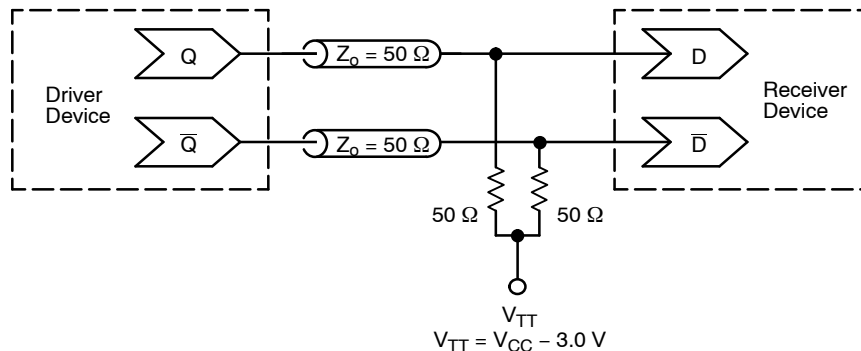

**Figure 2. Typical Termination for Output Driver and Device Evaluation**  
(See Application Note AND8020/D – Termination of ECL Logic Devices.)

## MC10EL12, MC100EL12

### ORDERING INFORMATION

Device	Package	Shipping†
MC10EL12D	SOIC-8	98 Units / Rail
MC10EL12DG	SOIC-8 (Pb-Free)	98 Units / Rail
MC10EL12DR2	SOIC-8	2500 / Tape & Reel
MC10EL12DR2G	SOIC-8 (Pb-Free)	2500 / Tape & Reel
MC10EL12DT	TSSOP-8	100 Units / Rail
MC10EL12DTG	TSSOP-8 (Pb-Free)	100 Units / Rail
MC10EL12DTR2	TSSOP-8	2500 / Tape & Reel
MC10EL12DTR2G	TSSOP-8 (Pb-Free)	2500 / Tape & Reel
MC10EL12MNR4	DFN8	1000 / Tape & Reel
MC10EL12MNR4G	DFN8 (Pb-Free)	1000 / Tape & Reel
MC100EL12D	SOIC-8	98 Units / Rail
MC100EL12DG	SOIC-8 (Pb-Free)	98 Units / Rail
MC100EL12DR2	SOIC-8	2500 / Tape & Reel
MC100EL12DR2G	SOIC-8 (Pb-Free)	2500 / Tape & Reel
MC100EL12DT	TSSOP-8	100 Units / Rail
MC100EL12DTG	TSSOP-8 (Pb-Free)	100 Units / Rail
MC100EL12DTR2	TSSOP-8	2500 / Tape & Reel
MC100EL12DTR2G	TSSOP-8 (Pb-Free)	2500 / Tape & Reel
MC100EL12MNR4	DFN8	1000 / Tape & Reel
MC100EL12MNR4G	DFN8 (Pb-Free)	1000 / Tape & Reel

†For information on tape and reel specifications, including part orientation and tape sizes, please refer to our Tape and Reel Packaging Specifications Brochure, BRD8011/D.

#### Resource Reference of Application Notes

- AN1405/D** – ECL Clock Distribution Techniques
- AN1406/D** – Designing with PECL (ECL at +5.0 V)
- AN1503/D** – ECLinPS™ I/O SPICE Modeling Kit
- AN1504/D** – Metastability and the ECLinPS Family
- AN1568/D** – Interfacing Between LVDS and ECL
- AN1672/D** – The ECL Translator Guide
- AND8001/D** – Odd Number Counters Design
- AND8002/D** – Marking and Date Codes
- AND8020/D** – Termination of ECL Logic Devices
- AND8066/D** – Interfacing with ECLinPS
- AND8090/D** – AC Characteristics of ECL Devices

# MC10EL12, MC100EL12

## PACKAGE DIMENSIONS

SOIC-8 NB  
CASE 751-07  
ISSUE AH

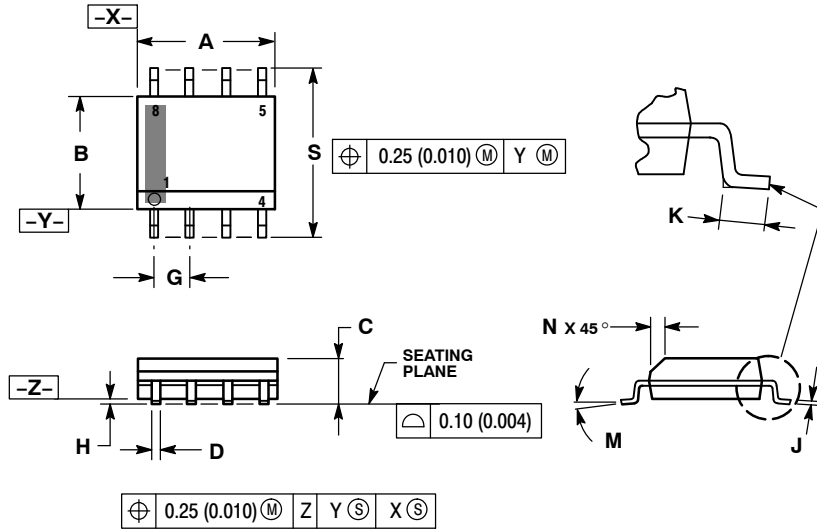

NOTES:

1. DIMENSIONING AND TOLERANCING PER ANSI Y14.5M, 1982.
2. CONTROLLING DIMENSION: MILLIMETER.
3. DIMENSION A AND B DO NOT INCLUDE MOLD PROTRUSION.
4. MAXIMUM MOLD PROTRUSION 0.15 (0.006) PER SIDE.
5. DIMENSION D DOES NOT INCLUDE DAMBAR PROTRUSION. ALLOWABLE DAMBAR PROTRUSION SHALL BE 0.127 (0.005) TOTAL IN EXCESS OF THE D DIMENSION AT MAXIMUM MATERIAL CONDITION.
6. 751-01 THRU 751-06 ARE OBSOLETE. NEW STANDARD IS 751-07.

DIM	MILLIMETERS		INCHES	
	MIN	MAX	MIN	MAX
A	4.80	5.00	0.189	0.197
B	3.80	4.00	0.150	0.157
C	1.35	1.75	0.053	0.069
D	0.33	0.51	0.013	0.020
G	1.27 BSC		0.050 BSC	
H	0.10	0.25	0.004	0.010
J	0.19	0.25	0.007	0.010
K	0.40	1.27	0.016	0.050
M	0°	8°	0°	8°
N	0.25	0.50	0.010	0.020
S	5.80	6.20	0.228	0.244

### SOLDERING FOOTPRINT\*

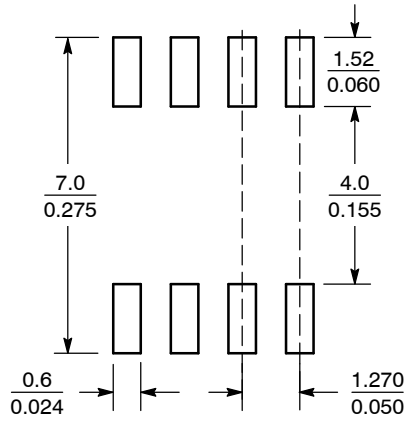

SCALE 6:1 (mm/inches)

\*For additional information on our Pb-Free strategy and soldering details, please download the ON Semiconductor Soldering and Mounting Techniques Reference Manual, SOLDERRM/D.

# MC10EL12, MC100EL12

## PACKAGE DIMENSIONS

TSSOP-8  
DT SUFFIX  
PLASTIC TSSOP PACKAGE  
CASE 948R-02  
ISSUE A

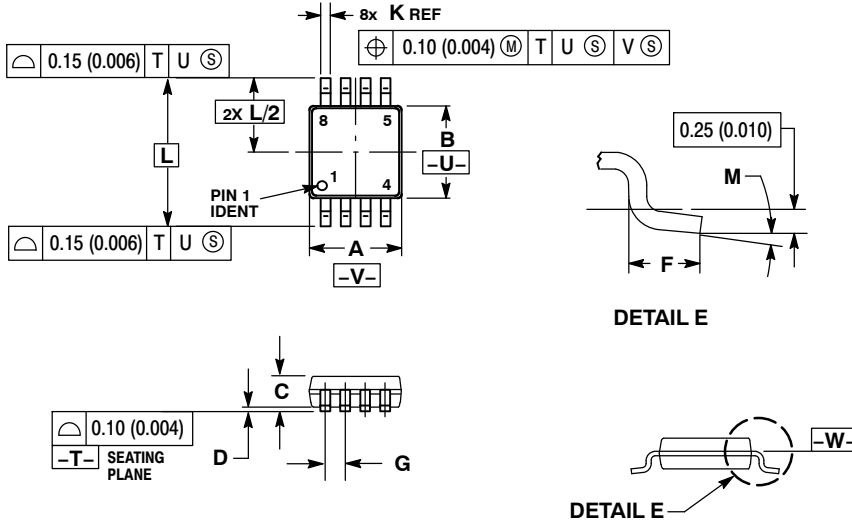

- NOTES:
1. DIMENSIONING AND TOLERANCING PER ANSI Y14.5M, 1982.
  2. CONTROLLING DIMENSION: MILLIMETER.
  3. DIMENSION A DOES NOT INCLUDE MOLD FLASH. PROTRUSIONS OR GATE BURRS. MOLD FLASH OR GATE BURRS SHALL NOT EXCEED 0.15 (0.006) PER SIDE.
  4. DIMENSION B DOES NOT INCLUDE INTERLEAD FLASH OR PROTRUSION. INTERLEAD FLASH OR PROTRUSION SHALL NOT EXCEED 0.25 (0.010) PER SIDE.
  5. TERMINAL NUMBERS ARE SHOWN FOR REFERENCE ONLY.
  6. DIMENSION A AND B ARE TO BE DETERMINED AT DATUM PLANE -W-.

DIM	MILLIMETERS		INCHES	
	MIN	MAX	MIN	MAX
A	2.90	3.10	0.114	0.122
B	2.90	3.10	0.114	0.122
C	0.80	1.10	0.031	0.043
D	0.05	0.15	0.002	0.006
F	0.40	0.70	0.016	0.028
G	0.65 BSC		0.026 BSC	
K	0.25	0.40	0.010	0.016
L	4.90 BSC		0.193 BSC	
M	0°	6°	0°	6°

# MC10EL12, MC100EL12

## PACKAGE DIMENSIONS

DFN8  
CASE 506AA-01  
ISSUE D

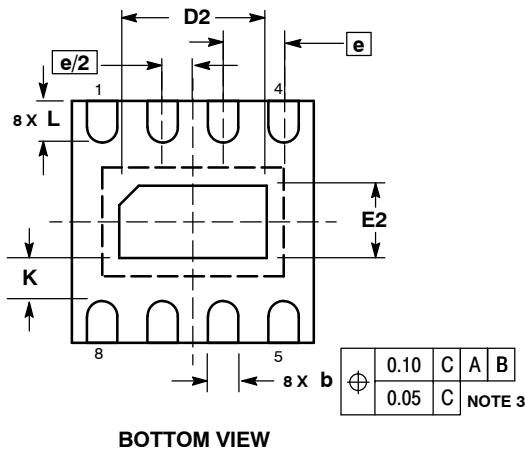
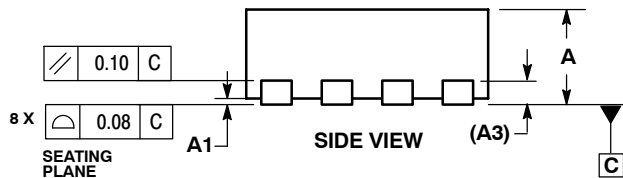
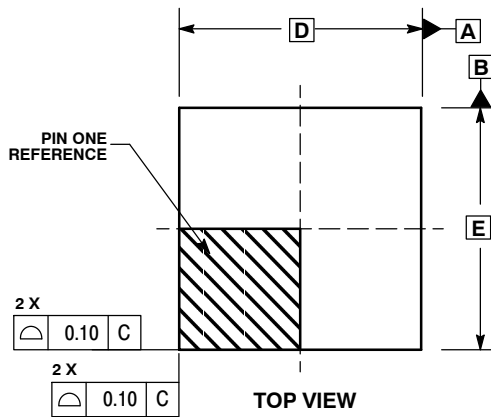

NOTES:

1. DIMENSIONING AND TOLERANCING PER ASME Y14.5M, 1994 .
2. CONTROLLING DIMENSION: MILLIMETERS.
3. DIMENSION b APPLIES TO PLATED TERMINAL AND IS MEASURED BETWEEN 0.25 AND 0.30 MM FROM TERMINAL
4. COPLANARITY APPLIES TO THE EXPOSED PAD AS WELL AS THE TERMINALS.

DIM	MILLIMETERS	
	MIN	MAX
A	0.80	1.00
A1	0.00	0.05
A3	0.20 REF	
b	0.20	0.30
D	2.00 BSC	
D2	1.10	1.30
E	2.00 BSC	
E2	0.70	0.90
e	0.50 BSC	
K	0.20	---
L	0.25	0.35

ECLinPS is a trademark of Semiconductor Components INdustries, LLC (SCILLC).

ON Semiconductor and are registered trademarks of Semiconductor Components Industries, LLC (SCILLC). SCILLC reserves the right to make changes without further notice to any products herein. SCILLC makes no warranty, representation or guarantee regarding the suitability of its products for any particular purpose, nor does SCILLC assume any liability arising out of the application or use of any product or circuit, and specifically disclaims any and all liability, including without limitation special, consequential or incidental damages. "Typical" parameters which may be provided in SCILLC data sheets and/or specifications can and do vary in different applications and actual performance may vary over time. All operating parameters, including "Typicals" must be validated for each customer application by customer's technical experts. SCILLC does not convey any license under its patent rights nor the rights of others. SCILLC products are not designed, intended, or authorized for use as components in systems intended for surgical implant into the body, or other applications intended to support or sustain life, or for any other application in which the failure of the SCILLC product could create a situation where personal injury or death may occur. Should Buyer purchase or use SCILLC products for any such unintended or unauthorized application, Buyer shall indemnify and hold SCILLC and its officers, employees, subsidiaries, affiliates, and distributors harmless against all claims, costs, damages, and expenses, and reasonable attorney fees arising out of, directly or indirectly, any claim of personal injury or death associated with such unintended or unauthorized use, even if such claim alleges that SCILLC was negligent regarding the design or manufacture of the part. SCILLC is an Equal Opportunity/Affirmative Action Employer. This literature is subject to all applicable copyright laws and is not for resale in any manner.

### PUBLICATION ORDERING INFORMATION

**LITERATURE FULFILLMENT:**  
Literature Distribution Center for ON Semiconductor  
P.O. Box 5163, Denver, Colorado 80217 USA  
**Phone:** 303-675-2175 or 800-344-3860 Toll Free USA/Canada  
**Fax:** 303-675-2176 or 800-344-3867 Toll Free USA/Canada  
**Email:** orderlit@onsemi.com

**N. American Technical Support:** 800-282-9855 Toll Free  
USA/Canada  
**Europe, Middle East and Africa Technical Support:**  
Phone: 421 33 790 2910  
**Japan Customer Focus Center**  
Phone: 81-3-5773-3850

**ON Semiconductor Website:** [www.onsemi.com](http://www.onsemi.com)  
**Order Literature:** <http://www.onsemi.com/orderlit>

For additional information, please contact your local Sales Representative

## Looking for pricing, stock, or lifecycle information?

Click below to explore more details on WIN SOURCE:

 [View MC10EL12DTR2G on WIN SOURCE](#)

 [ON Semiconductor](#) Information

## Optimize Your Supply Chain with WIN SOURCE Solutions

-  Global Sourcing Solution
-  Obsolete Management
-  Cost Control Management
-  Shortage Management
-  Alternative Solution
-  Excess Inventory Management