

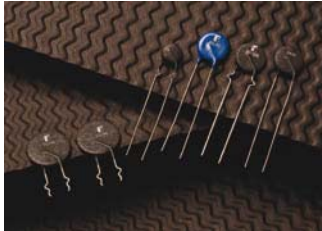

# THE DATASHEET OF SG170



You are here: [Home](#) > [Products](#) > [In-rush Current Limiters \(Surge-Gard\)](#)



## SURGE-GARD™ Circuit Protection Devices NTC Thermistors



### SURGE-GARD™ Features

- Lowers rectifier cost by reducing required peak forward surge current rating
- Reduces Noise
- Reduces Fuse Failures
- High Current Capability

### NTC Thermistors

Negative Temperature Coefficient (NTC) thermistors are thermally sensitive semiconductor resistors which exhibit a decrease in resistance as absolute temperature increases. Change in the resistance of the NTC thermistor can be brought about either by a change in the ambient temperature or internally by self-heating resulting from current flowing through the device. Most of the practical applications of NTC thermistors are based on these material characteristics.

### Inrush Current Limiting Devices

RTI manufactures SURGE-GARD™ Inrush current limiting devices using specially formulated metal oxide ceramic materials. These devices are capable of suppressing high inrush current surges. They are especially useful in power supplies where the low impedance of the charging capacitor exposes the diode bridge rectifier to an excessively high current surge at turn-on.

Thermistor Terminology for Inrush Current Limiting Devices

- $I_{MAX}$  - The maximum steady state RMS AC or DC current.
- $I_{OP}$  - The actual operating current.
- $R_{I_{MAX}}$  - The approximate resistance under maximum steady state current conditions.
- **MAX Operating Temperature** - RTI's recommended maximum ambient temperature is 65°C without de-rating. (Ref. Fig. C for de-rating information)
- **Recovery Time** - SURGE-GARD™ devices require time to return to their ambient resistance state in order to provide adequate inrush current limiting at each power turn-on. This time varies with each device, the mounting configuration and the ambient operating temperature. RTI recommends a minimum of 60 seconds. The selection of a capacitor bleeder resistor can reduce the required cool down time requirement.

### SURGE-GARD™ Selection Procedure

- Calculate  $I_{MAX}$
- Calculate  $R_{@25^{\circ}C}$
- Select SURGE-GARD™ specified to handle the input energy & maximum current with a  $R_{@25^{\circ}C}$  value capable of limiting the inrush current
- Evaluate Joules Rating

### Applications

RTI's SURGE-GARDs™ are used in many applications today that require limiting inrush current when power is applied to a system. The most popular application is the inrush protection of the AC current in switching power supplies (SPS). The primary reason for having surge current suppression in a SPS is to protect the diode bridge rectifier as the input or charging capacitor is initially charged. This capacitor draws significant current during the first half AC cycle and can subject the components in line with the capacitor to excessive current. The inherent equivalent series resistance (ESR) of the capacitor provides very little protection for the diode bridge rectifier. Use of the proper SURGE-GARD™ will provide maximum current protection when the power supply is turned on and allow the design engineer to select lower peak current rated diode bridge rectifiers for use in their SPS.

If the resistance of one SURGE-GARD™ does not provide sufficient inrush current limiting for an existing application, two or more may be used in series or in separate legs of the power supply circuit. SURGE-GARDs™ should not be used in parallel since one unit will tend to conduct nearly all the current available. SURGE-

- Calculate the **SURGE-GARD™** resistance at  $I_{OP}$  using the 'M' curve in Figure B
- Check Figure C if de-rating is required for high ambient operating temperature

**SURGE-GARD™**  
Installation  
Options

- Thru-hole Leads
- Insulated/Uninsulated
- Standoffs
- Preformed Leads
- See Figure D

**GARDs™** may be used in the AC input side or in the circuit on the DC line between the charging capacitors and the diode bridge rectifier circuit. (Reference Figure A)

**Selection Considerations for SURGE-GARDs™**

- **I<sub>MAX</sub>** - The first critical consideration in the selection of a **SURGE-GARD™** is the maximum steady state current (AC or DC) of the power supply. **SURGE-GARDs™** are rated for maximum continuous current. The input power (Pin) is calculated as  $P_{in} = P_{out}/\text{efficiency}$ . In the case of a 75 Watt SPS with 0.70 efficiency, 100% load is calculated to be 107.14 Watts. The maximum input current is at the minimum input voltage. The effective input current ( $I_e$ ) is equal to the maximum load divided by the minimum input voltage. In this case, a 75 Watt SPS,  $I_e = P_{in}/V_{in}^{(low)} = 107.14 \text{ Watts}/90 \text{ Volts} = 1.2 \text{ Amps}$ . Therefore, the **SURGE-GARD™** must have an  $I_{MAX}$  rating of at least 1.2 Amps.
- **R@25°C** - The second step is to determine the minimum R value of the **SURGE-GARD™** to be selected that will limit the one cycle maximum current rating of the diode bridge rectifier to 50% of its rating to ensure adequate surge protection. Several additional calculations must be made to determine the estimated resistance value required at the point in time of the maximum current surge. RTI provides for a maximum AC voltage rating of 265V RMS on most **SURGE-GARDs™**. (Reference the Specifications) If the desired maximum inrush current is less than 100 Amps (50% of the diode bridge with a peak current rating of 200 Amps), then solving for R would produce a value of 2.65 ohms. If the **MAX Operating Temperature** is other than 25°C then the zero power resistance value must be calculated using the **NTC Resistance/Temperature Conversion Tables**.

As an example, if the **MAX Operating Temp.** is 50°C, and the **SURGE-GARD™** selected has an **R-T Curve A**, the  $R_T/R_{25}$  factor is 0.464. This indicates in order for the **SURGE-GARD™** to have the same effective current limiting characteristic at the elevated temperature, it must have a higher resistance than the **R@25°C** value previously determined. To simplify our selection of the minimum R value divide the initial **R@25°C** value by the  $R_T/R_{25}$  factor. In this case, the **Minimum R@25°C value** =  $2.65 \text{ ohm}/0.464 = 5.71 \text{ ohms}$ .

- **Select a SURGE-GARD™** - The third requirement is to select a **SURGE-GARD™** from the **Specifications**. First find the column labeled **R@25°C**. The resistance values are listed in ascending order. If the exact R value calculated is not listed round up to the next highest R value. In this example that would be a 6 ohm, 5 Amp part, number SG418. Notice that the current rating is higher than required. This current rating is mass dependent therefore the part would be larger in size than the circuit requires. Continue down the column until the closest current rating is located. In this case it would be a 10 ohm, 3 Amp rated part, number SG220. This would be the selected **SURGE-GARD™** of choice.
- **Evaluate Joules Rating** - The fourth step is to review the amount of energy that can be absorbed or dissipated by a **SURGE-GARD™** before a failure may occur. The **SURGE-GARD™** devices are rated in **Joules**. In order to calculate the Joules rating the input capacitor value must be specified. Assume that the input capacitor is 220µfd. The instantaneous energy is equal to one half times the capacitance of the capacitor plus its tolerance times the peak voltage squared. In this example,  $E_i = 0.5 (220 (+/-)To) \cdot 10^{-6} \cdot (265 \cdot 1.414)^2 = 15.44 \text{ J}$  (nominal). The Joules rating for the SG220 selected is 17J. (Please note that other criteria such as hold up time, ripple current, capacitor discharge time, and the efficiency of the power supply design may affect the **SURGE-GARD™** selection process. Consult RTI's application engineering personnel for additional information.)
- **Calculate  $I_{OP}/I_{MAX}$  Ratio** - Next, estimate the actual operating current,  $I_{OP}$ , and calculate the  $I_{OP}/I_{MAX}$  ratio. The nominal resistance of a **SURGE-GARD™** when operated at its  $I_{MAX}$  rating is specified in the Specifications under the  $R_{I_{MAX}}$  heading. The device's resistance when it is operated at a current less than its  $I_{MAX}$  rating can be estimated by multiplying its  $R_{I_{MAX}}$  rating by the factor, **M**. As an example, a **SURGE-GARD™** with an  $I_{MAX}$  of 3.0 Amps and an  $R_{I_{MAX}}$  of 0.20 ohms that is operated at 1.2 Amps, the  $I_{OP}/I_{MAX}$  current ratio is  $1.2 \text{ Amps}/3.0 \text{ Amps} = 0.40$ . The corresponding **M** factor can be determined from the graph shown in Figure C to be 3.2. Therefore the device's estimated resistance at 1.2 Amps can be calculated to be  $R = 3.2 \cdot 0.20 \text{ ohms} = 0.64 \text{ ohms}$ . If two different **SURGE-GARDs™** have similar  $I_{MAX}$  ratings but different

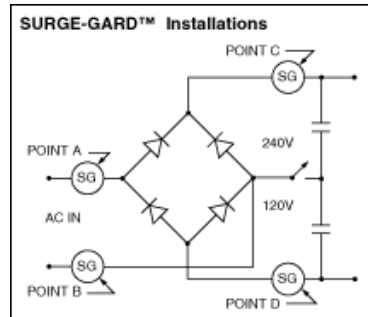

FIGURE A

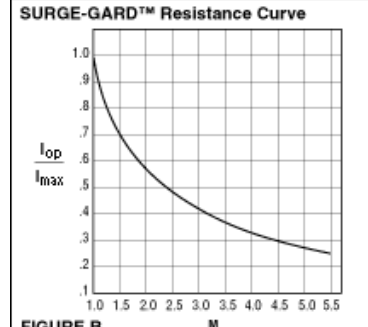

FIGURE B

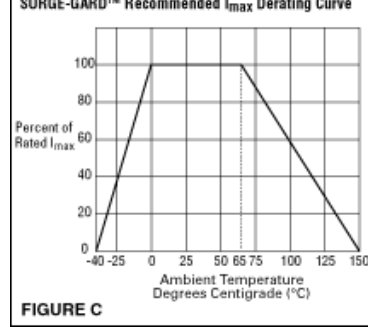
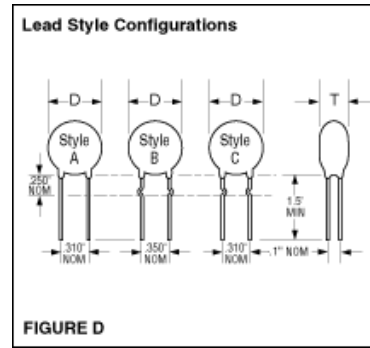

FIGURE C

R@25°C values and they meet the circuit requirements, then select the one with the lowest R<sub>IMAX</sub>nominal value.

- Lastly, if the MAX Operating Temp. range is >65°C or <0°C, refer to the SURGE-GARD™ Recommended I<sub>MAX</sub> De-rating Curve, Figure C.



**SURGE-GARD™ Specifications**

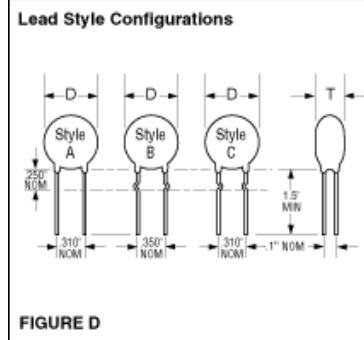
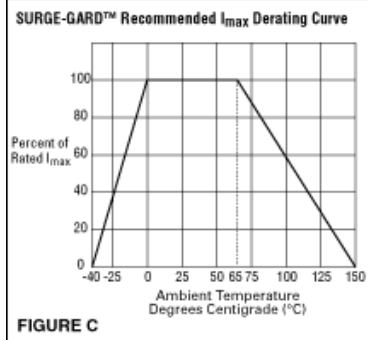
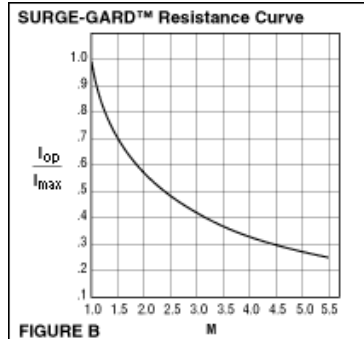
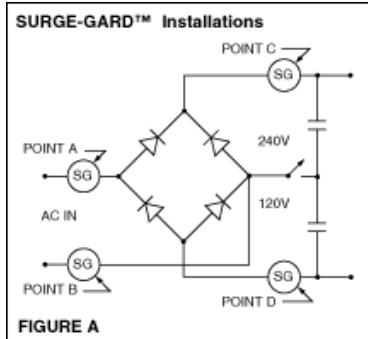

Style A	Style B	Style C	Part Number	R@25°C (Ohms)	R Tolerance (+%)	I <sub>max</sub> (AMPS)	R <sub>IMAX</sub> (Ohms)	Max. D (Inches)	Max. T (Inches)	Lead Dia. (Inches)	NTC Curve	Surge Rating (Joules)
SG260	SG326			0.5	20	30	0.010	1.250	0.200	0.040	A	31*
SG415	SG327			0.7	25	12	0.030	0.770	0.200	0.040	A	45
SG100	SG301			1.0	15	20	0.015	0.900	0.300	0.040	A	48*
SG405	SG328			1.0	25	30	0.015	1.250	0.250	0.040	A	157
SG416	SG329			1.3	25	8	0.050	0.550	0.200	0.040	A	40
SG110	SG302			2.0	15	18	0.030	0.900	0.350	0.040	A	80
SG420	SG355			2.0	25	23	0.025	1.250	0.300	0.040	A	250
SG120		SG303		2.5	15	3	0.150	0.600	0.250	0.032	A	27
SG130		SG304		2.5	15	7	0.050	0.600	0.250	0.032	A	27
SG140		SG305		2.5	15	9	0.040	0.600	0.250	0.032	A	27
SG150	SG306			2.5	15	10	0.040	0.900	0.300	0.040	A	87
SG160	SG307			2.5	15	15	0.030	0.900	0.300	0.040	A	87
SG170	SG308			4.0	15	8	0.070	0.600	0.250	0.040	A	27
SG32	SG330			4.0	20	14	0.050	0.900	0.350	0.040	A	100
SG180		SG309		5.0	15	2	0.400	0.600	0.250	0.032	A	36
SG413				5.0	25	2.8	0.250	0.530	0.200	0.025	A	23
SG190		SG310		5.0	15	4	0.150	0.600	0.250	0.032	A	36
SG450		SG373		5.0	15	6	0.100	0.600	0.250	0.032	A	30
SG200		SG311		5.0	15	7	0.070	0.600	0.250	0.032	A	40
SG44	SG332			5.0	20	8	0.050	0.600	0.250	0.040	A	40
SG26	SG333			5.0	15	12	0.060	0.900	0.275	0.040	A	100
SG418		SG334		6.0	15	5	0.150	0.600	0.270	0.032	A	40
SG210	SG312			7.0	15	4	0.200	0.600	0.300	0.040	A	50
SG85	SG335			7.0	25	5	0.150	0.600	0.300	0.040	A	45
SG64	SG336			7.0	15	10	0.080	0.950	0.275	0.040	J	100
SG13		SG337		10	15	2	0.300	0.500	0.250	0.032	A	17

SG220		SG313	10	15	3	0.200	0.450	0.300	0.032	A	17
SG42	SG338		10	15	5	0.200	0.600	0.350	0.040	A	44
SG27	SG314		10	15	6	0.150	0.500	0.350	0.040	A	40
SG40	SG72		10	20	8	0.100	0.900	0.350	0.040	J	50
SG451	SG374		12	15	4	0.220	0.500	0.350	0.040	A	40
SG452		SG375	15	15	2.5	0.330	0.550	0.300	0.032	A	40
SG86			16	25	1.7	0.600	0.530	0.300	0.025	A	45
SG414			16	25	2.7	0.400	0.530	0.300	0.025	A	45
SG63	SG320		16	25	4.0	0.250	0.750	0.250	0.040	J	50
SG230		SG315	20	15	1.75	0.600	0.500	0.300	0.032	A	31
SG411		SG341	25	25	1.7	0.600	0.500	0.300	0.032	A	30
SG412		SG342	25	25	2.4	0.400	0.500	0.300	0.032	A	30
SG38	SG343		30	15	3.0	0.400	0.600	0.250	0.040	B	25
SG240		SG316	40	15	2.0	0.600	0.625	0.250	0.032	B	20
SG52	SG344		47	25	3.0	0.500	0.770	0.240	0.040	B	55
SG453		SG376	60	15	1.5	1.000	0.600	0.250	0.032	B	50
SG250	SG317		120	15	3.0	0.900	0.925	0.250	0.040	C	36
SG31	SG346		220	20	1.3	1.900	0.600	0.300	0.040	C	25

For applications requiring ratings not shown, contact RTI Electronics, Inc. applications engineering.

Maximum operating voltage is 265V RMS.

\*Maximum operating voltage is 120V RMS

### NTC Resistance Temperature Conversion Tables

Temp °C	R-T Curve A		R-T Curve B		R-T Curve C		R-T Curve J	
	RT/R25	DEV	RT/R25	DEV	RT/R25	DEV	RT/R25	DEV
-60	43.0		75.0	6.6	140.5	6.6	52.5	
-55	31.9		54.1	6.1	96.4	6.1	39.0	
-50	24.3		39.7	5.6	67.0	5.6	29.2	18.5
-45	18.6		29.2	5.2	47.2	5.2	22.1	17.0
-40	14.4	7.6	21.7	4.7	33.7	4.7	16.9	15.4
-35	11.3	6.9	16.4	4.3	24.3	4.3	13.0	14.0
-30	8.93	6.2	12.5	3.8	17.7	3.8	10.1	12.5
-25	7.10	5.6	9.58	3.4	13.0	3.4	7.90	11.2
-20	5.69	5.0	7.42	3.0	9.71	3.0	6.24	9.9
-15	4.56	4.4	5.75	2.6	7.30	2.6	4.96	8.7
-10	3.68	3.7	4.50	2.2	5.53	2.2	3.97	7.4
-5	2.99	3.1	3.55	1.9	4.23	1.9	3.20	6.2
0	2.45	2.5	2.82	1.5	3.27	1.5	2.60	5.0
5	2.02	2.0	2.26	1.2	2.54	1.2	2.12	3.9
10	1.68	1.6	1.83	0.8	1.99	0.8	1.74	2.7
15	1.42	1.1	1.48	0.5	1.57	0.5	1.44	1.6
20	1.18	0.6	1.22	0.2	1.25	0.2	1.20	0.5
25	1.00	0.0	1.00	0.0	1.00	0.0	1.00	0.0
30	0.854	0.6	0.828	0.4	0.806	0.4	0.841	1.4
35	0.732	1.1	0.689	0.7	0.653	0.7	0.710	2.3
40	0.628	1.6	0.576	1.0	0.533	1.0	0.602	3.2
45	0.537	2.0	0.482	1.3	0.437	1.3	0.513	4.3
50	0.464	2.5	0.406	1.5	0.360	1.5	0.439	5.0
55	0.403	3.0	0.343	1.8	0.299	1.8	0.377	5.9
60	0.350	3.4	0.292	2.0	0.249	2.0	0.326	6.7
65	0.305	3.8	0.247	2.3	0.208	2.3	0.282	7.5
70	0.267	4.2	0.212	2.5	0.175	2.5	0.245	8.2
75	0.236	4.6	0.182	2.8	0.148	2.8	0.214	9.0
80	0.208	4.9	0.157	3.0	0.126	3.0	0.188	9.8
85	0.183	5.3	0.137	3.2	0.107	3.2	0.165	10.5
90	0.163	5.6	0.120	3.4	0.0916	3.4	0.146	11.2
95	0.145	6.0	0.105	3.6	0.0787	3.6	0.129	11.9
100	0.130	6.3	0.0920	3.8	0.0679	3.8	0.114	12.6
105	0.117	6.7	0.0812	4.0	0.0588	4.0	0.102	13.3
110	0.105	7.0	0.0723	4.2	0.0511	4.2	0.0908	13.9
115	0.0943	7.3	0.0641	4.4	0.0445	4.4	0.0813	14.4
120	0.0852	7.6	0.0569	4.6	0.0389	4.6	0.0730	14.9
125	0.0771	7.9	0.0508	4.8	0.0342	4.8	0.0657	15.6
130	0.0700	8.2	0.0455	4.9	0.0301	4.9	0.0593	16.3
135	0.0636	8.4	0.0408	5.1	0.0265	5.1	0.0536	17.0
140	0.0579	8.6	0.0368	5.3	0.0235	5.3	0.0486	17.6
145	0.0529	9.0	0.0332	5.4	0.0208	5.4	0.0442	18.0
150	0.0483	9.3	0.0300	5.5	0.0185	5.5	0.0402	18.4

### NTC Resistance Temperature Curve Characteristics

R-T Curve	A	B	C	J
Temp. Coeff $\alpha$ @ 25°C	-3.3%/°C	-3.9%/°C	-4.4%/°C	-3.5%/°C



## Looking for pricing, stock, or lifecycle information?

Click below to explore more details on WIN SOURCE:

 [View SG170 on WIN SOURCE](#)

 [Ametherm Information](#)

## Optimize Your Supply Chain with WIN SOURCE Solutions

-  Global Sourcing Solution
-  Obsolete Management
-  Cost Control Management
-  Shortage Management
-  Alternative Solution
-  Excess Inventory Management