



**THE DATASHEET OF
NB7V52MMNTXG**



1.8 V / 2.5 V Differential D Flip-Flop w/ Reset and CML Outputs

Multi-Level Inputs w/ Internal Termination

NB7V52M

Description

The NB7V52M is a 10 GHz differential D flip-flop with a differential asynchronous Reset. The differential D/ \bar{D} , CLK/ \bar{CLK} and R/ \bar{R} inputs incorporate dual internal 50 Ω termination resistors and will accept LVPECL, CML, LVDS logic levels.

When Clock transitions from logic Low to High, Data will be transferred to the differential CML outputs. The differential Clock inputs allow the NB7V52M to also be used as a negative edge triggered device.

The 16 mA differential CML outputs provide matching internal 50 Ω termination and produce 400 mV output swings when externally receiver terminated with a 50 Ω resistor to V_{CC} .

The NB7V52M is offered in a low profile 3 mm x 3 mm 16-pin QFN package. The NB7V52M is a member of the GigaComm™ family of high performance clock products. Application notes, models, and support documentation are available at www.onsemi.com.

Features

- Maximum Input Clock Frequency > 10 GHz
- Maximum Input Data Rate > 10 Gb/s
- Random Clock Jitter < 0.8 ps RMS, Max
- 200 ps Typical Propagation Delay
- 35 ps Typical Rise and Fall Times
- Differential CML Outputs, 400 mV Peak-to-Peak, Typical
- Operating Range: $V_{CC} = 1.71$ V to 2.625 V with $V_{EE} = 0$ V
- Internal 50 Ω Input Termination Resistors
- QFN-16 Package, 3mm x 3mm
- -40°C to +85°C Ambient Operating Temperature
- These are Pb-Free Devices



1
QFN-16
MN SUFFIX
CASE 485G

MARKING DIAGRAM*

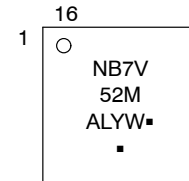

- A = Assembly Location
- L = Wafer Lot
- Y = Year
- W = Work Week
- = Pb-Free Package

(Note: Microdot may be in either location)
*For additional marking information, refer to Application Note [AND8002/D](#).

ORDERING INFORMATION

See detailed ordering and shipping information in the package dimensions section on page 9 of this data sheet.

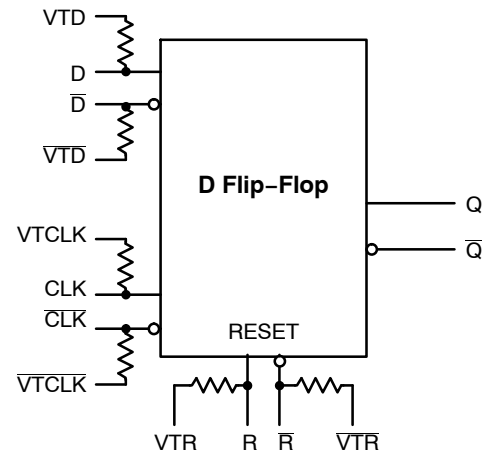

Figure 1. Logic Diagram

NB7V52M

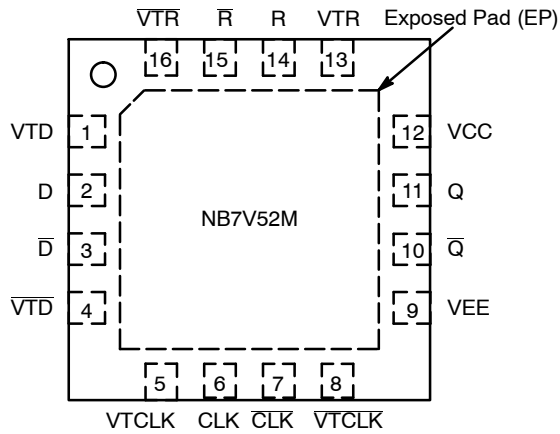

Figure 2. Pin Configuration (Top View)

Table 1. INPUT/OUTPUT SELECT TRUTH TABLE

R	D	CLK	Q
H	x	x	L
L	L	Z	L
L	H	Z	H

Z = LOW to HIGH Transition
x = Don't care

Table 1. Pin Description

Pin	Name	I/O	Description
1	VTD	-	Internal 50 Ω Termination Pin for D
2	D	LVPECL, CML, LVDS Input	Noninverted Differential Data Input. (Note 1)
3	\bar{D}	LVPECL, CML, LVDS Input	Inverted Differential Data Input. (Note 1)
4	\bar{VTD}	-	Internal 50 Ω Termination Pin for \bar{D}
5	VTCLK	-	Internal 50 Ω Termination Pin for CLK
6	CLK	LVPECL, CML, LVDS Input	Noninverted Differential Clock Input. (Note 1)
7	\bar{CLK}	LVPECL, CML, LVDS Input	Inverted Differential Clock Input. (Note 1)
8	\bar{VTCLK}	-	Internal 50 Ω Termination Pin for \bar{CLK}
9	VEE	-	Negative Supply Voltage. (Note 2)
10	\bar{Q}	CML Output	Inverted Differential Output
11	Q	CML Output	Noninverted Differential Output
12	VCC	-	Positive Supply Voltage. (Note 2)
13	VTR	-	Internal 50 Ω Termination Pin for R
14	R	LVPECL, CML, LVDS Input	Noninverted Asynchronous Differential Reset Input. (Note 1)
15	\bar{R}	LVPECL, CML, LVDS Input	Inverted Asynchronous Differential Reset Input. (Note 1)
16	\bar{VTR}	-	Internal 50 Ω Termination Pin for \bar{R}
-	EP	-	The Exposed Pad (EP) on the QFN-16 package bottom is thermally connected to the die for improved heat transfer out of package. The exposed pad must be attached to a heat-sinking conduit. The pad is electrically connected to the die, and must be electrically and thermally connected to VEE on the PC board.

1. In the differential configuration when the input termination pins (VT_x , \bar{VT}_x) are connected to a common termination voltage or left open, and if no signal is applied on CLK/ \bar{CLK} input, then the device will be susceptible to self-oscillation.
2. All VCC and VEE pins must be externally connected to a power supply for proper operation.

NB7V52M

Table 2. ATTRIBUTES

Characteristics		Value
ESD Protection	Human Body Model Machine Model	> 2 kV > 200 V
Moisture Sensitivity	16-QFN	Level 1
Flammability Rating	Oxygen Index: 28 to 34	UL 94 V-0 @ 0.125 in
Transistor Count		173
Meets or exceeds JEDEC Spec EIA/JESD78 IC Latchup Test		

For additional information, see Application Note AND8003/D.

Table 3. MAXIMUM RATINGS

Symbol	Parameter	Condition 1	Condition 2	Rating	Unit
V _{CC}	Positive Power Supply	V _{EE} = 0 V		3.0	V
V _{IO}	Positive Input/Output Voltage	V _{EE} = 0 V	-0.5 ≤ V _{IO} ≤ V _{CC} + 0.5	-0.5 to V _{CC} + 0.5	V
V _{INPP}	Differential Input Voltage CLK - $\overline{\text{CLK}}$, D - $\overline{\text{D}}$, R - $\overline{\text{R}}$			1.89	V
I _{OUT}	Output Current Through R _{TOUT} (50 Ω Resistor)	Continuous Surge		34 40	mA
I _{IN}	Input Current Through R _{TIN} (50 Ω Resistor)			± 40	mA
T _A	Operating Temperature Range			-40 to +85	°C
T _{stg}	Storage Temperature Range			-65 to +150	°C
θ _{JA}	Thermal Resistance (Junction-to-Ambient) (Note 3)	0 lfpm 500 lfpm	QFN-16 QFN-16	42 35	°C/W °C/W
θ _{JC}	Thermal Resistance (Junction-to-Case) (Note 3)		QFN-16	4	°C/W
T _{sol}	Wave Solder Pb-Free			265	°C

Stresses exceeding those listed in the Maximum Ratings table may damage the device. If any of these limits are exceeded, device functionality should not be assumed, damage may occur and reliability may be affected.

3. JEDEC standard multilayer board - 2S2P (2 signal, 2 power) with 8 filled thermal vias under exposed pad.

NB7V52M

Table 4. DC CHARACTERISTICS, Multi-Level Inputs $V_{CC} = 1.71\text{ V to }2.625\text{ V}$, $V_{EE} = 0\text{ V}$, $T_A = -40^\circ\text{C to }+85^\circ\text{C}$ (Note 4)

Symbol	Characteristic	Min	Typ	Max	Unit	
POWER SUPPLY CURRENT						
I_{CC}	Power Supply Current (Inputs and Outputs Open)	$V_{CC} = 2.5\text{ V}$ $V_{CC} = 1.8\text{ V}$	90 70	110 90	mA	
CML OUTPUTS						
V_{OH}	Output HIGH Voltage (Note 5)	$V_{CC} = 2.5\text{ V}$ $V_{CC} = 1.8\text{ V}$	$V_{CC} - 30$ 2470 1770	$V_{CC} - 10$ 2490 1790	V_{CC} 2500 1800	mV
V_{OL}	Output LOW Voltage (Note 5)	$V_{CC} = 2.5\text{ V}$	$V_{CC} - 650$ 1850	$V_{CC} - 500$ 2000	$V_{CC} - 400$ 2100	mV
		$V_{CC} = 1.8\text{ V}$	$V_{CC} - 600$ 1200	$V_{CC} - 450$ 1350	$V_{CC} - 350$ 1450	
DIFFERENTIAL CLOCK INPUTS DRIVEN SINGLE-ENDED (Note 6) (Figures 5 and 7)						
V_{th}	Input Threshold Reference Voltage Range (Note 7)	1000		$V_{CC} - 100$	mV	
V_{IH}	Single-Ended Input HIGH Voltage	$V_{th} + 100$		V_{CC}	mV	
V_{IL}	Single-Ended Input LOW Voltage	V_{EE}		$V_{th} - 100$	mV	
V_{ISE}	Single-Ended Input Voltage ($V_{IH} - V_{IL}$)	200		1200	mV	
DIFFERENTIAL D/D, CLK/CLK, R/R INPUTS DRIVEN DIFFERENTIALLY (Figures 6 and 8) (Note 8)						
V_{IHD}	Differential Input HIGH Voltage	1100		V_{CC}	mV	
V_{ILD}	Differential Input LOW Voltage	V_{EE}		$V_{CC} - 100$	mV	
V_{ID}	Differential Input Voltage ($V_{IHD} - V_{ILD}$)	100		1200	mV	
V_{CMR}	Input Common Mode Range (Differential Configuration, Note 9) (Figure 10)	1050		$V_{CC} - 50$	mV	
I_{IH}	Input HIGH Current (VT_x/VT_x Open)	-250		250	μA	
I_{IL}	Input LOW Current (VT_x/VT_x Open)	-250		250	μA	
TERMINATION RESISTORS						
R_{TIN}	Internal Input Termination Resistor	45	50	55	Ω	
R_{TOUT}	Internal Output Termination Resistor	45	50	55	Ω	

NOTE: Device will meet the specifications after thermal equilibrium has been established when mounted in a test socket or printed circuit board with maintained transverse airflow greater than 500 lfm.

- Input and output parameters vary 1:1 with V_{CC} .
- CML outputs loaded with $50\ \Omega$ to V_{CC} for proper operation.
- V_{th} , V_{IH} , V_{IL} , and V_{ISE} parameters must be complied with simultaneously.
- V_{th} is applied to the complementary input when operating in single-ended mode.
- V_{IHD} , V_{ILD} , V_{ID} and V_{CMR} parameters must be complied with simultaneously.
- V_{CMR} min varies 1:1 with V_{EE} , V_{CMR} max varies 1:1 with V_{CC} . The V_{CMR} range is referenced to the most positive side of the differential input signal.

NB7V52M

Table 5. AC CHARACTERISTICS $V_{CC} = 1.71\text{ V to }2.625\text{ V}$; $V_{EE} = 0\text{ V}$; $T_A = -40^\circ\text{C to }85^\circ\text{C}$ (Note 10)

Symbol	Characteristic	Min	Typ	Max	Unit	
f_{MAX}	Maximum Input Clock Frequency	10	12		GHz	
$f_{DATA\ MAX}$	Maximum Input Data Rate (PRBS23)	10	12		Gbps	
V_{OUTPP}	Output Voltage Amplitude (@ $V_{INPPmin}$) (See Figures 3 and 10, Note 11)	$f_{in} \leq 7\text{ GHz}$ 300 $f_{in} \leq 10\text{ GHz}$ 250	400 400		mV	
t_{PLH} , t_{PHL}	Propagation Delay to Differential Outputs, @ 1 GHz, Measured at Differential Cross-point	CLK/CLK to Q/Q R/R to Q/Q	200 300	350 600	ps	
t_S	Setup Time (D to CLK)	40	15		ps	
t_H	Hold Time (D to CLK)	50	20		ps	
t_{RR}	Reset Recovery	275	200		ps	
t_{PW}	Minimum Pulse Width	R/R	1		ns	
t_{JITTER}	RJ – Output Random Jitter (Note 12)	$f_{in} \leq 10\text{ GHz}$	0.2	0.8	ps RMS	
V_{INPP}	Input Voltage Swing (Differential Configuration) (Note 13)	100		1200	mV	
t_r , t_f	Output Rise/Fall Times @ 1 GHz (20% – 80%),	Q, Q	20	35	50	ps

NOTE: Device will meet the specifications after thermal equilibrium has been established when mounted in a test socket or printed circuit board with maintained transverse airflow greater than 500 lfm.

10. Measured using a 400 mV V_{INPP} source, 50% duty cycle clock source. All output loading with external $50\ \Omega$ to V_{CC} . Input edge rates $\geq 40\text{ ps}$ (20% – 80%).

11. Output voltage swing is a single-ended measurement operating in differential mode.

12. Additive RMS jitter with 50% duty cycle clock signal.

13. Input voltage swing is a single-ended measurement operating in differential mode.

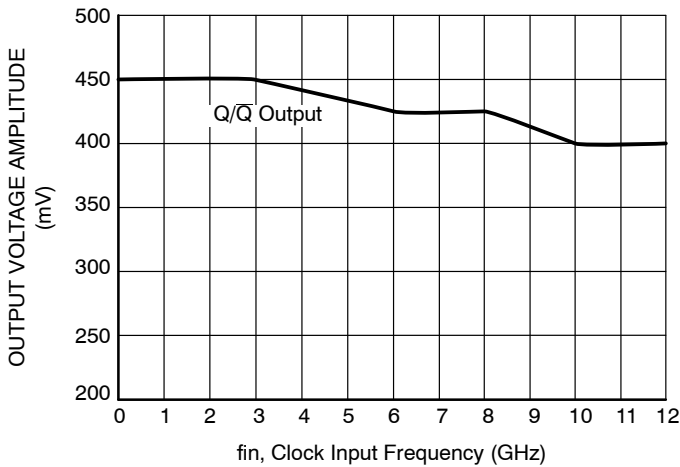

Figure 3. Clock Output Voltage Amplitude (V_{OUTPP}) vs. Input Frequency (f_{in}) at Ambient Temperature (Typ)

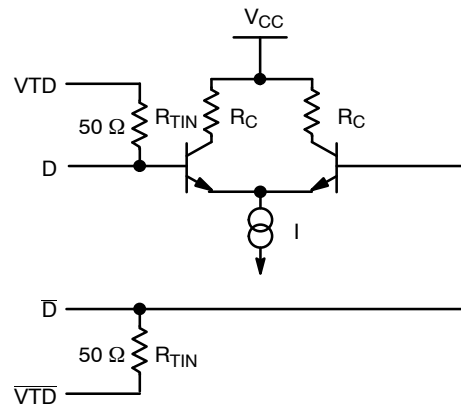

Figure 4. Simplified Input Structure

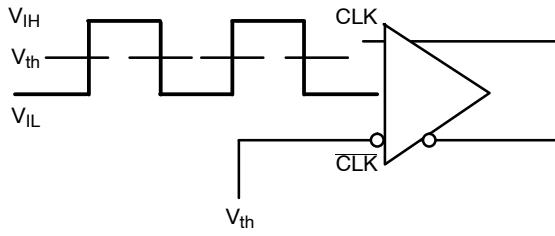

Figure 5. Differential Input Driven Single-Ended

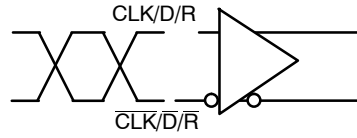

Figure 6. Differential Inputs Driven Differentially

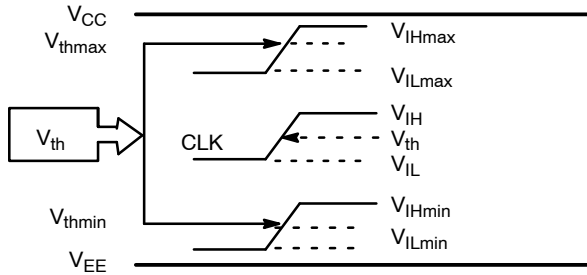

Figure 7. V_{th} Diagram

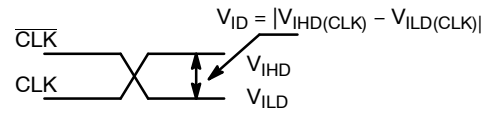

Figure 8. Differential Inputs Driven Differentially

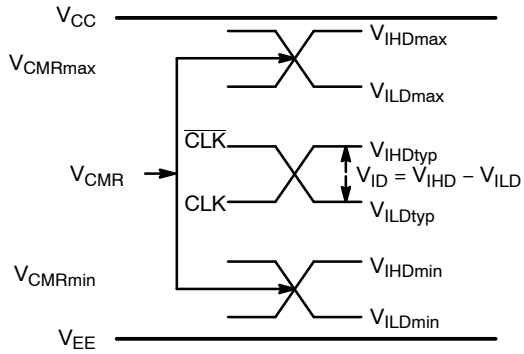

Figure 9. V_{CMR} Diagram

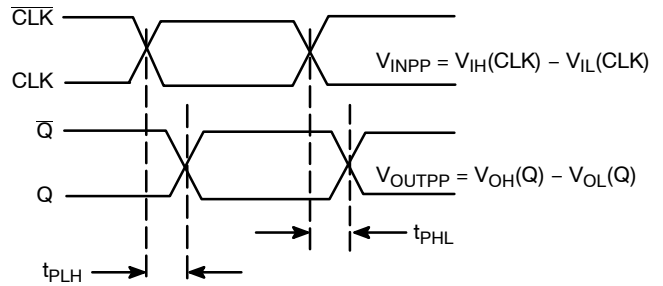

Figure 10. AC Reference Measurement

NB7V52M

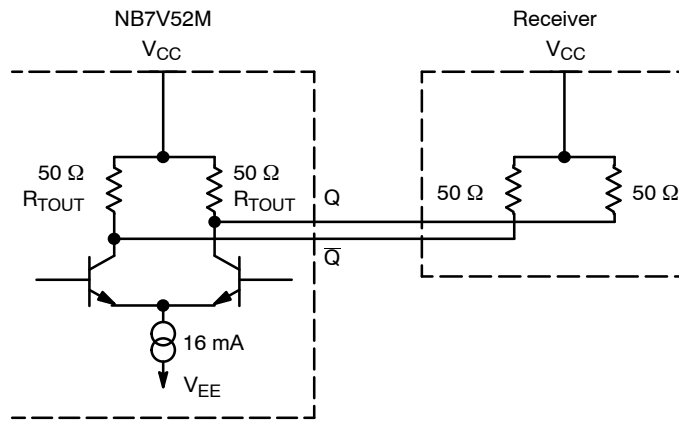

Figure 11. Typical CML Output Structure and Termination

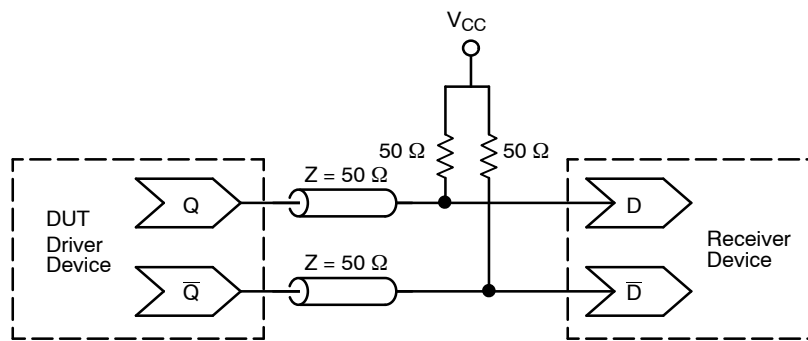

Figure 12. Typical Termination for CML Output Driver and Device Evaluation

NB7V52M

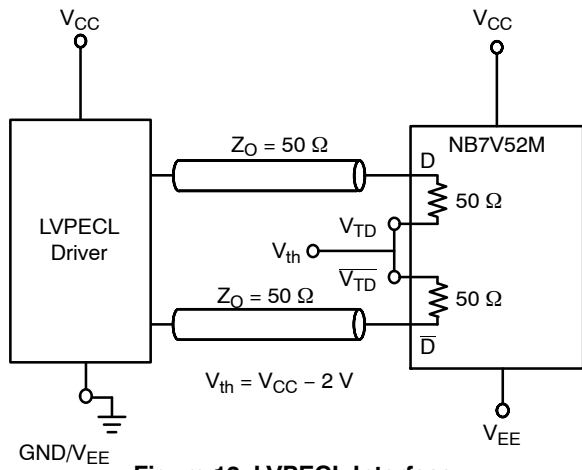

Figure 13. LVPECL Interface

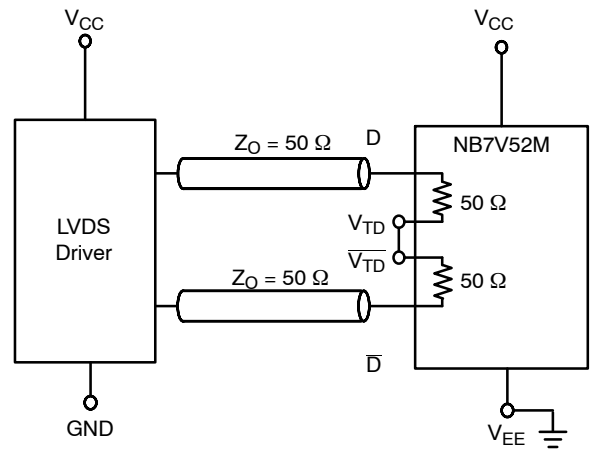

Figure 14. LVDS Interface

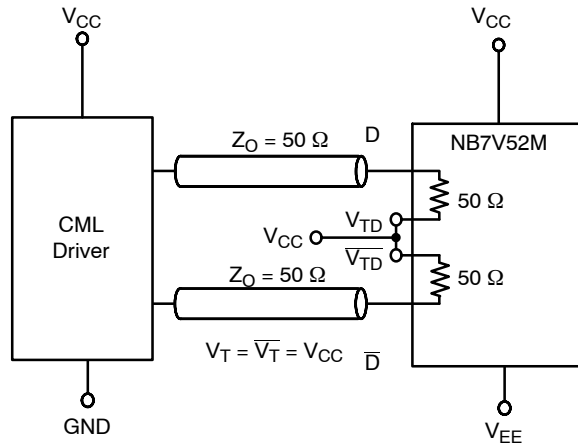

Figure 15. Standard 50 Ω Load CML Interface

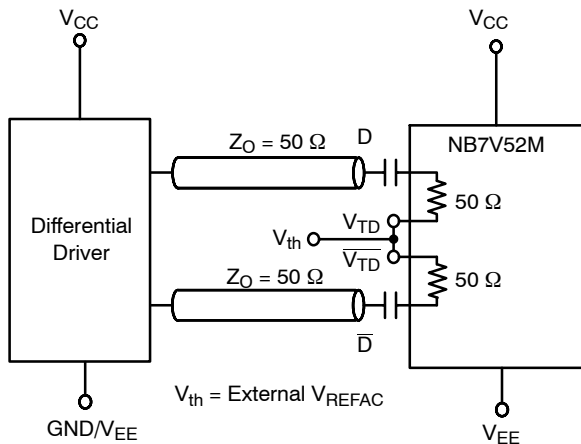

Figure 16. Capacitor-Coupled Differential Interface ($V_T/\overline{V_T}$ Connected to External V_{REFAC} ; V_{REFAC} Bypassed to Ground with 0.1 μF Capacitor)

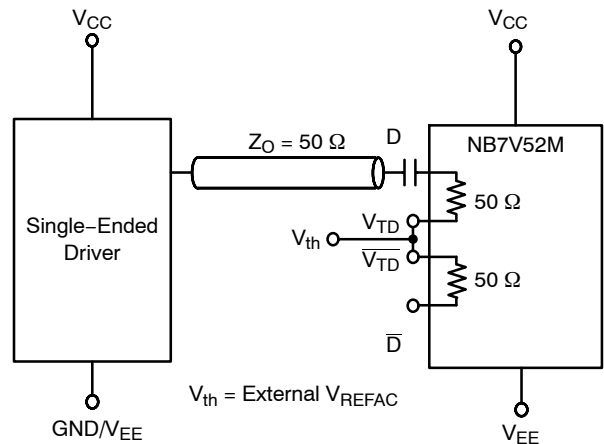

Figure 17. Capacitor-Coupled Single-Ended Interface ($V_T/\overline{V_T}$ Connected to External V_{REFAC} ; V_{REFAC} Bypassed to Ground with 0.1 μF Capacitor)

NB7V52M

ORDERING INFORMATION

Device	Package	Shipping†
NB7V52MMNG	QFN-16 (Pb-free)	123 Units / Rail
NB7V52MMNHTBG	QFN-16 (Pb-free)	100 / Tape & Reel
NB7V52MMNTXG	QFN-16 (Pb-free)	3000 / Tape & Reel

†For information on tape and reel specifications, including part orientation and tape sizes, please refer to our Tape and Reel Packaging Specifications Brochure, [BRD8011/D](#).

GigaComm is a trademark of Semiconductor Components Industries, LLC dba "onsemi" or its affiliates and/or subsidiaries in the United States and/or other countries.



1
SCALE 2:1

QFN16 3x3, 0.5P
CASE 485G
ISSUE G

DATE 08 OCT 2021

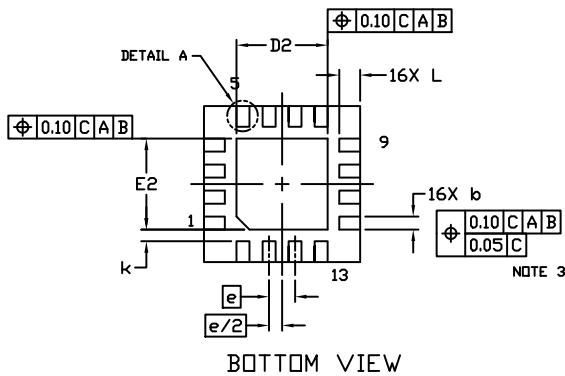
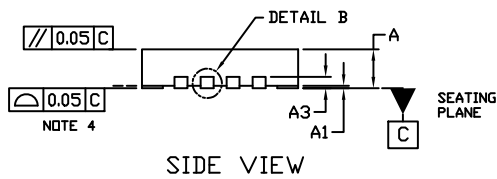
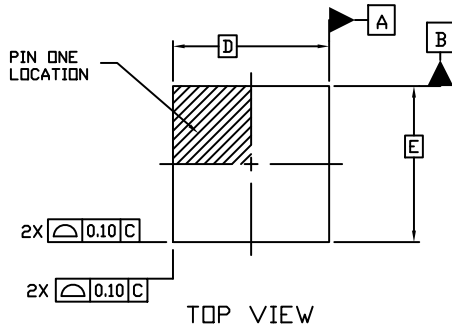

NOTES:

1. DIMENSIONING AND TOLERANCING PER ASME Y14.5M, 1994.
2. CONTROLLING DIMENSION: MILLIMETERS
3. DIMENSION b APPLIES TO PLATED TERMINAL AND IS MEASURED BETWEEN 0.15 AND 0.30 MM FROM THE TERMINAL TIP.
4. COPLANARITY APPLIES TO THE EXPOSED PAD AS WELL AS THE TERMINALS.

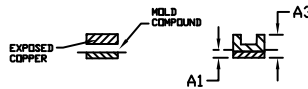

DETAIL B
ALTERNATE
CONSTRUCTIONS

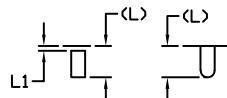

DETAIL A
ALTERNATE TERMINAL
CONSTRUCTIONS

DIM	MILLIMETERS		
	MIN.	NDM.	MAX.
A	0.80	0.90	1.00
A1	0.00	0.03	0.05
A3	0.20 REF		
b	0.18	0.24	0.30
D	3.00 BSC		
D2	1.65	1.75	1.85
E	3.00 BSC		
E2	1.65	1.75	1.85
e	0.50 BSC		
k	0.18 TYP		
L	0.30	0.40	0.50
L1	0.00	0.08	0.15

MOUNTING FOOTPRINT

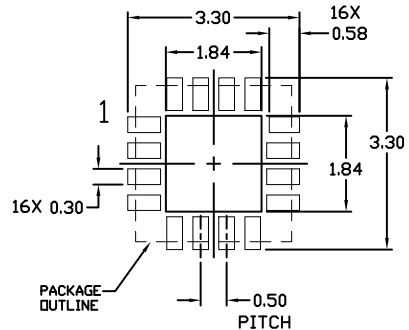

GENERIC MARKING DIAGRAM*

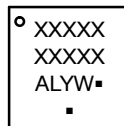

- XXXXX = Specific Device Code
- A = Assembly Location
- L = Wafer Lot
- Y = Year
- W = Work Week
- = Pb-Free Package

(Note: Microdot may be in either location)

*This information is generic. Please refer to device data sheet for actual part marking. Pb-Free indicator, "G" or microdot "▪", may or may not be present. Some products may not follow the Generic Marking.

DOCUMENT NUMBER:	98AON04795D	Electronic versions are uncontrolled except when accessed directly from the Document Repository. Printed versions are uncontrolled except when stamped "CONTROLLED COPY" in red.
DESCRIPTION:	QFN16 3X3, 0.5P	PAGE 1 OF 1

onsemi and onsemi are trademarks of Semiconductor Components Industries, LLC dba onsemi or its subsidiaries in the United States and/or other countries. onsemi reserves the right to make changes without further notice to any products herein. onsemi makes no warranty, representation or guarantee regarding the suitability of its products for any particular purpose, nor does onsemi assume any liability arising out of the application or use of any product or circuit, and specifically disclaims any and all liability, including without limitation special, consequential or incidental damages. onsemi does not convey any license under its patent rights nor the rights of others.

onsemi, **Onsemi**, and other names, marks, and brands are registered and/or common law trademarks of Semiconductor Components Industries, LLC dba "**onsemi**" or its affiliates and/or subsidiaries in the United States and/or other countries. **onsemi** owns the rights to a number of patents, trademarks, copyrights, trade secrets, and other intellectual property. A listing of **onsemi**'s product/patent coverage may be accessed at www.onsemi.com/site/pdf/Patent-Marking.pdf. **onsemi** reserves the right to make changes at any time to any products or information herein, without notice. The information herein is provided "as-is" and **onsemi** makes no warranty, representation or guarantee regarding the accuracy of the information, product features, availability, functionality, or suitability of its products for any particular purpose, nor does **onsemi** assume any liability arising out of the application or use of any product or circuit, and specifically disclaims any and all liability, including without limitation special, consequential or incidental damages. Buyer is responsible for its products and applications using **onsemi** products, including compliance with all laws, regulations and safety requirements or standards, regardless of any support or applications information provided by **onsemi**. "Typical" parameters which may be provided in **onsemi** data sheets and/or specifications can and do vary in different applications and actual performance may vary over time. All operating parameters, including "Typicals" must be validated for each customer application by customer's technical experts. **onsemi** does not convey any license under any of its intellectual property rights nor the rights of others. **onsemi** products are not designed, intended, or authorized for use as a critical component in life support systems or any FDA Class 3 medical devices or medical devices with a same or similar classification in a foreign jurisdiction or any devices intended for implantation in the human body. Should Buyer purchase or use **onsemi** products for any such unintended or unauthorized application, Buyer shall indemnify and hold **onsemi** and its officers, employees, subsidiaries, affiliates, and distributors harmless against all claims, costs, damages, and expenses, and reasonable attorney fees arising out of, directly or indirectly, any claim of personal injury or death associated with such unintended or unauthorized use, even if such claim alleges that **onsemi** was negligent regarding the design or manufacture of the part. **onsemi** is an Equal Opportunity/Affirmative Action Employer. This literature is subject to all applicable copyright laws and is not for resale in any manner.

ADDITIONAL INFORMATION

TECHNICAL PUBLICATIONS:



Technical Library: www.onsemi.com/design/resources/technical-documentation
onsemi Website: www.onsemi.com

ONLINE SUPPORT: www.onsemi.com/support

For additional information, please contact your local Sales Representative at www.onsemi.com/support/sales

Looking for pricing, stock, or lifecycle information?

Click below to explore more details on WIN SOURCE:

-  [View NB7V52MMNTXG on WIN SOURCE](#)
-  [ON Semiconductor Information](#)

Optimize Your Supply Chain with WIN SOURCE Solutions

-  Global Sourcing Solution
-  Obsolete Management
-  Cost Control Management
-  Shortage Management
-  Alternative Solution
-  Excess Inventory Management