



**THE DATASHEET OF  
PHE845VY6220MR30L2**



## Overview

The PHE845 series is constructed of metallized polypropylene film encapsulated with self-extinguishing resin in a box of material that meets the requirements of UL 94 V-0.

## Applications

For use as an electromagnetic interference (EMI) suppression filter in across-the-line applications that require X1 safety classification. Suitable for use in situations in which capacitor failure does not pose a danger of electric shock.

## Benefits

- Approvals: ENEC, UL, cUL
- Class X1 (IEC 60384-14)
- THB Grade IA: 40°C, 93% RH, 500 hours at 760 V URAC acc. to IEC 60384-14
- Rated voltage: 760 VAC 50/60 Hz
- Capacitance range: 0.01 – 1.0 µF
- Lead spacing: 22.5 – 37.5 mm
- Capacitance tolerance: ±20%, ±10%
- Climatic category 40/105/56/B, IEC 60068-1
- Tape & Reel in accordance with IEC 60286-2
- RoHS compliant and lead-free terminations
- Operating temperature range of -40°C to +105°C
- 100% screening factory test at 4,250 VDC
- Self-healing properties

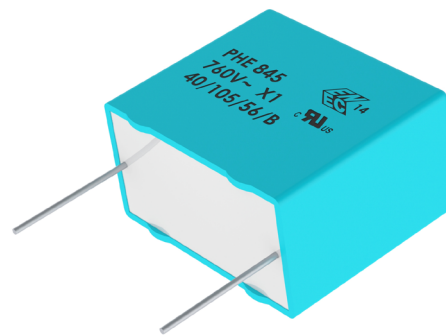

## Customer Part Number

PHE845	V	D	5100	M	R06L2
Series	Rated Voltage (VAC)	Lead Spacing (mm)	Capacitance Code (pF)	Capacitance Tolerance	Packaging
X1, Metallized Polypropylene	V = 760	D = 22.5 F = 27.5 R = 37.5	The last three digits represent significant figures. The first digit specifies the total number of digits.	K = ±10% M = ±20%	See Ordering Options Table

## KEMET Internal Part Number

F	845	D	D	103	M	760	C
Capacitor Class	Series	Lead Spacing (mm)	Size Code	Capacitance Code (pF)	Capacitance Tolerance	Rated Voltage (VAC)	Packaging
F = Film	X1, Metallized Polypropylene	D = 22.5 F = 27.5 R = 37.5	See Dimension Table	First two digits represent significant figures. Third digit specifies number of zeros.	K = ±10% M = ±20%	760 = 760	See Ordering Options Table

**Metallized Polypropylene Film EMI Suppression Capacitors**  
**PHE845, Class X1, 760 VAC, 105°C**

**Ordering Options Table**

Lead Spacing Nominal (mm)	Type of Leads and Packaging	Lead Length (mm)	KEMET Lead and Packaging Code	Legacy Lead and Packaging Code
22.5	<b>Standard Lead and Packaging Options</b>			
	Bulk (Tray)–Short Leads	6 +0/-1	C	R06L2 <sup>(1)</sup>
	<b>Other Lead and Packaging Options</b>			
	Pizza Pack	6 +0/-1	Z	R06L2 <sup>(1)</sup>
	Bulk (Tray)–Long Leads	30 +5/-0	ALW0L	R30L2
	Tape & Reel (Standard Reel)	H <sub>0</sub> = 18.5 ±0.5	L	R17T0
	Tape & Reel (Large Reel)	H <sub>0</sub> = 18.5 ±0.5	P	R17T1
27.5	<b>Standard Lead and Packaging Options</b>			
	Bulk (Tray)–Short Leads	6 +0/-1	C	R06L2 <sup>(1)</sup>
	<b>Other Lead and Packaging Options</b>			
	Pizza Pack	6 +0/-1	Z	R06L2 <sup>(1)</sup>
	Bulk (Tray)–Long Leads	30 +5/-0	ALW0L	R30L2
	Tape & Reel (Large Reel)	H <sub>0</sub> = 18.5 ±0.5	P	R17T1
37.5	<b>Standard Lead and Packaging Options</b>			
	Bulk (Tray)–Short Leads	6 +0/-1	C	R06L2 <sup>(1)</sup>
	<b>Other Lead and Packaging Options</b>			
	Pizza Pack	6 +0/-1	Z	R06L2 <sup>(1)</sup>

*(1) Please specify Bulk (Tray) or Pizza Packaging*

## Dimensions – Millimeters

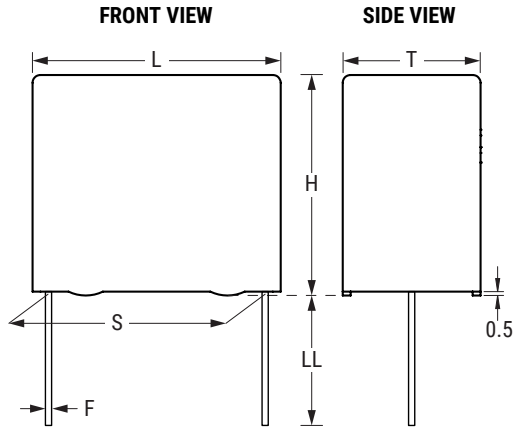

KEMET Size Code	Legacy Size Code	S		T		H		L		F	
		Nominal	Tolerance	Nominal	Tolerance	Nominal	Tolerance	Nominal	Tolerance	Nominal	Tolerance
DD	D13	22.5	±0.4	6.5	Maximum	14.5	Maximum	26.0	Maximum	0.8	±0.05
DG	D17	22.5	±0.4	7.0	Maximum	16.5	Maximum	26.0	Maximum	0.8	±0.05
DM	D15	22.5	±0.4	9.0	Maximum	18.5	Maximum	26.0	Maximum	0.8	±0.05
DR	D18	22.5	±0.4	10.5	Maximum	19.0	Maximum	26.0	Maximum	0.8	±0.05
DT	D16	22.5	±0.4	11.0	Maximum	21.5	Maximum	26.0	Maximum	0.8	±0.05
DW	D20	22.5	±0.4	13.5	Maximum	23.0	Maximum	26.0	Maximum	0.8	±0.05
DY	D19	22.5	±0.4	15.5	Maximum	24.5	Maximum	26.0	Maximum	0.8	±0.05
FE	F11	27.5	±0.4	10.5	Maximum	20.5	Maximum	31.5	Maximum	0.8	±0.05
FG	F12	27.5	±0.4	11.5	Maximum	22.5	Maximum	31.5	Maximum	0.8	±0.05
FK	F03	27.5	±0.4	13.5	Maximum	23.0	Maximum	31.5	Maximum	0.8	±0.05
FS	F15	27.5	±0.4	19.0	Maximum	29.0	Maximum	31.5	Maximum	0.8	±0.05
FV	F16	27.5	±0.4	21.0	Maximum	30.0	Maximum	31.5	Maximum	0.8	±0.05
RH	R04	37.5	±0.5	15.0	Maximum	26.0	Maximum	41.0	Maximum	1.0	±0.05
RK	R02	37.5	±0.5	16.5	Maximum	32.0	Maximum	41.0	Maximum	1.0	±0.05
RM	R03	37.5	±0.5	19.0	Maximum	36.0	Maximum	41.0	Maximum	1.0	±0.05
RP	R06	37.5	±0.5	21.0	Maximum	38.0	Maximum	41.0	Maximum	1.0	±0.05

Note: See the Ordering Options Table for lead length (LL) options.

# Metallized Polypropylene Film EMI Suppression Capacitors

## PHE845, Class X1, 760 VAC, 105°C



### Performance Characteristics

Dielectric	Polypropylene film		
Plates	Metal layer deposited by evaporation under vacuum		
Winding	Non-inductive type. Triple design.		
Leads	Tinned wire		
Protection	Plastic case, thermosetting resin-filled. Box material is solvent-resistant and flame-retardant according to UL94 V-0.		
Rated Voltage ( $V_R$ )	760 VAC 50/60 Hz		
Capacitance Range	0.010 – 1.0 $\mu$ F		
Capacitance Values	E6 series (IEC 60063)		
Capacitance Tolerance	$\pm$ 20% standard, $\pm$ 10% option		
Operating Temperature Range	-40°C to 105°C		
Rated Temperature	105°C		
Climatic Category	40/105/56/B IEC 60068-1		
Approvals	ENEC, UL, cUL		
Related Documents	EN/IEC 60384-14:2005, UL 60384-14, CAN/CSA E60384-14:09		
Dissipation Factor ( $\tan\delta$ )	Maximum Values at +23°C		
	Frequency	$C \leq 0.1 \mu\text{F}$	$0.1 \mu\text{F} < C \leq 1 \mu\text{F}$
	1 kHz	0.1%	0.1%
	10 kHz	0.2%	0.4%
	100 kHz	0.6%	-
Test Voltage Between Terminals	The 100% screening factory test is carried out at 4,250 VDC. The voltage level is selected to meet the requirements in applicable equipment standards. All electrical characteristics are checked after the test. It is not permitted to repeat this test as there is a risk to damage the capacitor. KEMET is not liable in such case for any failures.		
Resonance Frequency	Tabulated self-resonance frequencies $f_0$ (see Table 1 – Ratings & Part Number Reference)		
Insulation Resistance	Measured at +25°C $\pm$ 5°C, according to IEC 60384-2		
	Minimum Values Between Terminals		
	$C \leq 0.33 \mu\text{F}$	$C > 0.33 \mu\text{F}$	
	$\geq 30,000 \text{ M}\Omega$	$\geq 10,000 \text{ M}\Omega \cdot \mu\text{F}$	
In DC Applications	Recommended voltage $\leq 1,500$ VDC		

## Environmental Test Data

Test	IEC Publication	Procedure
Endurance	IEC 60384-14:2005	1.25 x V <sub>R</sub> VAC 50 Hz, once every hour increase to 1,000 VAC for 0.1 second, 1,000 hours at upper rated temperature
Vibration	IEC 60068-2-6 Test Fc	3 directions at 2 hours each 10 – 55 Hz at 0.75 mm or 98 m/s <sup>2</sup> No visible damage. No open or short circuit.
Bump	IEC 60068-2-29 Test Eb	1,000 bumps at 390 m/s <sup>2</sup> No visible damage. No open or short circuit.
Change of Temperature	IEC 60068-2-14 Test Na	Upper and lower rated temperature 5 cycles No visible damage.
Active Flammability	IEC 60384-14:2005	V <sub>R</sub> + 20 surge pulses at 4 kV (pulse every 5 seconds)
Passive Flammability	IEC 60384-14:2005	IEC 60384-1, IEC 60695-11-5 Needle Flame Test
Damp Heat Steady State	IEC 60068-2-78 Test Cab	+40°C and 90 – 95% RH, 56 days
THB Test	According to Grade IA	+40°C and 90 - 95% RH, 21 days at rated AC-voltage Capacitance change ( $\Delta C/C$ ): $\leq 10\%$ Dissipation factor change ( $\Delta \tan \delta$ ): $\leq 24 * 10^{-3}$ (at 10 kHz) for C $\leq 1 \mu F$ Dissipation factor change ( $\Delta \tan \delta$ ): $\leq 15 * 10^{-3}$ (at 1 kHz) for C $> 1 \mu F$ Insulation resistance IR in seconds or time constant $\tau = CR$ Rins: $\geq 50\%$ of initial limit

## Approvals

Certification Body	Mark	Specification	File Number
IMQ S.p.A.		EN/IEC 60384-14	CA08.00256
UL		UL 60384 and CAN/CSA E60384-14 (760 VAC)	E73869

## Environmental Compliance

All KEMET EMI capacitors are RoHS compliant.



**Metallized Polypropylene Film EMI Suppression Capacitors**  
**PHE845, Class X1, 760 VAC, 105°C**

**Table 1 – Ratings & Part Number Reference**

Capacitance Value (µF)	Size Code (KEMET/Legacy)	Maximum Dimensions in mm			Lead Spacing (S)	f <sub>o</sub> (MHz)	dV/dt (V/µs)	KEMET Part Number	Legacy Part Number
		T	H	L					
0.010	DD/D13	6.5	14.5	26.0	22.5	11	100	F845DD103(1)760(2)	PHE845VD5100(1)(2)
0.015	DD/D13	6.5	14.5	26.0	22.5	9.2	100	F845DD153(1)760(2)	PHE845VD5150(1)(2)
0.022	DD/D13	6.5	14.5	26.0	22.5	7.6	100	F845DD223(1)760(2)	PHE845VD5220(1)(2)
0.033	DF/D17	7.0	16.5	26.0	22.5	6.4	100	F845DF333(1)760(2)	PHE845VD5330(1)(2)
0.047	DM/D15	9.0	18.5	26.0	22.5	5.3	100	F845DM473(1)760(2)	PHE845VD5470(1)(2)
0.068	DR/D18	10.5	19.0	26.0	22.5	4.4	100	F845DR683(1)760(2)	PHE845VD5680(1)(2)
0.10	DT/D16	11.0	21.5	26.0	22.5	3.5	100	F845DT104(1)760(2)	PHE845VD6100(1)(2)
0.15	DW/D20	13.5	23.0	26.0	22.5	3.1	100	F845DW154(1)760(2)	PHE845VD6150(1)(2)
0.22	DY/D19	15.5	24.5	26.0	22.5	2.7	100	F845DY224M760(2)	PHE845VY6220M(2)
0.10	FE/F11	10.5	20.5	31.5	27.5	3.4	100	F845FE104(1)760(2)	PHE845VF6100(1)(2)
0.15	FG/F12	11.5	22.5	31.5	27.5	3.0	100	F845FG154(1)760(2)	PHE845VF6150(1)(2)
0.22	FK/F03	13.5	23.0	31.5	27.5	2.4	100	F845FK224(1)760(2)	PHE845VF6220(1)(2)
0.33	FS/F15	19.0	29.0	31.5	27.5	2.0	100	F845FS334(1)760(2)	PHE845VF6330(1)(2)
0.47	FV/F16	21.0	30.0	31.5	27.5	1.6	100	F845FV474M760(2)	PHE845VZ6470M(2)
0.47	RH/R04	15.0	26.0	41.0	37.5	1.6	100	F845RH474M760(2)	PHE845VW6470M(2)
0.47	RK/R02	16.5	32.0	41.0	37.5	1.6	100	F845RK474(1)760(2)	PHE845VR6470(1)(2)
0.68	RM/R03	19.0	36.0	41.0	37.5	1.2	100	F845RM684(1)760(2)	PHE845VR6680(1)(2)
1.0	RP/R06	21.0	38.0	41.0	37.5	1.0	100	F845RP105M760(2)	PHE845VW7100M(2)
Capacitance Value (µF)	Size Code (KEMET/Legacy)	T (mm)	H (mm)	L (mm)	Lead Spacing (S)	f <sub>o</sub> (MHz)	dV/dt (V/µs)	KEMET Part Number	Legacy Part Number

(1) M = ±20%, K = ±10%.

(2) Insert ordering code for lead type and packaging. See the Ordering Options Table for available options.

## Soldering Process

The implementation of the RoHS directive has resulted in the selection of SnAuCu (SAC) alloys or SnCu alloys as primary solder. This implementation has increased the liquidus temperature from 183°C for SnPb eutectic alloys to 217 – 221°C for the new alloys. As a result, the heat stress to the components, even in wave soldering, has increased considerably due to higher pre-heat and wave temperatures. Polypropylene capacitors are especially sensitive to heat (the melting point of polypropylene is 160 – 170°C). Wave soldering can be destructive, especially for mechanically small polypropylene capacitors (with lead spacing of 5 – 15 mm), and great care must be taken during soldering. The recommended solder profiles from KEMET should be used. Consult KEMET with any questions. In general, the wave soldering curve from IEC Publication 61760-1 Edition 2 serves as a solid guideline for successful soldering. See Figure 1.

Reflow soldering is not recommended for through-hole film capacitors. Exposing capacitors to a soldering profile in excess of the recommended limits may result in degradation of or permanent damage to the capacitors.

Do not place the polypropylene capacitor through an adhesive curing oven to cure resin for surface-mount components. Insert through-hole parts after curing the surface mount parts. Consult KEMET to discuss the actual temperature profile in the oven, if through-hole components must pass through the adhesive curing process. A maximum of two soldering cycles is recommended. Allow time for the capacitor surface temperature to return to normal before the second soldering cycle.

### Manual Soldering Recommendations

Following is the recommendation for manual soldering with a soldering iron.

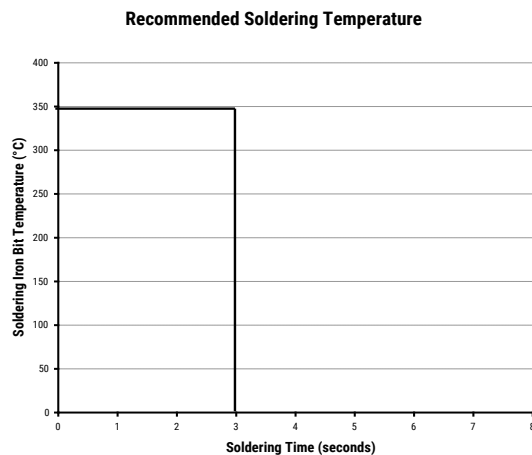

Soldering iron tip temperature should be set at 350°C (+10°C maximum), with the soldering duration not to exceed 3 seconds.

### Wave Soldering Recommendations

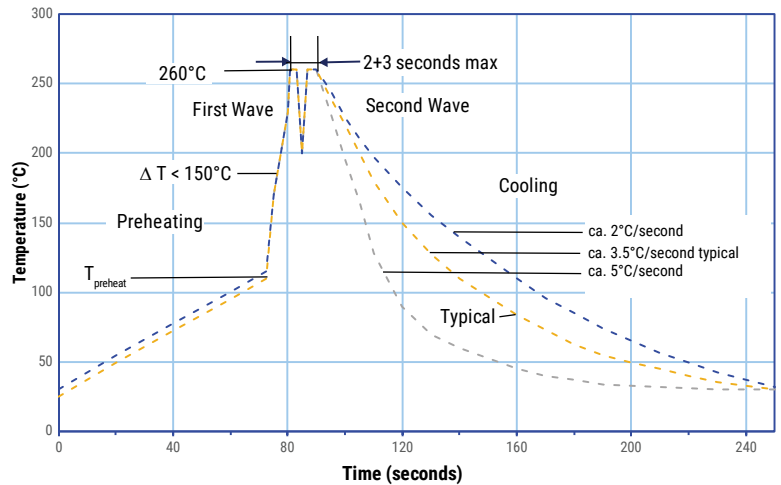

## Soldering Process cont.

### Wave Soldering Recommendations cont.

1. The table indicates the maximum set-up temperature of the soldering process.

Figure 1

Dielectric film material	Maximum Preheat Temperature		Maximum Peak Soldering Temperature	
	Capacitor Pitch $\geq$ 10 mm	Capacitor Pitch $>$ 15 mm	Capacitor Pitch $\leq$ 15 mm	Capacitor Pitch $>$ 15 mm
Polyester	130°C	130°C	270°C	270°C
Polypropylene	110°C	130°C	260°C	270°C
Paper	130°C	140°C	270°C	270°C
Polyphenylene Sulphide	150°C	160°C	270°C	270°C

2. The maximum temperature measured inside the capacitor: set the temperature so that the maximum temperature is below the limit inside the element.

Dielectric Film Material	Maximum Temperature Measured Inside the Element
Polyester	160°C
Polypropylene	110°C
Paper	160°C
Polyphenylene Sulphide	160°C

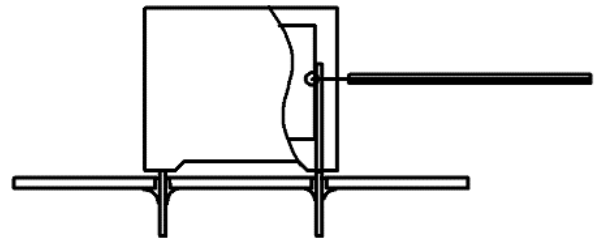

Temperature monitored inside the capacitor.

### Selective Soldering Recommendations

Selective dip soldering is a variation of reflow soldering. In this method, the printed circuit board with through-hole components to be soldered is preheated and transported over the solder bath, as in normal flow soldering, without touching the solder. When the board is over the bath, it is stopped. Pre-designed solder pots are lifted from the bath with molten solder only at the places of the selected components, and then pressed against the lower surface of the board to solder the components.

The temperature profile for selective soldering is similar to the double-wave flow soldering outlined in this document. **However, instead of two baths, there is only one with a time from 3 to 10 seconds.** In selective soldering, the risk of overheating is greater than in double-wave flow soldering. Great care must be taken so that the parts do not overheat.

# Metallized Polypropylene Film EMI Suppression Capacitors

PHE845, Class X1, 760 VAC, 105°C

## Construction

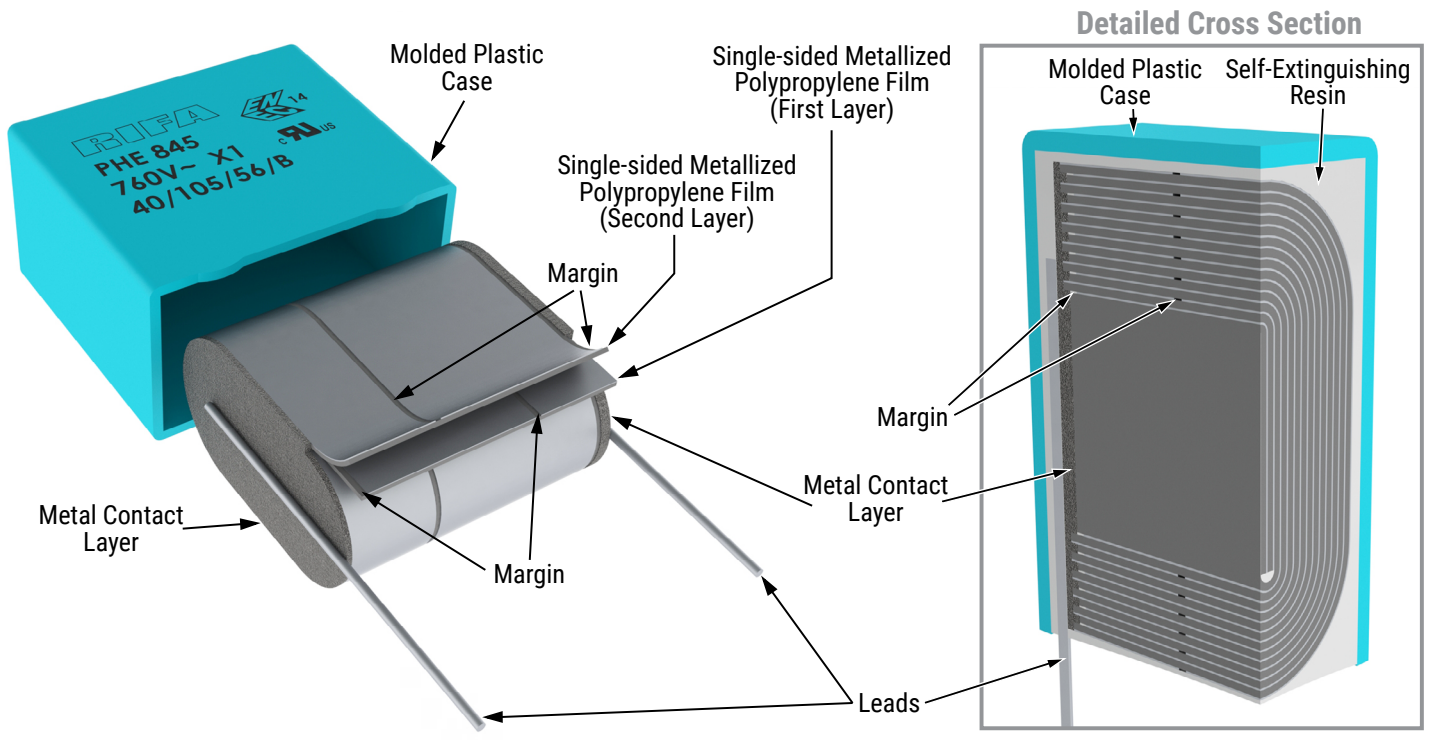

## Winding Scheme

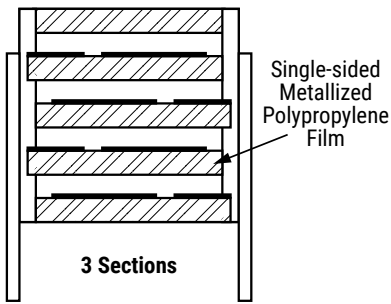

# Metallized Polypropylene Film EMI Suppression Capacitors

## PHE845, Class X1, 760 VAC, 105°C

### Marking

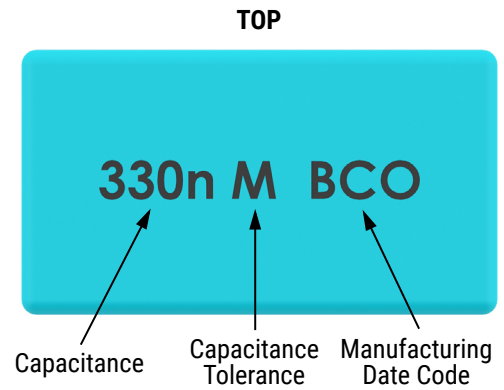
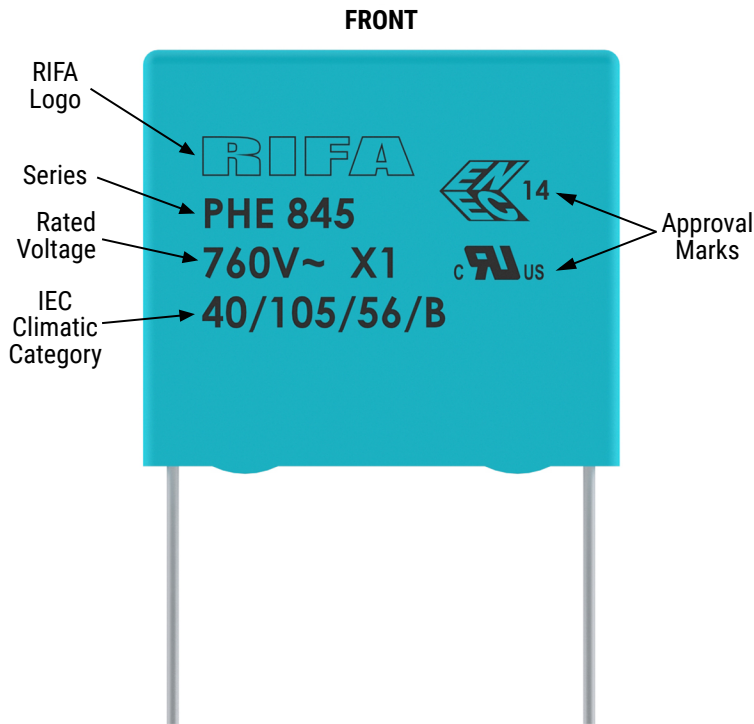

Manufacturing Date Code (IEC-60062)			
Year	Code	Month	Code
2020	M	January	1
2021	N	February	2
2022	P	March	3
2023	R	April	4
2024	S	May	5
2025	T	June	6
2026	U	July	7
2027	V	August	8
2028	W	September	9
2029	X	October	0
2030	A	November	N
2031	B	December	D
2032	C		
2033	D		
2034	E		
2035	F		
2036	H		
2037	J		
2038	K		
2039	L		
2040	M		

Metallized Polypropylene Film EMI Suppression Capacitors  
PHE845, Class X1, 760 VAC, 105°C

## Packaging Quantities

Lead Spacing	KEMET Size Code	Legacy Size Code	Thickness (mm)	Height (mm)	Length (mm)	Bulk Short Leads	Standard Reel ø 355 mm	Large Reel ø 500 mm	Ammo Bulk (Pizza)
22.5	DD	D13	6.5	14.5	26.0	234	300	600	440
	DH	D14	8.0	16.0	26.0	186	250	500	352
	DM	D15	9.0	18.5	26.0	308	250	500	308
	DT	D16	11.0	21.5	26.0	253	200	400	253
	DF	D17	7.0	16.5	26.0	216	300	600	396
	DR	D18	10.5	19.0	26.0	264	200	400	264
	DY	D19	15.5	24.5	26.0	176	110	250	176
	DW	D20	13.5	23.0	26.0	209	160	300	209
27.5	FK	F03	13.5	23.0	31.5	171		250	171
	FE	F11	10.5	20.5	31.5	216		350	216
	FG	F12	11.5	22.5	31.5	198		300	198
	FM	F13	14.5	24.5	31.5	153		250	153
	FR	F14	17.5	28.0	31.5	126			126
	FS	F15	19.0	29.0	31.5	117			117
	FV	F16	21.0	30.0	31.5	108			108
	FH	F17	21.0	12.5	31.5	108			108
	FT	F18	31.0	18.5	31.5	72			72
	FQ	F19	27.5	16.0	31.5	81			81
37.5	RK	R02	16.5	32.0	41.0	105			105
	RM	R03	19.0	36.0	41.0	91			91
	RH	R04	15.0	26.0	41.0	119			119
	RF	R05	13.0	24.0	41.0	140			140
	RP	R06	21.0	38.0	41.0	84			84
	RS	R08	28.0	43.0	41.0	54			54

## Lead Taping & Packaging (IEC 60286-2)

### Lead Spacing 22.5 – 27.5 mm

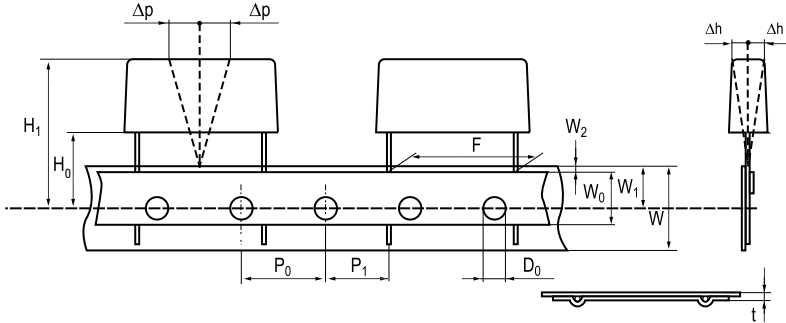

## Taping Specification

Description	Symbol	Dimensions (mm)		
		Lead Space		Tolerance
		22.5	27.5	
Lead Spacing	F	22.5	27.5	+0.6/-0.1
Carrier Tape Width	W	18	18	+1/-0.5
Hold Down Tape Width	$W_0$	5	5	Minimum
Hole Position	$W_1$	9	9	+0.75/-0.5
Hold Down Tape Position	$W_2$	3	3	Maximum
Feed Hole Diameter	$D_0$	4	4	±0.2
Feed-hole Lead Space *	$P_0$	12.7	12.7	±0.2 **
Centering of the Lead Wire	$P_1$	7.8	5.3	±0.7
Component Alignment	$\Delta h$	2	2	±2
Deviation Tape – Plane	$\Delta p$	1.3	1.3	Maximum
Tape Thickness	t	0.9	0.9	Maximum
Height of Component from Tape Center	$H_0$ ***	18.5	18.5	±0.5

\*Available also 15mm

\*\*Maximum 1 mm on 20 lead spaces

\*\*\*  $H_0 = 16.5$  mm is available upon request

## **KEMET Electronics Corporation Sales Offices**

For a complete list of our global sales offices, please visit <https://www.yageogroup.com/SalesResources/SalesOffices>

---

### **Disclaimer**

YAGEO Corporation and its affiliates do not recommend the use of commercial or automotive grade products for high reliability applications or manned space flight.

All product specifications, statements, information and data (collectively, the "Information") in this datasheet are subject to change. The customer is responsible for checking and verifying the extent to which the Information contained in this publication is applicable to an order at the time the order is placed. All Information given herein is believed to be accurate and reliable, but it is presented without guarantee, warranty, or responsibility of any kind, expressed or implied.

Statements of suitability for certain applications are based on KEMET Electronics Corporation's ("KEMET") knowledge of typical operating conditions for such applications, but are not intended to constitute – and KEMET specifically disclaims – any warranty concerning suitability for a specific customer application or use. The Information is intended for use only by customers who have the requisite experience and capability to determine the correct products for their application. Any technical advice inferred from this Information or otherwise provided by KEMET with reference to the use of KEMET's products is given gratis, and KEMET assumes no obligation or liability for the advice given or results obtained.

Although KEMET designs and manufactures its products to the most stringent quality and safety standards, given the current state of the art, isolated component failures may still occur. Accordingly, customer applications which require a high degree of reliability or safety should employ suitable designs or other safeguards (such as installation of protective circuitry or redundancies) in order to ensure that the failure of an electrical component does not result in a risk of personal injury or property damage.

Although all product-related warnings, cautions and notes must be observed, the customer should not assume that all safety measures are indicated or that other measures may not be required.

Additional information about production site flexibility can be found [<here>](#)

*KEMET is a registered trademark of KEMET Electronics Corporation.*

## Looking for pricing, stock, or lifecycle information?

Click below to explore more details on WIN SOURCE:

 [View PHE845VY6220MR30L2 on WIN SOURCE](#)

 [Kemet Information](#)

## Optimize Your Supply Chain with WIN SOURCE Solutions

-  Global Sourcing Solution
-  Obsolete Management
-  Cost Control Management
-  Shortage Management
-  Alternative Solution
-  Excess Inventory Management