



**THE DATASHEET OF
PCA9552D,118**



PCA9552

16-bit I²C-bus LED driver with programmable blink rates

Rev. 5.1 — 25 May 2023

Product data sheet



1 General description

The PCA9552 LED blinker blinks LEDs in I²C-bus and SMBus applications where it is necessary to limit bus traffic or free up the I²C-bus controller's (MCU, MPU, DSP, chip set, etc.) timer. The uniqueness of this device is the internal oscillator with two programmable blink rates. To blink LEDs using normal I/O expanders like the PCF8574 or PCA9554, the bus controller must send repeated commands to turn the LED on and off. This greatly increases the amount of traffic on the I²C-bus and uses up one of the controller's timers. The PCA9552 LED blinker instead requires only the initial setup command to program BLINK RATE 1 and BLINK RATE 2 (that is, the frequency and duty cycle) for each individual output. From then on, only one command from the bus controller is required to turn each individual open-drain output on, off, or to cycle at BLINK RATE 1 or BLINK RATE 2. Maximum output sink current is 25 mA per bit and 200 mA per package.

Any bits not used for controlling the LEDs can be used for General Purpose Parallel Input/Output (GPIO) expansion.

The active LOW hardware reset pin ($\overline{\text{RESET}}$) and Power-On Reset (POR) initializes the registers to their default state, all zeroes, causing the bits to be set HIGH (LED off).

Three hardware address pins on the PCA9552 allow eight devices to operate on the same bus.

2 Features

- 16 LED drivers (on, off, flashing at a programmable rate)
- 2 selectable, fully programmable blink rates (frequency and duty cycle) between 0.172 Hz and 44 Hz (5.82 seconds and 0.023 seconds)
- Input/outputs not used as LED drivers can be used as regular GPIOs
- Internal oscillator requires no external components
- I²C-bus interface logic compatible with SMBus
- Internal power-on reset
- Noise filter on SCL/SDA inputs
- Active LOW reset input
- 16 open-drain outputs directly drive LEDs to 25 mA
- Edge rate control on outputs
- No glitch on power-up
- Supports hot insertion
- Low standby current
- Operating power supply voltage range of 2.3 V to 5.5 V
- 0 Hz to 400 kHz clock frequency
- ESD protection exceeds 2000 V HBM per JESD22-A114, 150 V MM per JESD22-A115 and 1000 V CDM per JESD22-C101
- Latch-up testing is done to JEDEC Standard JESD78 which exceeds 100 mA



- Packages offered: SO24, TSSOP24, HVQFN24

3 Ordering information

Table 1. Ordering information

Type number	Topside mark	Package		
		Name	Description	Version
PCA9552D	PCA9552D	SO24	plastic small outline package; 24 leads; body width 7.5 mm	SOT137-1
PCA9552PW	PCA9552	TSSOP24	plastic thin shrink small outline package; 24 leads; body width 4.4 mm	SOT355-1
PCA9552BS	9552	HVQFN24	plastic thermal enhanced very thin quad flat package; no leads; 24 terminals; body 4 × 4 × 0.85 mm	SOT616-1

3.1 Ordering options

Table 2. Ordering options

Type number	Orderable part number	Package	Packing method ^[1]	Minimum order quantity	Temperature
PCA9552D	PCA9552D,118	SO24	REEL 13" Q1 NDP	1000	T _{amb} = -40 °C to +85 °C
PCA9552PW	PCA9552PW,118	TSSOP24	REEL 13" Q1 NDP	2500	T _{amb} = -40 °C to +85 °C
PCA9552BS	PCA9552BS,118	HVQFN24	REEL 13" Q1 NDP	6000	T _{amb} = -40 °C to +85 °C

[1] Standard packing quantities and other packaging data are available at www.nxp.com/packages/.

4 Block diagram

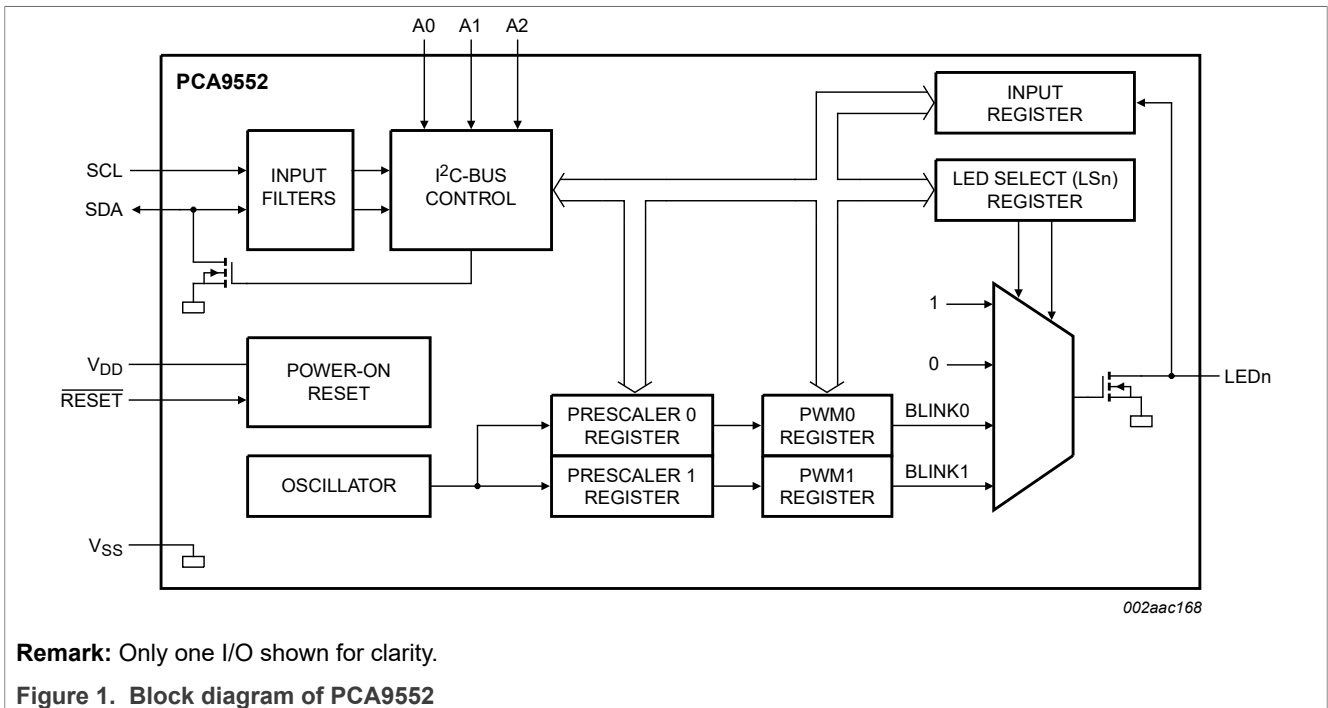

Remark: Only one I/O shown for clarity.

Figure 1. Block diagram of PCA9552

5 Pinning information

5.1 Pinning

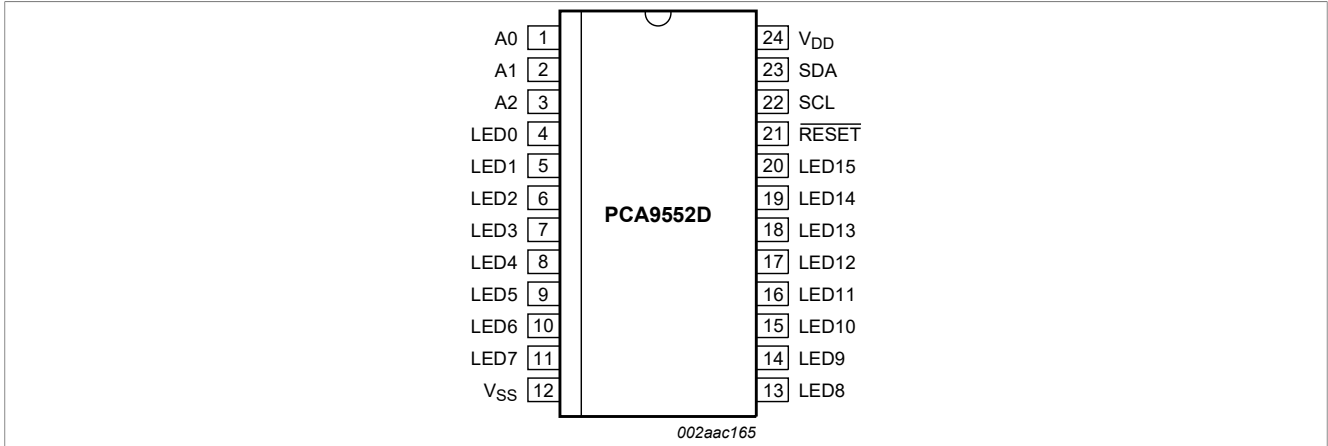

Figure 2. Pin configuration for SO24

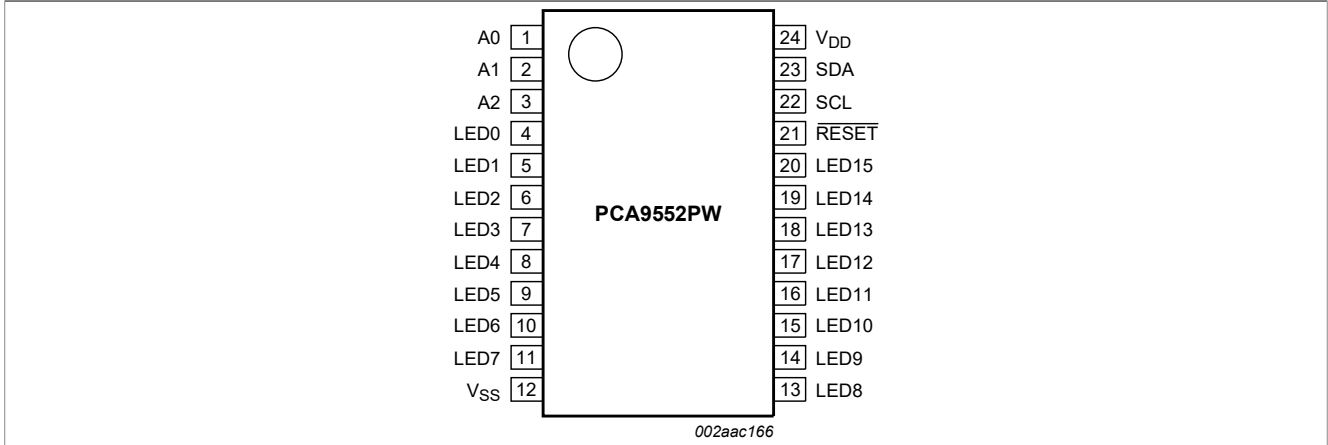

Figure 3. Pin configuration for TSSOP24

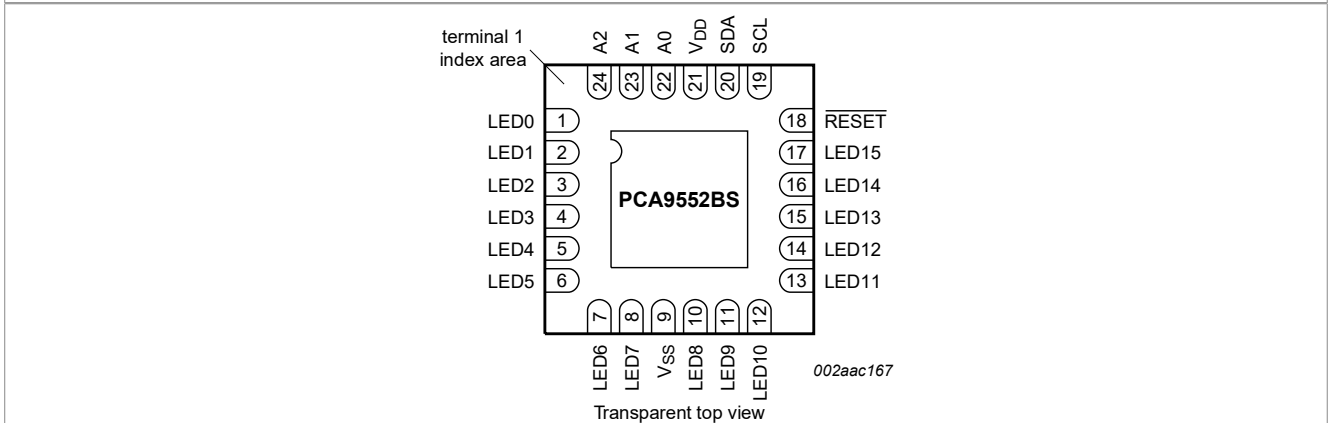

Figure 4. Pin configuration for HVQFN24

5.2 Pin description

Table 3. Pin description

Symbol	Pin		Description
	SO24, TSSOP24	HVQFN24	
A0	1	22	address input 0
A1	2	23	address input 1
A2	3	24	address input 2
LED0	4	1	LED driver 0
LED1	5	2	LED driver 1
LED2	6	3	LED driver 2
LED3	7	4	LED driver 3
LED4	8	5	LED driver 4
LED5	9	6	LED driver 5
LED6	10	7	LED driver 6
LED7	11	8	LED driver 7
V _{SS}	12	9 ^[1]	ground supply
LED8	13	10	LED driver 8
LED9	14	11	LED driver 9
LED10	15	12	LED driver 10
LED11	16	13	LED driver 11
LED12	17	14	LED driver 12
LED13	18	15	LED driver 13
LED14	19	16	LED driver 14
LED15	20	17	LED driver 15
RESET	21	18	active LOW reset input
SCL	22	19	serial clock line
SDA	23	20	serial data line
V _{DD}	24	21	supply voltage

[1] HVQFN package die supply ground is connected to both V_{SS} pin and exposed center pad. V_{SS} pin must be connected to supply ground for proper device operation. For enhanced thermal, electrical, and board level performance, the exposed pad needs to be soldered to the board using a corresponding thermal pad on the board and for proper heat conduction through the board, thermal vias need to be incorporated in the printed-circuit board in the thermal pad region.

6 Functional description

Refer to [Figure 1](#).

6.1 Device address

Following a START condition, the bus controller must output the address of the target it is accessing. The address of the PCA9552 is shown in [Figure 5](#). To conserve power, no internal pull-up resistors are incorporated on the hardware selectable address pins and they must be pulled HIGH or LOW.

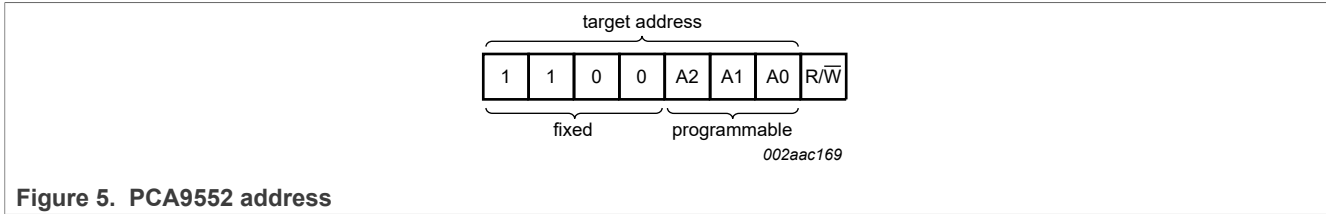
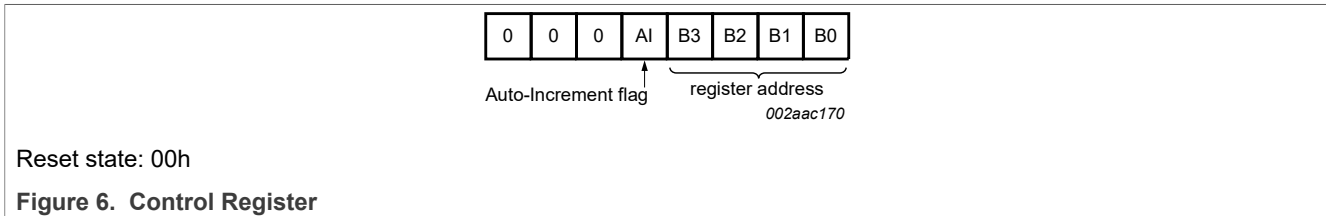

Figure 5. PCA9552 address

The last bit of the address byte defines the operation to be performed. When set to logic 1 a read is selected, while a logic 0 selects a write operation.

6.2 Control Register

Following the successful acknowledgement of the target address, the bus controller will send a byte to the PCA9552, which will be stored in the Control Register. This register can be read and written via the I²C-bus.



Reset state: 00h

Figure 6. Control Register

The lowest 3 bits are used as a pointer to determine which register will be accessed.

If the Auto-Increment flag (AI) is set, the four low order bits of the Control Register are automatically incremented after a read or write. This allows the user to program the registers sequentially. The contents of these bits will rollover to '0000' after the last register is accessed.

When the Auto-Increment flag is set (AI = 1) and a read sequence is initiated, the sequence must start by reading a register different from '0' (B3 B2 B1 B0 ≠ 0000).

Only the 4 least significant bits are affected by the AI flag. Unused bits must be programmed with zeroes.

6.2.1 Control Register definition

Table 4. Register summary

B3	B2	B1	B0	Symbol	Access	Description
0	0	0	0	INPUT0	read only	input register 0
0	0	0	1	INPUT1	read only	input register 1
0	0	1	0	PSC0	read/write	frequency prescaler 0
0	0	1	1	PWM0	read/write	PWM register 0
0	1	0	0	PSC1	read/write	frequency prescaler 1
0	1	0	1	PWM1	read/write	PWM register 1
0	1	1	0	LS0	read/write	LED0 to LED3 selector
0	1	1	1	LS1	read/write	LED4 to LED7 selector
1	0	0	0	LS2	read/write	LED8 to LED11 selector
1	0	0	1	LS3	read/write	LED12 to LED15 selector

6.3 Register descriptions

6.3.1 INPUT0 - Input register 0

The Input register 0 reflects the state of the device pins (inputs LED0 to LED7). Writes to this register will be acknowledged but will have no effect.

Table 5. INPUT0 - input register 0 description

Bit	7	6	5	4	3	2	1	0
Symbol	LED7	LED6	LED5	LED4	LED3	LED2	LED1	LED0
Default	X	X	X	X	X	X	X	X

Remark: The default value 'X' is determined by the externally applied logic level (normally logic 1) when used for directly driving LED with pull-up to V_{DD}.

6.3.2 INPUT1 - Input register 1

The Input register 1 reflects the state of the device pins (inputs LED8 to LED15). Writes to this register will be acknowledged but will have no effect.

Table 6. INPUT1 - input register 1 description

Bit	7	6	5	4	3	2	1	0
Symbol	LED15	LED14	LED13	LED12	LED11	LED10	LED9	LED8
Default	X	X	X	X	X	X	X	X

Remark: The default value 'X' is determined by the externally applied logic level (normally logic 1) when used for directly driving LED with pull-up to V_{DD}.

6.3.3 PCS0 - Frequency Prescaler 0

PSC0 is used to program the period of the PWM output.

The period of BLINK0 = (PSC0 + 1) / 44.

Table 7. PSC0 - Frequency Prescaler 0 register description

Bit	7	6	5	4	3	2	1	0
Symbol	PSC0[7]	PSC0[6]	PSC0[5]	PSC0[4]	PSC0[3]	PSC0[2]	PSC0[1]	PSC0[0]
Default	1	1	1	1	1	1	1	1

6.3.4 PWM0 - Pulse Width Modulation 0

The PWM0 register determines the duty cycle of BLINK0. The outputs are LOW (LED off) when the count is less than the value in PWM0 and HIGH when it is greater. If PWM0 is programmed with 00h, then the PWM0 output is always LOW.

The duty cycle of BLINK0 = (256 - PWM0) / 256.

Table 8. PWM0 - Pulse Width Modulation 0 register description

Bit	7	6	5	4	3	2	1	0
Symbol	PWM0 [7]	PWM0 [6]	PWM0 [5]	PWM0 [4]	PWM0 [3]	PWM0 [2]	PWM0 [1]	PWM0 [0]

Table 8. PWM0 - Pulse Width Modulation 0 register description...continued

Bit	7	6	5	4	3	2	1	0
Default	1	0	0	0	0	0	0	0

6.3.5 PCS1 - Frequency Prescaler 1

PSC1 is used to program the period of the PWM output.

The period of BLINK1 = (PSC1 + 1) / 44.

Table 9. PSC1 - Frequency Prescaler 1 register description

Bit	7	6	5	4	3	2	1	0
Symbol	PSC1[7]	PSC1[6]	PSC1[5]	PSC1[4]	PSC1[3]	PSC1[2]	PSC1[1]	PSC1[0]
Default	1	1	1	1	1	1	1	1

6.3.6 PWM1 - Pulse Width Modulation 1

The PWM1 register determines the duty cycle of BLINK1. The outputs are LOW (LED off) when the count is less than the value in PWM1 and HIGH when it is greater. If PWM1 is programmed with 00h, then the PWM1 output is always LOW.

The duty cycle of BLINK1 = (256 - PWM1) / 256.

Table 10. PWM1 - Pulse Width Modulation 1 register description

Bit	7	6	5	4	3	2	1	0
Symbol	PWM1 [7]	PWM1 [6]	PWM1 [5]	PWM1 [4]	PWM1 [3]	PWM1 [2]	PWM1 [1]	PWM1 [0]
Default	1	0	0	0	0	0	0	0

6.3.7 LS0 to LS3 - LED selector registers

The LSn LED select registers determine the source of the LED data.

- 00 = output is set LOW (LED on)
- 01 = output is set high-impedance (LED off; default)
- 10 = output blinks at PWM0 rate
- 11 = output blinks at PWM1 rate

Table 11. LS0 to LS3 - LED selector registers bit description

Legend: * default value

Register	Bit	Value	Description
LS0 - LED0 to LED3 selector			
LS0	7:6	01*	LED3 selected
	5:4	01*	LED2 selected
	3:2	01*	LED1 selected
	1:0	01*	LED0 selected
LS1 - LED4 to LED7 selector			
LS1	7:6	01*	LED7 selected

Table 11. LS0 to LS3 - LED selector registers bit description...continued

Legend: * default value

Register	Bit	Value	Description
	5:4	01*	LED6 selected
	3:2	01*	LED5 selected
	1:0	01*	LED4 selected
LS2 - LED8 to LED11 selector			
LS2	7:6	01*	LED11 selected
	5:4	01*	LED10 selected
	3:2	01*	LED9 selected
	1:0	01*	LED8 selected
LS3 - LED12 to LED15 selector			
LS3	7:6	01*	LED15 selected
	5:4	01*	LED14 selected
	3:2	01*	LED13 selected
	1:0	01*	LED12 selected

6.4 Pins used as GPIOs

LED pins not used to control LEDs can be used as general purpose I/Os (GPIOs).

For use as input, set LED_n to high-impedance (01) and then read the pin state via the input register.

For use as output, connect external pull-up resistor to the pin and size it according to the DC recommended operating characteristics. LED output pin is HIGH when the output is programmed as high-impedance, and LOW when the output is programmed LOW through the 'LED selector' register. The output can be pulse-width controlled when PWM0 or PWM1 are used.

6.5 Power-on reset

When power is applied to V_{DD}, an internal Power-On Reset (POR) holds the PCA9552 in a reset condition until V_{DD} has reached V_{POR}. At that point, the reset condition is released and the PCA9552 registers are initialized to their default states. Thereafter, V_{DD} must be lowered below 0.2 V to reset the device.

6.6 External RESET

A reset can be accomplished by holding the $\overline{\text{RESET}}$ pin LOW for a minimum of $t_{w(\text{rst})}$. The PCA9552 registers and I²C-bus state machine will be held in their default states until the $\overline{\text{RESET}}$ input is once again HIGH.

This input requires a pull-up resistor to V_{DD} if no active connection is used.

7 Characteristics of the I²C-bus

The I²C-bus is for 2-way, 2-line communication between different ICs or modules. The two lines are a serial data line (SDA) and a serial clock line (SCL). Both lines must be connected to a positive supply via a pull-up resistor when connected to the output stages of a device. Data transfer may be initiated only when the bus is not busy.

7.1 Bit transfer

One data bit is transferred during each clock pulse. The data on the SDA line must remain stable during the HIGH period of the clock pulse as changes in the data line at this time will be interpreted as control signals (see [Figure 7](#)).

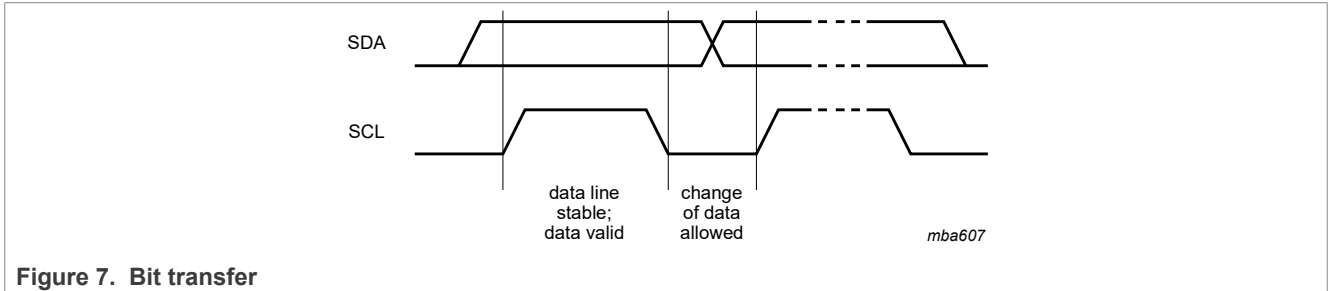

7.1.1 START and STOP conditions

Both data and clock lines remain HIGH when the bus is not busy. A HIGH-to-LOW transition of the data line while the clock is HIGH is defined as the START condition (S). A LOW-to-HIGH transition of the data line while the clock is HIGH is defined as the STOP condition (P) (see [Figure 8](#).)

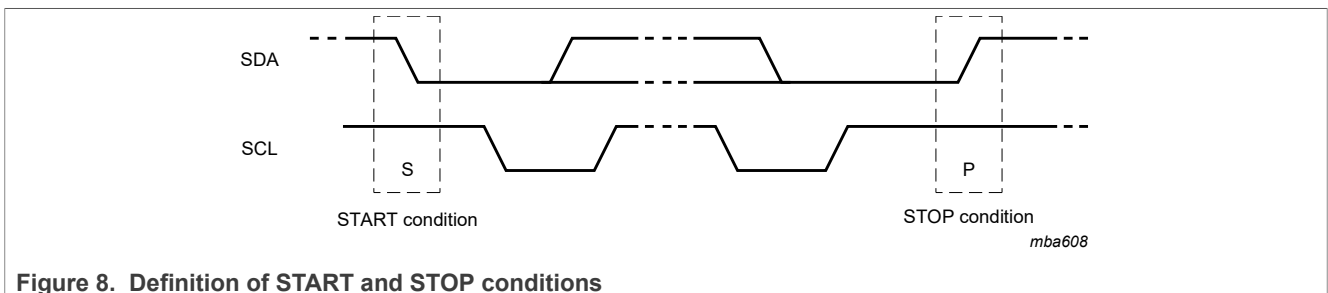

7.2 System configuration

A device generating a message is a 'transmitter'; a device receiving is the 'receiver'. The device that controls the message is the 'controller' and the devices which are controlled by the controller are the 'targets' (see [Figure 9](#)).

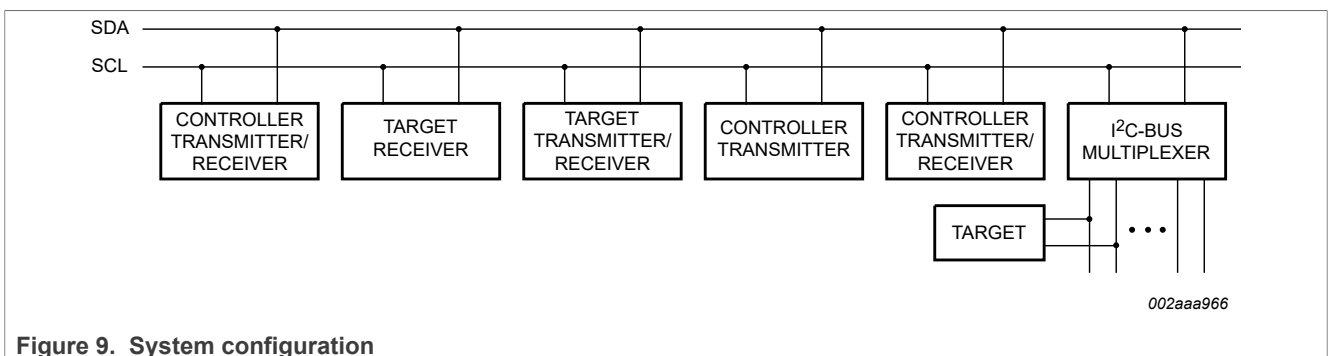

7.3 Acknowledge

The number of data bytes transferred between the START and the STOP conditions from transmitter to receiver is not limited. Each byte of eight bits is followed by one acknowledge bit. The acknowledge bit is a HIGH level put on the bus by the transmitter, whereas the controller generates an extra acknowledge related clock pulse.

A target receiver which is addressed must generate an acknowledge after the reception of each byte. Also a controller must generate an acknowledge after the reception of each byte that has been clocked out of the target transmitter. The device that acknowledges has to pull down the SDA line during the acknowledge clock pulse, so that the SDA line is stable LOW during the HIGH period of the acknowledge related clock pulse; set-up and hold times must be taken into account.

A controller receiver must signal an end of data to the transmitter by not generating an acknowledge on the last byte that has been clocked out of the target. In this event, the transmitter must leave the data line HIGH to enable the controller to generate a STOP condition.

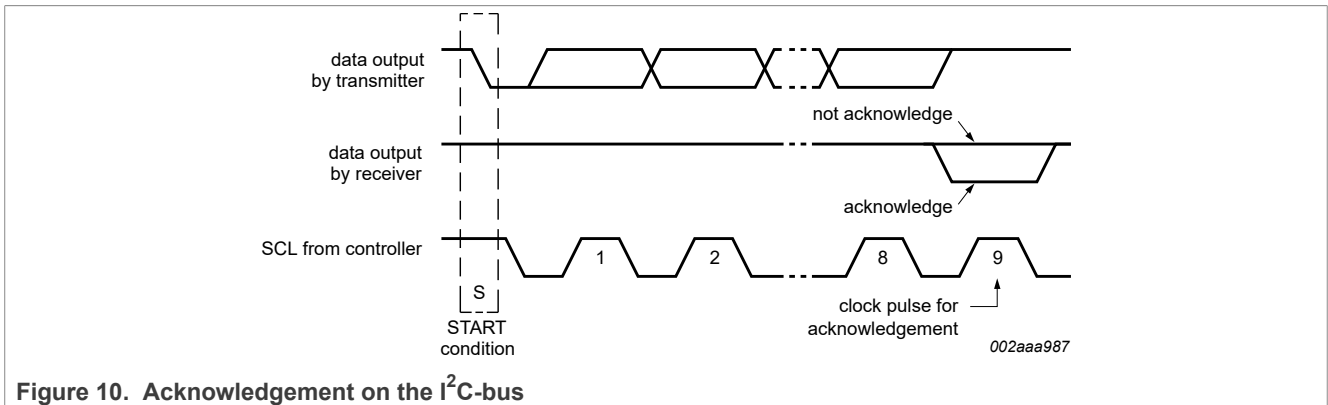

Figure 10. Acknowledgement on the I²C-bus

7.4 Bus transactions

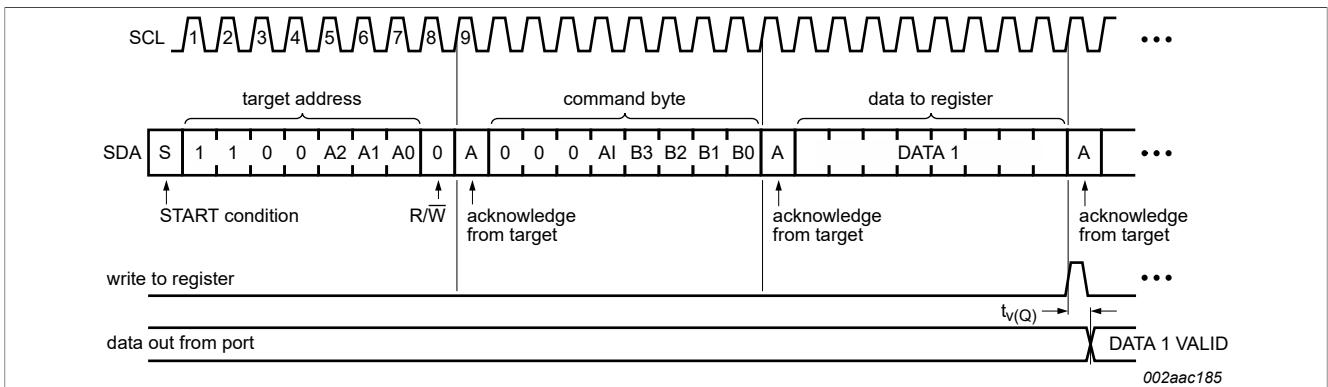

Figure 11. Write to register

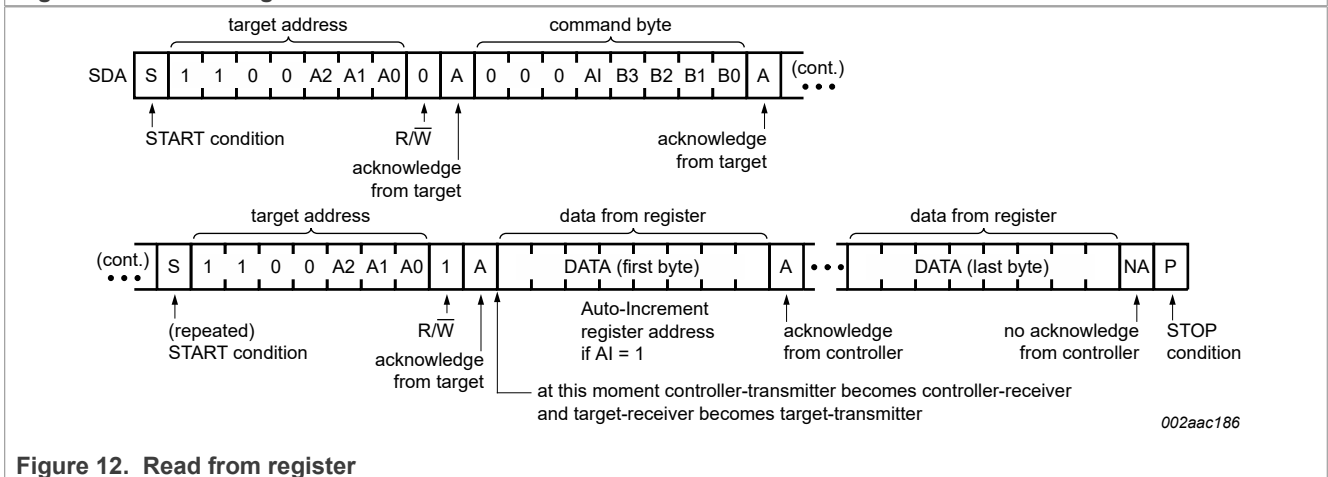
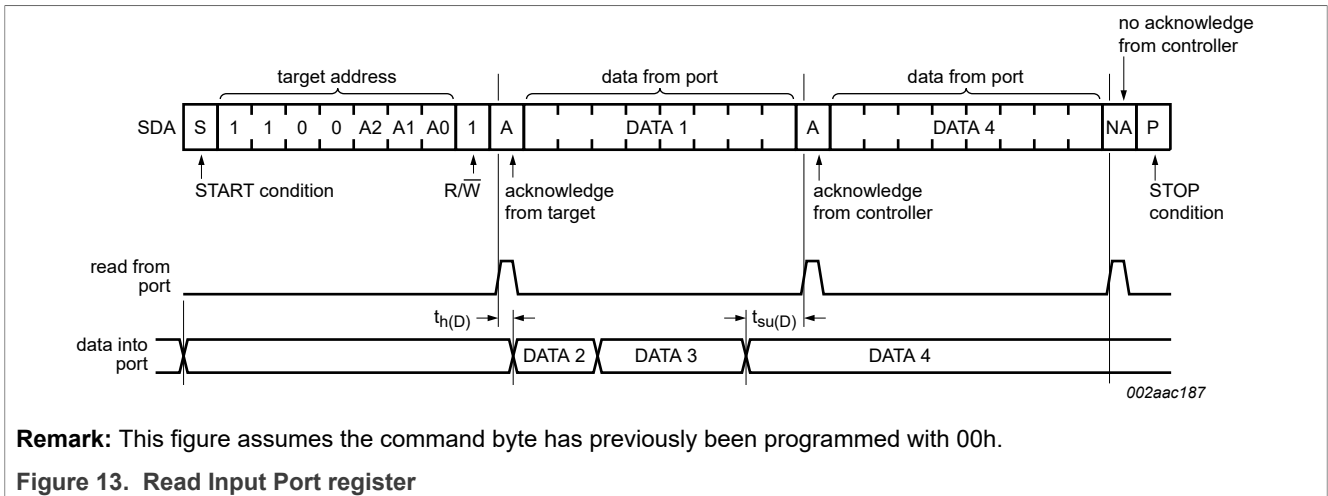
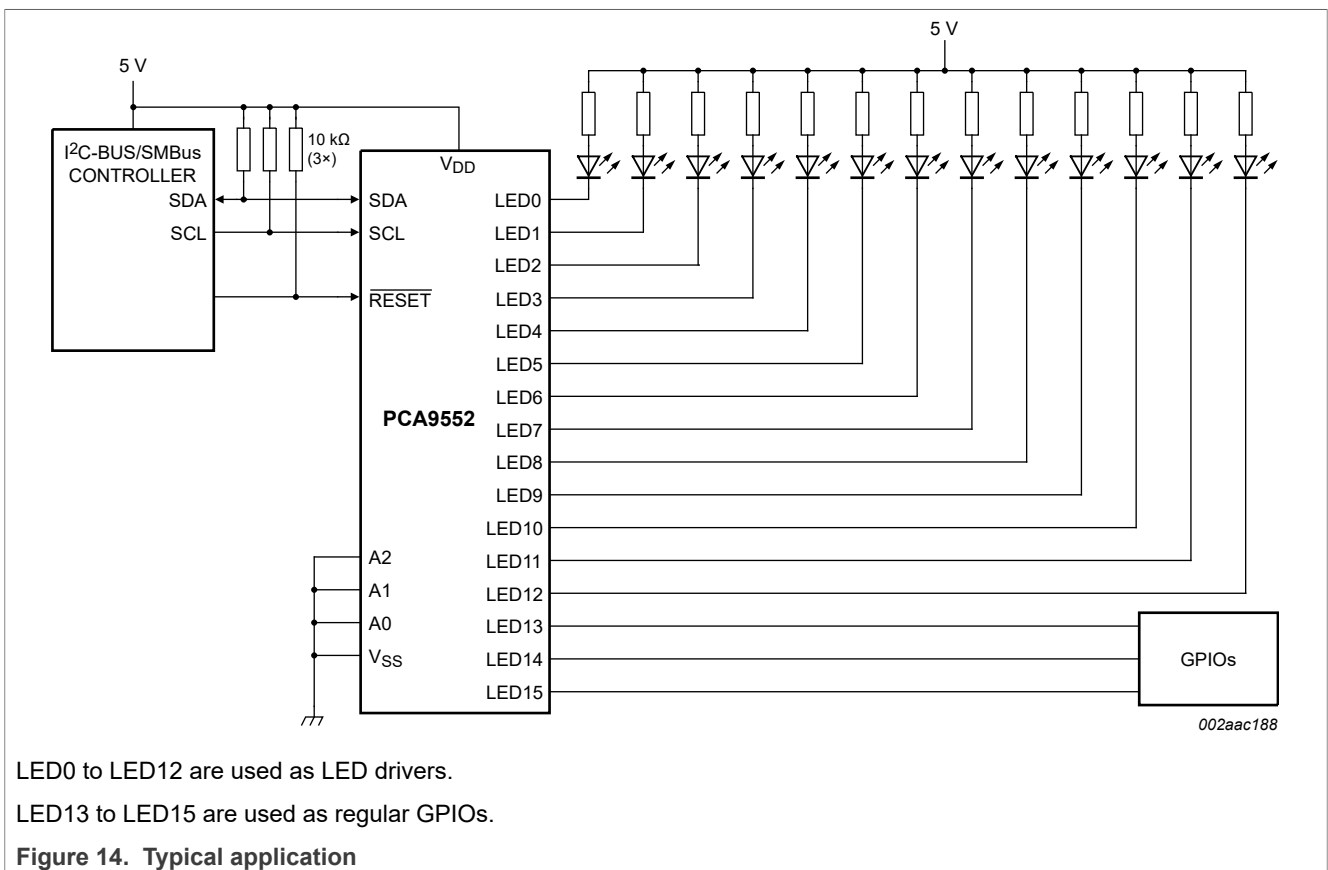

Figure 12. Read from register



8 Application design-in information



8.1 Minimizing I_{DD} when the I/O is used to control LEDs

When the I/Os are used to control LEDs, they are normally connected to V_{DD} through a resistor as shown in [Figure 15](#). Since the LED acts as a diode, when the LED is off the I/O V_I is about 1.2 V less than V_{DD}. The supply current, I_{DD}, increases as V_I becomes lower than V_{DD} and is specified as ΔI_{stb} in [Table 14](#).

Designs needing to minimize current consumption, such as battery power applications, should consider maintaining the I/O pins greater than or equal to V_{DD} when the LED is off. Figure 15 shows a high value resistor in parallel with the LED. Figure 16 shows V_{DD} less than the LED supply voltage by at least 1.2 V. Both of these methods maintain the input/output V_I at or above V_{DD} and prevents additional supply current consumption when the LED is off.

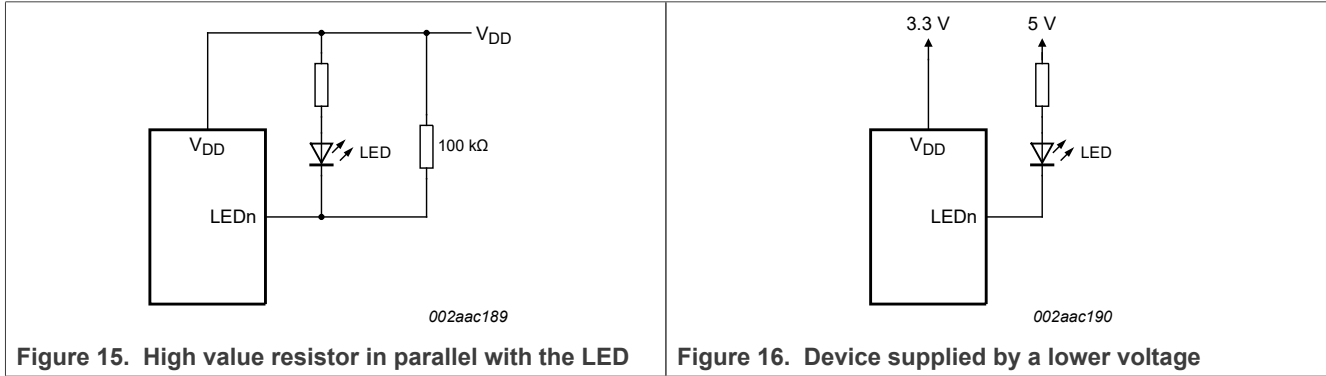

8.2 Programming example

The following example will show how to set LED0 to LED3 on. It will then set LED4 and LED5 to blink at 1 Hz at a 50 % duty cycle. LED6 and LED7 will be set to blink at 4 Hz and at a 25 % duty cycle. LED8 to LED15 will be set to off.

Table 12. Programming PCA9552

Program sequence	I ² C-bus
START	S
PCA9552 address with A0 to A2 = LOW	C0h
PSC0 subaddress + Auto-Increment	12h
Set prescaler PSC0 to achieve a period of 1 second: Blink period = $1 = \frac{PSC0+1}{44}$ PSC0 = 43	2Bh
Set PWM0 duty cycle to 50 %: $\frac{256-PWM0}{256} = 0.5$ PWM0 = 128	80h
Set prescaler PCS1 to achieve a period of 0.25 seconds: Blink period = $0.25 = \frac{PSC1+1}{44}$ PSC1 = 10	0Ah
Set PWM1 output duty cycle to 25 %: $\frac{256-PWM1}{256} = 0.25$ PWM1 = 192	C0h
Set LED0 to LED3 on	00h
Set LED4 and LED5 to PWM0, and LED6 or LED7 to PWM1	FAh
Set LED8 to LED11 off	55h
Set LED12 to LED15 off	55h
STOP	P

9 Limiting values

Table 13. Limiting values

In accordance with the Absolute Maximum Rating System (IEC 60134).

Symbol	Parameter	Conditions	Min	Max	Unit
V _{DD}	supply voltage		-0.5	+6.0	V
V _{I/O}	voltage on an input/output pin	LEDn used as an I/O	V _{SS} - 0.5	5.5	V
I _{O(LEDn)}	output current on pin LEDn	LEDn used as an I/O	-	± 25	mA
I _{SS}	ground supply current		-	200	mA
P _{tot}	total power dissipation		-	400	mW
T _{stg}	storage temperature		-65	+150	° C
T _{amb}	ambient temperature	operating	-40	+85	° C

10 Static characteristics

Table 14. Static characteristics

V_{DD} = 2.3 V to 5.5 V; V_{SS} = 0 V; T_{amb} = -40 ° C to +85 ° C; unless otherwise specified.

Symbol	Parameter	Conditions	Min	Typ ^[1]	Max	Unit
Supply						
V _{DD}	supply voltage		2.3	-	5.5	V
I _{DD}	supply current	Operating mode; V _{DD} = 5.5 V; no load; V _I = V _{DD} or V _{SS} ; f _{SCL} = 100 kHz	-	350	550	µA
I _{stb}	standby current	Standby mode; V _{DD} = 5.5 V; no load; V _I = V _{DD} or V _{SS} ; f _{SCL} = 0 kHz	-	2.1	5.0	µA
ΔI _{stb}	additional standby current	Standby mode; V _{DD} = 5.5 V; every LED I/O at V _I = 4.3 V; f _{SCL} = 0 kHz	-	-	2	mA
V _{POR}	power-on reset voltage ^[2]	V _{DD} = 3.3 V; no load; V _I = V _{DD} or V _{SS}	-	1.7	2.2	V
Input SCL; input/output SDA						
V _{IL}	LOW-level input voltage		-0.5	-	0.3V _{DD}	V
V _{IH}	HIGH-level input voltage		0.7V _{DD}	-	5.5	V
I _{OL}	LOW-level output current	V _{OL} = 0.4 V	3	6.5	-	mA
I _L	leakage current	V _I = V _{DD} = V _{SS}	-1	-	+1	µA
C _i	input capacitance	V _I = V _{SS}	-	4.4	5	pF
I/Os						
V _{IL}	LOW-level input voltage		-0.5	-	0.8	V
V _{IH}	HIGH-level input voltage		2.0	-	5.5	V
I _{OL}	LOW-level output current	V _{OL} = 0.4 V; V _{DD} = 2.3 V	^[3] 9	-	-	mA
		V _{OL} = 0.4 V; V _{DD} = 3.0 V	^[3] 12	-	-	mA
		V _{OL} = 0.4 V; V _{DD} = 5.0 V	^[3] 15	-	-	mA
		V _{OL} = 0.7 V; V _{DD} = 2.3 V	^[3] 15	-	-	mA

Table 14. Static characteristics...continued

V_{DD} = 2.3 V to 5.5 V; V_{SS} = 0 V; T_{amb} = -40 °C to +85 °C; unless otherwise specified.

Symbol	Parameter	Conditions	Min	Typ ^[1]	Max	Unit
		V _{OL} = 0.7 V; V _{DD} = 3.0 V	[3] 20	-	-	mA
		V _{OL} = 0.7 V; V _{DD} = 5.0 V	[3] 25	-	-	mA
I _{LI}	input leakage current	V _{DD} = 3.6 V; V _I = 0 V or V _{DD}	-1	-	+1	µA
C _{io}	input/output capacitance		-	2.6	5	pF
Select inputs A0, A1, A2; RESET						
V _{IL}	LOW-level input voltage		-0.5	-	0.8	V
V _{IH}	HIGH-level input voltage		2.0	-	5.5	V
I _{LI}	input leakage current		-1	-	+1	µA
C _i	input capacitance	V _I = V _{SS}	-	2.3	5	pF

- [1] All typical values at 3.3 V and 25 °C.
- [2] V_{DD} must be lowered to 0.2 V in order to reset part.
- [3] Each I/O must be externally limited to a maximum of 25 mA and each octal ([LED0 to LED7] and [LED8 to LED15]) must be limited to a maximum current of 100 mA for a device total of 200 mA.

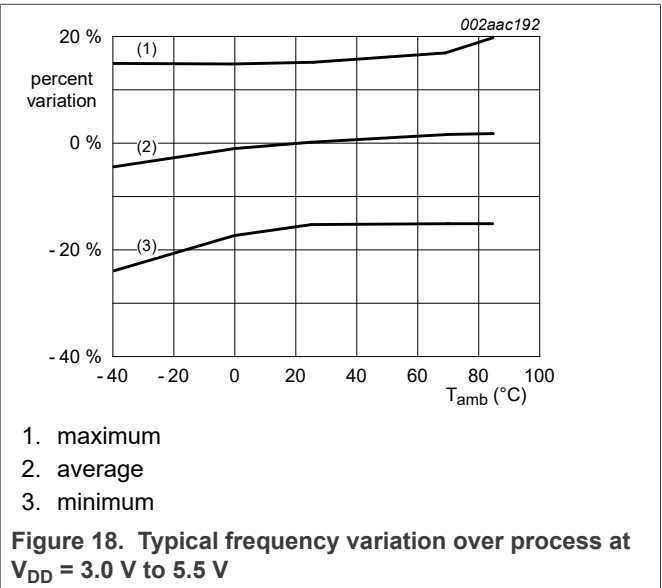
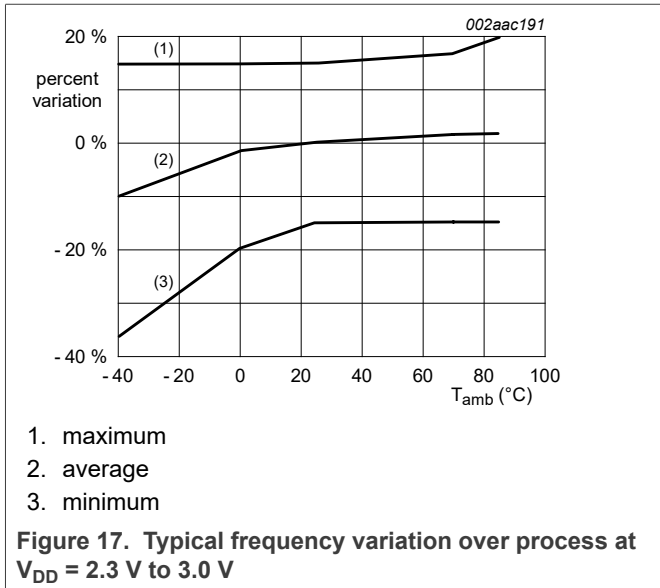

11 Dynamic characteristics

Table 15. Dynamic characteristics

Symbol	Parameter	Conditions	Standard mode I ² C-bus		Fast mode I ² C-bus		Unit
			Min	Max	Min	Max	
f _{SCL}	SCL clock frequency		0	100	0	400	kHz
t _{BUF}	bus free time between a STOP and START condition		4.7	-	1.3	-	µs

Table 15. Dynamic characteristics...continued

Symbol	Parameter	Conditions		Standard mode I ² C-bus		Fast mode I ² C-bus		Unit
				Min	Max	Min	Max	
t _{HD;STA}	hold time (repeated) START condition			4.0	-	0.6	-	μs
t _{SU;STA}	set-up time for a repeated START condition			4.7	-	0.6	-	μs
t _{SU;STO}	set-up time for STOP condition			4.0	-	0.6	-	μs
t _{HD;DAT}	data hold time			0	-	0	-	ns
t _{VD;ACK}	data valid acknowledge time		[1]	-	600	-	600	ns
t _{VD;DAT}	data valid time	LOW-level	[2]	-	600	-	600	ns
		HIGH-level	[2]	-	1500	-	600	ns
t _{SU;DAT}	data set-up time			250	-	100	-	ns
t _{LOW}	LOW period of the SCL clock			4.7	-	1.3	-	μs
t _{HIGH}	HIGH period of the SCL clock			4.0	-	0.6	-	μs
t _f	fall time of both SDA and SCL signals			-	300	20 + 0.1C _b ^[3]	300	ns
t _r	rise time of both SDA and SCL signals			-	1000	20 + 0.1C _b ^[3]	300	ns
t _{SP}	pulse width of spikes that must be suppressed by the input filter			-	50	-	50	ns
Port timing								
t _{V(Q)}	data output valid time			-	250	-	250	ns
t _{SU(D)}	data input setup time			100	-	100	-	ns
t _{H(D)}	data input hold time			1	-	1	-	μs
Reset								
t _{w(rst)}	reset pulse width			10	-	10	-	ns
t _{rec(rst)}	reset recovery time			0	-	0	-	ns
t _{rst}	reset time		[4][5]	400	-	400	-	ns

[1] t_{VD;ACK} = time for Acknowledgement signal from SCL LOW to SDA (out) LOW.

[2] t_{VD;DAT} = minimum time for SDA data out to be valid following SCL LOW.

[3] C_b = total capacitance of one bus line in pF.

[4] Resetting the device while actively communicating on the bus may cause glitches or errant STOP conditions.

[5] Upon reset, the full delay will be the sum of t_{rst} and the RC time constant of the SDA bus.

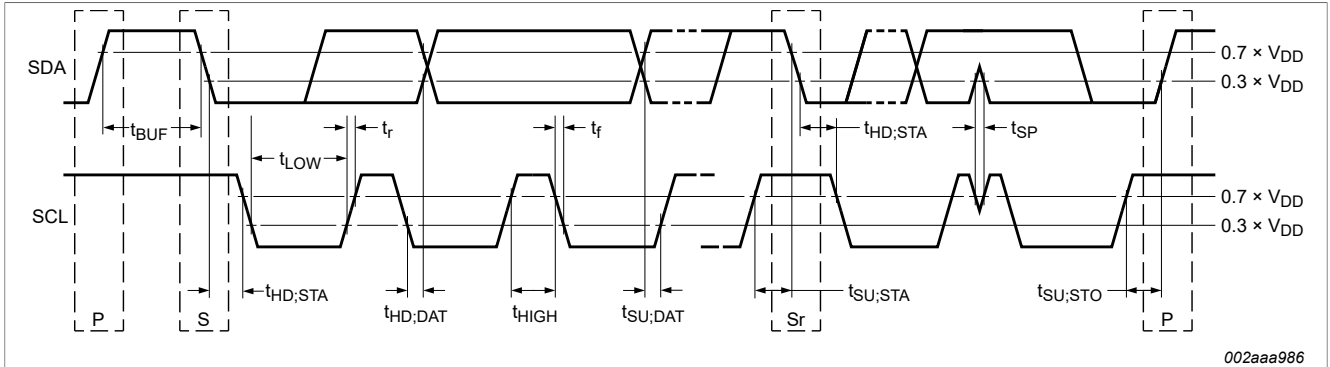
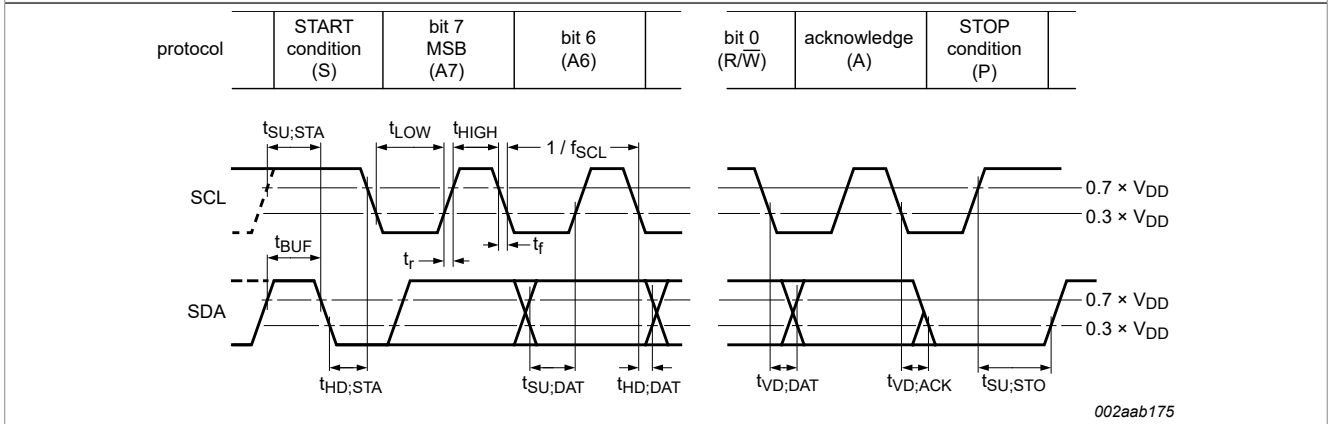

Figure 19. Definition of timing on the I²C-bus



Rise and fall times refer to V_{IL} and V_{IH} .

Figure 20. I²C-bus timing diagram

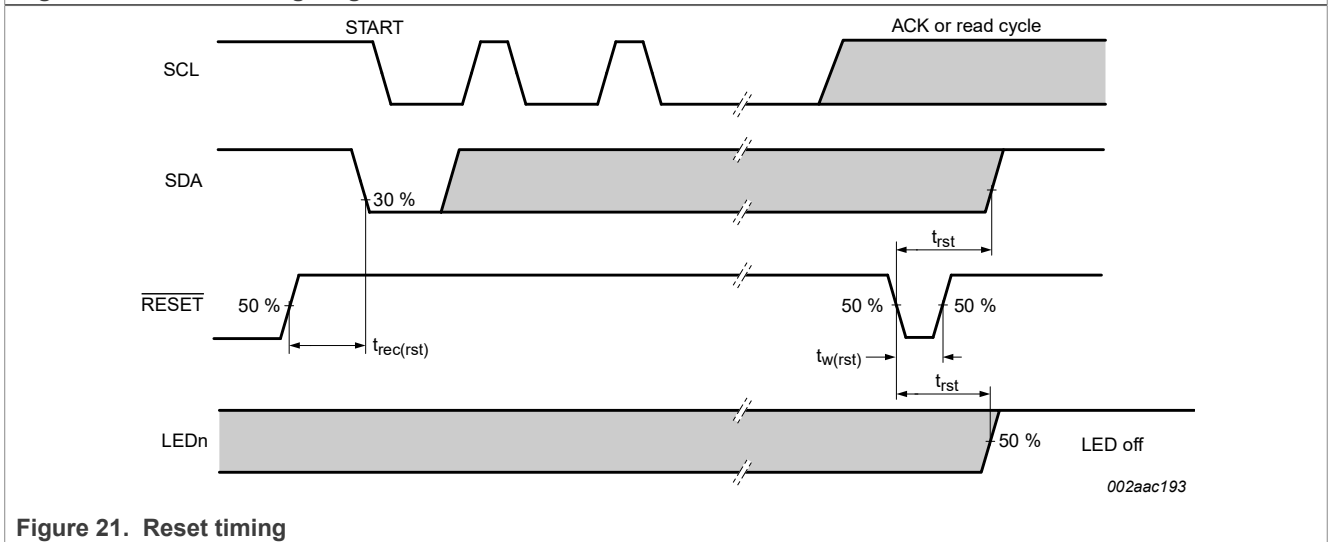
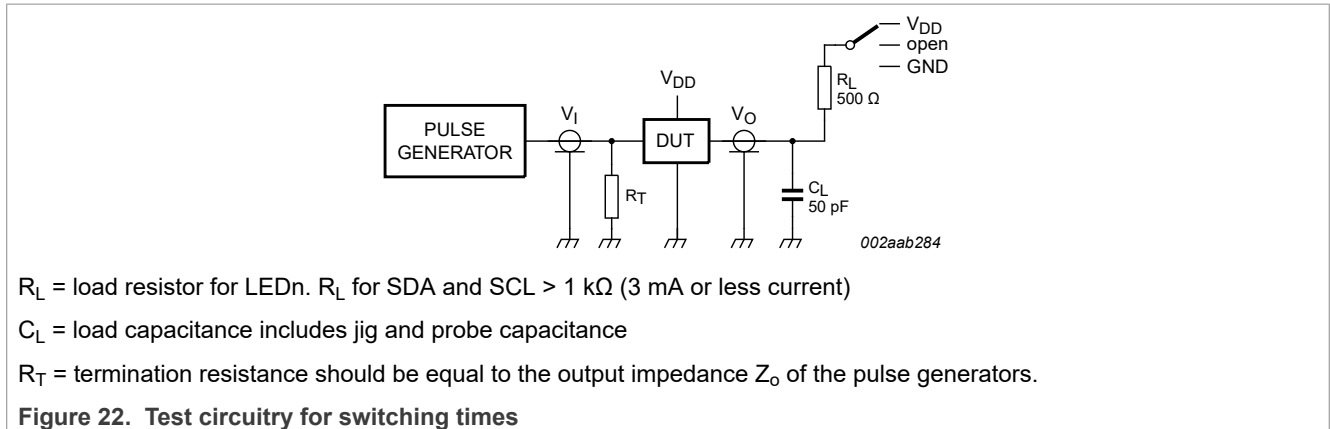

Figure 21. Reset timing

12 Test information



13 Package outline

SO24: plastic small outline package; 24 leads; body width 7.5 mm

SOT137-1

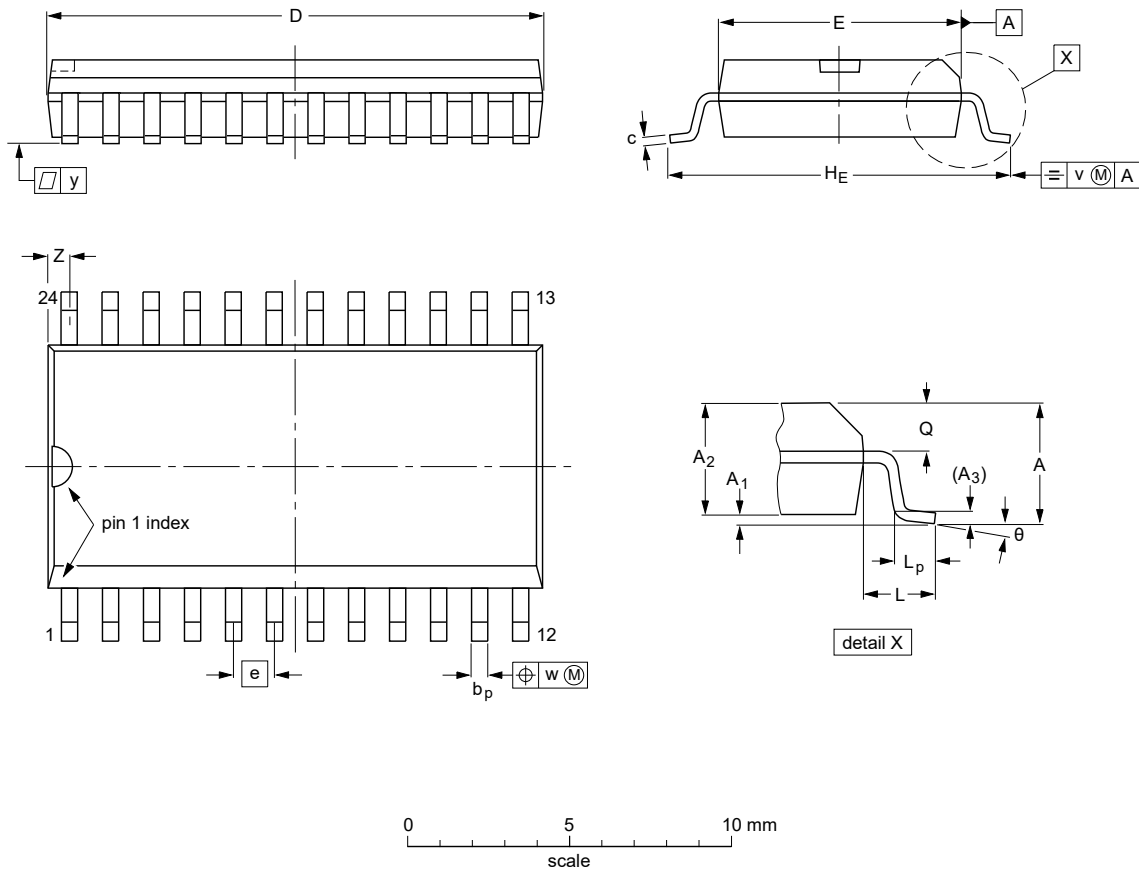

DIMENSIONS (inch dimensions are derived from the original mm dimensions)

UNIT	A max.	A ₁	A ₂	A ₃	b _p	c	D ⁽¹⁾	E ⁽¹⁾	e	H _E	L	L _p	Q	v	w	y	Z ⁽¹⁾	θ
mm	2.65	0.3 0.1	2.45 2.25	0.25	0.49 0.36	0.32 0.23	15.6 15.2	7.6 7.4	1.27	10.65 10.00	1.4	1.1 0.4	1.1 1.0	0.25	0.25	0.1	0.9 0.4	8° 0°
inches	0.1	0.012 0.004	0.096 0.089	0.01	0.019 0.014	0.013 0.009	0.61 0.60	0.30 0.29	0.05	0.419 0.394	0.055	0.043 0.016	0.043 0.039	0.01	0.01	0.004	0.035 0.016	

Note

1. Plastic or metal protrusions of 0.15 mm (0.006 inch) maximum per side are not included.

OUTLINE VERSION	REFERENCES			EUROPEAN PROJECTION	ISSUE DATE
	IEC	JEDEC	JEITA		
SOT137-1	075E05	MS-013			99-12-27 03-02-19

Figure 23. Package outline SOT137-1 (SO24)

TSSOP24: plastic thin shrink small outline package; 24 leads; body width 4.4 mm

SOT355-1

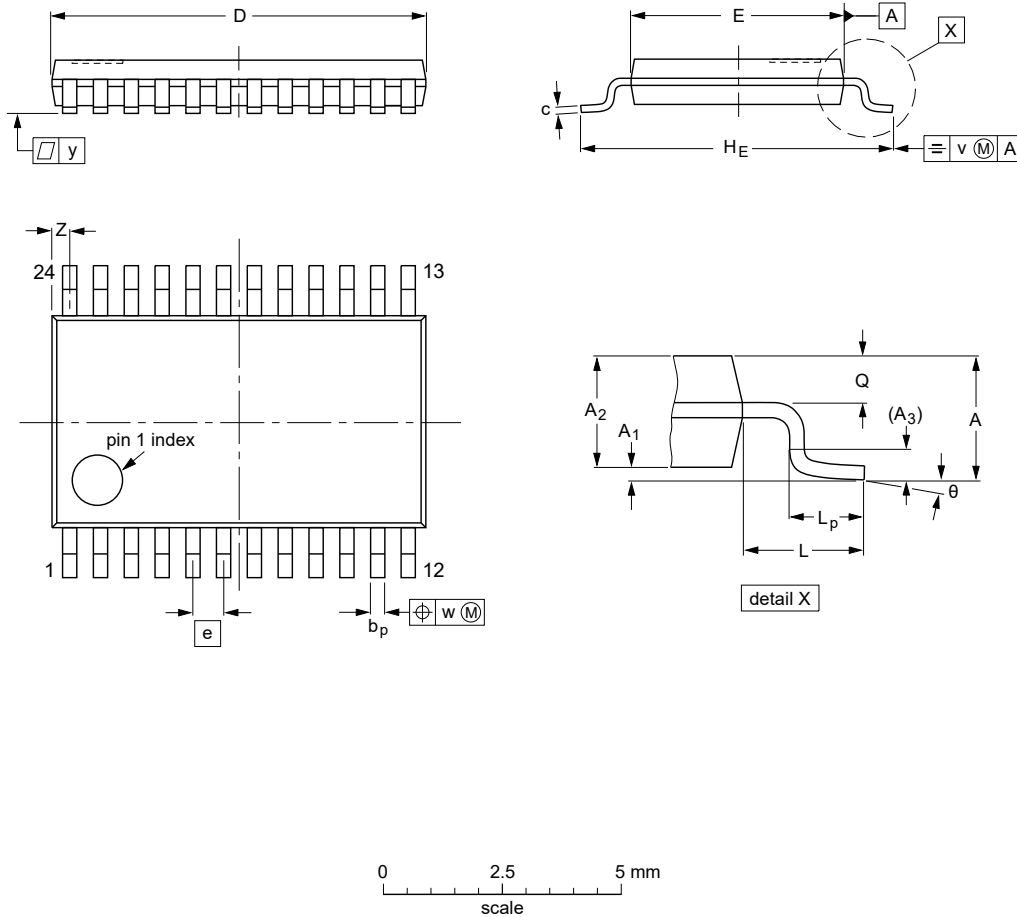

DIMENSIONS (mm are the original dimensions)

UNIT	A max.	A ₁	A ₂	A ₃	b _p	c	D ⁽¹⁾	E ⁽²⁾	e	H _E	L	L _p	Q	v	w	y	Z ⁽¹⁾	θ
mm	1.1	0.15 0.05	0.95 0.80	0.25	0.30 0.19	0.2 0.1	7.9 7.7	4.5 4.3	0.65	6.6 6.2	1	0.75 0.50	0.4 0.3	0.2	0.13	0.1	0.5 0.2	8° 0°

Notes

1. Plastic or metal protrusions of 0.15 mm maximum per side are not included.
2. Plastic interlead protrusions of 0.25 mm maximum per side are not included.

OUTLINE VERSION	REFERENCES				EUROPEAN PROJECTION	ISSUE DATE
	IEC	JEDEC	JEITA			
SOT355-1		MO-153				-99-12-27- 03-02-19

Figure 24. Package outline SOT355-1 (TSSOP24)

HVQFN24: plastic thermal enhanced very thin quad flat package; no leads;
24 terminals; body 4 x 4 x 0.85 mm

SOT616-1

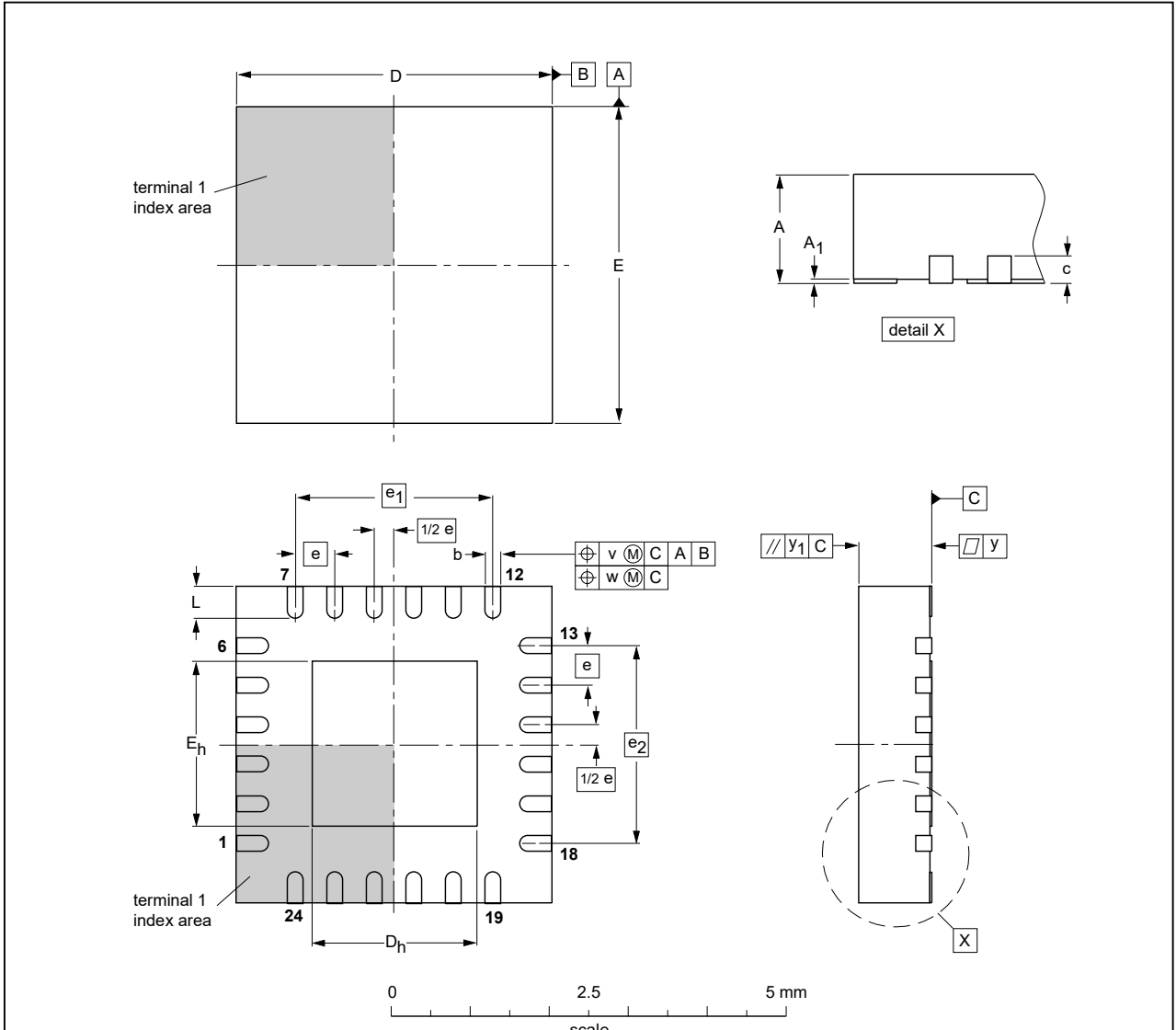

DIMENSIONS (mm are the original dimensions)

UNIT	A ⁽¹⁾ max.	A ₁	b	c	D ⁽¹⁾	D _h	E ⁽¹⁾	E _h	e	e ₁	e ₂	L	v	w	y	y ₁
mm	1	0.05 0.00	0.30 0.18	0.2	4.1 3.9	2.25 1.95	4.1 3.9	2.25 1.95	0.5	2.5	2.5	0.5 0.3	0.1	0.05	0.05	0.1

Note

1. Plastic or metal protrusions of 0.075 mm maximum per side are not included.

OUTLINE VERSION	REFERENCES				EUROPEAN PROJECTION	ISSUE DATE
	IEC	JEDEC	JEITA			
SOT616-1	---	MO-220	---			01-08-08 02-10-22

Figure 25. Package outline SOT616-1 (HVQFN24)

14 Handling information

Inputs and outputs are protected against electrostatic discharge in normal handling. However, to be completely safe you must take normal precautions appropriate to handling integrated circuits.

15 Soldering

This text provides a very brief insight into a complex technology. A more in-depth account of soldering ICs can be found in Application Note AN10365 “Surface mount reflow soldering description”.

15.1 Introduction to soldering

Soldering is one of the most common methods through which packages are attached to Printed Circuit Boards (PCBs), to form electrical circuits. The soldered joint provides both the mechanical and the electrical connection. There is no single soldering method that is ideal for all IC packages. Wave soldering is often preferred when through-hole and Surface Mount Devices (SMDs) are mixed on one printed wiring board; however, it is not suitable for fine pitch SMDs. Reflow soldering is ideal for the small pitches and high densities that come with increased miniaturization.

15.2 Wave and reflow soldering

Wave soldering is a joining technology in which the joints are made by solder coming from a standing wave of liquid solder. The wave soldering process is suitable for the following:

- Through-hole components
- Leaded or leadless SMDs, which are glued to the surface of the printed circuit board

Not all SMDs can be wave soldered. Packages with solder balls, and some leadless packages which have solder lands underneath the body, cannot be wave soldered. Also, leaded SMDs with leads having a pitch smaller than ~0.6 mm cannot be wave soldered, due to an increased probability of bridging.

The reflow soldering process involves applying solder paste to a board, followed by component placement and exposure to a temperature profile. Leaded packages, packages with solder balls, and leadless packages are all reflow solderable.

Key characteristics in both wave and reflow soldering are:

- Board specifications, including the board finish, solder masks and vias
- Package footprints, including solder thieves and orientation
- The moisture sensitivity level of the packages
- Package placement
- Inspection and repair
- Lead-free soldering versus SnPb soldering

15.3 Wave soldering

Key characteristics in wave soldering are:

- Process issues, such as application of adhesive and flux, clinching of leads, board transport, the solder wave parameters, and the time during which components are exposed to the wave
- Solder bath specifications, including temperature and impurities

15.4 Reflow soldering

Key characteristics in reflow soldering are:

- Lead-free versus SnPb soldering; note that a lead-free reflow process usually leads to higher minimum peak temperatures (see [Figure 26](#)) than a SnPb process, thus reducing the process window
- Solder paste printing issues including smearing, release, and adjusting the process window for a mix of large and small components on one board
- Reflow temperature profile; this profile includes preheat, reflow (in which the board is heated to the peak temperature) and cooling down. It is imperative that the peak temperature is high enough for the solder to make reliable solder joints (a solder paste characteristic). In addition, the peak temperature must be low enough that the packages and/or boards are not damaged. The peak temperature of the package depends on package thickness and volume and is classified in accordance with [Table 16](#) and [Table 17](#)

Table 16. SnPb eutectic process (from J-STD-020D)

Package thickness (mm)	Package reflow temperature (°C)	
	Volume (mm ³)	
	< 350	≥ 350
< 2.5	235	220
≥ 2.5	220	220

Table 17. Lead-free process (from J-STD-020D)

Package thickness (mm)	Package reflow temperature (°C)		
	Volume (mm ³)		
	< 350	350 to 2000	> 2000
< 1.6	260	260	260
1.6 to 2.5	260	250	245
> 2.5	250	245	245

Moisture sensitivity precautions, as indicated on the packing, must be respected at all times.

Studies have shown that small packages reach higher temperatures during reflow soldering, see [Figure 26](#).

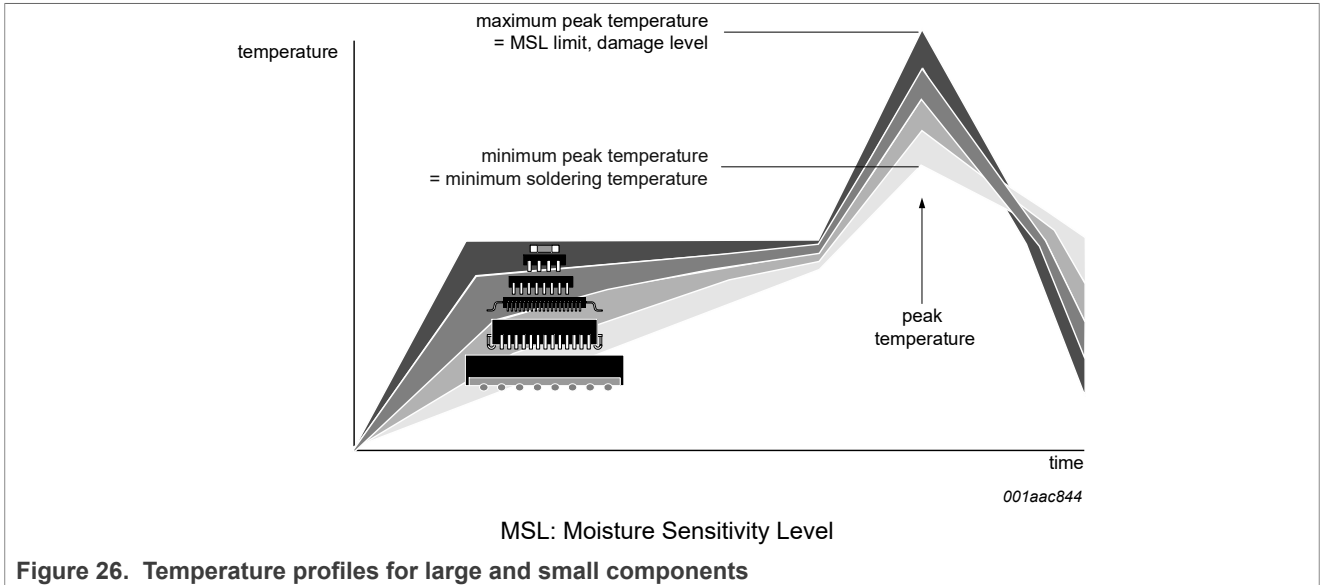

Figure 26. Temperature profiles for large and small components

For further information on temperature profiles, refer to Application Note AN10365 “Surface mount reflow soldering description”.

16 Abbreviations

Table 18. Abbreviations

Acronym	Description
CDM	Charged Device Model
DSP	Digital Signal Processor
ESD	ElectroStatic Discharge
HBM	Human Body Model
GPIO	General Purpose Input/Output
IC	Integrated Circuit
I ² C-bus	Inter IC bus
LED	Light Emitting Diode
MCU	Microcontroller
MM	Machine Model
MPU	Microprocessor
POR	Power-On Reset
PWM	Pulse Width Modulation
SMBus	System Management Bus

17 Revision history

Table 19. Revision history

Document ID	Release date	Data sheet status	Change notice	Supersedes
PCA9552 v5.1	20230525	Product data sheet	-	PCA9552_5
Modifications:	<ul style="list-style-type: none"> The format of this data sheet has been redesigned to comply with the new presentation and information standard of NXP Semiconductors. Replaced deprecated terms 'master' and 'slave' with 'controller' and 'target' respectively to comply with NXPs inclusive language policy 			
PCA9552_5	20060309	Product data sheet	-	PCA9552_4
PCA9552_4	20041001	Product data sheet	-	PCA9552_3
PCA9552_3	20030502	Product data	853-2374 29857 of 2003 Apr 24	PCA9552_2
PCA9552_2	20030224	Product data	853-2374 29331 of 2002 Dec 20	PCA9552_1
PCA9552_1	20020927	Product data	853-2374 28878 of 2002 Sep 09	-

18 Legal information

18.1 Data sheet status

Document status ^{[1][2]}	Product status ^[3]	Definition
Objective [short] data sheet	Development	This document contains data from the objective specification for product development.
Preliminary [short] data sheet	Qualification	This document contains data from the preliminary specification.
Product [short] data sheet	Production	This document contains the product specification.

[1] Please consult the most recently issued document before initiating or completing a design.

[2] The term 'short data sheet' is explained in section "Definitions".

[3] The product status of device(s) described in this document may have changed since this document was published and may differ in case of multiple devices. The latest product status information is available on the Internet at URL <http://www.nxp.com>.

18.2 Definitions

Draft — A draft status on a document indicates that the content is still under internal review and subject to formal approval, which may result in modifications or additions. NXP Semiconductors does not give any representations or warranties as to the accuracy or completeness of information included in a draft version of a document and shall have no liability for the consequences of use of such information.

Short data sheet — A short data sheet is an extract from a full data sheet with the same product type number(s) and title. A short data sheet is intended for quick reference only and should not be relied upon to contain detailed and full information. For detailed and full information see the relevant full data sheet, which is available on request via the local NXP Semiconductors sales office. In case of any inconsistency or conflict with the short data sheet, the full data sheet shall prevail.

Product specification — The information and data provided in a Product data sheet shall define the specification of the product as agreed between NXP Semiconductors and its customer, unless NXP Semiconductors and customer have explicitly agreed otherwise in writing. In no event however, shall an agreement be valid in which the NXP Semiconductors product is deemed to offer functions and qualities beyond those described in the Product data sheet.

18.3 Disclaimers

Limited warranty and liability — Information in this document is believed to be accurate and reliable. However, NXP Semiconductors does not give any representations or warranties, expressed or implied, as to the accuracy or completeness of such information and shall have no liability for the consequences of use of such information. NXP Semiconductors takes no responsibility for the content in this document if provided by an information source outside of NXP Semiconductors.

In no event shall NXP Semiconductors be liable for any indirect, incidental, punitive, special or consequential damages (including - without limitation - lost profits, lost savings, business interruption, costs related to the removal or replacement of any products or rework charges) whether or not such damages are based on tort (including negligence), warranty, breach of contract or any other legal theory.

Notwithstanding any damages that customer might incur for any reason whatsoever, NXP Semiconductors' aggregate and cumulative liability towards customer for the products described herein shall be limited in accordance with the Terms and conditions of commercial sale of NXP Semiconductors.

Right to make changes — NXP Semiconductors reserves the right to make changes to information published in this document, including without limitation specifications and product descriptions, at any time and without notice. This document supersedes and replaces all information supplied prior to the publication hereof.

Suitability for use — NXP Semiconductors products are not designed, authorized or warranted to be suitable for use in life support, life-critical or safety-critical systems or equipment, nor in applications where failure or malfunction of an NXP Semiconductors product can reasonably be expected to result in personal injury, death or severe property or environmental damage. NXP Semiconductors and its suppliers accept no liability for inclusion and/or use of NXP Semiconductors products in such equipment or applications and therefore such inclusion and/or use is at the customer's own risk.

Applications — Applications that are described herein for any of these products are for illustrative purposes only. NXP Semiconductors makes no representation or warranty that such applications will be suitable for the specified use without further testing or modification.

Customers are responsible for the design and operation of their applications and products using NXP Semiconductors products, and NXP Semiconductors accepts no liability for any assistance with applications or customer product design. It is customer's sole responsibility to determine whether the NXP Semiconductors product is suitable and fit for the customer's applications and products planned, as well as for the planned application and use of customer's third party customer(s). Customers should provide appropriate design and operating safeguards to minimize the risks associated with their applications and products.

NXP Semiconductors does not accept any liability related to any default, damage, costs or problem which is based on any weakness or default in the customer's applications or products, or the application or use by customer's third party customer(s). Customer is responsible for doing all necessary testing for the customer's applications and products using NXP Semiconductors products in order to avoid a default of the applications and the products or of the application or use by customer's third party customer(s). NXP does not accept any liability in this respect.

Limiting values — Stress above one or more limiting values (as defined in the Absolute Maximum Ratings System of IEC 60134) will cause permanent damage to the device. Limiting values are stress ratings only and (proper) operation of the device at these or any other conditions above those given in the Recommended operating conditions section (if present) or the Characteristics sections of this document is not warranted. Constant or repeated exposure to limiting values will permanently and irreversibly affect the quality and reliability of the device.

Terms and conditions of commercial sale — NXP Semiconductors products are sold subject to the general terms and conditions of commercial sale, as published at <http://www.nxp.com/profile/terms>, unless otherwise agreed in a valid written individual agreement. In case an individual agreement is concluded only the terms and conditions of the respective agreement shall apply. NXP Semiconductors hereby expressly objects to applying the customer's general terms and conditions with regard to the purchase of NXP Semiconductors products by customer.

No offer to sell or license — Nothing in this document may be interpreted or construed as an offer to sell products that is open for acceptance or the grant, conveyance or implication of any license under any copyrights, patents or other industrial or intellectual property rights.

Quick reference data — The Quick reference data is an extract of the product data given in the Limiting values and Characteristics sections of this document, and as such is not complete, exhaustive or legally binding.

Export control — This document as well as the item(s) described herein may be subject to export control regulations. Export might require a prior authorization from competent authorities.

Suitability for use in non-automotive qualified products — Unless this data sheet expressly states that this specific NXP Semiconductors product is automotive qualified, the product is not suitable for automotive use. It is neither qualified nor tested in accordance with automotive testing or application requirements. NXP Semiconductors accepts no liability for inclusion and/or use of non-automotive qualified products in automotive equipment or applications.

In the event that customer uses the product for design-in and use in automotive applications to automotive specifications and standards, customer (a) shall use the product without NXP Semiconductors' warranty of the product for such automotive applications, use and specifications, and (b) whenever customer uses the product for automotive applications beyond NXP Semiconductors' specifications such use shall be solely at customer's own risk, and (c) customer fully indemnifies NXP Semiconductors for any liability, damages or failed product claims resulting from customer design and use of the product for automotive applications beyond NXP Semiconductors' standard warranty and NXP Semiconductors' product specifications.

Translations — A non-English (translated) version of a document, including the legal information in that document, is for reference only. The English version shall prevail in case of any discrepancy between the translated and English versions.

Security — Customer understands that all NXP products may be subject to unidentified vulnerabilities or may support established security standards or specifications with known limitations. Customer is responsible for the design and operation of its applications and products throughout their lifecycles to reduce the effect of these vulnerabilities on customer's applications and products. Customer's responsibility also extends to other open and/or proprietary technologies supported by NXP products for use in customer's applications. NXP accepts no liability for any vulnerability. Customer should regularly check security updates from NXP and follow up appropriately.

Customer shall select products with security features that best meet rules, regulations, and standards of the intended application and make the ultimate design decisions regarding its products and is solely responsible for compliance with all legal, regulatory, and security related requirements concerning its products, regardless of any information or support that may be provided by NXP.

NXP has a Product Security Incident Response Team (PSIRT) (reachable at PSIRT@nxp.com) that manages the investigation, reporting, and solution release to security vulnerabilities of NXP products.

18.4 Trademarks

Notice: All referenced brands, product names, service names, and trademarks are the property of their respective owners.

NXP — wordmark and logo are trademarks of NXP B.V.

Tables

Tab. 1.	Ordering information	2	Tab. 10.	PWM1 - Pulse Width Modulation 1 register description	7
Tab. 2.	Ordering options	2	Tab. 11.	LS0 to LS3 - LED selector registers bit description	7
Tab. 3.	Pin description	4	Tab. 12.	Programming PCA9552	12
Tab. 4.	Register summary	5	Tab. 13.	Limiting values	13
Tab. 5.	INPUT0 - input register 0 description	6	Tab. 14.	Static characteristics	13
Tab. 6.	INPUT1 - input register 1 description	6	Tab. 15.	Dynamic characteristics	14
Tab. 7.	PSC0 - Frequency Prescaler 0 register description	6	Tab. 16.	SnPb eutectic process (from J-STD-020D)	22
Tab. 8.	PWM0 - Pulse Width Modulation 0 register description	6	Tab. 17.	Lead-free process (from J-STD-020D)	22
Tab. 9.	PSC1 - Frequency Prescaler 1 register description	7	Tab. 18.	Abbreviations	23
			Tab. 19.	Revision history	24

Figures

Fig. 1.	Block diagram of PCA9552	2	Fig. 16.	Device supplied by a lower voltage	12
Fig. 2.	Pin configuration for SO24	3	Fig. 17.	Typical frequency variation over process at VDD = 2.3 V to 3.0 V	14
Fig. 3.	Pin configuration for TSSOP24	3	Fig. 18.	Typical frequency variation over process at VDD = 3.0 V to 5.5 V	14
Fig. 4.	Pin configuration for HVQFN24	3	Fig. 19.	Definition of timing on the I2C-bus	16
Fig. 5.	PCA9552 address	5	Fig. 20.	I2C-bus timing diagram	16
Fig. 6.	Control Register	5	Fig. 21.	Reset timing	16
Fig. 7.	Bit transfer	9	Fig. 22.	Test circuitry for switching times	17
Fig. 8.	Definition of START and STOP conditions	9	Fig. 23.	Package outline SOT137-1 (SO24)	18
Fig. 9.	System configuration	9	Fig. 24.	Package outline SOT355-1 (TSSOP24)	19
Fig. 10.	Acknowledgement on the I2C-bus	10	Fig. 25.	Package outline SOT616-1 (HVQFN24)	20
Fig. 11.	Write to register	10	Fig. 26.	Temperature profiles for large and small components	23
Fig. 12.	Read from register	10			
Fig. 13.	Read Input Port register	11			
Fig. 14.	Typical application	11			
Fig. 15.	High value resistor in parallel with the LED	12			

Contents

1	General description	1
2	Features	1
3	Ordering information	2
3.1	Ordering options	2
4	Block diagram	2
5	Pinning information	3
5.1	Pinning	3
5.2	Pin description	4
6	Functional description	4
6.1	Device address	4
6.2	Control Register	5
6.2.1	Control Register definition	5
6.3	Register descriptions	6
6.3.1	INPUT0 - Input register 0	6
6.3.2	INPUT1 - Input register 1	6
6.3.3	PCS0 - Frequency Prescaler 0	6
6.3.4	PWM0 - Pulse Width Modulation 0	6
6.3.5	PCS1 - Frequency Prescaler 1	7
6.3.6	PWM1 - Pulse Width Modulation 1	7
6.3.7	LS0 to LS3 - LED selector registers	7
6.4	Pins used as GPIOs	8
6.5	Power-on reset	8
6.6	External RESET	8
7	Characteristics of the I2C-bus	8
7.1	Bit transfer	9
7.1.1	START and STOP conditions	9
7.2	System configuration	9
7.3	Acknowledge	9
7.4	Bus transactions	10
8	Application design-in information	11
8.1	Minimizing IDD when the I/O is used to control LEDs	11
8.2	Programming example	12
9	Limiting values	13
10	Static characteristics	13
11	Dynamic characteristics	14
12	Test information	17
13	Package outline	18
14	Handling information	21
15	Soldering	21
15.1	Introduction to soldering	21
15.2	Wave and reflow soldering	21
15.3	Wave soldering	21
15.4	Reflow soldering	22
16	Abbreviations	23
17	Revision history	24
18	Legal information	25

Please be aware that important notices concerning this document and the product(s) described herein, have been included in section 'Legal information'.

Looking for pricing, stock, or lifecycle information?

Click below to explore more details on WIN SOURCE:

 [View PCA9552D,118 on WIN SOURCE](#)

 [NXP / Nexperia Information](#)

Optimize Your Supply Chain with WIN SOURCE Solutions

-  Global Sourcing Solution
-  Obsolete Management
-  Cost Control Management
-  Shortage Management
-  Alternative Solution
-  Excess Inventory Management