

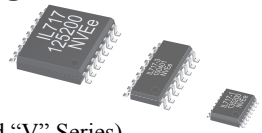

**THE DATASHEET OF
IL717-3E**



High Speed Four-Channel Digital Isolators



Functional Diagrams

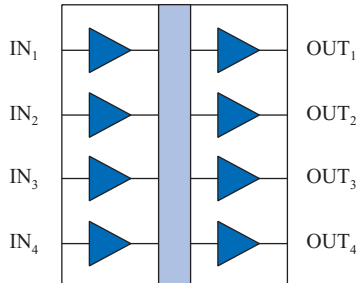

IL715

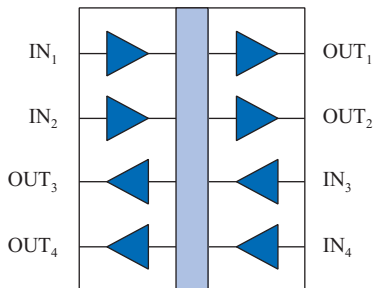

IL716

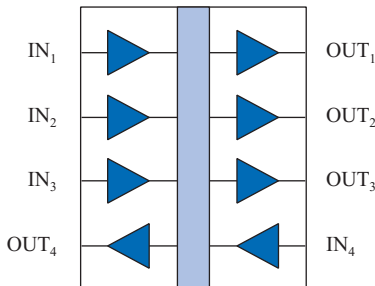

IL717

Features

- High speed: 110 Mbps
- High temperature: -40°C to $+125^{\circ}\text{C}$ (“T” and “V” Series)
- Very high isolation: 6 kV_{RMS} Reinforced Isolation (V-Series)
- High working voltage: 1 kV_{RMS} per VDE V 0884-10 (V-Series)
- 50 kV/ μs typical common mode transient immunity
- No carrier or clock for low EMI emissions and susceptibility
- 1.2 mA/channel typical quiescent current
- 100 ps pulse jitter
- 2 ns channel-to-channel skew
- 10 ns typical propagation delay
- 44000 year barrier life
- Excellent magnetic immunity
- VDE V 0884-10 certified; UL 1577 recognized
- 0.15" and 0.3" True 8TM mm 16-pin SOIC; 16-pin QSOP packages

Applications

- ADCs and DACs
- Digital Fieldbus
- Multiplexed data transmission
- Board-to-board communication
- Ground loop elimination
- Parallel bus
- Logic level shifting
- Equipment covered under IEC 61010-1 Edition 3
- 5 kV_{RMS} rated IEC 60601-1 medical applications

Description

NVE’s IL715, IL716, and IL717 four-channel high-speed digital isolators are CMOS devices manufactured with NVE’s patented* IsoLoop[®] spintronic Giant Magnetoresistive (GMR) technology.

A unique ceramic/polymer composite barrier provides excellent isolation and virtually unlimited barrier life.

All transmit and receive channels operate at 110 Mbps over the full temperature and supply voltage range. The symmetric magnetic coupling barrier provides a typical propagation delay of only 10 ns and a pulse width distortion of 2 ns, achieving the best specifications of any isolator.

Typical transient immunity of 50 kV/ μs is unsurpassed. High channel density makes these devices ideal for isolating ADCs and DACs, parallel buses and peripheral interfaces.

The IL715, IL716, and IL717 are available in 16-pin 0.3" and 0.15" SOIC, and ultraminiature QSOP packages.

Performance is specified over a temperature range of -40°C to $+100^{\circ}\text{C}$. “T” and “V” Series parts have a maximum operating temperature of 125°C .

V-Series versions have an extremely high isolation voltage of 6 kV_{RMS}.

Absolute Maximum Ratings

Parameters	Symbol	Min.	Typ.	Max.	Units	Test Conditions
Storage Temperature	T_S	-55		150	°C	
Junction Temperature	T_J	-55		150	°C	
Ambient Operating Temperature ⁽¹⁾ “T” and “V” Versions	T_A	-40		100 125	°C	
Supply Voltage	V_{DD1}, V_{DD2}	-0.5		7	V	
Input Voltage	V_I	-0.5		$V_{DD}+0.5$	V	
Output Voltage	V_O	-0.5		$V_{DD}+0.5$	V	
Output Current Drive	I_O			10	mA	
Lead Solder Temperature				260	°C	10 sec.
ESD			2		kV	HBM

Recommended Operating Conditions

Parameters	Symbol	Min.	Typ.	Max.	Units	Test Conditions
Ambient Operating Temperature “T” and “V” Versions	T_A	-40		100 125	°C	
Junction Temperature “T” and “V” Versions	T_J	-40		110 125	°C	
Supply Voltage	V_{DD1}, V_{DD2}	3.0		5.5	V	
Logic High Input Voltage	V_{IH}	2.4		V_{DD}	V	
Logic Low Input Voltage	V_{IL}	0		0.8	V	
Input Signal Rise and Fall Times	t_{IR}, t_{IF}			1	μs	

Insulation Specifications

Parameters	Symbol	Min.	Typ.	Max.	Units	Test Conditions
Creepage Distance (external)	QSOP 0.15" SOIC 0.3" SOIC	4.03 4.03 8.03	8.3		mm	Per IEC 60601
Total Barrier Thickness (internal)		0.012	0.016		mm	
Leakage Current ⁽⁵⁾			0.2		μA	240 V_{RMS} , 60 Hz
Barrier Resistance ⁽⁵⁾			$>10^{14}$		Ω	500 V
Barrier Capacitance ⁽⁵⁾			4		pF	f = 1 MHz
Comparative Tracking Index	QSOP 0.15" SOIC 0.3" SOIC	≥175 ≥175 ≥600			V_{RMS}	Per IEC 60112
High Voltage Endurance (Maximum Barrier Voltage for Indefinite Life)	AC DC	1000 1500			V_{RMS} V_{DC}	At maximum operating temperature
Surge Immunity (“V” Versions)	V_{IOSM}	12.8			kV _{PK}	Per IEC 61000-4-5
Barrier Life			44000		Years	100°C, 1000 V_{RMS} , 60% CL activation energy

Thermal Characteristics

Parameter	Symbol	Min.	Typ.	Max.	Units	Test Conditions
Junction–Ambient Thermal Resistance	θ_{JA}		60 60 60		°C/W	Soldered to double-sided board; free air
Junction–Case (Top) Thermal Resistance	Ψ_{JT}		10 10 20		°C/W	
Power Dissipation	P_D			675 700 800	mW	

Safety and Approvals

VDE V 0884-10 (VDE V 0884-11 pending)

V-Series (Reinforced Isolation; VDE File Number 5016933-4880-0002)

- Working Voltage (V_{IORM}) 1000 V_{RMS} (1415 V_{PK}); reinforced insulation; pollution degree 2
- Isolation voltage (V_{ISO}) 6000 V_{RMS}
- Surge immunity (V_{IOSM}) 12.8 k V_{PK}
- Surge rating 8 kV
- Transient overvoltage (V_{IOTM}) 6000 V_{PK}
- Each part tested at 2387 V_{PK} for 1 second, 5 pC partial discharge limit
- Samples tested at 6000 V_{PK} for 60 sec.; then 2122 V_{PK} for 10 sec. with 5 pC partial discharge limit

Standard versions (Basic Isolation; VDE File Number 5016933-4880-0001)

- Working Voltage (V_{IORM}) 600 V_{RMS} (848 V_{PK}); basic insulation; pollution degree 2
- Isolation voltage (V_{ISO}) 2500 V_{RMS}
- Transient overvoltage (V_{IOTM}) 4000 V_{PK}
- Surge rating 4000 V
- Each part tested at 1590 V_{PK} for 1 second, 5 pC partial discharge limit
- Samples tested at 4000 V_{PK} for 60 sec.; then 1358 V_{PK} for 10 sec. with 5 pC partial discharge limit

Safety-Limiting Values	Symbol	Value	Units
Safety rating ambient temperature	T_S	180	$^{\circ}C$
Safety rating power (180 $^{\circ}C$)	P_S	270	mW
Supply current safety rating (total of supplies)	I_S	54	mA

IEC 61010-1 (Edition 2; TUV Certificate Numbers N1502812; N1502812-101)

Reinforced Insulation; Pollution Degree II; Material Group III

Part No. Suffix	Package	Working Voltage
-1	QSOP	300 V_{RMS}
-3	0.15" SOIC	300 V_{RMS}
None	0.3" SOIC (standard)	300 V_{RMS}
V	0.3" SOIC (high isolation voltage)	1000 V_{RMS}

UL 1577 (Component Recognition Program File Number E207481)

- 6 kV-rated V-Series parts tested at 7.2 k V_{RMS} (10.2 k V_{PK}) for 1 second; each lot sample tested at 6 k V_{RMS} (8485 V_{PK}) for 1 minute
- 2.5 kV-rated parts tested at 3000 V_{RMS} (4240 V_{PK}) for 1 second; each lot sample tested at 2500 V_{RMS} (3530 V_{PK}) for 1 minute

Soldering Profile

Per JEDEC J-STD-020C, MSL 1

IL715 Pin Connections

1	V _{DD1}	Supply voltage
2	GND ₁	Ground return for V _{DD1} *
3	IN ₁	Data in, channel 1
4	IN ₂	Data in, channel 2
5	IN ₃	Data in, channel 3
6	IN ₄	Data in, channel 4
7	NC	No connection
8	GND ₁	Ground return for V _{DD1} *
9	GND ₂	Ground return for V _{DD2} *
10	NC	No connection
11	OUT ₄	Data out, channel 4
12	OUT ₃	Data out, channel 3
13	OUT ₂	Data out, channel 2
14	OUT ₁	Data out, channel 1
15	GND ₂	Ground return for V _{DD2} *
16	V _{DD2}	Supply voltage

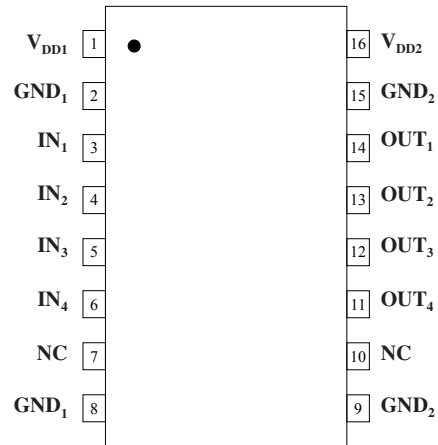

IL715

IL716 Pin Connections

1	V _{DD1}	Supply voltage
2	GND ₁	Ground Return for V _{DD1} *
3	IN ₁	Data in, channel 1
4	IN ₂	Data in, channel 2
5	OUT ₃	Data out, channel 3
6	OUT ₄	Data out, channel 4
7	NC	No connection
8	GND ₁	Ground Return for V _{DD1} *
9	GND ₂	Ground Return for V _{DD2} *
10	NC	No connection
11	IN ₄	Data in, channel 4
12	IN ₃	Data in, channel 3
13	OUT ₂	Data out, channel 2
14	OUT ₁	Data out, channel 1
15	GND ₂	Ground Return for V _{DD2} *
16	V _{DD2}	Supply voltage

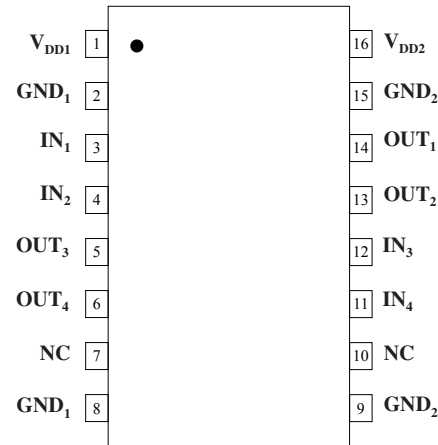

IL716

*NOTE: Pins 2 and 8 are internally connected, as are pins 9 and 15.

IL717 Pin Connections

1	V _{DD1}	Supply voltage
2	GND ₁	Ground return for V _{DD1} *
3	IN ₁	Data in, channel 1
4	IN ₂	Data in, channel 2
5	IN ₃	Data in, channel 3
6	OUT ₄	Data out, channel 4
7	NC	No connection
8	GND ₁	Ground return for V _{DD1} *
9	GND ₂	Ground return for V _{DD2} *
10	NC	No connection
11	IN ₄	Data in, channel 4
12	OUT ₃	Data out, channel 3
13	OUT ₂	Data out, channel 2
14	OUT ₁	Data out, channel 1
15	GND ₂	Ground return for V _{DD2} *
16	V _{DD2}	Supply voltage

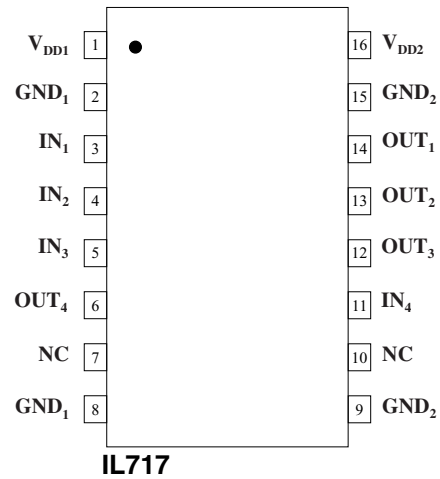

*NOTE: Pins 2 and 8 are internally connected, as are pins 9 and 15.

Timing Diagram

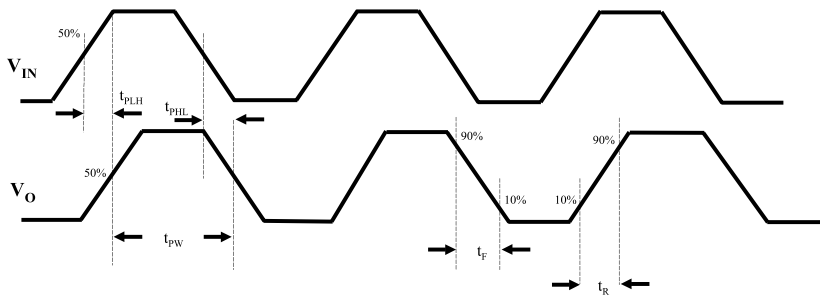

Legend

t _{PLH}	Propagation Delay, Low to High
t _{PHL}	Propagation Delay, High to Low
t _{PW}	Minimum Pulse Width
t _R	Rise Time
t _F	Fall Time

3.3 Volt Electrical Specifications (T_{min} to T_{max} unless otherwise stated)						
Parameters	Symbol	Min.	Typ.	Max.	Units	Test Conditions
Input Quiescent Supply Current						
IL715 and IL715-3	I_{DD1}		16	20	μA	
IL715-1			300	400	μA	
IL716			2.4	3.5	mA	
IL717			1.2	1.75	mA	
Output Quiescent Supply Current						
IL715	I_{DD2}		4.8	7	mA	
IL716			2.4	3.5	mA	
IL717			3.6	5.25	mA	
Logic Input Current	I_I	-10		10	μA	
Logic High Output Voltage	V_{OH}	$V_{DD} - 0.1$ $0.8 \times V_{DD}$	V_{DD} $0.9 \times V_{DD}$		V	$I_O = -20 \mu A, V_I = V_{IH}$ $I_O = -4 mA, V_I = V_{IH}$
Logic Low Output Voltage	V_{OL}		0 0.5	0.1 0.8	V	$I_O = 20 \mu A, V_I = V_{IL}$ $I_O = 4 mA, V_I = V_{IL}$

Switching Specifications ($V_{DD} = 3.3 V$)						
Maximum Data Rate		100	110		Mbps	$C_L = 15 pF$
Pulse Width ⁽⁷⁾	PW	10			ns	50% Points, V_o
Propagation Delay Input to Output (High to Low)	t_{PHL}		12	18	ns	$C_L = 15 pF$
Propagation Delay Input to Output (Low to High)	t_{PLH}		12	18	ns	$C_L = 15 pF$
Pulse Width Distortion ⁽²⁾	PWD		2	3	ns	$C_L = 15 pF$
Propagation Delay Skew ⁽³⁾	t_{PSK}		4	6	ns	$C_L = 15 pF$
Output Rise Time (10%–90%)	t_R		2	4	ns	$C_L = 15 pF$
Output Fall Time (10%–90%)	t_F		2	4	ns	$C_L = 15 pF$
Common Mode Transient Immunity (Output Logic High or Logic Low) ⁽⁴⁾	$ CM_{IH} , CM_{IL} $	30	50		kV/ μs	$V_{CM} = 1500 V_{DC}$ $t_{TRANSIENT} = 25 ns$
Channel-to-Channel Skew	t_{CSK}		2	3	ns	$C_L = 15 pF$
Dynamic Power Consumption ⁽⁶⁾			140	240	$\mu A/Mbps$	per channel

Magnetic Field Immunity ⁽⁸⁾ ($V_{DD2} = 3V, 3V < V_{DD1} < 5.5V$)						
Power Frequency Magnetic Immunity	H_{PF}	1000	1500		A/m	50Hz/60Hz
Pulse Magnetic Field Immunity	H_{PM}	1800	2000		A/m	$t_p = 8 \mu s$
Damped Oscillatory Magnetic Field	H_{OSC}	1800	2000		A/m	0.1Hz – 1MHz
Cross-axis Immunity Multiplier ⁽⁹⁾	K_X		2.5			

5 Volt Electrical Specifications (T_{min} to T_{max} unless otherwise stated)						
Parameters	Symbol	Min.	Typ.	Max.	Units	Test Conditions
Input Quiescent Supply Current						
IL715 and IL715-3	I_{DD1}		24	30	μA	
IL715-1			350	500	μA	
IL716			3.6	5	mA	
IL717			1.8	2.5	mA	
Output Quiescent Supply Current						
IL715	I_{DD2}		7.2	10	mA	
IL716			3.6	5	mA	
IL717			5.4	7.5	mA	
Logic Input Current	I_I	-10		10	μA	
Logic High Output Voltage	V_{OH}	$V_{DD} - 0.1$ $0.8 \times V_{DD}$	V_{DD} $0.9 \times V_{DD}$		V	$I_O = -20 \mu\text{A}, V_I = V_{IH}$ $I_O = -4 \text{mA}, V_I = V_{IH}$
Logic Low Output Voltage	V_{OL}		0 0.5	0.1 0.8	V	$I_O = 20 \mu\text{A}, V_I = V_{IL}$ $I_O = 4 \text{mA}, V_I = V_{IL}$

Switching Specifications ($V_{DD} = 5\text{V}$)						
Maximum Data Rate		100	110		Mbps	$C_L = 15 \text{pF}$
Pulse Width ⁽⁷⁾	PW	10			ns	50% Points, V_o
Propagation Delay Input to Output (High to Low)	t_{PHL}		10	15	ns	$C_L = 15 \text{pF}$
Propagation Delay Input to Output (Low to High)	t_{PLH}		10	15	ns	$C_L = 15 \text{pF}$
Pulse Width Distortion ⁽²⁾	PWD		2	3		$C_L = 15 \text{pF}$
Pulse Jitter ⁽¹⁰⁾	t_j		100		ps	$C_L = 15 \text{pF}$
Propagation Delay Skew ⁽³⁾	t_{PSK}		4	6	ns	$C_L = 15 \text{pF}$
Output Rise Time (10%–90%)	t_R		1	3	ns	$C_L = 15 \text{pF}$
Output Fall Time (10%–90%)	t_F		1	3	ns	$C_L = 15 \text{pF}$
Common Mode Transient Immunity (Output Logic High or Logic Low) ⁽⁴⁾	$ CM_H , CM_L$	30	50		$\text{kV}/\mu\text{s}$	$V_{CM} = 1500 V_{DC}$ $t_{TRANSIENT} = 25 \text{ns}$
Channel-to-Channel Skew	t_{CSK}		2	3	ns	$C_L = 15 \text{pF}$
Dynamic Power Consumption ⁽⁶⁾			200	340	$\mu\text{A}/\text{Mbps}$	per channel

Magnetic Field Immunity ⁽⁸⁾ ($V_{DD2} = 5\text{V}, 3\text{V} < V_{DD1} < 5.5\text{V}$)						
Power Frequency Magnetic Immunity	H_{PF}	2800	3500		A/m	50Hz/60Hz
Pulse Magnetic Field Immunity	H_{PM}	4000	4500		A/m	$t_p = 8\mu\text{s}$
Damped Oscillatory Magnetic Field	H_{OSC}	4000	4500		A/m	0.1Hz – 1MHz
Cross-axis Immunity Multiplier ⁽⁹⁾	K_X		2.5			

Notes (apply to both 3.3 V and 5 V specifications):

- Absolute maximum ambient operating temperature means the device will not be damaged if operated under these conditions. It does not guarantee performance.
- PWD is defined as $|t_{PHL} - t_{PLH}|$. %PWD is equal to PWD divided by pulse width.
- t_{PSK} is the magnitude of the worst-case difference in t_{PHL} and/or t_{PLH} between devices at 25°C.
- CM_H is the maximum common mode voltage slew rate that can be sustained while maintaining $V_o > 0.8 V_{DD2}$. CM_L is the maximum common mode input voltage that can be sustained while maintaining $V_o < 0.8 \text{V}$. The common mode voltage slew rates apply to both rising and falling common mode voltage edges.
- Device is considered a two terminal device: pins 1–8 shorted and pins 9–16 shorted.
- Dynamic power consumption is calculated per channel and is supplied by the channel's input side power supply.
- Minimum pulse width is the minimum value at which specified PWD is guaranteed.
- The relevant test and measurement methods are given in the Electromagnetic Compatibility section on p. 7.
- External magnetic field immunity is improved by this factor if the field direction is "end-to-end" rather than to "pin-to-pin" (see diagram on p. 7).
- 66,535-bit pseudo-random binary signal (PRBS) NRZ bit pattern with no more than five consecutive 1s or 0s; 800 ps transition time.

Application Information

Electrostatic Discharge Sensitivity

This product has been tested for electrostatic sensitivity to the limits stated in the specifications. However, NVE recommends that all integrated circuits be handled with appropriate care to avoid damage. Damage caused by inappropriate handling or storage could range from performance degradation to complete failure.

Electromagnetic Compatibility

IsoLoop Isolators have the lowest EMC footprint of any isolation technology. IsoLoop Isolators' Wheatstone bridge configuration and differential magnetic field signaling ensure excellent EMC performance against all relevant standards.

These isolators are fully compliant with generic EMC standards EN50081, EN50082-1 and the umbrella line-voltage standard for Information Technology Equipment (ITE) EN61000. NVE has completed compliance tests in the categories below:

EN50081-1

Residential, Commercial & Light Industrial
Methods EN55022, EN55014

EN50082-2: Industrial Environment

Methods EN61000-4-2 (ESD), EN61000-4-3 (Electromagnetic Field Immunity), EN61000-4-4 (Electrical Transient Immunity), EN61000-4-6 (RFI Immunity), EN61000-4-8 (Power Frequency Magnetic Field Immunity), EN61000-4-9 (Pulsed Magnetic Field), EN61000-4-10 (Damped Oscillatory Magnetic Field)

ENV50204

Radiated Field from Digital Telephones (Immunity Test)

Immunity to external magnetic fields is even higher if the field direction is "end-to-end" rather than to "pin-to-pin" as shown in the diagram below:

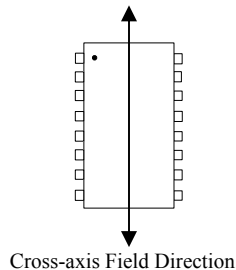

Dynamic Power Consumption

IsoLoop Isolators achieve their low power consumption from the way they transmit data across the isolation barrier. By detecting the edge transitions of the input logic signal and converting these to narrow current pulses, a magnetic field is created around the GMR Wheatstone bridge. Depending on the direction of the magnetic field, the bridge causes the output comparator to switch following the input logic signal. Since the current pulses are narrow, about 2.5 ns, the power consumption is independent of mark-to-space ratio and solely dependent on frequency. This has obvious advantages over optocouplers, which have power consumption heavily dependent on mark-to-space ratio.

Thermal Management

IsoLoop Isolators are designed for low power dissipation and thermal performance, providing unmatched channel density for high-performance isolators. Nevertheless, package temperature rise should be considered when running multiple channels at high speed. Power consumption is higher at 5 volt operation than at 3.3 volts, and dynamic supply current is higher on the input side of the isolators than the output side, so thermal management is more important with five-volt input-side power supplies.

Based on the specifications contained in this datasheet, the derating curve at typical operating conditions is as follows:

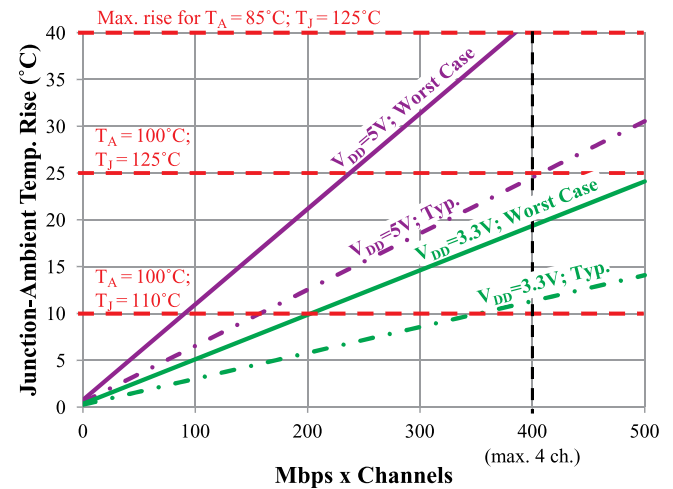

Standard-grade parts have a maximum junction temperature of 110°C. T-Series parts have a maximum operating junction temperature of 125°C for additional margin at extreme operating conditions.

Power Supply Decoupling

Both power supplies to these devices should be decoupled with low ESR 47 nF ceramic capacitors. Ground planes for both GND₁ and GND₂ are highly recommended for data rates above 10 Mbps. Capacitors must be located as close as possible to the V_{DD} pins.

Maintaining Creepage

Creepage distances are often critical in isolated circuits. In addition to meeting JEDEC standards, NVE isolator packages have unique creepage specifications. Standard pad libraries often extend under the package, compromising creepage and clearance. Similarly, ground planes, if used, should be spaced to avoid compromising clearance. Package drawings and recommended pad layouts are included in this datasheet.

Signal Status on Start-up and Shut Down

To minimize power dissipation, input signals are differentiated and then latched on the output side of the isolation barrier to reconstruct the signal. This could result in an ambiguous output state depending on power up, shutdown and power loss sequencing. Therefore, the designer should consider including an initialization signal in the start-up circuit. Initialization consists of toggling the input either high then low, or low then high.

Application Diagrams

Isolated Logic Level Shifters

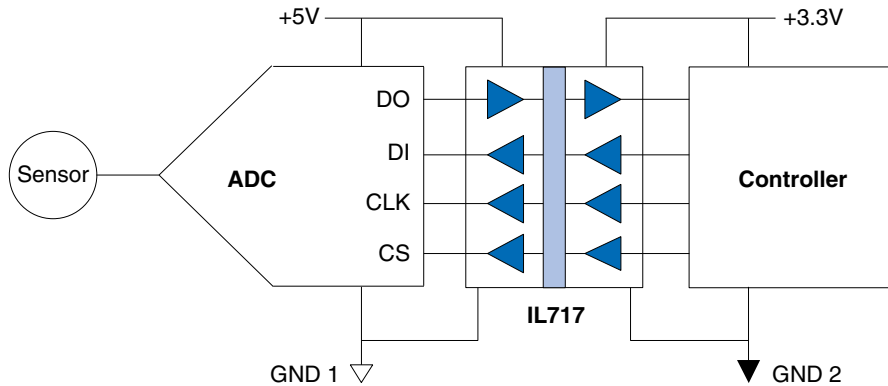

Single-Channel Isolated Delta-Sigma A/D Converter

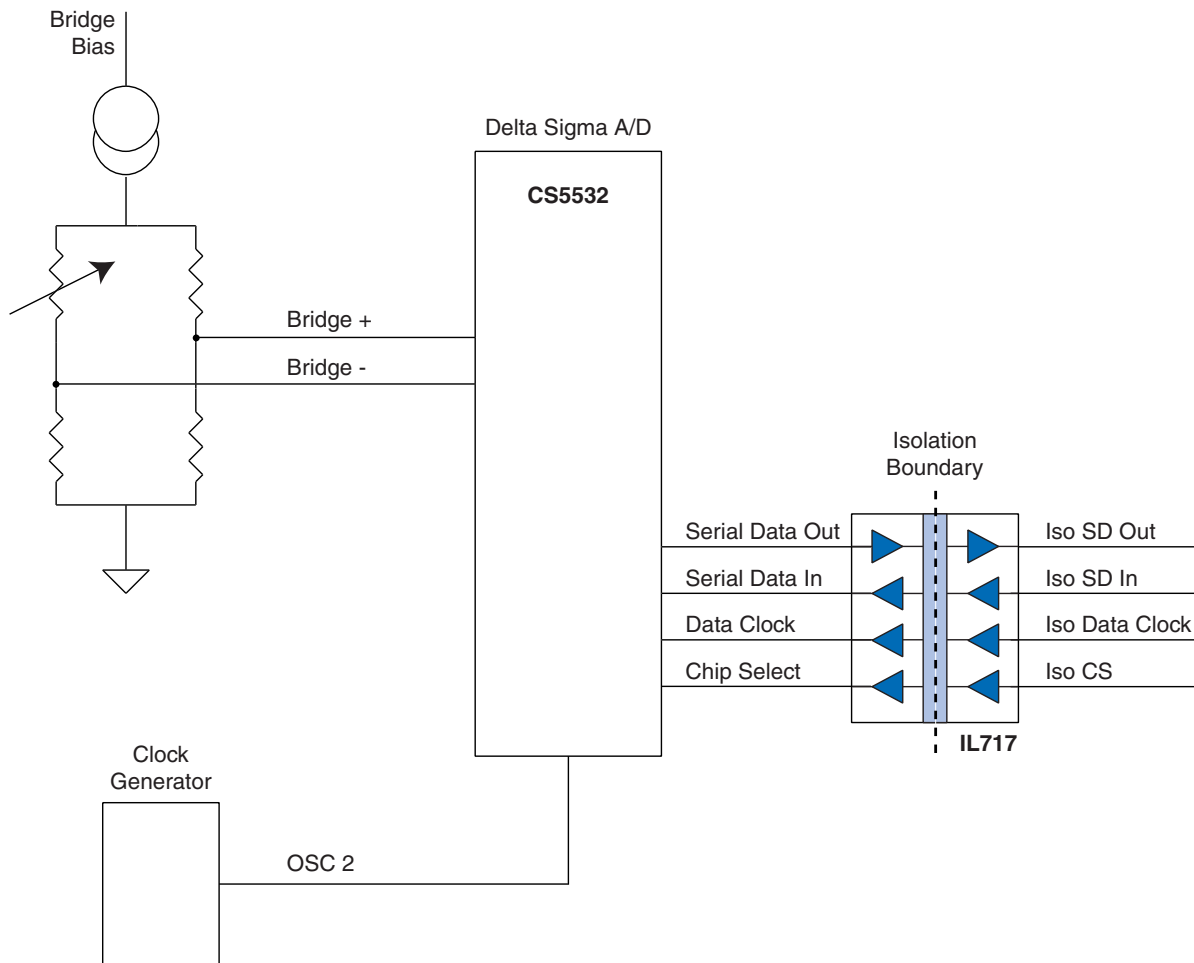

This circuit illustrates a typical single-channel delta-sigma ADC. The A/D is located on the bridge with no signal conditioning electronics between the bridge sensor and the ADC. In this case, the IL717 is the best choice for isolation. It isolates the control bus from the microcontroller. The system clock is located on the isolated side of the system.

Package Drawings

Ultraminiature 16-pin QSOP Package (-1 suffix)

Dimensions in inches (mm); scale = approx. 5X

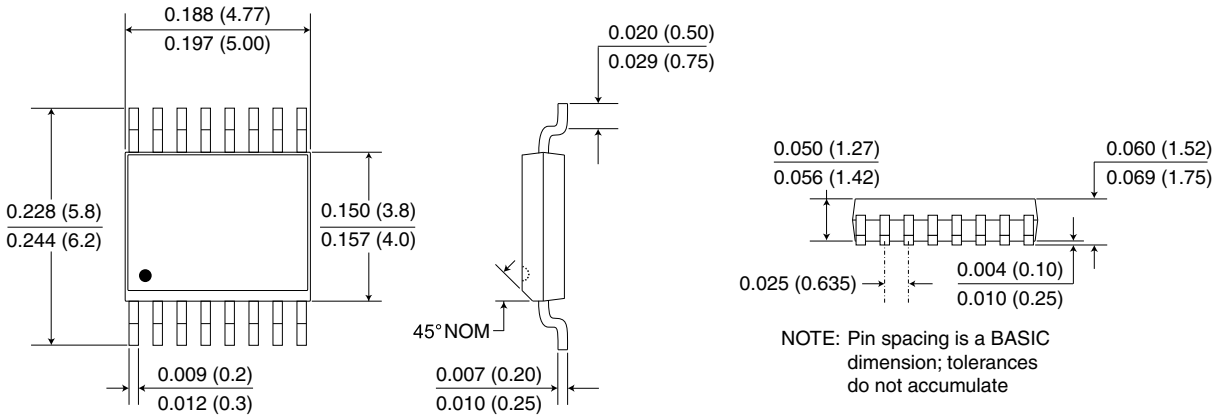

0.15" 16-pin SOIC Package (-3 suffix)

Dimensions in inches (mm); scale = approx. 5X

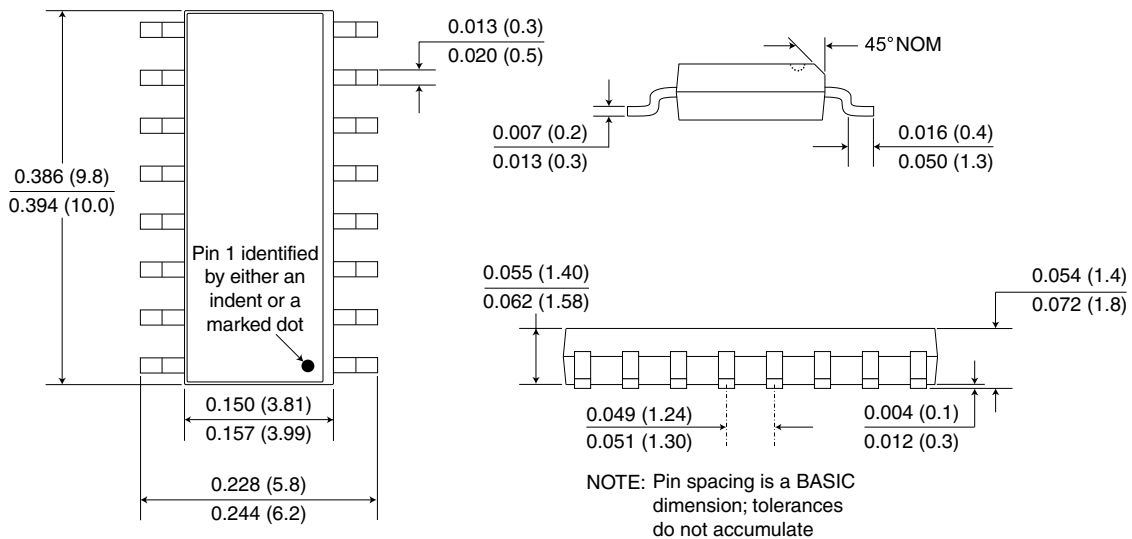

0.3" 16-pin SOIC Package (no suffix)

Dimensions in inches (mm); scale = approx. 5X

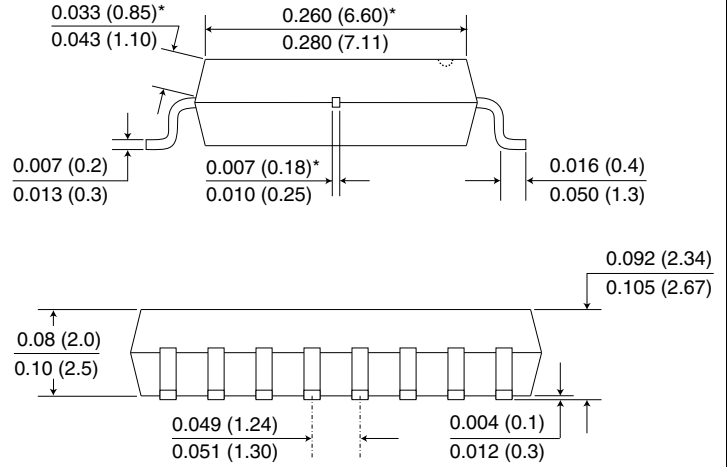
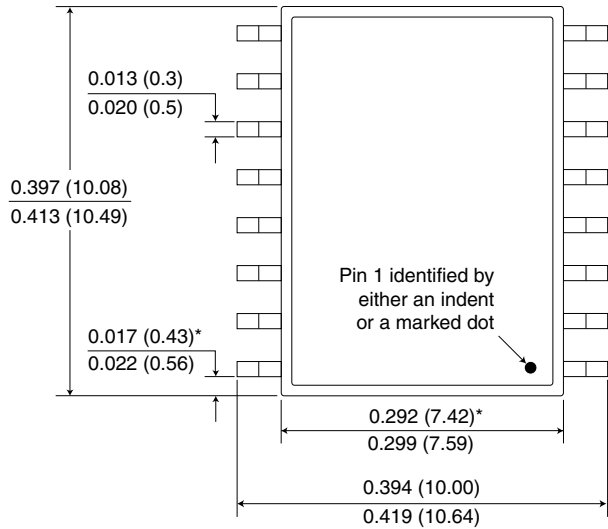

NOTE: Pin spacing is a BASIC dimension; tolerances do not accumulate

*Specified for True 8™ package to guarantee 8 mm creepage per IEC 60601.

Recommended Pad Layouts

4 mm x 5 mm 16-pin QSOP Pad Layout

Dimensions in inches (mm); scale = approx. 5X

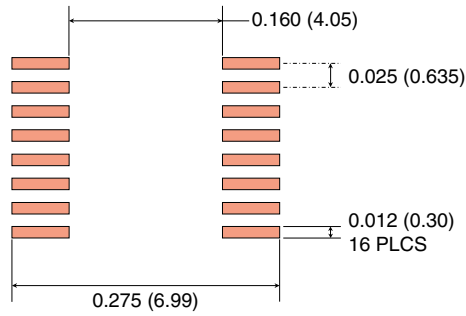

0.15" 16-pin SOIC Pad Layout

Dimensions in inches (mm); scale = approx. 5X

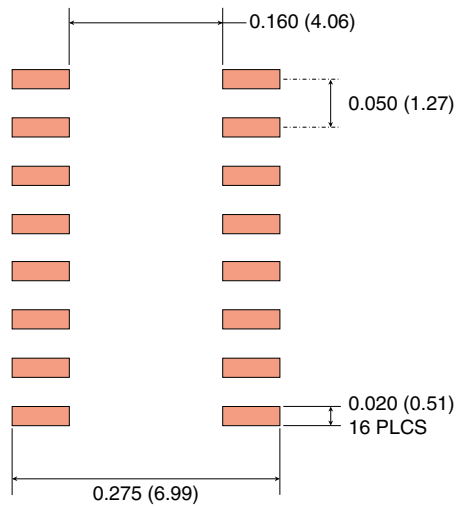

0.3" 16-pin SOIC Pad Layout

Dimensions in inches (mm); scale = approx. 5X

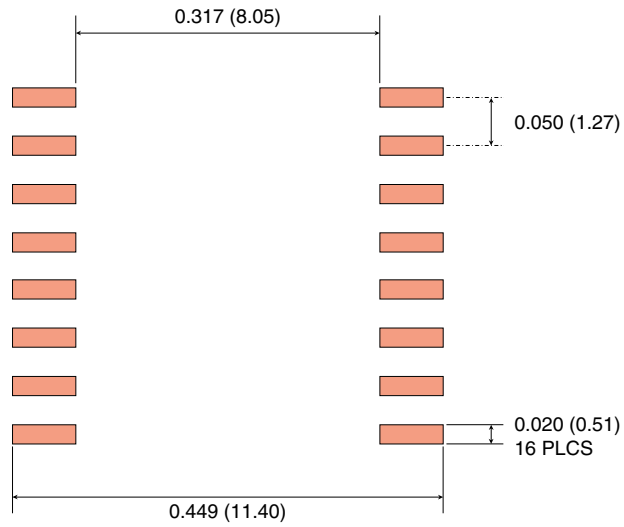

Ordering Information

IL 716 T - 3 E TR13

Valid Part Numbers

IL715	IL716	IL717
IL715E	IL716E	IL717E
IL715-1E	IL716-1E	IL716-1E
IL715-3	IL716-3	IL717-3
IL715-3E	IL716-3E	IL717-3E
IL715T	IL716T	IL717T
IL715TE	IL716TE	IL717TE
IL715T-3	IL716T-3	IL717T-3
IL715T-3E	IL716T-3E	IL717T-3E
IL715VE	IL716VE	IL717VE

All part types are available on tape and reel.

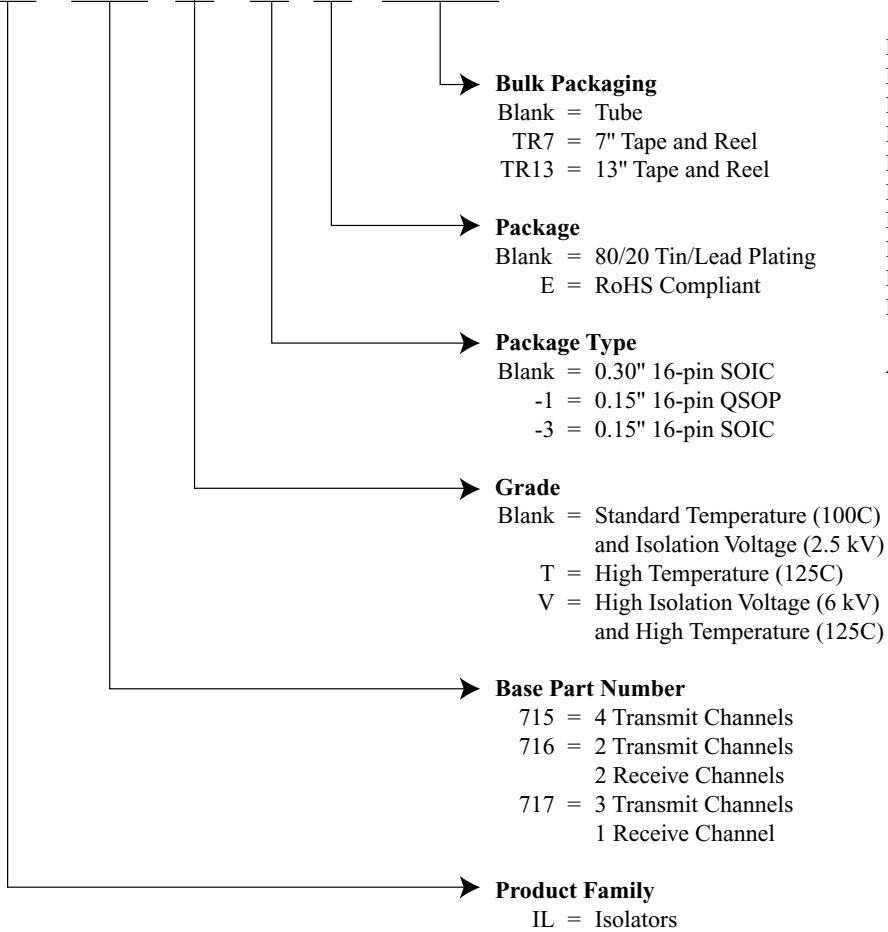

Available Parts

Available Parts	Transmit Channels	Receive Channels	Maximum Temperature	Isolation Voltage (RMS)	Package	RoHS
IL715-1E	4	0	100°C	2.5 kV	QSOP	Y
IL715-3	4	0	100°C	2.5 kV	Narrow SOIC	N
IL715-3E	4	0	100°C	2.5 kV	Narrow SOIC	Y
IL715	4	0	100°C	2.5 kV	Wide SOIC	N
IL715E	4	0	100°C	2.5 kV	Wide SOIC	Y
IL715T-3	4	0	125°C	2.5 kV	Narrow SOIC	N
IL715T-3E	4	0	125°C	2.5 kV	Narrow SOIC	Y
IL715T	4	0	125°C	2.5 kV	Wide SOIC	Y
IL715TE	4	0	125°C	2.5 kV	Wide SOIC	N
IL715VE	4	0	125°C	6 kV	Wide SOIC	Y
IL716-1E	2	2	100°C	2.5 kV	QSOP	N
IL716-3	2	2	100°C	2.5 kV	Narrow SOIC	N
IL716-3E	2	2	100°C	2.5 kV	Narrow SOIC	Y
IL716	2	2	100°C	2.5 kV	Wide SOIC	N
IL716E	2	2	100°C	2.5 kV	Wide SOIC	Y
IL716T-3	2	2	125°C	2.5 kV	Narrow SOIC	N
IL716T-3E	2	2	125°C	2.5 kV	Narrow SOIC	Y
IL716T	2	2	125°C	2.5 kV	Wide SOIC	N
IL716TE	2	2	125°C	2.5 kV	Wide SOIC	Y
IL716VE	2	2	125°C	6 kV	Wide SOIC	Y
IL717-1E	3	1	100°C	2.5 kV	QSOP	Y
IL717-3	3	1	100°C	2.5 kV	Narrow SOIC	N
IL717-3E	3	1	100°C	2.5 kV	Narrow SOIC	Y
IL717	3	1	100°C	2.5 kV	Wide SOIC	N
IL717E	3	1	100°C	2.5 kV	Wide SOIC	Y
IL717T-3	3	1	125°C	2.5 kV	Narrow SOIC	N
IL717T-3E	3	1	125°C	2.5 kV	Narrow SOIC	Y
IL717T	3	1	125°C	2.5 kV	Wide SOIC	N
IL717TE	3	1	125°C	2.5 kV	Wide SOIC	Y
IL717VE	3	1	125°C	6 kV	Wide SOIC	Y

All part types are available on tape and reel.

ISB-DS-001-IL715/6/7-AE
November 2016

Changes

- Updated VDE Reinforced Isolation file number and description.

ISB-DS-001-IL715/6/7-AD

Changes

- Clarified 600 V CTI specification is for 0.3" SOIC only (p. 2).
- Corrected typographical error in “Available Parts” table (p. 15).

ISB-DS-001-IL715/6/7-AC

Changes

- Updated VDE certification standard to VDE V 0884-10.
- Upgraded “V” Version Surge Immunity specification to 12.8 kV.
- Upgraded “V” Version VDE 0884-10 rating to reinforced insulation.
- Corrected QSOP pin width dimension (p. 10).

ISB-DS-001-IL715/6/7-AB

Changes

- Increased V-Series isolation voltage to 6 kVrms.
- Increased typ. Total Barrier Thickness specification to 0.016 mm.
- Increased CTI min. specification to ≥ 600 Vrms.

ISB-DS-001-IL715/6/7-AA

Changes

- Added V-Series 5 kV isolation voltage versions.
- More detailed “Available Parts” table.

ISB-DS-001-IL715/6/7-Z

Changes

- Added package illustrations on first page.
- Added QSOP packages (-1 suffix).
- Revised and added details to thermal characteristic specifications (p. 2).
- Added VDE 0884 Safety-Limiting Values (p. 3).
- Added “Thermal Management” paragraph in Applications section.

ISB-DS-001-IL715/6/7-Y

Changes

- IEC 60747-5-5 (VDE 0884) certification.

ISB-DS-001-IL715/6/7-X

Changes

- Tighter quiescent current specifications.
- Upgraded from MSL 2 to MSL 1.

ISB-DS-001-IL715/6/7-W

Changes

- Increased transient immunity specifications based on additional data.
- Added VDE 0884 pending.
- Added high voltage endurance specification.
- Increased magnetic immunity specifications.
- Updated package drawings.
- Added recommended solder pad layouts.

ISB-DS-001-IL715/6/7-V

Changes

- Detailed isolation and barrier specifications.
- Cosmetic changes.

ISB-DS-001-IL715/6/7-U

Changes

- Tightened typical output quiescent supply spec. to 1.5 mA/channel at 3.3V.

Datasheet Limitations

The information and data provided in datasheets shall define the specification of the product as agreed between NVE and its customer, unless NVE and customer have explicitly agreed otherwise in writing. All specifications are based on NVE test protocols. In no event however, shall an agreement be valid in which the NVE product is deemed to offer functions and qualities beyond those described in the datasheet.

Limited Warranty and Liability

Information in this document is believed to be accurate and reliable. However, NVE does not give any representations or warranties, expressed or implied, as to the accuracy or completeness of such information and shall have no liability for the consequences of use of such information.

In no event shall NVE be liable for any indirect, incidental, punitive, special or consequential damages (including, without limitation, lost profits, lost savings, business interruption, costs related to the removal or replacement of any products or rework charges) whether or not such damages are based on tort (including negligence), warranty, breach of contract or any other legal theory.

Right to Make Changes

NVE reserves the right to make changes to information published in this document including, without limitation, specifications and product descriptions at any time and without notice. This document supersedes and replaces all information supplied prior to its publication.

Use in Life-Critical or Safety-Critical Applications

Unless NVE and a customer explicitly agree otherwise in writing, NVE products are not designed, authorized or warranted to be suitable for use in life support, life-critical or safety-critical devices or equipment. NVE accepts no liability for inclusion or use of NVE products in such applications and such inclusion or use is at the customer's own risk. Should the customer use NVE products for such application whether authorized by NVE or not, the customer shall indemnify and hold NVE harmless against all claims and damages.

Applications

Applications described in this datasheet are illustrative only. NVE makes no representation or warranty that such applications will be suitable for the specified use without further testing or modification.

Customers are responsible for the design and operation of their applications and products using NVE products, and NVE accepts no liability for any assistance with applications or customer product design. It is customer's sole responsibility to determine whether the NVE product is suitable and fit for the customer's applications and products planned, as well as for the planned application and use of customer's third party customers. Customers should provide appropriate design and operating safeguards to minimize the risks associated with their applications and products.

NVE does not accept any liability related to any default, damage, costs or problem which is based on any weakness or default in the customer's applications or products, or the application or use by customer's third party customers. The customer is responsible for all necessary testing for the customer's applications and products using NVE products in order to avoid a default of the applications and the products or of the application or use by customer's third party customers. NVE accepts no liability in this respect.

Limiting Values

Stress above one or more limiting values (as defined in the Absolute Maximum Ratings System of IEC 60134) will cause permanent damage to the device. Limiting values are stress ratings only and operation of the device at these or any other conditions above those given in the recommended operating conditions of the datasheet is not warranted. Constant or repeated exposure to limiting values will permanently and irreversibly affect the quality and reliability of the device.

Terms and Conditions of Sale

In case an individual agreement is concluded only the terms and conditions of the respective agreement shall apply. NVE hereby expressly objects to applying the customer's general terms and conditions with regard to the purchase of NVE products by customer.

No Offer to Sell or License

Nothing in this document may be interpreted or construed as an offer to sell products that is open for acceptance or the grant, conveyance or implication of any license under any copyrights, patents or other industrial or intellectual property rights.

Export Control

This document as well as the items described herein may be subject to export control regulations. Export might require a prior authorization from national authorities.

Automotive Qualified Products

Unless the datasheet expressly states that a specific NVE product is automotive qualified, the product is not suitable for automotive use. It is neither qualified nor tested in accordance with automotive testing or application requirements. NVE accepts no liability for inclusion or use of non-automotive qualified products in automotive equipment or applications.

In the event that customer uses the product for design-in and use in automotive applications to automotive specifications and standards, customer (a) shall use the product without NVE's warranty of the product for such automotive applications, use and specifications, and (b) whenever customer uses the product for automotive applications beyond NVE's specifications such use shall be solely at customer's own risk, and (c) customer fully indemnifies NVE for any liability, damages or failed product claims resulting from customer design and use of the product for automotive applications beyond NVE's standard warranty and NVE's product specifications.

An ISO 9001 Certified Company

NVE Corporation
11409 Valley View Road
Eden Prairie, MN 55344-3617 USA
Telephone: (952) 829-9217
Fax: (952) 829-9189
www.nve.com
e-mail: iso-info@nve.com

©NVE Corporation
All rights are reserved. Reproduction in whole or in part is prohibited without the prior written consent of the copyright owner.

ISB-DS-001-IL715/6/7-AE

November 2016

Looking for pricing, stock, or lifecycle information?

Click below to explore more details on WIN SOURCE:

 [View IL717-3E on WIN SOURCE](#)

 [NVE Corp Information](#)

Optimize Your Supply Chain with WIN SOURCE Solutions

-  Global Sourcing Solution
-  Obsolete Management
-  Cost Control Management
-  Shortage Management
-  Alternative Solution
-  Excess Inventory Management