



**THE DATASHEET OF
NTS0104PW-Q100J**



NTS0104-Q100

Dual supply translating transceiver; open drain; auto direction sensing

Rev. 2 — 23 May 2013

Product data sheet

1. General description

The NTS0104-Q100 is a 4-bit, dual supply translating transceiver with auto direction sensing, that enables bidirectional voltage level translation. It features two 4-bit input-output ports (An and Bn), one output enable input (OE) and two supply pins ($V_{CC(A)}$ and $V_{CC(B)}$). $V_{CC(A)}$ can be supplied with any voltage between 1.65 V and 3.6 V. $V_{CC(B)}$ can be supplied with any voltage between 2.3 V and 5.5 V. The range in supply voltages makes the device suitable for translating between any of the voltage nodes (1.8 V, 2.5 V, 3.3 V and 5.0 V). Pins An and OE are referenced to $V_{CC(A)}$ and pins Bn are referenced to $V_{CC(B)}$. A LOW level at pin OE causes the outputs to assume a high-impedance OFF-state. This device is fully specified for partial power-down applications using I_{OFF} . The I_{OFF} circuitry disables the output, preventing the damaging backflow current through the device when it is powered down.

This product has been qualified to the Automotive Electronics Council (AEC) standard Q100 (Grade 1) and is suitable for use in automotive applications.

2. Features and benefits

- Automotive product qualification in accordance with AEC-Q100 (Grade 1)
 - ◆ Specified from $-40\text{ }^{\circ}\text{C}$ to $+85\text{ }^{\circ}\text{C}$ and from $-40\text{ }^{\circ}\text{C}$ to $+125\text{ }^{\circ}\text{C}$
- Wide supply voltage range:
 - ◆ $V_{CC(A)}$: 1.65 V to 3.6 V and $V_{CC(B)}$: 2.3 V to 5.5 V
- Maximum data rates:
 - ◆ Push-pull: 50 Mbps
- I_{OFF} circuitry provides partial Power-down mode operation
- Inputs accept voltages up to 5.5 V
- ESD protection:
 - ◆ MIL-STD-883, method 3015 Class 2 exceeds 2500 V for A port
 - ◆ MIL-STD-883, method 3015 Class 3B exceeds 15000 V for B port
 - ◆ HBM JESD22-A114E Class 2 exceeds 2500 V for A port
 - ◆ HBM JESD22-A114E Class 3B exceeds 15000 V for B port
 - ◆ MM JESD22-A115-A exceeds 200 V ($C = 200\text{ pF}$, $R = 0\text{ }\Omega$)
- Latch-up performance exceeds 100 mA per JESD 78B Class II
- Multiple package options



3. Applications

- I²C/SMBus
- UART
- GPIO

4. Ordering information

Table 1. Ordering information

Type number	Package			Version
	Temperature range	Name	Description	
NTS0104PW-Q100	-40 °C to +125 °C	TSSOP14	plastic thin shrink small outline package; 14 leads; body width 4.4 mm	SOT402-1
NTS0104BQ-Q100	-40 °C to +125 °C	DHVQFN14	plastic dual in-line compatible thermal enhanced very thin quad flat package; no leads; 14 terminals; body 2.5 × 3 × 0.85 mm	SOT762-1
NTS0104UK-Q100	-40 °C to +125 °C	WLCSP12	wafer level chip-size package, 12 bumps; body 1.20 × 1.60 × 0.56 mm (Backside Coating included)	NTS0104UK-Q100

5. Marking

Table 2. Marking

Type number	Marking code
NTS0104PW-Q100	NTS0104
NTS0104BQ-Q100	S0104
NTS0104UK-Q100	s04

6. Functional diagram

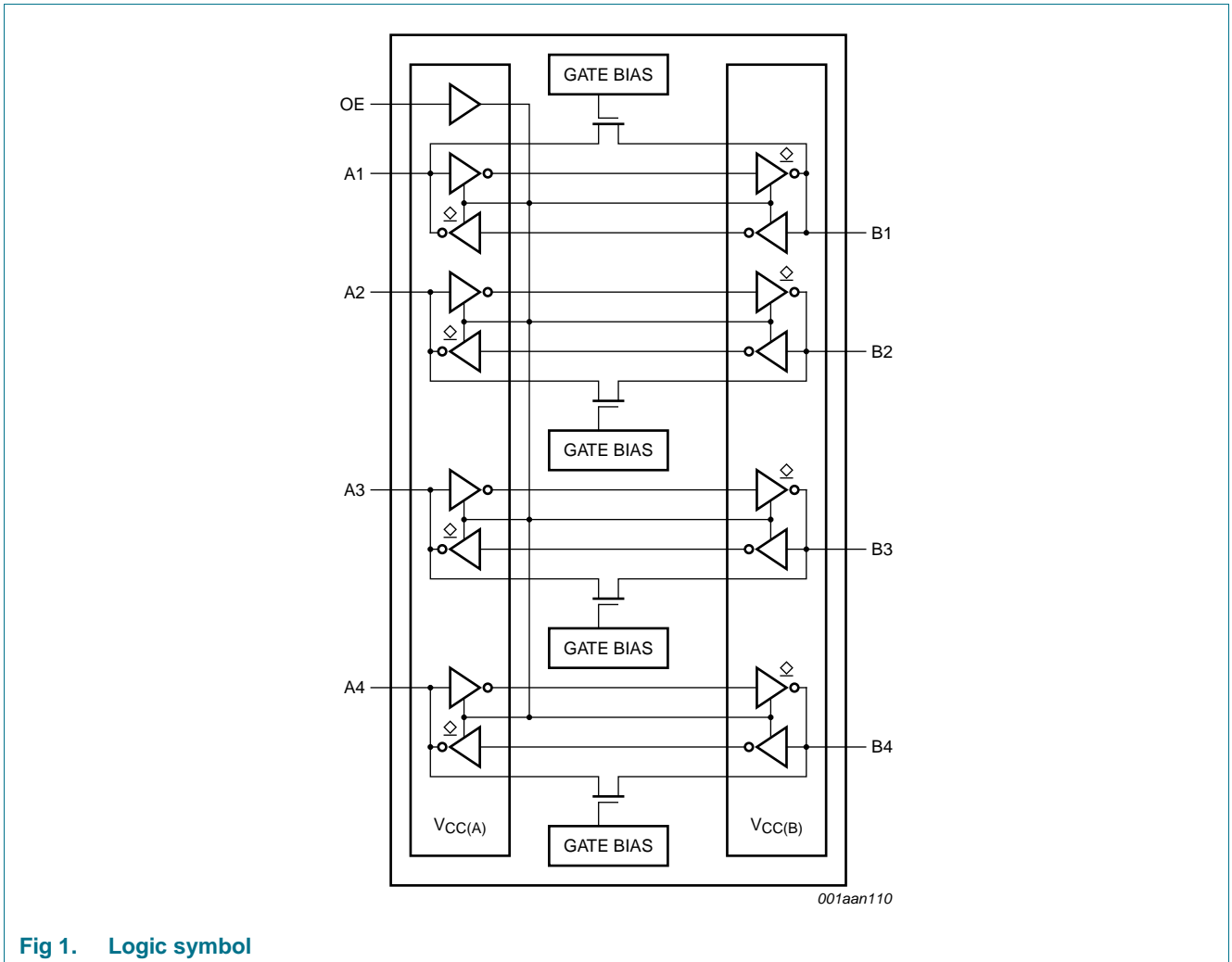

Fig 1. Logic symbol

7. Pinning information

7.1 Pinning

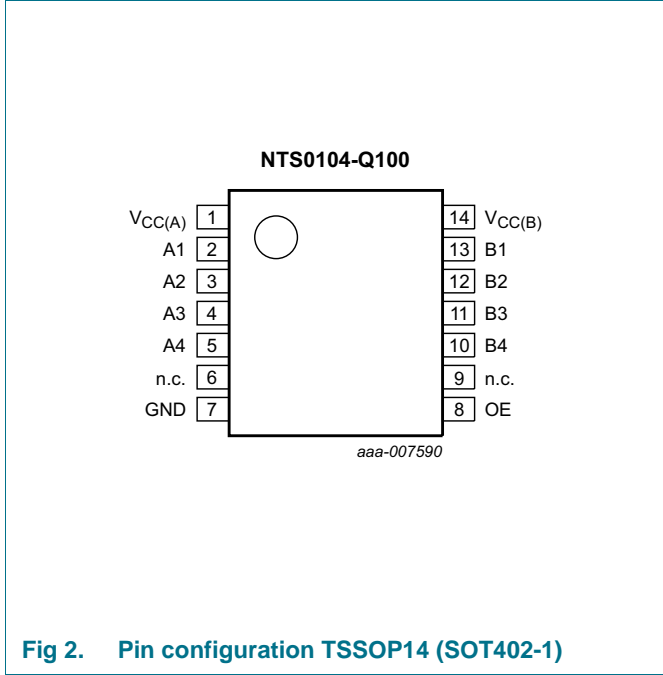

Fig 2. Pin configuration TSSOP14 (SOT402-1)

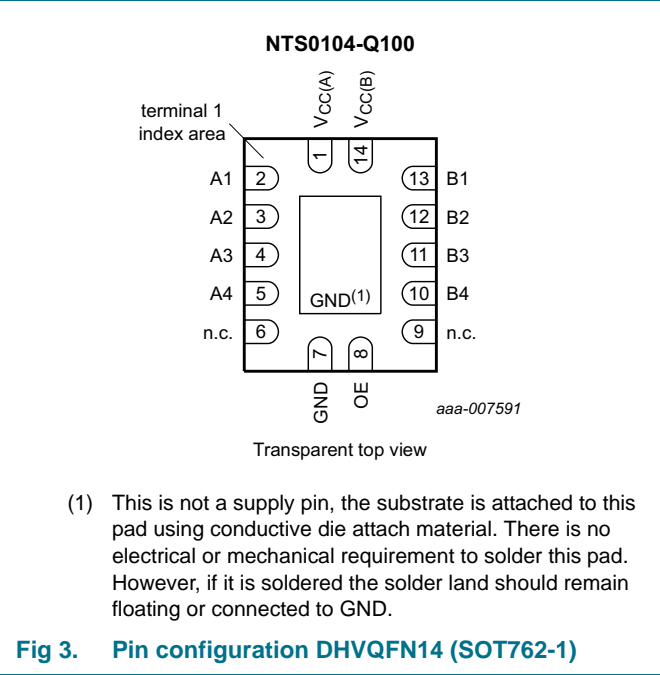

Fig 3. Pin configuration DHVQFN14 (SOT762-1)

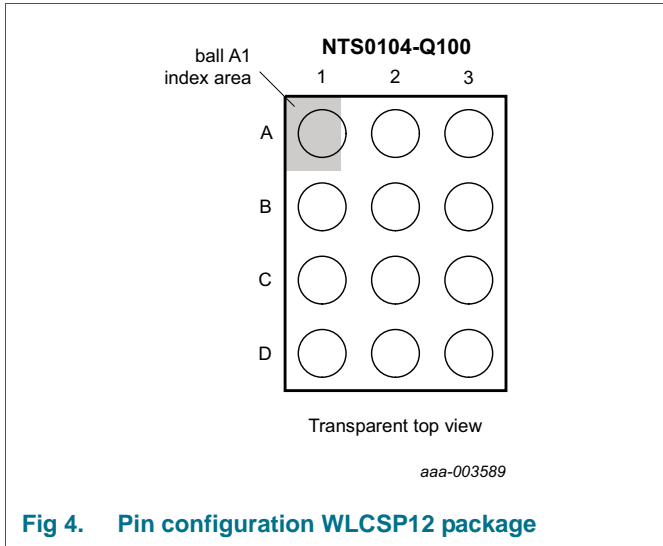

Fig 4. Pin configuration WLCSP12 package

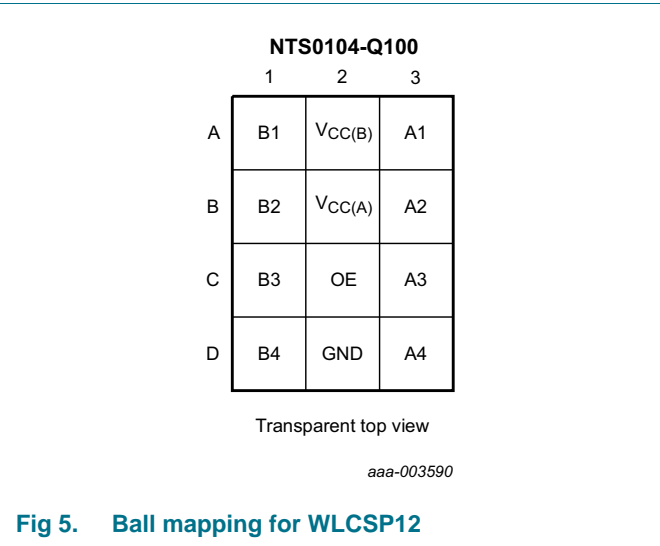

Fig 5. Ball mapping for WLCSP12

7.2 Pin description

Table 3. Pin description

Symbol	Pin	Ball	Description
	SOT402-1 and SOT762-1	WLCSP12	
V _{CC(A)}	1	B2	supply voltage A
A1, A2, A3, A4	2, 3, 4, 5	A3, B3, C3, D3	data input or output (referenced to V _{CC(A)})
n.c.	6, 9	-	not connected
GND	7	D2	ground (0 V)
OE	8	C2	output enable input (active HIGH; referenced to V _{CC(A)})
B4, B3, B2, B1	10, 11, 12, 13	D1, C1, B1, A1	data input or output (referenced to V _{CC(B)})
V _{CC(B)}	14	A2	supply voltage B

8. Functional description

Table 4. Function table^[1]

Supply voltage		Input	Input/output	
V _{CC(A)}	V _{CC(B)}	OE	An	Bn
1.65 V to V _{CC(B)}	2.3 V to 5.5 V	L	Z	Z
1.65 V to V _{CC(B)}	2.3 V to 5.5 V	H	input or output	output or input
GND ^[2]	GND ^[2]	X	Z	Z

[1] H = HIGH voltage level; L = LOW voltage level; X = don't care; Z = high-impedance OFF-state.

[2] When either V_{CC(A)} or V_{CC(B)} is at GND level, the device goes into power-down mode.

9. Limiting values

Table 5. Limiting values

In accordance with the Absolute Maximum Rating System (IEC 60134). Voltages are referenced to GND (ground = 0 V).

Symbol	Parameter	Conditions	Min	Max	Unit	
$V_{CC(A)}$	supply voltage A		-0.5	+6.5	V	
$V_{CC(B)}$	supply voltage B		-0.5	+6.5	V	
V_I	input voltage	A port and OE input	[1][2]	-0.5	+6.5	V
		B port	[1][2]	-0.5	+6.5	V
V_O	output voltage	Active mode	[1][2]			
		A or B port	-0.5	$V_{CCO} + 0.5$	V	
		Power-down or 3-state mode	[1]			
		A port	-0.5	+4.6	V	
		B port	-0.5	+6.5	V	
I_{IK}	input clamping current	$V_I < 0$ V	-50	-	mA	
I_{OK}	output clamping current	$V_O < 0$ V	-50	-	mA	
I_O	output current	$V_O = 0$ V to V_{CCO}	[2]	-	± 50	mA
I_{CC}	supply current	$I_{CC(A)}$ or $I_{CC(B)}$	-	100	mA	
I_{GND}	ground current		-100	-	mA	
T_{stg}	storage temperature		-65	+150	°C	
P_{tot}	total power dissipation	$T_{amb} = -40$ °C to +125 °C	[3]	-	250	mW

[1] The minimum input and minimum output voltage ratings may be exceeded if the input and output current ratings are observed.

[2] V_{CCO} is the supply voltage associated with the output.

[3] For TSSOP14 packages: above 60 °C the value of P_{tot} derates linearly at 5.5 mW/K.
For DHVQFN14 packages: above 60 °C the value of P_{tot} derates linearly at 4.5 mW/K.

10. Recommended operating conditions

Table 6. Recommended operating conditions[1][2]

Symbol	Parameter	Conditions	Min	Max	Unit
$V_{CC(A)}$	supply voltage A		1.65	3.6	V
$V_{CC(B)}$	supply voltage B		2.3	5.5	V
T_{amb}	ambient temperature		-40	+125	°C
$\Delta t/\Delta V$	input transition rise and fall rate	A or B port; push-pull driving			
		$V_{CC(A)} = 1.65$ V to 3.6 V; $V_{CC(B)} = 2.3$ V to 5.5 V	-	10	ns/V
		OE input			
		$V_{CC(A)} = 1.65$ V to 3.6 V; $V_{CC(B)} = 2.3$ V to 5.5 V	-	10	ns/V

[1] Hold the A and B sides of an unused I/O pair in the same state, either both at V_{CCI} or both at GND.

[2] $V_{CC(A)}$ must be less than or equal to $V_{CC(B)}$.

11. Static characteristics

Table 7. Typical static characteristics

At recommended operating conditions; voltages are referenced to GND (ground = 0 V); $T_{amb} = 25\text{ }^{\circ}\text{C}$.

Symbol	Parameter	Conditions	Min	Typ	Max	Unit
I_I	input leakage current	OE input; $V_I = 0\text{ V to }3.6\text{ V}$; $V_{CC(A)} = 1.65\text{ V to }3.6\text{ V}$; $V_{CC(B)} = 2.3\text{ V to }5.5\text{ V}$	-	-	± 1	μA
I_{OZ}	OFF-state output current	A or B port; $V_O = 0\text{ V or }V_{CCO}$; $V_{CC(A)} = 1.65\text{ V to }3.6\text{ V}$; $V_{CC(B)} = 2.3\text{ V to }5.5\text{ V}$	[1]	-	± 1	μA
I_{OFF}	power-off leakage current	A port; V_I or $V_O = 0\text{ V to }3.6\text{ V}$; $V_{CC(A)} = 0\text{ V}$; $V_{CC(B)} = 0\text{ V to }5.5\text{ V}$	-	-	± 1	μA
		B port; V_I or $V_O = 0\text{ V to }5.5\text{ V}$; $V_{CC(B)} = 0\text{ V}$; $V_{CC(A)} = 0\text{ V to }3.6\text{ V}$	-	-	± 1	μA
C_I	input capacitance	OE input; $V_{CC(A)} = 3.3\text{ V}$; $V_{CC(B)} = 3.3\text{ V}$	-	2	-	pF
$C_{I/O}$	input/output capacitance	A port	-	4	-	pF
		B port	-	7	-	pF
		A or B port; $V_{CC(A)} = 3.3\text{ V}$; $V_{CC(B)} = 3.3\text{ V}$	-	9	-	pF

[1] V_{CCO} is the supply voltage associated with the output.

Table 8. Typical supply current

At recommended operating conditions; voltages are referenced to GND (ground = 0 V); $T_{amb} = 25\text{ }^{\circ}\text{C}$.

$V_{CC(A)}$	$V_{CC(B)}$						Unit
	2.5 V		3.3 V		5.0 V		
	$I_{CC(A)}$	$I_{CC(B)}$	$I_{CC(A)}$	$I_{CC(B)}$	$I_{CC(A)}$	$I_{CC(B)}$	
1.8 V	0.1	0.5	0.1	1.5	0.1	4.6	μA
2.5 V	0.1	0.1	0.1	0.8	0.1	3.8	μA
3.3 V	-	-	0.1	0.1	0.1	2.8	μA

Table 9. Static characteristics

At recommended operating conditions; voltages are referenced to GND (ground = 0 V).

Symbol	Parameter	Conditions	-40 °C to +85 °C		-40 °C to +125 °C		Unit	
			Min	Max	Min	Max		
V_{IH}	HIGH-level input voltage	A port						
		$V_{CC(A)} = 1.65\text{ V to }1.95\text{ V}$; $V_{CC(B)} = 2.3\text{ V to }5.5\text{ V}$	[1]	$V_{CCI} - 0.2$	-	$V_{CCI} - 0.2$	-	V
		$V_{CC(A)} = 2.3\text{ V to }3.6\text{ V}$; $V_{CC(B)} = 2.3\text{ V to }5.5\text{ V}$	[1]	$V_{CCI} - 0.4$	-	$V_{CCI} - 0.4$	-	V
		B port						
		$V_{CC(A)} = 1.65\text{ V to }3.6\text{ V}$; $V_{CC(B)} = 2.3\text{ V to }5.5\text{ V}$	[1]	$V_{CCI} - 0.4$	-	$V_{CCI} - 0.4$	-	V
V_{IH}	HIGH-level input voltage	OE input						
		$V_{CC(A)} = 1.65\text{ V to }3.6\text{ V}$; $V_{CC(B)} = 2.3\text{ V to }5.5\text{ V}$		$0.65V_{CC(A)}$	-	$0.65V_{CC(A)}$	-	V

Table 9. Static characteristics ...continued

At recommended operating conditions; voltages are referenced to GND (ground = 0 V).

Symbol	Parameter	Conditions	-40 °C to +85 °C		-40 °C to +125 °C		Unit	
			Min	Max	Min	Max		
V _{IL}	LOW-level input voltage	A or B port V _{CC(A)} = 1.65 V to 3.6 V; V _{CC(B)} = 2.3 V to 5.5 V	-	0.15	-	0.15	V	
		OE input V _{CC(A)} = 1.65 V to 3.6 V; V _{CC(B)} = 2.3 V to 5.5 V	-	0.35V _{CC(A)}	-	0.35V _{CC(A)}	V	
V _{OH}	HIGH-level output voltage	A or B port; I _O = -20 μA V _{CC(A)} = 1.65 V to 3.6 V; V _{CC(B)} = 2.3 V to 5.5 V	[2]	0.67V _{CCO}	-	0.67V _{CCO}	-	V
V _{OL}	LOW-level output voltage	A or B port; I _O = 1 mA V _I ≤ 0.15 V; V _{CC(A)} = 1.65 V to 3.6 V; V _{CC(B)} = 2.3 V to 5.5 V	[2]	-	0.4	-	0.4	V
I _I	input leakage current	OE input; V _I = 0 V to 3.6 V; V _{CC(A)} = 1.65 V to 3.6 V; V _{CC(B)} = 2.3 V to 5.5 V	-	±2	-	±12	μA	
I _{OZ}	OFF-state output current	A or B port; V _O = 0 V or V _{CCO} ; V _{CC(A)} = 1.65 V to 3.6 V; V _{CC(B)} = 2.3 V to 5.5 V	[2]	-	±2	-	±12	μA
I _{OFF}	power-off leakage current	A port; V _I or V _O = 0 V to 3.6 V; V _{CC(A)} = 0 V; V _{CC(B)} = 0 V to 5.5 V	-	±2	-	±12	μA	
		B port; V _I or V _O = 0 V to 3.6 V; V _{CC(B)} = 0 V; V _{CC(A)} = 0 V to 3.6 V	-	±2	-	±12	μA	
I _{CC}	supply current	V _I = 0 V or V _{CCI} ; I _O = 0 A	[1]					
		I _{CC(A)}						
		V _{CC(A)} = 1.65 V to 3.6 V; V _{CC(B)} = 2.3 V to 5.5 V	-	2.4	-	15	μA	
		V _{CC(A)} = 3.6 V; V _{CC(B)} = 0 V	-	2.2	-	15	μA	
		V _{CC(A)} = 0 V; V _{CC(B)} = 5.5 V	-	-1	-	-8	μA	
		I _{CC(B)}						
		V _{CC(A)} = 1.65 V to 3.6 V; V _{CC(B)} = 2.3 V to 5.5 V	-	12	-	30	μA	
		V _{CC(A)} = 3.6 V; V _{CC(B)} = 0 V	-	-1	-	-5	μA	
		V _{CC(A)} = 0 V; V _{CC(B)} = 5.5 V	-	1	-	6	μA	
		I _{CC(A)} + I _{CC(B)}						
V _{CC(A)} = 1.65 V to 3.6 V; V _{CC(B)} = 2.3 V to 5.5 V	-	14.4	-	45	μA			

[1] V_{CCI} is the supply voltage associated with the input.

[2] V_{CCO} is the supply voltage associated with the output.

12. Dynamic characteristics

Table 10. Dynamic characteristics for temperature range $-40\text{ }^{\circ}\text{C}$ to $+85\text{ }^{\circ}\text{C}$ ^[1]

Voltages are referenced to GND (ground = 0 V); for test circuit see [Figure 8](#); for wave forms see [Figure 6](#) and [Figure 7](#).

Symbol	Parameter	Conditions	$V_{CC(B)}$						Unit
			$2.5\text{ V} \pm 0.2\text{ V}$		$3.3\text{ V} \pm 0.3\text{ V}$		$5.0\text{ V} \pm 0.5\text{ V}$		
			Min	Max	Min	Max	Min	Max	
$V_{CC(A)} = 1.8\text{ V} \pm 0.15\text{ V}$									
t_{PHL}	HIGH to LOW propagation delay	A to B	-	4.6	-	4.7	-	5.8	ns
t_{PLH}	LOW to HIGH propagation delay	A to B	-	6.8	-	6.8	-	7.0	ns
t_{PHL}	HIGH to LOW propagation delay	B to A	-	4.4	-	4.5	-	4.7	ns
t_{PLH}	LOW to HIGH propagation delay	B to A	-	5.3	-	4.5	-	0.5	ns
t_{en}	enable time	OE to A; B	-	200	-	200	-	200	ns
t_{dis}	disable time	OE to A; no external load [2]	-	35	-	35	-	35	ns
		OE to B; no external load [2]	-	35	-	35	-	35	ns
		OE to A	-	230	-	230	-	230	ns
		OE to B	-	200	-	200	-	200	ns
t_{TLH}	LOW to HIGH output transition time	A port	3.2	9.5	2.3	9.3	1.8	7.6	ns
		B port	3.3	10.8	2.7	9.1	2.7	7.6	ns
t_{THL}	HIGH to LOW output transition time	A port	2.0	5.9	1.9	6.0	1.7	13.3	ns
		B port	2.9	7.6	2.8	7.5	2.8	10.0	ns
$t_{sk(o)}$	output skew time	between channels [3]	-	0.7	-	0.7	-	0.7	ns
t_W	pulse width	data inputs	20	-	20	-	20	-	ns
f_{data}	data rate		-	50	-	50	-	50	Mbps
$V_{CC(A)} = 2.5\text{ V} \pm 0.2\text{ V}$									
t_{PHL}	HIGH to LOW propagation delay	A to B	-	3.2	-	3.3	-	3.4	ns
t_{PLH}	LOW to HIGH propagation delay	A to B	-	3.5	-	4.1	-	4.4	ns
t_{PHL}	HIGH to LOW propagation delay	B to A	-	3.0	-	3.6	-	4.3	ns
t_{PLH}	LOW to HIGH propagation delay	B to A	-	2.5	-	1.6	-	0.7	ns
t_{en}	enable time	OE to A; B	-	200	-	200	-	200	ns
t_{dis}	disable time	OE to A; no external load [2]	-	35	-	35	-	35	ns
		OE to B; no external load [2]	-	35	-	35	-	35	ns
		OE to A	-	200	-	200	-	200	ns
		OE to B	-	200	-	200	-	200	ns
t_{TLH}	LOW to HIGH output transition time	A port	2.8	7.4	2.6	6.6	1.8	6.2	ns
		B port	3.2	8.3	2.9	7.9	2.4	6.8	ns

Table 10. Dynamic characteristics for temperature range $-40\text{ }^{\circ}\text{C}$ to $+85\text{ }^{\circ}\text{C}$ ^[1]

Voltages are referenced to GND (ground = 0 V); for test circuit see [Figure 8](#); for wave forms see [Figure 6](#) and [Figure 7](#).

Symbol	Parameter	Conditions	$V_{CC(B)}$						Unit
			$2.5\text{ V} \pm 0.2\text{ V}$		$3.3\text{ V} \pm 0.3\text{ V}$		$5.0\text{ V} \pm 0.5\text{ V}$		
			Min	Max	Min	Max	Min	Max	
t_{THL}	HIGH to LOW output transition time	A port	1.9	5.7	1.9	5.5	1.8	5.3	ns
		B port	2.2	7.8	2.4	6.7	2.6	6.6	ns
$t_{sk(o)}$	output skew time	between channels [3]	-	0.7	-	0.7	-	0.7	ns
t_W	pulse width	data inputs	20	-	20	-	20	-	ns
f_{data}	data rate		-	50	-	50	-	50	Mbps
$V_{CC(A)} = 3.3\text{ V} \pm 0.3\text{ V}$									
t_{PHL}	HIGH to LOW propagation delay	A to B	-	-	-	2.4	-	3.1	ns
t_{PLH}	LOW to HIGH propagation delay	A to B	-	-	-	4.2	-	4.4	ns
t_{PHL}	HIGH to LOW propagation delay	B to A	-	-	-	2.5	-	3.3	ns
t_{PLH}	LOW to HIGH propagation delay	B to A	-	-	-	2.5	-	2.6	ns
t_{en}	enable time	OE to A; B	-	-	-	200	-	200	ns
t_{dis}	disable time	OE to A; no external load [2]	-	-	-	35	-	35	ns
		OE to B; no external load [2]	-	-	-	35	-	35	ns
		OE to A	-	-	-	260	-	260	ns
		OE to B	-	-	-	200	-	200	ns
t_{TLH}	LOW to HIGH output transition time	A port	-	-	2.3	5.6	1.9	5.9	ns
		B port	-	-	2.5	6.4	2.1	7.4	ns
t_{THL}	HIGH to LOW output transition time	A port	-	-	2.0	5.4	1.9	5.0	ns
		B port	-	-	2.3	7.4	2.4	7.6	ns
$t_{sk(o)}$	output skew time	between channels [3]	-	-	-	0.7	-	0.7	ns
t_W	pulse width	data inputs	-	-	20	-	20	-	ns
f_{data}	data rate		-	-	-	50	-	50	Mbps

[1] t_{en} is the same as t_{pZL} and t_{pZH} .

t_{dis} is the same as t_{pLZ} and t_{pHZ} .

[2] Delay between OE going LOW and when the outputs are disabled.

[3] Skew between any two outputs of the same package switching in the same direction.

Table 11. Dynamic characteristics for temperature range –40 °C to +125 °C^[1]

Voltages are referenced to GND (ground = 0 V); for test circuit see [Figure 8](#); for wave forms see [Figure 6](#) and [Figure 7](#).

Symbol	Parameter	Conditions	V _{CC(B)}						Unit
			2.5 V ± 0.2 V		3.3 V ± 0.3 V		5.0 V ± 0.5 V		
			Min	Max	Min	Max	Min	Max	
V_{CC(A)} = 1.8 V ± 0.15 V									
t _{PHL}	HIGH to LOW propagation delay	A to B	-	5.8	-	5.9	-	7.3	ns
t _{PLH}	LOW to HIGH propagation delay	A to B	-	8.5	-	8.5	-	8.8	ns
t _{PHL}	HIGH to LOW propagation delay	B to A	-	5.5	-	5.7	-	5.9	ns
t _{PLH}	LOW to HIGH propagation delay	B to A	-	6.7	-	5.7	-	0.7	ns
t _{en}	enable time	OE to A; B	-	200	-	200	-	200	ns
t _{dis}	disable time	OE to A; no external load ^[2]	-	45	-	45	-	45	ns
		OE to B; no external load ^[2]	-	45	-	45	-	45	ns
		OE to A	-	250	-	250	-	250	ns
		OE to B	-	220	-	220	-	220	ns
t _{TLH}	LOW to HIGH output transition time	A port	3.2	11.9	2.3	11.7	1.8	9.5	ns
		B port	3.3	13.5	2.7	11.4	2.7	9.5	ns
t _{THL}	HIGH to LOW output transition time	A port	2.0	7.4	1.9	7.5	1.7	16.7	ns
		B port	2.9	9.5	2.8	9.4	2.8	12.5	ns
t _{sk(o)}	output skew time	between channels ^[3]	-	0.8	-	0.8	-	0.8	ns
t _W	pulse width	data inputs	20	-	20	-	20	-	ns
f _{data}	data rate		-	50	-	50	-	50	Mbps
V_{CC(A)} = 2.5 V ± 0.2 V									
t _{PHL}	HIGH to LOW propagation delay	A to B	-	4.0	-	4.2	-	4.3	ns
t _{PLH}	LOW to HIGH propagation delay	A to B	-	4.4	-	5.2	-	5.5	ns
t _{PHL}	HIGH to LOW propagation delay	B to A	-	3.8	-	4.5	-	5.4	ns
t _{PLH}	LOW to HIGH propagation delay	B to A	-	3.2	-	2.0	-	0.9	ns
t _{en}	enable time	OE to A; B	-	200	-	200	-	200	ns
t _{dis}	disable time	OE to A; no external load ^[2]	-	45	-	45	-	45	ns
		OE to B; no external load ^[2]	-	45	-	45	-	45	ns
		OE to A	-	220	-	220	-	220	ns
		OE to B	-	220	-	220	-	220	ns
t _{TLH}	LOW to HIGH output transition time	A port	2.8	9.3	2.6	8.3	1.8	7.8	ns
		B port	3.2	10.4	2.9	9.7	2.4	8.3	ns

Table 11. Dynamic characteristics for temperature range $-40\text{ }^{\circ}\text{C}$ to $+125\text{ }^{\circ}\text{C}$ ^[1] ...continued
 Voltages are referenced to GND (ground = 0 V); for test circuit see [Figure 8](#); for wave forms see [Figure 6](#) and [Figure 7](#).

Symbol	Parameter	Conditions	$V_{CC(B)}$						Unit
			$2.5\text{ V} \pm 0.2\text{ V}$		$3.3\text{ V} \pm 0.3\text{ V}$		$5.0\text{ V} \pm 0.5\text{ V}$		
			Min	Max	Min	Max	Min	Max	
t_{THL}	HIGH to LOW output transition time	A port	1.9	7.2	1.9	6.9	1.8	6.7	ns
		B port	2.2	9.8	2.4	8.4	2.6	8.3	ns
$t_{sk(o)}$	output skew time	between channels ^[3]	-	0.8	-	0.8	-	0.8	ns
t_W	pulse width	data inputs	20	-	20	-	20	-	ns
f_{data}	data rate		-	50	-	50	-	50	Mbps
$V_{CC(A)} = 3.3\text{ V} \pm 0.3\text{ V}$									
t_{PHL}	HIGH to LOW propagation delay	A to B	-	-	-	3.0	-	3.9	ns
t_{PLH}	LOW to HIGH propagation delay	A to B	-	-	-	5.3	-	5.5	ns
t_{PHL}	HIGH to LOW propagation delay	B to A	-	-	-	3.2	-	4.2	ns
t_{PLH}	LOW to HIGH propagation delay	B to A	-	-	-	3.2	-	3.3	ns
t_{en}	enable time	OE to A; B	-	-	-	200	-	200	ns
t_{dis}	disable time	OE to A; no external load ^[2]	-	-	-	45	-	45	ns
		OE to B; no external load ^[2]	-	-	-	45	-	45	ns
		OE to A	-	-	-	280	-	280	ns
		OE to B	-	-	-	220	-	220	ns
t_{TLH}	LOW to HIGH output transition time	A port	-	-	2.3	7.0	1.9	7.4	ns
		B port	-	-	2.5	8.0	2.1	9.3	ns
t_{THL}	HIGH to LOW output transition time	A port	-	-	2.0	6.8	1.9	6.3	ns
		B port	-	-	2.3	9.3	2.4	9.5	ns
$t_{sk(o)}$	output skew time	between channels ^[3]	-	-	-	0.8	-	0.8	ns
t_W	pulse width	data inputs	-	-	20	-	20	-	ns
f_{data}	data rate		-	-	-	50	-	50	Mbps

[1] t_{en} is the same as t_{pZL} and t_{pZH} .

t_{dis} is the same as t_{pLZ} and t_{pHZ} .

[2] Delay between OE going LOW and when the outputs are disabled.

[3] Skew between any two outputs of the same package switching in the same direction.

13. Waveforms

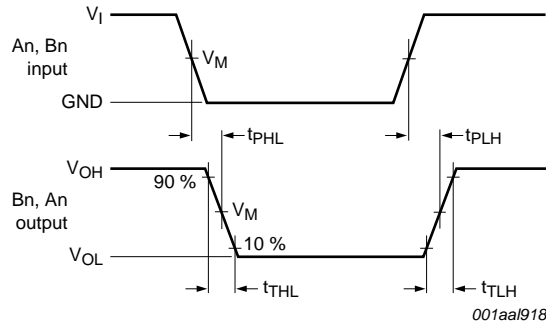

Measurement points are given in [Table 12](#).
 V_{OL} and V_{OH} are typical output voltage levels that occur with the output load.

Fig 6. The data input (An, Bn) to data output (Bn, An) propagation delay times

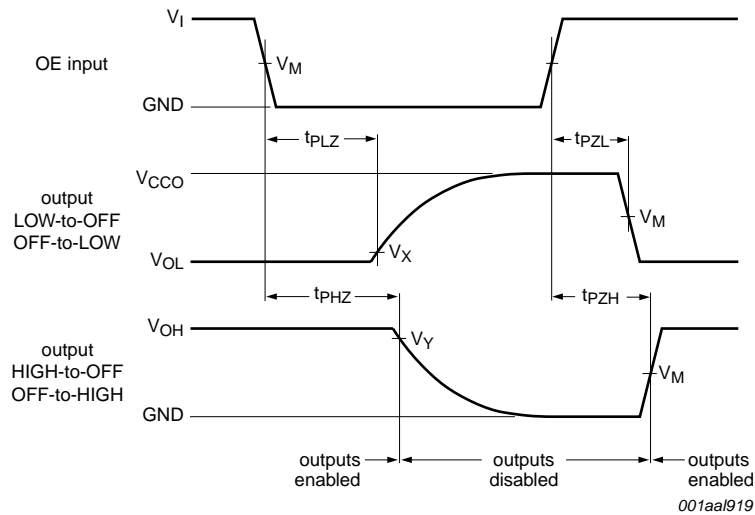

Measurement points are given in [Table 12](#).
 V_{OL} and V_{OH} are typical output voltage levels that occur with the output load.

Fig 7. Enable and disable times

Table 12. Measurement points^{[1][2]}

Supply voltage	Input	Output		
V_{CCO}	V_M	V_M	V_X	V_Y
1.8 V ± 0.15 V	0.5 V_{CCI}	0.5 V_{CCO}	$V_{OL} + 0.15$ V	$V_{OH} - 0.15$ V
2.5 V ± 0.2 V	0.5 V_{CCI}	0.5 V_{CCO}	$V_{OL} + 0.15$ V	$V_{OH} - 0.15$ V
3.3 V ± 0.3 V	0.5 V_{CCI}	0.5 V_{CCO}	$V_{OL} + 0.3$ V	$V_{OH} - 0.3$ V
5.0 V ± 0.5 V	0.5 V_{CCI}	0.5 V_{CCO}	$V_{OL} + 0.3$ V	$V_{OH} - 0.3$ V

[1] V_{CCI} is the supply voltage associated with the input.
 [2] V_{CCO} is the supply voltage associated with the output.

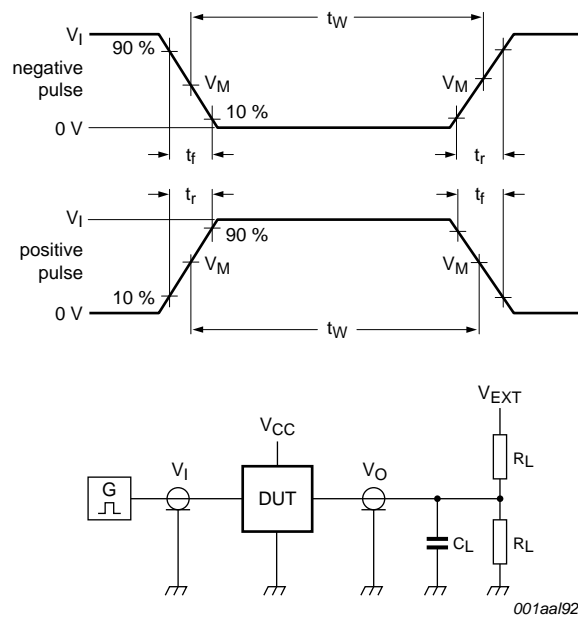

Test data is given in [Table 13](#).

All input pulses are supplied by generators having the following characteristics: PRR ≤ 10 MHz; Z_O = 50 Ω; dV/dt ≥ 1.0 V/ns.

R_L = Load resistance.

C_L = Load capacitance including jig and probe capacitance.

V_{EXT} = External voltage for measuring switching times.

Fig 8. Test circuit for measuring switching times

Table 13. Test data

Supply voltage		Input		Load		V _{EXT}		
V _{CC(A)}	V _{CC(B)}	V _I ^[1]	Δt/ΔV	C _L	R _L ^[2]	t _{PLH} , t _{PHL}	t _{PZH} , t _{PHZ}	t _{PZL} , t _{PLZ} ^[3]
1.65 V to 3.6 V	2.3 V to 5.5 V	V _{CCI}	≤ 1.0 ns/V	15 pF	50 kΩ, 1 MΩ	open	open	2V _{CCO}

[1] V_{CCI} is the supply voltage associated with the input.

[2] For measuring data rate, pulse width, propagation delay and output rise and fall measurements, R_L = 1 MΩ. For measuring enable and disable times, R_L = 50 kΩ.

[3] V_{CCO} is the supply voltage associated with the output.

14. Application information

14.1 Applications

Voltage level-translation applications. The NTS0104-Q100 can be used in point-to-point applications to interface between devices or systems operating at different supply voltages. The device is primarily targeted at I²C or 1-wire which use open-drain drivers. Although it may also be used in applications where push-pull drivers are connected to the ports, the NTB0104-Q100 may be more suitable.

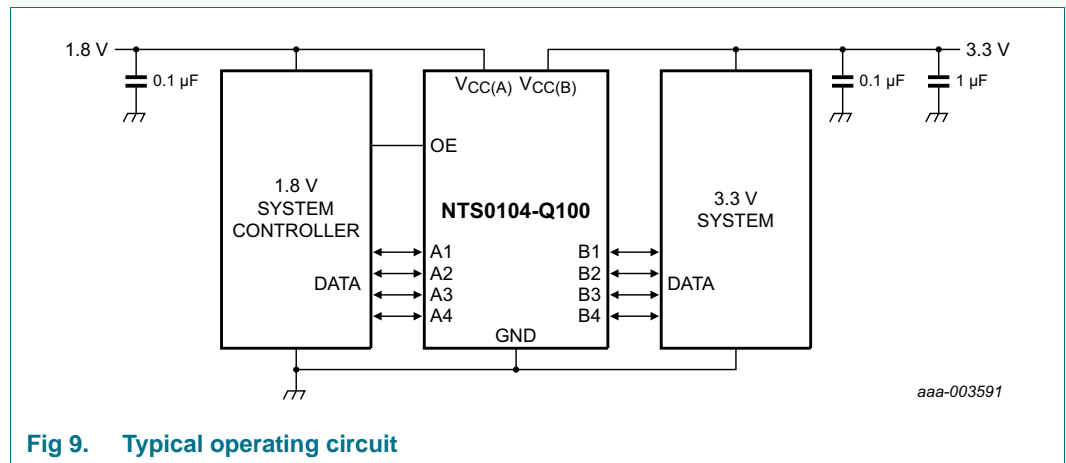

Fig 9. Typical operating circuit

14.2 Architecture

The architecture of the NTS0104-Q100 is shown in Figure 10. The device does not require an extra input signal to control the direction of data flow from A to B or B to A.

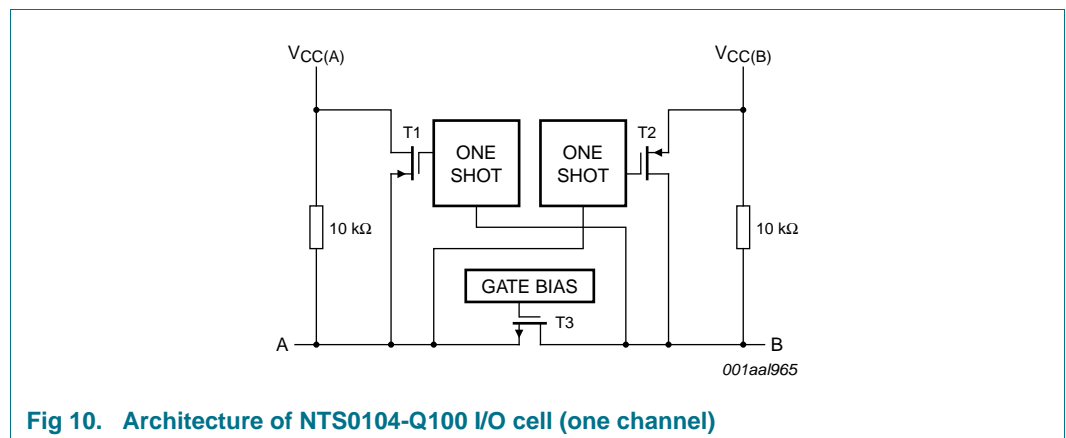

Fig 10. Architecture of NTS0104-Q100 I/O cell (one channel)

The NTS0104-Q100 is a "switch" type voltage translator, it employs two key circuits to enable voltage translation:

1. A pass-gate transistor (N-channel) that ties the ports together.
2. An output edge-rate accelerator that detects and accelerates rising edges on the I/O pins.

The gate bias voltage of the pass gate transistor (T3) is set at approximately one threshold voltage above the V_{CC} level of the low-voltage side. During a LOW-to-HIGH transition, the output one-shot accelerates the output transition. This acceleration is achieved by switching on the PMOS transistors (T1, T2) bypassing the 10 k Ω pull-up resistors and increasing current drive capability. The one-shot is activated once the input transition reaches approximately $V_{CC}/2$; it is de-activated approximately 50 ns after the output reaches $V_{CCO}/2$. During the acceleration time, the driver output resistance is between approximately 50 Ω and 70 Ω . To avoid signal contention and minimize dynamic I_{CC} , wait for the one-shot circuit to turn-off before applying a signal in the opposite direction. Pull-up resistors are included in the device for DC current sourcing capability.

14.3 Input driver requirements

As the NTS0104-Q100 is a switch type translator, properties of the input driver directly affect the output signal. The external open-drain or push-pull driver applied to an I/O, determines the static current sinking capability of the system. The maximum data rate, HIGH-to-LOW output transition time (t_{THL}) and propagation delay (t_{PHL}), are dependent upon the output impedance and edge-rate of the external driver. The limits provided for these parameters in the data sheet assume a driver with output impedance below 50 Ω is used.

14.4 Output load considerations

The maximum lumped capacitive load that can be driven is dependant upon the one-shot pulse duration. In cases with very heavy capacitive loading, there is a risk that the output does not reach the positive rail within the one-shot pulse duration.

To avoid excessive capacitive loading and to ensure correct triggering of the one-shot, use short trace lengths and low capacitance connectors on NTS0104-Q100 PCB layouts. To ensure low impedance termination and avoid output signal oscillations and one-shot retriggering, control the length of the PCB trace. The PCB trace must limit the round-trip delay of any reflection to within the one-shot pulse duration (approximately 50 ns).

14.5 Power-up

During operation $V_{CC(A)}$ must never be higher than $V_{CC(B)}$. However, during power-up $V_{CC(A)} \geq V_{CC(B)}$ does not damage the device. This means that either power supply can be ramped up first. There is no special power-up sequencing required. The NTS0104-Q100 includes circuitry that disables all output ports when either $V_{CC(A)}$ or $V_{CC(B)}$ is switched off.

14.6 Enable and disable

An output enable input (OE) is used to disable the device. Setting OE = LOW causes all I/Os to assume the high-impedance OFF-state. The disable time (t_{dis} with no external load) indicates the delay between when OE goes LOW and when outputs actually become disabled. The enable time (t_{en}) indicates the amount of time required for one one-shot circuit to become operational after OE is taken HIGH. To ensure the high-impedance OFF-state during power-up or power-down, tie pin OE to GND through a pull-down resistor. The current-sourcing capability of the driver determines the minimum value of the resistor.

14.7 Pull-up or pull-down resistors on I/Os lines

Each A port I/O has an internal 10 k Ω pull-up resistor to $V_{CC(A)}$. Each B port I/O has an internal 10 k Ω pull-up resistor to $V_{CC(B)}$. If a smaller value of pull-up resistor is required, add an external resistor in parallel to the internal 10 k Ω . The smaller value, affects the V_{OL} level. When OE goes LOW, the internal pull-ups of the NTS0104-Q100 are disabled.

15. Package outline

TSSOP14: plastic thin shrink small outline package; 14 leads; body width 4.4 mm

SOT402-1

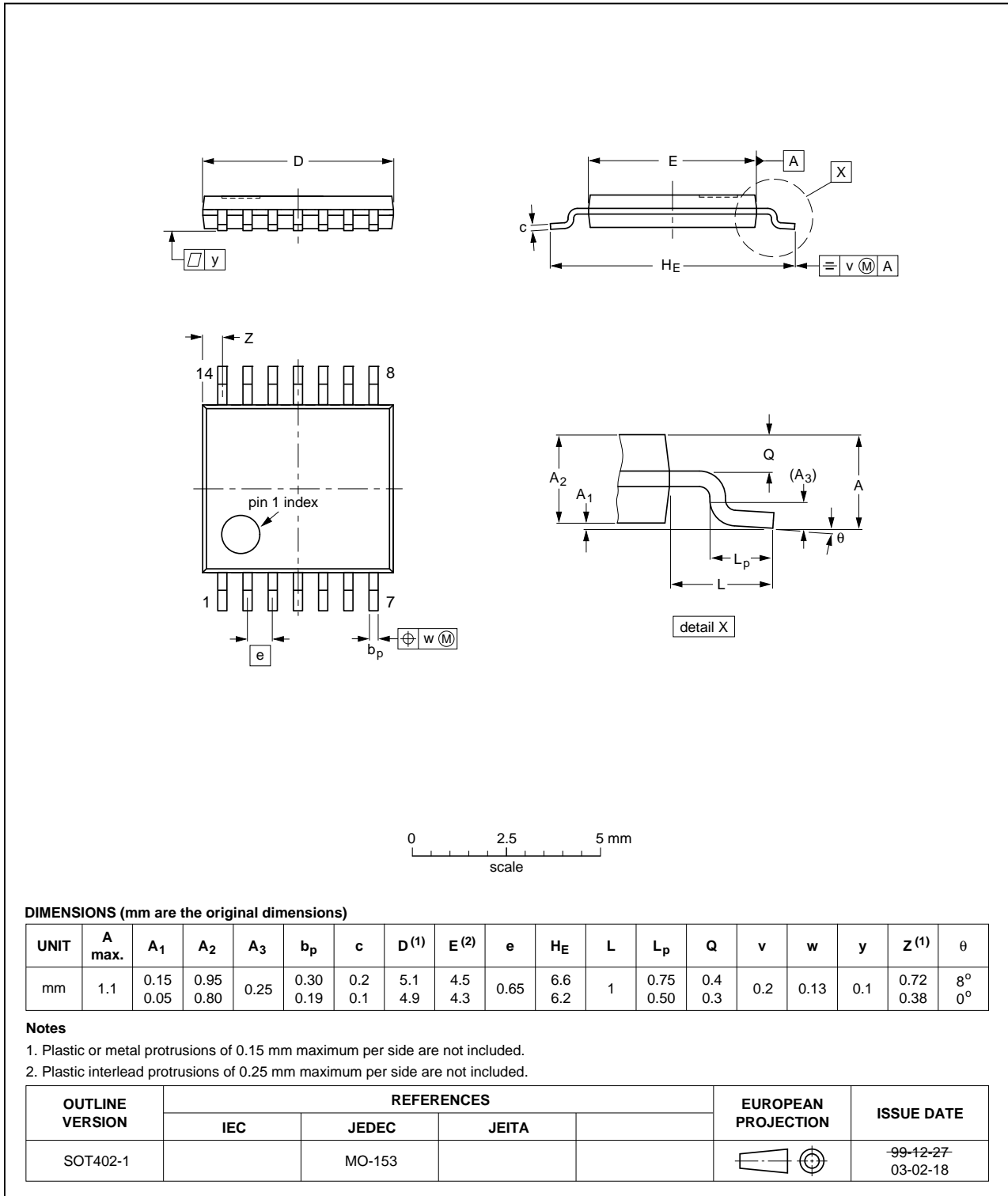

Fig 11. Package outline SOT402-1 (TSSOP14)

DHVQFN14: plastic dual in-line compatible thermal enhanced very thin quad flat package; no leads; 14 terminals; body 2.5 x 3 x 0.85 mm

SOT762-1

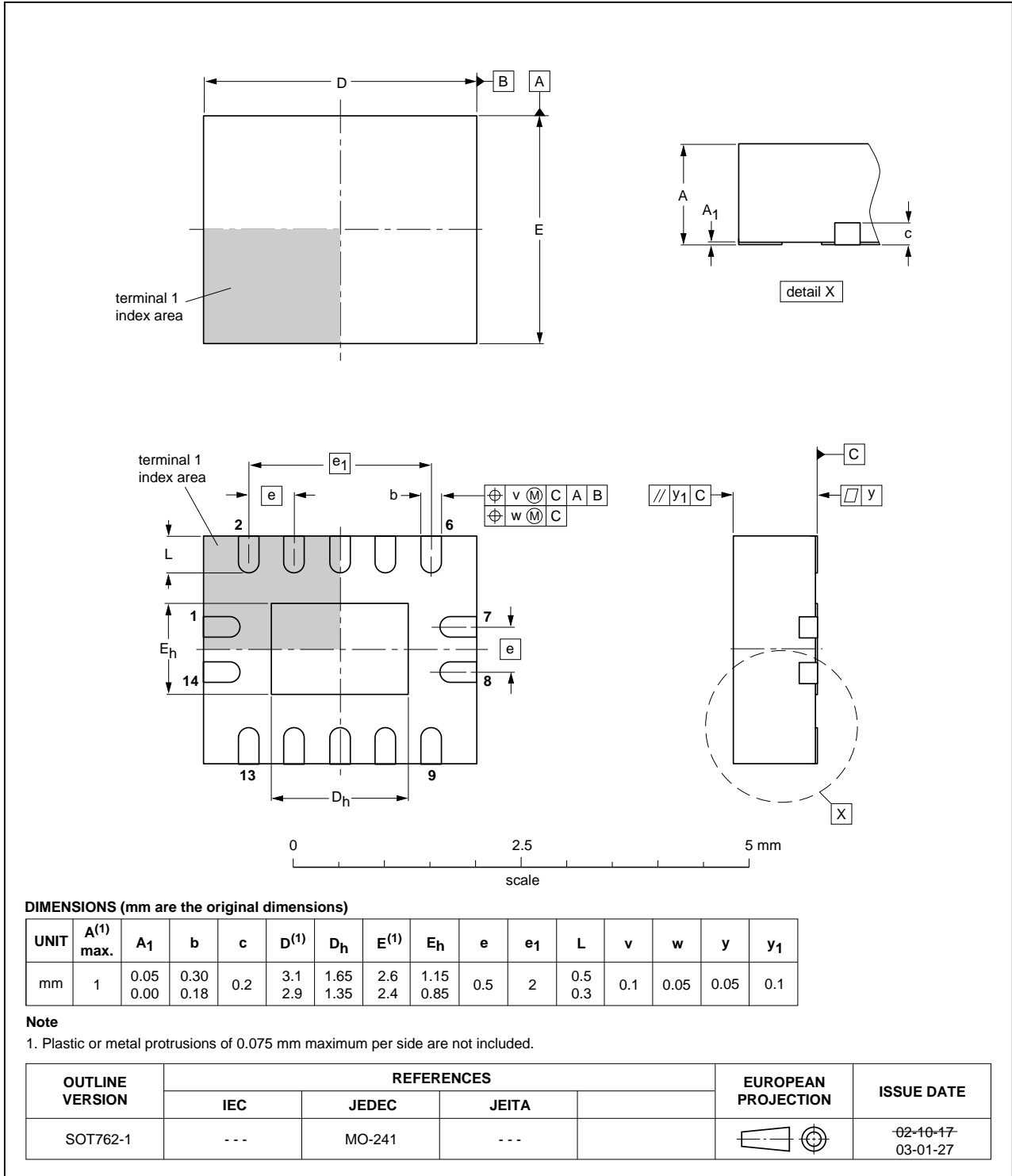

Fig 12. Package outline SOT762-1 (DHVQFN14)

WLCSP12: wafer level chip-size package,
12 bumps; body 1.20 x 1.60 x 0.56 mm. (Backside Coating included)

NTS0104UK-Q100

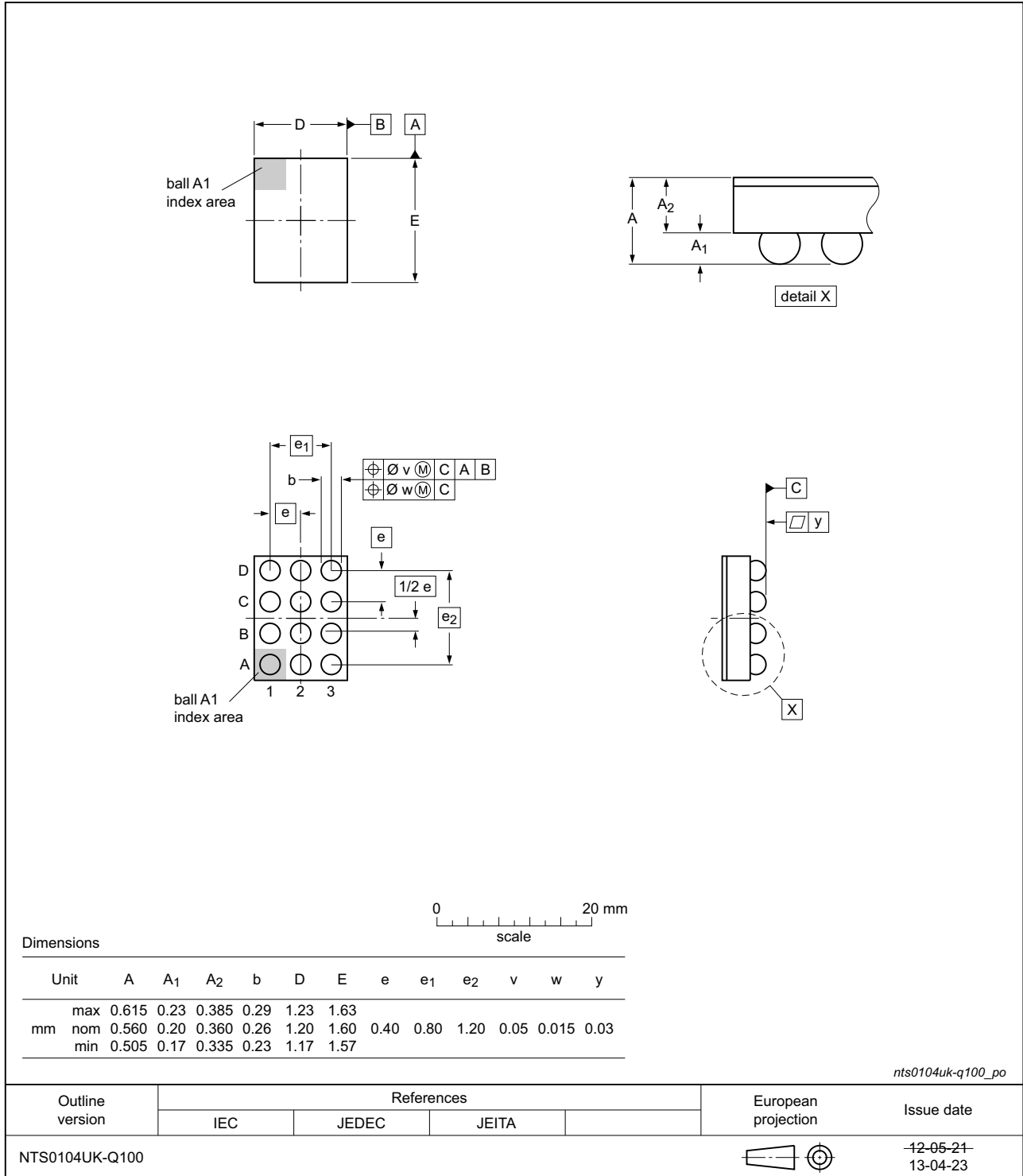

Fig 13. Package outline WLCSP12 package

16. Abbreviations

Table 14. Abbreviations

Acronym	Description
CDM	Charged Device Model
CMOS	Complementary Metal Oxide Semiconductor
DUT	Device Under Test
ESD	ElectroStatic Discharge
GPIO	General Purpose Input Output
MIL	Military
HBM	Human Body Model
I ² C	Inter-Integrated Circuit
MM	Machine Model
SMBus	System Management Bus
UART	Universal Asynchronous Receiver Transmitter

17. Revision history

Table 15. Revision history

Document ID	Release date	Data sheet status	Change notice	Supersedes
NTS0104_Q100 v.2	20130523	Product data sheet	-	NTS0104_Q100 v.1
Modifications:	<ul style="list-style-type: none"> added type numbers NTS0104PW-Q100 and NTS0104BQ-Q100. 			
NTS0104_Q100 v.1	20120807	Product data sheet	-	-

18. Legal information

18.1 Data sheet status

Document status ^{[1][2]}	Product status ^[3]	Definition
Objective [short] data sheet	Development	This document contains data from the objective specification for product development.
Preliminary [short] data sheet	Qualification	This document contains data from the preliminary specification.
Product [short] data sheet	Production	This document contains the product specification.

[1] Please consult the most recently issued document before initiating or completing a design.

[2] The term 'short data sheet' is explained in section "Definitions".

[3] The product status of device(s) described in this document may have changed since this document was published and may differ in case of multiple devices. The latest product status information is available on the Internet at URL <http://www.nxp.com>.

18.2 Definitions

Draft — The document is a draft version only. The content is still under internal review and subject to formal approval, which may result in modifications or additions. NXP Semiconductors does not give any representations or warranties as to the accuracy or completeness of information included herein and shall have no liability for the consequences of use of such information.

Short data sheet — A short data sheet is an extract from a full data sheet with the same product type number(s) and title. A short data sheet is intended for quick reference only and should not be relied upon to contain detailed and full information. For detailed and full information see the relevant full data sheet, which is available on request via the local NXP Semiconductors sales office. In case of any inconsistency or conflict with the short data sheet, the full data sheet shall prevail.

Product specification — The information and data provided in a Product data sheet shall define the specification of the product as agreed between NXP Semiconductors and its customer, unless NXP Semiconductors and customer have explicitly agreed otherwise in writing. In no event however, shall an agreement be valid in which the NXP Semiconductors product is deemed to offer functions and qualities beyond those described in the Product data sheet.

18.3 Disclaimers

Limited warranty and liability — Information in this document is believed to be accurate and reliable. However, NXP Semiconductors does not give any representations or warranties, expressed or implied, as to the accuracy or completeness of such information and shall have no liability for the consequences of use of such information. NXP Semiconductors takes no responsibility for the content in this document if provided by an information source outside of NXP Semiconductors.

In no event shall NXP Semiconductors be liable for any indirect, incidental, punitive, special or consequential damages (including - without limitation - lost profits, lost savings, business interruption, costs related to the removal or replacement of any products or rework charges) whether or not such damages are based on tort (including negligence), warranty, breach of contract or any other legal theory.

Notwithstanding any damages that customer might incur for any reason whatsoever, NXP Semiconductors' aggregate and cumulative liability towards customer for the products described herein shall be limited in accordance with the *Terms and conditions of commercial sale* of NXP Semiconductors.

Right to make changes — NXP Semiconductors reserves the right to make changes to information published in this document, including without limitation specifications and product descriptions, at any time and without notice. This document supersedes and replaces all information supplied prior to the publication hereof.

Suitability for use in automotive applications — This NXP Semiconductors product has been qualified for use in automotive applications. Unless otherwise agreed in writing, the product is not designed, authorized or warranted to be suitable for use in life support, life-critical or safety-critical systems or equipment, nor in applications where failure or malfunction of an NXP Semiconductors product can reasonably be expected to result in personal injury, death or severe property or environmental damage. NXP Semiconductors and its suppliers accept no liability for inclusion and/or use of NXP Semiconductors products in such equipment or applications and therefore such inclusion and/or use is at the customer's own risk.

Applications — Applications that are described herein for any of these products are for illustrative purposes only. NXP Semiconductors makes no representation or warranty that such applications will be suitable for the specified use without further testing or modification.

Customers are responsible for the design and operation of their applications and products using NXP Semiconductors products, and NXP Semiconductors accepts no liability for any assistance with applications or customer product design. It is customer's sole responsibility to determine whether the NXP Semiconductors product is suitable and fit for the customer's applications and products planned, as well as for the planned application and use of customer's third party customer(s). Customers should provide appropriate design and operating safeguards to minimize the risks associated with their applications and products.

NXP Semiconductors does not accept any liability related to any default, damage, costs or problem which is based on any weakness or default in the customer's applications or products, or the application or use by customer's third party customer(s). Customer is responsible for doing all necessary testing for the customer's applications and products using NXP Semiconductors products in order to avoid a default of the applications and the products or of the application or use by customer's third party customer(s). NXP does not accept any liability in this respect.

Limiting values — Stress above one or more limiting values (as defined in the Absolute Maximum Ratings System of IEC 60134) will cause permanent damage to the device. Limiting values are stress ratings only and (proper) operation of the device at these or any other conditions above those given in the Recommended operating conditions section (if present) or the Characteristics sections of this document is not warranted. Constant or repeated exposure to limiting values will permanently and irreversibly affect the quality and reliability of the device.

Terms and conditions of commercial sale — NXP Semiconductors products are sold subject to the general terms and conditions of commercial sale, as published at <http://www.nxp.com/profile/terms>, unless otherwise agreed in a valid written individual agreement. In case an individual agreement is concluded only the terms and conditions of the respective agreement shall apply. NXP Semiconductors hereby expressly objects to applying the customer's general terms and conditions with regard to the purchase of NXP Semiconductors products by customer.

No offer to sell or license — Nothing in this document may be interpreted or construed as an offer to sell products that is open for acceptance or the grant, conveyance or implication of any license under any copyrights, patents or other industrial or intellectual property rights.

Export control — This document as well as the item(s) described herein may be subject to export control regulations. Export might require a prior authorization from competent authorities.

Translations — A non-English (translated) version of a document is for reference only. The English version shall prevail in case of any discrepancy between the translated and English versions.

18.4 Trademarks

Notice: All referenced brands, product names, service names and trademarks are the property of their respective owners.

19. Contact information

For more information, please visit: <http://www.nxp.com>

For sales office addresses, please send an email to: salesaddresses@nxp.com

20. Contents

1 General description 1

2 Features and benefits 1

3 Applications 2

4 Ordering information 2

5 Marking 2

6 Functional diagram 3

7 Pinning information 4

7.1 Pinning 4

7.2 Pin description 5

8 Functional description 5

9 Limiting values 6

10 Recommended operating conditions 6

11 Static characteristics 7

12 Dynamic characteristics 9

13 Waveforms 13

14 Application information 15

14.1 Applications 15

14.2 Architecture 15

14.3 Input driver requirements 16

14.4 Output load considerations 16

14.5 Power-up 16

14.6 Enable and disable 16

14.7 Pull-up or pull-down resistors on I/Os lines . . 17

15 Package outline 18

16 Abbreviations 21

17 Revision history 21

18 Legal information 22

18.1 Data sheet status 22

18.2 Definitions 22

18.3 Disclaimers 22

18.4 Trademarks 23

19 Contact information 23

20 Contents 24

Please be aware that important notices concerning this document and the product(s) described herein, have been included in section 'Legal information'.

© NXP B.V. 2013. All rights reserved.

For more information, please visit: <http://www.nxp.com>
 For sales office addresses, please send an email to: salesaddresses@nxp.com

Date of release: 23 May 2013
 Document identifier: NTS0104_Q100

Looking for pricing, stock, or lifecycle information?

Click below to explore more details on WIN SOURCE:

 [View NTS0104PW-Q100J on WIN SOURCE](#)

 [NXP / Nexperia Information](#)

Optimize Your Supply Chain with WIN SOURCE Solutions

-  Global Sourcing Solution
-  Obsolete Management
-  Cost Control Management
-  Shortage Management
-  Alternative Solution
-  Excess Inventory Management