



**THE DATASHEET OF
NLVLVX4245DTR2G**



Dual Supply Octal Translating Transceiver

with 3-State Outputs

MC74LVX4245

The 74LVX4245 is a 24-pin dual-supply, octal translating transceiver that is designed to interface between a 5.0 V bus and a 3.0 V bus in a mixed 3.0 V / 5.0 V supply environment such as laptop computers using a 3.3 V CPU and 5.0 V LCD display. The A port interfaces with the 5V bus; the B port interfaces with the 3.0 V bus.

The Transmit/Receive (T/R) input determines the direction of data flow. Transmit (active-High) enables data from the A port to the B port. Receive (active-Low) enables data from the B port to the A port. The Output Enable (\overline{OE}) input, when High, disables both A and B ports by placing them in 3-State.

Features

- Bi-directional Interface Between 5.0 V and 3.0 V Buses
- Control Inputs Compatible with TTL Level
- 5.0 V Data Flow at A Port and 3.0 V Data Flow at B Port
- Outputs Source/Sink 24 mA at 5.0 V Bus and 12 mA at 3.0 V Bus
- Guaranteed Simultaneous Switching Noise Level and Dynamic Threshold Performance
- Available in SOIC and TSSOP Packages
- Functionally Compatible with the 74 Series 245
- NLV Prefix for Automotive and Other Applications Requiring Unique Site and Control Change Requirements; AEC-Q100 Qualified and PPAP Capable
- These Devices are Pb-Free, Halogen Free/BFR Free and are RoHS Compliant

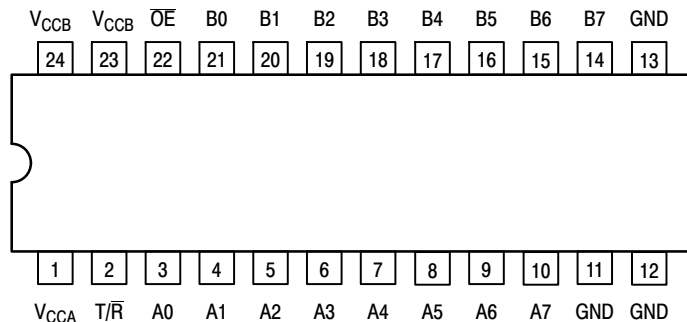
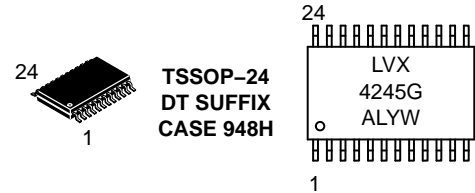
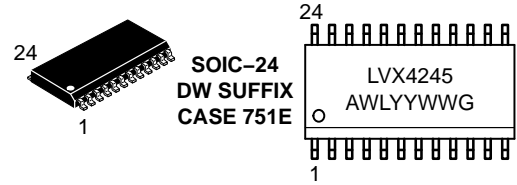

Figure 1. 24-Lead Pinout (Top View)

MARKING DIAGRAMS



LVX4245 = Specific Device Code
A = Assembly Location
WL, L = Wafer Lot
Y = Year
WW, W = Work Week
G or ■ = Pb-Free Package

(Note: Microdot may be in either location)

PIN NAMES

Pins	Function
\overline{OE}	Output Enable Input
T/R	Transmit/Receive Input
A0-A7	Side A 3-State Inputs or 3-State Outputs
B0-B7	Side B 3-State Inputs or 3-State Outputs

ORDERING INFORMATION

See detailed ordering and shipping information in the package dimensions section on page 5 of this data sheet.

NOTE: Some of the devices on this data sheet have been **DISCONTINUED**. Please refer to the table on page 5.

MC74LVX4245

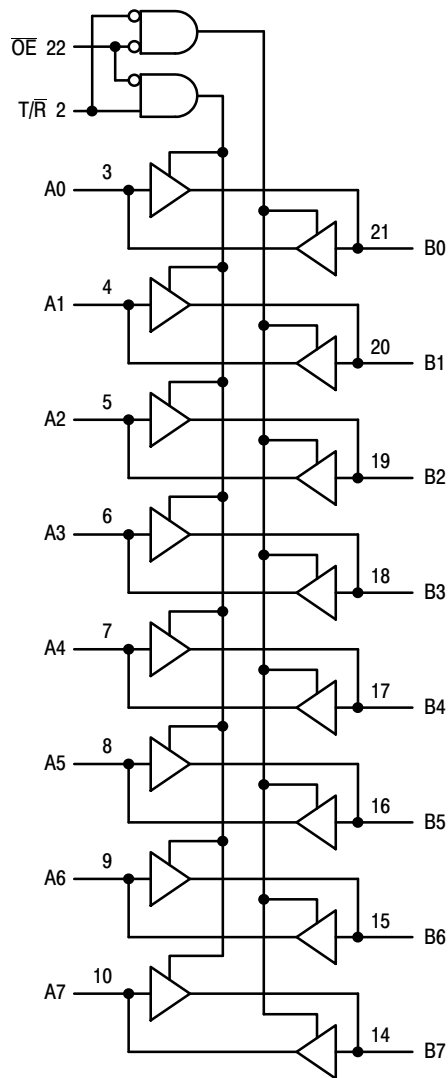

Figure 2. Logic Diagram

INPUTS		OPERATING MODE Non-Inverting
OE	T/R	
L	L	B Data to A Bus
L	H	A Data to B Bus
H	X	Z

H = High Voltage Level; L = Low Voltage Level; Z = High Impedance State; X = High or Low Voltage Level and Transitions are Acceptable; For I_{CC} reasons, Do Not Float Inputs

MC74LVX4245

ABSOLUTE MAXIMUM RATINGS

Symbol	Parameter	Value	Condition	Unit
V_{CCA}, V_{CCB}	DC Supply Voltage	-0.5 to +7.0		V
V_I	DC Input Voltage $\overline{OE}, T/R$	-0.5 to $V_{CCA} + 0.5$		V
$V_{I/O}$	DC Input/Output Voltage	An	-0.5 to $V_{CCA} + 0.5$	V
		Bn	-0.5 to $V_{CCB} + 0.5$	V
I_{IK}	DC Input Diode Current $\overline{OE}, T/R$	± 20	$V_I < GND$	mA
I_{OK}	DC Output Diode Current	± 50	$V_O < GND; V_O > V_{CC}$	mA
I_O	DC Output Source/Sink Current	± 50		mA
I_{CC}, I_{GND}	DC Supply Current Per Output Pin Maximum Current at I_{CCA} Maximum Current at I_{CCB}	± 50 ± 200 ± 100		mA
T_{STG}	Storage Temperature Range	-65 to +150		$^{\circ}C$
Latchup	DC Latchup Source/Sink Current	± 300		mA

Stresses exceeding those listed in the Maximum Ratings table may damage the device. If any of these limits are exceeded, device functionality should not be assumed, damage may occur and reliability may be affected.

RECOMMENDED OPERATING CONDITIONS

Symbol	Parameter	Min	Max	Unit
V_{CCA}, V_{CCB}	Supply Voltage V_{CCA} V_{CCB}	4.5 2.7	5.5 3.6	V
V_I	Input Voltage $\overline{OE}, T/R$	0	V_{CCA}	V
$V_{I/O}$	Input/Output Voltage An Bn	0	V_{CCA}	V
		0	V_{CCB}	V
T_A	Operating Free-Air Temperature	-40	+85	$^{\circ}C$
$\Delta t/\Delta V$	Minimum Input Edge Rate V_{IN} from 30% to 70% of V_{CC} ; V_{CC} at 3.0V, 4.5V, 5.5V	0	8	ns/V

Functional operation above the stresses listed in the Recommended Operating Ranges is not implied. Extended exposure to stresses beyond the Recommended Operating Ranges limits may affect device reliability.

DC ELECTRICAL CHARACTERISTICS

Symbol	Parameter	Condition	V_{CCA}	V_{CCB}	$T_A = 25^{\circ}C$		$T_A = -40 \text{ to } +85^{\circ}C$		Unit
					Typ	Guaranteed Limits			
V_{IHA}	Minimum HIGH Level Input Voltage	$V_{OUT} \leq 0.1V$ or $\geq V_{CC} - 0.1V$	5.5	3.3		2.0	2.0	V	
			4.5	3.3		2.0	2.0		
V_{IHB}	Input Voltage	$V_{OUT} \leq 0.1V$ or $\geq V_{CC} - 0.1V$	5.0	3.6		2.0	2.0	V	
			5.0	2.7		2.0	2.0		
V_{ILA}	Maximum LOW Level Input Voltage	$V_{OUT} \leq 0.1V$ or $\geq V_{CC} - 0.1V$	5.5	3.3		0.8	0.8	V	
			4.5	3.3		0.8	0.8		
V_{ILB}	Input Voltage	$V_{OUT} \leq 0.1V$ or $\geq V_{CC} - 0.1V$	5.0	2.7		0.8	0.8	V	
			5.0	3.6		0.8	0.8		
V_{OHA}	Minimum HIGH Level Output Voltage	$I_{OUT} = -100\mu A$ $I_{OH} = -24mA$	4.5	3.0	4.50	4.40	4.40	V	
			4.5	3.0	4.25	3.86	3.76		
V_{OHB}	Output Voltage	$I_{OUT} = -100\mu A$ $I_{OH} = -12mA$ $I_{OH} = -8mA$	4.5	3.0	2.99	2.9	2.9	V	
			4.5	3.0	2.80	2.4	2.4		
			4.5	2.7	2.50	2.4	2.4		
V_{OLA}	Maximum LOW Level Output Voltage	$I_{OUT} = 100\mu A$ $I_{OL} = 24mA$	4.5	3.0	0.002	0.10	0.10	V	
			4.5	3.0	0.18	0.36	0.44		
V_{OLB}	Output Voltage	$I_{OUT} = 100\mu A$ $I_{OL} = 12mA$ $I_{OL} = 8mA$	4.5	3.0	0.002	0.10	0.10	V	
			4.5	3.0	0.1	0.31	0.40		
			4.5	2.7	0.1	0.31	0.40		

MC74LVX4245

DC ELECTRICAL CHARACTERISTICS

Symbol	Parameter	Condition	V _{CCA}	V _{CCB}	T _A = 25°C		T _A = -40 to +85°C		Unit
					Typ	Guaranteed Limits			
I _{IN}	Max Input Leakage Current	$\overline{OE}, T/\overline{R}$ V _I = V _{CCA} , GND	5.5	3.6		±0.1	±1.0		μA
I _{OZA}	Max 3-State Output Leakage	An V _I = V _{IH} , V _{IL} OE = V _{CCA} V _O = V _{CCA} , GND	5.5	3.6		±0.5	±5.0		μA
I _{OZB}	Max 3-State Output Leakage	Bn V _I = V _{IH} , V _{IL} OE = V _{CCA} V _O = V _{CCB} , GND	5.5	3.6		±0.5	±5.0		μA
ΔI _{CC}	Maximum I _{CC} T per Input	An, OE T/R	V _I =V _{CCA} -2.1V	5.5	3.6	1.0	1.35	1.5	mA
		Bn	V _I =V _{CCB} -0.6V	5.5	3.6		0.35	0.5	mA
I _{CCA}	Quiescent V _{CCA} Supply Current	An=V _{CCA} or GND Bn=V _{CCB} or GND OE=GND T/R=GND	5.5	3.6		8	80		μA
I _{CCB}	Quiescent V _{CCB} Supply Current	An=V _{CCA} or GND Bn=V _{CCB} or GND OE=GND T/R=V _{CCA}	5.5	3.6		5	50		μA
V _{OLPA} V _{OLPB}	Quiet Output Max Dynamic V _{OL}	Notes 1, 2	5.0 5.0	3.3 3.3		1.5 1.2			V
V _{OLVA} V _{OLVB}	Quiet Output Min Dynamic V _{OL}	Notes 1, 2	5.0 5.0	3.3 3.3		-1.2 -0.8			V
V _{IHDA} V _{IHDB}	Min HIGH Level Dynamic Input Voltage	Notes 1, 3	5.0 5.0	3.3 3.3		2.0 2.0			V
V _{ILDA} V _{ILDB}	Max LOW Level Dynamic Input Voltage	Notes 1, 3	5.0 5.0	3.3 3.3		0.8 0.8			V

Product parametric performance is indicated in the Electrical Characteristics for the listed test conditions, unless otherwise noted. Product performance may not be indicated by the Electrical Characteristics if operated under different conditions.

1. Worst case package.
2. Max number of outputs defined as (n). Data inputs are driven 0V to V_{CC} level; one output at GND.
3. Max number of data inputs (n) switching. (n-1) inputs switching 0V to V_{CC} level. Input under test switching: V_{CC} level to threshold (V_{IHD}), 0V to threshold (V_{ILD}), f = 1MHz.

CAPACITIVE CHARACTERISTICS

Symbol	Parameter	Condition	Typical	Unit
C _{IN}	Input Capacitance	V _{CCA} = 5.0V; V _{CCB} = 3.3V	4.5	pF
C _{I/O}	Input/Output Capacitance	V _{CCA} = 5.0V; V _{CCB} = 3.3V	15	pF
C _{PD}	Power Dissipation Capacitance (Measured at 10MHz)	B→A	V _{CCA} = 5.0V	55
		A→B	V _{CCB} = 3.3V	40

MC74LVX4245

AC ELECTRICAL CHARACTERISTICS

Symbol	Parameter	$T_A = -40 \text{ to } +85^\circ\text{C}$ $C_L = 50\text{pF}$			$T_A = -40 \text{ to } +85^\circ\text{C}$ $C_L = 50\text{pF}$		Unit
		$V_{CCA} = 5V \pm 0.5V$ $V_{CCB} = 3.3V \pm 0.3V$			$V_{CCA} = 5V \pm 0.5V$ $V_{CCB} = 2.7V$		
		Min	Typ (Note 4)	Max	Min	Max	
t_{PHL} t_{PLH}	Propagation Delay A to B	1.0 1.0	5.1 5.3	9.0 9.0	1.0 1.0	10.0 10.0	ns
t_{PHL} t_{PLH}	Propagation Delay B to A	1.0 1.0	5.4 5.5	9.0 9.0	1.0 1.0	10.0 10.0	ns
t_{PZL} t_{PZH}	Output Enable Time \overline{OE} to B	1.0 1.0	6.5 6.7	10.5 10.5	1.0 1.0	11.5 11.5	ns
t_{PZL} t_{PZH}	Output Enable Time \overline{OE} to A	1.0 1.0	5.2 5.8	9.5 9.5	1.0 1.0	10.0 10.0	ns
t_{PHZ} t_{PLZ}	Output Disable Time \overline{OE} to B	1.0 1.0	6.0 3.3	10.0 7.0	1.0 1.0	10.0 7.5	ns
t_{PHZ} t_{PLZ}	Output Disable Time \overline{OE} to A	1.0 1.0	3.9 2.9	7.5 7.0	1.0 1.0	7.5 7.5	ns
t_{OSHL} t_{OSLH}	Output to Output Skew, Data to Output (Note 5)		1.0	1.5		1.5	ns

4. Typical values at $V_{CCA} = 5.0V$; $V_{CCB} = 3.3V$ at 25°C .

5. Skew is defined as the absolute value of the difference between the actual propagation delay for any two separate outputs of the same device. The specification applies to any outputs switching in the same direction, either HIGH-to-LOW (t_{OSHL}) or LOW-to-HIGH (t_{OSLH}); parameter guaranteed by design.

ORDERING INFORMATION

Device	Package	Shipping†
MC74LVX4245DWR2G	SOIC-24 (Pb-Free)	1000 / Tape & Reel
MC74LVX4245DTR2G	TSSOP-24 (Pb-Free)	2500 / Tape & Reel

DISCONTINUED (Note 6)

MC74LVX4245DWG	SOIC-24 (Pb-Free)	30 Units / Rail
MC74LVX4245DTG	TSSOP-24 (Pb-Free)	62 Units / Rail
NLVLVX4245DTR2G*		2500 / Tape & Reel

†For information on tape and reel specifications, including part orientation and tape sizes, please refer to our Tape and Reel Packaging Specifications Brochure, BRD8011/D.

*NLV Prefix for Automotive and Other Applications Requiring Unique Site and Control Change Requirements; AEC-Q100 Qualified and PPAP Capable.

6. **DISCONTINUED:** These devices are not recommended for new design. Please contact your onsemi representative for information. The most current information on these devices may be available on www.onsemi.com.

Dual Supply Octal Translating Transceiver

The 74LVX4245 is a dual-supply device well capable of bidirectional signal voltage translation. This level shifting ability provides an excellent interface between low voltage CPU local bus and a standard 5.0 V I/O bus. The device control inputs can be controlled by either the low voltage CPU and core logic or a bus arbitrator with 5.0 V I/O levels.

The LVX4245 is ideal for mixed voltage applications such as notebook computers using a 3.3 V CPU and 5.0 V peripheral devices.

Applications:

Mixed Mode Dual Supply Interface Solutions

The LVX4245 is designed to solve 3.0 V / 5.0 V interfaces when CMOS devices cannot tolerate I/O levels above their applied V_{CC} . If an I/O pin of a 3.0 V device is driven by a 5.0 V device, the P-Channel transistor in the 3.0 V device will conduct – causing current flow from the I/O bus to the 3.0 V power supply. The result may be destruction of the 3.0 V device through latchup effects. A current limiting resistor may be used to prevent destruction, but it causes speed degradation and needless power dissipation.

A better solution is provided in the LVX4245. It provides two different output levels that easily handle the dual voltage interface. The A port is a dedicated 5.0 V port; the B port is a dedicated 3.0 V port.

Since the LVX4245 is a '245 transceiver, the user may either use it for bidirectional or unidirectional applications. The center 20 pins are configured to match a '245 pinout. This enables the user to easily replace this level shifter with a 3.0 V '245 device without additional layout work or re-manufacture of the circuit board (when both buses are 3.0 V).

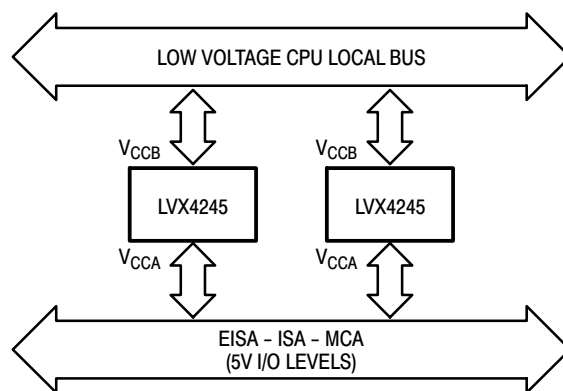

Figure 3. 3.3V/5V Interface Block Diagram

Powering Up the LVX4245

When powering up the LVX4245, please note that if the V_{CCB} pin is powered-up well in advance of the V_{CCA} pin, several milliamps of either I_{CCA} or I_{CCB} current will result. If the V_{CCA} pin is powered-up in advance of the V_{CCB} pin then only nanoamps of I_{CC} current will result. In actuality the V_{CCB} can be powered “slightly” before the V_{CCA} without the current penalty, but this “setup time” is dependent on the power-up ramp rate of the V_{CC} pins. With a ramp rate of approximately 50 mV/ns (50V/ μ s) a 25 ns setup time was observed (V_{CCB} before V_{CCA}). With a 7.0 V/ μ s rate, the setup time was about 140ns. When all is said and done, the safest powerup strategy is to simply power V_{CCA} before V_{CCB} . One more note: if the V_{CCB} ramp rate is faster than the V_{CCA} ramp rate then power problems might still occur, even if the V_{CCA} powerup began prior to the V_{CCB} powerup.

MC74LVX4245

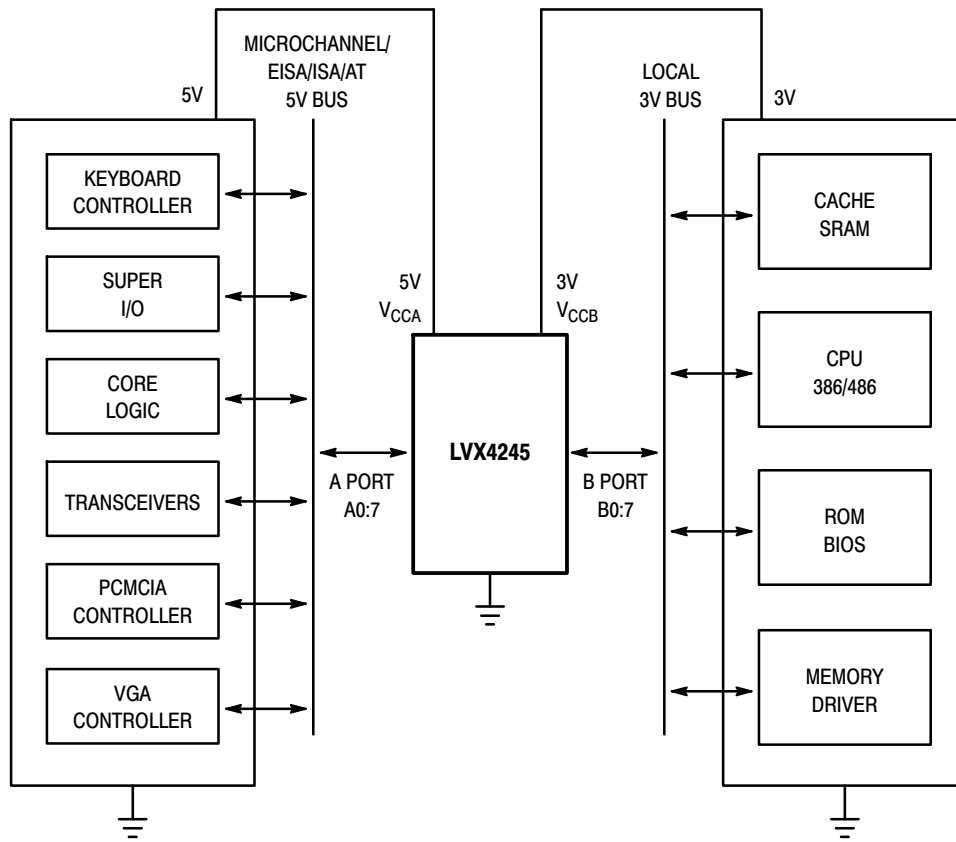

Figure 4. MC74LVX4245 Fits Into a System with 3V Subsystem and 5V Subsystem

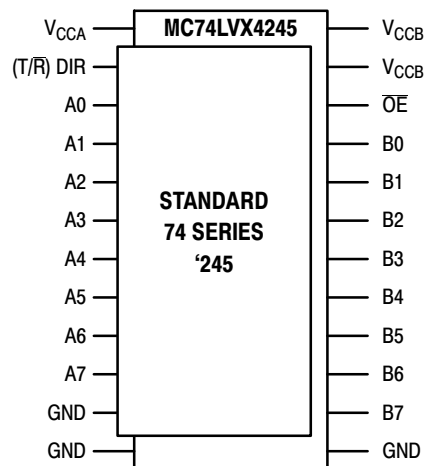
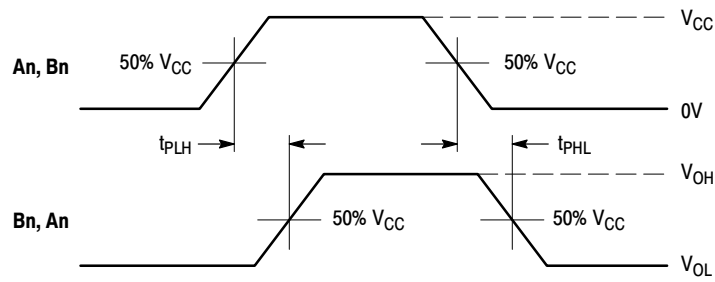
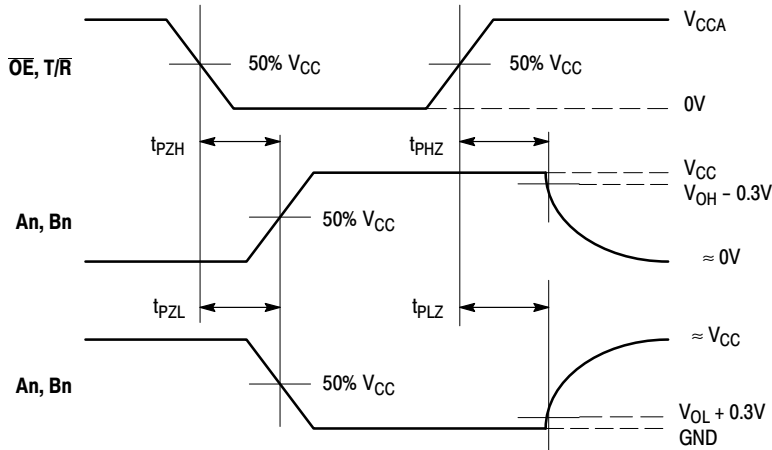

Figure 5. MC74LVX4245 Pin Arrangement Is Compatible to 20-Pin 74 Series '245s

MC74LVX4245



WAVEFORM 1 - PROPAGATION DELAYS
 $t_R = t_F = 2.5\text{ns}$, 10% to 90%; $f = 1\text{MHz}$; $t_W = 500\text{ns}$



WAVEFORM 2 - OUTPUT ENABLE AND DISABLE TIMES
 $t_R = t_F = 2.5\text{ns}$, 10% to 90%; $f = 1\text{MHz}$; $t_W = 500\text{ns}$

Figure 6. AC Waveforms

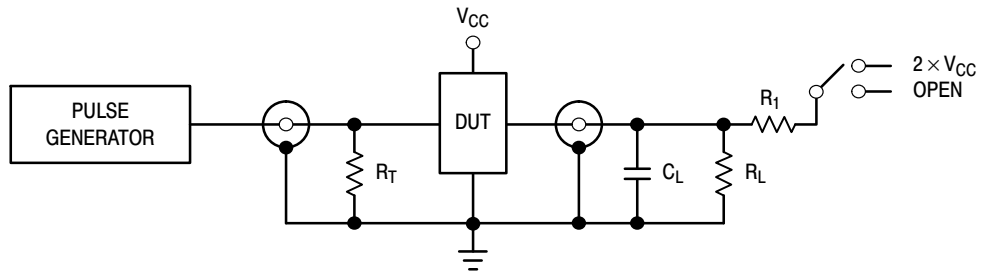

TEST	SWITCH
t_{PLH} , t_{PHL} , t_{PZH} , t_{PHZ}	Open
t_{PZL} , t_{PLZ}	$2 \times V_{CC}$

$C_L = 50\text{pF}$ or equivalent (Includes jig and probe capacitance)
 $R_L = R_1 = 500\Omega$ or equivalent
 $R_T = Z_{OUT}$ of pulse generator (typically 50Ω)

Figure 7. Test Circuit

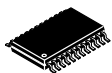

SCALE 1:1

TSSOP24 7.8x4.4, 0.65P
CASE 948H
ISSUE B

DATE 21 JUN 2012

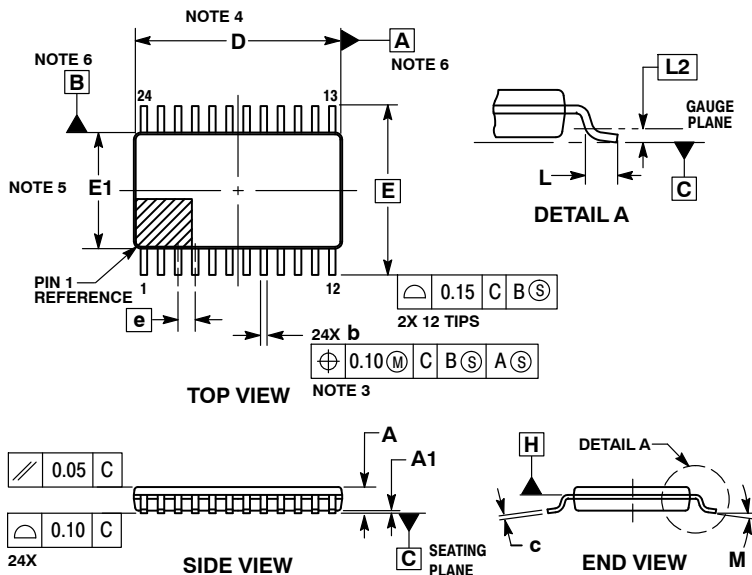

- NOTES:
1. DIMENSIONING AND TOLERANCING PER ASME Y14.5M, 1994.
 2. CONTROLLING DIMENSION: MILLIMETERS.
 3. DIMENSION *b* DOES NOT INCLUDE DAMBAR PROTRUSION. DAMBAR PROTRUSION SHALL BE 0.08 MAX AT MMC. DAMBAR CANNOT BE LOCATED ON THE LOWER RADIUS OF THE FOOT.
 4. DIMENSION *D* DOES NOT INCLUDE MOLD FLASH, PROTRUSIONS OR GATE BURRS. MOLD FLASH, PROTRUSIONS OR GATE BURRS SHALL NOT EXCEED 0.15 PER SIDE. DIMENSION *D* IS DETERMINED AT DATUM PLANE H.
 5. DIMENSION *E1* DOES NOT INCLUDE INTERLEAD FLASH OR PROTRUSION. INTERLEAD FLASH OR PROTRUSION SHALL NOT EXCEED 0.25 PER SIDE. DIMENSION *E1* IS DETERMINED AT DATUM PLANE H.
 6. DATUMS A AND B ARE DETERMINED AT DATUM PLANE H.
 7. A1 IS DEFINED AS THE VERTICAL DISTANCE FROM THE SEATING PLANE TO THE LOWEST POINT ON THE PACKAGE BODY.

DIM	MILLIMETERS	
	MIN	MAX
A	---	1.20
A1	0.05	0.15
<i>b</i>	0.19	0.30
<i>c</i>	0.09	0.20
D	7.70	7.90
E	6.40 BSC	
E1	4.30	4.50
<i>e</i>	0.65 BSC	
L	0.50	0.75
L2	0.25 BSC	
M	0°	8°

GENERIC MARKING DIAGRAM*

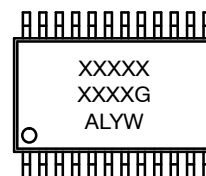

- XXXX = Specific Device Code
- A = Assembly Location
- L = Wafer Lot
- Y = Year
- W = Work Week
- G = Pb-Free Package

RECOMMENDED SOLDERING FOOTPRINT*

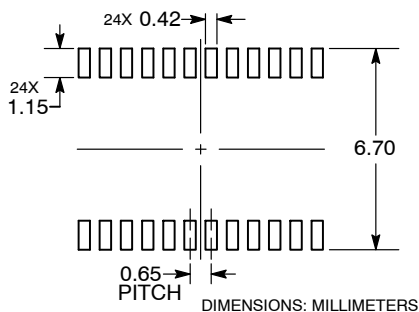

*For additional information on our Pb-Free strategy and soldering details, please download the onsemi Soldering and Mounting Techniques Reference Manual, SOLDERRM/D.

*This information is generic. Please refer to device data sheet for actual part marking. Pb-Free indicator, "G" or microdot "▪", may or may not be present. Some products may not follow the Generic Marking.

DOCUMENT NUMBER:	98ASH70248A	Electronic versions are uncontrolled except when accessed directly from the Document Repository. Printed versions are uncontrolled except when stamped "CONTROLLED COPY" in red.
DESCRIPTION:	TSSOP24 7.8X4.4, 0.65P	PAGE 1 OF 1

onsemi and ONSEMI are trademarks of Semiconductor Components Industries, LLC dba onsemi or its subsidiaries in the United States and/or other countries. onsemi reserves the right to make changes without further notice to any products herein. onsemi makes no warranty, representation or guarantee regarding the suitability of its products for any particular purpose, nor does onsemi assume any liability arising out of the application or use of any product or circuit, and specifically disclaims any and all liability, including without limitation special, consequential or incidental damages. onsemi does not convey any license under its patent rights nor the rights of others.

onsemi, **Onsemi**, and other names, marks, and brands are registered and/or common law trademarks of Semiconductor Components Industries, LLC dba "**onsemi**" or its affiliates and/or subsidiaries in the United States and/or other countries. **onsemi** owns the rights to a number of patents, trademarks, copyrights, trade secrets, and other intellectual property. A listing of **onsemi**'s product/patent coverage may be accessed at www.onsemi.com/site/pdf/Patent-Marking.pdf. **onsemi** reserves the right to make changes at any time to any products or information herein, without notice. The information herein is provided "as-is" and **onsemi** makes no warranty, representation or guarantee regarding the accuracy of the information, product features, availability, functionality, or suitability of its products for any particular purpose, nor does **onsemi** assume any liability arising out of the application or use of any product or circuit, and specifically disclaims any and all liability, including without limitation special, consequential or incidental damages. Buyer is responsible for its products and applications using **onsemi** products, including compliance with all laws, regulations and safety requirements or standards, regardless of any support or applications information provided by **onsemi**. "Typical" parameters which may be provided in **onsemi** data sheets and/or specifications can and do vary in different applications and actual performance may vary over time. All operating parameters, including "Typicals" must be validated for each customer application by customer's technical experts. **onsemi** does not convey any license under any of its intellectual property rights nor the rights of others. **onsemi** products are not designed, intended, or authorized for use as a critical component in life support systems or any FDA Class 3 medical devices or medical devices with a same or similar classification in a foreign jurisdiction or any devices intended for implantation in the human body. Should Buyer purchase or use **onsemi** products for any such unintended or unauthorized application, Buyer shall indemnify and hold **onsemi** and its officers, employees, subsidiaries, affiliates, and distributors harmless against all claims, costs, damages, and expenses, and reasonable attorney fees arising out of, directly or indirectly, any claim of personal injury or death associated with such unintended or unauthorized use, even if such claim alleges that **onsemi** was negligent regarding the design or manufacture of the part. **onsemi** is an Equal Opportunity/Affirmative Action Employer. This literature is subject to all applicable copyright laws and is not for resale in any manner.

ADDITIONAL INFORMATION

TECHNICAL PUBLICATIONS:

Technical Library: www.onsemi.com/design/resources/technical-documentation
onsemi Website: www.onsemi.com

ONLINE SUPPORT: www.onsemi.com/support

For additional information, please contact your local Sales Representative at www.onsemi.com/support/sales

Looking for pricing, stock, or lifecycle information?

Click below to explore more details on WIN SOURCE:

- ⊖ [View NLVLVX4245DTR2G on WIN SOURCE](#)
- ⊖ [ON Semiconductor](#) Information

Optimize Your Supply Chain with WIN SOURCE Solutions

- ✓ Global Sourcing Solution
- ✓ Obsolete Management
- ✓ Cost Control Management
- ✓ Shortage Management
- ✓ Alternative Solution
- ✓ Excess Inventory Management