



**THE DATASHEET OF
ADG1309BRUZ-REEL7**



FEATURES

33 V supply range
130 Ω on resistance
Fully specified at ±15 V/+12 V
3 V logic-compatible inputs
Rail-to-rail operation
Break-before-make switching action
16-lead TSSOP and 16-lead SOIC_N
Upgrade for the ADG508A/ADG509A

APPLICATIONS

Audio and video routing
Test equipment
Data acquisition systems
Battery-powered systems
Communication systems
Signal routing

FUNCTIONAL BLOCK DIAGRAMS

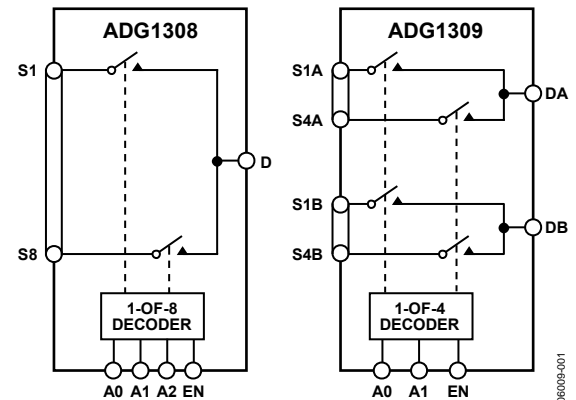

Figure 1.

GENERAL DESCRIPTION

The ADG1308 and ADG1309 are monolithic analog multiplexers consisting of eight single channels and four differential channels, respectively. The ADG1308 switches one of eight inputs to a common output as determined by the 3-bit binary address lines A0, A1, and A2. The ADG1309 switches one of four differential inputs to a common differential output as determined by the 2-bit binary address lines A0 and A1. An EN input on both devices is used to enable or disable the device. When disabled, all channels are switched off.

When the switches are on, each switch conducts equally well in both directions and has an input signal range that extends to the power supplies. In the off condition, signal levels up to the supplies are blocked. All switches exhibit break-before-make switching action for use in multiplexer applications. Inherent in the design is the low charge injection for minimum transients when switching the digital inputs.

Fast switching speed coupled with high signal bandwidth makes the parts suitable for video signal switching. CMOS construction ensures ultra low power dissipation, making the parts ideally suited for portable and battery-powered instruments.

PRODUCT HIGHLIGHTS

1. 16-lead TSSOP and 16-lead SOIC_N available.
2. Pin compatible with the ADG508AKR and the ADG509AKR devices.
3. 3 V, logic-compatible digital input where:
 $V_{IH} = 2.0 \text{ V}$ and $V_{IL} = 0.8 \text{ V}$.
4. V_L logic power supply not required.
5. Low power consumption.

Rev. A

Information furnished by Analog Devices is believed to be accurate and reliable. However, no responsibility is assumed by Analog Devices for its use, nor for any infringements of patents or other rights of third parties that may result from its use. Specifications subject to change without notice. No license is granted by implication or otherwise under any patent or patent rights of Analog Devices. Trademarks and registered trademarks are the property of their respective owners.

TABLE OF CONTENTS

Features	1	Absolute Maximum Ratings	6
Applications.....	1	ESD Caution.....	6
Functional Block Diagrams.....	1	Pin Configurations and Function Descriptions	7
General Description	1	ADG1308 Truth Table	7
Product Highlights	1	ADG1309 Truth Table	8
Revision History	2	Typical Performance Characteristics	9
Specifications.....	3	Test Circuits.....	11
Dual Supply	3	Terminology	13
Single Supply	5	Outline Dimensions	14
		Ordering Guide	14

REVISION HISTORY

1/09—Rev. 0 to Rev. A

Change to I_{DD} Parameter, Table 1	4
Change to I_{DD} Parameter, Table 2	5
Updated Outline Dimensions	14

4/06—Revision 0: Initial Version

SPECIFICATIONS

DUAL SUPPLY

$V_{DD} = +15\text{ V} \pm 10\%$, $V_{SS} = -15\text{ V} \pm 10\%$, $GND = 0\text{ V}$, unless otherwise noted.¹

Table 1.

Parameter	+25°C	-40°C to +105°C	Unit	Test Conditions/Comments
ANALOG SWITCH				
Analog Signal Range		V_{SS} to V_{DD}	V	
On Resistance, R_{ON}	130		Ω typ	$V_S = \pm 10\text{ V}$, $I_S = -1\text{ mA}$; see Figure 13
	210	300	Ω max	$V_{DD} = +13.5\text{ V}$, $V_{SS} = -13.5\text{ V}$
On Resistance Match Between Channels, ΔR_{ON}	5		Ω typ	$V_S = \pm 10\text{ V}$, $I_S = -1\text{ mA}$
	10		Ω max	
On Resistance Flatness, R_{FLAT} (On)	25		Ω typ	$V_S = -5\text{ V}, 0\text{ V}, +5\text{ V}$, $I_S = -1\text{ mA}$
	70		Ω max	
LEAKAGE CURRENTS				
Source Off Leakage, I_S (Off)	± 1		nA typ	$V_D = \pm 10\text{ V}$, $V_S = -10\text{ V}$; see Figure 14
		± 50	nA max	
Drain Off Leakage, I_D (Off)	± 1		nA typ	$V_S = 1\text{ V}, 10\text{ V}$; $V_D = 10\text{ V}, 1\text{ V}$; see Figure 14
		± 50	nA max	
Channel On Leakage, I_D, I_S (On)	± 1		nA typ	$V_S = V_D = \pm 10\text{ V}$; see Figure 15
		± 50	nA max	
DIGITAL INPUTS				
Input High Voltage, V_{INH}		2.0	V min	
Input Low Voltage, V_{INL}		0.8	V max	
Input Current, I_{INL} or I_{INH}	± 0.005		μA max	$V_{IN} = V_{INL}$ or V_{INH}
		± 0.1	μA max	
Digital Input Capacitance, C_{IN}	5		pF typ	
DYNAMIC CHARACTERISTICS²				
Transition Time, $t_{TRANSITION}$	80		ns typ	$R_L = 300\ \Omega$, $C_L = 35\text{ pF}$
	130	190	ns max	$V_S = 10\text{ V}$; see Figure 16
t_{ON} (EN)	80		ns typ	$R_L = 300\ \Omega$, $C_L = 35\text{ pF}$
	100	120	ns max	$V_S = 10\text{ V}$; see Figure 18
t_{OFF} (EN)	85		ns typ	$R_L = 300\ \Omega$, $C_L = 35\text{ pF}$
	100	150	ns max	$V_S = 10\text{ V}$; see Figure 18
Break-Before-Make Time Delay, t_{BBM}	25		ns typ	$R_L = 300\ \Omega$, $C_L = 35\text{ pF}$
		10	ns min	$V_{S1} = V_{S2} = 10\text{ V}$; see Figure 17
Charge Injection	2		pC typ	$V_S = 0\text{ V}$, $R_S = 0\ \Omega$, $C_L = 1\text{ nF}$; see Figure 19
Off Isolation	80		dB typ	$R_L = 50\ \Omega$, $C_L = 5\text{ pF}$, $f = 1\text{ MHz}$; see Figure 20
Channel-to-Channel Crosstalk	80		dB typ	$R_L = 50\ \Omega$, $C_L = 5\text{ pF}$, $f = 1\text{ MHz}$; see Figure 21
-3 dB Bandwidth	500		MHz typ	$R_L = 50\ \Omega$, $C_L = 5\text{ pF}$; see Figure 22
C_S (Off)	5		pF typ	$f = 1\text{ MHz}$, $V_S = 0\text{ V}$
C_D (Off)				
ADG1308	15		pF typ	$f = 1\text{ MHz}$, $V_S = 0\text{ V}$
ADG1309	10		pF typ	$f = 1\text{ MHz}$, $V_S = 0\text{ V}$
C_D, C_S (On)				
ADG1308	20		pF typ	$f = 1\text{ MHz}$, $V_S = 0\text{ V}$
ADG1309	15		pF typ	$f = 1\text{ MHz}$, $V_S = 0\text{ V}$

ADG1308/ADG1309

Parameter	+25°C	-40°C to +105°C	Unit	Test Conditions/Comments
POWER REQUIREMENTS				$V_{DD} = +16.5\text{ V}$, $V_{SS} = -16.5\text{ V}$
I_{DD}	0.002		$\mu\text{A typ}$	Digital inputs = 0 V or V_{DD}
		1.0	$\mu\text{A max}$	
I_{DD}	220		$\mu\text{A typ}$	Digital inputs = 5 V
		380	$\mu\text{A max}$	
I_{SS}	0.002		$\mu\text{A typ}$	Digital inputs = 0 V or V_{DD} or 5 V
		1.0	$\mu\text{A max}$	
V_{DD}/V_{SS}		$\pm 5/\pm 16.5$	V min/V max	$ V_{DD} = V_{SS} $

¹ Temperature range for B version is -40°C to +105°C.

² Guaranteed by design; not subject to production test.

SINGLE SUPPLY

$V_{DD} = 12\text{ V}$, $V \pm 10\%$, $V_{SS} = 0\text{ V}$, $GND = 0\text{ V}$, unless otherwise noted.¹

Table 2.

Parameter	+25°C	-40°C to +105°C	Unit	Test Conditions/Comments
ANALOG SWITCH				
Analog Signal Range		0 to V_{DD}	V	
On Resistance, R_{ON}	325		Ω typ	$V_S = 0\text{ V}$ to 10 V , $I_S = -1\text{ mA}$; see Figure 13
	500	660	Ω max	$V_{DD} = 10.8\text{ V}$, $V_{SS} = 0\text{ V}$
On Resistance Match Between Channels, ΔR_{ON}	10		Ω typ	$V_S = 0\text{ V}$ to 10 V , $I_S = -1\text{ mA}$
	20		Ω max	
On Resistance Flatness, R_{FLAT} (On)	65		Ω typ	$V_S = 3\text{ V}$, 6 V , 9 V , $I_S = -1\text{ mA}$
LEAKAGE CURRENTS				
Source Off Leakage, I_S (Off)	± 1		nA typ	$V_{DD} = 13.2\text{ V}$
		± 50	nA max	$V_S = 1\text{ V}/10\text{ V}$, $V_D = 10\text{ V}/1\text{ V}$; see Figure 14
Drain Off Leakage, I_D (Off)	± 1		nA typ	$V_S = 1\text{ V}/10\text{ V}$, $V_D = 10\text{ V}/1\text{ V}$; see Figure 14
		± 50	nA max	
Channel On Leakage, I_D , I_S (On)	± 1		nA typ	$V_S = V_D = 1\text{ V}$ or 10 V ; see Figure 15
		± 50	nA max	
DIGITAL INPUTS				
Input High Voltage, V_{INH}		2.0	V min	
Input Low Voltage, V_{INL}		0.8	V max	
Input Current, I_{INL} or I_{INH}	± 0.001		μA max	$V_{IN} = V_{INL}$ or V_{INH}
		± 0.1	μA max	
Digital Input Capacitance, C_{IN}	3		pF typ	
DYNAMIC CHARACTERISTICS²				
Transition Time, $t_{TRANSITION}$	100		ns typ	$R_L = 300\ \Omega$, $C_L = 35\text{ pF}$
	170	240		$V_S = 8\text{ V}$; see Figure 16
t_{ON} (EN)	90		ns typ	$R_L = 300\ \Omega$, $C_L = 35\text{ pF}$
	110	170		$V_S = 8\text{ V}$; see Figure 18
t_{OFF} (EN)	105		ns typ	$R_L = 300\ \Omega$, $C_L = 35\text{ pF}$
	130	180		$V_S = 8\text{ V}$; see Figure 18
Break-Before-Make Time Delay, t_{BBM}	45		ns typ	$R_L = 300\ \Omega$, $C_L = 35\text{ pF}$
		20	ns min	$V_{S1} = V_{S2} = 8\text{ V}$; see Figure 17
Charge Injection	2		pC typ	$V_S = 6\text{ V}$, $R_S = 0\ \Omega$, $C_L = 1\text{ nF}$; see Figure 19
Off Isolation	80		dB typ	$R_L = 50\ \Omega$, $C_L = 5\text{ pF}$, $f = 1\text{ MHz}$; see Figure 20
Channel-to-Channel Crosstalk	80		dB typ	$R_L = 50\ \Omega$, $C_L = 5\text{ pF}$, $f = 1\text{ MHz}$; see Figure 21
-3 dB Bandwidth	500		MHz typ	$R_L = 50\ \Omega$, $C_L = 5\text{ pF}$; see Figure 22
C_S (Off)	5		pF typ	$f = 1\text{ MHz}$, $V_S = 6\text{ V}$
C_D (Off)				
ADG1308	10		pF typ	$f = 1\text{ MHz}$, $V_S = 6\text{ V}$
ADG1309	15		pF typ	$f = 1\text{ MHz}$, $V_S = 6\text{ V}$
C_D , C_S (On)				
ADG1308	20		pF typ	$f = 1\text{ MHz}$, $V_S = 6\text{ V}$
ADG1309	15		pF typ	$f = 1\text{ MHz}$, $V_S = 6\text{ V}$
POWER REQUIREMENTS				
I_{DD}	0.002		μA typ	$V_{DD} = 13.2\text{ V}$
		1.0	μA max	Digital inputs = 0 V or V_{DD}
I_{DD}	220		μA typ	Digital inputs = 5
		380	μA max	
V_{DD}		5/16.5	V min/V max	$V_{SS} = 0\text{ V}$, $GND = 0\text{ V}$

¹ Temperature range for the B version is -40°C to $+105^\circ\text{C}$.

² Guaranteed by design; not subject to production test.

ABSOLUTE MAXIMUM RATINGS

T_A = 25°C, unless otherwise noted.

Table 3.

Parameter	Rating
V _{DD} to V _{SS}	35 V
V _{DD} to GND	-0.3 V to +25 V
V _{SS} to GND	+0.3 V to -25 V
Analog, Digital Inputs ¹	V _{SS} - 0.3 V to V _{DD} + 0.3 V or 30 mA (whichever occurs first)
Continuous Current, S or D pins	30 mA
Peak Current, S or D pins (Pulsed at 1 ms, 10% Duty Cycle Maximum)	100 mA
Operating Temperature Range	
Industrial (B Version)	-40°C to +105°C
Storage Temperature Range	-65°C to +150°C
Junction Temperature	150°C
TSSOP, θ _{JA} , Thermal Impedance	112°C/W
16-Lead SOIC, θ _{JA} , Thermal Impedance	77°C/W
Reflow Soldering Peak Temperature (Pb-free)	260 (+0/-5)°C

¹ Overvoltages at A, EN, S, or D pins are clamped by internal diodes. Current should be limited to the maximum ratings provided.

Stresses above those listed under Absolute Maximum Ratings may cause permanent damage to the device. This is a stress rating only; functional operation of the device at these or any other conditions above those indicated in the operational section of this specification is not implied. Exposure to absolute maximum rating conditions for extended periods may affect device reliability.

ESD CAUTION

ESD (electrostatic discharge) sensitive device. Electrostatic charges as high as 4000V readily accumulate on the human body and test equipment and can discharge without detection. Although this product features proprietary ESD protection circuitry, permanent damage may occur on devices subjected to high energy electrostatic discharges. Therefore, proper ESD precautions are recommended to avoid performance degradation or loss of functionality.



PIN CONFIGURATIONS AND FUNCTION DESCRIPTIONS

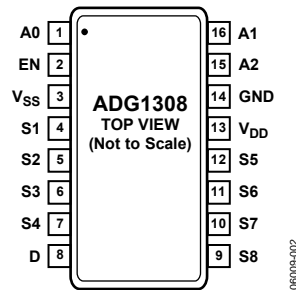

Figure 2. ADG1308 Pin Configuration (TSSOP and SOIC_N)

Table 4. ADG1308 Pin Function Descriptions

Pin Number	Mnemonic	Description
1	A0	Logic Control Input A0.
2	EN	Active High Digital Input. When low, the device is disabled and all switches are off. When high, Ax logic inputs determine on switches.
3	V _{SS}	Most Negative Power Supply Potential. In single supply applications, this pin can be connected to ground.
4	S1	Source Terminal 1. Can be an input or an output.
5	S2	Source Terminal 2. Can be an input or an output.
6	S3	Source Terminal 3. Can be an input or an output.
7	S4	Source Terminal 4. Can be an input or an output.
8	D	Drain Terminal. Can be an input or an output.
9	S8	Source Terminal 8. Can be an input or an output.
10	S7	Source Terminal 7. Can be an input or an output.
11	S6	Source Terminal 6. Can be an input or an output.
12	S5	Source Terminal 5. Can be an input or an output.
13	V _{DD}	Most Positive Power Supply Potential.
14	GND	Ground (0 V) Reference.
15	A2	Logic Control Input A2.
16	A1	Logic Control Input A1.

ADG1308 TRUTH TABLE

Table 5.

A2	A1	A0	EN	ON SWITCH
X ¹	X ¹	X ¹	0	NONE
0	0	0	1	1
0	0	1	1	2
0	1	0	1	3
0	1	1	1	4
1	0	0	1	5
1	0	1	1	6
1	1	0	1	7
1	1	1	1	8

¹ X = Don't care.

ADG1308/ADG1309

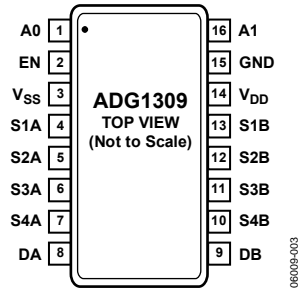

Figure 3. ADG1309 Pin Configuration (TSSOP and SOIC_N)

Table 6. ADG1309 Pin Function Descriptions

Pin Number SOIC/TSSOP	Mnemonic	Description
1	A0	Logic Control Input A0.
2	EN	Active High Digital Input. When low, the device is disabled and all switches are off. When high, Ax logic inputs determine on switches.
3	V _{SS}	Most Negative Power Supply Potential. In single supply applications, this pin can be connected to ground.
4	S1A	Source Terminal 1A. Can be an input or an output.
5	S2A	Source Terminal 2A. Can be an input or an output.
6	S3A	Source Terminal 3A. Can be an input or an output.
7	S4A	Source Terminal 4A. Can be an input or an output.
8	DA	Drain Terminal A. Can be an input or an output.
9	DB	Drain Terminal B. Can be an input or an output.
10	S4B	Source Terminal 4B. Can be an input or an output.
11	S3B	Source Terminal 3B. Can be an input or an output.
12	S2B	Source Terminal 2B. Can be an input or an output.
13	S1B	Source Terminal 1B. Can be an input or an output.
14	V _{DD}	Most Positive Power Supply Potential.
15	GND	Ground (0 V) Reference.
16	A1	Logic Control Input A1.

ADG1309 TRUTH TABLE

Table 7.

AI	A0	EN	ON SWITCH PAIR
X ¹	X ¹	0	NONE
0	0	1	1
0	1	1	2
1	0	1	3
1	1	1	4

¹ X = Don't care.

TYPICAL PERFORMANCE CHARACTERISTICS

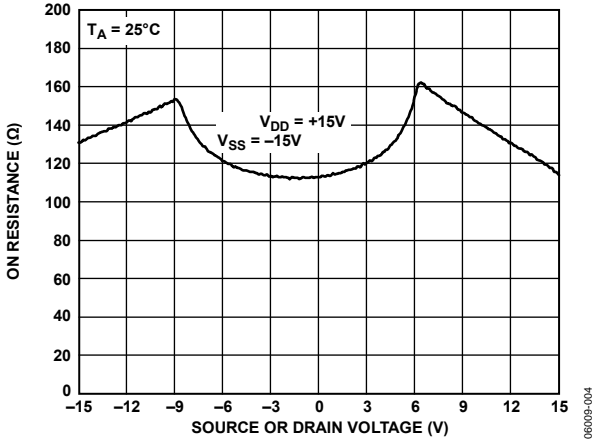

Figure 4. On Resistance as a Function of V_D (V_S) for Dual Supply

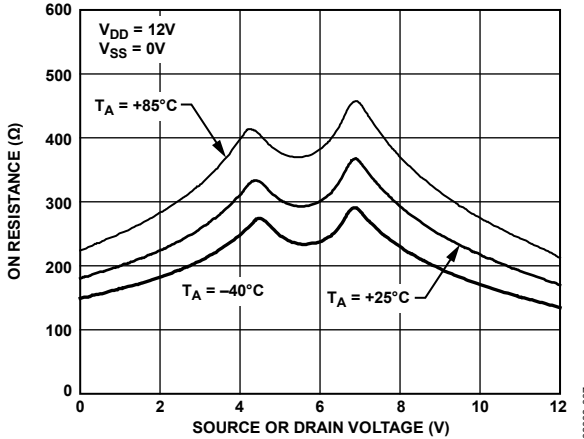

Figure 7. On Resistance as a Function of V_D (V_S) for Different Temperatures, Single Supply

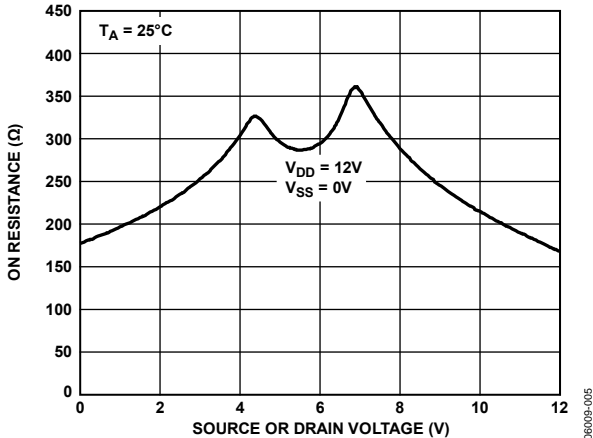

Figure 5. On Resistance as a Function of V_D (V_S) for Single Supply

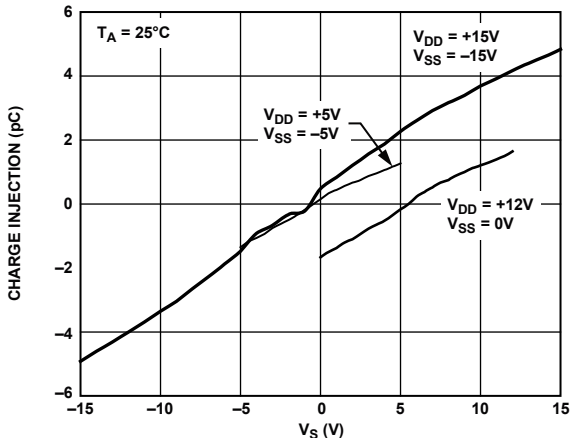

Figure 8. Charge Injection vs. Source Voltage

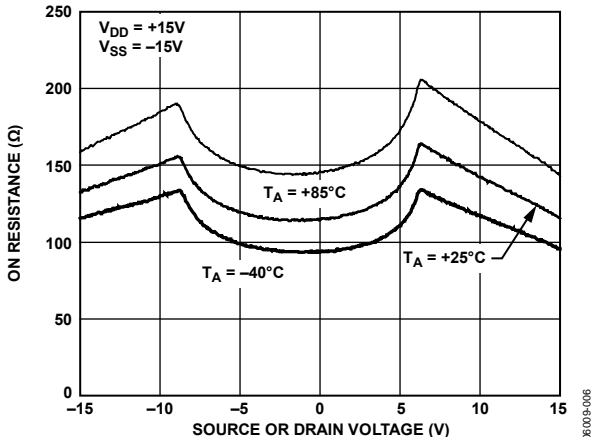

Figure 6. On Resistance as a Function of V_D (V_S) for Different Temperatures, Dual Supply

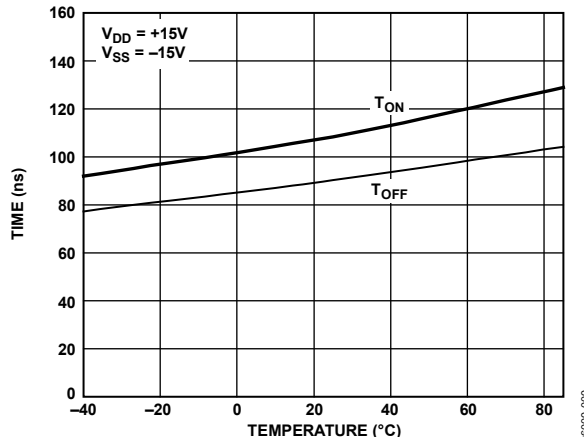
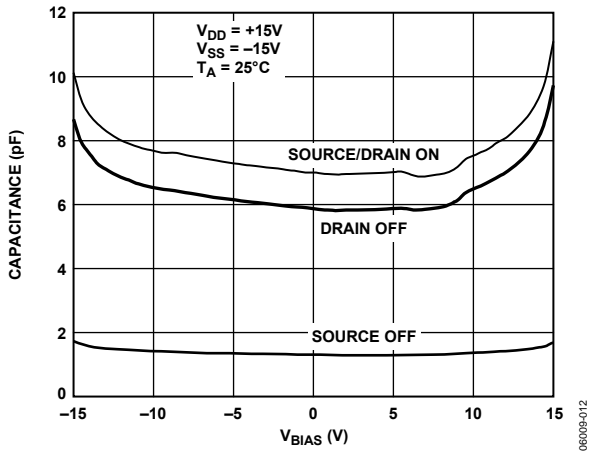
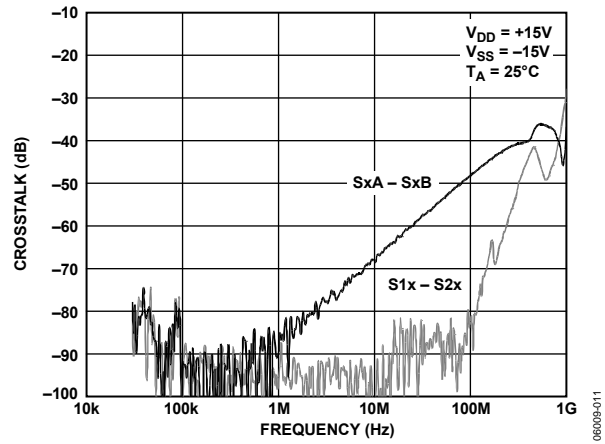
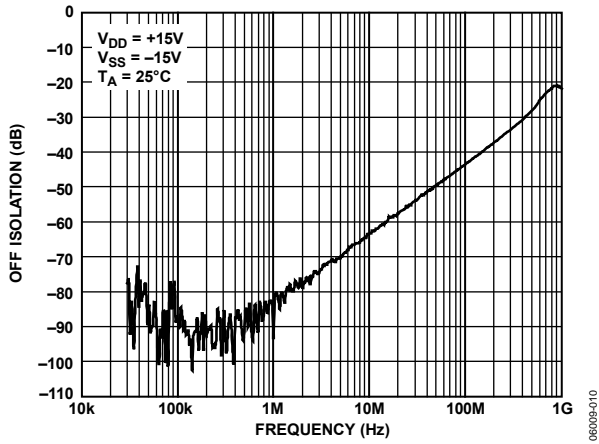

Figure 9. T_{ON}/T_{OFF} Time vs. Temperature

ADG1308/ADG1309



TEST CIRCUITS

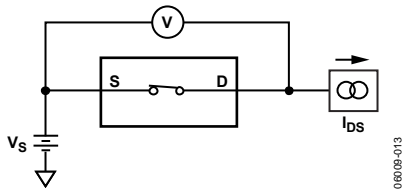

Figure 13. On Resistance

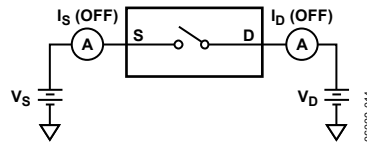

Figure 14. Off Leakage

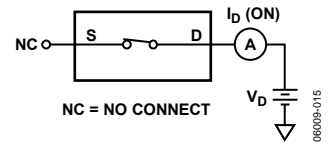

Figure 15. On Leakage

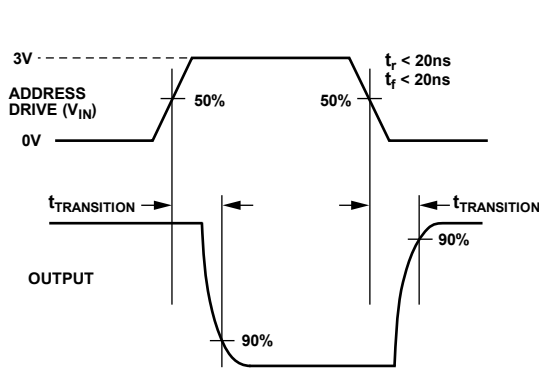
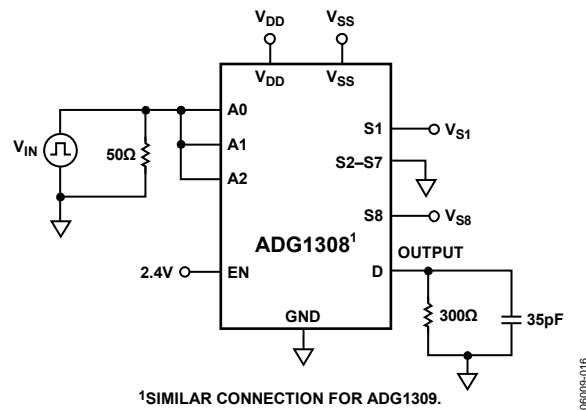

Figure 16. Address to Output Switching Times, $t_{TRANSITION}$



¹SIMILAR CONNECTION FOR ADG1309.

06009-016

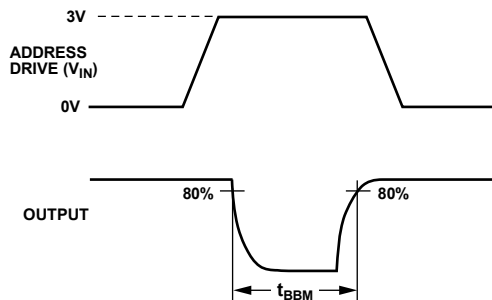
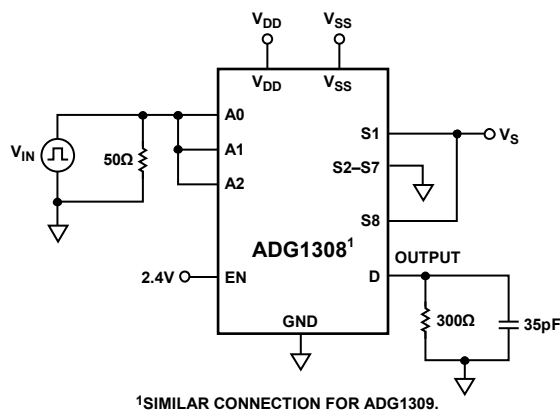

Figure 17. Break-Before-Make Delay, t_{BBM}



¹SIMILAR CONNECTION FOR ADG1309.

06009-017

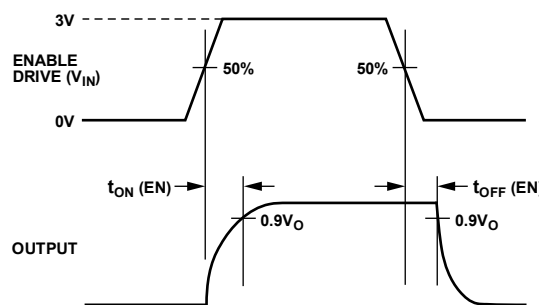
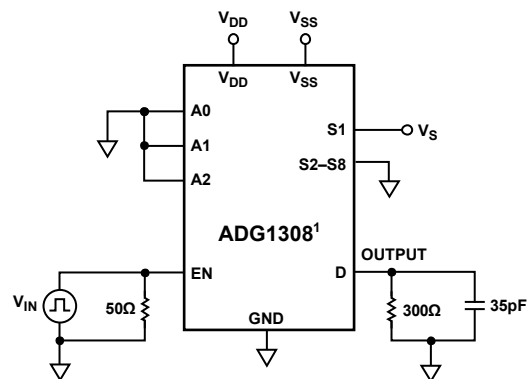

Figure 18. Enable Delay, $t_{ON} (EN)$, $t_{OFF} (EN)$



¹SIMILAR CONNECTION FOR ADG1309.

06009-018

ADG1308/ADG1309

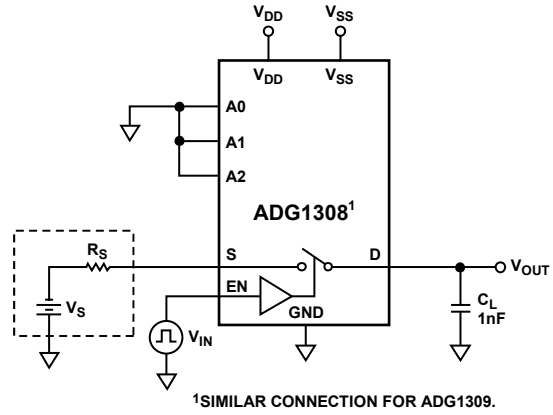
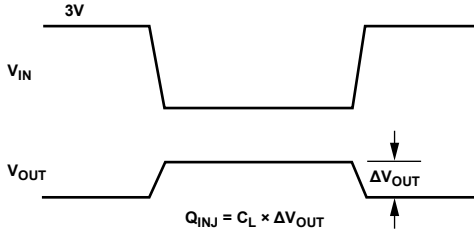

Figure 19. Charge Injection

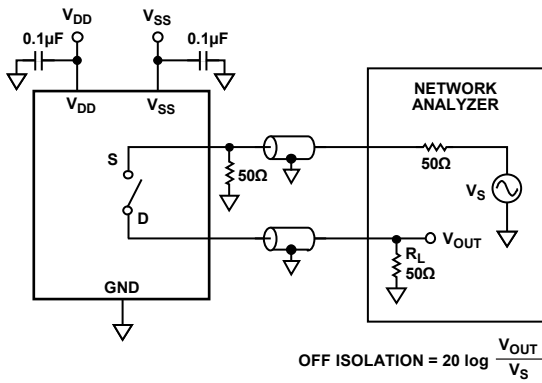

Figure 20. Off Isolation

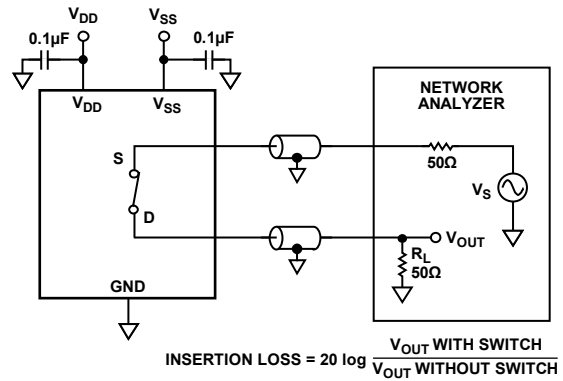

Figure 22. Bandwidth

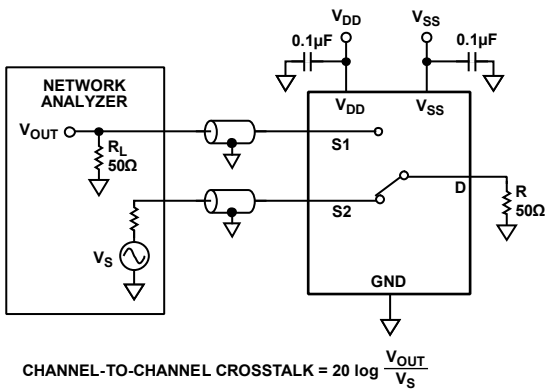

Figure 21. Channel-to-Channel Crosstalk

TERMINOLOGY

R_{ON}

Ohmic resistance between D and S.

ΔR_{ON}

Difference between the R_{ON} of any two channels.

I_S (Off)

Source leakage current when the switch is off.

I_D (Off)

Drain leakage current when the switch is off.

I_D, I_S (On)

Channel leakage current when the switch is on.

V_D (V_S)

Analog voltage on Terminal D and Terminal S.

C_S (Off)

Channel input capacitance for off condition.

C_D (Off)

Channel output capacitance for off condition.

C_D, C_S (On)

On switch capacitance.

C_{IN}

Digital input capacitance.

t_{ON} (EN)

Delay time between the 50% and 90% points of the digital input and switch on condition.

t_{OFF} (EN)

Delay time between the 50% and 90% points of the digital input and switch off condition.

$t_{TRANSITION}$

Delay time between the 50% and 90% points of the digital inputs and the switch on condition when switching from one address state to another.

T_{BBM}

Off time measured between the 80% point of both switches when switching from one address state to another.

V_{INL}

Maximum input voltage for Logic 0.

V_{INH}

Minimum input voltage for Logic 1.

I_{INL} (I_{INH})

Input current of the digital input.

I_{DD}

Positive supply current.

I_{SS}

Negative supply current.

Off Isolation

A measure of unwanted signal coupling through an off channel.

Charge Injection

A measure of the glitch impulse transferred from the digital input to the analog output during switching.

Bandwidth

The frequency at which the output is attenuated by 3 dB.

On Response

The frequency response of the on switch.

OUTLINE DIMENSIONS

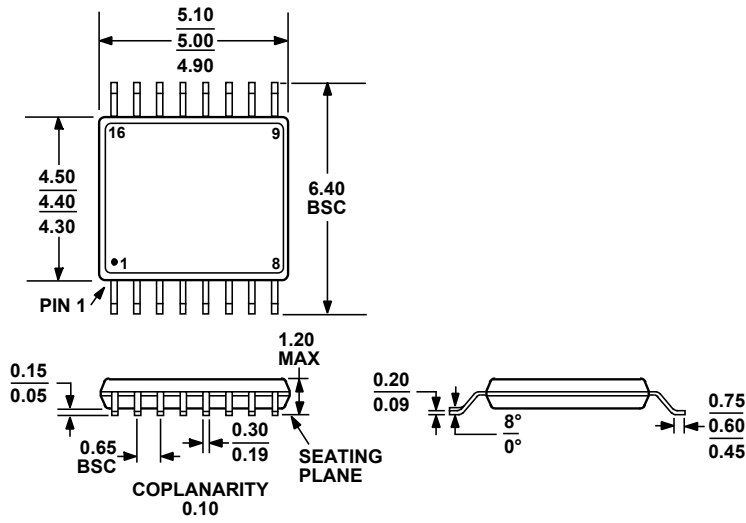

COMPLIANT TO JEDEC STANDARDS MO-153-AB

Figure 23. 16-Lead Thin Shrink Small Outline Package [TSSOP] (RU-16)

Dimensions shown in millimeters

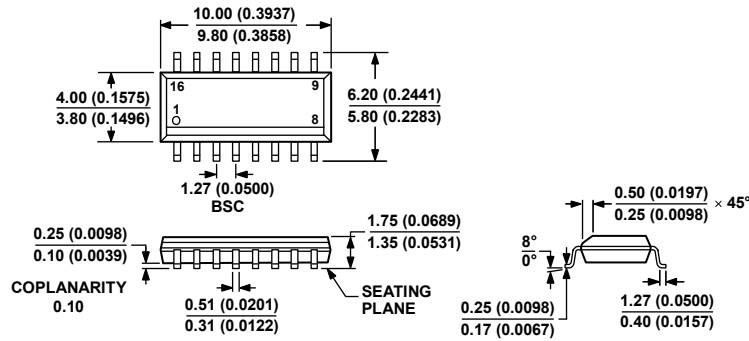

COMPLIANT TO JEDEC STANDARDS MS-012-AC

CONTROLLING DIMENSIONS ARE IN MILLIMETERS; INCH DIMENSIONS (IN PARENTHESES) ARE ROUNDED-OFF MILLIMETER EQUIVALENTS FOR REFERENCE ONLY AND ARE NOT APPROPRIATE FOR USE IN DESIGN.

Figure 24. 16-Lead Standard Small Outline Package [SOIC_N]

Narrow Body

(R-16)

Dimensions shown in millimeters and (inches)

060606-A

ORDERING GUIDE

Model	Temperature Range	Package Description	Package Option
ADG1308BRUZ ¹	-40°C to +105°C	16-Lead Thin Shrink Small Outline Package [TSSOP]	RU-16
ADG1308BRUZ-REEL7 ¹	-40°C to +105°C	16-Lead Thin Shrink Small Outline Package [TSSOP]	RU-16
ADG1308BRZ ¹	-40°C to +105°C	16-Lead Narrow Body Small Outline Package [SOIC_N]	R-16
ADG1308BRZ-REEL7 ¹	-40°C to +105°C	16-Lead Narrow Body Small Outline Package [SOIC_N]	R-16
ADG1309BRUZ ¹	-40°C to +105°C	16-Lead Thin Shrink Small Outline Package [TSSOP]	RU-16
ADG1309BRUZ-REEL7 ¹	-40°C to +105°C	16-Lead Thin Shrink Small Outline Package [TSSOP]	RU-16
ADG1309BRZ ¹	-40°C to +105°C	16-Lead Narrow Body Small Outline Package [SOIC_N]	R-16
ADG1309BRZ-REEL7 ¹	-40°C to +105°C	16-Lead Narrow Body Small Outline Package [SOIC_N]	R-16

¹ Z = RoHS Compliant Part.

NOTES

NOTES

Looking for pricing, stock, or lifecycle information?

Click below to explore more details on WIN SOURCE:

 [View ADG1309BRUZ-REEL7 on WIN SOURCE](#)

 [Analog Devices Inc. Information](#)

Optimize Your Supply Chain with WIN SOURCE Solutions

-  Global Sourcing Solution
-  Obsolete Management
-  Cost Control Management
-  Shortage Management
-  Alternative Solution
-  Excess Inventory Management