



THE DATASHEET OF NB3U23CMNTAG



1.2 V Dual Channel CMOS Buffer/Translator

NB3U23C

Description

The NB3U23C is a 2-input, 2-output buffer/voltage translator for UFS (Universal Flash Storage) in portable consumer applications such as mobile phones, tablets, cameras, etc. This dual channel CMOS buffer accepts 1.8 V CMOS input and translates it to 1.2 V CMOS output. The device is powered using single supply of 1.2 V $\pm 5\%$.

The NB3U23C is packaged in 2 ultra-small 6-pin packages: the 6 pin SC70 and a 6 pin thin UDFN package.

Features

- Operating Frequency: 52 MHz (Max)
- Propagation Delay: 5 ns (Max)
- Low Standby Current: < 10 μ A at 1.2 V V_{DD}
- Low Phase Noise Floor: -150 dBc/Hz (Typ)
- Rise/Fall Times ($t_{r/f}$): 2 ns (Max)
- ESD Protection Exceeds JEDEC Standards
 - ◆ 2000 V Human-Body Model (JS-001-2012)
 - ◆ 200 V Machine Model (JESD22-A115C)
 - ◆ 1000 V Charged-Device Model (JESDC101E)
- Operating Supply Voltage Range (V_{DD}): 1.2 V $\pm 5\%$
- Operating Temperature Range (Industrial): -40°C to 85°C
- These are Pb-Free Devices

MARKING DIAGRAMS



SC-70
SQ SUFFIX
CASE 419B

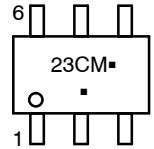

23C = Device Code
M = Date Code*
■ = Pb-Free Package
(Note: Microdot may be in either location)

*Date Code orientation and/or position may vary depending upon manufacturing location.



UDFN6
MN SUFFIX
CASE 517CW



C = Device Code
M = Date Code

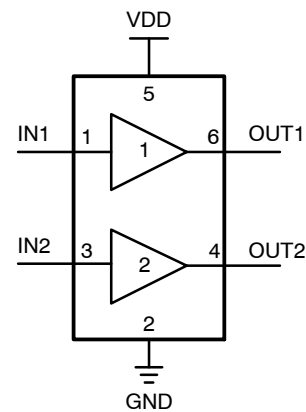

Figure 1. Simplified Logic Diagram

ORDERING INFORMATION

See detailed ordering and shipping information on page 4 of this data sheet.

NOTE: Some of the devices on this data sheet have been **DISCONTINUED**. Please refer to the table on page 4.

NB3U23C

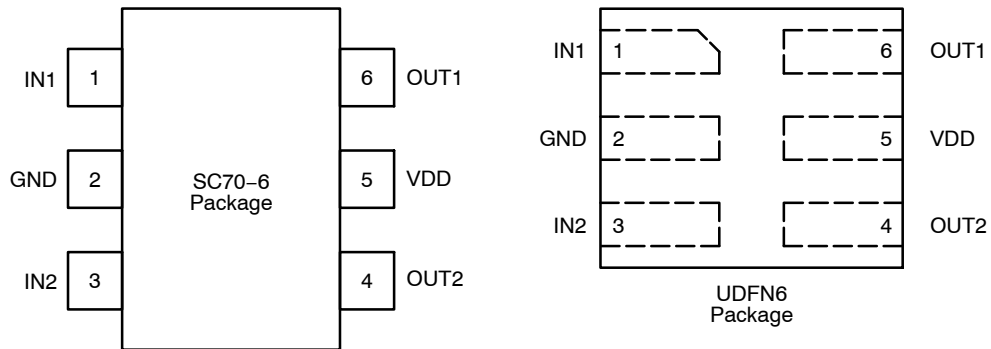

Figure 2. Pinout Diagram (Top Views)

Table 1. PIN DESCRIPTION

Number	Name	Description
1	IN1	Input Clock Signal – Channel 1
2	GND	Power Supply Ground (0 V)
3	IN2	Input Clock Signal – Channel 2
4	OUT2	Output – Channel 2
5	VDD	Power Supply Voltage
6	OUT1	Output – Channel 1

Table 2. ATTRIBUTES

Characteristic	Value
ESD Protection Human Body Model Machine Model Charge Device Model	2 kV min 200 V min 1 kV min
Moisture Sensitivity (Note 1)	Level 1
Flammability Rating Oxygen Index: 28 to 34	UL 94 V-0 @ 0.125 in
Transistor Count	120
Meets or exceeds JEDEC Spec EIA/JESD78 IC Latchup Test II	

1. For additional information, see Application Note [AND8003/D](#).

NB3U23C

Table 3. MAXIMUM RATINGS (Note 2)

Symbol	Parameter	Condition 1	Condition 2	Rating	Unit
V _{DD}	Supply Voltage			3.6	V
V _{in}	Input Voltage			-0.5 ≤ V _I ≤ 2.5	V
I _D	Output Current			25	mA
T _A	Operating Temperature Range, Industrial			-40 to +85	°C
T _{stg}	Storage Temperature Range			-65 to +150	°C
θ _{JA}	Thermal Resistance (Junction-to-Ambient)	0 lfpm 500 lfpm (Note 3) 0 lfpm 500 lfpm (Note 3)	SC70-6 UDFN-6	210 126 245 172	°C/W
θ _{JC}	Thermal Resistance (Junction-to-Case)	(Note 3)	SC70-6 UDFN-6	100 150	°C/W
T _{sol}	Wave Solder			260	°C

Stresses exceeding those listed in the Maximum Ratings table may damage the device. If any of these limits are exceeded, device functionality should not be assumed, damage may occur and reliability may be affected.

- Maximum ratings applied to the device are individual stress limit values (not normal operating conditions) and not valid simultaneously. If stress limits are exceeded device functional operation is not implied, damage may occur and reliability may be affected.
- JEDEC standard multilayer board - 2S2P (2 signal, 2 power).

Table 4. ELECTRICAL CHARACTERISTICS (V_{DD} = 1.2 ±5% V, GND = 0 V, T_A = -40°C to +85°C)

Symbol	Characteristic	Conditions	Min	Typ	Max	Unit
DIDD	Power Supply Current (Single Channel Switching @ 52 MHz)	C _L = 20 pF C _L = 5 pF C _L = 1 pF		2.5 1.5 1		mA
	Power Supply Current (Both Channels Switching @ 52 MHz)	C _L = 20 pF C _L = 5 pF C _L = 1 pF		5 3 2		mA
I _{off}	Standby Current	V _i = V _{IH} Max or GND; V _{DD} = 1.2 V, No Output Load			10	µA
V _{IH}	Input High Voltage		0.65 * V _{DD}		1.98	V
V _{IL}	Input Low Voltage		0		0.35 * V _{DD}	V
V _{OH}	Output High Voltage	C _L = 20 pF R _L = 100 kΩ	0.75 * V _{DD}		V _{DD}	V
V _{OL}	Output Low Voltage	C _L = 20 pF R _L = 100 kΩ	0		0.25 * V _{DD}	V
C _{in}	Input Capacitance				5	pF
F _{clk}	Operating Frequency Range		0		52	MHz
t _{pD}	Propagation Delay	INx to OUTx C _L = 20 pF, R _L = 100 kΩ			5	ns
	Phase Noise Floor Density (Notes 4 and 5)	C _L = 20 pF R _L = 100 kΩ		-150		dBc/Hz
	Additive RMS Phase Jitter (Notes 5 and 6)	C _L = 20 pF R _L = 100 kΩ Offset Frequency Range: 50 kHz to 10 MHz		0.15	0.25	ps
DC	Output Duty Cycle (Note 7)	Input Duty Cycle = 50%, Min Input Slew Rate = 1 V/ns	45		55	%
tr/tf	Output Rise/Fall Times	0.2 * V _{DD} to 0.8 * V _{DD} C _L = 20 pF R _L = 100 kΩ			2	ns

Product parametric performance is indicated in the Electrical Characteristics for the listed test conditions, unless otherwise noted. Product performance may not be indicated by the Electrical Characteristics if operated under different conditions.

- White noise floor.
- This parameter refers to the random jitter only.
- The output RMS phase jitter can be calculated using the following equation:
(Output RMS Phase Jitter)² = (Input RMS Phase Jitter)² + (Additive RMS Phase Jitter)²
- Measured with input voltage swing from 0 V to 1.8 V.

NB3U23C

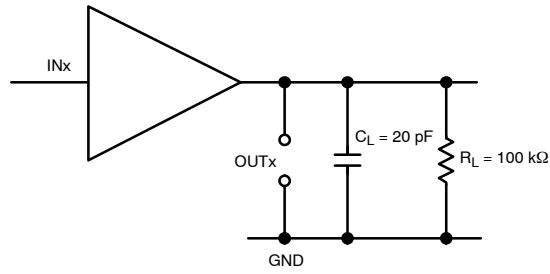

Figure 3. Typical Test Setup for Evaluation

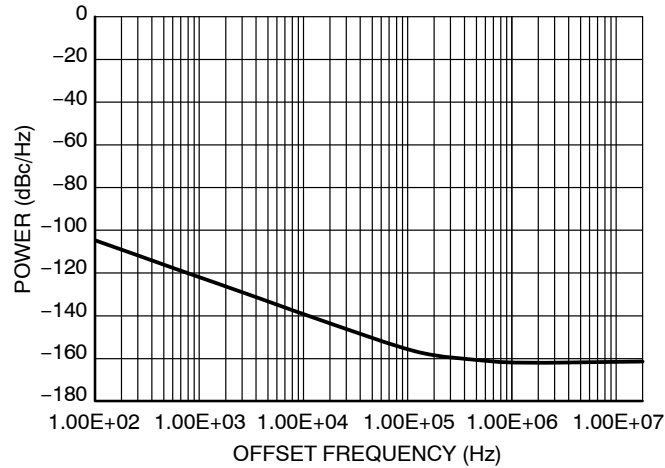

Figure 4. Typical Phase Noise Plot at 50 MHz Carrier Frequency

ORDERING INFORMATION

Device	Package	Shipping [†]
NB3U23CMNTAG	UDFN6 (Pb-Free)	3,000 / Tape & Reel

DISCONTINUED (Note 8)

NB3U23CSQTCG	SC-70-6 (Pb-Free)	3,000 / Tape & Reel
--------------	----------------------	---------------------

[†]For information on tape and reel specifications, including part orientation and tape sizes, please refer to our Tape and Reel Packaging Specifications Brochure, BRD8011/D.

8. **DISCONTINUED:** This device is not recommended for new design. Please contact your **onsemi** representative for information. The most current information on this device may be available on www.onsemi.com.



SCALE 4:1

UDFN6 1.2x1.4, 0.4P
CASE 517CW
ISSUE O

DATE 09 JAN 2014

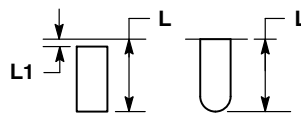
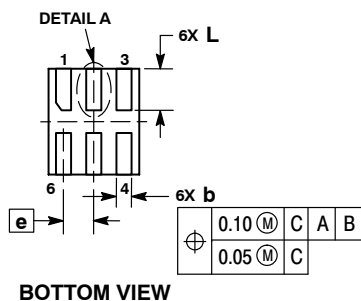
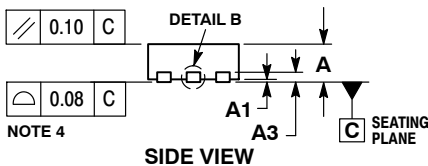
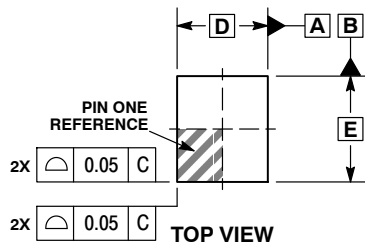

DETAIL A
OPTIONAL TERMINAL
CONSTRUCTIONS

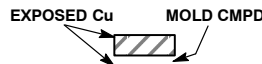

DETAIL B
OPTIONAL
CONSTRUCTION

NOTES:

1. DIMENSIONING AND TOLERANCING PER ASME Y14.5M, 1994.
2. CONTROLLING DIMENSION: MILLIMETERS.
3. DIMENSION b APPLIES TO PLATED TERMINAL AND IS MEASURED BETWEEN 0.15 AND 0.25MM FROM THE TERMINAL TIP.

DIM	MILLIMETERS	
	MIN	MAX
A	0.45	0.55
A1	0.00	0.05
A3	0.13 REF	
b	0.15	0.25
D	1.20 BSC	
E	1.40 BSC	
e	0.40 BSC	
L	0.50	0.60
L1	---	0.15

GENERIC
MARKING DIAGRAM*



- X = Specific Device Code
- M = Month Code

*This information is generic. Please refer to device data sheet for actual part marking. Pb-Free indicator, "G" or microdot "•", may or may not be present.

RECOMMENDED
SOLDERING FOOTPRINT*

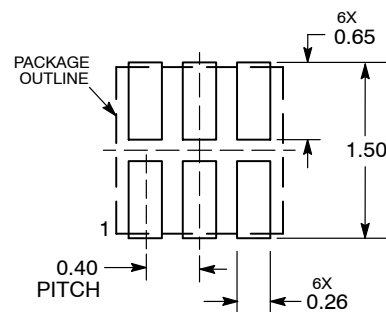

DIMENSIONS: MILLIMETERS

*For additional information on our Pb-Free strategy and soldering details, please download the onsemi Soldering and Mounting Techniques Reference Manual, SOLDERRM/D.

DOCUMENT NUMBER:	98AON81510F	Electronic versions are uncontrolled except when accessed directly from the Document Repository. Printed versions are uncontrolled except when stamped "CONTROLLED COPY" in red.
DESCRIPTION:	UDFN6 1.2X1.4, 0.4P	PAGE 1 OF 1

onsemi and ONSEMI are trademarks of Semiconductor Components Industries, LLC dba onsemi or its subsidiaries in the United States and/or other countries. onsemi reserves the right to make changes without further notice to any products herein. onsemi makes no warranty, representation or guarantee regarding the suitability of its products for any particular purpose, nor does onsemi assume any liability arising out of the application or use of any product or circuit, and specifically disclaims any and all liability, including without limitation special, consequential or incidental damages. onsemi does not convey any license under its patent rights nor the rights of others.

onsemi, **Onsemi**, and other names, marks, and brands are registered and/or common law trademarks of Semiconductor Components Industries, LLC dba "**onsemi**" or its affiliates and/or subsidiaries in the United States and/or other countries. **onsemi** owns the rights to a number of patents, trademarks, copyrights, trade secrets, and other intellectual property. A listing of **onsemi**'s product/patent coverage may be accessed at www.onsemi.com/site/pdf/Patent-Marking.pdf. **onsemi** reserves the right to make changes at any time to any products or information herein, without notice. The information herein is provided "as-is" and **onsemi** makes no warranty, representation or guarantee regarding the accuracy of the information, product features, availability, functionality, or suitability of its products for any particular purpose, nor does **onsemi** assume any liability arising out of the application or use of any product or circuit, and specifically disclaims any and all liability, including without limitation special, consequential or incidental damages. Buyer is responsible for its products and applications using **onsemi** products, including compliance with all laws, regulations and safety requirements or standards, regardless of any support or applications information provided by **onsemi**. "Typical" parameters which may be provided in **onsemi** data sheets and/or specifications can and do vary in different applications and actual performance may vary over time. All operating parameters, including "Typicals" must be validated for each customer application by customer's technical experts. **onsemi** does not convey any license under any of its intellectual property rights nor the rights of others. **onsemi** products are not designed, intended, or authorized for use as a critical component in life support systems or any FDA Class 3 medical devices or medical devices with a same or similar classification in a foreign jurisdiction or any devices intended for implantation in the human body. Should Buyer purchase or use **onsemi** products for any such unintended or unauthorized application, Buyer shall indemnify and hold **onsemi** and its officers, employees, subsidiaries, affiliates, and distributors harmless against all claims, costs, damages, and expenses, and reasonable attorney fees arising out of, directly or indirectly, any claim of personal injury or death associated with such unintended or unauthorized use, even if such claim alleges that **onsemi** was negligent regarding the design or manufacture of the part. **onsemi** is an Equal Opportunity/Affirmative Action Employer. This literature is subject to all applicable copyright laws and is not for resale in any manner.

ADDITIONAL INFORMATION

TECHNICAL PUBLICATIONS:

Technical Library: www.onsemi.com/design/resources/technical-documentation
onsemi Website: www.onsemi.com

ONLINE SUPPORT: www.onsemi.com/support

For additional information, please contact your local Sales Representative at www.onsemi.com/support/sales

Looking for pricing, stock, or lifecycle information?

Click below to explore more details on WIN SOURCE:

- ⊖ [View NB3U23CMNTAG](#) on WIN SOURCE
- ⊖ [ON Semiconductor](#) Information

Optimize Your Supply Chain with WIN SOURCE Solutions

- ✓ Global Sourcing Solution
- ✓ Obsolete Management
- ✓ Cost Control Management
- ✓ Shortage Management
- ✓ Alternative Solution
- ✓ Excess Inventory Management