



**THE DATASHEET OF
FXP831.07.0100C**





TAOGLAS®



Datasheet

Freedom

Part No:
FXP831.07.0100C

Description

FXP.831 Freedom 2.4/5.8/7.125GHz Ground Coupled Antenna

Features:

Flexible Polymer Antenna
Covers: Wi-Fi® 2.4/5.8/7.125GHz
Cable: 100mm 1.37 Coaxial
Connector: I-PEX MHF® I (U.FL comp)
Dims: 45 x 7.0 x 0.1mm
RoHS & Reach Compliant

1.	Introduction	3
2.	Specification	4
3.	Mechanical Drawing	5
4.	Packaging	6
5.	Antenna Characteristics	8
6.	Radiation Patterns	12
<hr/>		
	Changelog	19

Taoglas makes no warranties based on the accuracy or completeness of the contents of this document and reserves the right to make changes to specifications and product descriptions at any time without notice. Taoglas reserves all rights to this document and the information contained herein. Reproduction, use or disclosure to third parties without express permission is strictly prohibited.

Ireland & USA
ISO 9001:2015
Certified



Taiwan
ISO 9001:2015
Certified



1. Introduction



The FXP831 is a high efficiency, small, dual-band, dipole antenna for 2.4/4.9-6GHz band including DSRC, V2V, Wi-Fi®, Bluetooth®, Zigbee® and other applications in these bands. The FXP.831 has a peak gain of 2.7dBi at 2.4GHz and efficiencies of 49%, and 5.5-7.2dBi and 54-61% along bands 5.8GHz to 7.125GHz.

This Taoglas patent granted antenna is unique in the market because it is made from poly-flexible material, has a tiny form factor (45 x 7 x .01mm) and has double-sided 3M tape for easy “peel and stick” mounting. The cable routes conveniently directly out of the bottom of the antenna, reducing the volume the antenna takes up in the device to an absolute minimum compared to other designs. The FXP.831 is the ideal all-round antenna solution for squeezing into narrow spaces and still maintaining high performance, for example on the inside top or adjacent side applied directly to the plastic housing of LCD devices.

Many module manufacturers specify peak gain limits for any antennas that are to be connected to that module. Those peak gain limits are based on free-space conditions. In practice, the peak gain of an antenna tested in free-space can degrade by at least 1 or 2dBi when put inside a device. So ideally you should go for a slightly higher peak gain antenna than mentioned on the module specification to compensate for this effect, giving you better performance. Upon testing of any of our antennas with your device and a selection of appropriate layout, integration technique, or cable, Taoglas can make sure any of our antennas’ peak gain will be below the peak gain limits. Taoglas can then issue a specification and/or report for the selected antenna in your device that will clearly show it complying with the peak gain limits, so you can be assured you are meeting regulatory requirements for that module.

For example, a module manufacturer may state that the antenna must have less than 2dBi peak gain, but you don’t need to select an embedded antenna that has a peak gain of less than 2dBi in free space. This will give you a less optimized solution. It is better to go for a slightly higher free-space peak gain of 3dBi or more if available. Once that antenna gets integrated into your device, performance will degrade below this 2dBi peak gain due to the effects of GND plane, surrounding components, and device housing. If you want to be absolutely sure, contact Taoglas and we will test. Choosing a Taoglas antenna with a higher peak gain than what is specified by the module manufacturer and enlisting our help will ensure you are getting the best performance possible without exceeding the peak gain limits.

The cable and connector are fully customizable, for further information contact your regional Taoglas customer support team.

2. Specification

Wi-Fi Electrical									
Band	Frequency (MHz)	Measurement	Efficiency (%)	Average Gain (dB)	Peak Gain (dBi)	Impedance	Polarization	Radiation Pattern	Max. input power
Wi-Fi - 2GHz	2400-2500	2mm ABS	49.5	-3.05	2.74	50 Ω	Linear	Omni directional	10W
		Free Space	57.0	-2.44	3.28				
Wi-Fi - 5GHz	5150-5850	2mm ABS	61.0	-2.15	7.24				
		Free Space	49.1	-3.09	5.49				
Wi-Fi - 6GHz	5925-7125	2mm ABS	50.9	-2.93	5.55				
		Free Space	54.0	-2.68	7.76				

Mechanical	
Dimensions	45mm x 7mm
Antenna Body Material	Polymer
Cable	Gray 100mm 1.37 co-axial
Connector	IPEX MHFHT

Environmental	
Operation Temperature	-40°C to 85°C
Storage Temperature	-40°C to 85°C
Relative Humidity	Non-condensing 65°C 95% RH

3. Mechanical Drawing

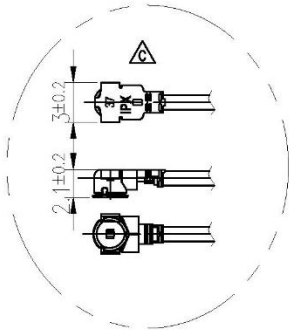

Detail A
Scale: 1:1

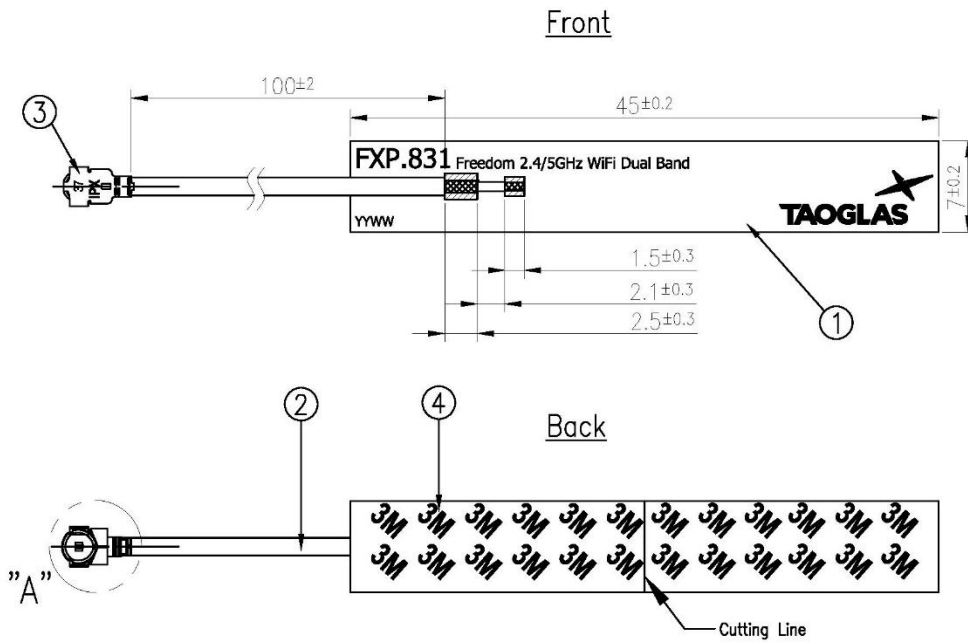

	Name	P/N	Material	Finish	QTY
1	FXP831 FPCB	100111B021111A	Polymer 0.24t	Black	1
2	1.37 Coaxial Cable	300415C000000A	FEP	Gray	1
3	IPEX MHFHT	204511G000000A	Brass	Au Plated	1
4	Double Side Adhesive	100111B021111A	3M 467	Brown Liner	1

4. Precautions for usage

Mating / unmating

(1) To disconnect connectors, insert the end portion of I-PEX under the connector flanges and pull off vertically, in the direction of the connector mating axis.

(2) To mate the connectors, the mating axes of both connectors must be aligned and the connectors can be mated. The "click" will confirm fully mated connection.

Do not attempt to insert on an extreme angle.

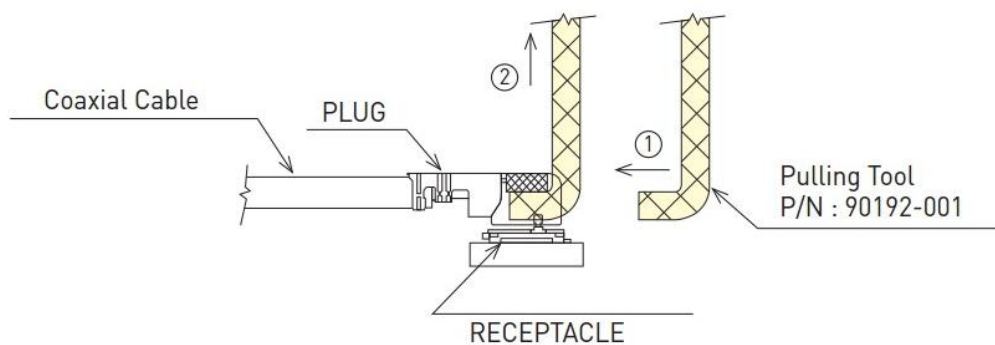

Pull forces on the cable after connectors are mated

After the connectors are mated, do not apply a load to the cable in excess of the values indicated in the diagram below.

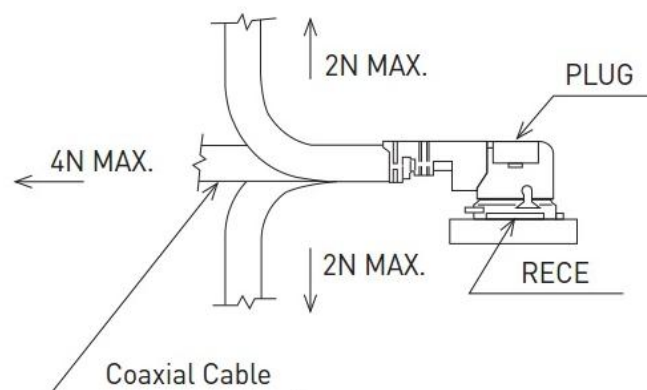

5. Packaging

100pc FXP831.07.0100C per Small PE Bag
 Dimensions: 300 x 100mm
 Weight: 70g

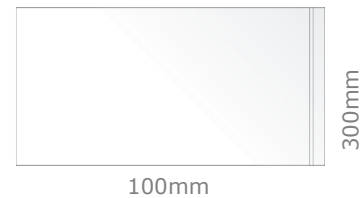
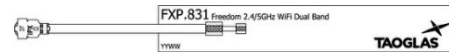

1000pcs FXP831.07.0100C per Large PE Bag
 Dimensions: 430 x 280mm
 Weight: 807g



5000pcs FXP831.07.0100C per Carton
 Carton Dimensions: 320 x 250 x 230 mm
 Weight: 4.5Kg

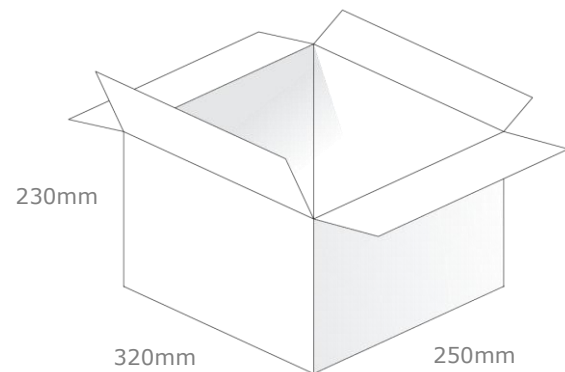

Pallet Dimensions:
 1200 x 1000 x 1350mm
 60 Cartons per Pallet
 12 Cartons per layer, 5 Layers

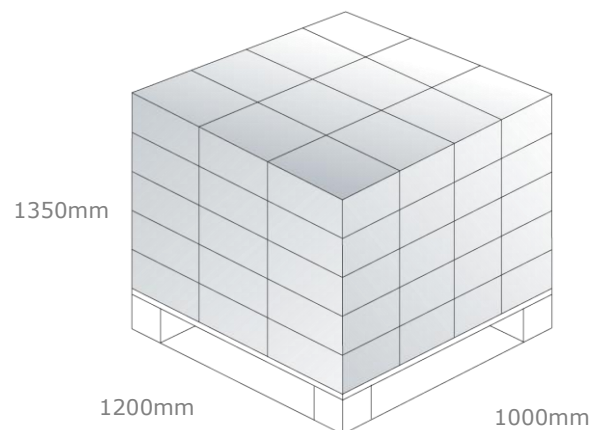

6. Antenna Characteristics

6.1 Test Setup

AUT



Vector Network Analyzer

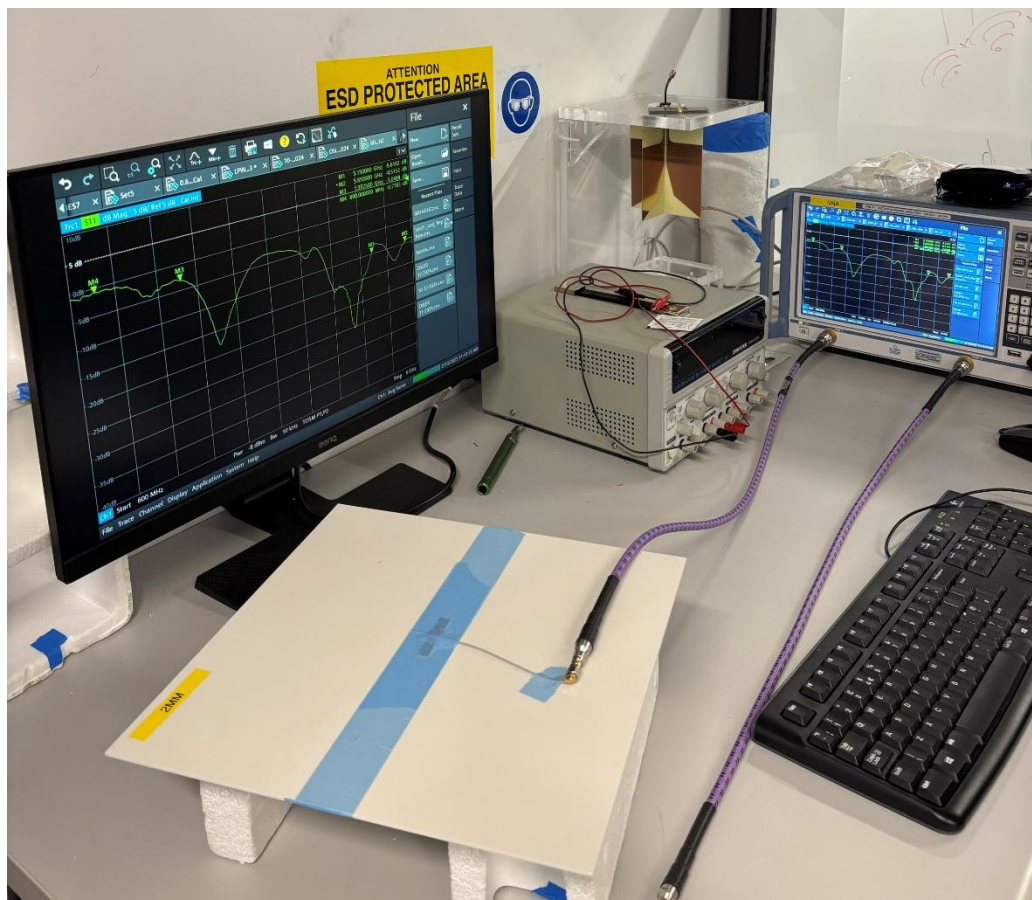

VNA Test Set-up on 2mm ABS

6.2 Return Loss

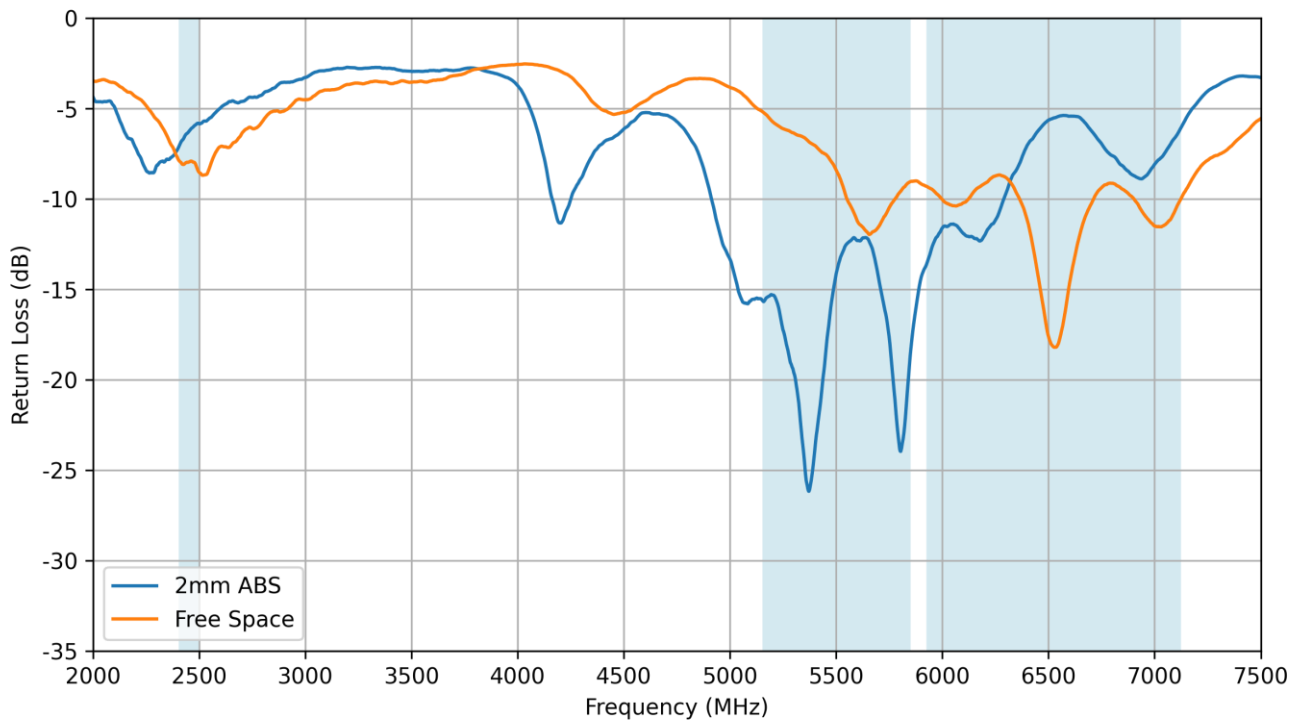

6.3 VSWR

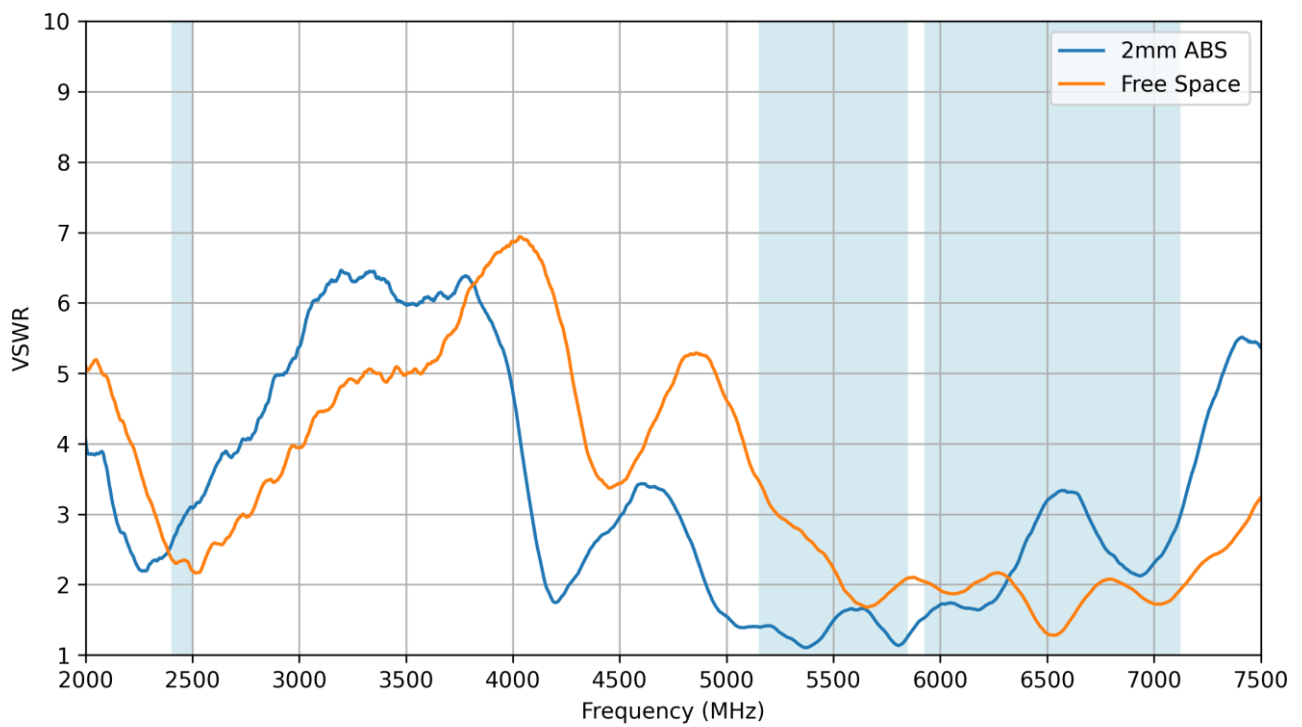

6.4 Efficiency

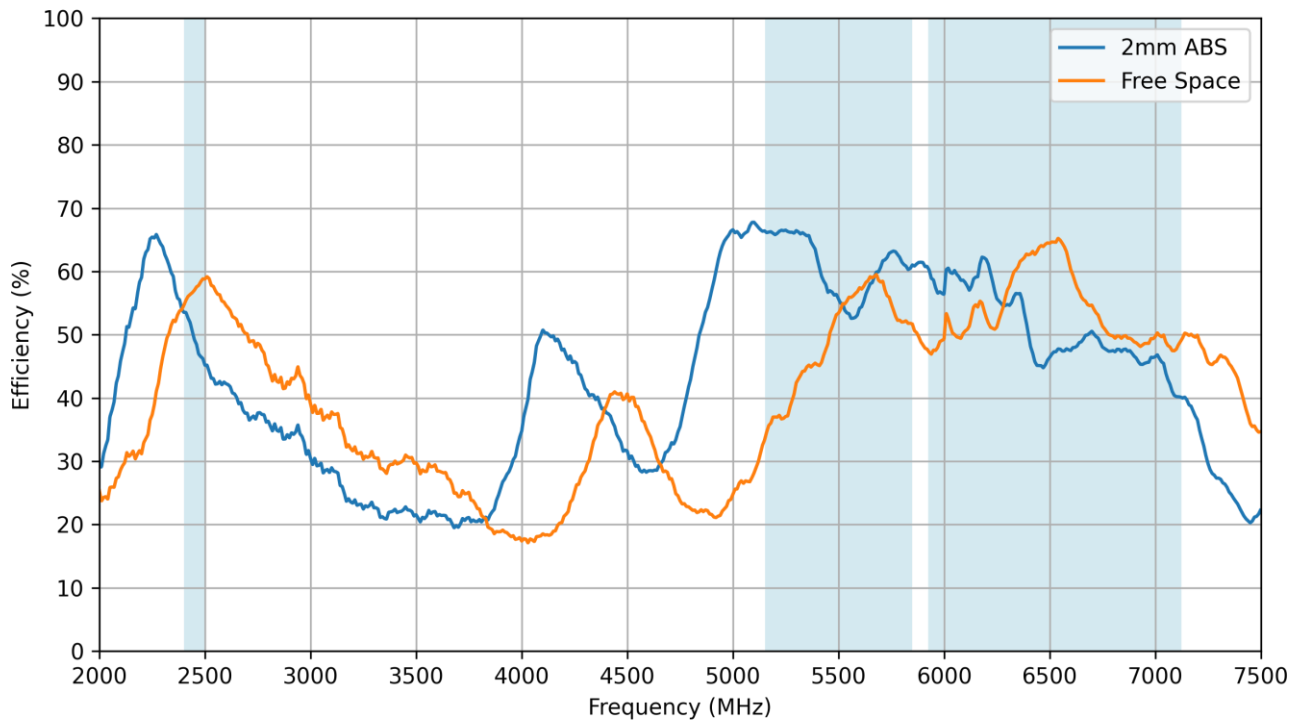

6.5 Average Gain

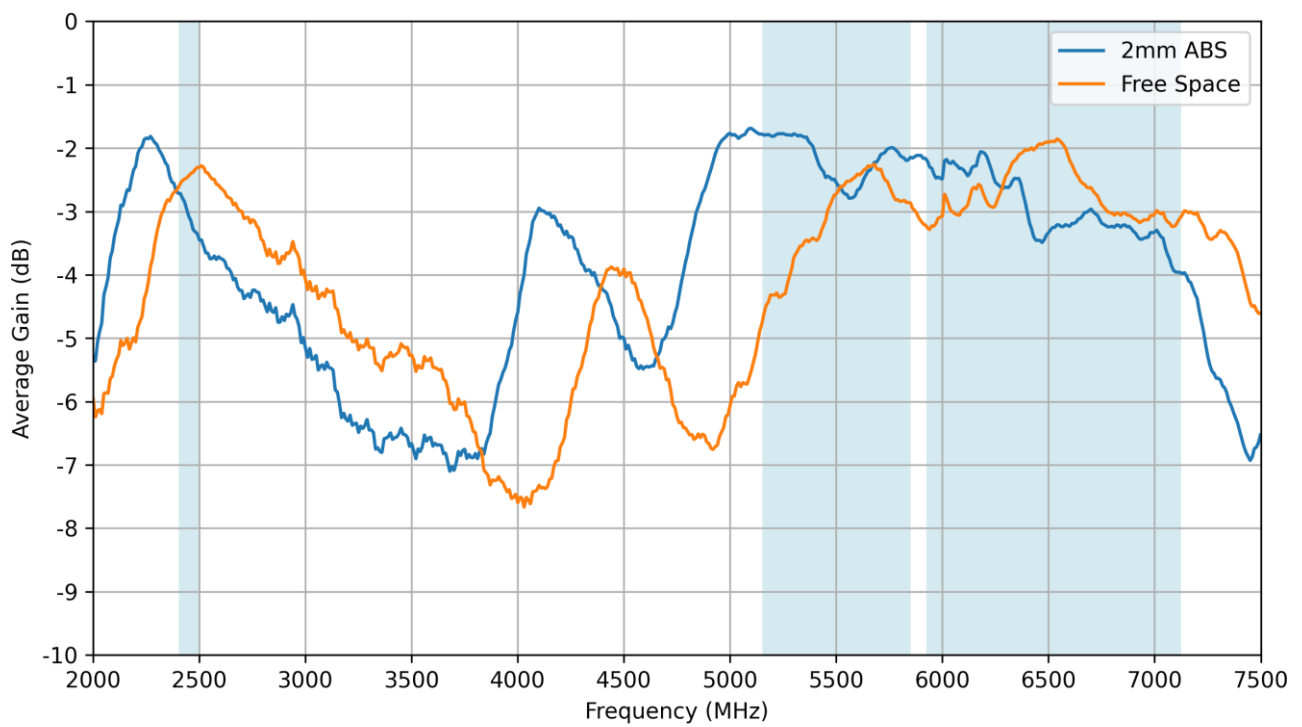

6.6 Peak Gain

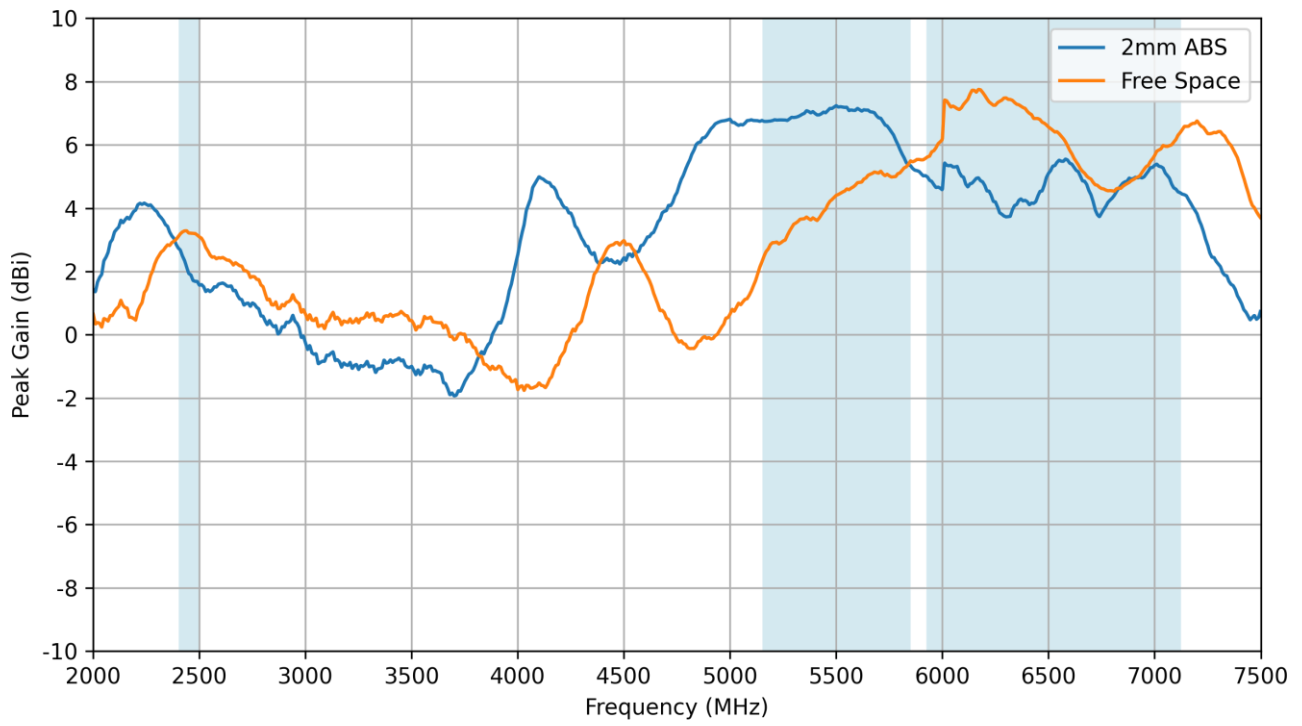

7. Radiation Patterns

7.1 Test Setup

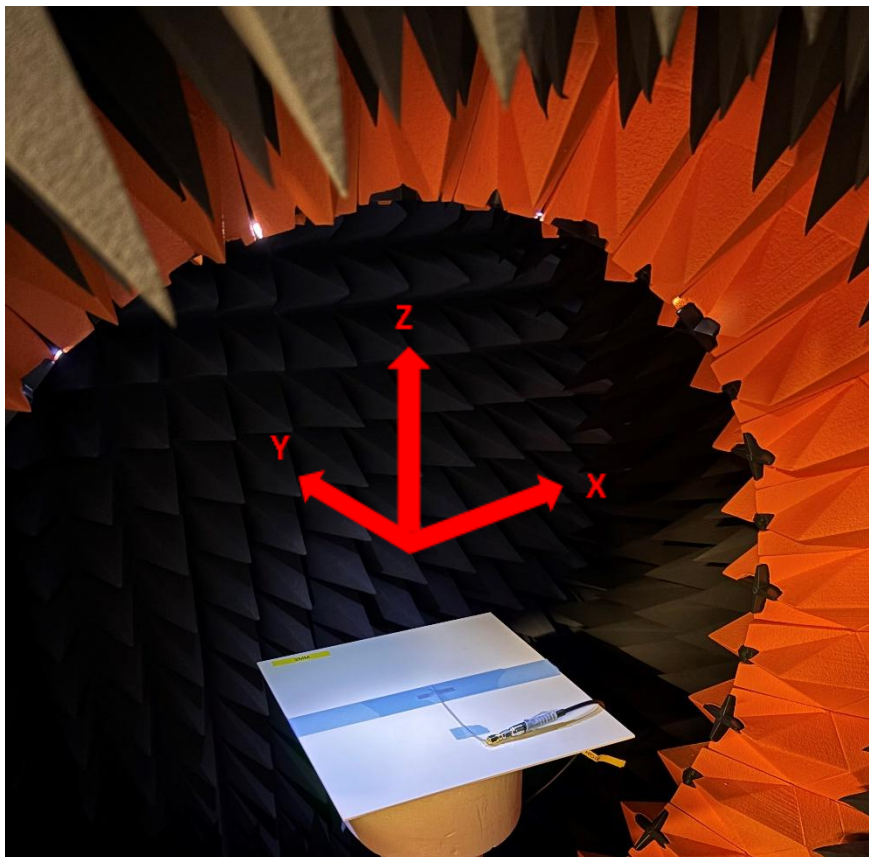
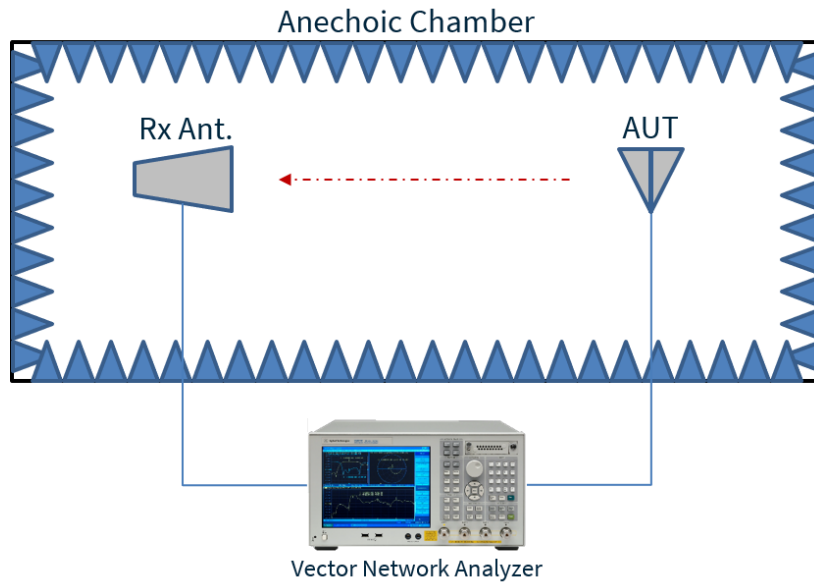

Chamber Test Set-up on 2mm ABS

7.2 2mm ABS Patterns at 2450 MHz

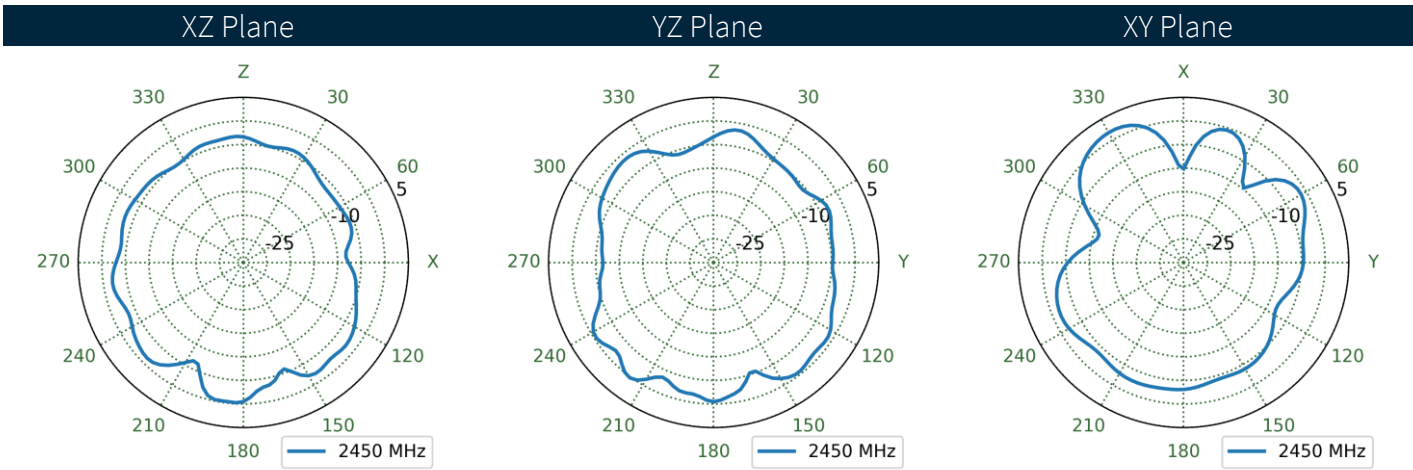
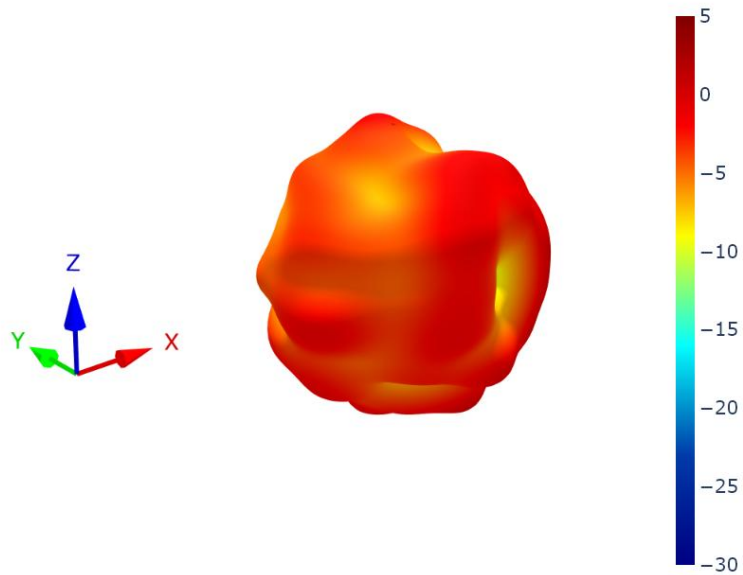

7.3 Free Space Patterns at 2450 MHz

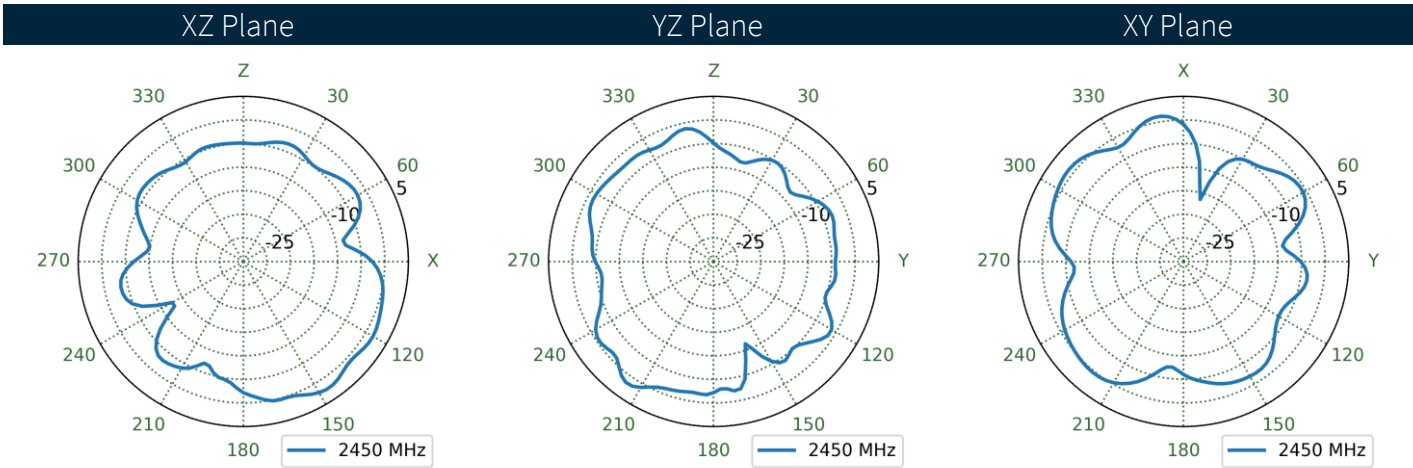
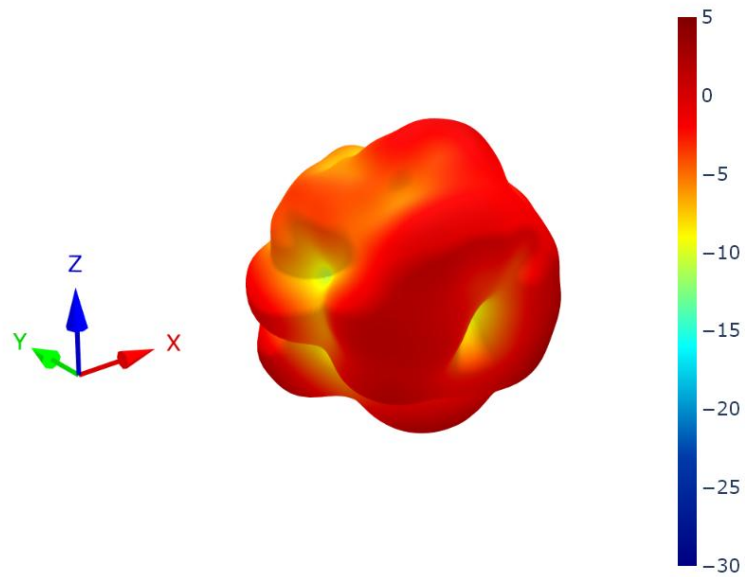

7.4 2mm ABS Patterns at 5500 MHz

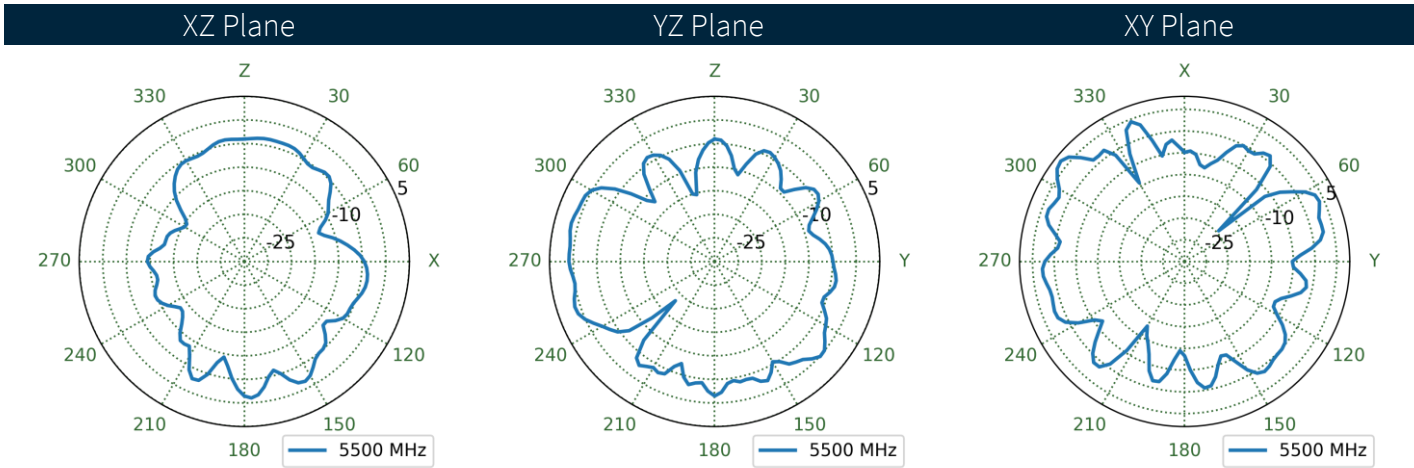
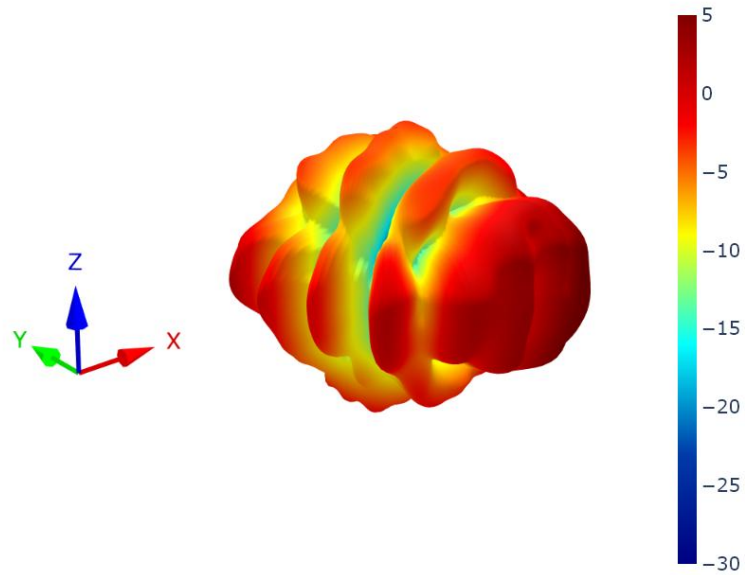

7.5 Free Space Patterns at 5500 MHz

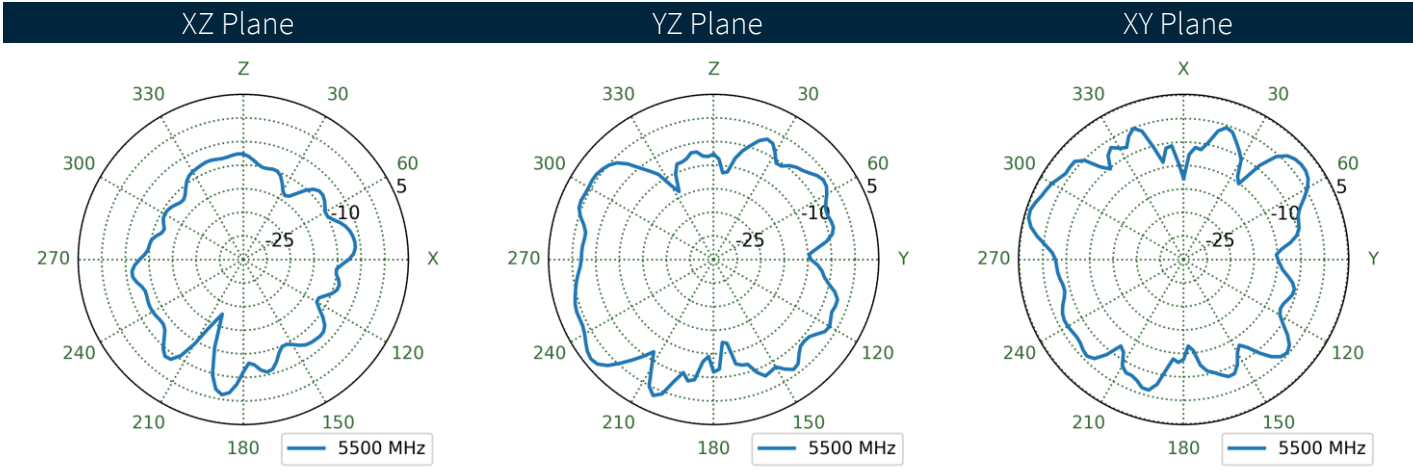
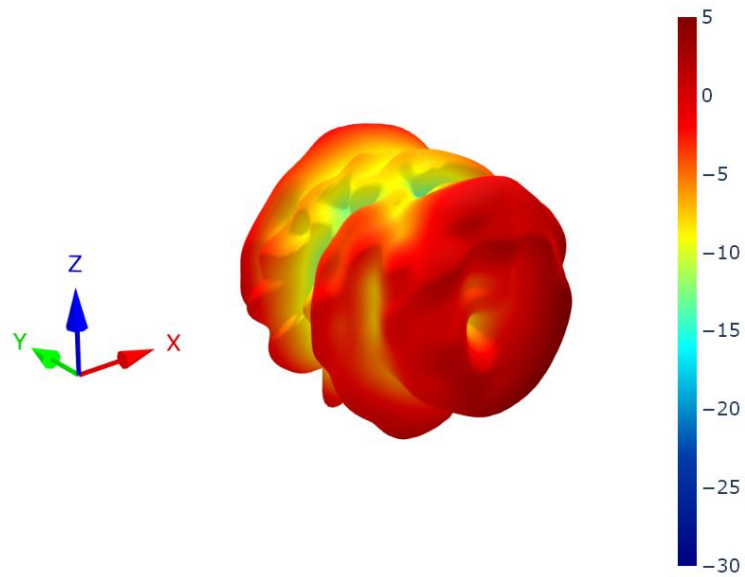

7.6 2mm ABS Patterns at 6520 MHz

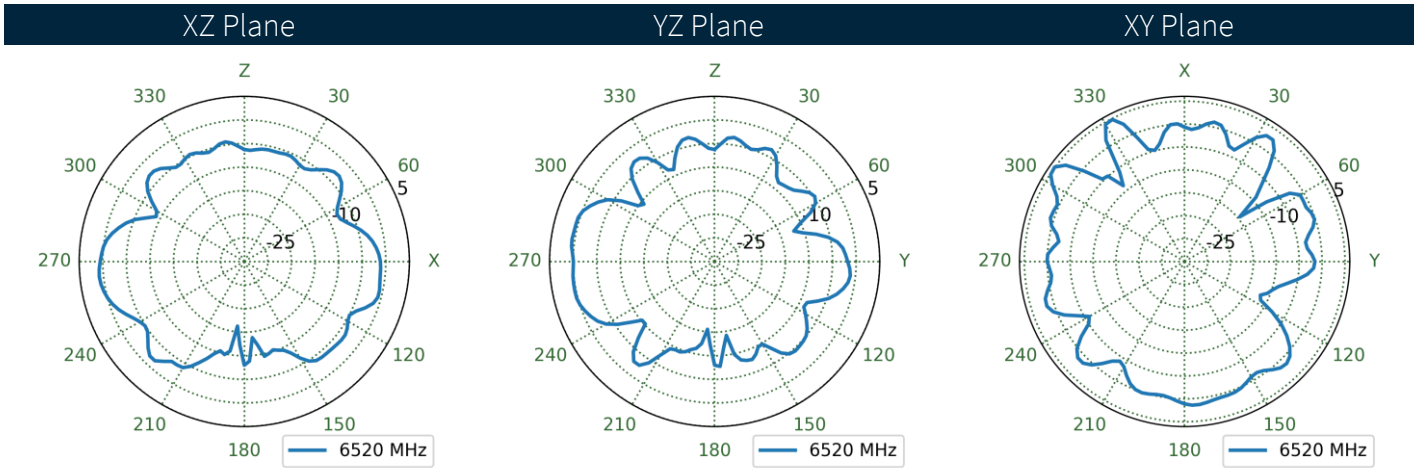
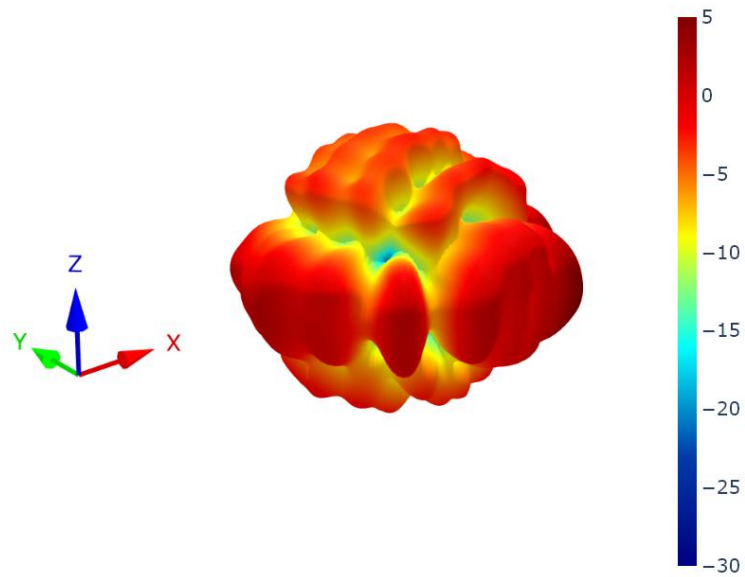

7.7 Free Space Patterns at 6520 MHz

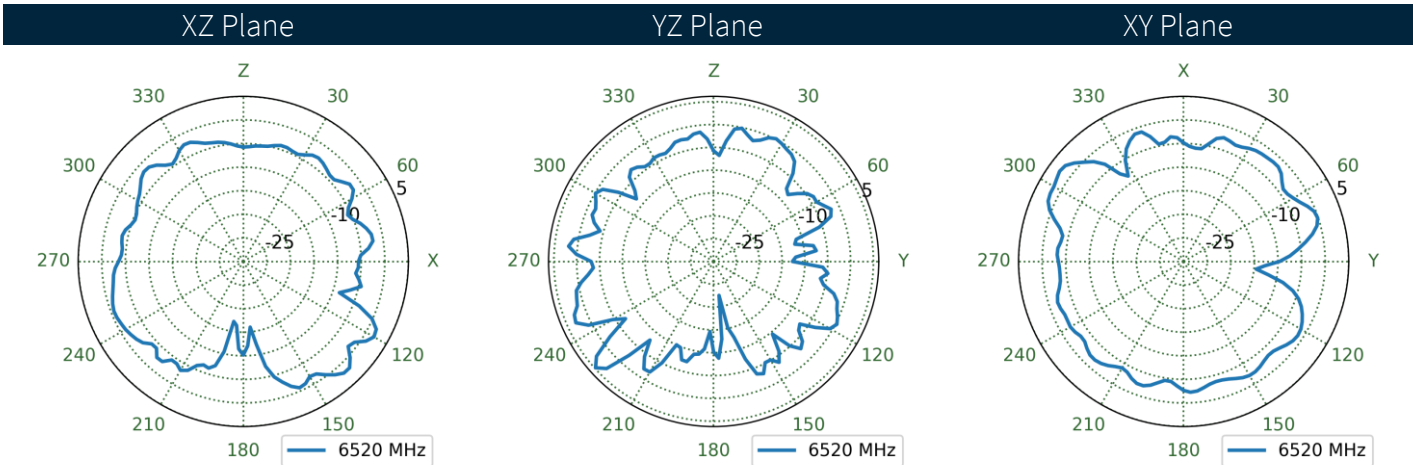
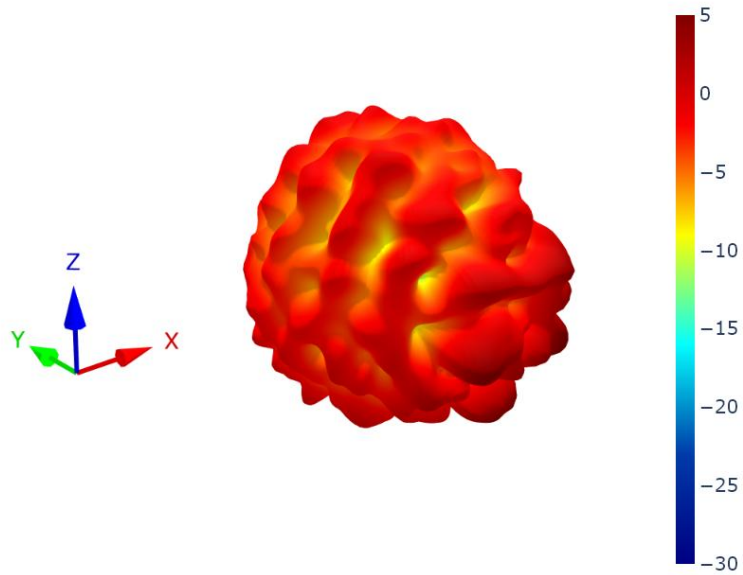

Changelog for the datasheet

SPE-11-8-026 – FXP831.07.0100C

Revision: K (Current Version)

Date:	2025-02-18
Changes:	Full datasheet update including Wi-Fi, Bluetooth, ZigBee Trademarking.
Changes Made by:	Gary West

Previous Revisions

Revision: J

Date:	2019-03-01
Changes:	Updated specifications
Changes Made by:	Cesar Sousa

Revision: E

Date:	2015-02-15
Changes:	Added note on Intro
Changes Made by:	Aine Doyle

Revision: I

Date:	2019-05-14
Changes:	Images Updated
Changes Made by:	David Connolly

Revision: D

Date:	2014-10-04
Changes:	Added in Batch code
Changes Made by:	Aine Doyle

Revision: H

Date:	2016-06-22
Changes:	Added patent
Changes Made by:	Aine Doyle

Revision: C

Date:	2012-01-14
Changes:	Updated intro
Changes Made by:	Aine Doyle

Revision: G

Date:	2015-07-09
Changes:	Specification Updated
Changes Made by:	Aine Doyle

Revision: B

Date:	2011-07-14
Changes:	
Changes Made by:	Aine Doyle

Revision: F

Date:	2015-06-30
Changes:	Added in DSRC
Changes Made by:	Aine Doyle

Revision: A (Original First Release)

Date:	2011-07-01
Notes:	
Author:	Aine Doyle



www.taoglas.com



Looking for pricing, stock, or lifecycle information?

Click below to explore more details on WIN SOURCE:

 [View FXP831.07.0100C on WIN SOURCE](#)

 [Taoglas Limited](#) Information

Optimize Your Supply Chain with WIN SOURCE Solutions

-  Global Sourcing Solution
-  Obsolete Management
-  Cost Control Management
-  Shortage Management
-  Alternative Solution
-  Excess Inventory Management