



THE DATASHEET OF ADUCM322BBCZI-RL



FEATURES

Analog input/output

- Multichannel, 12-bit, 1 MSPS analog-to-digital converter (ADC)
 - Up to 16 ADC input channels
 - 0 V to VREF analog input range
 - Single-ended mode
 - AVDD and IOVDD monitors
- 12-bit voltage output digital-to-analog converters (VDACs)
 - 8 VDACs with a range of 0 V to 2.5 V or AVDD outputs

Voltage comparator

Microcontroller

- ARM Cortex-M3 processor, 32-bit RISC architecture
- Serial wire port supports code download and debug

Clocking options

- 80 MHz phase-locked loop (PLL) with programmable divider
- Trimmed on-chip oscillator ($\pm 3\%$)
- External 16 MHz crystal option
- External clock source up to 80 MHz

Memory

- 2 × 128 kB independent Flash/EE memories
- 10,000 cycle Flash/EE endurance
- 20-year Flash/EE retention
- 32 kB SRAM

Software triggered in-circuit reprogrammability via I²C

On-chip peripherals

- MDIO slave up to 4 MHz
- 2 × I²C, 2 × SPI, UART
- Multiple general-purpose input/output (GPIO) balls: 3.6 V compliant
- 7 × 1.2 V compatible when used for MDIO
- 32-element programmable logic array (PLA)
- 3 general-purpose timers
- Wake-up timer
- Watchdog timer
- 16-bit pulse width modulator (PWM)

Power

- Supply range: 2.9 V to 3.6 V
- Flexible operating modes for low power applications

Packages and temperature range

- 6 mm × 6 mm, 96-ball CSP_BGA package
- Fully specified for -40°C to $+105^{\circ}\text{C}$ ambient operation

Tools

- QuickStart development system
- Full third-party support

APPLICATIONS

Optical networking

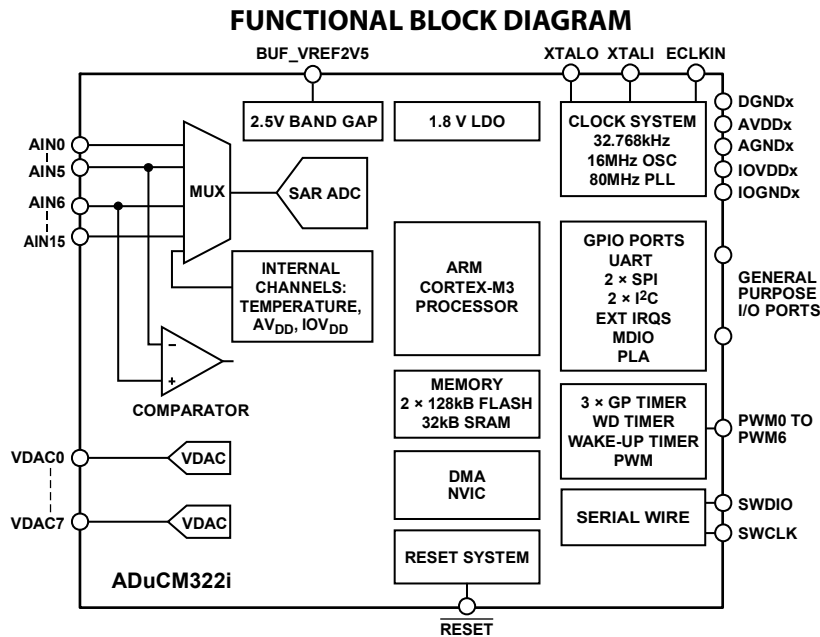

Figure 1.

Rev. 0

Document Feedback

Information furnished by Analog Devices is believed to be accurate and reliable. However, no responsibility is assumed by Analog Devices for its use, nor for any infringements of patents or other rights of third parties that may result from its use. Specifications subject to change without notice. No license is granted by implication or otherwise under any patent or patent rights of Analog Devices. Trademarks and registered trademarks are the property of their respective owners.

TABLE OF CONTENTS

Features	1	Pin Configuration and Function Descriptions.....	15
Applications.....	1	Typical Performance Characteristics	20
Functional Block Diagram	1	Applications Information	21
Revision History	2	Recommended Circuit and Component Values	21
General Description	3	Packaging and Ordering Information	23
Specifications.....	4	Outline Dimensions	23
Microcontroller Electrical Specifications	4	Ordering Guide	23
Absolute Maximum Ratings	14		
ESD Caution.....	14		

REVISION HISTORY**2/16—Revision 0: Initial Version**

GENERAL DESCRIPTION

The [ADuCM322i](#) is a fully integrated, single package device that incorporates high performance analog peripherals together with digital peripherals controlled by an 80 MHz ARM® Cortex™-M3 processor and integral flash for code and data.

The ADC on the [ADuCM322i](#) provides 12-bit, 1 MSPS data acquisition on up to 16 input balls. Additionally, chip temperature and supply voltages can be measured.

The ADC input voltage range is 0 V to VREF. A sequencer is provided, which allows a user to select a set of ADC channels to measure in sequence without software involvement during the sequence. The sequence can optionally repeat automatically at a user selectable rate. Up to eight VDACS are provided with output ranges that are programmable to one of two voltage ranges.

The [ADuCM322i](#) can be configured so that the digital and analog outputs retain their output voltages through a watchdog or software reset sequence. Thus, a product can remain functional even while the [ADuCM322i](#) is resetting itself.

The [ADuCM322i](#) has a low power ARM Cortex-M3 processor and a 32-bit RISC machine that offers up to 100 MIPS peak performance. Also integrated on-chip are 2 × 128 kB Flash/EE memory blocks and 32 kB of SRAM. The flash comprises two separate 128 kB blocks supporting execution from one flash block and simultaneous writing/erasing of the other flash block.

The [ADuCM322i](#) operates from an on-chip oscillator or a 16 MHz external crystal and a PLL at 80 MHz. This clock can optionally be divided down to reduce current consumption. Additional low power modes can be set via software. In normal operating mode, the [ADuCM322i](#) digital core consumes about 300 μA per MHz.

The device includes an MDIO interface capable of operating at up to 4 MHz. The capability to simultaneously execute from one flash block and write/erase the other flash block makes the [ADuCM322i](#) ideal for 10G, 40G, and 100G optical applications. The nonerasable kernel code plus flags in user flash provide assistance by allowing user code to robustly switch between the two blocks of user flash code and data spaces.

The [ADuCM322i](#) integrates a range of on-chip peripherals that can be configured under software control, as required in the application. These peripherals include 1 × UART, 2 × I²C, and 2 × SPI serial input/output communication controllers, GPIO, 32-element PLA, three general-purpose timers, plus a wake-up timer and system watchdog timer. A 16-bit PWM with seven output channels is also provided.

GPIO balls on the device power up in high impedance input mode. In output mode, the software chooses between open-drain mode and push-pull mode. The pull-up resistors can be disabled and enabled in software. In GPIO output mode, the inputs can remain enabled to monitor the balls. The GPIO balls can also be programmed to handle digital or analog peripheral signals; in such cases, the ball characteristics are matched to the specific requirement.

A large support ecosystem is available for the ARM Cortex-M3 processor to ease product development of the [ADuCM322i](#). Access is via the ARM serial wire debug port (SW-DP). On-chip factory firmware supports in-circuit serial download via I²C. These features are incorporated into a QuickStart™ development system, supporting this precision analog microcontroller family.

SPECIFICATIONS

MICROCONTROLLER ELECTRICAL SPECIFICATIONS

AVDD = IOVDD = VDD1 = 2.9 V to 3.6 V (see Figure 12), maximum difference between supplies = 0.3 V, VREF = 2.5 V internal reference, $f_{\text{CORE}} = 80$ MHz, $T_A = -40^\circ\text{C}$ to $+105^\circ\text{C}$, unless otherwise noted. The power-up sequence must be VDD1, IOVDDx, and AVDDx, but no delays in the sequence are required.

Table 1.

Parameter	Symbol	Min	Typ	Max	Unit	Test Conditions/Comments
ADC BASIC SPECIFICATIONS						
ADC Power-Up Time			5		μs	Single-ended mode, unless otherwise stated 1 LSB = $2.5 \text{ V}/2^{12}$ Number of data bits 2.5 V internal reference; 1 LSB = $2.5 \text{ V}/2^{12}$ 2.5 V external reference; 1 LSB = $2.5 \text{ V}/2^{12}$ 2.5 V internal reference; 1 LSB = $2.5 \text{ V}/2^{12}$ 2.5 V external reference; 1 LSB = $2.5 \text{ V}/2^{12}$ ADC input 1.25 V; 1 LSB = $2.5 \text{ V}/2^{12}$
Data Rate	f_{SAMPLE}			1	MSPS	
DC Accuracy ¹		12			Bits	
Resolution ¹		16			Bits	
Integral Nonlinearity	INL		± 1.75		LSB	
Differential Nonlinearity	DNL	-0.99	± 0.75	+1.5	LSB	
			± 0.75		LSB	
DC Code Distribution			± 3		LSB	
ADC ENDPOINT ERRORS						
Offset Error			± 200		μV	Using 2.5 V external reference Matching compared to AIN8
Drift ¹		-3.92	0.3	+1.21	$\mu\text{V}/^\circ\text{C}$	
Match			± 1		LSB	
Full-Scale Error			± 400		μV	
Gain Drift ¹		-4		+5	$\mu\text{V}/^\circ\text{C}$	Full-scale error drift minus offset error drift
Match			± 1		LSB	
ADC DYNAMIC PERFORMANCE						
Signal-to-Noise Ratio	SNR		80		dB	$f_{\text{IN}} = 665.25$ Hz sine wave, $f_{\text{SAMPLE}} = 100$ kSPS; input filter = 15Ω , $C_L = 2$ nF Includes distortion and noise components Measured on adjacent channels
Total Harmonic Distortion	THD		-86		dB	
Peak Harmonic or Spurious Noise			-88		dB	
Channel-to-Channel Crosstalk			-90		dB	
ADC INPUT						
Input Voltage Ranges						At 1 MSPS ≤ 800 kSPS 500 kSPS, ADCCNVC, Bits[25:16] = 0x1E During ADC acquisition
Single-Ended Mode ¹		AGND		VREF		
Compliance ¹		AGND4		AVDD4		
Leakage Current			± 1.5		nA	
Input Current			± 9		$\mu\text{A}/\text{V}$	
			± 6		$\mu\text{A}/\text{V}$	
			± 4		$\mu\text{A}/\text{V}$	
Input Capacitance			20		pF	
ON-CHIP VOLTAGE REFERENCE						
Accuracy			2.51		V	0.47 μF from VREF_1V2 to AGND4; reference is measured with all ADC and VDACS enabled $T_A = 25^\circ\text{C}$
Reference Temperature Coefficient ¹			± 15	± 5	mV ppm/ $^\circ\text{C}$	
Power Supply Rejection Ratio	PSRR		60		dB	
Internal VREF Power-On Time			50		ms	

Parameter	Symbol	Min	Typ	Max	Unit	Test Conditions/Comments
EXTERNAL REFERENCE INPUT						
Range ¹		1.8		2.5	V	ADC
Input Current			200		μA	
BUFFERED REFERENCE OUTPUT						
Output Voltage			2.504		V	
Accuracy			±8		mV	T _A = 25°C, load = 1.2 mA
Reference Temperature Coefficient ¹			±15		μV/°C	100 nF from BUF_VREF2V5 to AGND4
Output Impedance			10		Ω	T _A = 25°C
Load Current ¹				1.2	mA	
VDAC CHANNEL SPECIFICATIONS						R _L = 5 kΩ, C _L = 100 pF ²
DC Accuracy ¹		12			Bits	1 LSB = 2.5 V/2 ¹²
Resolution ¹		12			Bits	Number of data bits
Relative Accuracy ³	INL		±4		LSB	1 LSB = 2.5 V/2 ¹²
Differential Nonlinearity ³	DNL			+1/-0.99	LSB	Guaranteed monotonic, 1 LSB = 2.5 V/2 ¹²
Offset Error			±3	±15	mV	2.5 V internal reference, DAC Output Code 0
Drift			±18		μV/°C	
Gain Error ⁴			±0.3	±0.85	%	0 V to internal V _{REF} range
Drift			±0.4	±1	%	0 V to AVDD range
Mismatch			6.5		ppm/°C	Excluding reference drift
Analog Outputs					%	% of full scale on DAC0
Output Voltage Range 1 ¹		0.15		2.5	V	
Output Voltage Range 2 ¹		0.15		AVDDx - 0.15	V	
Output Impedance			2		Ω	
DAC AC Characteristics						
Output Settling Time			10		μs	Settled to ±1 LSB
Glitch Energy			±20		nV-sec	1 LSB change when the maximum number of bits changes simultaneously in the DACxDAT register
COMPARATOR						
Input						
Offset Voltage			±10		mV	
Bias Current			1		nA	
Voltage Range ¹		AGNDx		AVDDx - 1.2	V	
Capacitance			7		pF	
Hysteresis ¹		8.5		15	mV	When enabled in software
Response Time			7		μs	AFECOMP, Bits[2:1] = 0
TEMPERATURE SENSOR						
Resolution			0.5		°C	Indicates die temperature, see Figure 9
Accuracy ¹		1.34		1.43	V	When precision calibrated by the user ⁵
						ADC measured voltage for temperature sensor channel without calibration, T _A = 25°C
POWER-ON RESET	POR		2.85	2.9	V	
WATCHDOG TIMER	WDT					
Timeout Period			32		sec	Default at power-up
FLASH/EE MEMORY						
Endurance ¹		10,000			Cycles	
Data Retention ¹		20			Years	T _J = 85°C

Parameter	Symbol	Min	Typ	Max	Unit	Test Conditions/Comments
DIGITAL INPUTS						
Input Leakage Current						
Logic 1 GPIO			1		nA	$V_{IH} = V_{DD}$, pull-up resistor disabled
Logic 0 GPIO			10		nA	$V_{IL} = 0\text{ V}$, pull-up resistor disabled
PRTADDRx						
Input Leakage Current			16		μA	$V_{IN} = 0\text{ V}$ to 1.8 V, due to weak pull-up resistors to 1.8 V
Input Voltage		0.84		1.5	V	External resistor $91\text{ k}\Omega \pm 1\%$ to ground; range for CFP MSA high ¹
Input Capacitance, All Balls Except MCK, MDIO, PRTADDRx, and XTALx			10		pF	
Input Capacitance						
MCK, PRTADDRx			6.5		pF	
MDIO			8.5		pF	
Ball Capacitance						
XTALI			5		pF	
XTALO			5		pF	
LOGIC INPUTS						
GPIO Input Voltage						
Low	V_{INL}			$0.25 \times IOVDDx$	V	
High	V_{INH}	$0.58 \times IOVDDx$			V	
MDIO						
PRTADDRx Input Voltage						
Low	V_{INL}			0.36	V	
High	V_{INH}	0.84			V	
MCK, MDIO Input Voltage						
Low	V_{INL}			0.36	V	
High	V_{INH}	0.84			V	
XTALI Input Voltage						
Low	V_{INL}		1.1		V	
High	V_{INH}		1.7		V	
Pull-Up Current		30		120	μA	$V_{IN} = 0\text{ V}$, see Figure 10
Pull-Down Current		30		100	μA	$V_{IN} = 3.3\text{ V}$, see Figure 10
LOGIC OUTPUTS						
All digital outputs excluding XTALO						
GPIO Output Voltage ⁶						
High	V_{OH}	$IOVDDx - 0.4$			V	$I_{SOURCE} = 2\text{ mA}$
Low	V_{OL}			0.4	V	$I_{SINK} = 2\text{ mA}$
GPIO Short-Circuit Current ¹			11		mA	See Figure 11
MDIO						
Output Voltage						
High	V_{OH}	1.0			V	$I_{SOURCE} = 4\text{ mA}$
Low	V_{OL}			0.2	V	$I_{SINK} = 4\text{ mA}$
Delay Time				100	ns	MCK to MDIO out
OSCILLATORS						
Internal System Oscillator			16		MHz	
Accuracy			± 0.5	± 3	%	
System PLL			80		MHz	Main system clock
External Crystal Oscillator			16		MHz	Can be selected in place of the internal oscillator
32 kHz Internal Oscillator			32.768		kHz	Use for watchdog
Accuracy			± 5	± 20	%	
External Clock		0.05		80	MHz	Can be selected in place of PLL
START-UP TIME						
At Power-On			40		ms	Processor clock = 80 MHz
After Other Reset			1.5		ms	POR to first user code execution
From All Power-Down Modes			1.25		μs	Reset to first user code execution

Parameter	Symbol	Min	Typ	Max	Unit	Test Conditions/Comments
PROGRAMMABLE LOGIC ARRAY	PLA					
Propagation Delay						
Ball			17		ns	From input ball to output ball
Element			1.5		ns	Per PLA cell
EXTERNAL INTERRUPTS						
Pulse Width ¹						
Level Triggered		7			ns	
Edge Triggered		1			ns	
POWER REQUIREMENTS ⁷						
Power Supply Voltage Range						
AVDDx to AGNDx and IOVDDx to DGNDx ¹		2.9	3.3	3.6	V	
Analog Power Supply Currents						
AVDDx Current			4.9		mA	Analog peripherals in idle mode
Digital Power Supply Current						
IOVDDx Current in Normal Mode			2.7		mA	All GPIO pull-up resistors enabled
VDDx Current						
Normal Mode			29		mA	Clock divider (CD) = 0 (80 MHz clock), executing typical code
			20		mA	CD = 1, executing typical code
			10		mA	CD = 7, executing typical code
CORE_SLEEP Mode			16		mA	
SYS_SLEEP Mode			8		mA	
Hibernate Mode			4		mA	
Additional Power Supply Currents						
ADC			4.1		mA	Continuously converting at 100 kSPS
DAC			340		μA	Per powered up DAC, excluding load current
Total Supply Current			37		mA	VDD1, IOVDDx, AVDDx connected together; condition when entering user code: peripheral clocks on, peripherals idle, no load currents
Thermal Performance						
Impedance Junction to Ambient			45		°C/W	JEDEC 2S2P

¹ These specifications are not production tested but are guaranteed by design and/or characterization data at production release.

² The data in this section also applies for a load of $R_L = 1 \text{ k}\Omega$ and $C_L = 100 \text{ pF}$ but only an output range of 0 V to 2.5 V. However, this specification is not production tested.

³ DAC linearity is calculated using a reduced code range of 100 to 3900.

⁴ DAC gain error is calculated using a reduced code range of 100 to an internal 2.5 V V_{REF} .

⁵ Due to self heating, internal temperature measurements cannot be used to predict external temperatures. This value is only relevant after user calibration and only for internal and external conditions identical to those at calibration.

⁶ The average current from all GPIO balls must not exceed 3 mA per ball.

⁷ Power figures exclude any load currents to external circuits.

TIMING SPECIFICATIONS

I²C Timing

Table 2. I²C Timing in Standard Mode (100 kHz)

Parameter	Description	Slave			Unit
		Min	Typ	Max	
t _L	SCL low pulse width	4.7			μs
t _H	SCL high pulse width	4.0			ns
t _{SHD}	Start condition hold time	4.0			μs
t _{DSU}	Data setup time	250			ns
t _{DHD}	Data hold time (SDA held internally for 300 ns after falling edge of SCL)	0		3.45	μs
t _{RSU}	Setup time for repeated start	4.7			μs
t _{PSU}	Stop condition setup time	4.0			μs
t _{BUF}	Bus-free time between a stop condition and a start condition	4.7			μs
t _R	Rise time for both SLC and SDA			1	μs
t _F	Fall time for both SLC and SDA		15	300	ns
t _{VD;DAT}	Data valid time			3.45	μs
t _{VD;ACK}	Data valid acknowledge time			3.45	μs

Table 3. I²C Timing in Fast Mode (400 kHz)

Parameter	Description	Slave			Unit
		Min	Typ	Max	
t _L	SCL low pulse width	1.3			μs
t _H	SCL high pulse width	0.6			ns
t _{SHD}	Start condition hold time	0.3			μs
t _{DSU}	Data setup time	100			ns
t _{DHD}	Data hold time (SDA held internally for 300 ns after falling edge of SCL)	0			μs
t _{RSU}	Setup time for repeated start	0.6			μs
t _{PSU}	Stop condition setup time	0.3			μs
t _{BUF}	Bus-free time between a stop condition and a start condition	1.3			μs
t _R	Rise time for both SCL and SDA	20		300	ns
t _F	Fall time for both SCL and SDA		15	300	ns
t _{VD;DAT}	Data valid time			0.9	μs
t _{VD;ACK}	Data valid acknowledge time			0.9	μs

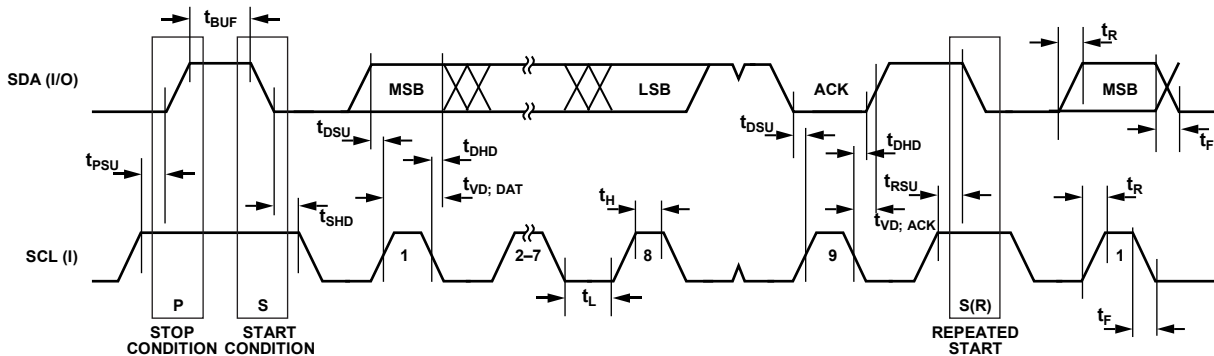

Figure 2. I²C Compatible Interface Timing

13986-010

SPI Timing

Table 4. SPI Master Mode Timing (Phase Mode = 1)

Parameter	Description	Min	Typ	Max	Unit
t_{SL}	SCLK low pulse width		$(SPIDIV + 1) \times t_{HCLK}/2$		ns
t_{SH}	SCLK high pulse width		$(SPIDIV + 1) \times t_{HCLK}/2$		ns
t_{DAV}	Data output valid after SCLK edge	0	3		ns
t_{DSU}	Data input setup time before SCLK edge		$\frac{1}{2}$ SCLK		ns
t_{DHD}	Data input hold time after SCLK edge		SCLK		ns
t_{DF}	Data output fall time		SCLK		ns
t_{DR}	Data output rise time		25		ns
t_{SR}	SCLK rise time		25		ns
t_{SF}	SCLK fall time		20		ns

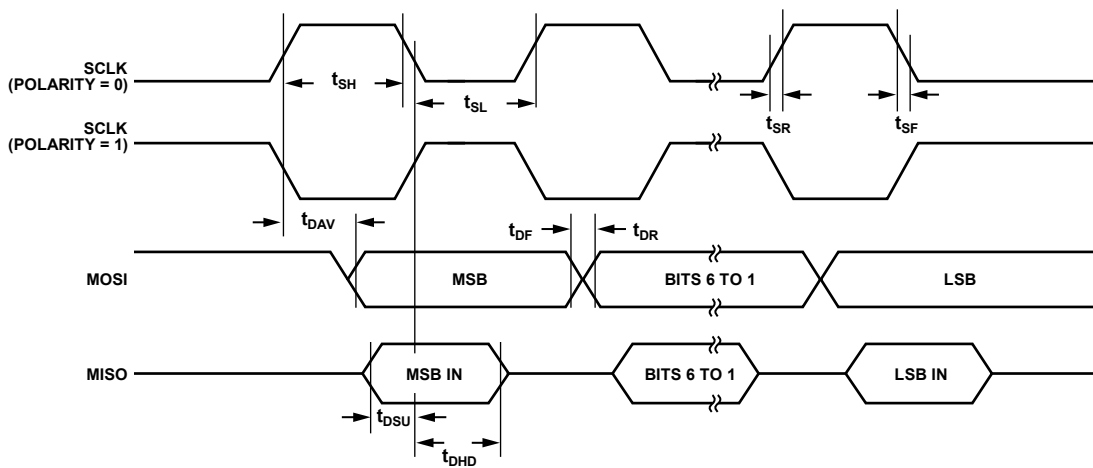

Figure 3. SPI Master Mode Timing (Phase Mode = 1)

13886-011

Table 5. SPI Master Mode Timing (Phase Mode = 0)

Parameter	Description	Min	Typ	Max	Unit
t_{SL}	SCLK low pulse width		$(SPIDIV + 1) \times t_{HCLK}/2$		ns
t_{SH}	SCLK high pulse width		$(SPIDIV + 1) \times t_{HCLK}/2$		ns
t_{DAV}	Data output valid after SCLK edge	0	3		ns
t_{DOSU}	Data output setup before SCLK edge		$\frac{1}{2}$ SCLK		ns
t_{DSU}	Data input setup time before SCLK edge		SCLK		ns
t_{DHD}	Data input hold time after SCLK edge		SCLK		ns
t_{DF}	Data output fall time		25		ns
t_{DR}	Data output rise time		25		ns
t_{SR}	SCLK rise time		20		ns
t_{SF}	SCLK fall time		20		ns

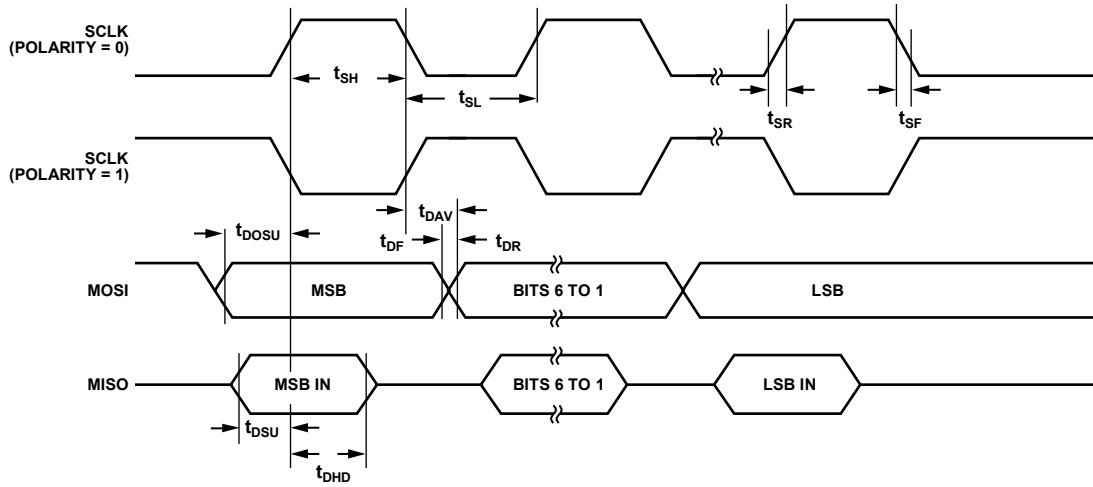

Figure 4. SPI Master Mode Timing (Phase Mode = 0)

13886-012

Table 6. SPI Slave Mode Timing (Phase Mode = 1)

Parameter	Description	Min	Typ	Max	Unit
$t_{\overline{CS}}$	\overline{CS} to SCLK edge	10			ns
$t_{\overline{CSM}}$	\overline{CS} high time between active periods	SCLKx			ns
t_{SL}	SCLK low pulse width		$(SPIDIV + 1) \times t_{HCLK}$		ns
t_{SH}	SCLK high pulse width		$(SPIDIV + 1) \times t_{HCLK}$		ns
t_{DAV}	Data output valid after SCLK edge		20		ns
t_{DSU}	Data input setup time before SCLK edge	10			ns
t_{DHD}	Data input hold time after SCLK edge	10			ns
t_{DF}	Data output fall time		25		ns
t_{DR}	Data output rise time		25		ns
t_{SR}	SCLK rise time	1			ns
t_{SF}	SCLK fall time	1			ns
t_{SFS}	\overline{CS} high after SCLK edge	20			ns

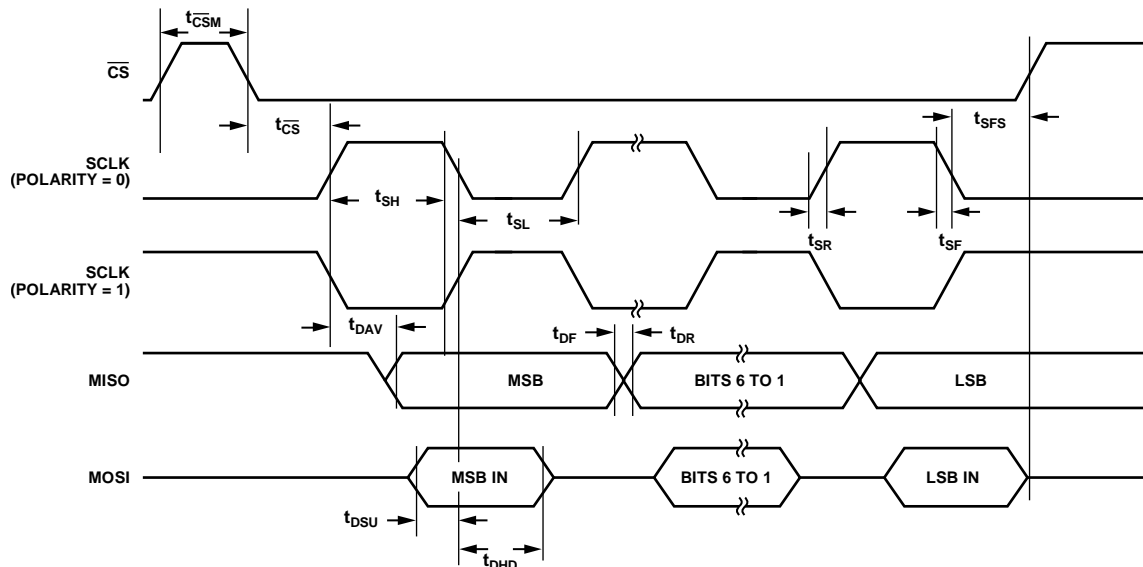

Figure 5. SPI Slave Mode Timing (Phase Mode = 1)

13986-013

Table 7. SPI Slave Mode Timing (Phase Mode = 0)

Parameter	Description	Min	Typ	Max	Unit
$t_{\overline{CS}}$	\overline{CS} to SCLK edge	10			ns
$t_{\overline{CSM}}$	\overline{CS} high time between active periods	SCLKx			ns
t_{SL}	SCLK low pulse width		$(SPIDIV + 1) \times t_{HCLK}$		ns
t_{SH}	SCLK high pulse width		$(SPIDIV + 1) \times t_{HCLK}$		ns
t_{DAV}	Data output valid after SCLK edge		20		ns
t_{DSU}	Data input setup time before SCLK edge	10			ns
t_{DHD}	Data input hold time after SCLK edge	10			ns
t_{DF}	Data output fall time		25		ns
t_{DR}	Data output rise time		25		ns
t_{SR}	SCLK rise time	1			ns
t_{SF}	SCLK fall time	1			ns
t_{DOCS}	Data output valid after \overline{CS} edge	20			ns
t_{SFS}	\overline{CS} high after SCLK edge	10			ns

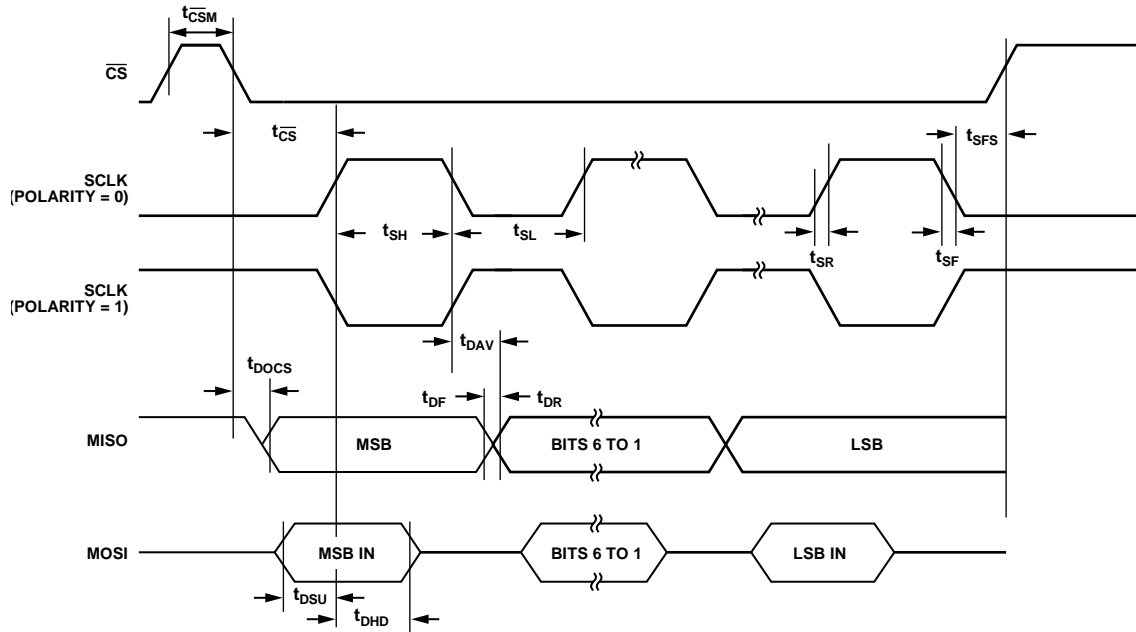

Figure 6. SPI Slave Mode Timing (Phase Mode = 0)

13986-014

Table 8. MDIO vs. MDC Timing

Parameter	Description	Min	Typ	Max	Unit
t_{SETUP}	MDIO setup before MCK edge	10			ns
t_{HOLD}	MDIO valid after MCK edge	10			ns
t_{DELAY}	Data output after MCK edge			100	ns

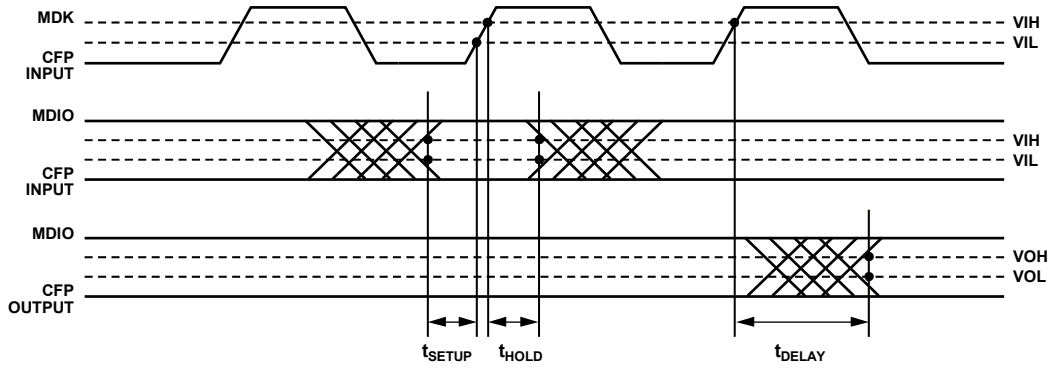

Figure 7. MDIO Timing

13886-015

ABSOLUTE MAXIMUM RATINGS

Table 9.

Parameter	Rating
Any Ball to GND	-0.3 V to +3.9 V
Any RES1 Type Ball to GND	-0.3 V to +2.8 V
MDIO, ¹ MCK and PRTADDR0 to PRTADDR4 in MDIO Mode to GND	-0.3 V to +2.1 V
Between Any of AVDDx, IOVDDx, and VDD1 Balls	-0.3 V to +0.3 V
Any I Type Ball to GND ²	-0.3 V to IOVDDx + 0.3 V
Any RES Type, AI Type, or AO Type Ball to GND ³	-0.3 V to AVDDx + 0.3 V
ADC_REFP to GND	-0.3 V to AVDDx + 0.3 V
Total Positive GPIO Ball Currents	0 mA to 30 mA
Total Negative GPIO Ball Currents	-30 mA to 0 mA
Maximum Power Dissipation	1 W
Operating Ambient Temperature Range	-40°C to +105°C
Storage Temperature Range	-65°C to +160°C
Operating Junction Temperature Range	-40°C to +120°C
Electrostatic Discharge (ESD)	
Human Body Model (HBM)	2 kV
Field Induced Charged Device Mode (FICDM)	1 kV

¹ Note this ball is always in MDIO mode.

² This limit does not apply if no current can be drawn by external circuits on IOVDDx, because then IOVDD follows to a suitable level.

³ This limit does not apply if no current can be drawn by external circuits on AVDDx, because then AVDD follows to a suitable level.

Stresses at or above those listed under Absolute Maximum Ratings may cause permanent damage to the product. This is a stress rating only; functional operation of the product at these or any other conditions above those indicated in the operational section of this specification is not implied. Operation beyond the maximum operating conditions for extended periods may affect product reliability.

All requirements applicable to each ball must be met. Where multiple limits apply to a ball, each one must be met individually. The limits apply according to the functionality of the balls at the time. Balls that can be either analog or digital, that is, that have two types indicated in the ball descriptions, must meet the limits for both types. For ball types, see Table 10.

When powered up, it is required that all ground balls and ADC_REFN be connected together to a node referred to as GND in Table 9. The limits that are listed must be reduced by any difference between any GNDs. Also, it is required that AVDD3 is connected to AVDD4 and that IOVDD1 to IOVDD3 are connected together.

ESD CAUTION

ESD (electrostatic discharge) sensitive device. Charged devices and circuit boards can discharge without detection. Although this product features patented or proprietary protection circuitry, damage may occur on devices subjected to high energy ESD. Therefore, proper ESD precautions should be taken to avoid performance degradation or loss of functionality.

PIN CONFIGURATION AND FUNCTION DESCRIPTIONS

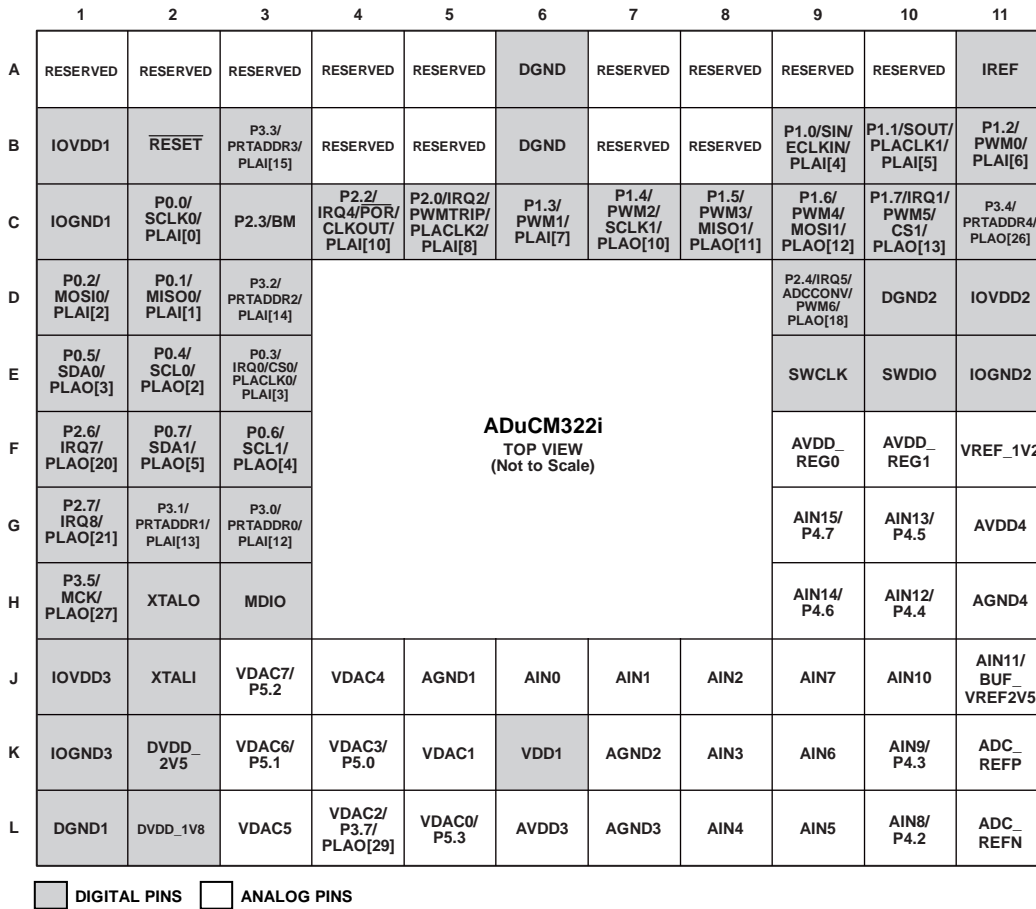

Figure 8. Pin Configuration

1398B-002

Table 10. Pin Function Descriptions

Pin No.	Mnemonic	Type ¹	Description
A1	RESERVED	RES	No Connect. Leave this ball unconnected.
A2	RESERVED	RES	Connect to AGND.
A3	RESERVED	RES1	Connect to AVDD_REG1.
A4	RESERVED	RES1	Connect to AVDD_REG1.
A5	RESERVED	RES	Connect to AGND.
A6	DGND	S	Power Supply Ground.
A7	RESERVED	RES	Connect to AGND.
A8	RESERVED	RES1	Connect to AVDD_REG1.
A9	RESERVED	RES1	Connect to AVDD_REG1.
A10	RESERVED	RES	Connect to AGND.
A11	IREF	AI	Reference Current. This ball generates the reference current and is set by an external resistor, R _{EXT} . Connect a 3.3 kΩ R _{EXT} from IREF to DGND.
B1	IOVDD1	S	3.3 V GPIO Supply.
B2	RESET	I	Reset Input (Active Low). An internal pull-up resistor is included.
B3	P3.3/PRTADDR3/PLAI[15]	I/O	Digital Input/Output Port 3.3 (P3.3). MDIO Port Address Bit 3 (PRTADDR3). See the Digital Inputs parameter in Table 1 for details. Output of PLA Element 15 (PLAI[15]).
B4	RESERVED	RES	No Connect. Leave this ball unconnected.
B5	RESERVED	RES	No Connect. Leave this ball unconnected.
B6	DGND	S	Power Supply Ground.

Pin No.	Mnemonic	Type ¹	Description
B7	RESERVED	RES	No Connect. Leave this ball unconnected.
B8	RESERVED	RES	No Connect. Leave this ball unconnected.
B9	P1.0/SIN/ECLKIN/PLAI[4]	I/O	Digital Input/Output Port 1.0 (P1.0). UART Input (SIN). External Input Clock (ECLKIN). Input to PLA Element 4 (PLAI[4]).
B10	P1.1/SOUT/PLACK1/PLAI[5]	I/O	Digital Input/Output Port 1.1 (P1.1). UART Output (SOUT). PLA Clock 1(PLACK1). Input to PLA Element 5 (PLAI[5]).
B11	P1.2/PWM0/PLAI[6]	I/O	Digital Input/Output Port 1.2 (P1.2). PWM Output 0 (PWM0). Input to PLA Element 6 (PLAI[6]).
C1	IOGND1	S	Ground for IOVDD1.
C2	P0.0/SCLK0/PLAI[0]	I/O	Digital Input/Output Port 0.0 (P0.0). SPI0 Clock (SCLK0). Input to PLA Element 0 (PLAI[0]).
C3	P2.3/BM	I/O	Digital Input/Output Port 2.3 (P2.3). Boot Mode (BM). This ball determines the start-up sequence after every reset. Pull-up is enabled at power-up.
C4	P2.2/IRQ4/ $\overline{\text{POR}}$ /CLKOUT/PLAI[10]	I/O	Digital Input/Output Port 2.2 (P2.2). External Interrupt 4 (IRQ4). Reset Output ($\overline{\text{POR}}$). This ball function is an output and it is the default for Ball C4. Clock Output (CLKOUT). Input to PLA Element 10 (PLAI[10]).
C5	P2.0/IRQ2/PWMTRIP/PLACK2/PLAI[8]	I/O	Digital Input/Output Port 2.0 (P2.0). External Interrupt 2 (IRQ2). PWM Trip (PWMTRIP). PLA Input Clock 2 (PLACK2). Input to PLA Element 8 (PLAI[8]).
C6	P1.3/PWM1/PLAI[7]	I/O	Digital Input/Output Port 1.3 (P1.3). PWM Output 1 (PWM1). Input to PLA Element 7 (PLAI[7]).
C7	P1.4/PWM2/SCLK1/PLAO[10]	I/O	Digital Input/Output Port 1.4 (P1.4). PWM Output 2 (PWM2). SPI1 Clock (SCLK1). Output of PLA Element 10 (PLAO[10]).
C8	P1.5/PWM3/MISO1/PLAO[11]	I/O	Digital Input/Output Port 1.5 (P1.5). PWM Output 3 (PWM3). SPI1 Master In, Slave Out (MISO1). Output of PLA Element 11 (PLAO[11]).
C9	P1.6/PWM4/MOSI1/PLAO[12]	I/O	Digital Input/Output Port 1.6 (P1.6). PWM Output 4 (PWM4). SPI1 Master Out, Slave Input (MOSI1). Output of PLA Element 12 (PLAO[12]).
C10	P1.7/IRQ1/PWM5/CS1/PLAO[13]	I/O	Digital Input/Output Port 1.7 (P1.7). External Interrupt 1 (IRQ1). PWM Output 5 (PWM5). SPI1 Chip Select 1 (CS1). When using SPI1, configure this ball as CS1. Output of PLA Element 13 (PLAO[13]).

Pin No.	Mnemonic	Type ¹	Description
C11	P3.4/PRTADDR4/PLAO[26]	I/O	Digital Input/Output Port 3.4 (P3.4). MDIO Port Address Bit 4 (PRTADDR4). See the Digital Inputs parameter in Table 1 for details. Output of PLA Element 26 (PLAO[26]).
D1	P0.2/MOSI0/PLAI[2]	I/O	Digital Input/Output Port 0.2 (P0.2). SPI0 Master Out, Slave In (MOSI0). Input to PLA Element 2 (PLAI[2]).
D2	P0.1/MISO0/PLAI[1]	I/O	Digital Input/Output Port 0.1 (P0.1). SPI0 Master In, Slave Out (MISO0). Input to PLA Element 1 (PLAI[1]).
D3	P3.2/PRTADDR2/PLAI[14]	I/O	Digital Input/Output Port 3.2 (P3.2). MDIO Port Address Bit 2 (PRTADDR2). See the Digital Inputs parameter in Table 1 for details. Input to PLA Element 14 (PLAI[14]).
D9	P2.4/IRQ5/ADCCONV/PWM6/PLAO[18]	I/O	Digital Input/Output Port 2.4 (P2.4). External Interrupt 5 (IRQ5). External Input to Start ADC Conversions (ADCCONV). PWM Output 6 (PWM6). Output of PLA Element 18 (PLAO[18]).
D10	DGND2	S	Digital Ground 2. Connect to DGND1.
D11	IOVDD2	S	3.3 V GPIO Supply.
E1	P0.5/SDA0/PLAO[3]	I/O	Digital Input/Output Port 0.5 (P0.5). I ² C0 Serial Data (SDA0). Output of PLA Element 3 (PLAO[3]).
E2	P0.4/SCL0/PLAO[2]	I/O	Digital Input/Output Port 0.4 (P0.4). I ² C0 Serial Clock (SCL0). Output of PLA Element 2 (PLAO[2]).
E3	P0.3/IRQ0/CS0/PLACLK0/PLAI[3]	I/O	Digital Input/Output Port 0.3 (P0.3). External Interrupt 0 (IRQ0). SPI0 Chip Select 0 (CS0). When using SPI0, configure this ball as CS0. PLA Clock 0 (PLACLK0). Input to PLA Element 3 (PLAI[3]).
E9	SWCLK	I	Serial Wire Debug Clock.
E10	SWDIO	I/O	Serial Wire Bidirectional Data.
E11	IOGND2	S	Ground for IOVDD2.
F1	P2.6/IRQ7/PLAO[20]	I/O	Digital Input/Output Port 2.6 (P2.6). External Interrupt 7 (IRQ7). Output of PLA Element 20 (PLAO[20]).
F2	P0.7/SDA1/PLAO[5]	I/O	Digital Input/Output Port 0.7 (P0.7). I ² C1 Serial Data (SDA1). Output of PLA Element 5 (PLAO[5]).
F3	P0.6/SCL1/PLAO[4]	I/O	Digital Input/Output Port 0.6 (P0.6). I ² C1 Serial Clock (SCL1). Output of PLA Element 4 (PLAO[4]).
F9	AVDD_REG0	AO	Analog Regulator 0 Supply. A 470 nF capacitor to AGND4 must be connected to this ball to stabilize the internal 2.5 V regulator that supplies the ADC.
F10	AVDD_REG1	AO	Analog Regulator 1 Supply. Output of 2.5 V on-chip LDO regulator. A 470 nF capacitor to AGND4 must be connected to this ball.
F11	VREF_1V2	S	1.2 V Reference. This ball cannot be used to source current externally. Connect VREF_1V2 to AGNDx via a 470 nF capacitor.
G1	P2.7/IRQ8/PLAO[21]	I/O	Digital Input/Output Port 2.7 (P2.7). External Interrupt 8 (IRQ8). Output of PLA Element 21 (PLAO[21]).

Pin No.	Mnemonic	Type ¹	Description
G2	P3.1/PRTADDR1/PLAI[13]	I/O	Digital Input/Output Port 3.1 (P3.1). MDIO Port Address Bit 1 (PRTADDR1). See the Digital Inputs parameter in Table 1 for details. Input to PLA Element 13 (PLAI[13]).
G3	P3.0/PRTADDR0/PLAI[12]	I/O	Digital Input/Output Port 3.0 (P3.0). MDIO Port Address Bit 0 (PRTADDR0). See the Digital Inputs parameter in Table 1 for details. Input to PLA Element 12 (PLAI[12]).
G9	AIN15/P4.7	AI/I/O	Analog Input 15 (AIN15). Digital Input/Output Port 4.7 (P4.7).
G10	AIN13/P4.5	AI/I/O	Analog Input 13 (AIN13). Digital Input/Output Port 4.5 (P4.5).
G11	AVDD4	S	ADC Supply (3.3 V).
H1	P3.5/MCK/PLAO[27]	I/O	Digital Input/Output Port 3.5 (P3.5). MDIO Clock (MCK). See the Digital Inputs parameter in Table 1 for more details. Output of PLA Element 27 (PLAO[27]).
H2	XTALO	O	Output from the Crystal Oscillator Inverter. When not using an external crystal, leave XTALO unconnected.
H3	MDIO	I/O	MDIO Data.
H9	AIN14/P4.6	AI/I/O	Analog Input 14 (AIN14). Digital Input/Output Port 4.6 (P4.6).
H10	AIN12/P4.4	AI/I/O	Analog Input 12 (AIN12). Digital Input/Output Port 4.4 (P4.4).
H11	AGND4	S	Ground for AVDD4, AVDD_REG0, and AVDD_REG1.
J1	IOVDD3	S	3.3 V GPIO Supply.
J2	XTALI	I	Input to the Crystal Oscillator Inverter and Input to the Internal Clock Generator Circuits. When not using an external crystal, connect XTALI to DGND.
J3	VDAC7/P5.2	AO/I/O	Voltage DAC7 Output (VDAC7). Digital Input/Output Port 5.2 (P5.2).
J4	VDAC4	AO	Voltage DAC4 Output (VDAC4).
J5	AGND1	S	Analog Ground for VDD1.
J6	AIN0	AI	Analog Input 0.
J7	AIN1	AI	Analog Input 1.
J8	AIN2	AI	Analog Input 2.
J9	AIN7	AI	Analog Input 7.
J10	AIN10	AI	Analog Input 10.
J11	AIN11/BUF_VREF2V5	AI/AO	Analog Input 11 (AIN11). Buffered 2.5 V Bias (BUF_VREF2V5). The maximum load is 1.2 mA. Connect BUF_VREF2V5 to AGNDx via a 100 nF capacitor.
K1	IOGND3	S	Ground for IOVDD3.
K2	DVDD_2V5	AO	2.5 V Digital Supply. A 470 nF capacitor to IOGND3 must be connected to this ball to stabilize the internal 2.5 V regulator that supplies the analog digital control.
K3	VDAC6/P5.1	AO/I/O	Voltage DAC6 Output (VDAC6). Digital Input/Output Port 5.1 (P5.1).
K4	VDAC3/P5.0	AO/I/O	Voltage DAC3 Output (VDAC3). Digital Input/Output Port 5.0 (P5.0).
K5	VDAC1	AO	Voltage DAC1 Output.
K6	VDD1	S	3.3 V Supply for Digital Die.
K7	AGND2	S	ESD Ground for Pad Ring.
K8	AIN3	AI	Analog Input 3.
K9	AIN6	AI	Analog Input 6. AIN6 is also the positive input for the comparator.
K10	AIN9/P4.3	AI/I/O	Analog Input 9 (AIN9). Digital Input/Output Port 4.3 (P4.3).

Pin No.	Mnemonic	Type ¹	Description
K11	ADC_REFP	AO/A	Decoupling Capacitor Connection for ADC Reference Buffer. Connect this ball to a 4.7 μ F capacitor to the ADC_REFN ball. ADC_REFP can be overdriven by an external reference.
L1	DGND1	S	Digital Ground 1 for DVDD_1V8.
L2	DVDD_1V8	AO	1.8 V Digital Supply. A 470 nF capacitor to DGND1 must be connected to this ball to stabilize the internal 1.8 V regulator that supplies flash memory and the ARM Cortex-M3 processor.
L3	VDAC5	AO	Voltage DAC5 Output (VDAC5).
L4	VDAC2/P3.7/PLAO[29]	AO/I/O	Voltage DAC2 Output (VDAC2). Digital Input/Output Port 3.7 (P3.7). Output of PLA Element 29 (PLAO[29]).
L5	VDAC0/P5.3	AO/I/O	Voltage DAC0 Output (VDAC0). Digital Input/Output Port 5.3 (P5.3).
L6	AVDD3	S	VDAC Supply (3.3 V).
L7	AGND3	S	Ground for AVDD3.
L8	AIN4	AI	Analog Input 4.
L9	AIN5	AI	Analog Input 5. AIN5 can be the negative input for the comparator.
L10	AIN8/P4.2	AI/I/O	Analog Input 8 (AIN8). Digital Input/Output Port 4.2 (P4.2).
L11	ADC_REFN	AO/A	Decoupling Capacitor Connection for ADC Reference Buffer. Connect this ball to AGND4.

¹ RES and RES1 are reserved, S is supply, AI is analog input, I is digital input, I/O is input/output, AO is analog output, and O is digital output.

TYPICAL PERFORMANCE CHARACTERISTICS

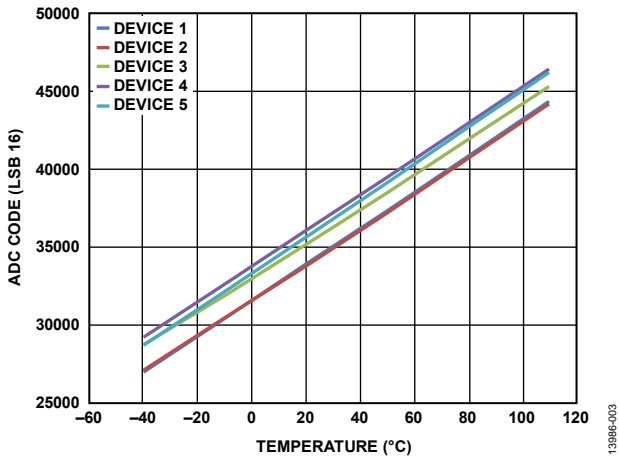

Figure 9. Temperature Measurement vs. Internal Temperature ($V_{DD} = 3.3\text{ V}$, 50 kSPS)

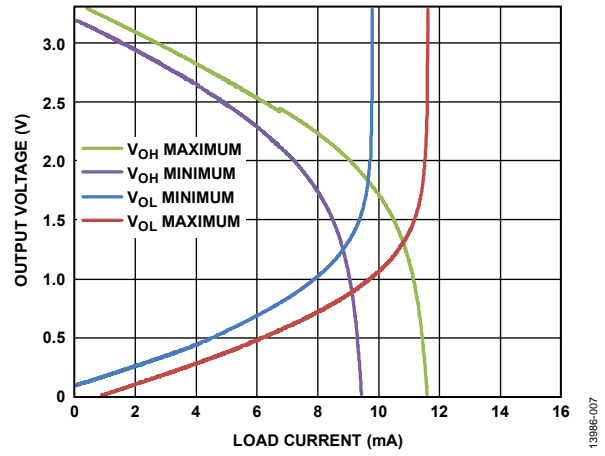

Figure 11. Output Voltage vs. Load Current

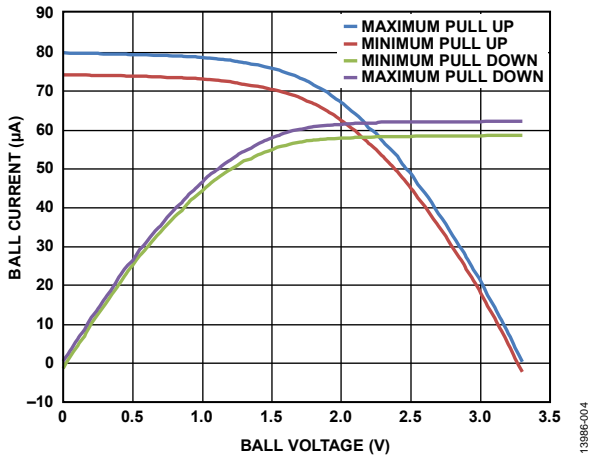

Figure 10. Pull-Up/Pull-Down Ball Current vs. Ball Voltage ($V_{DD} = 3.3\text{ V}$, $T_A = 25^\circ\text{C}$)

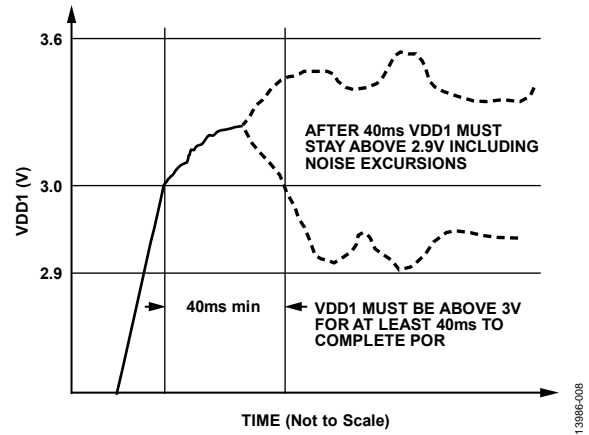

Figure 12. VDD1 Power-On Requirements

APPLICATIONS INFORMATION

RECOMMENDED CIRCUIT AND COMPONENT VALUES

Figure 13 shows a typical connection diagram for the [ADuCM322i](#).

Supplies and regulators must be adequately decoupled with capacitors connected between the AVDD_x, DVDD_x, AVDD_REG_x, IOVDD_x, and VDD1 balls and their associated GND balls (AGND_x, IOGND_x, and DGND_x). Table 10 indicates which ground balls are paired with which supply balls.

There are four digital supply balls: IOVDD1, IOVDD2, IOVDD3, and VDD1. Decouple these balls with a 100 nF capacitor placed as near as possible to each of the four balls and their associated ground balls (IOGND_x and AGND1, respectively). In addition, place a 10 μF capacitor conveniently near to these balls.

Similarly, the analog supply balls, AVDD3 and AVDD4, each require a 100 nF capacitor placed as near as possible to each ball and its associated AGND_x ball, and place a 10 μF capacitor conveniently near to these balls.

The ADC reference requires a 4.7 μF capacitor placed between ADC_REFP and ADC_REFN and located as near as possible to each ball. ADC_REFN must be connected directly to AGND4.

The [ADuCM322i](#) contains four internal regulators. These regulators require external decoupling capacitors. The DVDD_1V8 and DVDD_2V5 balls each require a 470 nF capacitor to DGND1 and IOGND3, respectively. AVDD_REG0 and AVDD_REG1 each require a decoupling capacitor to AGND4. The AVDD_REG1 output ball must be connected to Ball A3, Ball A4, Ball A8, and Ball A9.

Connect the IREF ball to DGND via a standard 3.3 kΩ resistor.

Take care in the layout to ensure that currents flowing from the ground end of each decoupling capacitor to its associated ground ball share as little track as possible with other ground currents on the printed circuit board.

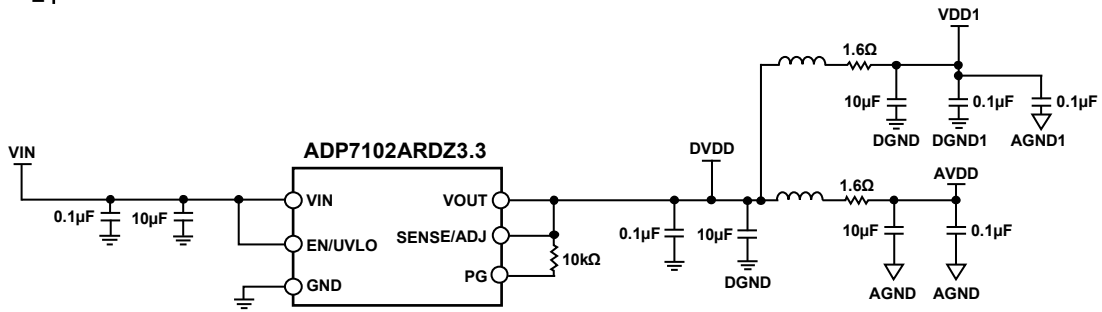
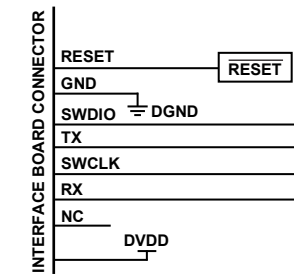
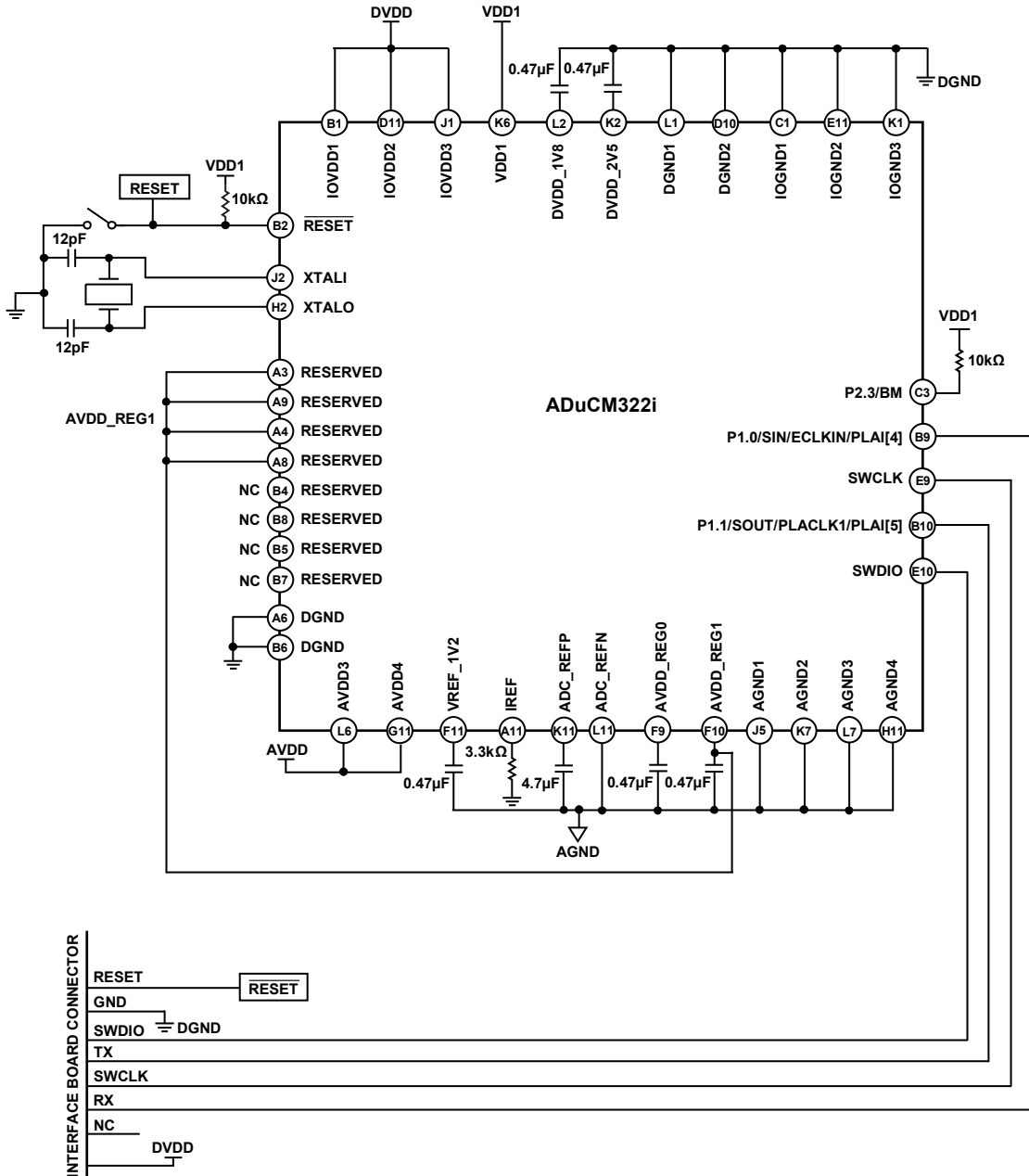
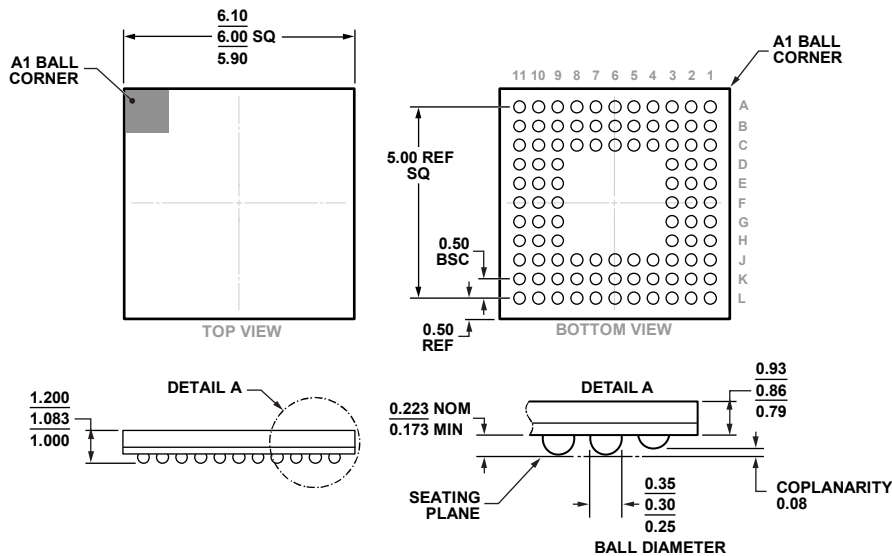

Figure 13. Recommended Circuit and Component Values

13986-009

PACKAGING AND ORDERING INFORMATION

OUTLINE DIMENSIONS



COMPLIANT TO JEDEC STANDARDS MO-195-AC
WITH THE EXCEPTION TO BALL COUNT.

Figure 14. 96-Ball Chip Scale Package Ball Grid Array [CSP_BGA] (BC-96-2)

Dimensions shown in millimeters

04-02-2013-A

ORDERING GUIDE



Model ¹	Temperature Range	Package Description	Package Option	Downloader	Ordering Quantity
ADuCM322BBCZI	-40°C to +105°C	96-Ball CSP_BGA	BC-96-2	I ² C	429
ADuCM322BBCZI-RL	-40°C to +105°C	96-Ball CSP_BGA	BC-96-2	I ² C	2500

¹ Z = RoHS Compliant Part.

I²C refers to a communications protocol originally developed by Philips Semiconductors (now NXP Semiconductors).

Looking for pricing, stock, or lifecycle information?

Click below to explore more details on WIN SOURCE:

-  [View ADUCM322BBCZI-RL on WIN SOURCE](#)
-  [Analog Devices Inc. Information](#)

Optimize Your Supply Chain with WIN SOURCE Solutions

-  Global Sourcing Solution
-  Obsolete Management
-  Cost Control Management
-  Shortage Management
-  Alternative Solution
-  Excess Inventory Management