



**THE DATASHEET OF  
PCF8576DU/2DA/2,02**





# PCF8576D

40 × 4 universal LCD driver for low multiplex rates

Rev. 15.1 — 1 September 2021

Product data sheet

## 1 General description

The PCF8576D is a peripheral device which interfaces to almost any Liquid Crystal Display (LCD)<sup>1</sup> with low multiplex rates. It generates the drive signals for any static or multiplexed LCD containing up to four backplanes and up to 40 segments. It can be easily cascaded for larger LCD applications. The PCF8576D is compatible with most microcontrollers and communicates via the two-line bidirectional I<sup>2</sup>C-bus. Communication overheads are minimized by a display RAM with auto-incremented addressing, by hardware subaddressing and by display memory switching (static and duplex drive modes).

- PCF8576DT/2 should not be used for new design-ins. Replacement part is PCF85176T/1 for industrial applications
- PCF8576DT/S400/2 should not be used for new design-ins. Replacement part is PCA85176T/Q900/1 for automotive applications

For a selection of NXP LCD segment drivers, see [Table 29](#).

## 2 Features and benefits

- AEC-Q100 compliant (PCF8576DT/S400/2) for automotive applications
- Single chip LCD controller and driver
- Selectable backplane drive configuration: static or 2, 3, 4 backplane multiplexing
- Selectable display bias configuration: static,  $\frac{1}{2}$ , or  $\frac{1}{3}$
- Internal LCD bias generation with voltage-follower buffers
- 40 segment drives:
  - Up to 20 7-segment numeric characters
  - Up to 10 14-segment alphanumeric characters
  - Any graphics of up to 160 segments/elements
- 40 × 4-bit RAM for display data storage
- Auto-incremented display data loading across device subaddress boundaries
- Display memory bank switching in static and duplex drive modes
- Versatile blinking modes
- Independent supplies possible for LCD and logic voltages
- Wide power supply range: from 1.8 V to 5.5 V
- Wide logic LCD supply range:
  - From 2.5 V for low-threshold LCDs
  - Up to 6.5 V for high-threshold twisted nematic LCDs
- Low power consumption
- 400 kHz I<sup>2</sup>C-bus interface
- May be cascaded for large LCD applications (up to 2 560 segments/elements possible)

<sup>1</sup> The definition of the abbreviations and acronyms used in this data sheet can be found in [Section 21](#).



- No external components required
- Compatible with chip-on-glass and chip-on-board technology
- Manufactured in silicon gate CMOS process

### 3 Ordering information

Table 1. Ordering information

Type number	Topside mark	Package		
		Name	Description	Version
PCF8576DT/2 <sup>[1]</sup>	PCF8576DT	TSSOP56	plastic thin shrink small outline package, 56 leads; body width 6.1 mm	SOT364-1
PCF8576DT/S400/2 <sup>[2]</sup>	PCF8576DT/S400	TSSOP56	plastic thin shrink small outline package, 56 leads; body width 6.1 mm	SOT364-1
PCF8576DU/DA/2	PC8576D-1	wire bond die	59 bonding pads	PCF8576DU/DA
PCF8576DU/2DA/2	PC8576D-2	bare die	59 bumps	PCF8576DU/2DA

[1] Not to be used for new designs. Replacement part is PCF85176T/1 for industrial applications.

[2] Not to be used for new designs. Replacement part is PCF85176T/Q900/1 for automotive applications.

Standard packing quantities and other packaging data are available at [www.nxp.com/packages/](http://www.nxp.com/packages/).

#### 3.1 Ordering options

Table 2. Ordering options

Type number	Orderable part number	Package	Packing method	Minimum order quantity	Temperature
PCF8576DT/2	PCF8576DT/2,118 <sup>[1]</sup>	TSSOP56	reel 13" q1 non dry pack	2000	T <sub>amb</sub> = -40 °C to +85 °C
	PCF8576DT/2,518	TSSOP56	reel 13" q1 dry pack	2000	T <sub>amb</sub> = -40 °C to +85 °C
PCF8576DT/S400/2	PCF8576DT/S400/2,1 <sup>[2]</sup>	TSSOP56	reel 13" q1 non dry pack	2000	T <sub>amb</sub> = -40 °C to +85 °C
	PCF8576DT/S400/2Y	TSSOP56	reel 13" q1 dry pack	2000	T <sub>amb</sub> = -40 °C to +85 °C
PCF8576DU/DA/2	PCF8576DU/DA/2,026	wire bond die	2" waffle carriers	8640	T <sub>amb</sub> = -40 °C to +85 °C
PCF8576DU/2DA/2	PCF8576DU/2DA/2,02	bare die	2" waffle carriers	8640	T <sub>amb</sub> = -40 °C to +85 °C

[1] See 202107021DN - drop in replacement is PCF8576DT/2,518 - this is documented in PCN202102010F01.

[2] See 202107021DN - drop in replacement is PCF8576DT/S400/2Y - this is documented in PCN202102010F01.

### 4 Block diagram

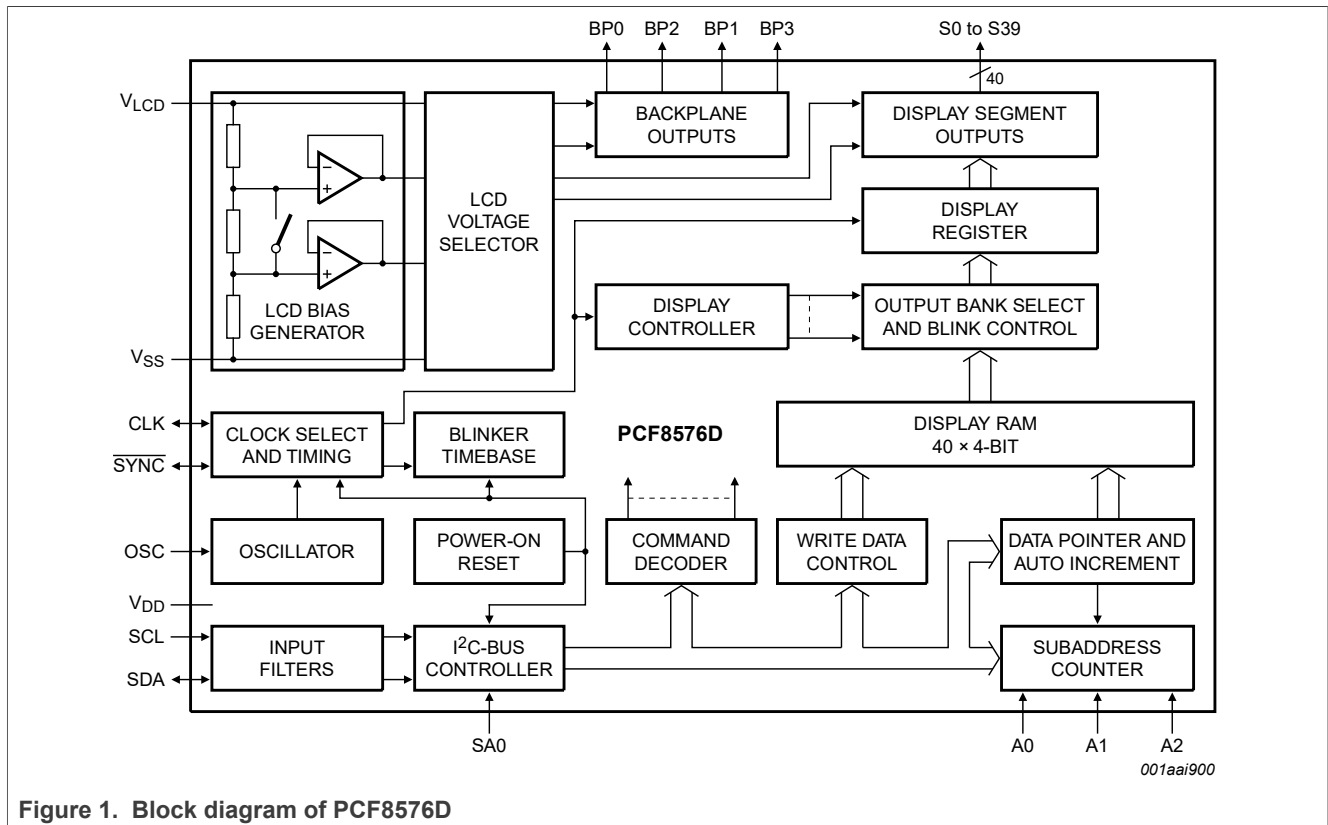
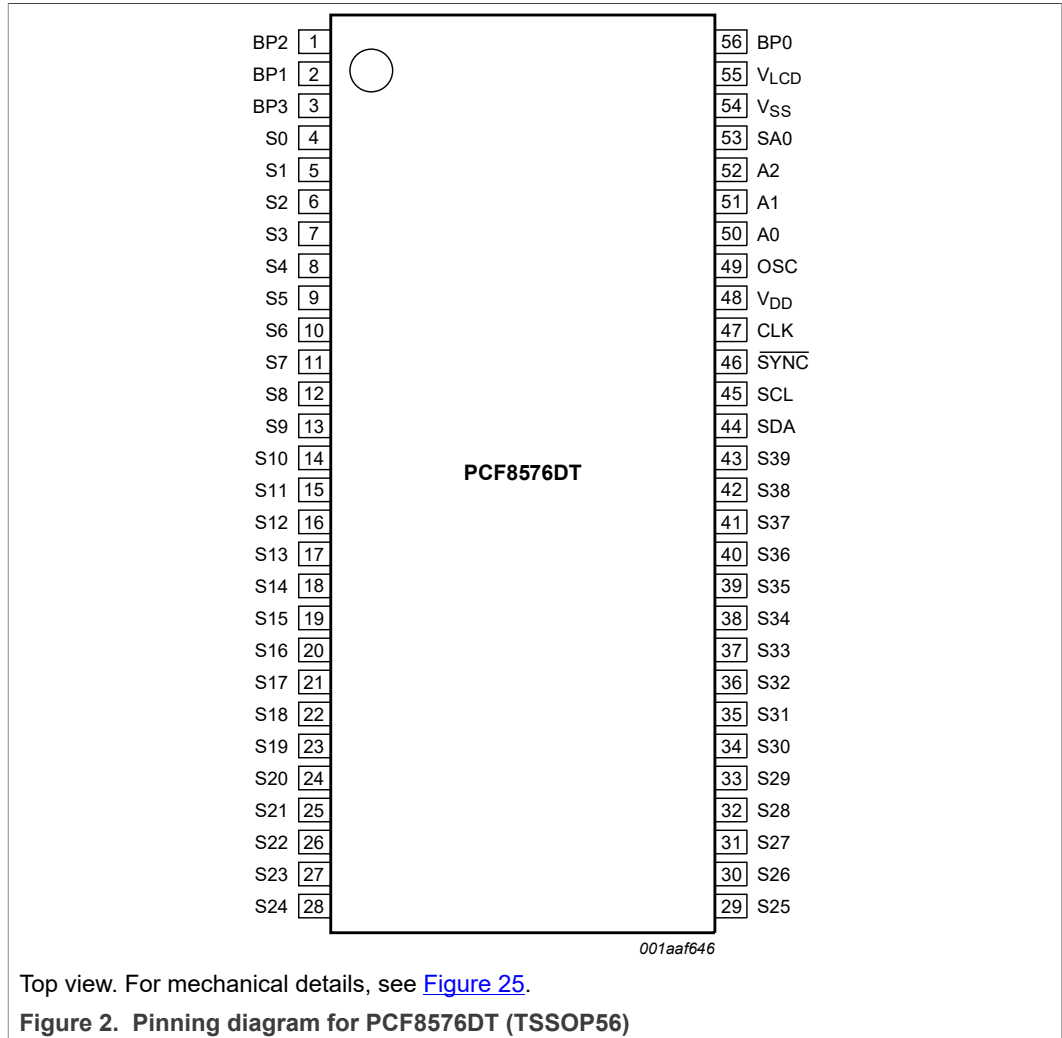
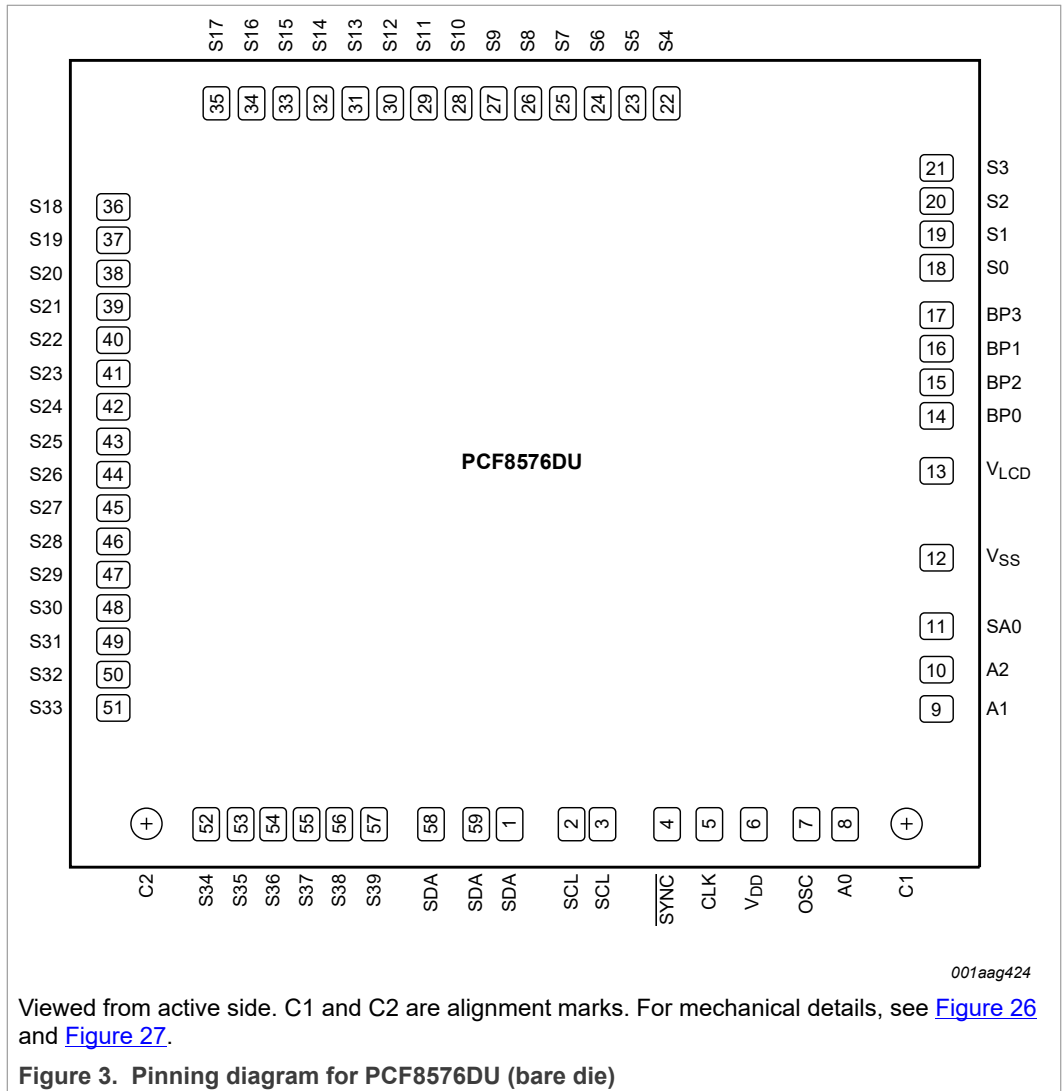

Figure 1. Block diagram of PCF8576D

## 5 Pinning information

### 5.1 Pinning





## 5.2 Pin description

**Table 3. Pin description**

*Input or input/output pins must always be at a defined level ( $V_{SS}$  or  $V_{DD}$ ) unless otherwise specified.*

Symbol	Pin		Description
	PCF8576DT	PCF8576DU	
SDA	44	1, 58, 59	I <sup>2</sup> C-bus serial data input and output
SCL	45	2, 3	I <sup>2</sup> C-bus serial clock input
CLK	47	5	external clock input or output
V <sub>DD</sub>	48	6	supply voltage
SYNC	46	4	cascade synchronization input or output; if not used it must be left open
OSC	49	7	internal oscillator enable input

**Table 3. Pin description...continued**

Input or input/output pins must always be at a defined level ( $V_{SS}$  or  $V_{DD}$ ) unless otherwise specified.

Symbol	Pin		Description
	PCF8576DT	PCF8576DU	
A0 to A2	50 to 52	8 to 10	subaddress inputs
SA0	53	11	I <sup>2</sup> C-bus address input; bit 0
V <sub>SS</sub>	54	12 <sup>[1]</sup>	ground supply voltage
V <sub>LCD</sub>	55	13	LCD supply voltage
BP0, BP2, BP1, BP3	56, 1, 2, 3	14 to 17	LCD backplane outputs
S0 to S39	4 to 43	18 to 57	LCD segment outputs
n.c.	-	-	not connected

[1] The substrate (rear side of the die) is connected to  $V_{SS}$  and should be electrically isolated .

## 6 Functional description

The PCF8576D is a versatile peripheral device designed to interface between any microcontroller to a wide variety of LCD segment or dot matrix displays (see [Figure 4](#)). It can directly drive any static or multiplexed LCD containing up to four backplanes and up to 40 segments.

The possible display configurations of the PCF8576D depend on the number of active backplane outputs required. A selection of display configurations is shown in [Table 4](#). All of these configurations can be implemented in the typical system shown in [Figure 5](#).

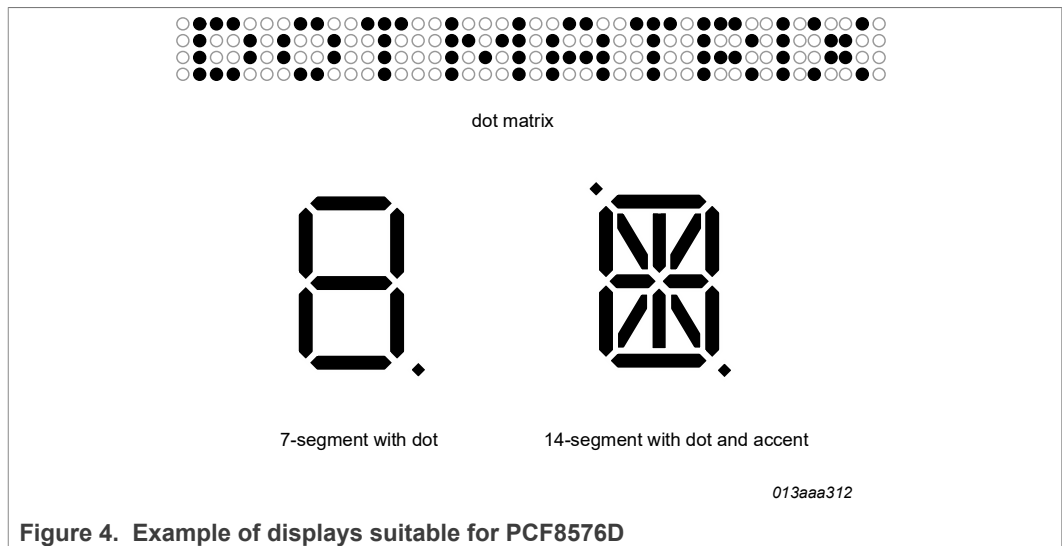
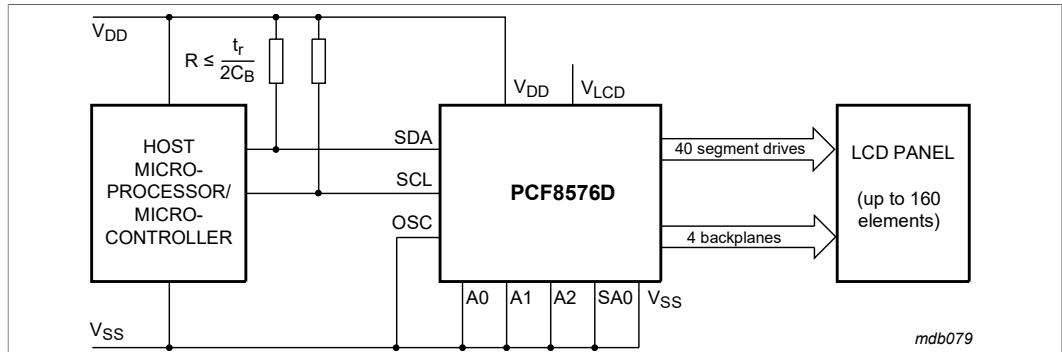

**Figure 4. Example of displays suitable for PCF8576D**

Table 4. Selection of possible display configurations

Number of Backplanes	Icons	Digits/Characters		Dot matrix: segments/elements
		7-segment <sup>[1]</sup>	14-segment <sup>[2]</sup>	
4	160	20	10	160 (4 × 40)
3	120	15	7	120 (3 × 40)
2	80	10	5	80 (2 × 40)
1	40	5	2	40 (1 × 40)

[1] 7 segment display has 8 segments/elements including the decimal point.  
 [2] 14 segment display has 16 segments/elements including decimal point and accent dot.



The resistance of the power lines must be kept to a minimum. For chip-on-glass applications, due to the Indium Tin Oxide (ITO) track resistance, each supply line must be routed separately between the chip and the connector.

Figure 5. Typical system configuration

The host microcontroller maintains the 2-line I<sup>2</sup>C-bus communication channel with the PCF8576D. The internal oscillator is enabled by connecting pin OSC to pin V<sub>SS</sub>. The appropriate biasing voltages for the multiplexed LCD waveforms are generated internally. The only other connections required to complete the system are to the power supplies (V<sub>DD</sub>, V<sub>SS</sub>, and V<sub>LCD</sub>) and the LCD panel chosen for the application.

### 6.1 Power-On Reset (POR)

At power-on the PCF8576D resets to the following starting conditions:

- All backplane and segment outputs are set to V<sub>LCD</sub>
- The selected drive mode is: 1:4 multiplex with 1/3 bias
- Blinking is switched off
- Input and output bank selectors are reset
- The I<sup>2</sup>C-bus interface is initialized
- The data pointer and the subaddress counter are cleared (set to logic 0)
- The display is disabled (bit E = 0, see Table 11)

**Remark:** Do not transfer data on the I<sup>2</sup>C-bus for at least 1 ms after a power-on to allow the reset action to complete.

### 6.2 LCD bias generator

Fractional LCD biasing voltages are obtained from an internal voltage divider of three impedances connected between pins  $V_{LCD}$  and  $V_{SS}$ . The center impedance is bypassed by switch if the  $\frac{1}{2}$  bias voltage level for the 1:2 multiplex drive mode configuration is selected. The LCD voltage can be temperature compensated externally using the supply to pin  $V_{LCD}$ .

### 6.3 LCD voltage selector

The LCD voltage selector coordinates the multiplexing of the LCD in accordance with the selected LCD drive configuration. The operation of the voltage selector is controlled by the mode-set command from the command decoder. The biasing configurations that apply to the preferred modes of operation, together with the biasing characteristics as functions of  $V_{LCD}$  and the resulting discrimination ratios (D) are given in [Table 5](#).

Discrimination is a term which is defined as the ratio of the on and off RMS voltage across a segment. It can be thought of as a measurement of contrast.

Table 5. Biasing characteristics

LCD drive mode	Number of:		LCD bias configuration	$\frac{V_{off(RMS)}}{V_{LCD}}$	$\frac{V_{on(RMS)}}{V_{LCD}}$	$D = \frac{V_{on(RMS)}}{V_{off(RMS)}}$
	Backplanes	Levels				
static	1	2	static	0	1	$\infty$
1:2 multiplex	2	3	$\frac{1}{2}$	0.354	0.791	2.236
1:2 multiplex	2	4	$\frac{1}{3}$	0.333	0.745	2.236
1:3 multiplex	3	4	$\frac{1}{3}$	0.333	0.638	1.915
1:4 multiplex	4	4	$\frac{1}{3}$	0.333	0.577	1.732

A practical value for  $V_{LCD}$  is determined by equating  $V_{off(RMS)}$  with a defined LCD threshold voltage ( $V_{th(off)}$ ), typically when the LCD exhibits approximately 10 % contrast. In the static drive mode a suitable choice is  $V_{LCD} > 3V_{th(off)}$ .

Multiplex drive modes of 1:3 and 1:4 with  $\frac{1}{2}$  bias are possible but the discrimination and hence the contrast ratios are smaller.

Bias is calculated by  $\frac{1}{1+a}$ , where the values for a are

$a = 1$  for  $\frac{1}{2}$  bias

$a = 2$  for  $\frac{1}{3}$  bias

The RMS on-state voltage ( $V_{on(RMS)}$ ) for the LCD is calculated with [Equation 1](#):

$$V_{on(RMS)} = \frac{V_{LCD}}{n} \sqrt{\frac{a^2 + 2a + n}{(1+a)^2}} \quad (1)$$

where the values for n are

$n = 1$  for static drive mode

$n = 2$  for 1:2 multiplex drive mode

$n = 3$  for 1:3 multiplex drive mode

$n = 4$  for 1:4 multiplex drive mode

The RMS off-state voltage ( $V_{off(RMS)}$ ) for the LCD is calculated with [Equation 2](#):

$$V_{off(RMS)} = \frac{V_{LCD}}{\sqrt{n \times (1+a)^2}} \sqrt{a^2 - 2a + n} \quad (2)$$

Discrimination is the ratio of  $V_{on(RMS)}$  to  $V_{off(RMS)}$  and is determined from [Equation 3](#):

$$D = \frac{V_{on(RMS)}}{V_{off(RMS)}} = \sqrt{\frac{a^2 + 2a + n}{a^2 - 2a + n}} \quad (3)$$

Using [Equation 3](#), the discrimination for an LCD drive mode of 1:3 multiplex with  $\frac{1}{2}$  bias is  $\sqrt{3} = 1.732$  and the discrimination for an LCD drive mode of 1:4 multiplex with  $\frac{1}{2}$  bias is  $\frac{\sqrt{21}}{3} = 1.528$ .

The advantage of these LCD drive modes is a reduction of the LCD full scale voltage  $V_{LCD}$  as follows:

- 1:3 multiplex ( $\frac{1}{2}$  bias):  $V_{LCD} = \sqrt{6} \times V_{off(RMS)} = 2.449V_{off(RMS)}$
- 1:4 multiplex ( $\frac{1}{2}$  bias):  $V_{LCD} = \left[ \frac{4 \times \sqrt{3}}{3} \right] = 2.309V_{off(RMS)}$

These compare with  $V_{LCD} = 3V_{off(RMS)}$  when  $\frac{1}{3}$  bias is used.

It should be noted that  $V_{LCD}$  is sometimes referred as the LCD operating voltage.

### 6.3.1 Electro-optical performance

Suitable values for  $V_{on(RMS)}$  and  $V_{off(RMS)}$  are dependent on the LCD liquid used. The RMS voltage, at which a pixel will be switched on or off, determine the transmissibility of the pixel.

For any given liquid, there are two threshold values defined. One point is at 10 % relative transmission (at  $V_{th(off)}$ ) and the other at 90 % relative transmission (at  $V_{th(on)}$ ), see [Figure 6](#). For a good contrast performance, the following rules should be followed:

$$V_{on(RMS)} \geq V_{th(on)} \quad (4)$$

$$V_{off(RMS)} \leq V_{th(off)} \quad (5)$$

$V_{on(RMS)}$  and  $V_{off(RMS)}$  are properties of the display driver and are affected by the selection of a, n (see [Equation 1](#) to [Equation 3](#)) and the  $V_{LCD}$  voltage.

$V_{th(off)}$  and  $V_{th(on)}$  are properties of the LCD liquid and can be provided by the module manufacturer.  $V_{th(off)}$  is sometimes just named  $V_{th}$ .  $V_{th(on)}$  is sometimes named saturation voltage  $V_{sat}$ .

It is important to match the module properties to those of the driver in order to achieve optimum performance.

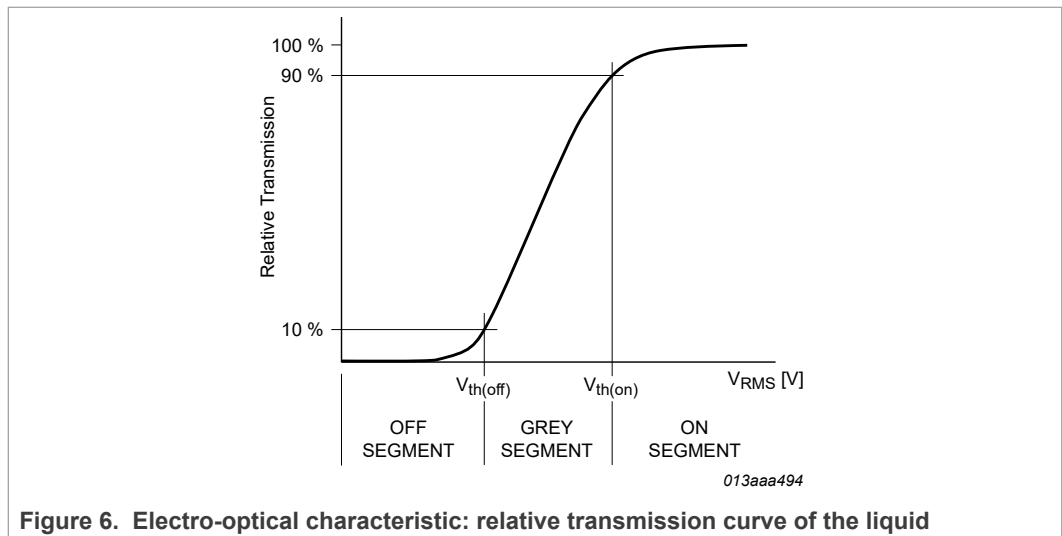

## 6.4 LCD drive mode waveforms

### 6.4.1 Static drive mode

The static LCD drive mode is used when a single backplane is provided in the LCD. The backplane (BPn) and segment drive ( $S_n$ ) waveforms for this mode are shown in [Figure 7](#).

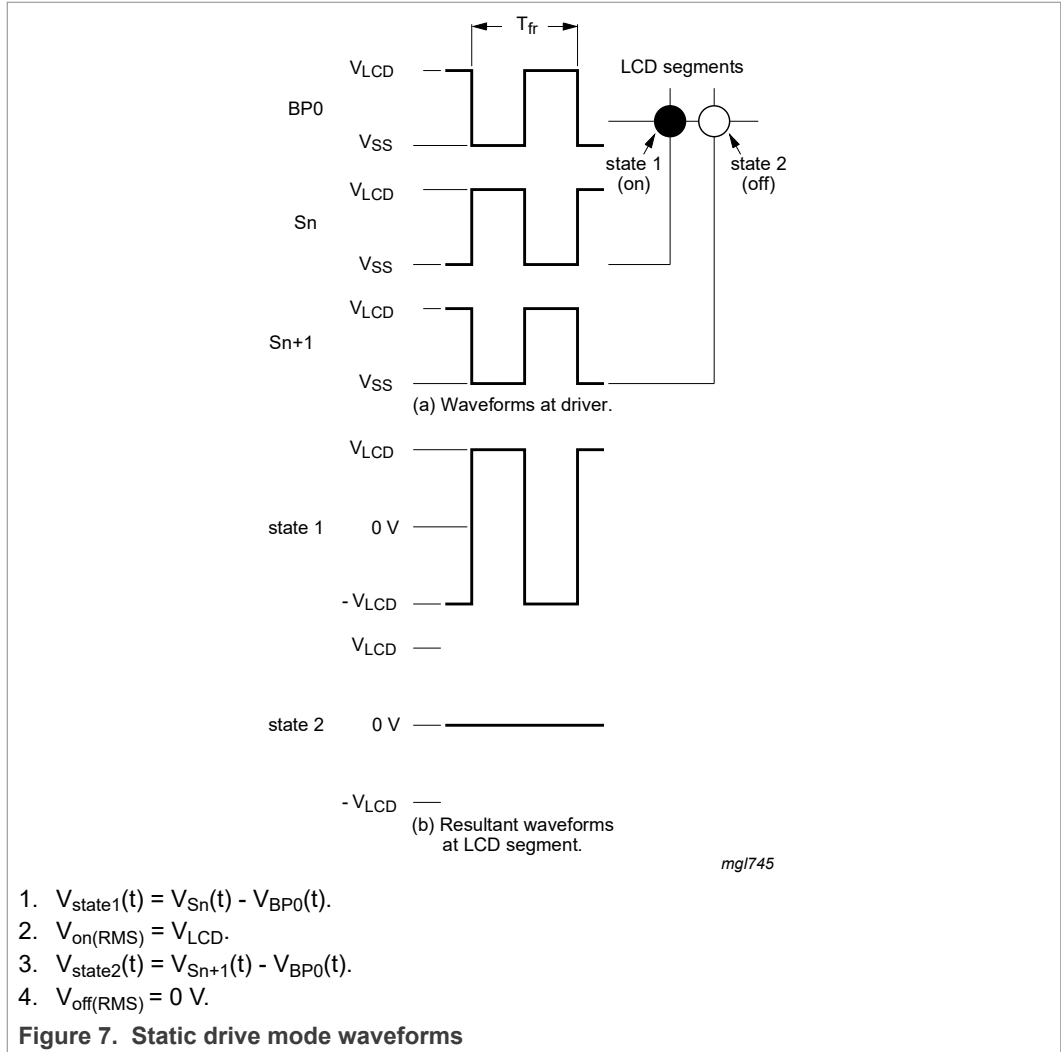

**6.4.2 1:2 Multiplex drive mode**

The 1:2 multiplex drive mode is used when two backplanes are provided in the LCD. This mode allows fractional LCD bias voltages of  $\frac{1}{2}$  bias or  $\frac{1}{3}$  bias as shown in [Figure 8](#) and [Figure 9](#).

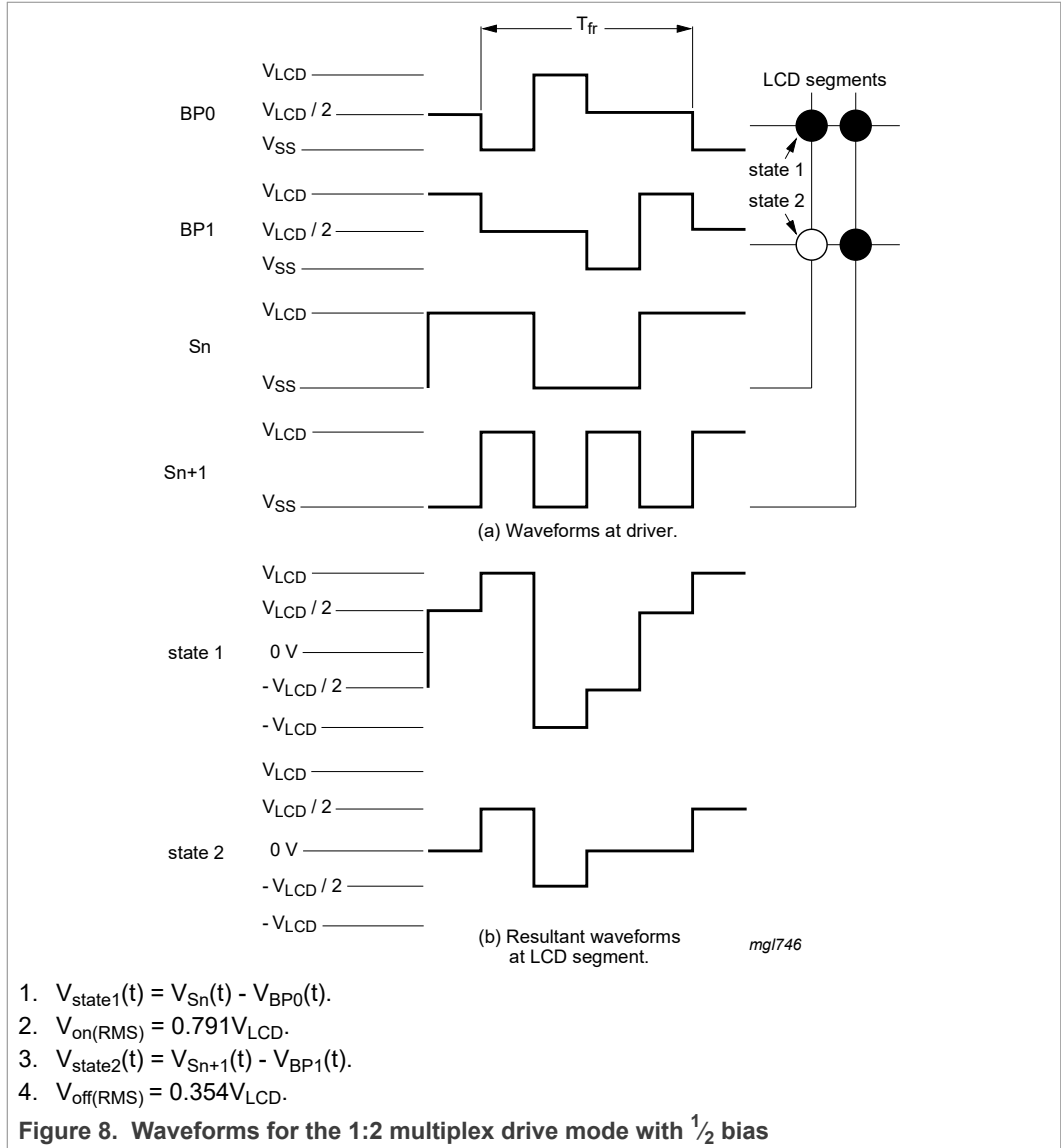

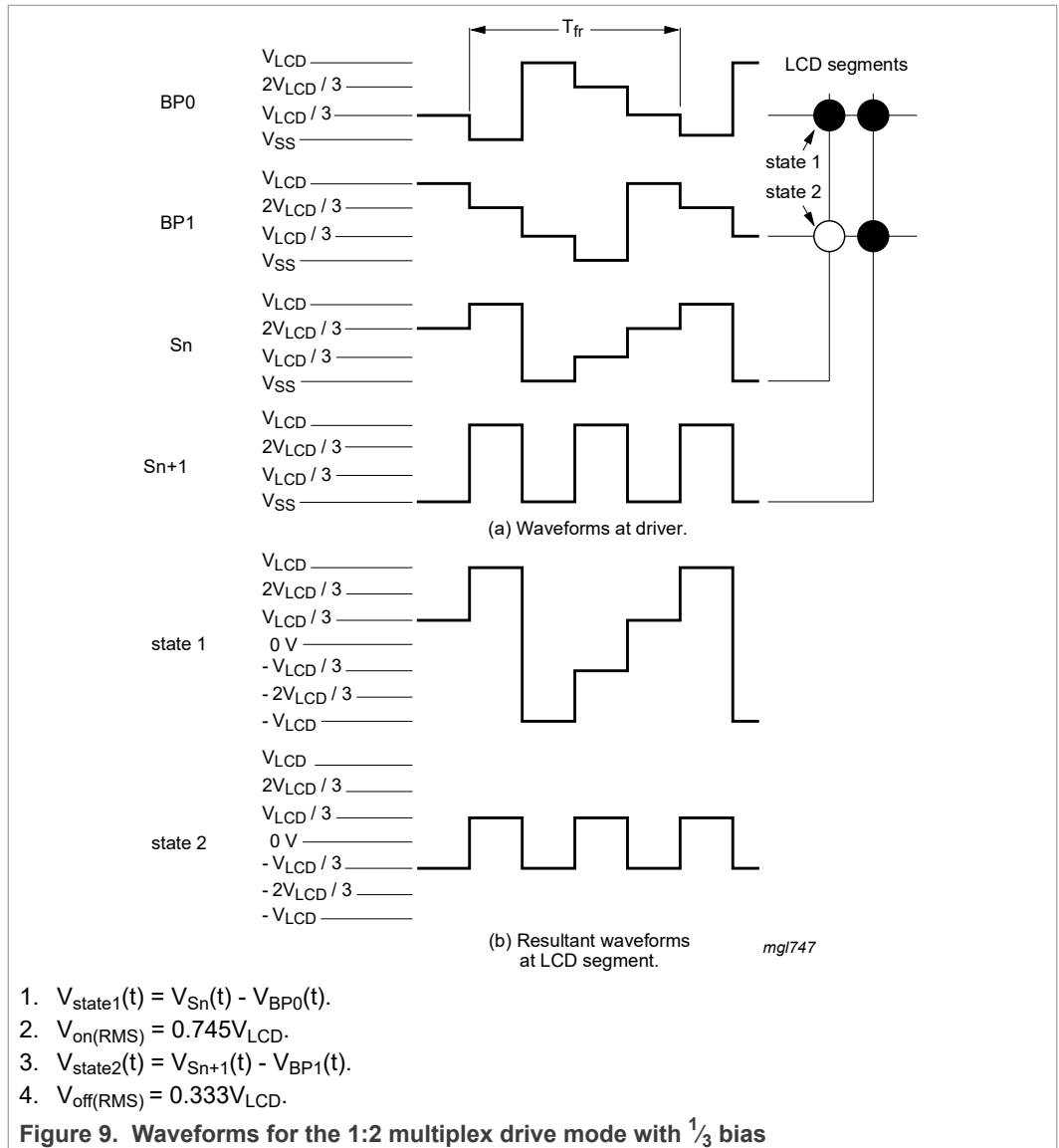

**6.4.3 1:3 Multiplex drive mode**

When three backplanes are provided in the LCD, the 1:3 multiplex drive mode applies (see [Figure 10](#)).

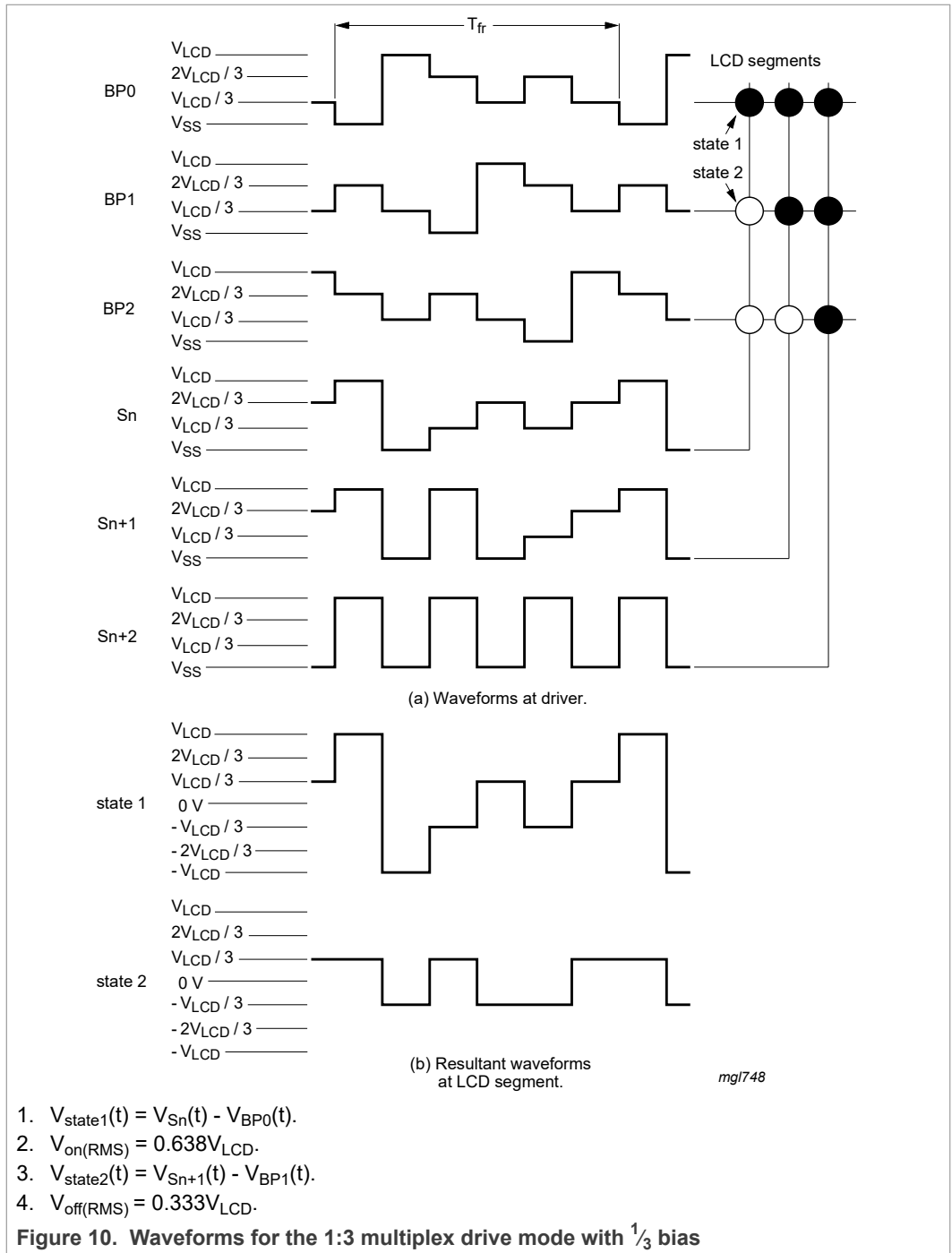

6.4.4 1:4 Multiplex drive mode

When four backplanes are provided in the LCD, the 1:4 multiplex drive mode applies (see [Figure 11](#)).

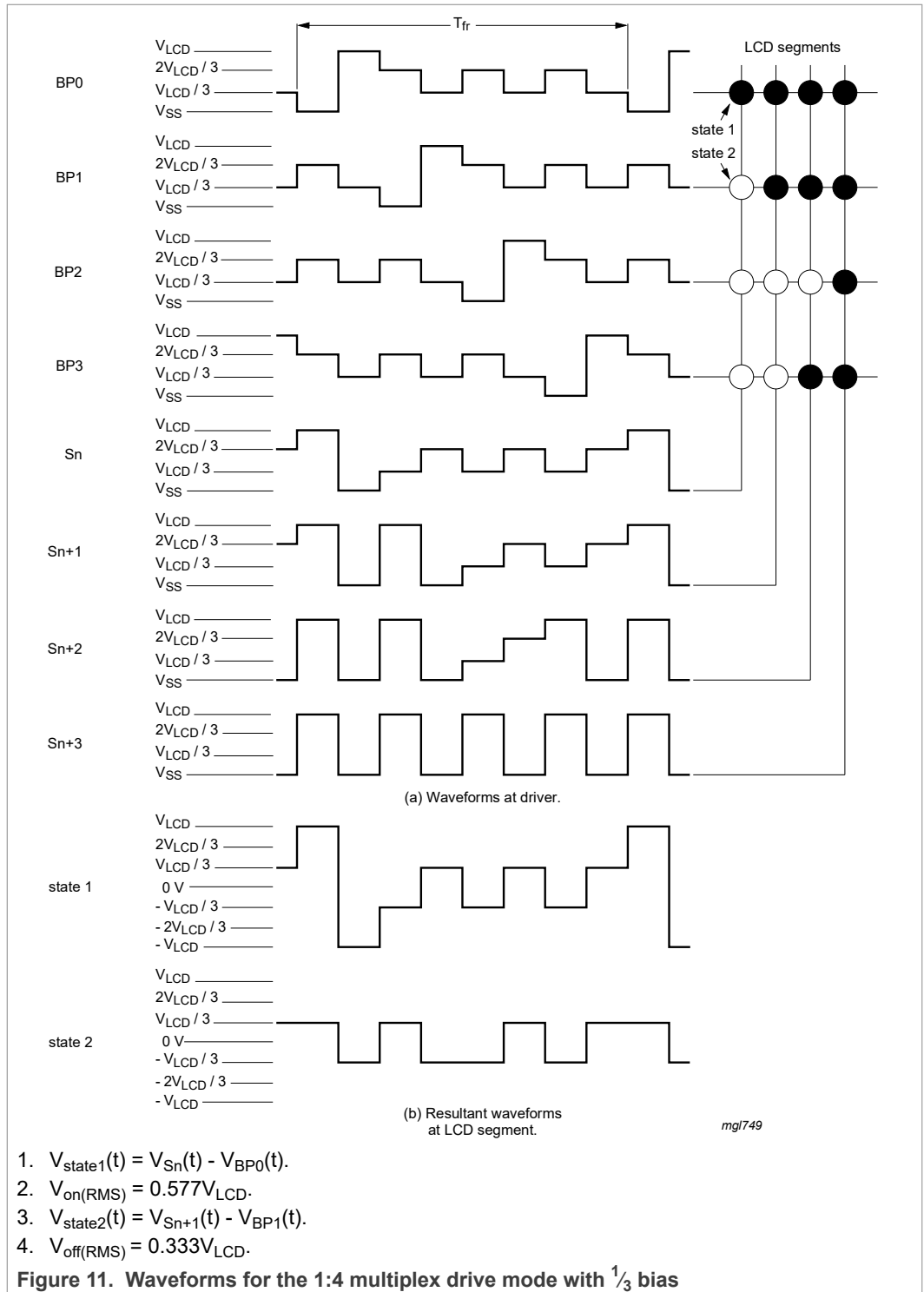

### 6.5 Oscillator

### 6.5.1 Internal clock

The internal logic of the PCF8576D and its LCD drive signals are timed either by its internal oscillator or by an external clock. The internal oscillator is enabled by connecting pin OSC to pin V<sub>SS</sub>. If the internal oscillator is used, the output from pin CLK can be used as the clock signal for several PCF8576Ds in the system that are connected in cascade.

### 6.5.2 External clock

Pin CLK is enabled as an external clock input by connecting pin OSC to V<sub>DD</sub>. The LCD frame signal frequency is determined by the clock frequency (f<sub>clk</sub>).

**Remark:** A clock signal must always be supplied to the device; removing the clock may freeze the LCD in a DC state, which is not suitable for the liquid crystal.

## 6.6 Timing

The PCF8576D timing controls the internal data flow of the device. This includes the transfer of display data from the display RAM to the display segment outputs. In cascaded applications, the correct timing relationship between each PCF8576D in the system is maintained by the synchronization signal at pin  $\overline{\text{SYNC}}$ . The timing also generates the LCD frame signal whose frequency is derived from the clock frequency. The frame signal frequency is a fixed division of the clock frequency from either the internal or an external clock: .

$$f_{fr} = \frac{f_{clk}}{24}$$

### 6.7 Display register

The display latch holds the display data while the corresponding multiplex signals are generated.

### 6.8 Segment outputs

The LCD drive section includes 40 segment outputs S0 to S39 which should be connected directly to the LCD. The segment output signals are generated in accordance with the multiplexed backplane signals and with data residing in the display latch. When less than 40 segment outputs are required, the unused segment outputs should be left open-circuit.

### 6.9 Backplane outputs

The LCD drive section includes four backplane outputs BP0 to BP3 which must be connected directly to the LCD. The backplane output signals are generated in accordance with the selected LCD drive mode. If less than four backplane outputs are required, the unused outputs can be left open-circuit.

- In 1:3 multiplex drive mode, BP3 carries the same signal as BP1, therefore these two adjacent outputs can be tied together to give enhanced drive capabilities.
- In 1:2 multiplex drive mode, BP0 and BP2, respectively, BP1 and BP3 all carry the same signals and may also be paired to increase the drive capabilities.
- In static drive mode the same signal is carried by all four backplane outputs and they can be connected in parallel for very high drive requirements.

### 6.10 Display RAM

The display RAM is a static 40 × 4-bit RAM which stores LCD data.

There is a one-to-one correspondence between

- the bits in the RAM bitmap and the LCD segments/elements
- the RAM columns and the segment outputs
- the RAM rows and the backplane outputs.

A logic 1 in the RAM bitmap indicates the on-state of the corresponding LCD element; similarly, a logic 0 indicates the off-state.

The display RAM bit map, [Figure 12](#), shows the rows 0 to 3 which correspond with the backplane outputs BP0 to BP3, and the columns 0 to 39 which correspond with the segment outputs S0 to S39. In multiplexed LCD applications the segment data of the first, second, third and fourth row of the display RAM are time-multiplexed with BP0, BP1, BP2, and BP3 respectively.

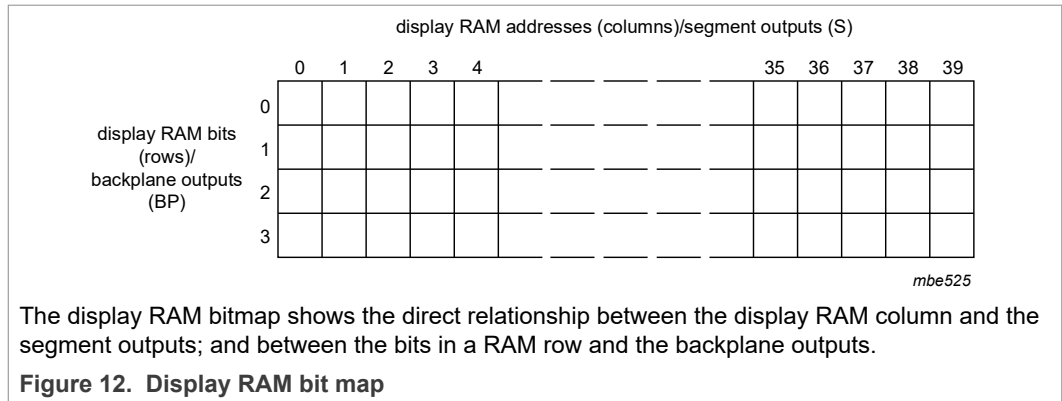

When display data is transmitted to the PCF8576D, the received display bytes are stored in the display RAM in accordance with the selected LCD drive mode. The data is stored as it arrives and depending on the current multiplex drive mode the bits are stored singularly, in pairs, triples, or quadruples. To illustrate the filling order, an example of a 7-segment display showing all drive modes is given in [Figure 13](#); the RAM filling organization depicted applies equally to other LCD types.

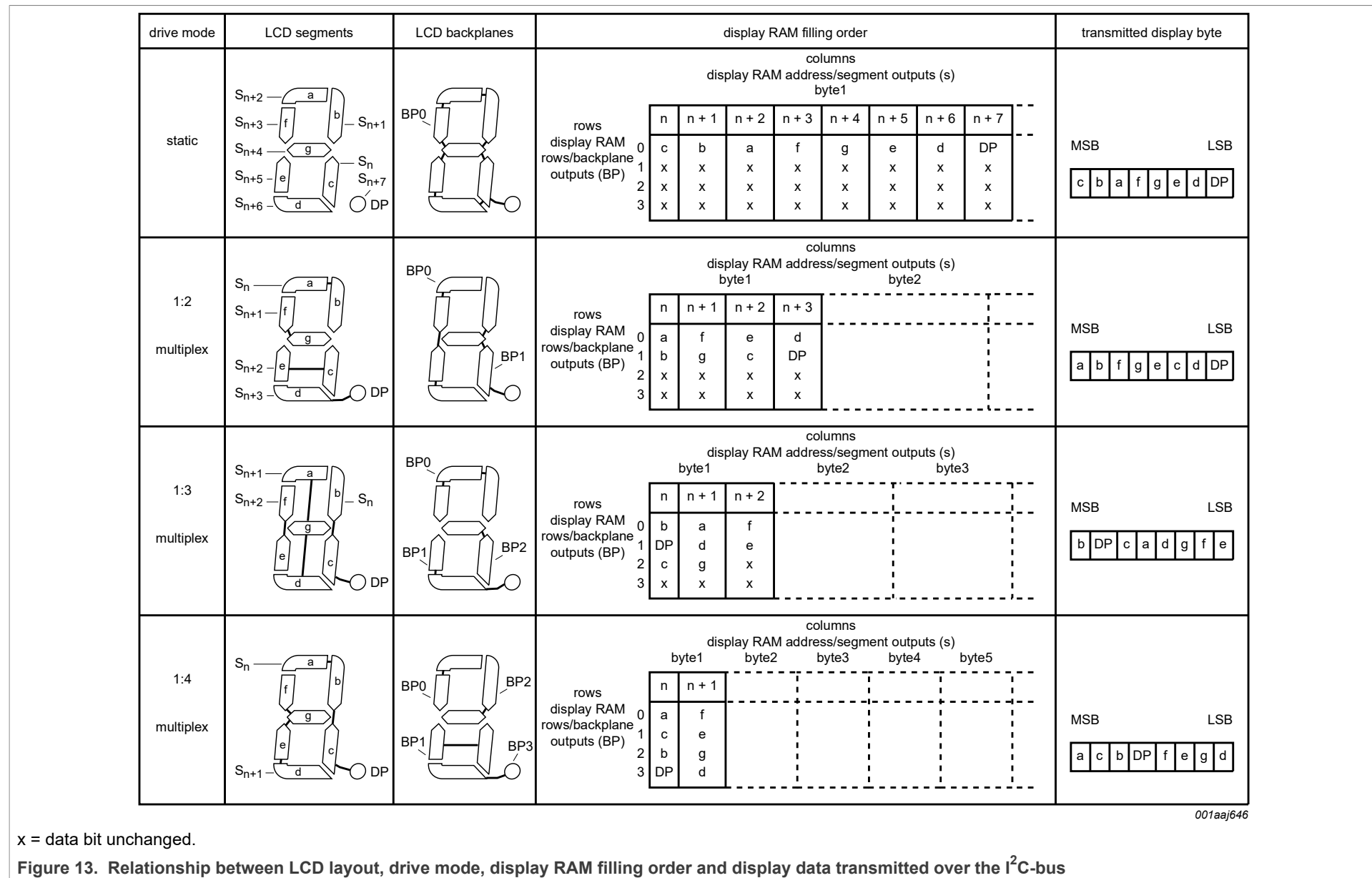

001aa|646

x = data bit unchanged.

Figure 13. Relationship between LCD layout, drive mode, display RAM filling order and display data transmitted over the I<sup>2</sup>C-bus

The following applies to [Figure 13](#):

- In static drive mode the eight transmitted data bits are placed into row 0 as one byte.
- In 1:2 multiplex drive mode the eight transmitted data bits are placed in pairs into row 0 and 1 as four successive 2-bit RAM words.
- In 1:3 multiplex drive mode the eight bits are placed in triples into row 0, 1, and 2 as three successive 3-bit RAM words, with bit 3 of the third address left unchanged. It is not recommended to use this bit in a display because of the difficult addressing. This last bit may, if necessary, be controlled by an additional transfer to this address, but care should be taken to avoid overwriting adjacent data because always full bytes are transmitted (see [Section 6.10.3](#)).
- In 1:4 multiplex drive mode, the eight transmitted data bits are placed in quadruples into row 0, 1, 2, and 3 as two successive 4-bit RAM words.

### 6.10.1 Data pointer

The addressing mechanism for the display RAM is realized using the data pointer. This allows the loading of an individual display data byte, or a series of display data bytes, into any location of the display RAM. The sequence commences with the initialization of the data pointer by the load-data-pointer command (see [Table 12](#)). Following this command, an arriving data byte is stored at the display RAM address indicated by the data pointer. The filling order is shown in [Figure 13](#). After each byte is stored, the content of the data pointer is automatically incremented by a value dependent on the selected LCD drive mode:

- In static drive mode by eight.
- In 1:2 multiplex drive mode by four.
- In 1:3 multiplex drive mode by three.
- In 1:4 multiplex drive mode by two.

If an I<sup>2</sup>C-bus data access terminates early then the state of the data pointer is unknown. Consequently, the data pointer must be rewritten prior to further RAM accesses.

### 6.10.2 Subaddress counter

The storage of display data is determined by the contents of the subaddress counter. Storage is allowed only when the content of the subaddress counter match with the hardware subaddress applied to A0, A1, and A2. The subaddress counter value is defined by the device-select command (see [Table 13](#)). If the content of the subaddress counter and the hardware subaddress do not match then data storage is inhibited but the data pointer is incremented as if data storage had taken place. The subaddress counter is also incremented when the data pointer overflows.

The storage arrangements described lead to extremely efficient data loading in cascaded applications. When a series of display bytes are sent to the display RAM, automatic wrap-over to the next PCF8576D occurs when the last RAM address is exceeded. Subaddressing across device boundaries is successful even if the change to the next device in the cascade occurs within a transmitted character.

The hardware subaddress must not be changed while the device is being accessed on the I<sup>2</sup>C-bus interface.

6.10.3 RAM writing in 1:3 multiplex drive mode

In 1:3 multiplex drive mode, the RAM is written as shown in [Table 6](#) (see [Figure 13](#) as well).

Table 6. Standard RAM filling in 1:3 multiplex drive mode

Assumption: BP2/S2, BP2/S5, BP2/S8 etc. are not connected to any segments/elements on the display.

Display RAM bits (rows)/ backplane outputs (BPn)	Display RAM addresses (columns)/segment outputs (Sn)										
	0	1	2	3	4	5	6	7	8	9	:
0	a7	a4	a1	b7	b4	b1	c7	c4	c1	d7	:
1	a6	a3	a0	b6	b3	b0	c6	c3	c0	d6	:
2	a5	a2	-	b5	b2	-	c5	c2	-	d5	:
3	-	-	-	-	-	-	-	-	-	-	:

If the bit at position BP2/S2 would be written by a second byte transmitted, then the mapping of the segment bits would change as illustrated in [Table 7](#).

Table 7. Entire RAM filling by rewriting in 1:3 multiplex drive mode

Assumption: BP2/S2, BP2/S5, BP2/S8 etc. are connected to segments/elements on the display.

Display RAM bits (rows)/ backplane outputs (BPn)	Display RAM addresses (columns)/segment outputs (Sn)										
	0	1	2	3	4	5	6	7	8	9	:
0	a7	a4	a1/b7	b4	b1/c7	c4	c1/d7	d4	d1/e7	e4	:
1	a6	a3	a0/b6	b3	b0/c6	c3	c0/d6	d3	d0/e6	e3	:
2	a5	a2	b5	b2	c5	c2	d5	d2	e5	e2	:
3	-	-	-	-	-	-	-	-	-	-	:

In the case described in [Table 7](#) the RAM has to be written entirely and BP2/S2, BP2/S5, BP2/S8 etc. have to be connected to segments/elements on the display. This can be achieved by a combination of writing and rewriting the RAM like follows:

- In the first write to the RAM, bits a7 to a0 are written.
- In the second write, bits b7 to b0 are written, overwriting bits a1 and a0 with bits b7 and b6.
- In the third write, bits c7 to c0 are written, overwriting bits b1 and b0 with bits c7 and c6.

Depending on the method of writing to the RAM (standard or entire filling by rewriting), some segments/elements remain unused or can be used, but it has to be considered in the module layout process as well as in the driver software design.

6.10.4 Writing over the RAM address boundary

In all multiplex drive modes, depending on the setting of the data pointer, it is possible to fill the RAM over the RAM address boundary. If the PCF8576D is part of a cascade the additional bits fall into the next device that also generates the acknowledge signal. If the PCF8576D is a single device or the last device in a cascade the additional bits will be discarded and no acknowledge signal will be generated.

**6.10.5 Output bank selector**

The output bank selector (see [Table 14](#)) selects one of the four rows per display RAM address for transfer to the display register. The actual row selected depends on the selected LCD drive mode in operation and on the instant in the multiplex sequence.

- In 1:4 multiplex mode, all RAM addresses of row 0 are selected, these are followed by the contents of row 1, 2, and then 3
- In 1:3 multiplex mode, rows 0, 1, and 2 are selected sequentially
- In 1:2 multiplex mode, rows 0 and 1 are selected
- In static mode, row 0 is selected

The PCF8576D includes a RAM bank switching feature in the static and 1:2 multiplex drive modes. In the static drive mode, the bank-select command may request the contents of row 2 to be selected for display instead of the contents of row 0. In the 1:2 multiplex mode, the contents of rows 2 and 3 may be selected instead of rows 0 and 1. This gives the provision for preparing display information in an alternative bank and to be able to switch to it once it is assembled.

**6.10.6 Input bank selector**

The input bank selector loads display data into the display RAM in accordance with the selected LCD drive configuration. Display data can be loaded in row 2 in static drive mode or in rows 2 and 3 in 1:2 multiplex drive mode by using the bank-select command (see [Table 14](#)). The input bank selector functions independently to the output bank selector.

**6.11 Blinking**

The display blinking capabilities of the PCF8576D are very versatile. The whole display can blink at frequencies selected by the blink-select command (see [Table 15](#)). The blink frequencies are derived from the clock frequency. The ratio between the clock and blink frequencies depends on the blink mode selected (see [Table 15](#)).

An additional feature is for an arbitrary selection of LCD segments/elements to blink. This applies to the static and 1:2 multiplex drive modes and can be implemented without any communication overheads. By means of the output bank selector, the displayed RAM banks are exchanged with alternate RAM banks at the blink frequency. This mode can also be specified by the blink-select command.

In the 1:3 and 1:4 multiplex modes, where no alternative RAM bank is available, groups of LCD segments/elements can blink by selectively changing the display RAM data at fixed time intervals.

The entire display can blink at a frequency other than the nominal blink frequency. This can be effectively performed by resetting and setting the display enable bit E at the required rate using the mode-set command (see [Table 11](#)).

**Table 8. Blinking frequencies**

Blink mode	Normal operating mode ratio	Nominal blink frequency <sup>[1]</sup>
off	-	blinking off
1	$\frac{f_{clk}}{768}$	2 Hz
2	$\frac{f_{clk}}{1536}$	1 Hz

Table 8. Blinking frequencies...continued

Blink mode	Normal operating mode ratio	Nominal blink frequency <sup>[1]</sup>
3	$\frac{f_{clk}}{3072}$	0.5 Hz

[1] Blink modes 1, 2 and 3 and the nominal blink frequencies 0.5 Hz, 1 Hz and 2 Hz correspond to an oscillator frequency ( $f_{clk}$ ) of 1536 Hz (see [Section 12](#)).

## 6.12 Command decoder

The command decoder identifies command bytes that arrive on the I<sup>2</sup>C-bus. The commands available to the PCF8576D are defined in [Table 9](#).

Table 9. Definition of PCF8576D commands

Command	Operation code								Reference	
	7	6	5	4	3	2	1	0		
mode-set	C	1	0	- <sup>[1]</sup>	E	B	M[1:0]		<a href="#">Table 11</a>	
load-data-pointer	C	0	P[5:0]							<a href="#">Table 12</a>
device-select	C	1	1	0	0	A[2:0]			<a href="#">Table 13</a>	
bank-select	C	1	1	1	1	0	I	O	<a href="#">Table 14</a>	
blink-select	C	1	1	1	0	AB	BF[1:0]		<a href="#">Table 15</a>	

[1] Not used.

All available commands carry a continuation bit C in their most significant bit position as shown in [Figure 19](#). When this bit is set logic 1, it indicates that the next byte of the transfer to arrive will also represent a command. If this bit is set logic 0, it indicates that the command byte is the last in the transfer. Further bytes will be regarded as display data (see [Table 10](#)).

Table 10. C bit description

Bit	Symbol	Value	Description
7	C		<b>continue bit</b>
		0	last control byte in the transfer; next byte will be regarded as display data
		1	control bytes continue; next byte will be a command too

Table 11. Mode-set command bit description

Bit	Symbol	Value	Description
7	C	0, 1	see <a href="#">Table 10</a>
6, 5	-	10	fixed value
4	-	-	unused
3	E		<b>display status</b> <sup>[1]</sup>
		0 <sup>[2]</sup>	disabled (blank) <sup>[3]</sup>
		1	enabled
2	B		<b>LCD bias configuration</b> <sup>[4]</sup>

Table 11. Mode-set command bit description...continued

Bit	Symbol	Value	Description
		0 <sup>[2]</sup>	$\frac{1}{3}$ bias
		1	$\frac{1}{2}$ bias
1 to 0	M[1:0]		<b>LCD drive mode selection</b>
		01	static; BP0
		10	1:2 multiplex; BP0, BP1
		11	1:3 multiplex; BP0, BP1, BP2
		00 <sup>[2]</sup>	1:4 multiplex; BP0, BP1, BP2, BP3

[1] The possibility to disable the display allows implementation of blinking under external control.

[2] Default value.

[3] The display is disabled by setting all backplane and segment outputs to  $V_{LCD}$ .

[4] Not applicable for static drive mode.

Table 12. Load-data-pointer command bit description

See [Section 6.10.1](#).

Bit	Symbol	Value	Description
7	C	0, 1	see <a href="#">Table 10</a>
6	-	0	fixed value
5 to 0	P[5:0]	000000 <sup>[1]</sup> to 100111	6 bit binary value, 0 to 39; transferred to the data pointer to define one of forty display RAM addresses

[1] Default value.

Table 13. Device-select command bit description

See [Section 6.10.2](#).

Bit	Symbol	Value	Description
7	C	0, 1	see <a href="#">Table 10</a>
6 to 3	-	1100	fixed value
2 to 0	A[2:0]	000 <sup>[1]</sup> to 111	3 bit binary value, 0 to 7; transferred to the subaddress counter to define one of eight hardware subaddresses

[1] Default value.

Table 14. Bank-select command bit description

See [Section 6.10.5](#) and [Section 6.10.6](#).

Bit	Symbol	Value	Description	
			Static	1:2 multiplex <sup>[1]</sup>
7	C	0, 1	see <a href="#">Table 10</a>	
6 to 2	-	11110	fixed value	
1	I		<b>input bank selection</b> ; storage of arriving display data	

Table 14. Bank-select command bit description...continued

See [Section 6.10.5](#) and [Section 6.10.6](#).

Bit	Symbol	Value	Description	
			Static	1:2 multiplex <sup>[1]</sup>
		0 <sup>[2]</sup>	RAM row 0	RAM rows 0 and 1
		1	RAM row 2	RAM rows 2 and 3
0	O		<b>output bank selection</b> ; retrieval of LCD display data	
		0 <sup>[2]</sup>	RAM row 0	RAM rows 0 and 1
		1	RAM row 2	RAM rows 2 and 3

[1] The bank-select command has no effect in 1:3 and 1:4 multiplex drive modes.

[2] Default value.

Table 15. Blink-select command bit description

See [Section 6.11](#).

Bit	Symbol	Value	Description
7	C	0, 1	see <a href="#">Table 10</a>
6 to 3	-	1110	fixed value
2	AB		<b>blink mode selection</b>
		0 <sup>[1]</sup>	normal blinking <sup>[2]</sup>
		1	alternate RAM bank blinking <sup>[3]</sup>
1 to 0	BF[1:0]		<b>blink frequency selection</b>
		00 <sup>[1]</sup>	off
		01	1
		10	2
		11	3

[1] Default value.

[2] Normal blinking is assumed when the LCD multiplex drive modes 1:3 or 1:4 are selected.

[3] Alternate RAM bank blinking does not apply in 1:3 and 1:4 multiplex drive modes.

### 6.13 Display controller

The display controller executes the commands identified by the command decoder. It contains the device's status registers and coordinates their effects. The display controller is also responsible for loading display data into the display RAM in the correct filling order.

## 7 Characteristics of the I<sup>2</sup>C-bus

The I<sup>2</sup>C-bus is for bidirectional, two-line communication between different ICs or modules. The two lines are a Serial DATA line (SDA) and a Serial CLOCK line (SCL). Both lines must be connected to a positive supply via a pull-up resistor when connected to the output stages of a device. Data transfer may be initiated only when the bus is not busy.

### 7.1 Bit transfer

One data bit is transferred during each clock pulse. The data on the SDA line must remain stable during the HIGH period of the clock pulse as changes in the data line at this time will be interpreted as a control signal (see [Figure 14](#)).

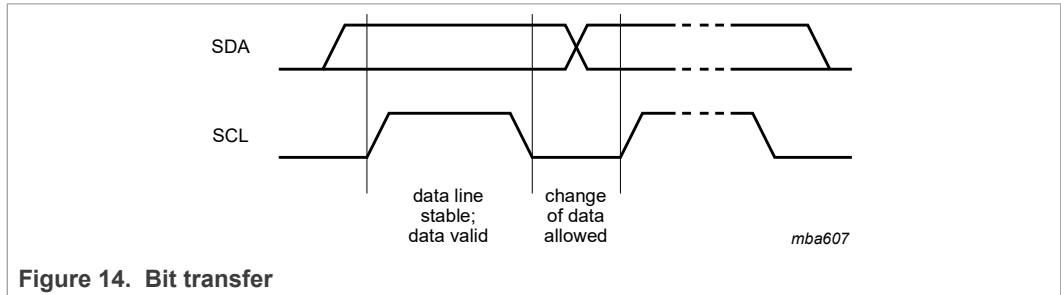

Figure 14. Bit transfer

### 7.2 START and STOP conditions

Both data and clock lines remain HIGH when the bus is not busy.

A HIGH-to-LOW transition of the data line while the clock is HIGH is defined as the START condition - S.

A LOW-to-HIGH transition of the data line while the clock is HIGH is defined as the STOP condition - P.

The START and STOP conditions are illustrated in [Figure 15](#).

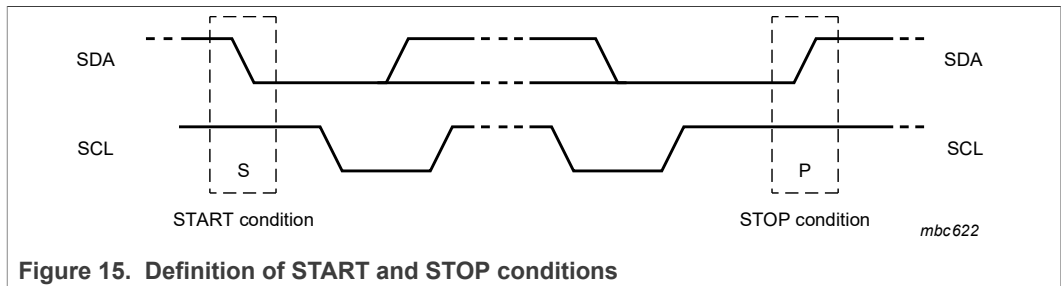

Figure 15. Definition of START and STOP conditions

### 7.3 System configuration

A device generating a message is a transmitter, a device receiving a message is the receiver. The device that controls the message is the controller and the devices which are controlled by the controller are the targets. The system configuration is shown in [Figure 16](#).

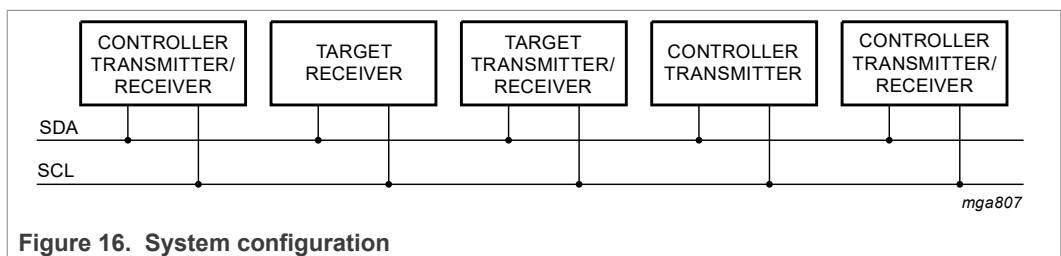

Figure 16. System configuration

### 7.4 Acknowledge

The number of data bytes transferred between the START and STOP conditions from transmitter to receiver is unlimited. Each byte of eight bits is followed by an acknowledge cycle.

- A target receiver, which is addressed, must generate an acknowledge after the reception of each byte.
- A controller receiver must generate an acknowledge after the reception of each byte that has been clocked out of the target transmitter.
- The device that acknowledges must pull-down the SDA line during the acknowledge clock pulse, so that the SDA line is stable LOW during the HIGH period of the acknowledge related clock pulse (set-up and hold times must be taken into consideration).
- A controller receiver must signal an end of data to the transmitter by not generating an acknowledge on the last byte that has been clocked out of the target. In this event, the transmitter must leave the data line HIGH to enable the controller to generate a STOP condition.

Acknowledgement on the I<sup>2</sup>C-bus is illustrated in [Figure 17](#).

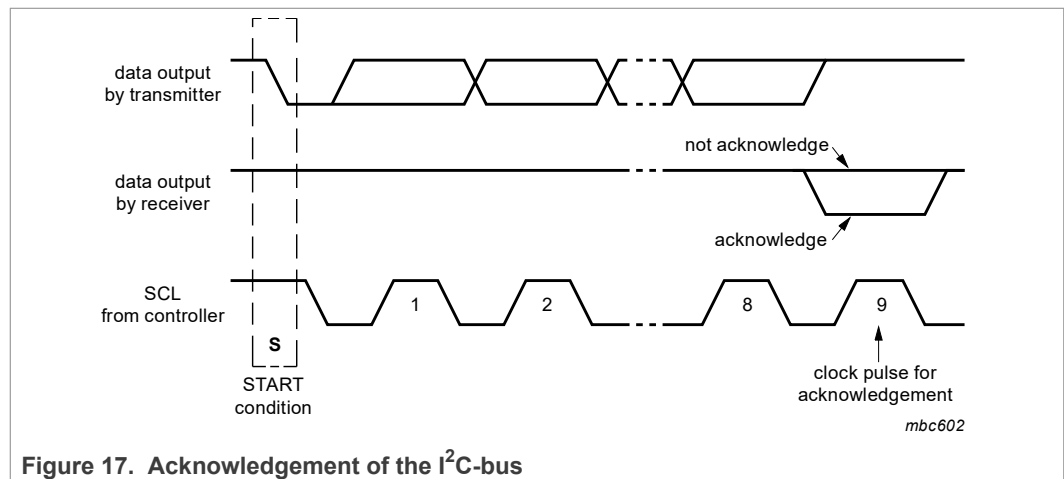

Figure 17. Acknowledgement of the I<sup>2</sup>C-bus

### 7.5 I<sup>2</sup>C-bus controller

The PCF8576D acts as an I<sup>2</sup>C-bus target receiver. It does not initiate I<sup>2</sup>C-bus transfers or transmit data to an I<sup>2</sup>C-bus controller receiver. The only data output from the PCF8576D are the acknowledge signals of the selected devices. Device selection depends on the I<sup>2</sup>C-bus target address, on the transferred command data and on the hardware subaddress.

In single device applications, the hardware subaddress inputs A0, A1, and A2 are normally tied to V<sub>SS</sub> which defines the hardware subaddress 0. In multiple device applications A0, A1, and A2 are tied to V<sub>SS</sub> or V<sub>DD</sub> using a binary coding scheme, so that no two devices with a common I<sup>2</sup>C-bus target address have the same hardware subaddress.

7.6 Input filters

To enhance noise immunity in electrically adverse environments, RC low-pass filters are provided on the SDA and SCL lines.

7.7 I<sup>2</sup>C-bus protocol

Two I<sup>2</sup>C-bus target addresses (0111 000 and 0111 001) are used to address the PCF8576D. The entire I<sup>2</sup>C-bus target address byte is shown in Table 16.

Table 16. I<sup>2</sup>C controller address byte

		controller address							
Bit	7	6	5	4	3	2	1	0	
	MSB							LSB	
	0	1	1	1	0	0	SA0	R/W	

The PCF8576D is a write-only device and will not respond to a read access, therefore bit 0 should always be logic 0. Bit 1 of the target address byte that a PCF8576D will respond to, is defined by the level tied to its SA0 input (V<sub>SS</sub> for logic 0 and V<sub>DD</sub> for logic 1).

Having two reserved target addresses allows the following on the same I<sup>2</sup>C-bus:

- Up to 16 PCF8576D for very large LCD applications
- The use of two types of LCD multiplex drive

The I<sup>2</sup>C-bus protocol is shown in Figure 18. The sequence is initiated with a START condition (S) from the I<sup>2</sup>C-bus controller which is followed by one of two possible PCF8576D target addresses available. All PCF8576Ds whose SA0 inputs correspond to bit 0 of the target address respond by asserting an acknowledge in parallel. This I<sup>2</sup>C-bus transfer is ignored by all PCF8576Ds whose SA0 inputs are set to the alternative level.

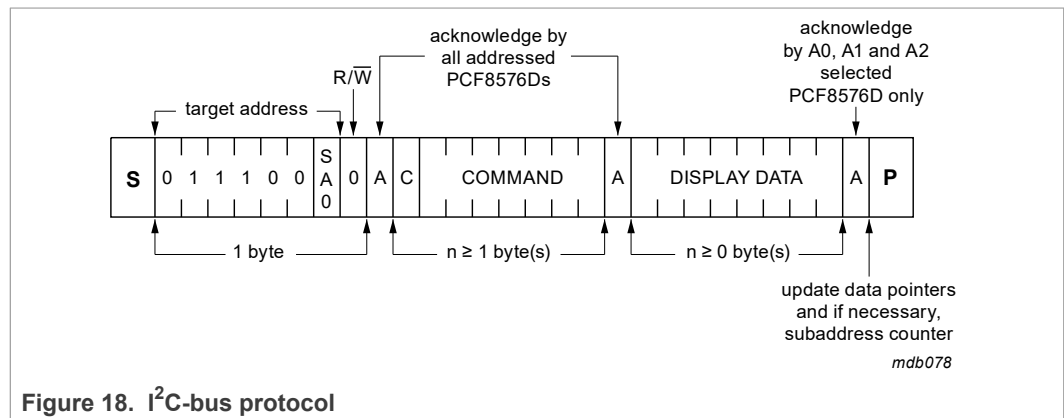

After an acknowledgement, one or more command bytes follow, that define the status of each addressed PCF8576D.

The last command byte sent is identified by resetting its most significant bit, continuation bit C, (see Figure 19). The command bytes are also acknowledged by all addressed PCF8576D on the bus.

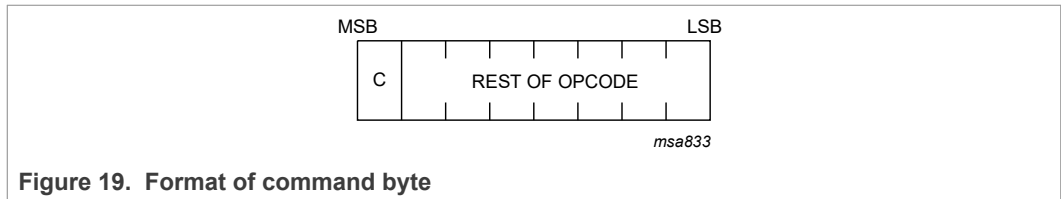

Figure 19. Format of command byte

After the last command byte, one or more display data bytes may follow. Display data bytes are stored in the display RAM at the address specified by the data pointer and the subaddress counter. Both data pointer and subaddress counter are automatically updated and the data directed to the intended PCF8576D device.

An acknowledgement after each byte is asserted only by the PCF8576Ds that are addressed via address lines A0, A1, and A2. After the last display byte, the I<sup>2</sup>C-bus controller asserts a STOP condition (P). Alternately a START may be asserted to restart an I<sup>2</sup>C-bus access.

## 8 Internal circuitry

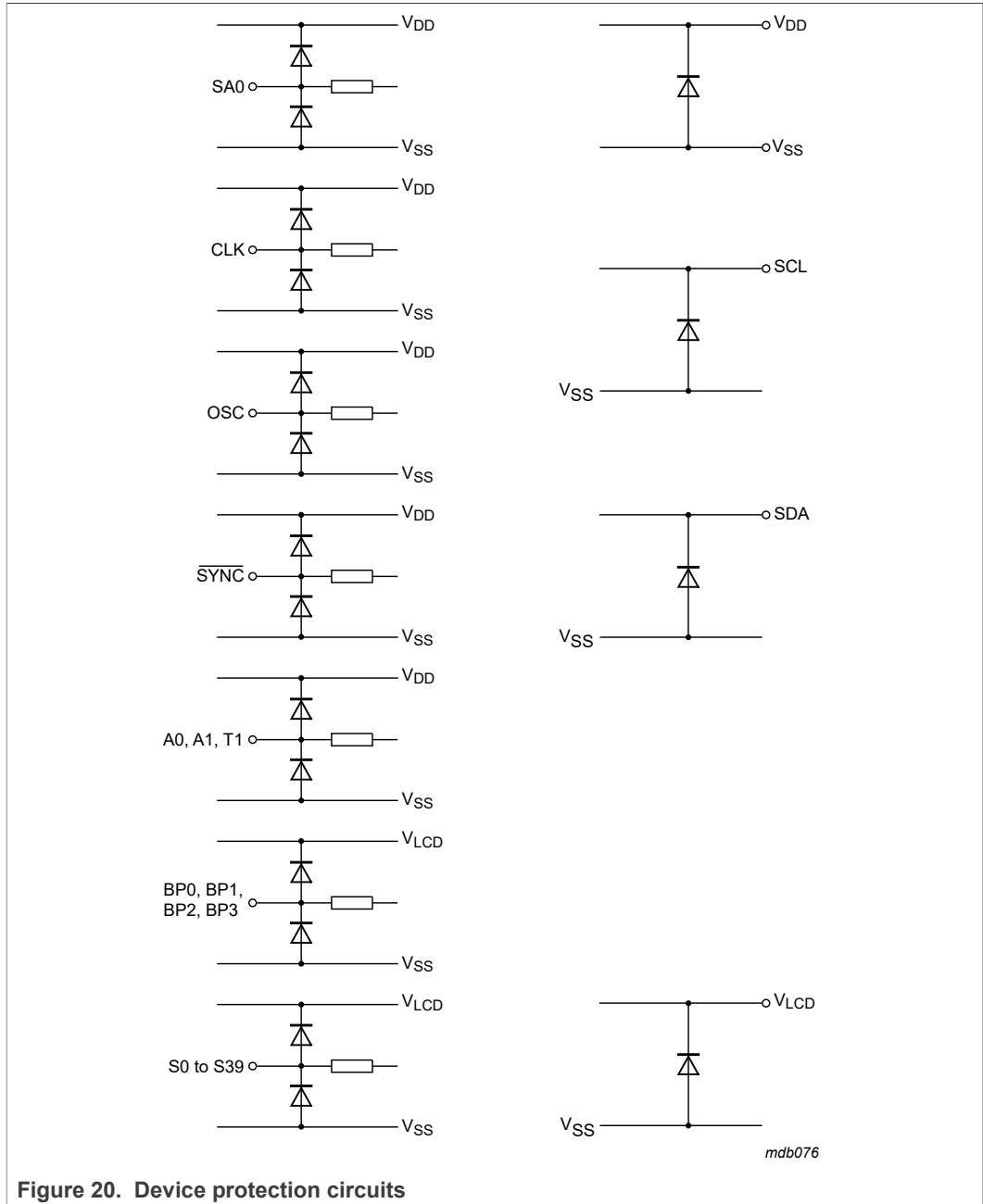

Figure 20. Device protection circuits

## 9 Safety notes

**CAUTION**



This device is sensitive to ElectroStatic Discharge (ESD). Observe precautions for handling electrostatic sensitive devices. Such precautions are described in the *ANSI/ESD S20.20*, *IEC/ST 61340-5*, *JESD625-A* or equivalent standards.

## CAUTION



Static voltages across the liquid crystal display can build up when the LCD supply voltage ( $V_{LCD}$ ) is on while the IC supply voltage ( $V_{DD}$ ) is off, or vice versa. This may cause unwanted display artifacts. To avoid such artifacts,  $V_{LCD}$  and  $V_{DD}$  must be applied or removed together.

## CAUTION



Semiconductors are light sensitive. Exposure to light sources can cause the IC to malfunction. The IC must be protected against light. The protection must be applied to all sides of the IC.

## 10 Limiting values

Table 17. Limiting values

In accordance with the Absolute Maximum Rating System (IEC 60134).

Symbol	Parameter	Conditions	Min	Max	Unit	
$V_{DD}$	supply voltage		-0.5	+6.5	V	
$V_{LCD}$	LCD supply voltage		-0.5	+7.5	V	
$V_I$	input voltage	on each of the pins CLK, SDA, SCL, $\overline{SYNC}$ , SA0, OSC, A0 to A2	-0.5	+6.5	V	
$V_O$	output voltage	on each of the pins S0 to S39, BP0 to BP3	-0.5	+7.5	V	
$I_I$	input current		-10	+10	mA	
$I_O$	output current		-10	+10	mA	
$I_{DD}$	supply current		-50	+50	mA	
$I_{DD(LCD)}$	LCD supply current		-50	+50	mA	
$I_{SS}$	ground supply current		-50	+50	mA	
$P_{tot}$	total power dissipation		-	400	mW	
$P_o$	output power		-	100	mW	
$V_{ESD}$	electrostatic discharge voltage	HBM	[1]	-	±5 000	V
		MM	[2]	-	±200	V
		CDM	[3]	-	±1 500	V
$I_{lu}$	latch-up current		[4]	-	200	mA
$T_{stg}$	storage temperature		[5]	-65	+150	°C
$T_{amb}$	ambient temperature	operating device		-40	+85	°C

[1] Pass level; Human Body Model (HBM) according to [1].

[2] Pass level; Machine Model (MM), according to [2].

[3] Pass level; Charged-Device Model (CDM), according to [3].

[4] Pass level; latch-up testing according to [4] at maximum ambient temperature ( $T_{amb(max)}$ ).

[5] According to the store and transport requirements (see [6]) the devices have to be stored at a temperature of +8 °C to +45 °C and a humidity of 25 % to 75 %.

## 11 Static characteristics

**Table 18. Static characteristics**
 $V_{DD} = 1.8\text{ V to }5.5\text{ V}; V_{SS} = 0\text{ V}; V_{LCD} = 2.5\text{ V to }6.5\text{ V}; T_{amb} = -40\text{ }^{\circ}\text{C to }+85\text{ }^{\circ}\text{C};$  unless otherwise specified.

Symbol	Parameter	Conditions	Min	Typ	Max	Unit
<b>Supplies</b>						
$V_{DD}$	supply voltage		1.8	-	5.5	V
$V_{LCD}$	LCD supply voltage		[1] 2.5	-	6.5	V
$I_{DD}$	supply current	$f_{clk(ext)} = 1536\text{ Hz}$	[2] -	3.5	7	$\mu\text{A}$
		$V_{DD} = 3.0\text{ V}; T_{amb} = 25\text{ }^{\circ}\text{C}$	-	2.7	-	$\mu\text{A}$
$I_{DD(LCD)}$	LCD supply current	$f_{clk(ext)} = 1536\text{ Hz}$	[2] -	23	32	$\mu\text{A}$
		$V_{DD(LCD)} = 3.0\text{ V}; T_{amb} = 25\text{ }^{\circ}\text{C}$	-	13	-	$\mu\text{A}$
<b>Logic</b> <sup>[3]</sup>						
$V_{P(POR)}$	power-on reset supply voltage		1.0	1.3	1.6	V
$V_{IL}$	LOW-level input voltage	on pins CLK, $\overline{\text{SYNC}}$ , OSC, A0 to A2, SA0, SCL, SDA	$V_{SS}$	-	$0.3V_{DD}$	V
$V_{IH}$	HIGH-level input voltage	on pins CLK, $\overline{\text{SYNC}}$ , OSC, A0 to A2, SA0, SCL, SDA	[4][5] $0.7V_{DD}$	-	$V_{DD}$	V
$I_{OL}$	LOW-level output current	output sink current; $V_{OL} = 0.4\text{ V}; V_{DD} = 5\text{ V}$				
		on pins CLK and $\overline{\text{SYNC}}$	1	-	-	mA
		on pin SDA	3	-	-	mA
$I_{OH(CLK)}$	HIGH-level output current on pin CLK	output source current; $V_{OH} = 4.6\text{ V}; V_{DD} = 5\text{ V}$	1	-	-	mA
$I_L$	leakage current	$V_I = V_{DD}$ or $V_{SS}$ ; on pins CLK, SCL, SDA, A0 to A2 and SA0	-1	-	+1	$\mu\text{A}$
$I_{L(OSC)}$	leakage current on pin OSC	$V_I = V_{DD}$	-1	-	+1	$\mu\text{A}$
$C_I$	input capacitance		[6] -	-	7	pF
<b>LCD outputs</b>						
$\Delta V_O$	output voltage variation	on pins BP0 to BP3 and S0 to S39	-100	-	+100	mV
$R_O$	output resistance	$V_{LCD} = 5\text{ V}$	[7]			
		on pins BP0 to BP3	-	1.5	-	k $\Omega$
		on pins S0 to S39	-	6.0	-	k $\Omega$

[1]  $V_{LCD} > 3\text{ V}$  for  $\frac{1}{3}$  bias.

[2] LCD outputs are open-circuit; inputs at  $V_{SS}$  or  $V_{DD}$ ; external clock with 50 % duty factor; I<sup>2</sup>C-bus inactive.

[3] The I<sup>2</sup>C-bus interface of PCF8576D is 5 V tolerant.

[4] When tested, I<sup>2</sup>C pins SCL and SDA have no diode to  $V_{DD}$  and may be driven to the  $V_I$  limiting values given in [Table 17](#).

[5] Propagation delay of driver between clock (CLK) and LCD driving signals.

[6] Periodically sampled, not 100 % tested.  
 [7] Outputs measured one at a time.

## 12 Dynamic characteristics

**Table 19. Dynamic characteristics**

$V_{DD} = 1.8\text{ V to }5.5\text{ V}$ ;  $V_{SS} = 0\text{ V}$ ;  $V_{LCD} = 2.5\text{ V to }6.5\text{ V}$ ;  $T_{amb} = -40\text{ °C to }+85\text{ °C}$ ; unless otherwise specified.

Symbol	Parameter	Conditions	Min	Typ	Max	Unit
<b>Clock</b>						
$f_{clk(int)}$	internal clock frequency		[1] 1440	1850	2640	Hz
$f_{clk(ext)}$	external clock frequency		960	-	2640	Hz
$t_{clk(H)}$	HIGH-level clock time		60	-	-	µs
$t_{clk(L)}$	LOW-level clock time		60	-	-	µs
<b>Synchronization</b>						
$t_{PD(SYNC\_N)}$	$\overline{SYNC}$ propagation delay		-	30	-	ns
$t_{SYNC\_NL}$	$\overline{SYNC}$ LOW time		1	-	-	µs
$t_{PD(drv)}$	driver propagation delay	$V_{LCD} = 5\text{ V}$	[2] -	-	30	µs
$I^2C$ -bus <sup>[3]</sup>						
Pin SCL						
$f_{SCL}$	SCL clock frequency		-	-	400	kHz
$t_{LOW}$	LOW period of the SCL clock		1.3	-	-	µs
$t_{HIGH}$	HIGH period of the SCL clock		0.6	-	-	µs
Pin SDA						
$t_{SU;DAT}$	data set-up time		100	-	-	ns
$t_{HD;DAT}$	data hold time		0	-	-	ns
Pins SCL and SDA						
$t_{BUF}$	bus free time between a STOP and START condition		1.3	-	-	µs
$t_{SU;STO}$	set-up time for STOP condition		0.6	-	-	µs
$t_{HD;STA}$	hold time (repeated) START condition		0.6	-	-	µs
$t_{SU;STA}$	set-up time for a repeated START condition		0.6	-	-	µs
$t_r$	rise time of both SDA and SCL signals	$f_{SCL} = 400\text{ kHz}$	-	-	0.3	µs
		$f_{SCL} < 125\text{ kHz}$	-	-	1.0	µs
$t_f$	fall time of both SDA and SCL signals		-	-	0.3	µs
$C_b$	capacitive load for each bus line		-	-	400	pF

Table 19. Dynamic characteristics...continued

$V_{DD} = 1.8\text{ V to }5.5\text{ V}$ ;  $V_{SS} = 0\text{ V}$ ;  $V_{LCD} = 2.5\text{ V to }6.5\text{ V}$ ;  $T_{amb} = -40\text{ }^{\circ}\text{C to }+85\text{ }^{\circ}\text{C}$ ; unless otherwise specified.

Symbol	Parameter	Conditions	Min	Typ	Max	Unit
$t_{w(\text{spike})}$	spike pulse width	on the I <sup>2</sup> C-bus	-	-	50	ns

- [1] Typical output duty factor: 50 % measured at the CLK output pin.
- [2] Not tested in production.
- [3] All timing values are valid within the operating supply voltage and ambient temperature range and are referenced to  $V_{IL}$  and  $V_{IH}$  with an input voltage swing of  $V_{SS}$  to  $V_{DD}$ .

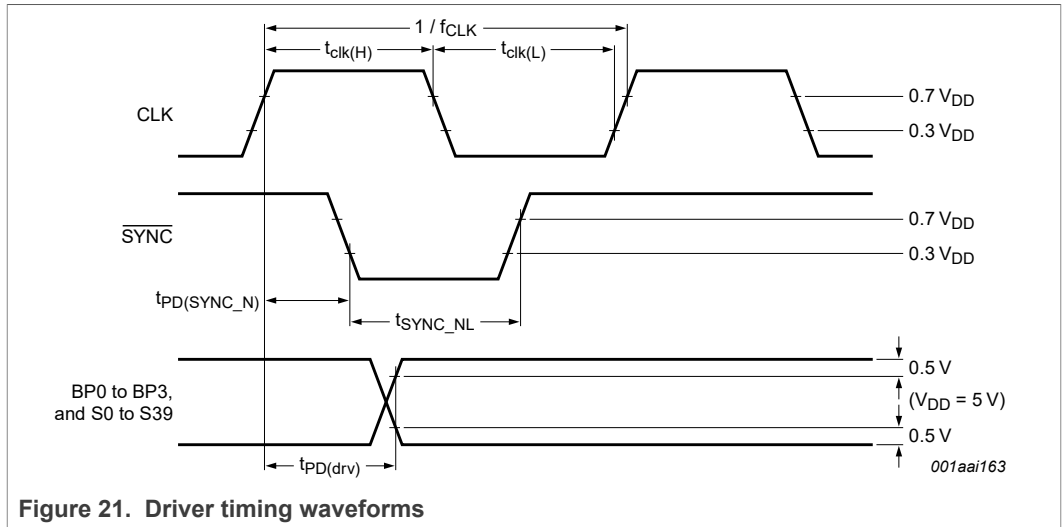

Figure 21. Driver timing waveforms

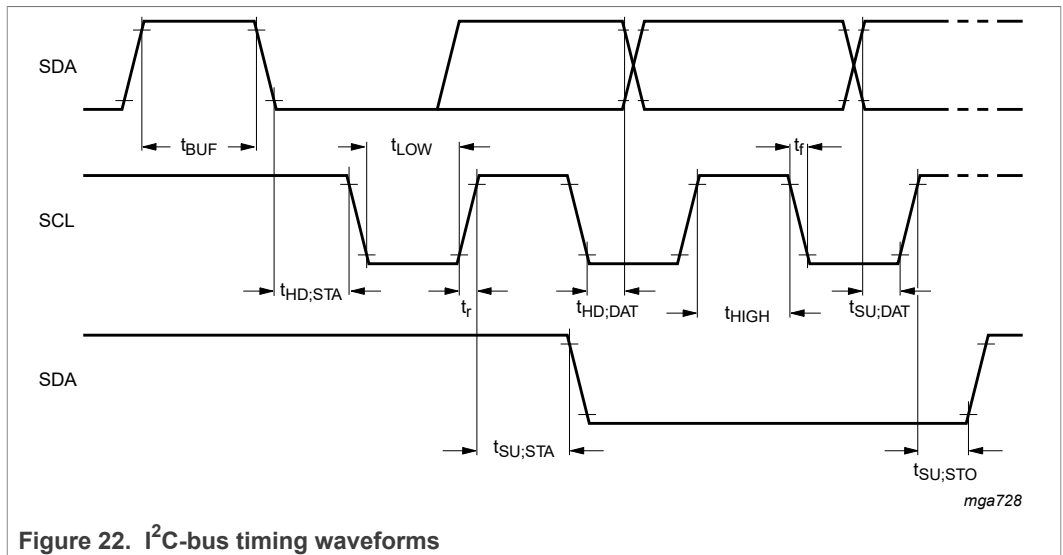

Figure 22. I<sup>2</sup>C-bus timing waveforms

## 13 Application information

### 13.1 Cascaded operation

In large display configurations, up to 16 PCF8576Ds can be differentiated on the same I<sup>2</sup>C-bus by using the 3-bit hardware subaddresses (A0, A1 and A2) and the programmable I<sup>2</sup>C-bus target address (SA0).

Table 20. Addressing cascaded PCF8576D

Cluster	Bit SA0	Pin A2	Pin A1	Pin A0	Device
1	0	0	0	0	0
		0	0	1	1
		0	1	0	2
		0	1	1	3
		1	0	0	4
		1	0	1	5
		1	1	0	6
		1	1	1	7
2	1	0	0	0	8
		0	0	1	9
		0	1	0	10
		0	1	1	11
		1	0	0	12
		1	0	1	13
		1	1	0	14
		1	1	1	15

PCF8576Ds connected in cascade are synchronized to allow the backplane signals from only one device in the cascade to be shared. This arrangement is cost-effective in large LCD applications since the backplane outputs of only one device need to be through-plated to the backplane electrodes of the display. The other PCF8576D of the cascade contribute additional segment outputs. The backplanes can either be connected together to enhance the drive capability or some can be left open-circuit (such as the ones from the target in [Figure 23](#)) or just some of the controller and some of the target will be taken to facilitate the layout of the display.

All PCF8576Ds connected in cascade are correctly synchronized by the  $\overline{\text{SYNC}}$  signal. This synchronization is guaranteed after the power-on reset. The only time that  $\overline{\text{SYNC}}$  is likely to be needed is if synchronization is lost accidentally, for example, by noise in adverse electrical environments, or if the LCD multiplex drive mode is changed in an application using several cascaded PCF8576Ds, as the drive mode cannot be changed on all of the cascaded devices simultaneously.  $\overline{\text{SYNC}}$  can be either an input or an output signal; a  $\overline{\text{SYNC}}$  output is implemented as an open-drain driver with an internal pull-up resistor. The PCF8576D asserts  $\overline{\text{SYNC}}$  at the start of its last active backplane signal and monitors the  $\overline{\text{SYNC}}$  line at all other times. If cascade synchronization is lost, it is restored

by the first PCF8576D to assert  $\overline{\text{SYNC}}$ . The timing relationship between the backplane waveforms and the  $\overline{\text{SYNC}}$  signal for each LCD drive mode is shown in [Figure 24](#).

The contact resistance between the  $\overline{\text{SYNC}}$  on each cascaded device must be controlled. If the resistance is too high, the device is not able to synchronize properly; this is particularly applicable to chip-on-glass applications. The maximum  $\overline{\text{SYNC}}$  contact resistance allowed for the number of devices in cascade is given in [Table 21](#).

Table 21.  $\overline{\text{SYNC}}$  contact resistance

Number of devices	Maximum contact resistance
2	6 kΩ
3 to 5	2.2 kΩ
6 to 10	1.2 kΩ
10 to 16	700 Ω

The PCF8576D can be cascaded with the PCF8562. This allows optimal drive selection for a given number of pixels to display. [Figure 21](#) and [Figure 22](#) show the timing of the synchronization signals.

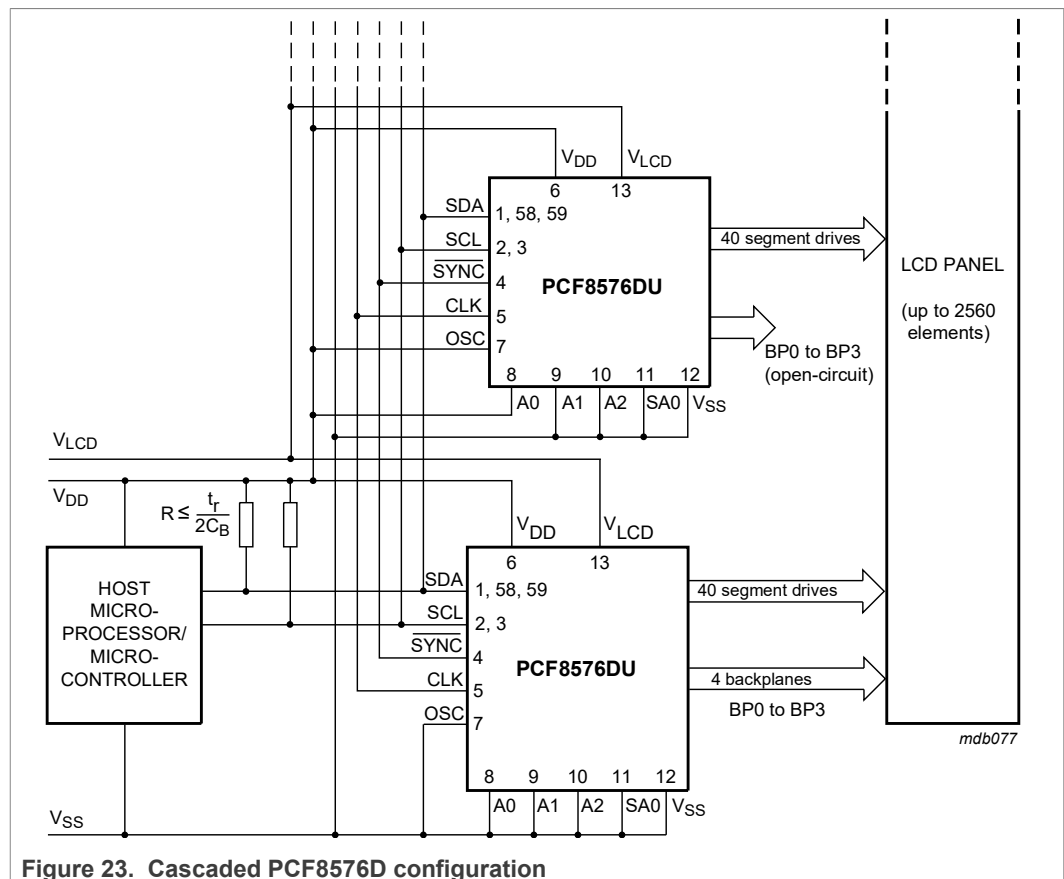
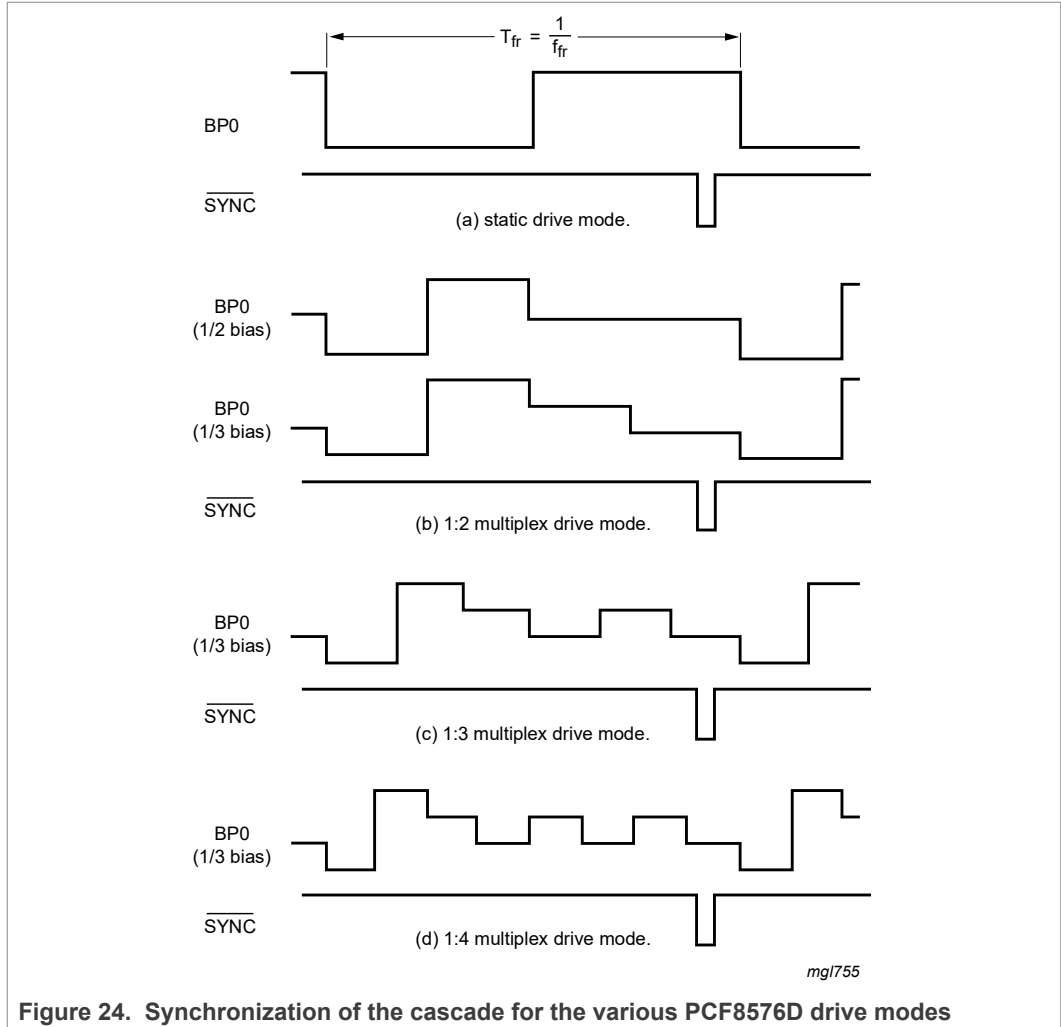

Figure 23. Cascaded PCF8576D configuration



## 14 Test information

The following quality information corresponds with the product type: PCF8576DT/S400/2

### 14.1 Quality information

This product has been qualified in accordance with the Automotive Electronics Council (AEC) standard Q100 - *Failure mechanism based stress test qualification for integrated circuits*, and is suitable for use in automotive applications.

15 Package outline

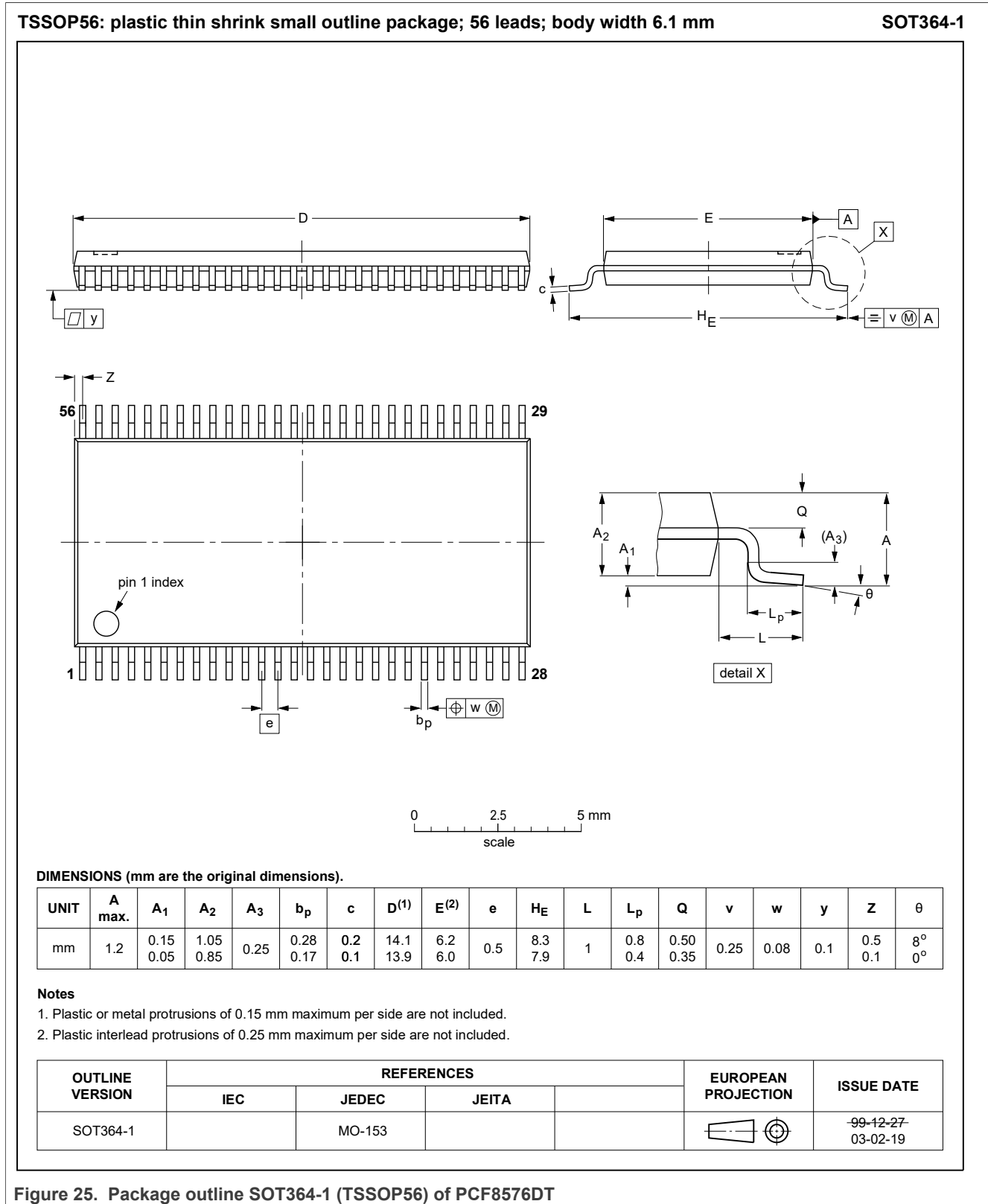
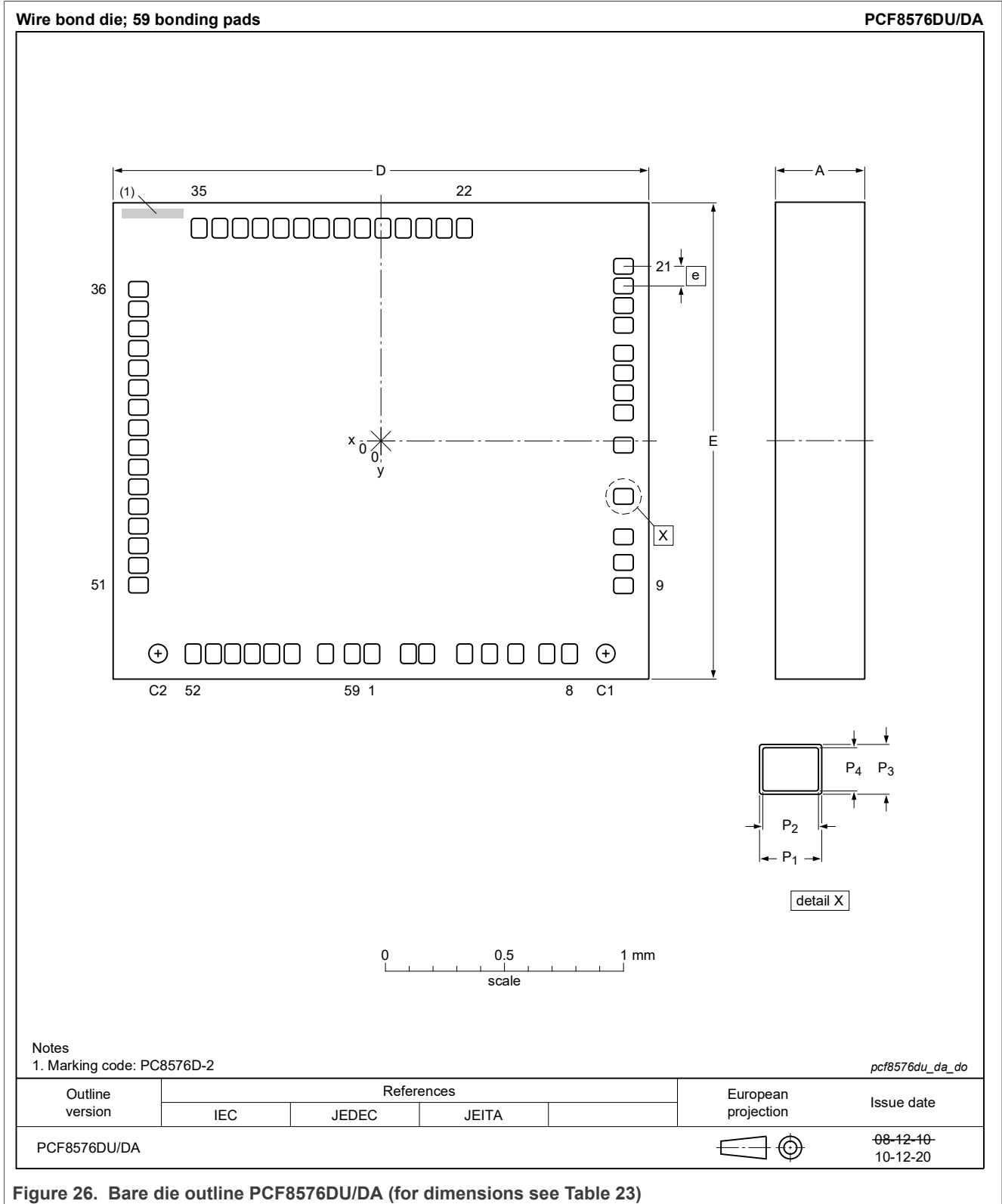

Figure 25. Package outline SOT364-1 (TSSOP56) of PCF8576DT

16 Bare die outline



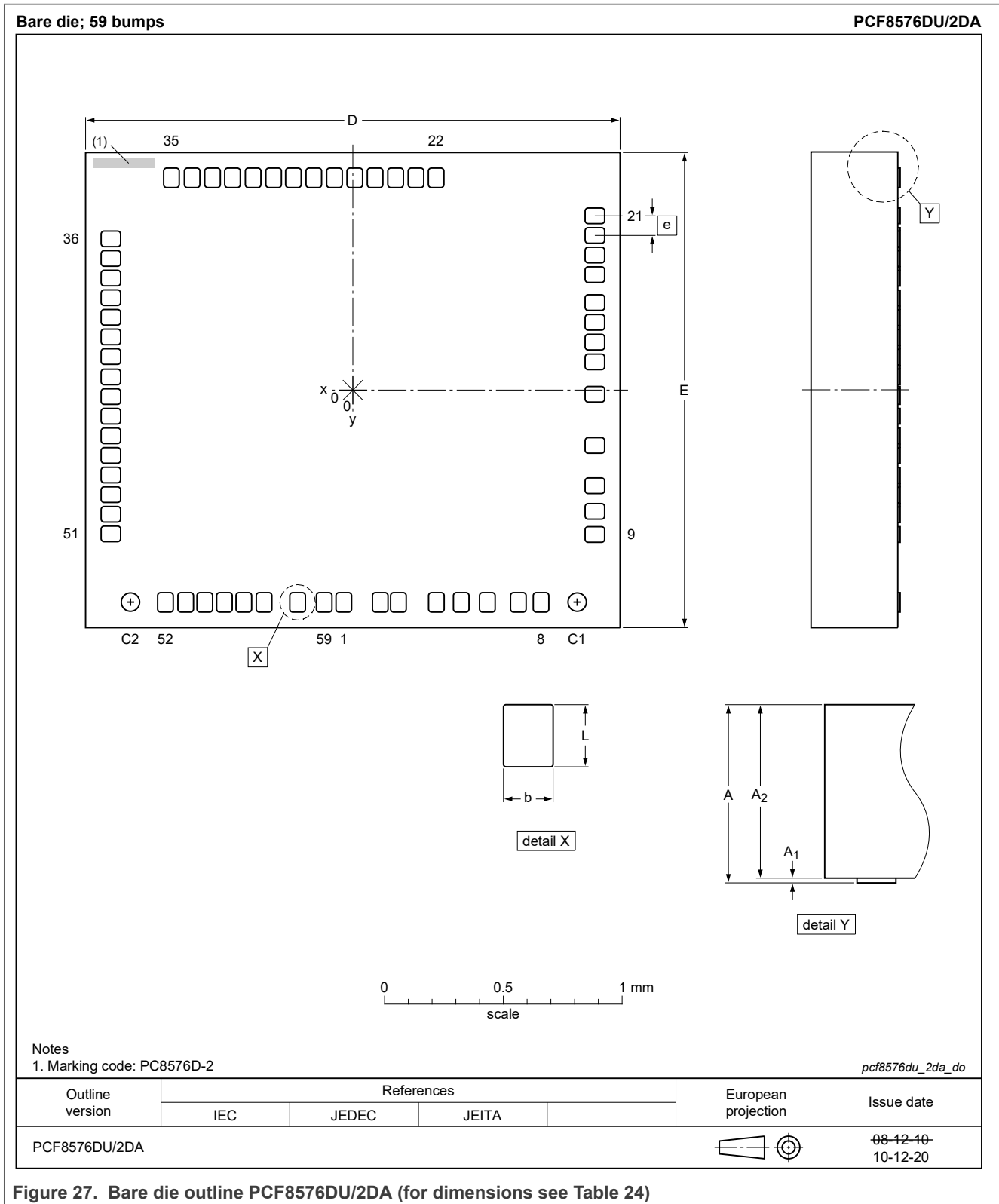

Figure 27. Bare die outline PCF8576DU/2DA (for dimensions see Table 24)

Table 22. Dimensions of PCF8576DU/DA

Original dimensions are in mm.

Unit (mm)	A	D	E	e <sup>[1]</sup>	P <sub>1</sub> <sup>[2]</sup>	P <sub>2</sub> <sup>[3]</sup>	P <sub>3</sub> <sup>[2]</sup>	P <sub>4</sub> <sup>[3]</sup>
max	-	-	-	-	-	-	-	-
nom	0.38	2.2	2.0	-	0.09	0.08	0.066	0.056
min	-	-	-	0.072	-	-	-	-

[1] Dimension not drawn to scale.

[2] Pad size.

[3] Passivation opening.

Table 23. Dimensions of PCF8576DU/2DA

Original dimensions are in mm.

Unit (mm)	A	A <sub>1</sub>	A <sub>2</sub>	b	D	E	e <sup>[1]</sup>	L
max	-	0.012	-	-	-	-	-	-
nom	0.40	0.015	0.381	0.052	2.2	2.0	-	0.077
min	-	0.018	-	-	-	-	0.072	-

[1] Dimension not drawn to scale.

Table 24. Bonding pad location for PCF8576DU/x

All x/y coordinates represent the position of the center of each pad with respect to the center (x/y = 0) of the chip (see [Figure 3](#), [Figure 26](#) and [Figure 27](#)).

Symbol	Pad	X (μm)	Y (μm)	Description
SDA	1	-34.38	-876.6	I <sup>2</sup> C-bus serial data input/output
SCL	2	109.53	-876.6	I <sup>2</sup> C-bus serial clock input
SCL	3	181.53	-876.6	
SYNC	4	365.58	-876.6	cascade synchronization input/output
CLK	5	469.08	-876.6	external clock input/output
V <sub>DD</sub>	6	577.08	-876.6	supply voltage
OSC	7	740.88	-876.6	internal oscillator enable input
A0	8	835.83	-876.6	subaddress inputs
A1	9	1 005.48	-630.9	
A2	10	1 005.48	-513.9	
SA0	11	1 005.48	-396.9	I <sup>2</sup> C-bus address input; bit 0
V <sub>SS</sub>	12	1 005.48	-221.4	ground supply voltage
V <sub>LCD</sub>	13	1 005.48	10.71	LCD supply voltage
BP0	14	1 005.48	156.51	LCD backplane outputs
BP2	15	1 005.48	232.74	
BP1	16	1 005.48	308.97	
BP3	17	1 005.48	385.2	

Table 24. Bonding pad location for PCF8576DU/x...continued

All x/y coordinates represent the position of the center of each pad with respect to the center (x/y = 0) of the chip (see [Figure 3](#), [Figure 26](#) and [Figure 27](#)).

Symbol	Pad	X (µm)	Y (µm)	Description
S0	18	1 005.48	493.2	LCD segment outputs
S1	19	1 005.48	565.2	
S2	20	1 005.48	637.2	
S3	21	1 005.48	709.2	
S4	22	347.22	876.6	LCD segment outputs
S5	23	263.97	876.6	
S6	24	180.72	876.6	
S7	25	97.47	876.6	
S8	26	14.22	876.6	
S9	27	-69.03	876.6	
S10	28	-152.28	876.6	
S11	29	-235.53	876.6	
S12	30	-318.78	876.6	
S13	31	-402.03	876.6	
S14	32	-485.28	876.6	
S15	33	-568.53	876.6	
S16	34	-651.78	876.6	
S17	35	-735.03	876.6	
S18	36	-1 005.5	625.59	
S19	37	-1 005.5	541.62	
S20	38	-1 005.5	458.19	
S21	39	-1 005.5	374.76	
S22	40	-1 005.5	291.33	
S23	41	-1 005.5	207.9	
S24	42	-1 005.5	124.47	
S25	43	-1 005.5	41.04	
S26	44	-1 005.5	-42.39	
S27	45	-1 005.5	-125.8	
S28	46	-1 005.5	-209.3	
S29	47	-1 005.5	-292.7	
S30	48	-1 005.5	-376.1	
S31	49	-1 005.5	-459.5	
S32	50	-1 005.5	-543	
S33	51	-1 005.5	-625.6	
S34	52	-735.03	-876.6	

**Table 24. Bonding pad location for PCF8576DU/x...continued**

All x/y coordinates represent the position of the center of each pad with respect to the center (x/y = 0) of the chip (see [Figure 3](#), [Figure 26](#) and [Figure 27](#)).

Symbol	Pad	X (μm)	Y (μm)	Description
S35	53	-663.03	-876.6	
S36	54	-591.03	-876.6	
S37	55	-519.03	-876.6	
S38	56	-447.03	-876.6	
S39	57	-375.03	-876.6	
SDA	58	-196.38	-876.6	
SDA	59	-106.38	-876.6	

**Table 25. Alignment marks**

All x/y coordinates represent the position of the center of each alignment mark with respect to the center (x/y = 0) of the chip (see [Figure 3](#), [Figure 26](#) and [Figure 27](#)).

Symbol	Location		Dimension
	X (μm)	Y (μm)	Diameter (μm)
C1	930.42	-870.3	72
C2	-829.98	-870.3	72

## 17 Handling information

All input and output pins are protected against ElectroStatic Discharge (ESD) under normal handling. When handling Metal-Oxide Semiconductor (MOS) devices ensure that all normal precautions are taken as described in *JESD625-A*, *IEC 61340-5* or equivalent standards.

18 Packing information

18.1 Tray information

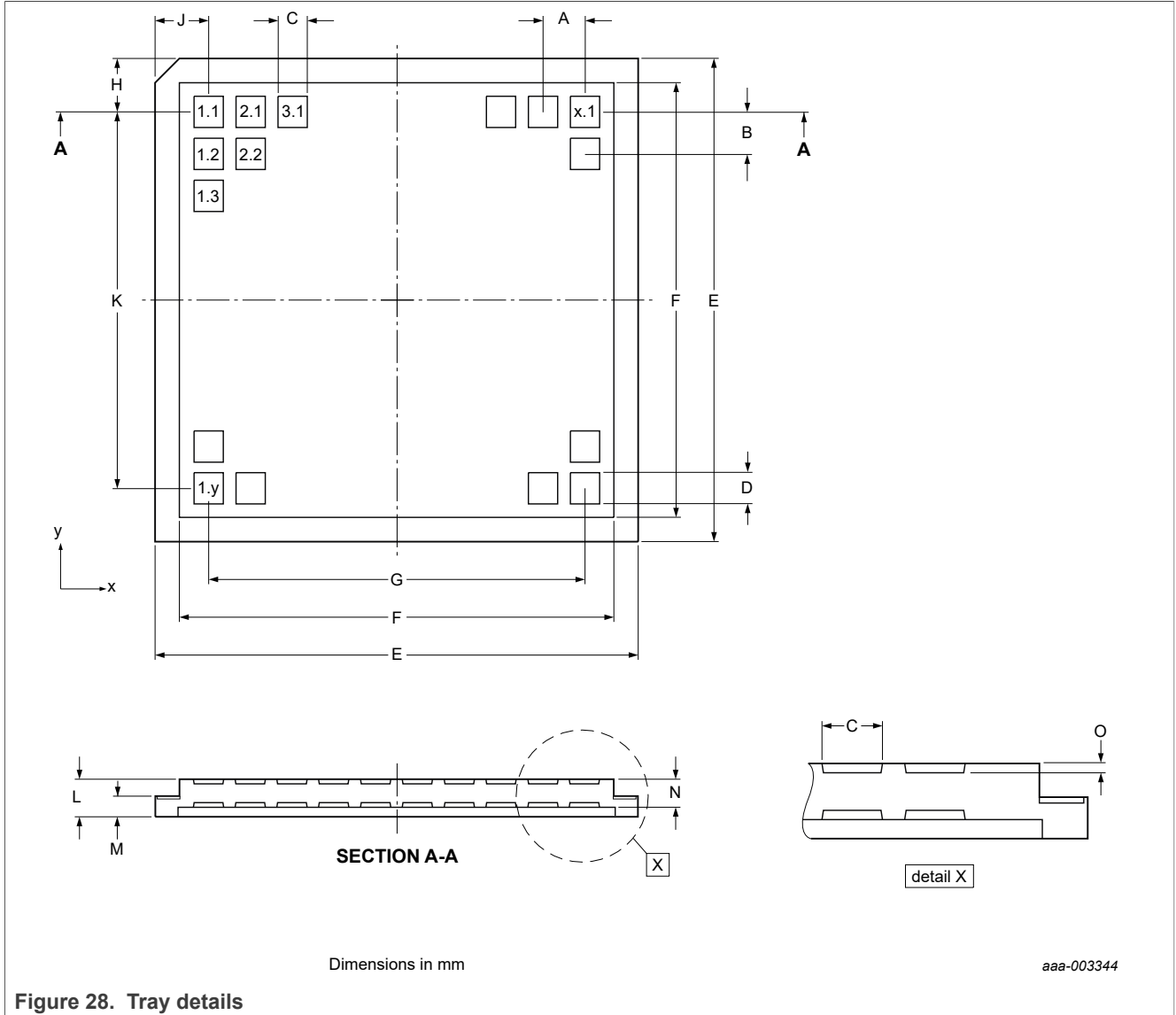

Figure 28. Tray details

Table 26. Description of tray details

Tray details are shown in [Figure 28](#).

Tray details													
Dimensions													
A	B	C	D	E	F	G	H	J	K	L	M	N	Unit
3.6	3.6	2.36	2.11	50.8	45.72	39.6	5.6	5.6	39.6	3.96	2.18	2.49	mm
Number of pockets													

Table 26. Description of tray details...continued

Tray details are shown in [Figure 28](#).

Tray details	
x direction	y direction
12	12

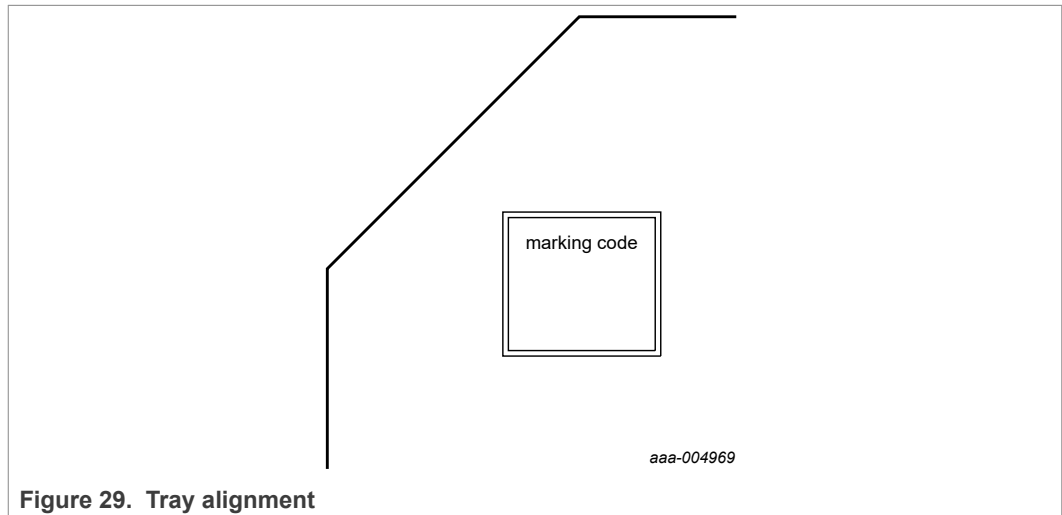

Figure 29. Tray alignment

## 18.2 Tape and reel information

For tape and reel packing information, please see [\[5\]](#).

## 19 Soldering of SMD packages

This text provides a very brief insight into a complex technology. A more in-depth account of soldering ICs can be found in Application Note AN10365 “Surface mount reflow soldering description”.

### 19.1 Introduction to soldering

Soldering is one of the most common methods through which packages are attached to Printed Circuit Boards (PCBs), to form electrical circuits. The soldered joint provides both the mechanical and the electrical connection. There is no single soldering method that is ideal for all IC packages. Wave soldering is often preferred when through-hole and Surface Mount Devices (SMDs) are mixed on one printed wiring board; however, it is not suitable for fine pitch SMDs. Reflow soldering is ideal for the small pitches and high densities that come with increased miniaturization.

### 19.2 Wave and reflow soldering

Wave soldering is a joining technology in which the joints are made by solder coming from a standing wave of liquid solder. The wave soldering process is suitable for the following:

- Through-hole components

- Leaded or leadless SMDs, which are glued to the surface of the printed circuit board

Not all SMDs can be wave soldered. Packages with solder balls, and some leadless packages which have solder lands underneath the body, cannot be wave soldered. Also, leaded SMDs with leads having a pitch smaller than ~0.6 mm cannot be wave soldered, due to an increased probability of bridging.

The reflow soldering process involves applying solder paste to a board, followed by component placement and exposure to a temperature profile. Leaded packages, packages with solder balls, and leadless packages are all reflow solderable.

Key characteristics in both wave and reflow soldering are:

- Board specifications, including the board finish, solder masks and vias
- Package footprints, including solder thieves and orientation
- The moisture sensitivity level of the packages
- Package placement
- Inspection and repair
- Lead-free soldering versus SnPb soldering

### 19.3 Wave soldering

Key characteristics in wave soldering are:

- Process issues, such as application of adhesive and flux, clinching of leads, board transport, the solder wave parameters, and the time during which components are exposed to the wave
- Solder bath specifications, including temperature and impurities

### 19.4 Reflow soldering

Key characteristics in reflow soldering are:

- Lead-free versus SnPb soldering; note that a lead-free reflow process usually leads to higher minimum peak temperatures (see [Figure 30](#)) than a SnPb process, thus reducing the process window
- Solder paste printing issues including smearing, release, and adjusting the process window for a mix of large and small components on one board
- Reflow temperature profile; this profile includes preheat, reflow (in which the board is heated to the peak temperature) and cooling down. It is imperative that the peak temperature is high enough for the solder to make reliable solder joints (a solder paste characteristic). In addition, the peak temperature must be low enough that the packages and/or boards are not damaged. The peak temperature of the package depends on package thickness and volume and is classified in accordance with [Table 27](#) and [Table 28](#)

Table 27. SnPb eutectic process (from J-STD-020D)

Package thickness (mm)	Package reflow temperature (°C)	
	Volume (mm³)	
	< 350	≥ 350
< 2.5	235	220
≥ 2.5	220	220

Table 28. Lead-free process (from J-STD-020D)

Package thickness (mm)	Package reflow temperature (°C)		
	Volume (mm <sup>3</sup> )		
	< 350	350 to 2000	> 2000
< 1.6	260	260	260
1.6 to 2.5	260	250	245
> 2.5	250	245	245

Moisture sensitivity precautions, as indicated on the packing, must be respected at all times.

Studies have shown that small packages reach higher temperatures during reflow soldering, see [Figure 30](#).

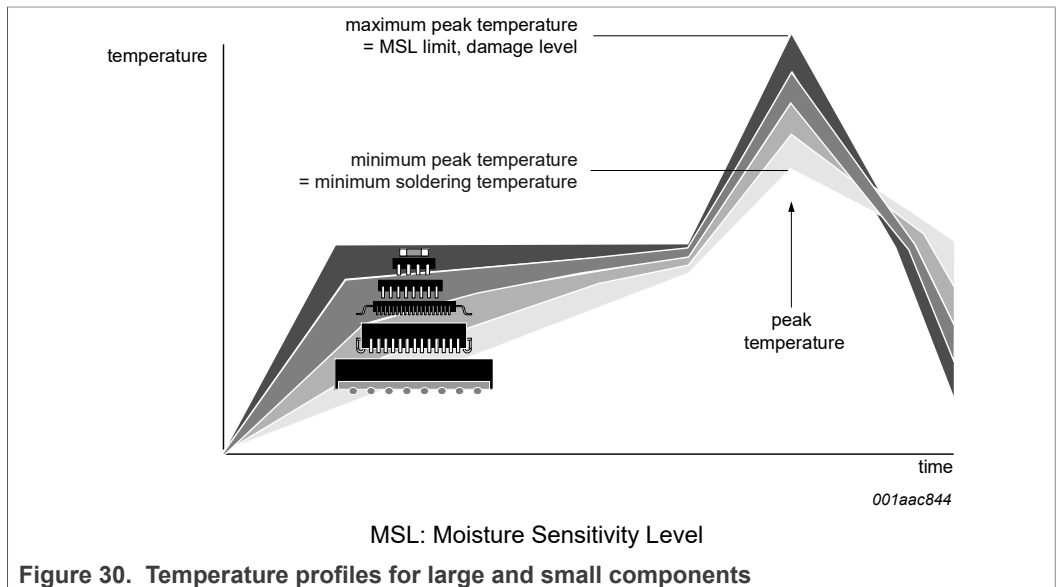

Figure 30. Temperature profiles for large and small components

For further information on temperature profiles, refer to Application Note AN10365 “Surface mount reflow soldering description”.

## 20 Appendix

### 20.1 LCD segment driver selection

Table 29. Selection of LCD segment drivers

Type name	Number of elements at MUX							V <sub>DD</sub> (V)	V <sub>LCD</sub> (V)	f <sub>fr</sub> (Hz)	V <sub>LCD</sub> (V) charge pump	V <sub>LCD</sub> (V) temperature compensat.	T <sub>amb</sub> (°C)	Interface	Package	AEC- Q100
	1:1	1:2	1:3	1:4	1:6	1:8	1:9									
PCA8553DTT	40	80	120	160	-	-	-	1.8 to 5.5	1.8 to 5.5	32 to 256 <sup>[1]</sup>	N	N	-40 to 105	I <sup>2</sup> C / SPI	TSSOP56	Y
PCA8546ATT	-	-	-	176	-	-	-	1.8 to 5.5	2.5 to 9	60 to 300 <sup>[1]</sup>	N	N	-40 to 95	I <sup>2</sup> C	TSSOP56	Y
PCA8546BTT	-	-	-	176	-	-	-	1.8 to 5.5	2.5 to 9	60 to 300 <sup>[1]</sup>	N	N	-40 to 95	SPI	TSSOP56	Y
PCA8547AHT	44	88	-	176	-	-	-	1.8 to 5.5	2.5 to 9	60 to 300 <sup>[1]</sup>	Y	Y	-40 to 95	I <sup>2</sup> C	TQFP64	Y
PCA8547BHT	44	88	-	176	-	-	-	1.8 to 5.5	2.5 to 9	60 to 300 <sup>[1]</sup>	Y	Y	-40 to 95	SPI	TQFP64	Y
PCF85134HL	60	120	180	240	-	-	-	1.8 to 5.5	2.5 to 6.5	82	N	N	-40 to 85	I <sup>2</sup> C	LQFP80	N
PCA85134H	60	120	180	240	-	-	-	1.8 to 5.5	2.5 to 8	82	N	N	-40 to 95	I <sup>2</sup> C	LQFP80	Y
PCA8543AHL	60	120	-	240	-	-	-	2.5 to 5.5	2.5 to 9	60 to 300 <sup>[1]</sup>	Y	Y	-40 to 105	I <sup>2</sup> C	LQFP80	Y
PCF8545ATT	-	-	-	176	252	320	-	1.8 to 5.5	2.5 to 5.5	60 to 300 <sup>[1]</sup>	N	N	-40 to 85	I <sup>2</sup> C	TSSOP56	N
PCF8545BTT	-	-	-	176	252	320	-	1.8 to 5.5	2.5 to 5.5	60 to 300 <sup>[1]</sup>	N	N	-40 to 85	SPI	TSSOP56	N
PCF8536AT	-	-	-	176	252	320	-	1.8 to 5.5	2.5 to 9	60 to 300 <sup>[1]</sup>	N	N	-40 to 85	I <sup>2</sup> C	TSSOP56	N
PCF8536BT	-	-	-	176	252	320	-	1.8 to 5.5	2.5 to 9	60 to 300 <sup>[1]</sup>	N	N	-40 to 85	SPI	TSSOP56	N
PCA8536AT	-	-	-	176	252	320	-	1.8 to 5.5	2.5 to 9	60 to 300 <sup>[1]</sup>	N	N	-40 to 95	I <sup>2</sup> C	TSSOP56	Y
PCA8536BT	-	-	-	176	252	320	-	1.8 to 5.5	2.5 to 9	60 to 300 <sup>[1]</sup>	N	N	-40 to 95	SPI	TSSOP56	Y
PCF8537AH	44	88	-	176	276	352	-	1.8 to 5.5	2.5 to 9	60 to 300 <sup>[1]</sup>	Y	Y	-40 to 85	I <sup>2</sup> C	TQFP64	N
PCF8537BH	44	88	-	176	276	352	-	1.8 to 5.5	2.5 to 9	60 to 300 <sup>[1]</sup>	Y	Y	-40 to 85	SPI	TQFP64	N
PCA8537AH	44	88	-	176	276	352	-	1.8 to 5.5	2.5 to 9	60 to 300 <sup>[1]</sup>	Y	Y	-40 to 95	I <sup>2</sup> C	TQFP64	Y
PCA8537BH	44	88	-	176	276	352	-	1.8 to 5.5	2.5 to 9	60 to 300 <sup>[1]</sup>	Y	Y	-40 to 95	SPI	TQFP64	Y
PCA9620H	60	120	-	240	320	480	-	2.5 to 5.5	2.5 to 9	60 to 300 <sup>[1]</sup>	Y	Y	-40 to 105	I <sup>2</sup> C	LQFP80	Y
PCA9620U	60	120	-	240	320	480	-	2.5 to 5.5	2.5 to 9	60 to 300 <sup>[1]</sup>	Y	Y	-40 to 105	I <sup>2</sup> C	Bare die	Y
PCF8576DU	40	80	120	160	-	-	-	1.8 to 5.5	2.5 to 6.5	77	N	N	-40 to 85	I <sup>2</sup> C	Bare die	N
PCF8576EUG	40	80	120	160	-	-	-	1.8 to 5.5	2.5 to 6.5	77	N	N	-40 to 85	I <sup>2</sup> C	Bare die	N
PCA8576FUG	40	80	120	160	-	-	-	1.8 to 5.5	2.5 to 8	200	N	N	-40 to 105	I <sup>2</sup> C	Bare die	Y
PCF85133U	80	160	240	320	-	-	-	1.8 to 5.5	2.5 to 6.5	82, 110 <sup>[2]</sup>	N	N	-40 to 85	I <sup>2</sup> C	Bare die	N

Table 29. Selection of LCD segment drivers...continued

Type name	Number of elements at MUX							V <sub>DD</sub> (V)	V <sub>LCD</sub> (V)	f <sub>fr</sub> (Hz)	V <sub>LCD</sub> (V) charge pump	V <sub>LCD</sub> (V) temperature compensat.	T <sub>amb</sub> (°C)	Interface	Package	AEC- Q100
	1:1	1:2	1:3	1:4	1:6	1:8	1:9									
PCA85133U	80	160	240	320	-	-	-	1.8 to 5.5	2.5 to 8	82, 110 <sup>[2]</sup>	N	N	-40 to 95	I <sup>2</sup> C	Bare die	Y
PCA85233UG	80	160	240	320	-	-	-	1.8 to 5.5	2.5 to 8	150, 220 <sup>[2]</sup>	N	N	-40 to 105	I <sup>2</sup> C	Bare die	Y
PCF85132U	160	320	480	640	-	-	-	1.8 to 5.5	1.8 to 8	60 to 90 <sup>[1]</sup>	N	N	-40 to 85	I <sup>2</sup> C	Bare die	N
PCA8530DUG	102	204	-	408	-	-	-	2.5 to 5.5	4 to 12	45 to 300 <sup>[1]</sup>	Y	Y	-40 to 105	I <sup>2</sup> C / SPI	Bare die	Y
PCA85132U	160	320	480	640	-	-	-	1.8 to 5.5	1.8 to 8	60 to 90 <sup>[1]</sup>	N	N	-40 to 95	I <sup>2</sup> C	Bare die	Y
PCA85232U	160	320	480	640	-	-	-	1.8 to 5.5	1.8 to 8	117 to 176 <sup>[1]</sup>	N	N	-40 to 95	I <sup>2</sup> C	Bare die	Y
PCF8538UG	102	204	-	408	612	816	918	2.5 to 5.5	4 to 12	45 to 300 <sup>[1]</sup>	Y	Y	-40 to 85	I <sup>2</sup> C / SPI	Bare die	N
PCA8538UG	102	204	-	408	612	816	918	2.5 to 5.5	4 to 12	45 to 300 <sup>[1]</sup>	Y	Y	-40 to 105	I <sup>2</sup> C / SPI	Bare die	Y

[1] Software programmable.

[2] Hardware selectable.

## 21 Abbreviations

Table 30. Abbreviations

Acronym	Description
CDM	Charged-Device Model
CMOS	Complementary Metal-Oxide Semiconductor
HBM	Human Body Model
ITO	Indium Tin Oxide
LCD	Liquid Crystal Display
LSB	Least Significant Bit
MM	Machine Model
MSB	Most Significant Bit
MSL	Moisture Sensitivity Level
PCB	Printed Circuit Board
RAM	Random Access Memory
RMS	Root Mean Square
SCL	Serial CLock line
SDA	Serial DAta line
SMD	Surface Mount Device

## 22 References

- [1] JESD22-A114 Electrostatic Discharge (ESD) Sensitivity Testing Human Body Model (HBM)
- [2] JESD22-A115 Electrostatic Discharge (ESD) Sensitivity Testing Machine Model (MM)
- [3] JESD22-C101 Field-Induced Charged-Device Model Test Method for Electrostatic-Discharge-Withstand Thresholds of Microelectronic Components
- [4] JESD78 IC Latch-Up Test
- [5] SOT364-1\_118 TSSOP56; Reel pack; SMD, 13", packing information
- [6] UM10569 Store and transport requirements

## 23 Revision history

Table 31. Revision history

Document ID	Release date	Data sheet status	Change notice	Supersedes
PCF8576D v.15.1	20210901	Product data sheet	PCN202102010F01	PCF8576D v.15
Modifications:	<ul style="list-style-type: none"> <li>• Updated ordering information. See PCN number in Change notice column.</li> <li>• Updated text and Figures 16, 17, and 18, changing the terms "master" and "slave" to "controller" and "target" to comply with NXP inclusive language policy.</li> </ul>			
PCF8576D v.15	20150212	Product data sheet	-	PCF8576D v.14

Table 31. Revision history...continued

Document ID	Release date	Data sheet status	Change notice	Supersedes
Modifications:	<ul style="list-style-type: none"> <li>The format of this data sheet has been redesigned to comply with the new identity guidelines of NXP Semiconductors.</li> <li>Legal texts have been adapted to the new company name where appropriate.</li> <li>Changed I<sub>DD(LCD)</sub> values in <a href="#">Table 18</a></li> <li>Changed <a href="#">Section 13.1</a> and <a href="#">Section 18.2</a></li> <li>Added <a href="#">Section 20.1</a></li> <li>Fixed typos</li> </ul>			
PCF8576D v.14	20130610	Product data sheet	-	PCF8576D v.13
PCF8576D v.13	20120510	Product data sheet	-	PCF8576D v.12
PCF8576D v.12	20120413	Product data sheet	-	PCF8576D v.11
PCF8576D v.11	20110627	Product data sheet		PCF8576D v.10
PCF8576D v.10	20110214	Product data sheet	-	PCF8576D_9
PCF8576D_9	20090825	Product data sheet	-	PCF8576D_8
PCF8576D_8	20090319	Product data sheet	-	PCF8576D_7
PCF8576D_7	20081218	Product data sheet	-	PCF8576D_6
PCF8576D_6	20081202	Product data sheet	-	PCF8576D_5
PCF8576D_5	20041222	Product specification	-	PCF8576D_4
PCF8576D_4	20041008	Product specification	-	PCF8576D_3
PCF8576D_3	20040617	Product specification	-	PCF8576D_2
PCF8576D_2	20030623	Product specification	-	PCF8576D_1
PCF8576D_1	20030401	Objective specification	-	-

## 24 Legal information

### 24.1 Data sheet status

Document status <sup>[1][2]</sup>	Product status <sup>[3]</sup>	Definition
Objective [short] data sheet	Development	This document contains data from the objective specification for product development.
Preliminary [short] data sheet	Qualification	This document contains data from the preliminary specification.
Product [short] data sheet	Production	This document contains the product specification.

[1] Please consult the most recently issued document before initiating or completing a design.

[2] The term 'short data sheet' is explained in section "Definitions".

[3] The product status of device(s) described in this document may have changed since this document was published and may differ in case of multiple devices. The latest product status information is available on the Internet at URL <http://www.nxp.com>.

### 24.2 Definitions

**Draft** — A draft status on a document indicates that the content is still under internal review and subject to formal approval, which may result in modifications or additions. NXP Semiconductors does not give any representations or warranties as to the accuracy or completeness of information included in a draft version of a document and shall have no liability for the consequences of use of such information.

**Short data sheet** — A short data sheet is an extract from a full data sheet with the same product type number(s) and title. A short data sheet is intended for quick reference only and should not be relied upon to contain detailed and full information. For detailed and full information see the relevant full data sheet, which is available on request via the local NXP Semiconductors sales office. In case of any inconsistency or conflict with the short data sheet, the full data sheet shall prevail.

**Product specification** — The information and data provided in a Product data sheet shall define the specification of the product as agreed between NXP Semiconductors and its customer, unless NXP Semiconductors and customer have explicitly agreed otherwise in writing. In no event however, shall an agreement be valid in which the NXP Semiconductors product is deemed to offer functions and qualities beyond those described in the Product data sheet.

### 24.3 Disclaimers

**Limited warranty and liability** — Information in this document is believed to be accurate and reliable. However, NXP Semiconductors does not give any representations or warranties, expressed or implied, as to the accuracy or completeness of such information and shall have no liability for the consequences of use of such information. NXP Semiconductors takes no responsibility for the content in this document if provided by an information source outside of NXP Semiconductors. In no event shall NXP Semiconductors be liable for any indirect, incidental, punitive, special or consequential damages (including - without limitation - lost profits, lost savings, business interruption, costs related to the removal or replacement of any products or rework charges) whether or not such damages are based on tort (including negligence), warranty, breach of contract or any other legal theory. Notwithstanding any damages that customer might incur for any reason whatsoever, NXP Semiconductors' aggregate and cumulative liability towards customer for the products described herein shall be limited in accordance with the Terms and conditions of commercial sale of NXP Semiconductors.

**Right to make changes** — NXP Semiconductors reserves the right to make changes to information published in this document, including without limitation specifications and product descriptions, at any time and without

notice. This document supersedes and replaces all information supplied prior to the publication hereof.

**Suitability for use** — NXP Semiconductors products are not designed, authorized or warranted to be suitable for use in life support, life-critical or safety-critical systems or equipment, nor in applications where failure or malfunction of an NXP Semiconductors product can reasonably be expected to result in personal injury, death or severe property or environmental damage. NXP Semiconductors and its suppliers accept no liability for inclusion and/or use of NXP Semiconductors products in such equipment or applications and therefore such inclusion and/or use is at the customer's own risk.

**Applications** — Applications that are described herein for any of these products are for illustrative purposes only. NXP Semiconductors makes no representation or warranty that such applications will be suitable for the specified use without further testing or modification. Customers are responsible for the design and operation of their applications and products using NXP Semiconductors products, and NXP Semiconductors accepts no liability for any assistance with applications or customer product design. It is customer's sole responsibility to determine whether the NXP Semiconductors product is suitable and fit for the customer's applications and products planned, as well as for the planned application and use of customer's third party customer(s). Customers should provide appropriate design and operating safeguards to minimize the risks associated with their applications and products. NXP Semiconductors does not accept any liability related to any default, damage, costs or problem which is based on any weakness or default in the customer's applications or products, or the application or use by customer's third party customer(s). Customer is responsible for doing all necessary testing for the customer's applications and products using NXP Semiconductors products in order to avoid a default of the applications and the products or of the application or use by customer's third party customer(s). NXP does not accept any liability in this respect.

**Limiting values** — Stress above one or more limiting values (as defined in the Absolute Maximum Ratings System of IEC 60134) will cause permanent damage to the device. Limiting values are stress ratings only and (proper) operation of the device at these or any other conditions above those given in the Recommended operating conditions section (if present) or the Characteristics sections of this document is not warranted. Constant or repeated exposure to limiting values will permanently and irreversibly affect the quality and reliability of the device.

**Terms and conditions of commercial sale** — NXP Semiconductors products are sold subject to the general terms and conditions of commercial sale, as published at <http://www.nxp.com/profile/terms>, unless otherwise agreed in a valid written individual agreement. In case an individual agreement is concluded only the terms and conditions of the respective agreement shall apply. NXP Semiconductors hereby expressly objects to applying the customer's general terms and conditions with regard to the purchase of NXP Semiconductors products by customer.

**No offer to sell or license** — Nothing in this document may be interpreted or construed as an offer to sell products that is open for acceptance or the grant, conveyance or implication of any license under any copyrights, patents or other industrial or intellectual property rights.

**Bare die** — All die are tested on compliance with their related technical specifications as stated in this data sheet up to the point of wafer sawing and are handled in accordance with the NXP Semiconductors storage and transportation conditions. If there are data sheet limits not guaranteed, these will be separately indicated in the data sheet. There are no post-packing tests performed on individual die or wafers. NXP Semiconductors has no control of third party procedures in the sawing, handling, packing or assembly of the die. Accordingly, NXP Semiconductors assumes no liability for device functionality or performance of the die or systems after third party sawing, handling, packing or assembly of the die. It is the responsibility of the customer to test and qualify their application in which the die is used. All die sales are conditioned upon and subject to the customer entering into a written die sale agreement with NXP Semiconductors through its legal department.

**Export control** — This document as well as the item(s) described herein may be subject to export control regulations. Export might require a prior authorization from competent authorities.

**Non-automotive qualified products** — Unless this data sheet expressly states that this specific NXP Semiconductors product is automotive qualified, the product is not suitable for automotive use. It is neither qualified nor

tested in accordance with automotive testing or application requirements. NXP Semiconductors accepts no liability for inclusion and/or use of non-automotive qualified products in automotive equipment or applications. In the event that customer uses the product for design-in and use in automotive applications to automotive specifications and standards, customer (a) shall use the product without NXP Semiconductors' warranty of the product for such automotive applications, use and specifications, and (b) whenever customer uses the product for automotive applications beyond NXP Semiconductors' specifications such use shall be solely at customer's own risk, and (c) customer fully indemnifies NXP Semiconductors for any liability, damages or failed product claims resulting from customer design and use of the product for automotive applications beyond NXP Semiconductors' standard warranty and NXP Semiconductors' product specifications.

**Translations** — A non-English (translated) version of a document is for reference only. The English version shall prevail in case of any discrepancy between the translated and English versions.

## 24.4 Trademarks

Notice: All referenced brands, product names, service names and trademarks are the property of their respective owners.

**I<sup>2</sup>C-bus** — logo is a trademark of NXP B.V.

**NXP** — wordmark and logo are trademarks of NXP B.V.

Tables

Tab. 1.	Ordering information	2	Tab. 16.	I2C controller address byte	27
Tab. 2.	Ordering options	2	Tab. 17.	Limiting values	30
Tab. 3.	Pin description	5	Tab. 18.	Static characteristics	31
Tab. 4.	Selection of possible display configurations	7	Tab. 19.	Dynamic characteristics	32
Tab. 5.	Biasing characteristics	8	Tab. 20.	Addressing cascaded PCF8576D	34
Tab. 6.	Standard RAM filling in 1:3 multiplex drive mode	20	Tab. 21.	SYNC contact resistance	35
Tab. 7.	Entire RAM filling by rewriting in 1:3 multiplex drive mode	20	Tab. 22.	Dimensions of PCF8576DU/DA	40
Tab. 8.	Blinking frequencies	21	Tab. 23.	Dimensions of PCF8576DU/2DA	40
Tab. 9.	Definition of PCF8576D commands	22	Tab. 24.	Bonding pad location for PCF8576DU/x	40
Tab. 10.	C bit description	22	Tab. 25.	Alignment marks	42
Tab. 11.	Mode-set command bit description	22	Tab. 26.	Description of tray details	43
Tab. 12.	Load-data-pointer command bit description	23	Tab. 27.	SnPb eutectic process (from J-STD-020D)	45
Tab. 13.	Device-select command bit description	23	Tab. 28.	Lead-free process (from J-STD-020D)	46
Tab. 14.	Bank-select command bit description	23	Tab. 29.	Selection of LCD segment drivers	47
Tab. 15.	Blink-select command bit description	24	Tab. 30.	Abbreviations	49
			Tab. 31.	Revision history	49

Figures

Fig. 1.	Block diagram of PCF8576D	3	Fig. 15.	Definition of START and STOP conditions	25
Fig. 2.	Pinning diagram for PCF8576DT (TSSOP56)	4	Fig. 16.	System configuration	25
Fig. 3.	Pinning diagram for PCF8576DU (bare die)	5	Fig. 17.	Acknowledgement of the I2C-bus	26
Fig. 4.	Example of displays suitable for PCF8576D	6	Fig. 18.	I2C-bus protocol	27
Fig. 5.	Typical system configuration	7	Fig. 19.	Format of command byte	28
Fig. 6.	Electro-optical characteristic: relative transmission curve of the liquid	10	Fig. 20.	Device protection circuits	29
Fig. 7.	Static drive mode waveforms	11	Fig. 21.	Driver timing waveforms	33
Fig. 8.	Waveforms for the 1:2 multiplex drive mode with 1/2 bias	12	Fig. 22.	I2C-bus timing waveforms	33
Fig. 9.	Waveforms for the 1:2 multiplex drive mode with 1/3 bias	13	Fig. 23.	Cascaded PCF8576D configuration	35
Fig. 10.	Waveforms for the 1:3 multiplex drive mode with 1/3 bias	14	Fig. 24.	Synchronization of the cascade for the various PCF8576D drive modes	36
Fig. 11.	Waveforms for the 1:4 multiplex drive mode with 1/3 bias	15	Fig. 25.	Package outline SOT364-1 (TSSOP56) of PCF8576DT	37
Fig. 12.	Display RAM bit map	17	Fig. 26.	Bare die outline PCF8576DU/DA (for dimensions see Table 23)	38
Fig. 13.	Relationship between LCD layout, drive mode, display RAM filling order and display data transmitted over the I2C-bus	18	Fig. 27.	Bare die outline PCF8576DU/2DA (for dimensions see Table 24)	39
Fig. 14.	Bit transfer	25	Fig. 28.	Tray details	43
			Fig. 29.	Tray alignment	44
			Fig. 30.	Temperature profiles for large and small components	46

Contents

<b>1</b>	<b>General description</b>	<b>1</b>	<b>16</b>	<b>Bare die outline</b>	<b>38</b>
<b>2</b>	<b>Features and benefits</b>	<b>1</b>	<b>17</b>	<b>Handling information</b>	<b>42</b>
<b>3</b>	<b>Ordering information</b>	<b>2</b>	<b>18</b>	<b>Packing information</b>	<b>43</b>
3.1	Ordering options	2	18.1	Tray information	43
<b>4</b>	<b>Block diagram</b>	<b>3</b>	18.2	Tape and reel information	44
<b>5</b>	<b>Pinning information</b>	<b>4</b>	<b>19</b>	<b>Soldering of SMD packages</b>	<b>44</b>
5.1	Pinning	4	19.1	Introduction to soldering	44
5.2	Pin description	5	19.2	Wave and reflow soldering	44
<b>6</b>	<b>Functional description</b>	<b>6</b>	19.3	Wave soldering	45
6.1	Power-On Reset (POR)	7	19.4	Reflow soldering	45
6.2	LCD bias generator	8	<b>20</b>	<b>Appendix</b>	<b>46</b>
6.3	LCD voltage selector	8	20.1	LCD segment driver selection	46
6.3.1	Electro-optical performance	9	<b>21</b>	<b>Abbreviations</b>	<b>49</b>
6.4	LCD drive mode waveforms	10	<b>22</b>	<b>References</b>	<b>49</b>
6.4.1	Static drive mode	10	<b>23</b>	<b>Revision history</b>	<b>49</b>
6.4.2	1:2 Multiplex drive mode	11	<b>24</b>	<b>Legal information</b>	<b>51</b>
6.4.3	1:3 Multiplex drive mode	13			
6.4.4	1:4 Multiplex drive mode	14			
6.5	Oscillator	15			
6.5.1	Internal clock	16			
6.5.2	External clock	16			
6.6	Timing	16			
6.7	Display register	16			
6.8	Segment outputs	16			
6.9	Backplane outputs	16			
6.10	Display RAM	17			
6.10.1	Data pointer	19			
6.10.2	Subaddress counter	19			
6.10.3	RAM writing in 1:3 multiplex drive mode	20			
6.10.4	Writing over the RAM address boundary	20			
6.10.5	Output bank selector	21			
6.10.6	Input bank selector	21			
6.11	Blinking	21			
6.12	Command decoder	22			
6.13	Display controller	24			
<b>7</b>	<b>Characteristics of the I2C-bus</b>	<b>24</b>			
7.1	Bit transfer	25			
7.2	START and STOP conditions	25			
7.3	System configuration	25			
7.4	Acknowledge	26			
7.5	I2C-bus controller	26			
7.6	Input filters	27			
7.7	I2C-bus protocol	27			
<b>8</b>	<b>Internal circuitry</b>	<b>29</b>			
<b>9</b>	<b>Safety notes</b>	<b>29</b>			
<b>10</b>	<b>Limiting values</b>	<b>30</b>			
<b>11</b>	<b>Static characteristics</b>	<b>31</b>			
<b>12</b>	<b>Dynamic characteristics</b>	<b>32</b>			
<b>13</b>	<b>Application information</b>	<b>34</b>			
13.1	Cascaded operation	34			
<b>14</b>	<b>Test information</b>	<b>36</b>			
14.1	Quality information	36			
<b>15</b>	<b>Package outline</b>	<b>37</b>			

Please be aware that important notices concerning this document and the product(s) described herein, have been included in section 'Legal information'.

## Looking for pricing, stock, or lifecycle information?

Click below to explore more details on WIN SOURCE:

- ⊖ [View PCF8576DU/2DA/2,02 on WIN SOURCE](#)
- ⊖ [NXP / Nexperia Information](#)

## Optimize Your Supply Chain with WIN SOURCE Solutions

- ✓ Global Sourcing Solution
- ✓ Obsolete Management
- ✓ Cost Control Management
- ✓ Shortage Management
- ✓ Alternative Solution
- ✓ Excess Inventory Management