



**THE DATASHEET OF
IDT92HD206XX5PRGXB4X**



8-CHANNEL HIGH DEFINITION AUDIO CODEC

92HD206

Description

The 92HD206 is a Theater Quality 8-channel audio CODEC that enables systems with 7.1 audio or 5.1 audio playing simultaneously with VoIP or another stereo audio stream. IDT's proprietary SD technology provides high fidelity, with a DAC SNR of 95dB.

Features

- **High performance HD Audio CODEC provides Theater Quality Audio**
- **Targeted for designs meeting Premium Windows Logo Program**
- **High performance SD technology**
 - 95dB DAC SNR
 - 90dB ADC SNR
- **Four stereo DACs and two stereo ADCs**
 - Supports 7.1 Audio
 - Supports 5.1 Audio with simultaneous Real Time Communication (RTC) channel such as VoIP or separate stereo audio stream
- **24-bit resolution with up to 192 KHz sample rates**
- **Analog Stereo Microphone**
 - Microphone Boost 0, 10, 20, 30, 40dB
 - Six adjustable Vref outputs for microphone bias
- **Integrated Headphone Amps (3)**
- **S/PDIF In and Out**
- **Volume Up/Down Control**
- **Jack Insertion Detect and Impedance Sensing supports Jack Retasking and Universal Jacks™**
- **Digital PC Beep to all outputs**
- **+5 V Analog Power Supply**
- **Environmental 48-pin LQFP Package**

Software Support

- **SKPI (Kernel Processing Interface)**
 - Enables plug-ins that can operate globally on all audio streams of the system
- **12 band parametric equalizer SKPI plug-in**
 - Constant, system-level effects tuned to optimize a particular platform can be combined with user-mode “presets” tailored for specific acoustical environments and applications
 - System-level effects automatically disabled when external connections made
- **Dynamics Processing SKPI plug-in**
 - Enables improved voice articulation
 - Compressor/limiter allows higher average noise level without resonances
- **Dolby PC Entertainment Experience Logo Program**
 - Dolby Home Theater™
 - Dolby Sound Room™
- **Dolby Technologies**
 - Dolby Headphone™, Dolby Virtual Speaker™
 - Dolby ProLogic II™, Dolby ProLogic IIx™
 - Dolby Digital Live™
- **Intel Audio Studio™ from Sonic Focus**
- **Maxx Player™ from Waves**
- **Microphone Beam Forming, Acoustic Echo Cancellation, & Noise Suppression from Knowles™**

Table of Contents

1. DESCRIPTION	12
2. CHARACTERISTICS	13
2.1. Audio Fidelity	13
2.2. Electrical Specifications	13
2.3. 92HD206 5 V Analog Performance Characteristics	14
3. DETAILED DESCRIPTION	18
3.1. Universal Jacks™	18
3.2. SPDIF Input	19
3.3. SPDIF Output	19
3.4. Headphone Drivers (Restrictions)	20
3.5. Device IDs	20
4. FUNCTIONAL BLOCK DIAGRAMS	21
4.1. 92HD206	21
5. WIDGET DIAGRAM	22
5.1. Pin Configuration Default Register Settings	23
6. WIDGET INFORMATION FOR THE 92HD206 FAMILY	24
6.1. Root Node (NID = 0x00)	26
6.2. AFG Node (NID = 0x01)	27
6.3. DAC0 Node (NID = 0x02)	44
6.4. DAC1 Node (NID = 0x03)	48
6.5. DAC2 Node (NID = 0x04)	53
6.6. DAC3 Node (NID = 0x05)	58
6.7. ADC0 Node (NID = 0x07)	63
6.8. ADC1 Node (NID = 0x08)	68
6.9. SPDIFOut Node (NID = 0x1E)	73
6.10. SPDIFIn Node (NID = 0x20)	78
6.11. PortA Node (NID = 0x0A)	86
6.12. PortB Node (NID = 0x0B)	92
6.13. PortC Node (NID = 0x0C)	98
6.14. PortD Node (NID = 0x0D)	103
6.15. PortE Node (NID = 0x0E)	109
6.16. PortF Node (NID = 0x0F)	114
6.17. PortG Node (NID = 0x10)	119
6.18. PortH Node (NID = 0x11)	124
6.19. DigOut0 Node (NID = 0x21)	129
6.20. InPort0Mux Node (NID = 0x15)	134
6.21. InPort1Mux Node (NID = 0x16)	139
6.22. PCBEEP Node (NID = 0x23)	144
6.23. CD Node (NID = 0x12)	146
6.24. VolumeKnob Node (NID = 0x24)	149
6.25. InPort0Vol Node (NID = 0x18)	153
6.26. InPort1Vol Node (NID = 0x19)	156
6.27. ADC0Mux Node (NID = 0x1B)	158
6.28. ADC1Mux Node (NID = 0x1C)	162
7. ORDERING INFORMATION	167
7.1. 92HD206 Family Options and Part Order Numbers	167
8. PIN INFORMATION	168
8.1. 92HD206 48-Pin LQFP Diagram	168
8.2. Pin Table for 92HD206 in 48 Pin LQFP	168
9. PACKAGE OUTLINE AND PACKAGE DIMENSIONS	171
9.1. 48-Pin LQFP	171
10. SOLDER REFLOW PROFILE	172

10.1. Standard Reflow Profile Data	172
10.2. Pb Free Process - Package Classification Reflow Temperatures	173
11. REVISION HISTORY	174

List of Figures

Figure 1. 92HD206 Functional Block Diagram	21
Figure 2. 92HD206 Widget Diagram	22
Figure 3. 48-Pin LQFP Pinout	168
Figure 4. 48-Pin LQFP Package Outline and Package Dimensions	171
Figure 5. Solder Reflow Profile	172

List of Tables

Table 1. Impedance Sense Levels	19
Table 2. CODEC IDs	20
Table 3. Pin Configuration Default Settings	23
Table 4. High Definition Audio Widget	24
Table 5. Root ID Command Verb Format	26
Table 6. Root ID Command Response Format	26
Table 7. Root RevID Command Verb Format	26
Table 8. Root RevID Command Response Format	26
Table 9. Root NodeInfo Command Verb Format	27
Table 10. Root NodeInfo Command Response Format	27
Table 11. AFG Reset Command Verb Format	27
Table 12. AFG Reset Command Response Format	27
Table 13. AFG NodeInfo Command Verb Format	28
Table 14. AFG NodeInfo Command Response Format	28
Table 15. AFG Type Command Verb Format	28
Table 16. AFG Type Command Response Format	28
Table 17. AFG Cap Command Verb Format	28
Table 18. AFG Cap Command Response Format	29
Table 19. AFG PCMCap Command Verb Format	29
Table 20. AFG PCMCap Command Response Format	29
Table 21. AFG Stream Command Verb Format	30
Table 22. AFG Stream Command Response Format	30
Table 23. AFG InAmpCap Command Verb Format	31
Table 24. AFG InAmpCap Command Response Format	31
Table 25. AFG SupPwrState Command Verb Format	31
Table 26. AFG SupPwrState Command Response Format	31
Table 27. AFG GPIOCnt Command Verb Format	32
Table 28. AFG GPIOCnt Command Response Format	32
Table 29. AFG OutAmpCap Command Verb Format	32
Table 30. AFG OutAmpCap Command Response Format	33
Table 31. AFG PwrState Command Verb Format	33
Table 32. AFG PwrState Command Response Format	33
Table 33. AFG UnsolResp Command Verb Format	34
Table 34. AFG UnsolResp Command Response Format	34
Table 35. AFG GPIO Command Verb Format	34
Table 36. AFG GPIO Command Response Format	34

Table 37. AFG GPIOEn Command Verb Format	35
Table 38. AFG GPIOEn Command Response Format	35
Table 39. AFG GPIODir Command Verb Format	36
Table 40. AFG GPIODir Command Response Format	36
Table 41. AFG GPIOWakeEn Command Verb Format	36
Table 42. AFG GPIOWakeEn Command Response Format	36
Table 43. AFG GPIOUnsol Command Verb Format	37
Table 44. AFG GPIOUnsol Command Response Format	37
Table 45. AFG GPIOSticky Command Verb Format	38
Table 46. AFG GPIOSticky Command Response Format	38
Table 47. AFG SubID Command Verb Format	39
Table 48. AFG SubID Command Response Format	39
Table 49. AFG TCKT Command Verb Format	40
Table 50. AFG TCKT Command Response Format	40
Table 51. AFG Sply Command Verb Format	40
Table 52. AFG Sply Command Response Format	40
Table 53. AFG DACMode Command Verb Format	41
Table 54. AFG DACMode Command Response Format	41
Table 55. AFG GPIOIrty Command Verb Format	41
Table 56. AFG GPIOIrty Command Response Format	41
Table 57. AFG GPIODrive Command Verb Format	42
Table 58. AFG GPIODrive Command Response Format	43
Table 59. AFG DMic Command Verb Format	43
Table 60. AFG DMic Command Response Format	43
Table 61. DAC0 Cnvtr Command Verb Format	44
Table 62. DAC0 Cnvtr Command Response Format	44
Table 63. DAC0 OutAmpRight Command Verb Format	45
Table 64. DAC0 OutAmpRight Command Response Format	45
Table 65. DAC0 OutAmpLeft Command Verb Format	45
Table 66. DAC0 OutAmpLeft Command Response Format	46
Table 67. DAC0 WCap Command Verb Format	46
Table 68. DAC0 WCap Command Response Format	46
Table 69. DAC0 PwrState Command Verb Format	47
Table 70. DAC0 PwrState Command Response Format	47
Table 71. DAC0 CnvtrID Command Verb Format	47
Table 72. DAC0 CnvtrID Command Response Format	48
Table 73. DAC0 LR Command Verb Format	48
Table 74. DAC0 LR Command Response Format	48
Table 75. DAC1 Cnvtr Command Verb Format	48
Table 76. DAC1 Cnvtr Command Response Format	49
Table 77. DAC1 OutAmpRight Command Verb Format	50
Table 78. DAC1 OutAmpRight Command Response Format	50
Table 79. DAC1 OutAmpLeft Command Verb Format	50
Table 80. DAC1 OutAmpLeft Command Response Format	50
Table 81. DAC1 WCap Command Verb Format	50
Table 82. DAC1 WCap Command Response Format	51
Table 83. DAC1 PwrState Command Verb Format	51
Table 84. DAC1 PwrState Command Response Format	52
Table 85. DAC1 CnvtrID Command Verb Format	52
Table 86. DAC1 CnvtrID Command Response Format	52
Table 87. DAC1 LR Command Verb Format	53
Table 88. DAC1 LR Command Response Format	53
Table 89. DAC2 Cnvtr Command Verb Format	53
Table 90. DAC2 Cnvtr Command Response Format	53
Table 91. DAC2 OutAmpRight Command Verb Format	54

Table 92. DAC2 OutAmpRight Command Response Format	55
Table 93. DAC2 OutAmpLeft Command Verb Format	55
Table 94. DAC2 OutAmpLeft Command Response Format	55
Table 95. DAC2 WCap Command Verb Format	55
Table 96. DAC2 WCap Command Response Format	55
Table 97. DAC2 PwrState Command Verb Format	56
Table 98. DAC2 PwrState Command Response Format	56
Table 99. DAC2 CnvtrID Command Verb Format	57
Table 100. DAC2 CnvtrID Command Response Format	57
Table 101. DAC2 LR Command Verb Format	57
Table 102. DAC2 LR Command Response Format	58
Table 103. DAC3 Cnvtr Command Verb Format	58
Table 104. DAC3 Cnvtr Command Response Format	58
Table 105. DAC3 OutAmpRight Command Verb Format	59
Table 106. DAC3 OutAmpRight Command Response Format	59
Table 107. DAC3 OutAmpLeft Command Verb Format	60
Table 108. DAC3 OutAmpLeft Command Response Format	60
Table 109. DAC3 WCap Command Verb Format	60
Table 110. DAC3 WCap Command Response Format	60
Table 111. DAC3 PwrState Command Verb Format	61
Table 112. DAC3 PwrState Command Response Format	61
Table 113. DAC3 CnvtrID Command Verb Format	62
Table 114. DAC3 CnvtrID Command Response Format	62
Table 115. DAC3 LR Command Verb Format	62
Table 116. DAC3 LR Command Response Format	62
Table 117. ADC0 Cnvtr Command Verb Format	63
Table 118. ADC0 Cnvtr Command Response Format	63
Table 119. ADC0 WCap Command Verb Format	64
Table 120. ADC0 WCap Command Response Format	64
Table 121. ADC0 ConLst Command Verb Format	65
Table 122. ADC0 ConLst Command Response Format	65
Table 123. ADC0 ConLstEntry Command Verb Format	65
Table 124. ADC0 ConLstEntry Command Response Format	66
Table 125. ADC0 ProcState Command Verb Format	66
Table 126. ADC0 ProcState Command Response Format	66
Table 127. ADC0 PwrState Command Verb Format	66
Table 128. ADC0 PwrState Command Response Format	67
Table 129. ADC0 CnvtrID Command Verb Format	67
Table 130. ADC0 CnvtrID Command Response Format	67
Table 131. ADC1 Cnvtr Command Verb Format	68
Table 132. ADC1 Cnvtr Command Response Format	68
Table 133. ADC1 WCap Command Verb Format	69
Table 134. ADC1 WCap Command Response Format	69
Table 135. ADC1 ConLst Command Verb Format	70
Table 136. ADC1 ConLst Command Response Format	70
Table 137. ADC1 ConLstEntry Command Verb Format	70
Table 138. ADC1 ConLstEntry Command Response Format	71
Table 139. ADC1 ProcState Command Verb Format	71
Table 140. ADC1 ProcState Command Response Format	71
Table 141. ADC1 PwrState Command Verb Format	71
Table 142. ADC1 PwrState Command Response Format	72
Table 143. ADC1 CnvtrID Command Verb Format	72
Table 144. ADC1 CnvtrID Command Response Format	72
Table 145. SPDIFOut Cnvtr Command Verb Format	73
Table 146. SPDIFOut Cnvtr Command Response Format	73

Table 147. SPDIFOut WCap Command Verb Format	74
Table 148. SPDIFOut WCap Command Response Format	74
Table 149. SPDIFOut PCM Command Verb Format	75
Table 150. SPDIFOut PCM Command Response Format	75
Table 151. SPDIFOut Stream Command Verb Format	76
Table 152. SPDIFOut Stream Command Response Format	76
Table 153. SPDIFOut CnvtrID Command Verb Format	77
Table 154. SPDIFOut CnvtrID Command Response Format	77
Table 155. SPDIFOut DigCnvtr Command Verb Format	77
Table 156. SPDIFOut DigCnvtr Command Response Format	77
Table 157. SPDIFIn Cnvtr Command Verb Format	78
Table 158. SPDIFIn Cnvtr Command Response Format	78
Table 159. SPDIFIn WCap Command Verb Format	79
Table 160. SPDIFIn WCap Command Response Format	79
Table 161. SPDIFIn PCMCap Command Verb Format	80
Table 162. SPDIFIn PCMCap Command Response Format	80
Table 163. SPDIFIn Stream Command Verb Format	81
Table 164. SPDIFIn Stream Command Response Format	81
Table 165. SPDIFIn ConLst Command Verb Format	82
Table 166. SPDIFIn ConLst Command Response Format	82
Table 167. SPDIFIn ConLstEntry Command Verb Format	82
Table 168. SPDIFIn ConLstEntry Command Response Format	82
Table 169. SPDIFIn CnvtrID Command Verb Format	83
Table 170. SPDIFIn CnvtrID Command Response Format	83
Table 171. SPDIFIn DigCnvtr Command Verb Format	83
Table 172. SPDIFIn DigCnvtr Command Response Format	83
Table 173. SPDIFIn VCSR0 Command Verb Format	84
Table 174. SPDIFIn VCSR0 Command Response Format	84
Table 175. PortA WCap Command Verb Format	86
Table 176. PortA WCap Command Response Format	86
Table 177. PortA PinCap Command Verb Format	87
Table 178. PortA PinCap Command Response Format	87
Table 179. PortA ConLst Command Verb Format	88
Table 180. PortA ConLst Command Response Format	88
Table 181. PortA ConLstEntry Command Verb Format	89
Table 182. PortA ConLstEntry Command Response Format	89
Table 183. PortA ConSelectCtrl Command Verb Format	89
Table 184. PortA ConSelectCtrl Command Response Format	89
Table 185. PortA PinWCntrl Command Verb Format	89
Table 186. PortA PinWCntrl Command Response Format	90
Table 187. PortA UnsolResp Command Verb Format	90
Table 188. PortA UnsolResp Command Response Format	90
Table 189. PortA ChSense Command Verb Format	91
Table 190. PortA ChSense Command Response Format	91
Table 191. PortA ConfigDefault Command Verb Format	91
Table 192. PortA ConfigDefault Command Response Format	92
Table 193. PortB WCap Command Verb Format	92
Table 194. PortB WCap Command Response Format	92
Table 195. PortB PinCap Command Verb Format	93
Table 196. PortB PinCap Command Response Format	93
Table 197. PortB ConLst Command Verb Format	94
Table 198. PortB ConLst Command Response Format	94
Table 199. PortB ConLstEntry Command Verb Format	94
Table 200. PortB ConLstEntry Command Response Format	94
Table 201. PortB ConSelectCtrl Command Verb Format	95

Table 202. PortB ConSelectCtrl Command Response Format	95
Table 203. PortB PinWCntrl Command Verb Format	95
Table 204. PortB PinWCntrl Command Response Format	95
Table 205. PortB UnsolResp Command Verb Format	96
Table 206. PortB UnsolResp Command Response Format	96
Table 207. PortB ChSense Command Verb Format	97
Table 208. PortB ChSense Command Response Format	97
Table 209. PortB ConfigDefault Command Verb Format	97
Table 210. PortB ConfigDefault Command Response Format	98
Table 211. PortC WCap Command Verb Format	98
Table 212. PortC WCap Command Response Format	98
Table 213. PortC PinCap Command Verb Format	99
Table 214. PortC PinCap Command Response Format	99
Table 215. PortC ConLst Command Verb Format	100
Table 216. PortC ConLst Command Response Format	100
Table 217. PortC ConLstEntry Command Verb Format	100
Table 218. PortC ConLstEntry Command Response Format	100
Table 219. PortC PinWCntrl Command Verb Format	101
Table 220. PortC PinWCntrl Command Response Format	101
Table 221. PortC UnsolResp Command Verb Format	101
Table 222. PortC UnsolResp Command Response Format	102
Table 223. PortC ChSense Command Verb Format	102
Table 224. PortC ChSense Command Response Format	102
Table 225. PortC ConfigDefault Command Verb Format	103
Table 226. PortC ConfigDefault Command Response Format	103
Table 227. PortD WCap Command Verb Format	103
Table 228. PortD WCap Command Response Format	103
Table 229. PortD PinCap Command Verb Format	104
Table 230. PortD PinCap Command Response Format	104
Table 231. PortD ConLst Command Verb Format	105
Table 232. PortD ConLst Command Response Format	105
Table 233. PortD ConLstEntry Command Verb Format	106
Table 234. PortD ConLstEntry Command Response Format	106
Table 235. PortD PinWCntrl Command Verb Format	106
Table 236. PortD PinWCntrl Command Response Format	106
Table 237. PortD UnsolResp Command Verb Format	107
Table 238. PortD UnsolResp Command Response Format	107
Table 239. PortD ChSense Command Verb Format	107
Table 240. PortD ChSense Command Response Format	108
Table 241. PortD ConfigDefault Command Verb Format	108
Table 242. PortD ConfigDefault Command Response Format	108
Table 243. PortE WCap Command Verb Format	109
Table 244. PortE WCap Command Response Format	109
Table 245. PortE PinCap Command Verb Format	110
Table 246. PortE PinCap Command Response Format	110
Table 247. PortE ConLst Command Verb Format	110
Table 248. PortE ConLst Command Response Format	111
Table 249. PortE ConLstEntry Command Verb Format	111
Table 250. PortE ConLstEntry Command Response Format	111
Table 251. PortE PinWCntrl Command Verb Format	111
Table 252. PortE PinWCntrl Command Response Format	111
Table 253. PortE UnsolResp Command Verb Format	112
Table 254. PortE UnsolResp Command Response Format	112
Table 255. PortE ChSense Command Verb Format	112
Table 256. PortE ChSense Command Response Format	113

Table 257. PortE ConfigDefault Command Verb Format	113
Table 258. PortE ConfigDefault Command Response Format	114
Table 259. PortF WCap Command Verb Format	114
Table 260. PortF WCap Command Response Format	114
Table 261. PortF PinCap Command Verb Format	115
Table 262. PortF PinCap Command Response Format	115
Table 263. PortF ConLst Command Verb Format	116
Table 264. PortF ConLst Command Response Format	116
Table 265. PortF ConLstEntry Command Verb Format	116
Table 266. PortF ConLstEntry Command Response Format	116
Table 267. PortF PinWCntrl Command Verb Format	117
Table 268. PortF PinWCntrl Command Response Format	117
Table 269. PortF UnsolResp Command Verb Format	117
Table 270. PortF UnsolResp Command Response Format	118
Table 271. PortF ChSense Command Verb Format	118
Table 272. PortF ChSense Command Response Format	118
Table 273. PortF ConfigDefault Command Verb Format	119
Table 274. PortF ConfigDefault Command Response Format	119
Table 275. PortG WCap Command Verb Format	119
Table 276. PortG WCap Command Response Format	119
Table 277. PortG PinCap Command Verb Format	120
Table 278. PortG PinCap Command Response Format	120
Table 279. PortG ConLst Command Verb Format	121
Table 280. PortG ConLst Command Response Format	121
Table 281. PortG ConLstEntry Command Verb Format	121
Table 282. PortG ConLstEntry Command Response Format	122
Table 283. PortG PinWCntrl Command Verb Format	122
Table 284. PortG PinWCntrl Command Response Format	122
Table 285. PortG UnsolResp Command Verb Format	122
Table 286. PortG UnsolResp Command Response Format	123
Table 287. PortG ChSense Command Verb Format	123
Table 288. PortG ChSense Command Response Format	123
Table 289. PortG ConfigDefault Command Verb Format	124
Table 290. PortG ConfigDefault Command Response Format	124
Table 291. PortH WCap Command Verb Format	124
Table 292. PortH WCap Command Response Format	124
Table 293. PortH PinCap Command Verb Format	125
Table 294. PortH PinCap Command Response Format	125
Table 295. PortH ConLst Command Verb Format	126
Table 296. PortH ConLst Command Response Format	126
Table 297. PortH ConLstEntry Command Verb Format	126
Table 298. PortH ConLstEntry Command Response Format	127
Table 299. PortH PinWCntrl Command Verb Format	127
Table 300. PortH PinWCntrl Command Response Format	127
Table 301. PortH UnsolResp Command Verb Format	127
Table 302. PortH UnsolResp Command Response Format	128
Table 303. PortH ChSense Command Verb Format	128
Table 304. PortH ChSense Command Response Format	128
Table 305. PortH ConfigDefault Command Verb Format	129
Table 306. PortH ConfigDefault Command Response Format	129
Table 307. DigOut0 WCap Command Verb Format	129
Table 308. DigOut0 WCap Command Response Format	129
Table 309. DigOut0 PinCap Command Verb Format	130
Table 310. DigOut0 PinCap Command Response Format	130
Table 311. DigOut0 ConLst Command Verb Format	131

Table 312. DigOut0 ConLst Command Response Format	131
Table 313. DigOut0 ConLstEntry0 Command Verb Format	131
Table 314. DigOut0 ConLstEntry0 Command Response Format	132
Table 315. DigOut0 ConLstEntry4 Command Verb Format	132
Table 316. DigOut0 ConLstEntry4 Command Response Format	132
Table 317. DigOut0 ConSelectCtrl Command Verb Format	132
Table 318. DigOut0 ConSelectCtrl Command Response Format	133
Table 319. DigOut0 PinWCntrl Command Verb Format	133
Table 320. DigOut0 PinWCntrl Command Response Format	133
Table 321. DigOut0 ConfigDefault Command Verb Format	133
Table 322. DigOut0 ConfigDefault Command Response Format	134
Table 323. InPort0Mux WCap Command Verb Format	134
Table 324. InPort0Mux WCap Command Response Format	134
Table 325. InPort0Mux ConLst Command Verb Format	135
Table 326. InPort0Mux ConLst Command Response Format	135
Table 327. InPort0Mux OutAmpCap Command Verb Format	135
Table 328. InPort0Mux OutAmpCap Command Response Format	136
Table 329. InPort0Mux OutAmpRight Command Verb Format	136
Table 330. InPort0Mux OutAmpRight Command Response Format	136
Table 331. InPort0Mux OutAmpLeft Command Verb Format	137
Table 332. InPort0Mux OutAmpLeft Command Response Format	137
Table 333. InPort0Mux ConSelectCtrl Command Verb Format	137
Table 334. InPort0Mux ConSelectCtrl Command Response Format	137
Table 335. InPort0Mux ConLstEntry0 Command Verb Format	137
Table 336. InPort0Mux ConLstEntry0 Command Response Format	138
Table 337. InPort0Mux ConLstEntry4 Command Verb Format	138
Table 338. InPort0Mux ConLstEntry4 Command Response Format	138
Table 339. InPort0Mux ConLstEntry8 Command Verb Format	138
Table 340. InPort0Mux ConLstEntry8 Command Response Format	138
Table 341. InPort1Mux WCap Command Verb Format	139
Table 342. InPort1Mux WCap Command Response Format	139
Table 343. InPort1Mux ConLst Command Verb Format	140
Table 344. InPort1Mux ConLst Command Response Format	140
Table 345. InPort1Mux OutAmpCap Command Verb Format	140
Table 346. InPort1Mux OutAmpCap Command Response Format	140
Table 347. InPort1Mux OutAmpRight Command Verb Format	141
Table 348. InPort1Mux OutAmpRight Command Response Format	141
Table 349. InPort1Mux OutAmpLeft Command Verb Format	141
Table 350. InPort1Mux OutAmpLeft Command Response Format	142
Table 351. InPort1Mux ConSelectCtrl Command Verb Format	142
Table 352. InPort1Mux ConSelectCtrl Command Response Format	142
Table 353. InPort1Mux ConLstEntry0 Command Verb Format	142
Table 354. InPort1Mux ConLstEntry0 Command Response Format	142
Table 355. InPort1Mux ConLstEntry4 Command Verb Format	143
Table 356. InPort1Mux ConLstEntry4 Command Response Format	143
Table 357. InPort1Mux ConLstEntry8 Command Verb Format	143
Table 358. InPort1Mux ConLstEntry8 Command Response Format	143
Table 359. PCBEEP OutAmpLeft Command Verb Format	144
Table 360. PCBEEP OutAmpLeft Command Response Format	144
Table 361. PCBEEP WCap Command Verb Format	144
Table 362. PCBEEP WCap Command Response Format	144
Table 363. PCBEEP OutAmpCap Command Verb Format	145
Table 364. PCBEEP OutAmpCap Command Response Format	145
Table 365. PCBEEP Gen Command Verb Format	145
Table 366. PCBEEP Gen Command Response Format	146

Table 367. CD WCap Command Verb Format	146
Table 368. CD WCap Command Response Format	146
Table 369. CD PinCap Command Verb Format	147
Table 370. CD PinCap Command Response Format	147
Table 371. CD PinWCntrl Command Verb Format	148
Table 372. CD PinWCntrl Command Response Format	148
Table 373. CD ConfigDefault Command Verb Format	148
Table 374. CD ConfigDefault Command Response Format	149
Table 375. VolumeKnob WCap Command Verb Format	149
Table 376. VolumeKnob WCap Command Response Format	149
Table 377. VolumeKnob VolKnobCap Command Verb Format	150
Table 378. VolumeKnob VolKnobCap Command Response Format	150
Table 379. VolumeKnob ConLst Command Verb Format	150
Table 380. VolumeKnob ConLst Command Response Format	150
Table 381. VolumeKnob ConLstEntry0 Command Verb Format	150
Table 382. VolumeKnob ConLstEntry0 Command Response Format	151
Table 383. VolumeKnob ConLstEntry4 Command Verb Format	151
Table 384. VolumeKnob ConLstEntry4 Command Response Format	151
Table 385. VolumeKnob UnsolResp Command Verb Format	151
Table 386. VolumeKnob UnsolResp Command Response Format	152
Table 387. VolumeKnob Cntrl Command Verb Format	152
Table 388. VolumeKnob Cntrl Command Response Format	152
Table 389. VolumeKnob VCSR0 Command Verb Format	152
Table 390. VolumeKnob VCSR0 Command Response Format	153
Table 391. InPort0Vol WCap Command Verb Format	153
Table 392. InPort0Vol WCap Command Response Format	153
Table 393. InPort0Vol ConLst Command Verb Format	154
Table 394. InPort0Vol ConLst Command Response Format	154
Table 395. InPort0Vol InAmpRight Command Verb Format	154
Table 396. InPort0Vol InAmpRight Command Response Format	155
Table 397. InPort0Vol InAmpLeft Command Verb Format	155
Table 398. InPort0Vol InAmpLeft Command Response Format	155
Table 399. InPort0Vol ConLstEntry Command Verb Format	155
Table 400. InPort0Vol ConLstEntry Command Response Format	155
Table 401. InPort1Vol WCap Command Verb Format	156
Table 402. InPort1Vol WCap Command Response Format	156
Table 403. InPort1Vol ConLst Command Verb Format	157
Table 404. InPort1Vol ConLst Command Response Format	157
Table 405. InPort1Vol InAmpRight Command Verb Format	157
Table 406. InPort1Vol InAmpRight Command Response Format	157
Table 407. InPort1Vol InAmpLeft Command Verb Format	157
Table 408. InPort1Vol InAmpLeft Command Response Format	158
Table 409. InPort1Vol ConLstEntry Command Verb Format	158
Table 410. InPort1Vol ConLstEntry Command Response Format	158
Table 411. ADC0Mux WCap Command Verb Format	158
Table 412. ADC0Mux WCap Command Response Format	158
Table 413. ADC0Mux ConLst Command Verb Format	159
Table 414. ADC0Mux ConLst Command Response Format	159
Table 415. ADC0Mux ConSelectCtrl Command Verb Format	160
Table 416. ADC0Mux ConSelectCtrl Command Response Format	160
Table 417. ADC0Mux ConLstEntry Command Verb Format	160
Table 418. ADC0Mux ConLstEntry Command Response Format	160
Table 419. ADC0Mux LR Command Verb Format	161
Table 420. ADC0Mux LR Command Response Format	161
Table 421. ADC0Mux OutAmpCap Command Verb Format	161
Table 422. ADC0Mux OutAmpCap Command Response Format	161
Table 423. ADC0Mux OutAmpRight Command Verb Format	162
Table 424. ADC0Mux OutAmpRight Command Response Format	162

Table 425. ADC0Mux OutAmpLeft Command Verb Format	162
Table 426. ADC0Mux OutAmpLeft Command Response Format	162
Table 427. ADC1Mux WCap Command Verb Format	162
Table 428. ADC1Mux WCap Command Response Format	163
Table 429. ADC1Mux ConLst Command Verb Format	163
Table 430. ADC1Mux ConLst Command Response Format	164
Table 431. ADC1Mux ConSelectCtrl Command Verb Format	164
Table 432. ADC1Mux ConSelectCtrl Command Response Format	164
Table 433. ADC1Mux ConLstEntry Command Verb Format	164
Table 434. ADC1Mux ConLstEntry Command Response Format	164
Table 435. ADC1Mux LR Command Verb Format	165
Table 436. ADC1Mux LR Command Response Format	165
Table 437. ADC1Mux OutAmpCap Command Verb Format	165
Table 438. ADC1Mux OutAmpCap Command Response Format	165
Table 439. ADC1Mux OutAmpRight Command Verb Format	166
Table 440. ADC1Mux OutAmpRight Command Response Format	166
Table 441. ADC1Mux OutAmpLeft Command Verb Format	166
Table 442. ADC1Mux OutAmpLeft Command Response Format	166

1. DESCRIPTION

The 92HD206 is a high fidelity, 8-channel audio CODEC compatible with the Intel High Definition (HD) Audio Interface. The 92HD206 CODEC provides high quality HD Audio capability to notebook and cost sensitive desktop PC applications.

The 92HD206 incorporates IDT's proprietary technology to achieve a DAC SNR of 95dB. The higher performance and quality of IDT's audio solutions brings consumer electronics level performance to the notebook, desktop and media center PC.

The 92HD206 provides stereo, 24-bit, full duplex resolution, supporting sample rates up to 192 KHz by the DAC and ADC. The SPDIF In/Out supports sample rates of 96 KHz, 48 KHz and 44.1 KHz plus SPDIF OUT supports 88.2 KHz. Additional sample rates are supported by the driver software.

The 92HD206 supports all desired eight channel configurations, including switchable Headphone Out, and Universal Jacks™ functionality for jack detection and re-tasking. The SPDIF interface provides connectivity to Consumer Electronic equipment like Dolby Digital decoders, powered speakers, mini disk drives or a home entertainment systems. All analog I/O pairs support LINE_IN, LINE_OUT and MIC.

MIC inputs can be programmed with 0/10/20/30/40dB boost. For more advanced configurations, the 92HD206 has up to three General Purpose I/O (GPIO) pins. The 92HD206 also provides a single ended CD input for compatibility with DRM solutions and to support legacy OS issues.

The 92HD206 integrates a headphone amplifier on Ports A, B and D. The headphone amplifier is dedicated to these three outputs for increased flexibility, enhanced user experience, and reduced implementation costs.

The Universal Jack™ feature allows the CODEC to detect when audio devices are plugged in, and for the CODEC to be reconfigured to support these devices regardless of which port they are plugged into. SPDIF input sensing is also supported. The fully parametric IDT SoftEQ can be initiated/disabled upon headphone jack insertion/removal for protection of notebook speakers. Note: The Jack Detect circuit and component selection are critical for accurate detection of audio jacks on individual ports. Please see the IDT 92HD206 reference design for circuit implementation details.

The 92HD206 operates with a 3.3 V digital supply and a 5 V analog supply.

The 92HD206 is available in 48-pin LQFP Environmental (ROHS) packages.

2. CHARACTERISTICS

2.1. Audio Fidelity

DAC SNR:	95dB	A-Weighted	5.0 V +/- 5%
ADC SNR:	90dB	A-Weighted	5.0 V +/- 5%

2.2. Electrical Specifications

2.2.1. Absolute Maximum Ratings

Stresses above the ratings listed below can cause permanent damage to the 92HD206. These ratings, which are standard values for IDT commercially rated parts, are stress ratings only. Functional operation of the device at these or any other conditions above those indicated in the operational sections of the specifications is not implied. Exposure to absolute maximum rating conditions for extended periods can affect product reliability. Electrical parameters are guaranteed only over the recommended operating temperature range.

Item	Pin	Maximum Rating
Analog maximum supply voltage	AVdd	6 Volts
Digital maximum supply voltage	DVdd	5.5 Volts
VREFOUT output current		5 mA
Voltage on any pin relative to ground		Vss - 0.3 V to Vdd + 0.3 V
Operating temperature		0°C to +70°C
Storage temperature		-55 °C to +125 °C
Soldering temperature		260 °C for 10 seconds Soldering temperature information for all available packages begins on page 173.

2.2.2. Recommended Operation Conditions

Parameter		Min.	Typ.	Max.	Units
Power Supply Voltage	Digital - 3.3 V	3.135	3.3	3.465	V
	Analog - 5 V	4.75	5	5.25	V
Ambient Operating Temperature		0		+70	°C
Case Temperature	T _{case} (48-LQFP)			+90	°C

ESD: The 92HD206 is an ESD (electrostatic discharge) sensitive device. The human body and test equipment can accumulate and discharge electrostatic charges up to 4000 Volts without detection. Even though the 92HD206 implements internal ESD protection circuitry, proper ESD precautions should be followed to avoid damaging the functionality or performance.

2.3. 92HD206 5 V Analog Performance Characteristics

($T_{\text{ambient}} = 25\text{ }^{\circ}\text{C}$, $AV_{\text{dd}} = 5\text{ V} \pm 5\%$, $DV_{\text{dd}} = 3.3\text{ V} \pm 5\%$, $AV_{\text{ss}} = DV_{\text{ss}} = 0\text{ V}$; 1 KHz input sine wave; Sample Frequency = 48 KHz; 0dB = 1 VRMS, 10 KW / 50 pF load, Testbench Characterization BW: 20 Hz – 20 KHz, 0dB settings on all gain stages)

Parameter	Conditions	AVdd	Min	Typ	Max	Unit
Digital to Analog Converters						
Resolution		5 V		24		Bits
SNR - DAC to All Line-Out Ports (Note 4)	Analog Mixer Disabled, PCM data	5 V		95		dB
THD+N - DAC to All Line-Out Ports (Note 3)	Analog Mixer Disabled, -3dB Signal, PCM data	5 V		90		dB
SNR - DAC to All Line-Out Ports (Note 4)	Analog Mixer Enabled, PCM data	5 V		90		dB
THD+N - DAC to All Line-Out Ports (Note 3)	Analog Mixer Enabled, -3dB Signal, PCM data	5 V		80		dB
Dynamic Range: DAC to All Line Out Ports (Note2)	-60dB Signal Level	5 V	-	93	-	dB
SNR - DAC to All Headphone Ports (Note 4)	Analog Mixer Disabled, 10 K Ω load, PCM data	5 V		95		dB
THD+N - DAC to All Headphone Ports (Note 3)	Analog Mixer Disabled, -3dB Signal, 10 K Ω load, PCM data	5 V		85		dB
SNR - DAC to All Headphone Ports (Note 4)	Analog Mixer Disabled, 32 Ω load, PCM data	5 V		95		dB
THD+N - DAC to All Headphone Ports (Note 3)	Analog Mixer Disabled, -3dB Signal, 32 Ω load, PCM data	5 V		85		dB
SNR - DAC to All Headphone Ports (Note 4)	Analog Mixer Enabled, 10 k Ω load, PCM data	5 V		90		dB
THD+N - DAC to All Headphone Ports (Note 3)	Analog Mixer Enabled, -3dB Signal, 10 k Ω load, PCM data	5 V		79		dB
SNR - DAC to All Headphone Ports (Note 4)	Analog Mixer Enabled, 32 Ω load, PCM data	5 V		87		dB
THD+N - DAC to All Headphone Ports (Note 3)	Analog Mixer Enabled, -3dB Signal, 32 Ω load, PCM data	5 V		74		dB
Any Analog Input to DAC Crosstalk	10 KHz Signal Frequency	5 V	-	-85	-	dB
Any Analog Input to DAC Crosstalk	1 KHz Signal Frequency	5 V	-	-80	-	dB
Gain Error	Analog Mixer Disabled	5 V			0.5	dB
Interchannel Gain Mismatch	Analog Mixer Disabled	5 V			0.5	dB
D/A Digital Filter Pass Band (Note 5)		5 V	20	-	19,200	Hz
D/A Digital Filter Transition Band		5 V	19,200	-	28,800	Hz
D/A Digital Filter Stop Band		5 V	28,800	-	-	Hz
D/A Digital Filter Stop Band Rejcn (Note 6)		5 V	-100	-	-	dB
D/A Out-of-Band Rejection (Note 7)		5 V	-55	-	-	dB

Parameter	Conditions	AVdd	Min	Typ	Max	Unit
Group Delay (48 KHz sample rate)		5 V	-	-	1	ms
Attenuation, Gain Step Size DIGITAL		5 V	-	0.75	-	dB
Gain Drift		5 V	-	100	-	ppm/°C
DAC Offset Voltage		5 V	-	100	20	mV
Deviation from Linear Phase		5 V	-	1	10	deg.
Analog Outputs						
Full Scale All Line-Outs	DAC PCM Data	5 V	1.00	-	-	Vrms
Full Scale All Line-Outs	DAC PCM Data	5 V	2.83	-	-	Vp-p
All Headphone Capable Outputs (peak)	32 Ω load	5 V	31	50	-	mW
Analog inputs						
Full Scale Input Voltage	0dB Boost @ 4.75 V	5 V	1.00	-	-	Vrms
All Analog Inputs with boost	10dB Boost	5 V	0.31	-	-	Vrms
All Analog Inputs with boost	20dB Boost	5 V	0.10	-	-	Vrms
All Analog Inputs with boost	30dB Boost	5 V	0.03	-	-	Vrms
All Analog Inputs with boost	40dB Boost	5 V	0.01	-	-	Vrms
Input Impedance		5 V	-	50	-	K Ω
Input Capacitance		5 V	-	15	-	pF
Analog Mixer						
SNR - CD to Ports A,B, & D Line-Out (Note 4)		5 V		90		dB
THD+N - CD to Ports A,B, & D Line-Out (Note 3)	-3dB Input	5 V		70		dB
SNR - All Line-In to A,B, & D Line-Out (Note 4)		5 V		90		dB
THD+N - All Line-In to A,B, & D Line-Out (Note 3)	-3dB Input	5 V		70		dB
SNR - Analog PC Beep to Ports A, B, & D Line-Out (Note 4)		5 V		85		dB
THD+N - Analog PC Beep to Ports A, B, & D Line-Out (Note 3)	-3dB Input	5 V		70		dB
Analog to Digital Converter						
Resolution		5 V		24		Bits
Dynamic Range, All Analog Inputs to A/D (Note 1)	High Pass Filter Enabled, 1 Vrms Input, No boost	5 V	88	90		dB
SNR All Analog Inputs to A/D (Note 4)	High Pass Filter enabled	5 V	88	90		dB
THD+N All Analog Inputs to A/D (Note 3)	High Pass Filter enabled, -3dBV input Level	5 V		85		dB
Analog Frequency Response (Note 2)		5 V	10	-	30,000	Hz
A/D Digital Filter Pass Band (Note 5)		5 V	20	-	19,200	Hz
A/D Digital Filter Transition Band		5 V	19,200	-	28,800	Hz

Parameter	Conditions	AVdd	Min	Typ	Max	Unit
A/D Digital Filter Stop Band		5 V	28,800	-	-	Hz
A/D Digital Filter Stop Band Rejection (Note 6)		5 V	-100	-	-	dB
Group Delay (48 KHz sample rate)		5 V	-	-	1	ms
Any Analog Input to ADC Crosstalk	10 KHz Signal Frequency	5 V	-	-85	-	dB
Any Analog Input to ADC Crosstalk	1 KHz Signal Frequency	5 V	-	-80	-	dB
Spurious Tone Rejection		5 V	-	-100	-	dB
Attenuation, Gain Step Size ANALOG		5 V	-	1.5	-	dB
Interchannel Gain Mismatch ADC		5 V	-	-	0.5	dB
Noise Floor when 40dB Mic Boost Enabled		5 V			0.01	mV
40dB Mic Boost Enabled SNR	5 mV Input	5 V		60		dB
40dB Mic Boost Enabled THD+N	5 mV Input	5 V		55		dB
Power Supply						
Power Supply Rejection Ratio	1 KHz	5 V	-	-70	-	dB
Power Supply Rejection Ratio	20 KHz	5 V	-	-40	-	dB
D0 Didd		5 V		75	90	mA
D0 Aidd		5 V		85		mA
D1 Didd		5 V		75	90	mA
D1 Aidd		5 V		85		mA
D2 Didd		5 V		23	30	mA
D2 Aidd		5 V		58		mA
D3 Didd		5 V		23	30	mA
D3 Aidd		5 V		37		mA
One Stereo ADC Didd		5 V		8	10	mA
One Stereo ADC Aidd		5 V		10		mA
One Stereo DAC Didd		5 V		3	5	mA
One Stereo DAC Aidd		5 V		2		mA
CD Input						
CD Common Mode Rejection (CMR)		All	50	55		dB
Voltage Reference Outputs						
VREFout (Note 8)		All	-	0.5 X AVdd	-	V
VREFILT (VAG)		5 V		0.45 X AVdd		V
Phased Locked Loop						
PLL lock time		5 V		96	200	μsec
PLL (HD Bit CLK) 24 MHz clock jitter		5 V		150	500	psec

- Ratio of Full Scale signal to noise output with -60dB signal, measured "A weighted" over a 20 Hz to a 20 KHz bandwidth.
- ± 3dB limits for Line Output and 0dB gain, at -20dBV

3. Amplitude of THD+N, measured with A-weighting filter, over 20 Hz to 20 KHz bandwidth.
4. Ratio of Full Scale signal to idle channel noise output is measured "A weighted" over a 20 Hz to a 20 KHz bandwidth. (AES17-1991 Idle Channel Noise or EIAJ CP-307 Signal-to-noise Ratio.)
5. Peak-to-Peak Ripple over Passband meets $\pm 0.25\text{dB}$ limits, 48 KHz Sample Frequency.
6. Stop Band rejection determines filter requirements. Out-of-Band rejection determines audible noise.
7. The integrated Out-of-Band noise generated by the DAC process, during normal PCM audio playback, over a bandwidth 28.8 KHz to 100 KHz, with respect to a 1 Vrms DAC output.
8. Can be set to 0.5 or 0.8 AVdd.

3. DETAILED DESCRIPTION

3.1. Universal Jacks™

IDT's Universal Jacks technology allows for the greatest flexibility in board design and implementation.

For the 92HD206 family the Universal Jacks capabilities are as follows¹:

- Ports A, B, and D support²:
 - Headphone Out
 - Line Out
 - Line In
 - Mic with 0/10/20/30/40 dB Mic boost³
- Ports C, E, F, G, H support²:
 - Line Out
 - Line In
 - Mic with 0/10/20/30/40 dB Mic boost³
 - Ports G & H do not have VrefOut Support

Note¹: On the 92HD206 family, only one function can be selected on each pin pair at a time. For example, a pin pair cannot be configured as an input and output at the same time. Configuration can be changed at any time.

Note²: Three headphones should not be used simultaneously. Performance degradation will occur when using two headphones simultaneously. See electrical specs for details.

Note³: When the 40dB microphone boost feature is enabled, additional gain increases greater than 6dB may result in significant audio quality degradation of the microphone audio input. In particular, when the 40dB microphone boost is active, the SNR, THD+N and DC offset will significantly degrade regardless of the input signal level.

3.1.1. Audio Jack Presence Detect

SENSE_A pin is used to detect the presence of plugs in ports A, B, C, and D. SENSE_B pin is used to detect the presence of plugs in ports E, F, G, and H. Refer to the reference design for details of the port detect circuitry.

Impedance Sense is accomplished by on-chip circuitry that measures the impedance at the pin of the chip and compares it to internal reference impedance bins. Below, is a table that contains the bin information and codes returned when the pin widget impedance field in the Port Pin Sense widget is read. Please note that even under the best conditions, there is no method to guarantee 100% impedance sensing due to variations in external circuitry and impedance overlap of devices that can be plugged into a jack. The impedance sense table reflects both standard Line Out and Headphone output drivers. Please reference the HD Audio Universal Jack Application Note on the IDT Extranet for more information.

Table 1. Impedance Sense Levels

Bins	Return Hex Code	Impedance Level (Ohms)	General Device Detected
000b	0064h	Impedance < 300	Passive Speakers, Headset Speakers
001b	012Ch	Impedance = 300 +/- 25%	Some Headset Speakers
010b	028Ah	300 > Impedance < 1275	Some Microphones
011b	03E8h	Impedance = 1275 +/- 25%	Microphones
100b	07D0h	1275 > Impedance < 2000	Microphones
101b	0BB8h	Impedance = 2000 +/- 25%	Amplified Speakers
110b	2710h	> 2000	Amplified Speakers, Line In
111b	2710h	> 2000	Amplified Speakers, Line In

3.2. SPDIF Input

SPDIF_IN can operate at 44.1 KHz, 48 KHz or 96 KHz and implements internal Jack Detect.

A sophisticated digital PLL allows automatic rate detection and accurate data recovery. The ability to directly accept consumer SPDIF voltage levels eliminates the need for costly external receiver ICs. Advanced features such as record slot select and SPDIF_IN routing to the DAC allows for simultaneous record and play.

3.3. SPDIF Output

SPDIF Output can operate at 44.1 KHz, 48 KHz, 88.2 KHz and 96 KHz, as defined in the Intel High Definition Audio Specification, with resolutions up to 24 bits. This insures compatibility with all consumer audio gear and allows for convenient integration into home theater systems and media center PCs.

3.4. Headphone Drivers (Restrictions)

Three headphones should not be used simultaneously. Performance degradation will occur when using two headphones simultaneously. See electrical specifications for details.

3.5. Device IDs

Table 2. CODEC IDs

Part Number	DAC SNR dB	VID	DID	Rev ID	Step ID	SSID*	Assm ID*	Dolby	Volume	Pkg Pins
92HD206X	95	8384h	7645h	xxh	xxh	xxxxxxh	xxh	No	Yes	48
92HD206D	95	8384h	7646h	xxh	xxh	xxxxxx1h	xxh	HT/SR	Yes	48

Note: SVIDs, SSIDs and Assembly IDs are read/writable by BIOS. All other ID fields are read-only.

Note: MS refers to Master Studio and HT/SR refers to Home Theater/Sound Room

4. FUNCTIONAL BLOCK DIAGRAMS

4.1. 92HD206

Figure 1. 92HD206 Functional Block Diagram

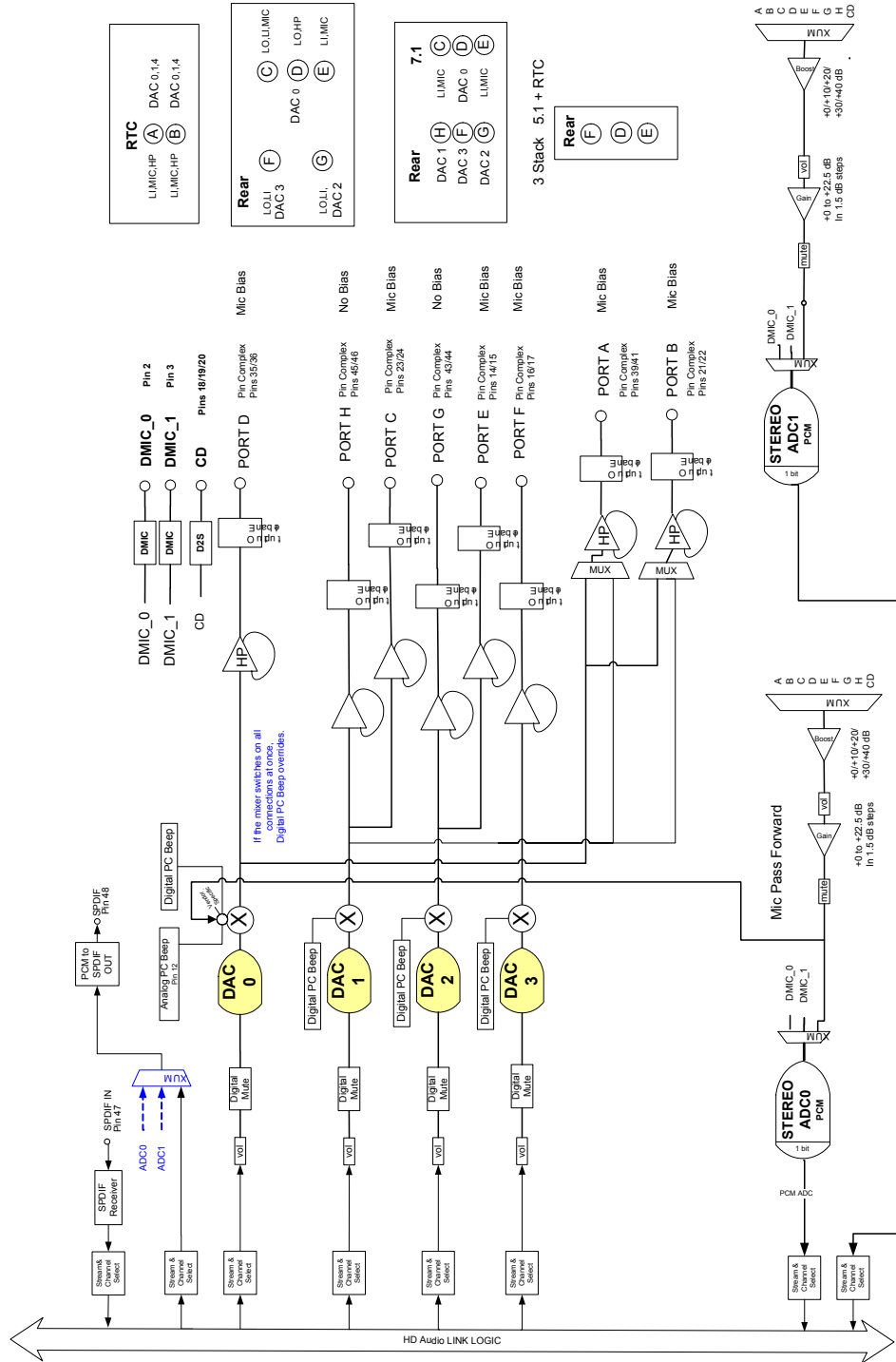

5. WIDGET DIAGRAM

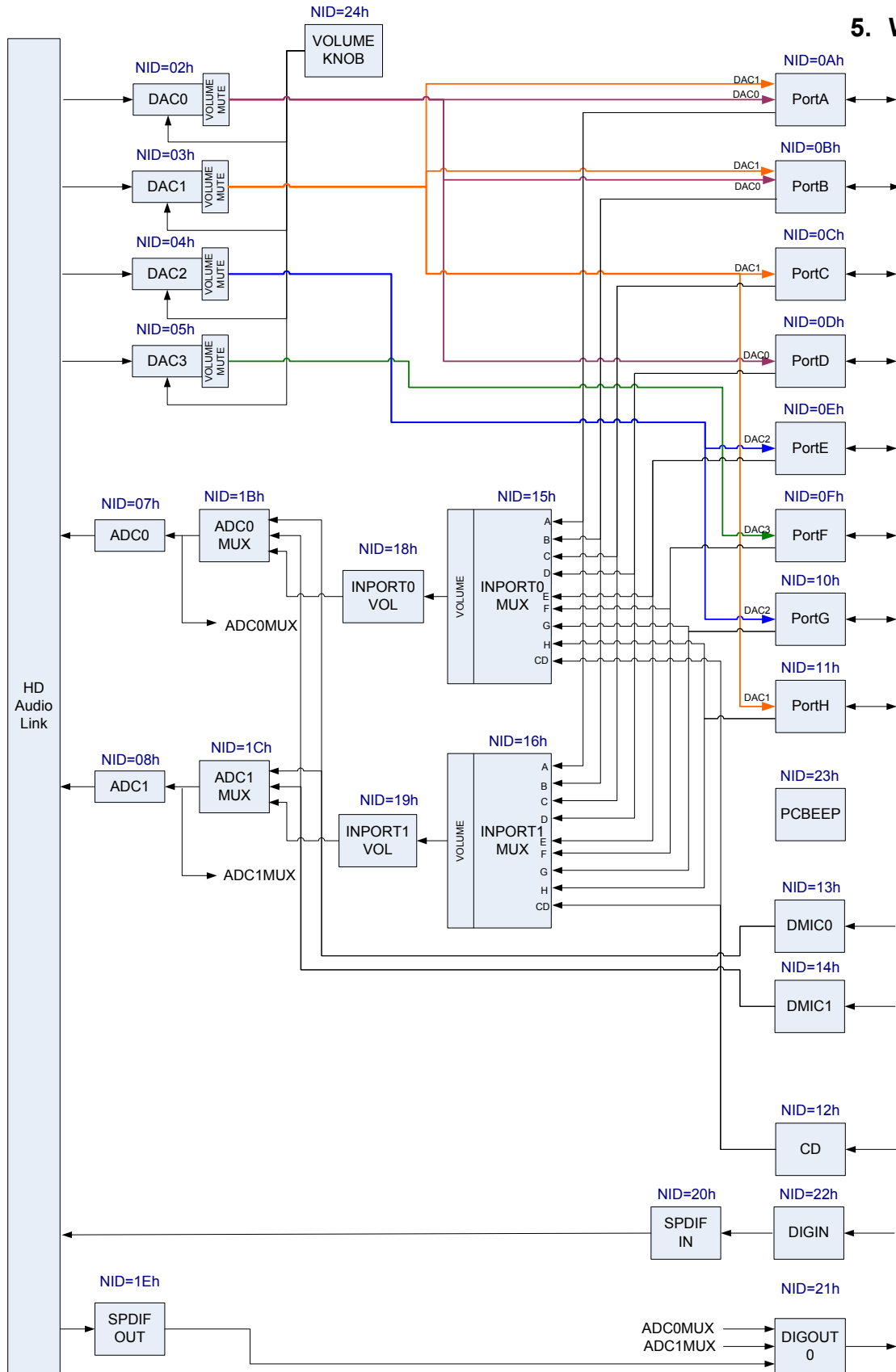

Figure 2. 92HD206 Widget Diagram

5.1. Pin Configuration Default Register Settings

The following table shows the Pin Widget Configuration Default settings.

Table 3. Pin Configuration Default Settings

Pin Name	Port	Location	Device	Connection	Color	Misc	Assoc.	Seq
DigInPin	Not Connected 01b	Mainboard Rear 1h	SPDIF In C	RCA 4h	Gray 2h	Jack Detect Override = 1	9h	0h
DigOutPin	Connect to Jack 00b	Mainboard Rear 1h	SPDIF Out 4h	RCA 4h	Gray 2h	Jack Detect Override = 0	7h	0h
PortAPin	Connect to Jack 00b	Mainboard Front 2h	HP Out 2h	1/8 inch Jack 1h	Green 4h	Jack Detect Override = 0	2h	0h
PortBPin	Connect to Jack 00b	Mainboard Front 2ht	Mic In A	1/8 inch Jack 1h	Pink 9h	Jack Detect Override = 0	8h	0h
PortCPin	Connect to Jack 00b	Mainboard Rear 1h	Line In 8h	1/8 inch Jack 1h	Blue 3h	Jack Detect Override = 0	4h	Eh
PortDPin	Connect to Jack 00b	Mainboard Rear 1h	Line Out 0h	1/8 inch Jack 1h	Green 4h	Jack Detect Override = 0	1h	0h
PortEPin	Connect to Jack 00b	Mainboard Rear 1h	Mic In A	1/8 inch Jack 1h	Pink 9h	Jack Detect Override = 0	4h	0h
PortFPin	Connect to Jack 00b	Mainboard Rear 1h	Line Out 0h	1/8 inch Jack 1h	Black 1h	Jack Detect Override = 0	1h	2h
PortGPin	Connect to Jack 00b	Mainboard Rear 1h	Line Out 0h	1/8 inch Jack 1h	Orange 6h	Jack Detect Override = 0	1h	1h
PortHPin	Connect to Jack 00b	Mainboard Rear 1h	Line Out 0h	1/8 inch Jack 1h	Gray 2h	Jack Detect Override = 0	1h	Fh
CDPin	Not Connected 01b	Internal 01000b	CD 3h	ATAPI Internal 3h	Unknown 0h	Jack Detect Override = 1	Fh	0h

6. WIDGET INFORMATION FOR THE 92HD206 FAMILY

Table 4. High Definition Audio Widget

ID	Widget Name	Description
00h	Root	Root Node
01h	Audio Function Group	Audio Function Group
02h	DAC0	Stereo Output Converter to DAC
03h	DAC1	Stereo Output Converter to DAC
04h	DAC2	Stereo Output Converter to DAC
05h	DAC3	Stereo Output Converter to DAC
06h	Reserved	Reserved
07h	ADC0	Stereo Input Converter to ADC
08h	ADC1	Stereo Input Converter to ADC
09h	Reserved	Reserved
0Ah	Port A	Port A Pin Widget (Configurable as HP, Line In, Line Out, Mic)
0Bh	Port B	Port B Pin Widget (Configurable as HP, Line In, Line Out, Mic)
0Ch	Port C	Port C Pin Widget (Configurable as Line In, Line Out, Mic)
0Dh	Port D	Port D Pin Widget (Configurable as HP, Line In, Line Out, Mic)
0Eh	Port E	Port E Pin Widget (Configurable as Line In, Line Out, Mic)
0Fh	Port F	Port F Pin Widget (Configurable as Line In, Line Out, Mic)
10h	Port G	Port G Pin Widget (Configurable as Line In, Line Out, Mic)
11h	Port H	Port H Pin Widget (Configurable as Line In, Line Out, Mic)
12h	CD	CD Pin Widget
13h	Reserved	Reserved
14h	Reserved	Reserved
15h	InPort0Mux	ADC0 Input Port Mux
16h	InPort1Mux	ADC1 Input Port Mux
17h	Reserved	Reserved
18h	InPort0Vol	ADC0 Input Port Volume
19h	InPort1Vol	ADC1 Input Port Volume
1Ah	Reserved	Reserved
1Bh	ADC0Mux	ADC0 Mux
1Ch	ADC1Mux	ADC1 Mux
1Dh	Reserved	Reserved
1Eh	SPDIF_OUT	Stereo Output for SPDIF_Out
1Fh	Reserved	Reserved

Table 4. High Definition Audio Widget

ID	Widget Name	Description
20h	SPDIF_IN	Stereo Input for SPDIF_In
21h	DigOut	Digital Output Pin
22h	Reserved	Reserved
23h	PCBEEP	Digital PC Beep
24h	VolumeKnob	Master Volume Controls

6.1. Root Node (NID = 0x00)

6.1.1. Root ID

Table 5. Root ID Command Verb Format

	Verb ID	Payload	Response
Get	F00	00	See bitfield table.

Table 6. Root ID Command Response Format

Bit	Bitfield Name	RW	Reset	Description
[31:16]	Vendor	R	0x8384	Vendor ID.
[15:8]	DeviceFix	R	0x76	Fixed portion of Device ID.
[7:0]	DeviceProg	R	0x10	Dependant on device - See device ID table in section 3.5.

6.1.2. Root RevID

Table 7. Root RevID Command Verb Format

	Verb ID	Payload	Response
Get	F00	02	See bitfield table.

Table 8. Root RevID Command Response Format

Bit	Bitfield Name	RW	Reset	Description
[31:24]	Rsvd	R	0x00	Reserved
[23:20]	Major	R	0x1	Major rev number of compliant HD Audio spec.
[19:16]	Minor	R	0x0	Minor rev number of compliant HD Audio spec.
[15:12]	VendorFix	R	0x0	Fixed portion of Vendor's rev number for this device.
[11:8]	VendorProg	R	0x1	Vendor's rev number for this device.
[7:4]	SteppingFix	R	0x0	Fixed portion of vendor stepping number within the Vendor RevID.
[3:0]	SteppingProg	R	0x1	vendor stepping number within the Vendor RevID.

6.1.3. Root NodeInfo

Table 9. Root NodeInfo Command Verb Format

	Verb ID	Payload	Response
Get	F00	04	See bitfield table.

Table 10. Root NodeInfo Command Response Format

Bit	Bitfield Name	RW	Reset	Description
[31:24]	Rsvd2	R	0x00	Reserved
[23:16]	StartNID	R	0x01	Starting node number (NID) of first function group
[15:8]	Rsvd1	R	0x00	Reserved
[7:0]	TotalNodes	R	0x01	Total number of nodes

6.2. AFG Node (NID = 0x01)

6.2.1. AFG Reset

Table 11. AFG Reset Command Verb Format

	Verb ID	Payload	Response
Get	7FF	00	See bitfield table.
Set1	7FF	See bits [7:0] of bitfield table.	0000_0000h

Table 12. AFG Reset Command Response Format

Bit	Bitfield Name	RW	Reset	Description
[31:0]	Response	R	0x0	Reserved. Overlaps Execute.
[0]	Execute	W	0x0	Function Reset. Function Group reset is executed when the Set verb 7FF is written with 8-bit payload of 00h. The CODEC should issue a response to acknowledge receipt of the verb, and then reset the affected Function Group and all associated widgets to their power-on reset values. Some controls such as Configuration Default controls should not be reset. Overlaps Response.

6.2.2. AFG NodeInfo

Table 13. AFG NodeInfo Command Verb Format

	Verb ID	Payload	Response
Get	F00	04	See bitfield table.

Table 14. AFG NodeInfo Command Response Format

Bit	Bitfield Name	RW	Reset	Description
[31:24]	Rsvd2	R	0x0	Reserved
[23:16]	StartNID	R	0x2	Starting node number for function group subordinate nodes.
[15:8]	Rsvd1	R	0x0	Reserved
[7:0]	TotalNodes	R	0x23	Total number of nodes.

6.2.3. AFG Type

Table 15. AFG Type Command Verb Format

	Verb ID	Payload	Response
Get	F00	05	See bitfield table.

Table 16. AFG Type Command Response Format

Bit	Bitfield Name	RW	Reset	Description
[31:9]	Rsvd	R	0x0	Reserved
[8]	UnSol	R	0x1	This node is capable of generating an unsolicited response, and will respond to the Unsolicited Response verb (Verb ID 708h).
[7:0]	NodeType	R	0x01	Node type = Audio Function Group

6.2.4. AFG Type

Table 17. AFG Cap Command Verb Format

	Verb ID	Payload	Response
Get	F00	08	See bitfield table.

Table 18. AFG Cap Command Response Format

Bit	Bitfield Name	RW	Reset	Description
[31:17]	Rsvd3	R	0x0	Reserved
[16]	BeepGen	R	0x1	Optional Beep Generator is present
[15:12]	Rsvd2	R	0x0	Reserved
[11:8]	InputDelay	R	0xD	Typical latency = 13 frames. Number of samples between when the sample is received as an analog signal at the pin and when the digital representation is transmitted on the HD Audio link.
[7:4]	Rsvd1	R	0x0	Reserved
[3:0]	OutputDelay	R	0xD	Typical latency = 13 frames. Number of samples between when the signal is received from the HD Audio link and when it appears as an analog signal at the pin.

6.2.5. AFG PCMCap

Table 19. AFG PCMCap Command Verb Format

	Verb ID	Payload	Response
Get	F00	0A	See bitfield table.

Table 20. AFG PCMCap Command Response Format

Bit	Bitfield Name	RW	Reset	Description
[31:21]	Rsvd2	R	0x0	Reserved
[20]	B32	R	0x0	32 bit audio formats are NOT supported
[19]	B24	R	0x1	24 bit audio formats are supported
[18]	B20	R	0x1	20 bit audio formats are supported
[17]	B16	R	0x1	16 bit audio formats are supported
[16]	B8	R	0x0	8 bit audio formats are NOT supported
[15:12]	Rsvd1	R	0x0	Reserved

Table 20. AFG PCMCap Command Response Format

Bit	Bitfield Name	RW	Reset	Description
[11]	R12	R	0x0	384 KHz rate (8/1*48 KHz) NOT supported
[10]	R11	R	0x1	192.0 KHz rate (4/1*48 KHz) supported
[9]	R10	R	0x1	176.4 KHz rate (4/1*44.1 KHz) supported
[8]	R9	R	0x1	96.0 KHz rate (2/1*48 KHz) supported
[7]	R8	R	0x1	88.2 KHz rate (2/1*44.1 KHz) supported
[6]	R7	R	0x1	48.0 KHz rate supported (REQUIRED)
[5]	R6	R	0x1	44.1 KHz rate supported
[4]	R5	R	0x0	32.0 KHz rate (2/3*48 KHz) supported
[3]	R4	R	0x0	22.05 KHz rate (1/2*44.1 KHz) supported
[2]	R3	R	0x0	16.0 KHz rate (1/3*48 KHz) supported
[1]	R2	R	0x0	11.025 KHz rate (1/4*44.0 KHz) supported
[0]	R1	R	0x0	8.0 KHz rate (1/6*48 KHz) supported

6.2.6. AFG Stream

Table 21. AFG Stream Command Verb Format

	Verb ID	Payload	Response
Get	F00	0B	See bitfield table.

Table 22. AFG Stream Command Response Format

Bit	Bitfield Name	RW	Reset	Description
[31:3]	Rsvd	R	0x0	Reserved
[2]	NonPCM	R	0x0	No support for non-PCM data.
[1]	Float32	R	0x0	No support for Float32 data.
[0]	PCM	R	0x1	PCM-formatted data supported.

6.2.7. AFG InAmpCap

Table 23. AFG InAmpCap Command Verb Format

	Verb ID	Payload	Response
Get	F00	0D	See bitfield table.

Table 24. AFG InAmpCap Command Response Format

Bit	Bitfield Name	RW	Reset	Description
[31]	Mute	R	0x0	No mute capability
[30:23]	Rsvd3	R	0x0	Reserved
[22:16]	StepSize	R	0x5	Size of each step in the gain range = 1.5dB
[15]	Rsvd2	R	0x0	Reserved
[14:8]	NumSteps	R	0x0E	Number of steps in the gain range = 15 (0dB to 22.5 dB)
[7]	Rsvd1	R	0x0	Reserved
[6:0]	Offset	R	0x00	0dB-step is programmed with this offset

6.2.8. AFG SupPwrState

Table 25. AFG SupPwrState Command Verb Format

	Verb ID	Payload	Response
Get	F00	0F	See bitfield table.

Table 26. AFG SupPwrState Command Response Format

Bit	Bitfield Name	RW	Reset	Description
[31:4]	Rsvd	R	0x0	Reserved
[3]	D3Sup	R	0x1	Power State D3 is supported. Allows for lowest possible power consuming state under software control (and still properly respond to a subsequent Power State command).
[2]	D2Sup	R	0x1	Power State D2 is supported. Allows for lowest possible power consuming state from which it can return to fully-on state within 10 ms.

Table 26. AFG SupPwrState Command Response Format

Bit	Bitfield Name	RW	Reset	Description
[1]	D1Sup	R	0x1	Power State D1 is supported. Allows for lowest possible power consuming state from which it can return to fully on state within 10ms, excepting analog pass-through circuits which must remain fully on.
[0]	D0Sup	R	0x1	Power State D0 is supported. Node power state is fully on.

6.2.9. AFG GPIOCnt

Table 27. AFG GPIOCnt Command Verb Format

	Verb ID	Payload	Response
Get	F00	11	See bitfield table.

Table 28. AFG GPIOCnt Command Response Format

Bit	Bitfield Name	RW	Reset	Description
[31]	GPIWake	R	0x1	Wake capability. Assuming the Wake Enable Mask controls are enabled, GPIOs configured as inputs can cause a wake (generate a Status Change event on the link) when there is a change in level on the pin.
[30]	GPIUnsol	R	0x1	Unsolicited Response capability. Assuming the Unsolicited Enable Mask controls are enabled, GPIOs configured as inputs can generate an Unsolicited Response on the link when there is a change in level on the pin.
[29:24]	Rsvd	R	0x0	Reserved
[23:16]	NumGPIs	R	0x00	Number of GPI pins supported by function
[15:8]	NumGPOs	R	0x00	Number of GPO pins supported by function
[7:0]	NumGPIOs	R	0x03 = 48-pin	Number of GPIO pins supported by function

6.2.10. AFG OutAmpCap

Table 29. AFG OutAmpCap Command Verb Format

	Verb ID	Payload	Response
Get	F00	12	See bitfield table.

Table 30. AFG OutAmpCap Command Response Format

Bit	Bitfield Name	RW	Reset	Description
[31]	Mute	R	0x1	Amplifier is capable of muting
[30:23]	Rsvd3	R	0x0	Reserved
[22:16]	StepSize	R	0x02	Size of each step in the gain range = 0.75dB
[15]	Rsvd2	R	0x0	Reserved
[14:8]	NumSteps	R	0x7F	Number of steps in the gain range = 128 (-96dB to +0dB)
[7]	Rsvd1	R	0x0	Reserved
[6:0]	Offset	R	0x7F	0dB-step is programmed with this offset

6.2.11. AFG PwrState

Table 31. AFG PwrState Command Verb Format

	Verb ID	Payload	Response
Get	F05	00	See bitfield table.
Set1	705	See bits [7:0] of bitfield table.	0000_0000h

Table 32. AFG PwrState Command Response Format

Bit	Bitfield Name	RW	Reset	Description
[31:8]	Rsvd2	R	0x0	Reserved
[7:4]	Act	R	0x2	PS-Act: Actual power state of referenced node.
[3:2]	Rsvd1	R	0x0	Reserved
[1:0]	Set	RW	0x2	PS-Set: Current power setting of referenced node. 0: All Powered-On 1: D1 = > PR0, PR1 2: D2 = > PR0, PR1, PR2, PR6, EAPD 3: D3 = > PR6, PR5, PR3, PR2, PR1, PR0, EAPD Note: PR4 is not mapped in HD Audio

6.2.12. AFG UnsolicitedResponse

Table 33. AFG UnsolicitedResponse Command Verb Format

	Verb ID	Payload	Response
Get	F08	00	See bitfield table.
Set1	708	See bits [7:0] of bitfield table.	0000_0000h

Table 34. AFG UnsolicitedResponse Command Response Format

Bit	Bitfield Name	RW	Reset	Description
[31:8]	Rsvd2	R	0x0	Reserved
[7]	En	RW	0x0	Allow generation of Unsolicited Responses.
[6]	Rsvd1	R	0x0	Reserved
[5:0]	Tag	RW	0x0	Software programmable field returned in top six bits (31:26) of every Unsolicited Response generated by this node.

6.2.13. AFG GPIO

Table 35. AFG GPIO Command Verb Format

	Verb ID	Payload	Response
Get	F15	00	See bitfield table.
Set1	715	See bits [7:0] of bitfield table.	0000_0000h

Table 36. AFG GPIO Command Response Format

Bit	Bitfield Name	RW	Reset	Description
[31:5]	Rsvd	R	0x0	Reserved
[4]	Rsvd	RW	0x0	Reserved
[3]	Rsvd	RW	0x0	Reserved
[2]	Data2	RW	0x0	Data for GPIO2. If this GPIO bit is configured as Sticky (edge-sensitive) input, it can be cleared by writing zero (one) here when the corresponding Polarity Control bit is zero (one).

Table 36. AFG GPIO Command Response Format

Bit	Bitfield Name	RW	Reset	Description
[1]	Data1	RW	0x0	Data for GPIO1. If this GPIO bit is configured as Sticky (edge-sensitive) input, it can be cleared by writing zero (one) here when the corresponding Polarity Control bit is zero (one).
[0]	Data0	RW	0x0	Data for GPIO0. If this GPIO bit is configured as Sticky (edge-sensitive) input, it can be cleared by writing zero (one) here when the corresponding Polarity Control bit is zero (one).

6.2.14. AFG GPIOEn

Table 37. AFG GPIOEn Command Verb Format

	Verb ID	Payload	Response
Get	F16	00	See bitfield table.
Set1	716	See bits [7:0] of bitfield table.	0000_0000h

Table 38. AFG GPIOEn Command Response Format

Bit	Bitfield Name	RW	Reset	Description
[31:5]	Rsvd	R	0x0	Reserved
[4]	Rsvd	RW	0x0	Reserved
[3]	Rsvd	RW	0x0	Reserved
[2]	Mask2	RW	0x0	Enable for GPIO2: 0 = pin is disabled (Hi-Z state); 1 = pin is enabled; behavior determined by GPIO Direction control
[1]	Mask1	RW	0x0	Enable for GPIO1: 0 = pin is disabled (Hi-Z state); 1 = pin is enabled; behavior determined by GPIO Direction control
[0]	Mask0	RW	0x0	Enable for GPIO0: 0 = pin is disabled (Hi-Z state); 1 = pin is enabled; behavior determined by GPIO Direction control

6.2.15. AFG GPIODir

Table 39. AFG GPIODir Command Verb Format

	Verb ID	Payload	Response
Get	F17	00	See bitfield table.
Set1	717	See bits [7:0] of bitfield table.	0000_0000h

Table 40. AFG GPIODir Command Response Format

Bit	Bitfield Name	RW	Reset	Description
[31:5]	Rsvd	R	0x0	Reserved
[4]	Rsvd	RW	0x0	Reserved
[3]	Rsvd	RW	0x0	Reserved
[2]	Control2	RW	0x0	Direction control for GPIO2 0 = GPIO signal is configured as input 1 = GPIO signal is configured as output
[1]	Control1	RW	0x0	Direction control for GPIO1 0 = GPIO signal is configured as input 1 = GPIO signal is configured as output
[0]	Control0	RW	0x0	Direction control for GPIO0 0 = GPIO signal is configured as input 1 = GPIO signal is configured as output

6.2.16. AFG GPIOWakeEn

Table 41. AFG GPIOWakeEn Command Verb Format

	Verb ID	Payload	Response
Get	F18	00	See bitfield table.
Set1	718	See bits [7:0] of bitfield table.	0000_0000h

Table 42. AFG GPIOWakeEn Command Response Format

Bit	Bitfield Name	RW	Reset	Description
[31:5]	Rsvd	R	0x0	Reserved
[4]	Rsvd	RW	0x0	Reserved

Table 42. AFG GPIOWakeEn Command Response Format

Bit	Bitfield Name	RW	Reset	Description
[3]	Rsvd	RW	0x0	Reserved
[2]	W2	RW	0x0	Wake enable for GPIO2: 0 = wake-up event is disabled; 1 = when HD Audio link is powered down (RST# is asserted), a wake-up event will trigger a Status Change Request event on the link.
[1]	W1	RW	0x0	Wake enable for GPIO1: 0 = wake-up event is disabled; 1 = when HD Audio link is powered down (RST# is asserted), a wake-up event will trigger a Status Change Request event on the link.
[0]	W0	RW	0x0	Wake enable for GPIO0: 0 = wake-up event is disabled; 1 = when HD Audio link is powered down (RST# is asserted), a wake-up event will trigger a Status Change Request event on the link.

6.2.17. AFG GPIOUnsol

Table 43. AFG GPIOUnsol Command Verb Format

	Verb ID	Payload	Response
Get	F19	00	See bitfield table.
Set1	719	See bits [7:0] of bitfield table.	0000_0000h

Table 44. AFG GPIOUnsol Command Response Format

Bit	Bitfield Name	RW	Reset	Description
[31:5]	Rsvd	R	0x0	Reserved
[4]	Rsvd	RW	0x0	Reserved
[3]	Rsvd	RW	0x0	Reserved

Table 44. AFG GPIOUnsol Command Response Format

Bit	Bitfield Name	RW	Reset	Description
[2]	EnMask2	RW	0x0	Unsolicited enable mask for GPIO2. If set, and the Unsolicited Response control for this widget has been enabled, an unsolicited response will be sent when GPIO0 is configured as input and changes state.
[1]	EnMask1	RW	0x0	Unsolicited enable mask for GPIO1. If set, and the Unsolicited Response control for this widget has been enabled, an unsolicited response will be sent when GPIO0 is configured as input and changes state.
[0]	EnMask0	RW	0x0	Unsolicited enable mask for GPIO0. If set, and the Unsolicited Response control for this widget has been enabled, an unsolicited response will be sent when GPIO0 is configured as input and changes state.

6.2.18. AFG GPIOSticky

Table 45. AFG GPIOSticky Command Verb Format

	Verb ID	Payload	Response
Get	F1A	00	See bitfield table.
Set1	71A	See bits [7:0] of bitfield table.	0000_0000h

Table 46. AFG GPIOSticky Command Response Format

Bit	Bitfield Name	RW	Reset	Description
[31:5]	Rsvd	R	0x0	Reserved
[4]	Rsvd	RW	0x0	Reserved
[3]	Rsvd	RW	0x0	Reserved
[2]	Mask2	RW	0x0	GPIO2 input type (when configured as input): 0 = Non-Sticky (level-sensitive); 1 = Sticky (edge-sensitive). Sticky inputs are cleared by writing zero to corresponding bit of GPIO Data register. GPIOPolarity determines rising or falling edge sensitivity.

Table 46. AFG GPIOSticky Command Response Format

Bit	Bitfield Name	RW	Reset	Description
[1]	Mask1	RW	0x0	GPIO1 input type (when configured as input): 0 = Non-Sticky (level-sensitive); 1 = Sticky (edge-sensitive). Sticky inputs are cleared by writing zero to corresponding bit of GPIO Data register. GPIOPolarity determines rising or falling edge sensitivity.
[0]	Mask0	RW	0x0	GPIO0 input type (when configured as input): 0 = Non-Sticky (level-sensitive); 1 = Sticky (edge-sensitive). Sticky inputs are cleared by writing zero to corresponding bit of GPIO Data register. GPIOPolarity determines rising or falling edge sensitivity.

6.2.19. AFG SubID

Table 47. AFG SubID Command Verb Format

	Verb ID	Payload	Response
Get	F20	00	See bitfield table.
Set1	720	See bits [7:0] of bitfield table.	0000_0000h
Set2	721	See bits [7:0] of bitfield table.	0000_0000h
Set3	722	See bits [7:0] of bitfield table.	0000_0000h
Set4	723	See bits [7:0] of bitfield table.	0000_0000h

Table 48. AFG SubID Command Response Format

Bit	Bitfield Name	RW	Reset	Description
[31:24]	Subsys3	RW	0x00	Subsystem ID. (Any non-zero value)
[23:16]	Subsys2	RW	0x00	Subsystem ID. (Any non-zero value)
[15:8]	Subsys1	RW	0x01	Subsystem ID. (Any non-zero value)
[7:0]	Assembly	RW	0x00	Assembly ID. (Not applicable to CODEC vendors)

6.2.20. AFG TCKT

Table 49. AFG TCKT Command Verb Format

	Verb ID	Payload	Response
Get	FE5	00	See bitfield table.
Set1	7E5	See bits [7:0] of bitfield table.	0000_0000h

Table 50. AFG TCKT Command Response Format

Bit	Bitfield Name	RW	Reset	Description
[31:8]	Rsvd	R	0x0	Reserved
[7]	AnaD3Enable	RW	0x0	D3 enable signal for analog
[6:0]	TCKT	RW	0x0	Test circuit (default reset on) TBD [6:0]

6.2.21. AFG Sply

Table 51. AFG Sply Command Verb Format

	Verb ID	Payload	Response
Get	FE6	00	See bitfield table.
Set1	7E6	See bits [7:0] of bitfield table.	0000_0000h

Table 52. AFG Sply Command Response Format

Bit	Bitfield Name	RW	Reset	Description
[31:7]	Rsvd	R	0x0	Reserved
[6:5]	IBIAS	RW	0x0	00 = Normal Current; 01 = 80% nominal Analog Current; 10 = 120% nominal Analog Current; 11 = 140% nominal Analog Current
[4]	PinLvl	RW	0x1	0 = low-level SPDIF Input (special buffer for low level signals) 1 = standard SPDIF Input (for high level signals)
[3:0]	SplyOvr	RW	0x0	Supply Override Control. See Table below. 0 = invert ADC supply; 1 = invert DAC supply; 2 = supply value; 3 = supply override enable

6.2.22. AFG DACMode

Table 53. AFG DACMode Command Verb Format

	Verb ID	Payload	Response
Get	FEB	00	See bitfield table.
Set1	7EB	See bits [7:0] of bitfield table.	0000_0000h

Table 54. AFG DACMode Command Response Format

Bit	Bitfield Name	RW	Reset	Description
[31:7]	Rsvd2	R	0x0	Reserved
[6]	ADCMixDAC	RW	0x0	Enable mixing of ADC with DAC signal (for karaoke)
[5]	FadeFast	RW	0x0	Gain ramps at the maximum rate
[4]	FadeLog	RW	0x0	Gain ramping is dB linear instead of voltage linear over time
[3:0]	Rsvd	R	0x0	Reserved

6.2.23. AFG GPIOIrty

Table 55. AFG GPIOIrty Command Verb Format

	Verb ID	Payload	Response
Get	FEE	00	See bitfield table.
Set1	7EE	See bits [7:0] of bitfield table.	0000_0000h

Table 56. AFG GPIOIrty Command Response Format

Bit	Bitfield Name	RW	Reset	Description
[31:5]	Rsvd	R	0x0	Reserved
[4]	Rsvd	RW	0x0	Reserved
[3]	Rsvd	RW	0x0	Reserved

Table 56. AFG GPIOIrty Command Response Format

Bit	Bitfield Name	RW	Reset	Description
[2]	GP2	RW	0x1	GPIO2 Polarity If configured as an output: 0 = inverting 1 = non-inverting If configured as a non-sticky input: 0 = inverting 1 = non-inverting If configured as a sticky input: 0 = falling events will be detected 1 = rising events will be detected
[1]	GP1	RW	0x1	GPIO1 Polarity; If configured as an output: 0 = inverting 1 = non-inverting If configured as a non-sticky input: 0 = inverting 1 = non-inverting If configured as a sticky input: 0 = falling events will be detected 1 = rising events will be detected
[0]	GP0	RW	0x1	GPIO0 Polarity; If configured as an output: 0 = inverting 1 = non-inverting If configured as a non-sticky input: 0 = inverting 1 = non-inverting If configured as a sticky input: 0 = falling events will be detected 1 = rising events will be detected

6.2.24. AFG GPIODrive

Table 57. AFG GPIODrive Command Verb Format

	Verb ID	Payload	Response
Get	FEF	00	See bitfield table.
Set1	7EF	See bits [7:0] of bitfield table.	0000_0000h

Table 58. AFG GPIO Drive Command Response Format

Bit	Bitfield Name	RW	Reset	Description
[31:5]	Rsvd	R	0x0	Reserved
[4]	Rsvd	RW	0x0	Reserved
[3]	Rsvd	RW	0x0	Reserved
[2]	OD2	RW	0x0	GPIO2 Drive Mode; 0 = push-pull (drive 0 and 1), 1 = open drain (drive 0, float for 1).
[1]	OD1	RW	0x0	GPIO1 Drive Mode; 0 = push-pull (drive 0 and 1), 1 = open drain (drive 0, float for 1).
[0]	OD0	RW	0x0	GPIO0 Drive Mode; 0 = push-pull (drive 0 and 1), 1 = open drain (drive 0, float for 1).

6.2.25. AFG DMic

Table 59. AFG DMic Command Verb Format

	Verb ID	Payload	Response
Get	FF0	00	See bitfield table.
Set1	7F0	See bits [7:0] of bitfield table.	0000_0000h

Table 60. AFG DMic Command Response Format

Bit	Bitfield Name	RW	Reset	Description
[31:4]	Rsvd	R	0x0	Reserved
[3:2]	PhAdj	RW	0x0	Selects what phase of the DigMic clock the data should be latched: 0 = rising edge, 1 = center of high, 2 = falling edge, 3 = center of low.
[1:0]	Rate	RW	0x2	Selects the DigMic rate: 0 = 4.704 MHz, 1 = 3.528 MHz, 2 = 2.352 MHz, 3 = 1.176 MHz.

6.3. DAC0 Node (NID = 0x02)

6.3.1. DAC0 Cnvtr

Table 61. DAC0 Cnvtr Command Verb Format

	Verb ID	Payload	Response
Get	A	0000	See bitfield table.
Set1	2	See bits [15:0] of bitfield table.	0000_0000h

Table 62. DAC0 Cnvtr Command Response Format

Bit	Bitfield Name	RW	Reset	Description
[31:16]	Rsvd2	R	0x0	Reserved
[15]	StrmType	R	0x0	Stream Type: only PCM streams are supported by this widget.
[14]	FrmtSmplRate	RW	0x0	Sample Base Rate 0 = 48 KHz 1 = 44.1 KHz
[13:11]	SmplRateMultp	RW	0x0	Sample Base Rate Multiple 000 = 48 KHz/44.1 KHz or less 001 = x2 010 = Reserved (x3) 011 = x4 100-111 = Reserved
[10:8]	SmplRateDiv	RW	0x0	Sample Base Rate Divisor 000 = Divide by 1 001 = Divide by 2 010 = Divide by 3 011 = Divide by 4 100 = Divide by 5 101 = Divide by 6 110 = Divide by 7 111 = Divide by 8
[7]	Rsvd1	R	0x0	Reserved

Table 62. DAC0 Cnvtr Command Response Format

Bit	Bitfield Name	RW	Reset	Description
[6:4]	BitsPerSmpl	RW	0x3	Bits per Sample 000 = 8 bits 001 = 16 bits 010 = 20 bits 011 = 24 bits 100-111 = Reserved
[3:0]	NmbrChan	RW	0x1	Number of Channels Number of channels in each frame of the stream. 0000 = 1 channel 0001 = 2 channels ... 1111 = 16 channels

6.3.2. DAC0 OutAmpRight

Table 63. DAC0 OutAmpRight Command Verb Format

	Verb ID	Payload	Response
Get	B80	00	See bitfield table.
Set1	390	See bits [7:0] of bitfield table.	0000_0000h

Table 64. DAC0 OutAmpRight Command Response Format

Bit	Bitfield Name	RW	Reset	Description
[31:8]	Rsvd	R	0x0	Reserved
[7]	Mute	RW	0x1	1 = mute is active
[6:0]	Gain	RW	0x7F	Amplifier gain step number

6.3.3. DAC0 OutAmpLeft

Table 65. DAC0 OutAmpLeft Command Verb Format

	Verb ID	Payload	Response
Get	BA0	00	See bitfield table.
Set1	3A0	See bits [7:0] of bitfield table.	0000_0000h

Table 66. DAC0 OutAmpLeft Command Response Format

Bit	Bitfield Name	RW	Reset	Description
[31:8]	Rsvd	R	0x0	Reserved
[7]	Mute	RW	0x1	1 = mute is active
[6:0]	Gain	RW	0x7F	Amplifier gain step number

6.3.4. DAC0 WCap

Table 67. DAC0 WCap Command Verb Format

	Verb ID	Payload	Response
Get	F00	09	See bitfield table.

Table 68. DAC0 WCap Command Response Format

Bit	Bitfield Name	RW	Reset	Description
[31:24]	Rsvd2	R	0x0	Reserved
[23:20]	Type	R	0x0	Widget type = Audio Output
[19:16]	Delay	R	0xD	Number of sample delays through widget
[15:12]	Rsvd1	R	0x0	Reserved
[11]	SwapCap	R	0x1	Left and right channels can be swapped
[10]	PwrCntrl	R	0x1	Power State control is supported
[9]	Dig	R	0x0	Widget supports an Analog stream
[8]	ConnList	R	0x0	No connection list is present
[7]	UnSolCap	R	0x0	No support for Unsolicited Response
[6]	ProcWidget	R	0x0	No Processing Controls parameter.
[5]	Stripe	R	0x0	No support for striping
[4]	FormatOvrd	R	0x0	No format info; use default format parameters from Audio Function node instead
[3]	AmpParOvrd	R	0x0	No amplifier info; use default amplifier parameters from Audio Function node instead

Table 68. DAC0 WCap Command Response Format

Bit	Bitfield Name	RW	Reset	Description
[2]	OutAmpPrsnt	R	0x1	Output amp
[1]	InAmpPrsnt	R	0x0	No input amp
[0]	Stereo	R	0x1	Stereo widget

6.3.5. DAC0 PwrState

Table 69. DAC0 PwrState Command Verb Format

	Verb ID	Payload	Response
Get	F05	00	See bitfield table.
Set1	705	See bits [7:0] of bitfield table.	0000_0000h

Table 70. DAC0 PwrState Command Response Format

Bit	Bitfield Name	RW	Reset	Description
[31:8]	Rsvd2	R	0x0	Reserved
[7:4]	Act	R	0x3	PS-Act: Actual power state of referenced node.
[3:2]	Rsvd1	R	0x0	Reserved
[1:0]	Set	RW	0x3	PS-Set: Current power setting of referenced node. 00 - Fully on. 01 - Fully on. 10 - Fully on. 11 - Powered down.

6.3.6. DAC0 CnvtrID

Table 71. DAC0 CnvtrID Command Verb Format

	Verb ID	Payload	Response
Get	F06	00	See bitfield table.
Set1	706	See bits [7:0] of bitfield table.	0000_0000h

Table 72. DAC0 CnvtrID Command Response Format

Bit	Bitfield Name	RW	Reset	Description
[31:8]	Rsvd	R	0x0	Reserved
[7:4]	Strm	RW	0x0	Software-programmable integer representing link stream ID used by the converter widget. By convention stream 0 is reserved as unused.
[3:0]	Ch	RW	0x0	Integer representing lowest channel used by converter.

6.3.7. DAC0 LR

Table 73. DAC0 LR Command Verb Format

	Verb ID	Payload	Response
Get	F0C	00	See bitfield table.
Set1	70C	See bits [7:0] of bitfield table.	0000_0000h

Table 74. DAC0 LR Command Response Format

Bit	Bitfield Name	RW	Reset	Description
[31:3]	Rsvd2	R	0x0	Reserved
[2]	SwapEn	RW	0x0	1 = enable swapping of left and right channels.
[1:0]	Rsvd1	R	0x0	Reserved

6.4. DAC1 Node (NID = 0x03)

6.4.1. DAC1 Cnvtr

Table 75. DAC1 Cnvtr Command Verb Format

	Verb ID	Payload	Response
Get	A	0000	See bitfield table.
Set1	2	See bits [15:0] of bitfield table.	0000_0000h

Table 76. DAC1 Cnvtr Command Response Format

Bit	Bitfield Name	RW	Reset	Description
[31:16]	Rsvd2	R	0x0	Reserved
[15]	StrmType	R	0x0	Stream Type: only PCM streams are supported by this widget.
[14]	FrmtSmplRate	RW	0x0	Sample Base Rate 0 = 48 KHz 1 = 44.1 KHz
[13:11]	SmplRateMultp	RW	0x0	Sample Base Rate Multiple 000 = 48 KHz / 44.1 KHz or less 001 = x2 010 = Reserved (x3) 011 = x4 100-111 = Reserved
[10:8]	SmplRateDiv	RW	0x0	Sample Base Rate Divisor 000 = Divide by 1 001 = Divide by 2 010 = Divide by 3 011 = Divide by 4 100 = Divide by 5 101 = Divide by 6 110 = Divide by 7 111 = Divide by 8
[7]	Rsvd1	R	0x0	Reserved
[6:4]	BitsPerSmpl	RW	0x3	Bits per Sample 000 = 8 bits 001 = 16 bits 010 = 20 bits 011 = 24 bits 100-111 = Reserved
[3:0]	NmbrChan	RW	0x1	Number of Channels Number of channels in each frame of the stream. 0000 = 1 channel 0001 = 2 channels ... 1111 = 16 channels

6.4.2. DAC1 OutAmpRight

Table 77. DAC1 OutAmpRight Command Verb Format

	Verb ID	Payload	Response
Get	B80	00	See bitfield table.
Set1	390	See bits [7:0] of bitfield table.	0000_0000h

Table 78. DAC1 OutAmpRight Command Response Format

Bit	Bitfield Name	RW	Reset	Description
[31:8]	Rsvd	R	0x0	Reserved
[7]	Mute	RW	0x1	1 = mute is active
[6:0]	Gain	RW	0x7F	Amplifier gain step number

6.4.3. DAC1 OutAmpLeft

Table 79. DAC1 OutAmpLeft Command Verb Format

	Verb ID	Payload	Response
Get	BA0	00	See bitfield table.
Set1	3A0	See bits [7:0] of bitfield table.	0000_0000h

Table 80. DAC1 OutAmpLeft Command Response Format

Bit	Bitfield Name	RW	Reset	Description
[31:8]	Rsvd	R	0x0	Reserved
[7]	Mute	RW	0x1	1 = mute is active
[6:0]	Gain	RW	0x7F	Amplifier gain step number

6.4.4. DAC1 WCap

Table 81. DAC1 WCap Command Verb Format

	Verb ID	Payload	Response
Get	F00	09	See bitfield table.

Table 82. DAC1 WCap Command Response Format

Bit	Bitfield Name	RW	Reset	Description
[31:24]	Rsvd2	R	0x0	Reserved
[23:20]	Type	R	0x0	Widget type = Audio Output
[19:16]	Delay	R	0xD	Number of sample delays through widget
[15:12]	Rsvd1	R	0x0	Reserved
[11]	SwapCap	R	0x1	Left and right channels can be swapped
[10]	PwrCntrl	R	0x1	Power State control is supported
[9]	Dig	R	0x0	Widget supports an Analog stream
[8]	ConnList	R	0x0	No connection list is present
[7]	UnSolCap	R	0x0	No support for Unsolicited Response
[6]	ProcWidget	R	0x0	No Processing Controls parameter.
[5]	Stripe	R	0x0	No support for striping
[4]	FormatOvrd	R	0x0	No format info; use default format parameters from Audio Function node instead
[3]	AmpParOvrd	R	0x0	No amplifier info; use default amplifier parameters from Audio Function node instead
[2]	OutAmpPrsnt	R	0x1	Output amp
[1]	InAmpPrsnt	R	0x0	No input amp
[0]	Stereo	R	0x1	Stereo widget

6.4.5. DAC1 PwrState

Table 83. DAC1 PwrState Command Verb Format

	Verb ID	Payload	Response
Get	F05	00	See bitfield table.
Set1	705	See bits [7:0] of bitfield table.	0000_0000h

Table 84. DAC1 PwrState Command Response Format

Bit	Bitfield Name	RW	Reset	Description
[31:8]	Rsvd2	R	0x0	Reserved
[7:4]	Act	R	0x3	PS-Act: Actual power state of referenced node.
[3:2]	Rsvd1	R	0x0	Reserved
[1:0]	Set	RW	0x3	PS-Set: Current power setting of referenced node. 00 - Fully on. 01 - Fully on. 10 - Fully on. 11 - Powered down.

6.4.6. DAC1 CnvtrID

Table 85. DAC1 CnvtrID Command Verb Format

	Verb ID	Payload	Response
Get	F06	00	See bitfield table.
Set1	706	See bits [7:0] of bitfield table.	0000_0000h

Table 86. DAC1 CnvtrID Command Response Format

Bit	Bitfield Name	RW	Reset	Description
[31:8]	Rsvd	R	0x0	Reserved
[7:4]	Strm	RW	0x0	Software-programmable integer representing link stream ID used by the converter widget. By convention stream 0 is reserved as unused.
[3:0]	Ch	RW	0x0	Integer representing lowest channel used by converter.

6.4.7. DAC1 LR

Table 87. DAC1 LR Command Verb Format

	Verb ID	Payload	Response
Get	F0C	00	See bitfield table.
Set1	70C	See bits [7:0] of bitfield table.	0000_0000h

Table 88. DAC1 LR Command Response Format

Bit	Bitfield Name	RW	Reset	Description
[31:3]	Rsvd2	R	0x0	Reserved
[2]	SwapEn	RW	0x0	1 = enable swapping of left and right channels.
[1:0]	Rsvd1	R	0x0	Reserved

6.5. DAC2 Node (NID = 0x04)

6.5.1. DAC2 Cnvtr

Table 89. DAC2 Cnvtr Command Verb Format

	Verb ID	Payload	Response
Get	A	0000	See bitfield table.
Set1	2	See bits [15:0] of bitfield table.	0000_0000h

Table 90. DAC2 Cnvtr Command Response Format

Bit	Bitfield Name	RW	Reset	Description
[31:16]	Rsvd2	R	0x0	Reserved
[15]	StrmType	R	0x0	Stream Type: only PCM streams are supported by this widget.
[14]	FrmtSmplRate	RW	0x0	Sample Base Rate 0 = 48 KHz 1 = 44.1 KHz

Table 90. DAC2 Cnvtr Command Response Format

Bit	Bitfield Name	RW	Reset	Description
[13:11]	SmplRateMultp	RW	0x0	Sample Base Rate Multiple 000 = 48 KHz / 44.1 KHz or less 001 = x2 010 = Reserved (x3) 011 = x4 100-111 = Reserved
[10:8]	SmplRateDiv	RW	0x0	Sample Base Rate Divisor 000 = Divide by 1 001 = Divide by 2 010 = Divide by 3 011 = Divide by 4 100 = Divide by 5 101 = Divide by 6 110 = Divide by 7 111 = Divide by 8
[7]	Rsvd1	R	0x0	Reserved
[6:4]	BitsPerSmpl	RW	0x3	Bits per Sample 000 = 8 bits 001 = 16 bits 010 = 20 bits 011 = 24 bits 100-111 = Reserved
[3:0]	NmbrChan	RW	0x1	Number of Channels Number of channels in each frame of the stream. 0000 = 1 channel 0001 = 2 channels ... 1111 = 16 channels

6.5.2. DAC2 OutAmpRight

Table 91. DAC2 OutAmpRight Command Verb Format

	Verb ID	Payload	Response
Get	B80	00	See bitfield table.
Set1	390	See bits [7:0] of bitfield table.	0000_0000h

Table 92. DAC2 OutAmpRight Command Response Format

Bit	Bitfield Name	RW	Reset	Description
[31:8]	Rsvd	R	0x0	Reserved
[7]	Mute	RW	0x1	1 = mute is active
[6:0]	Gain	RW	0x7F	Amplifier gain step number

6.5.3. DAC2 OutAmpLeft

Table 93. DAC2 OutAmpLeft Command Verb Format

	Verb ID	Payload	Response
Get	BA0	00	See bitfield table.
Set1	3A0	See bits [7:0] of bitfield table.	0000_0000h

Table 94. DAC2 OutAmpLeft Command Response Format

Bit	Bitfield Name	RW	Reset	Description
[31:8]	Rsvd	R	0x0	Reserved
[7]	Mute	RW	0x1	1 = mute is active
[6:0]	Gain	RW	0x7F	Amplifier gain step number

6.5.4. DAC2 WCap

Table 95. DAC2 WCap Command Verb Format

	Verb ID	Payload	Response
Get	F00	09	See bitfield table.

Table 96. DAC2 WCap Command Response Format

Bit	Bitfield Name	RW	Reset	Description
[31:24]	Rsvd2	R	0x0	Reserved
[23:20]	Type	R	0x0	Widget type = Audio Output
[19:16]	Delay	R	0xD	Number of sample delays through widget

Table 96. DAC2 WCap Command Response Format

Bit	Bitfield Name	RW	Reset	Description
[15:12]	Rsvd1	R	0x0	Reserved
[11]	SwapCap	R	0x1	Left and right channels can be swapped
[10]	PwrCntrl	R	0x1	Power State control is supported
[9]	Dig	R	0x0	Widget supports an Analog stream
[8]	ConnList	R	0x0	No connection list is present
[7]	UnSolCap	R	0x0	No support for Unsolicited Response
[6]	ProcWidget	R	0x0	No Processing Controls parameter.
[5]	Stripe	R	0x0	No support for striping
[4]	FormatOvrđ	R	0x0	No format info; use default format parameters from Audio Function node instead
[3]	AmpParOvrđ	R	0x0	No amplifier info; use default amplifier parameters from Audio Function node instead
[2]	OutAmpPrsnt	R	0x1	Output amp
[1]	InAmpPrsnt	R	0x0	No input amp
[0]	Stereo	R	0x1	Stereo widget

6.5.5. DAC2 PwrState

Table 97. DAC2 PwrState Command Verb Format

	Verb ID	Payload	Response
Get	F05	00	See bitfield table.
Set1	705	See bits [7:0] of bitfield table.	0000_0000h

Table 98. DAC2 PwrState Command Response Format

Bit	Bitfield Name	RW	Reset	Description
[31:8]	Rsvd2	R	0x0	Reserved
[7:4]	Act	R	0x3	PS-Act: Actual power state of referenced node.

Table 98. DAC2 PwrState Command Response Format

Bit	Bitfield Name	RW	Reset	Description
[3:2]	Rsvd1	R	0x0	Reserved
[1:0]	Set	RW	0x3	PS-Set: Current power setting of referenced node. 00 - Fully on. 01 - Fully on. 10 - Fully on. 11 - Powered down.

6.5.6. DAC2 CnvtrID

Table 99. DAC2 CnvtrID Command Verb Format

	Verb ID	Payload	Response
Get	F06	00	See bitfield table.
Set1	706	See bits [7:0] of bitfield table.	0000_0000h

Table 100. DAC2 CnvtrID Command Response Format

Bit	Bitfield Name	RW	Reset	Description
[31:8]	Rsvd	R	0x0	Reserved
[7:4]	Strm	RW	0x0	Software-programmable integer representing link stream ID used by the converter widget. By convention stream 0 is reserved as unused.
[3:0]	Ch	RW	0x0	Integer representing lowest channel used by converter.

6.5.7. DAC2 LR

Table 101. DAC2 LR Command Verb Format

	Verb ID	Payload	Response
Get	F0C	00	See bitfield table.
Set1	70C	See bits [7:0] of bitfield table.	0000_0000h

Table 102. DAC2 LR Command Response Format

Bit	Bitfield Name	RW	Reset	Description
[31:3]	Rsvd2	R	0x0	Reserved
[2]	SwapEn	RW	0x0	1 = enable swapping of left and right channels.
[1:0]	Rsvd1	R	0x0	Reserved

6.6. DAC3 Node (NID = 0x05)

6.6.1. DAC3 Cnvtr

Table 103. DAC3 Cnvtr Command Verb Format

	Verb ID	Payload	Response
Get	A	0000	See bitfield table.
Set1	2	See bits [15:0] of bitfield table.	0000_0000h

Table 104. DAC3 Cnvtr Command Response Format

Bit	Bitfield Name	RW	Reset	Description
[31:16]	Rsvd2	R	0x0	Reserved
[15]	StrmType	R	0x0	Stream Type: only PCM streams are supported by this widget.
[14]	FrmtSmpRate	RW	0x0	Sample Base Rate 0 = 48 KHz 1 = 44.1 KHz
[13:11]	SmpRateMultp	RW	0x0	Sample Base Rate Multiple 000 = 48 KHz / 44.1 KHz or less 001 = x2 010 = Reserved (x3) 011 = x4 100-111 = Reserved

Table 104. DAC3 Cnvtr Command Response Format

Bit	Bitfield Name	RW	Reset	Description
[10:8]	SmplRateDiv	RW	0x0	Sample Base Rate Divisor 000 = Divide by 1 001 = Divide by 2 010 = Divide by 3 011 = Divide by 4 100 = Divide by 5 101 = Divide by 6 110 = Divide by 7 111 = Divide by 8
[7]	Rsvd1	R	0x0	Reserved
[6:4]	BitsPerSmpl	RW	0x3	Bits per Sample 000 = 8 bits 001 = 16 bits 010 = 20 bits 011 = 24 bits 100-111 = Reserved
[3:0]	NmbrChan	RW	0x1	Number of Channels Number of channels in each frame of the stream. 0000 = 1 channel 0001 = 2 channels ... 1111 = 16 channels

6.6.2. DAC3 OutAmpRight

Table 105. DAC3 OutAmpRight Command Verb Format

	Verb ID	Payload	Response
Get	B80	00	See bitfield table.
Set1	390	See bits [7:0] of bitfield table.	0000_0000h

Table 106. DAC3 OutAmpRight Command Response Format

Bit	Bitfield Name	RW	Reset	Description
[31:8]	Rsvd	R	0x0	Reserved
[7]	Mute	RW	0x1	1 = mute is active
[6:0]	Gain	RW	0x7F	Amplifier gain step number

6.6.3. DAC3 OutAmpLeft

Table 107. DAC3 OutAmpLeft Command Verb Format

	Verb ID	Payload	Response
Get	BA0	00	See bitfield table.
Set1	3A0	See bits [7:0] of bitfield table.	0000_0000h

Table 108. DAC3 OutAmpLeft Command Response Format

Bit	Bitfield Name	RW	Reset	Description
[31:8]	Rsvd	R	0x0	Reserved
[7]	Mute	RW	0x1	1 = mute is active
[6:0]	Gain	RW	0x7F	Amplifier gain step number

6.6.4. DAC3 WCap

Table 109. DAC3 WCap Command Verb Format

	Verb ID	Payload	Response
Get	F00	09	See bitfield table.

Table 110. DAC3 WCap Command Response Format

Bit	Bitfield Name	RW	Reset	Description
[31:24]	Rsvd2	R	0x0	Reserved
[23:20]	Type	R	0x0	Widget type = Audio Output
[19:16]	Delay	R	0xD	Number of sample delays through widget
[15:12]	Rsvd1	R	0x0	Reserved
[11]	SwapCap	R	0x1	Left and right channels can be swapped
[10]	PwrCntrl	R	0x1	Power State control is supported
[9]	Dig	R	0x0	Widget supports an Analog stream
[8]	ConnList	R	0x0	No connection list is present
[7]	UnSolCap	R	0x0	No support for Unsolicited Response

Table 110. DAC3 WCap Command Response Format

Bit	Bitfield Name	RW	Reset	Description
[6]	ProcWidget	R	0x0	No Processing Controls parameter.
[5]	Stripe	R	0x0	No support for striping
[4]	FormatOvrd	R	0x0	No format info; use default format parameters from Audio Function node instead
[3]	AmpParOvrd	R	0x0	No amplifier info; use default amplifier parameters from Audio Function node instead
[2]	OutAmpPrsnt	R	0x1	Output amp
[1]	InAmpPrsnt	R	0x0	No input amp
[0]	Stereo	R	0x1	Stereo widget

6.6.5. DAC3 PwrState

Table 111. DAC3 PwrState Command Verb Format

	Verb ID	Payload	Response
Get	F05	00	See bitfield table.
Set1	705	See bits [7:0] of bitfield table.	0000_0000h

Table 112. DAC3 PwrState Command Response Format

Bit	Bitfield Name	RW	Reset	Description
[31:8]	Rsvd2	R	0x0	Reserved
[7:4]	Act	R	0x3	PS-Act: Actual power state of referenced node.
[3:2]	Rsvd1	R	0x0	Reserved
[1:0]	Set	RW	0x3	PS-Set: Current power setting of referenced node. 00 - Fully on. 01 - Fully on. 10 - Fully on. 11 - Powered down.

6.6.6. *DAC3 CnvtrID*

Table 113. DAC3 CnvtrID Command Verb Format

	Verb ID	Payload	Response
Get	F06	00	See bitfield table.
Set1	706	See bits [7:0] of bitfield table.	0000_0000h

Table 114. DAC3 CnvtrID Command Response Format

Bit	Bitfield Name	RW	Reset	Description
[31:8]	Rsvd	R	0x0	Reserved
[7:4]	Strm	RW	0x0	Software-programmable integer representing link stream ID used by the converter widget. By convention stream 0 is reserved as unused.
[3:0]	Ch	RW	0x0	Integer representing lowest channel used by converter.

6.6.7. *DAC3 LR*

Table 115. DAC3 LR Command Verb Format

	Verb ID	Payload	Response
Get	F0C	00	See bitfield table.
Set1	70C	See bits [7:0] of bitfield table.	0000_0000h

Table 116. DAC3 LR Command Response Format

Bit	Bitfield Name	RW	Reset	Description
[31:3]	Rsvd2	R	0x0	Reserved
[2]	SwapEn	RW	0x0	1 = enable swapping of left and right channels.
[1:0]	Rsvd1	R	0x0	Reserved

6.7. ADC0 Node (NID = 0x07)

6.7.1. ADC0 Cnvtr

Table 117. ADC0 Cnvtr Command Verb Format

	Verb ID	Payload	Response
Get	A	0000	See bitfield table.
Set1	2	See bits [15:0] of bitfield table.	0000_0000h

Table 118. ADC0 Cnvtr Command Response Format

Bit	Bitfield Name	RW	Reset	Description
[31:16]	Rsvd2	R	0x0	Reserved
[15]	StrmType	R	0x0	Stream Type: only PCM streams are supported by this widget.
[14]	FrmtSmplRate	RW	0x0	Sample Base Rate 0 = 48 KHz 1 = 44.1 KHz
[13:11]	SmplRateMultp	RW	0x0	Sample Base Rate Multiple 000 = 48 KHz / 44.1 KHz or less 001 = x2 010 = Reserved (x3) 011 = x4 100-111 = Reserved
[10:8]	SmplRateDiv	RW	0x0	Sample Base Rate Divisor 000 = Divide by 1 001 = Divide by 2 010 = Divide by 3 011 = Divide by 4 100 = Divide by 5 101 = Divide by 6 110 = Divide by 7 111 = Divide by 8
[7]	Rsvd1	R	0x0	Reserved

Table 118. ADC0 Cnvtr Command Response Format

Bit	Bitfield Name	RW	Reset	Description
[6:4]	BitsPerSmpl	RW	0x3	Bits per Sample 000 = 8 bits 001 = 16 bits 010 = 20 bits 011 = 24 bits 100-111 = Reserved
[3:0]	NmbrChan	RW	0x1	Number of Channels Number of channels in each frame of the stream. 0000 = 1 channel 0001 = 2 channels ... 1111 = 16 channels

6.7.2. ADC0 WCap

Table 119. ADC0 WCap Command Verb Format

	Verb ID	Payload	Response
Get	F00	09	See bitfield table.

Table 120. ADC0 WCap Command Response Format

Bit	Bitfield Name	RW	Reset	Description
[31:24]	Rsvd2	R	0x0	Reserved
[23:20]	Type	R	0x1	Widget type = Audio Input
[19:16]	Delay	R	0xD	Number of sample delays through widget
[15:12]	Rsvd1	R	0x0	Reserved
[11]	SwapCap	R	0x0	No left/right swap capability
[10]	PwrCntrl	R	0x1	Power State control is supported
[9]	Dig	R	0x0	Widget supports an Analog stream
[8]	ConnList	R	0x1	Connection list is present
[7]	UnSolCap	R	0x0	No support for Unsolicited Response
[6]	ProcWidget	R	0x1	Software should query the Processing Controls parameter for this widget.

Table 120. ADC0 WCap Command Response Format

Bit	Bitfield Name	RW	Reset	Description
[5]	Stripe	R	0x0	No support for striping
[4]	FormatOvrd	R	0x0	No format info; use default format parameters from Audio Function node instead
[3]	AmpParOvrd	R	0x0	No amplifier info; use default amplifier parameters from Audio Function node instead
[2]	OutAmpPrsnt	R	0x0	No output amp
[1]	InAmpPrsnt	R	0x0	No input amp
[0]	Stereo	R	0x1	Stereo widget

6.7.3. ADC0 ConLst

Table 121. ADC0 ConLst Command Verb Format

	Verb ID	Payload	Response
Get	F00	0E	See bitfield table.

Table 122. ADC0 ConLst Command Response Format

Bit	Bitfield Name	RW	Reset	Description
[31:8]	Rsvd	R	0x0	Reserved.
[7]	LForm	R	0x0	Connection list uses short-form (7-bit) NID entries.
[6:0]	ConL	R	0x01	Number of NID entries in connection list.

6.7.4. ADC0 ConLstEntry

Table 123. ADC0 ConLstEntry Command Verb Format

	Verb ID	Payload	Response
Get	F02	00	See bitfield table.

Table 124. ADC0 ConLstEntry Command Response Format

Bit	Bitfield Name	RW	Reset	Description
[31:24]	ConL3	R	0x00	Unused list entry.
[23:16]	ConL2	R	0x00	Unused list entry.
[15:8]	ConL1	R	0x00	Unused list entry.
[7:0]	ConL0	R	0x1B	ADC0Mux widget

6.7.5. ADC0 ProcState

Table 125. ADC0 ProcState Command Verb Format

	Verb ID	Payload	Response
Get	F03	00	See bitfield table.
Set1	703	See bits [7:0] of bitfield table.	0000_0000h

Table 126. ADC0 ProcState Command Response Format

Bit	Bitfield Name	RW	Reset	Description
[31:8]	Rsvd2	R	0x0	Reserved
[7]	HPFOCDIS	RW	0x0	High Pass Filter Offset Calculation Disable 0 = Calculation enabled. 1 = Calculation disabled.
[6:2]	Rsvd1	R	0x0	Reserved
[1:0]	ADCHPFByp	RW	0x1	Processing State = 00 (OFF): bypass the ADC high pass filter; Processing State = 01, 10, 11 (ON or BENIGN): ADC high pass filter is enabled.

6.7.6. ADC0 PwrState

Table 127. ADC0 PwrState Command Verb Format

	Verb ID	Payload	Response
Get	F05	00	See bitfield table.
Set1	705	See bits [7:0] of bitfield table.	0000_0000h

Table 128. ADC0 PwrState Command Response Format

Bit	Bitfield Name	RW	Reset	Description
[31:8]	Rsvd2	R	0x0	Reserved
[7:4]	Act	R	0x3	PS-Act: Actual power state of referenced node.
[3:2]	Rsvd1	R	0x0	Reserved
[1:0]	Set	RW	0x3	PS-Set: Current power setting of referenced node. 00 - Fully on. 01 - Fully on. 10 - Fully on. 11 - Powered down (default)

6.7.7. ADC0 CnvtrID

Table 129. ADC0 CnvtrID Command Verb Format

	Verb ID	Payload	Response
Get	F06	00	See bitfield table.
Set1	706	See bits [7:0] of bitfield table.	0000_0000h

Table 130. ADC0 CnvtrID Command Response Format

Bit	Bitfield Name	RW	Reset	Description
[31:8]	Rsvd	R	0x0	Reserved
[7:4]	Strm	RW	0x0	Software-programmable integer representing link stream ID used by the converter widget. By convention stream 0 is reserved as unused.
[3:0]	Ch	RW	0x0	Integer representing lowest channel used by converter

6.8. ADC1 Node (NID = 0x08)

6.8.1. ADC1 Cnvtr

Table 131. ADC1 Cnvtr Command Verb Format

	Verb ID	Payload	Response
Get	A	0000	See bitfield table.
Set1	2	See bits [15:0] of bitfield table.	0000_0000h

Table 132. ADC1 Cnvtr Command Response Format

Bit	Bitfield Name	RW	Reset	Description
[31:16]	Rsvd2	R	0x0	Reserved
[15]	StrmType	R	0x0	Stream Type: only PCM streams are supported by this widget.
[14]	FrmtSmplRate	RW	0x0	Sample Base Rate 0 = 48 KHz 1 = 44.1 KHz
[13:11]	SmplRateMultp	RW	0x0	Sample Base Rate Multiple 000 = 48 KHz / 44.1 KHz or less 001 = x2 010 = Reserved (x3) 011 = x4 100-111 = Reserved
[10:8]	SmplRateDiv	RW	0x0	Sample Base Rate Divisor 000 = Divide by 1 001 = Divide by 2 010 = Divide by 3 011 = Divide by 4 100 = Divide by 5 101 = Divide by 6 110 = Divide by 7 111 = Divide by 8
[7]	Rsvd1	R	0x0	Reserved

Table 132. ADC1 Cnvtr Command Response Format

Bit	Bitfield Name	RW	Reset	Description
[6:4]	BitsPerSmpl	RW	0x3	Bits per Sample 000 = 8 bits 001 = 16 bits 010 = 20 bits 011 = 24 bits 100-111 = Reserved
[3:0]	NmbrChan	RW	0x1	Number of Channels Number of channels in each frame of the stream. 0000 = 1 channel 0001 = 2 channels ... 1111 = 16 channels

6.8.2. ADC1 WCap

Table 133. ADC1 WCap Command Verb Format

	Verb ID	Payload	Response
Get	F00	09	See bitfield table.

Table 134. ADC1 WCap Command Response Format

Bit	Bitfield Name	RW	Reset	Description
[31:24]	Rsvd2	R	0x0	Reserved
[23:20]	Type	R	0x1	Widget type = Audio Input
[19:16]	Delay	R	0xD	Number of sample delays through widget
[15:12]	Rsvd1	R	0x0	Reserved
[11]	SwapCap	R	0x0	No left/right swap capability
[10]	PwrCntrl	R	0x1	Power State control is supported
[9]	Dig	R	0x0	Widget supports an Analog stream
[8]	ConnList	R	0x1	Connection list is present
[7]	UnSolCap	R	0x0	No support for Unsolicited Response
[6]	ProcWidget	R	0x1	Software should query the Processing Controls parameter for this widget.

Table 134. ADC1 WCap Command Response Format

Bit	Bitfield Name	RW	Reset	Description
[5]	Stripe	R	0x0	No support for striping
[4]	FormatOvrd	R	0x0	No format info; use default format parameters from Audio Function node instead
[3]	AmpParOvrd	R	0x0	No amplifier info; use default amplifier parameters from Audio Function node instead
[2]	OutAmpPrsnt	R	0x0	No output amp
[1]	InAmpPrsnt	R	0x0	No input amp
[0]	Stereo	R	0x1	Stereo widget

6.8.3. ADC1 ConLst

Table 135. ADC1 ConLst Command Verb Format

	Verb ID	Payload	Response
Get	F00	0E	See bitfield table.

Table 136. ADC1 ConLst Command Response Format

Bit	Bitfield Name	RW	Reset	Description
[31:8]	Rsvd	R	0x0	Reserved.
[7]	LForm	R	0x0	Connection list uses short-form (7-bit) NID entries.
[6:0]	ConL	R	0x01	Number of NID entries in connection list.

6.8.4. ADC1 ConLstEntry

Table 137. ADC1 ConLstEntry Command Verb Format

	Verb ID	Payload	Response
Get	F02	00	See bitfield table.

Table 138. ADC1 ConLstEntry Command Response Format

Bit	Bitfield Name	RW	Reset	Description
[31:24]	ConL3	R	0x00	Unused list entry.
[23:16]	ConL2	R	0x00	Unused list entry.
[15:8]	ConL1	R	0x00	Unused list entry.
[7:0]	ConL0	R	0x1C	ADC1Mux widget

6.8.5. ADC1 ProcState

Table 139. ADC1 ProcState Command Verb Format

	Verb ID	Payload	Response
Get	F03	00	See bitfield table.
Set1	703	See bits [7:0] of bitfield table.	0000_0000h

Table 140. ADC1 ProcState Command Response Format

Bit	Bitfield Name	RW	Reset	Description
[31:8]	Rsvd2	R	0x0	Reserved
[7]	HPFOCDIS	RW	0x0	High Pass Filter Offset Calculation Disable 0 = Calculation enabled. 1 = Calculation disabled.
[6:2]	Rsvd1	R	0x0	Reserved
[1:0]	ADCHPFByp	RW	0x1	Processing State = 00 (OFF): bypass the ADC high pass filter; Processing State = 01, 10, 11 (ON or BENIGN): ADC high pass filter is enabled.

6.8.6. ADC1 PwrState

Table 141. ADC1 PwrState Command Verb Format

	Verb ID	Payload	Response
Get	F05	00	See bitfield table.
Set1	705	See bits [7:0] of bitfield table.	0000_0000h

Table 142. ADC1 PwrState Command Response Format

Bit	Bitfield Name	RW	Reset	Description
[31:8]	Rsvd2	R	0x0	Reserved
[7:4]	Act	R	0x3	PS-Act: Actual power state of referenced node.
[3:2]	Rsvd1	R	0x0	Reserved
[1:0]	Set	RW	0x3	PS-Set: Current power setting of referenced node. 00 - Fully on. 01 - Fully on. 10 - Fully on. 11 - Powered down (default)

6.8.7. ADC1 CnvtrID

Table 143. ADC1 CnvtrID Command Verb Format

	Verb ID	Payload	Response
Get	F06	00	See bitfield table.
Set1	706	See bits [7:0] of bitfield table.	0000_0000h

Table 144. ADC1 CnvtrID Command Response Format

Bit	Bitfield Name	RW	Reset	Description
[31:8]	Rsvd	R	0x0	Reserved
[7:4]	Strm	RW	0x0	Software-programmable integer representing link stream ID used by the converter widget. By convention stream 0 is reserved as unused.
[3:0]	Ch	RW	0x0	Integer representing lowest channel used by converter

6.9. SPDIFOut Node (NID = 0x1E)

6.9.1. SPDIFOut Cnvtr

Table 145. SPDIFOut Cnvtr Command Verb Format

	Verb ID	Payload	Response
Get	A	0000	See bitfield table.
Set1	2	See bits [15:0] of bitfield table.	0000_0000h

Table 146. SPDIFOut Cnvtr Command Response Format

Bit	Bitfield Name	RW	Reset	Description
[31:16]	Rsvd2	R	0x0	Reserved
[15]	FrmtNonPCM	RW	0x0	Stream Type 0 = PCM 1 = Non-PCM (remaining bits in this verb have other meanings)
[14]	FrmtSmplRate	RW	0x0	Sample Base Rate 0 = 48 KHz 1 = 44.1 KHz
[13:11]	SmplRateMultp	RW	0x0	Sample Base Rate Multiple 000 = 48 KHz / 44.1 KHz or less 001 = x2 010 = Reserved (x3) 011 = x4 100-111 = Reserved
[10:8]	SmplRateDiv	RW	0x0	Sample Base Rate Divisor 000 = Divide by 1 001 = Divide by 2 010 = Divide by 3 011 = Divide by 4 100 = Divide by 5 101 = Divide by 6 110 = Divide by 7 111 = Divide by 8
[7]	Rsvd1	R	0x0	Reserved

Table 146. SPDIFOut Cnvtr Command Response Format

Bit	Bitfield Name	RW	Reset	Description
[6:4]	BitsPerSmpl	RW	0x3	Bits per Sample 000 = 8 bits 001 = 16 bits 010 = 20 bits 011 = 24 bits 100-111 = Reserved
[3:0]	NmbrChan	RW	0x1	Number of Channels Number of channels in each frame of the stream. 0000 = 1 channel 0001 = 2 channels ... 1111 = 16 channels

6.9.2. SPDIFOut WCap

Table 147. SPDIFOut WCap Command Verb Format

	Verb ID	Payload	Response
Get	F00	09	See bitfield table.

Table 148. SPDIFOut WCap Command Response Format

Bit	Bitfield Name	RW	Reset	Description
[31:24]	Rsvd2	R	0x0	Reserved
[23:20]	Type	R	0x0	Widget type = Audio Output
[19:16]	Delay	R	0x4	Number of sample delays through widget
[15:12]	Rsvd1	R	0x0	Reserved
[11]	SwapCap	R	0x0	No left/right channel swap capability
[10]	PwrCntrl	R	0x0	No support for Power State control
[9]	Dig	R	0x1	Widget supports a Digital stream
[8]	ConnList	R	0x0	No connection list is present
[7]	UnSolCap	R	0x0	No support for Unsolicited Response
[6]	ProcWidget	R	0x0	No Processing Controls parameter

Table 148. SPDIFOut WCap Command Response Format

Bit	Bitfield Name	RW	Reset	Description
[5]	Stripe	R	0x0	No support for striping
[4]	FormatOvrd	R	0x1	Widget contains format info; software should query
[3]	AmpParOvrd	R	0x0	No amplifier info; use default amplifier parameters from Audio Function node instead
[2]	OutAmpPrsnt	R	0x0	No output amp
[1]	InAmpPrsnt	R	0x0	No input amp
[0]	Stereo	R	0x1	Stereo widget

6.9.3. SPDIFOut PCM

Table 149. SPDIFOut PCM Command Verb Format

	Verb ID	Payload	Response
Get	F00	0A	See bitfield table.

Table 150. SPDIFOut PCM Command Response Format

Bit	Bitfield Name	RW	Reset	Description
[31:21]	Rsvd2	R	0x0	Reserved
[20]	B32	R	0x0	32 bit audio formats are NOT supported
[19]	B24	R	0x1	24 bit audio formats are supported
[18]	B20	R	0x1	20 bit audio formats are supported
[17]	B16	R	0x1	16 bit audio formats are supported
[16]	B8	R	0x0	8 bit audio formats are NOT supported
[15:12]	Rsvd1	R	0x0	Reserved
[11]	R12	R	0x0	384 KHz rate (8/1*48 KHz) NOT supported
[10]	R11	R	0x1	192.0 KHz rate (4/1*48 KHz) supported
[9]	R10	R	0x1	176.4 KHz rate (4/1*44.1 KHz) supported

Table 150. SPDIFOut PCM Command Response Format

Bit	Bitfield Name	RW	Reset	Description
[8]	R9	R	0x1	96.0 KHz rate (2/1*48 KHz) supported
[7]	R8	R	0x1	88.2 KHz rate (2/1*44.1 KHz) supported
[6]	R7	R	0x1	48.0 KHz rate supported (REQUIRED)
[5]	R6	R	0x1	44.1 KHz rate supported
[4]	R5	R	0x0	32.0 KHz rate (2/3*48 KHz) NOT supported
[3]	R4	R	0x0	22.05 KHz rate (1/2*44.1 KHz) NOT supported
[2]	R3	R	0x0	16.0 KHz rate (1/3*48 KHz) NOT supported
[1]	R2	R	0x0	11.025 KHz rate (1/4*44.0 KHz) NOT supported
[0]	R1	R	0x0	8.0 KHz rate (1/6*48 KHz) NOT supported

6.9.4. SPDIFOut Stream

Table 151. SPDIFOut Stream Command Verb Format

	Verb ID	Payload	Response
Get	F00	0B	See bitfield table.

Table 152. SPDIFOut Stream Command Response Format

Bit	Bitfield Name	RW	Reset	Description
[31:3]	Rsvd	R	0x0	Reserved
[2]	NonPCM	R	0x1	Non-PCM data supported.
[1]	Float32	R	0x0	No support for Float32 data.
[0]	PCM	R	0x1	PCM-formatted data supported.

6.9.5. *SPDIFOut CnvtrID*

Table 153. SPDIFOut CnvtrID Command Verb Format

	Verb ID	Payload	Response
Get	F06	00	See bitfield table.
Set1	706	See bits [7:0] of bitfield table.	0000_0000h

Table 154. SPDIFOut CnvtrID Command Response Format

Bit	Bitfield Name	RW	Reset	Description
[31:8]	Rsvd	R	0x0	Reserved
[7:4]	Strm	RW	0x0	Software-programmable integer representing link stream ID used by the converter widget. By convention stream 0 is reserved as unused.
[3:0]	Ch	RW	0x0	Integer representing lowest channel used by converter

6.9.6. *SPDIFOut DigCnvtr*

Table 155. SPDIFOut DigCnvtr Command Verb Format

	Verb ID	Payload	Response
Get	F0D	00	See bitfield table.
Set1	70D	See bits [7:0] of bitfield table.	0000_0000h
Set2	70E	See bits [7:0] of bitfield table.	0000_0000h

Table 156. SPDIFOut DigCnvtr Command Response Format

Bit	Bitfield Name	RW	Reset	Description
[31:16]	Rsvd2	R	0x0	Reserved
[15]	Rsvd1	R	0x0	Rsvd
[14:8]	CC	RW	0x00	CC[6:0] - Category Code
[7]	L	RW	0x0	L - Generation Level
[6]	PRO	RW	0x0	PRO - Professional

Table 156. SPDIFOut DigCnvtr Command Response Format

Bit	Bitfield Name	RW	Reset	Description
[5]	AUDIO	RW	0x0	/AUDIO - Non-Audio
[4]	COPY	RW	0x0	COPY - Copyright
[3]	PRE	RW	0x0	PRE - Preemphasis
[2]	VCFG	RW	0x0	VCFG - Validity Config
[1]	V	RW	0x0	V - Validity
[0]	DigEn	RW	0x0	DigEn - Digital Enable

6.10. SPDIFIn Node (NID = 0x20)

6.10.1. SPDIFIn Cnvtr

Table 157. SPDIFIn Cnvtr Command Verb Format

	Verb ID	Payload	Response
Get	A	0000	See bitfield table.
Set1	2	See bits [15:0] of bitfield table.	0000_0000h

Table 158. SPDIFIn Cnvtr Command Response Format

Bit	Bitfield Name	RW	Reset	Description
[31:16]	Rsvd2	R	0x0	Reserved
[15]	FrmtNonPCM	RW	0x0	Stream Type 0 = PCM 1 = Non-PCM (remaining bits in this verb have other meanings)
[14]	FrmtSmplRate	RW	0x0	Sample Base Rate 0 = 48 KHz 1 = 44.1 KHz
[13:11]	SmplRateMultp	RW	0x0	Sample Base Rate Multiple 000 = 48 KHz / 44.1 KHz or less 001 = x2 010 = Reserved (x3) 011 = x4 100-111 = Reserved

Table 158. SPDIFIn Cnvtr Command Response Format

Bit	Bitfield Name	RW	Reset	Description
[10:8]	SmplRateDiv	RW	0x0	Sample Base Rate Divisor 000 = Divide by 1 001 = Divide by 2 010 = Divide by 3 011 = Divide by 4 100 = Divide by 5 101 = Divide by 6 110 = Divide by 7 111 = Divide by 8
[7]	Rsvd1	R	0x0	Reserved
[6:4]	BitsPerSmpl	RW	0x3	Bits per Sample 000 = 8 bits 001 = 16 bits 010 = 20 bits 011 = 24 bits 100-111 = Reserved
[3:0]	NmbrChan	RW	0x1	Number of Channels Number of channels in each frame of the stream. 0000 = 1 channel 0001 = 2 channels ... 1111 = 16 channels

6.10.2. SPDIFIn WCap

Table 159. SPDIFIn WCap Command Verb Format

	Verb ID	Payload	Response
Get	F00	09	See bitfield table.

Table 160. SPDIFIn WCap Command Response Format

Bit	Bitfield Name	RW	Reset	Description
[31:24]	Rsvd2	R	0x0	Reserved
[23:20]	Type	R	0x1 = Enabled 0xF = Disabled	Widget type = Audio Input
[19:16]	Delay	R	0x4	Number of sample delays through widget
[15:12]	Rsvd1	R	0x0	Reserved

Table 160. SPDIFIn WCap Command Response Format

Bit	Bitfield Name	RW	Reset	Description
[11]	SwapCap	R	0x0	No left/right channel swap capability
[10]	PwrCntrl	R	0x0	No support for Power State control
[9]	Dig	R	0x1	Widget supports a Digital stream
[8]	ConnList	R	0x1	Connection list is present
[7]	UnSolCap	R	0x0	Unsolicited Response is not supported
[6]	ProcWidget	R	0x0	No Processing Controls parameter
[5]	Stripe	R	0x0	No support for striping
[4]	FormatOvrd	R	0x1	Widget contains format info; software should query
[3]	AmpParOvrd	R	0x0	No amplifier info; use default amplifier parameters from Audio Function node instead
[2]	OutAmpPrsnt	R	0x0	No output amp
[1]	InAmpPrsnt	R	0x0	No input amp
[0]	Stereo	R	0x1	Stereo widget

6.10.3. SPDIFIn PCMCap

Table 161. SPDIFIn PCMCap Command Verb Format

	Verb ID	Payload	Response
Get	F00	0A	See bitfield table.

Table 162. SPDIFIn PCMCap Command Response Format

Bit	Bitfield Name	RW	Reset	Description
[31:21]	Rsvd2	R	0x0	Reserved
[20]	B32	R	0x0	32 bit audio formats are NOT supported
[19]	B24	R	0x1	24 bit audio formats are supported
[18]	B20	R	0x1	20 bit audio formats are supported

Table 162. SPDIFIn PCMCap Command Response Format

Bit	Bitfield Name	RW	Reset	Description
[17]	B16	R	0x1	16 bit audio formats are supported
[16]	B8	R	0x0	8 bit audio formats are NOT supported
[15:12]	Rsvd1	R	0x0	Reserved
[11]	R12	R	0x0	384 KHz rate (8/1*48 KHz) NOT supported
[10]	R11	R	0x0	192.0 KHz rate (4/1*48 KHz) NOT supported
[9]	R10	R	0x0	176.4 KHz rate (4/1*44.1 KHz) NOT supported
[8]	R9	R	0x1	96.0 KHz rate (2/1*48 KHz) supported
[7]	R8	R	0x0	88.2 KHz rate (2/1*44.1 KHz) NOT supported
[6]	R7	R	0x1	48.0 KHz rate supported (REQUIRED)
[5]	R6	R	0x1	44.1 KHz rate supported
[4]	R5	R	0x0	32.0 KHz rate (2/3*48 KHz) NOT supported
[3]	R4	R	0x0	22.05 KHz rate (1/2*44.1 KHz) NOT supported
[2]	R3	R	0x0	16.0 KHz rate (1/3*48 KHz) NOT supported
[1]	R2	R	0x0	11.025 KHz rate (1/4*44.0 KHz) NOT supported
[0]	R1	R	0x0	8.0 KHz rate (1/6*48 KHz) NOT supported

6.10.4. SPDIFIn Stream

Table 163. SPDIFIn Stream Command Verb Format

	Verb ID	Payload	Response
Get	F00	0B	See bitfield table.

Table 164. SPDIFIn Stream Command Response Format

Bit	Bitfield Name	RW	Reset	Description
[31:3]	Rsvd	R	0x0	Reserved
[2]	NonPCM	R	0x1	Non-PCM data supported.

Table 164. SPDIFIn Stream Command Response Format

Bit	Bitfield Name	RW	Reset	Description
[1]	Float32	R	0x0	No support for Float32 data.
[0]	PCM	R	0x1	PCM-formatted data supported.

6.10.5. SPDIFIn ConLst

Table 165. SPDIFIn ConLst Command Verb Format

	Verb ID	Payload	Response
Get	F00	0E	See bitfield table.

Table 166. SPDIFIn ConLst Command Response Format

Bit	Bitfield Name	RW	Reset	Description
[31:8]	Rsvd	R	0x0	Reserved.
[7]	LForm	R	0x0	Connection list uses short-form (7-bit) NID entries.
[6:0]	ConL	R	0x01	Number of NID entries in connection list.

6.10.6. SPDIFIn ConLstEntry

Table 167. SPDIFIn ConLstEntry Command Verb Format

	Verb ID	Payload	Response
Get	F02	00	See bitfield table.

Table 168. SPDIFIn ConLstEntry Command Response Format

Bit	Bitfield Name	RW	Reset	Description
[31:24]	ConL3	R	0x00	Unused list entry.
[23:16]	ConL2	R	0x00	Unused list entry.
[15:8]	ConL1	R	0x00	Unused list entry.
[7:0]	ConL0	R	0x22	DigIn pin widget

6.10.7. SPDIFIn CnvtrID

Table 169. SPDIFIn CnvtrID Command Verb Format

	Verb ID	Payload	Response
Get	F06	00	See bitfield table.
Set1	706	See bits [7:0] of bitfield table.	0000_0000h

Table 170. SPDIFIn CnvtrID Command Response Format

Bit	Bitfield Name	RW	Reset	Description
[31:8]	Rsvd	R	0x0	Reserved
[7:4]	Strm	RW	0x0	Software-programmable integer representing link stream ID used by the converter widget. By convention stream 0 is reserved as unused.
[3:0]	Ch	RW	0x0	Integer representing lowest channel used by converter

6.10.8. SPDIFIn DigCnvtr

Table 171. SPDIFIn DigCnvtr Command Verb Format

	Verb ID	Payload	Response
Get	F0D	00	See bitfield table.
Set1	70D	See bits [7:0] of bitfield table.	0000_0000h
Set2	70E	See bits [7:0] of bitfield table.	0000_0000h

Table 172. SPDIFIn DigCnvtr Command Response Format

Bit	Bitfield Name	RW	Reset	Description
[31:15]	Rsvd2	R	0x0	Reserved
[14:8]	CC	R	0x00	CC[6:0] - Category Code
[7]	L	R	0x0	L - Generation Level
[6]	PRO	R	0x0	PRO - Professional
[5]	AUDIO	R	0x0	/AUDIO - Non-Audio

Table 172. SPDIFIn DigCnvtr Command Response Format

Bit	Bitfield Name	RW	Reset	Description
[4]	COPY	R	0x0	COPY - Copyright
[3]	PRE	R	0x0	PRE - Preemphasis
[2]	Rsvd1	R	0x0	Reserved (VCFG bit applies only to output streams)
[1]	V	R	0x0	V - Validity
[0]	DigEn	RW	0x0	DigEn - Digital Enable

6.10.9. SPDIFIn VCSR0

Table 173. SPDIFIn VCSR0 Command Verb Format

	Verb ID	Payload	Response
Get	FE0	00	See bitfield table.
Set1	7E0	See bits [7:0] of bitfield table.	0000_0000h

Table 174. SPDIFIn VCSR0 Command Response Format

Bit	Bitfield Name	RW	Reset	Description
[31]	RcvSmpIRate	R	0x0	Recovered sample rate base 0 = 48 KHz 1 = 44.1 KHz
[30:28]	RcvRateMult	R	0x0	Recovered sample rate multiplier 000 = 1X 001 = 2X, all others reserved
[27:26]	Rsvd	R	0x0	Reserved
[25:22]	OrigFS	R	0x0	Original sample rate (IEC spec).
[21:20]	CA	R	0x0	Clock accuracy 00 = Level II 01 = Level I 10 = Level III 11 = Reserved

Table 174. SPDIFIn VCSR0 Command Response Format

Bit	Bitfield Name	RW	Reset	Description
[19:16]	FS	R	0x0	Sample Rate 0000 = 44.1 KHz 0010 = 48 KHz 0011 = 32 KHz All other combinations are reserved and shall not be used until further defined (IEC spec).
[15:12]	CN	R	0x0	Channel Number (audio channel) 0000 = do not take into account 0001 = A (left channel for stereo channel format) 0010 = B (right channel for stereo channel format) 0011 = C 1111 = O
[11:9]	SmpWrdL	R	0x0	Sample Word Length [2:0] If MaxWrdL = 1: 000 = unspecified 001 = 20 bits 010 = 22 bits 011 = reserved 100 = 23 bits 101 = 24 bits 110 = 21 bits 111 = reserved If MaxWrdL = 0: 000 = unspecified 001 = 16 bits 010 = 18 bits 011 = reserved 100 = 19 bits 101 = 20 bits 110 = 17 bits 111 = reserved
[8]	MaxWrdL	R	0x0	Max Word Length 0 = maximum audio sample word length is 20 bits 1 = maximum audio sample word length is 24 bits
[7]	NOBLKCH	RW	0x0	0 = normal behavior 1 = disable block size checking for spdif_in.
[6]	VI	RW	0x0	0 = Respond to SPDIF_IN Valid tag 1 = Ignore SPDIF_IN valid tag

Table 174. SPDIFIn VCSR0 Command Response Format

Bit	Bitfield Name	RW	Reset	Description
[5]	AMuteDis	RW	0x0	0 = Auto mute when SPDIF stream marked non PCM 1 = Auto Mute disabled.
[4:3]	SPL	RW	0x0	SPDIF_IN Parity Limit: Loss of DPLL Lock after 00 = 4 parity errors 01 = 3 parity errors 10 = 2 parity errors 11 = 1 parity errors NEW LOCATION -- was at Register 72h, Page 0, D13:12, moved as part of SPDIF In consolidation
[2]	SPRun	R	0x0	SPDIF IN Running 0 = no signal on pin 47 1 = signal on pin 47 NEW LOCATION -- was at Register 72h, Page 0, D2, moved as part of SPDIF In consolidation
[1]	SIPER	RW	0x0	SPDIF_IN PARITY ERROR. Set to clear. Overlaps SIPERSTAT.
[0]	COPYINV	RW	0x0	Copyright invert bit.

6.11. PortA Node (NID = 0x0A)

6.11.1. PortA WCap

Table 175. PortA WCap Command Verb Format

	Verb ID	Payload	Response
Get	F00	09	See bitfield table.

Table 176. PortA WCap Command Response Format

Bit	Bitfield Name	RW	Reset	Description
[31:24]	Rsvd2	R	0x0	Reserved
[23:20]	Type	R	0x4	Widget type = Pin Complex
[19:16]	Delay	R	0x0	Number of sample delays through widget

Table 176. PortA WCap Command Response Format

Bit	Bitfield Name	RW	Reset	Description
[15:12]	Rsvd1	R	0x0	Reserved
[11]	SwapCap	R	0x0	No left/right channel swap capability
[10]	PwrCntrl	R	0x0	No support for Power State control
[9]	Dig	R	0x0	Widget supports an Analog stream
[8]	ConnList	R	0x1	Connection list is present
[7]	UnSolCap	R	0x1	Unsolicited Response is supported
[6]	ProcWidget	R	0x0	No Processing Controls parameter
[5]	Stripe	R	0x0	No support for striping
[4]	FormatOvrd	R	0x0	N/A for pin complex
[3]	AmpParOvrd	R	0x0	No amplifier info; use default amplifier parameters from Audio Function node instead
[2]	OutAmpPrsnt	R	0x0	No output amp
[1]	InAmpPrsnt	R	0x0	No input amp
[0]	Stereo	R	0x1	Stereo widget

6.11.2. PortA PinCap

Table 177. PortA PinCap Command Verb Format

	Verb ID	Payload	Response
Get	F00	0C	See bitfield table.

Table 178. PortA PinCap Command Response Format

Bit	Bitfield Name	RW	Reset	Description
[31:17]	Rsvd2	R	0x0	Reserved
[16]	EapdCap	R	0x0	This widget does not control EAPD pin

Table 178. PortA PinCap Command Response Format

Bit	Bitfield Name	RW	Reset	Description
[15:8]	VrefCntrl	R	0x17	VRef generation is supported by this pin complex, and the following voltages can be produced on the associated VRef pin: 80% Avdd; 50% Avdd; GND; Hi-Z (required since pin complex is output capable)
[7]	Rsvd1	R	0x0	Reserved
[6]	BalancedIO	R	0x0	Pin complex does not have balanced pins.
[5]	InCap	R	0x1	Pin complex is input capable.
[4]	OutCap	R	0x1	Pin complex is output capable.
[3]	HdphDrvCap	R	0x1	Pin complex has headphone amplifier.
[2]	PresDtctCap	R	0x1	Pin complex can perform Presence Detect.
[1]	TrigRqd	R	0x1	Trigger is required for impedance measurement
[0]	ImpSenseCap	R	0x1	Pin complex supports impedance sense.

6.11.3. PortA ConLst

Table 179. PortA ConLst Command Verb Format

	Verb ID	Payload	Response
Get	F00	0E	See bitfield table.

Table 180. PortA ConLst Command Response Format

Bit	Bitfield Name	RW	Reset	Description
[31:8]	Rsvd	R	0x0	Reserved
[7]	LForm	R	0x0	Connection list uses short-form (7-bit) NID entries.
[6:0]	ConL	R	0x03 = Enabled 0x02 = Disabled	Number of NID entries in connection list.

6.11.4. PortA ConLstEntry

Table 181. PortA ConLstEntry Command Verb Format

	Verb ID	Payload	Response
Get	F02	00	See bitfield table.

Table 182. PortA ConLstEntry Command Response Format

Bit	Bitfield Name	RW	Reset	Description
[31:24]	ConL3	R	0x00	Unused list entry.
[23:16]	ConL2	R	0x06 = Enabled 0x00 = Disabled	DAC4 Converter widget
[15:8]	ConL1	R	0x03	DAC1 Converter widget
[7:0]	ConL0	R	0x02	DAC0 Converter widget

6.11.5. PortA ConSelectCtrl

Table 183. PortA ConSelectCtrl Command Verb Format

	Verb ID	Payload	Response
Get	F01	00	See bitfield table.
Set1	701	See bits [7:0] of bitfield table.	0000_0000h

Table 184. PortA ConSelectCtrl Command Response Format

Bit	Bitfield Name	RW	Reset	Description
[31:2]	Rsvd	R	0x0	Reserved
[1:0]	Index	RW	0x0	Connection select control index.

6.11.6. PortA PinWCntrl

Table 185. PortA PinWCntrl Command Verb Format

	Verb ID	Payload	Response
Get	F07	00	See bitfield table.
Set1	707	See bits [7:0] of bitfield table.	0000_0000h

Table 186. PortA PinWCntrl Command Response Format

Bit	Bitfield Name	RW	Reset	Description
[31:8]	Rsvd2	R	0x0	Reserved
[7]	HPHnEn	RW	0x0	1 = enable the low impedance amplifier associated with the output.
[6]	OutEn	RW	0x0	1 = (CODEC) output path of Pin Widget is enabled
[5]	InEn	RW	0x0	1 = (CODEC) input path of Pin Widget is enabled
[4:3]	Rsvd1	R	0x0	Reserved
[2:0]	VRefEn	RW	0x0	VRefEn: Selects one of the possible states for the VRef signal associated with the Pin Widget. If the value written to this control does not correspond to a supported value defined in the VRefCntrl field of the Pin Capabilities parameter (0C), then this control will take the value of 000b (Hi-Z).

6.11.7. PortA Unsolicited Response

Table 187. PortA Unsolicited Response Command Verb Format

	Verb ID	Payload	Response
Get	F08	00	See bitfield table.
Set1	708	See bits [7:0] of bitfield table.	0000_0000h

Table 188. PortA Unsolicited Response Command Response Format

Bit	Bitfield Name	RW	Reset	Description
[31:8]	Rsvd2	R	0x00	Reserved
[7]	En	RW	0x0	Allow generation of Unsolicited Responses. Unsolicited response events occur upon jack-insertion OR completion of a Jack-Sense cycle.
[6]	Rsvd1	R	0x0	Reserved
[5:0]	Tag	RW	0x00	Software programmable field returned in top six bits (31:26) of every Unsolicited Response generated by this node.

6.11.8. PortA ChSense

Table 189. PortA ChSense Command Verb Format

	Verb ID	Payload	Response
Get	F09	00	See bitfield table.
Set1	709	See bits [7:0] of bitfield table.	0000_0000h
Set2	709	See bits [7:0] of bitfield table.	0000_0000h

Table 190. PortA ChSense Command Response Format

Bit	Bitfield Name	RW	Reset	Description
[31]	PresDtct	R	0x0	1 = something is plugged into jack associated with Pin Complex.
[30:0]	Impedance	R	0x7FFF_FFFF	Measured impedance of the widget. A value of all 1s indicates that a valid sense reading is not available, or the sense measurement is busy if it has been recently triggered.
[0]	RightCh	W	0x0	Set 1 = perform impedance sensing on right channel or ring of the connector
[0]	LeftCh	W	0x0	Set 0 = perform impedance sensing on left channel or tip of the connector

6.11.9. PortA ConfigDefault

Table 191. PortA ConfigDefault Command Verb Format

	Verb ID	Payload	Response
Get	F1C	00	See bitfield table.
Set1	71C	See bits [7:0] of bitfield table.	0000_0000h
Set2	71D	See bits [7:0] of bitfield table.	0000_0000h
Set3	71E	See bits [7:0] of bitfield table.	0000_0000h
Set4	71F	See bits [7:0] of bitfield table.	0000_0000h

Table 192. PortA ConfigDefault Command Response Format

Bit	Bitfield Name	RW	Reset	Description
[31:24]	Config4	RW	0x02	Port Connectivity = Jack; Location = Mainboard front.
[23:16]	Config3	RW	0x21	Default Device = HP Out; Connection Type = 1/8 inch jack.
[15:8]	Config2	RW	0x40	Color = Green; Misc = No jack detect override.
[7:0]	Config1	RW	0x20	Association = 2h; Sequence = 0h.

6.12. PortB Node (NID = 0x0B)

6.12.1. PortB WCap

Table 193. PortB WCap Command Verb Format

	Verb ID	Payload	Response
Get	F00	09	See bitfield table.

Table 194. PortB WCap Command Response Format

Bit	Bitfield Name	RW	Reset	Description
[31:24]	Rsvd2	R	0x0	Reserved
[23:20]	Type	R	0x4	Widget type = Pin Complex
[19:16]	Delay	R	0x0	Number of sample delays through widget
[15:12]	Rsvd1	R	0x0	Reserved
[11]	SwapCap	R	0x0	No left/right channel swap capability
[10]	PwrCntrl	R	0x0	No support for Power State control
[9]	Dig	R	0x0	Widget supports an Analog stream
[8]	ConnList	R	0x1	Connection list is present
[7]	UnSolCap	R	0x1	Unsolicited Response is supported

Table 194. PortB WCap Command Response Format

Bit	Bitfield Name	RW	Reset	Description
[6]	ProcWidget	R	0x0	No Processing Controls parameter
[5]	Stripe	R	0x0	No support for striping
[4]	FormatOvrd	R	0x0	N/A for pin complex
[3]	AmpParOvrd	R	0x0	No amplifier info; use default amplifier parameters from Audio Function node instead
[2]	OutAmpPrsnt	R	0x0	No output amp
[1]	InAmpPrsnt	R	0x0	No input amp
[0]	Stereo	R	0x1	Stereo widget

6.12.2. PortB PinCap

Table 195. PortB PinCap Command Verb Format

	Verb ID	Payload	Response
Get	F00	0C	See bitfield table.

Table 196. PortB PinCap Command Response Format

Bit	Bitfield Name	RW	Reset	Description
[31:17]	Rsvd2	R	0x0	Reserved
[16]	EapdCap	R	0x0	This widget does not control EAPD pin
[15:8]	VrefCntrl	R	0x17	VRef generation is supported by this pin complex, and the following voltages can be produced on the associated VRef pin: 80% Avdd; 50%Avdd; GND; Hi-Z (required since pin complex is output capable)
[7]	Rsvd1	R	0x0	Reserved
[6]	BalancedIO	R	0x0	Pin complex does not have balanced pins.
[5]	InCap	R	0x1	Pin complex is input capable.
[4]	OutCap	R	0x1	Pin complex is output capable.

Table 196. PortB PinCap Command Response Format

Bit	Bitfield Name	RW	Reset	Description
[3]	HdphDrvCap	R	0x1	Pin has a headphone amplifier.
[2]	PresDtctCap	R	0x1	Pin complex can perform Presence Detect.
[1]	TrigRqd	R	0x1	Trigger is required for impedance measurement
[0]	ImpSenseCap	R	0x1	Pin complex supports impedance sense.

6.12.3. PortB ConLst

Table 197. PortB ConLst Command Verb Format

	Verb ID	Payload	Response
Get	F00	0E	See bitfield table.

Table 198. PortB ConLst Command Response Format

Bit	Bitfield Name	RW	Reset	Description
[31:8]	Rsvd	R	0x0	Reserved
[7]	LForm	R	0x0	Connection list uses short-form (7-bit) NID entries.
[6:0]	ConL	R	0x03 = Enabled DAC4 0x02 = Disabled DAC4	Number of NID entries in connection list.

6.12.4. PortB ConLstEntry

Table 199. PortB ConLstEntry Command Verb Format

	Verb ID	Payload	Response
Get	F02	00	See bitfield table.

Table 200. PortB ConLstEntry Command Response Format

Bit	Bitfield Name	RW	Reset	Description
[31:24]	ConL3	R	0x00	Unused list entry.
[23:16]	ConL2	R	0x06 = Enabled 0x00 = Disabled	DAC4 Converter widget

Table 200. PortB ConLstEntry Command Response Format

Bit	Bitfield Name	RW	Reset	Description
[15:8]	ConL1	R	0x03	DAC1 Converter widget
[7:0]	ConL0	R	0x02	DAC0 Converter widget

6.12.5. PortB ConSelectCtrl

Table 201. PortB ConSelectCtrl Command Verb Format

	Verb ID	Payload	Response
Get	F01	00	See bitfield table.
Set1	701	See bits [7:0] of bitfield table.	0000_0000h

Table 202. PortB ConSelectCtrl Command Response Format

Bit	Bitfield Name	RW	Reset	Description
[31:2]	Rsvd	R	0x0	Reserved
[1:0]	Index	RW	0x0	Connection select control index.

6.12.6. PortB PinWCntrl

Table 203. PortB PinWCntrl Command Verb Format

	Verb ID	Payload	Response
Get	F07	00	See bitfield table.
Set1	707	See bits [7:0] of bitfield table.	0000_0000h

Table 204. PortB PinWCntrl Command Response Format

Bit	Bitfield Name	RW	Reset	Description
[31:8]	Rsvd2	R	0x0	Reserved
[7]	HPhnEn	RW	0x0	1 = enable the low impedance amplifier associated with the output.
[6]	OutEn	RW	0x0	1 = (CODEC) output path of Pin Widget is enabled

Table 204. PortB PinWCntrl Command Response Format

Bit	Bitfield Name	RW	Reset	Description
[5]	InEn	RW	0x0	1 = (CODEC) input path of Pin Widget is enabled
[4:3]	Rsvd1	R	0x0	Reserved
[2:0]	VRefEn	RW	0x0	VRefEn: Selects one of the possible states for the VRef signal associated with the Pin Widget. If the value written to this control does not correspond to a supported value defined in the VRefCntrl field of the Pin Capabilities parameter (0C), then this control will take the value of 000b (Hi-Z).

6.12.7. PortB Unsolicited Response

Table 205. PortB Unsolicited Response Command Verb Format

	Verb ID	Payload	Response
Get	F08	00	See bitfield table.
Set1	708	See bits [7:0] of bitfield table.	0000_0000h

Table 206. PortB Unsolicited Response Command Response Format

Bit	Bitfield Name	RW	Reset	Description
[31:8]	Rsvd2	R	0x00	Reserved
[7]	En	RW	0x0	Allow generation of Unsolicited Responses. Unsolicited response events occur upon jack-insertion OR completion of a Jack-Sense cycle.
[6]	Rsvd1	R	0x0	Reserved
[5:0]	Tag	RW	0x00	Software programmable field returned in top six bits (31:26) of every Unsolicited Response generated by this node.

6.12.8. PortB ChSense

Table 207. PortB ChSense Command Verb Format

	Verb ID	Payload	Response
Get	F09	00	See bitfield table.
Set1	709	See bits [7:0] of bitfield table.	0000_0000h
Set2	709	See bits [7:0] of bitfield table.	0000_0000h

Table 208. PortB ChSense Command Response Format

Bit	Bitfield Name	RW	Reset	Description
[31]	PresDtct	R	0x0	1 = something is plugged into jack associated with Pin Complex.
[30:0]	Impedance	R	0x7FFF_FFFF	Measured impedance of the widget. A value of all 1s indicates that a valid sense reading is not available, or the sense measurement is busy if it has been recently triggered.
[0]	RightCh	W	0x0	Set 1 = perform impedance sensing on right channel or ring of the connector
[0]	LeftCh	W	0x0	Set 0 = perform impedance sensing on left channel or tip of the connector

6.12.9. PortB ConfigDefault

Table 209. PortB ConfigDefault Command Verb Format

	Verb ID	Payload	Response
Get	F1C	00	See bitfield table.
Set1	71C	See bits [7:0] of bitfield table.	0000_0000h
Set2	71D	See bits [7:0] of bitfield table.	0000_0000h
Set3	71E	See bits [7:0] of bitfield table.	0000_0000h
Set4	71F	See bits [7:0] of bitfield table.	0000_0000h

Table 210. PortB ConfigDefault Command Response Format

Bit	Bitfield Name	RW	Reset	Description
[31:24]	Config4	RW	0x02	Port Connectivity = Jack; Location = Mainboard front.
[23:16]	Config3	RW	0xA1	Default Device = Mic In; Connection Type = 1/8 inch jack.
[15:8]	Config2	RW	0x90	Color = Pink; Misc = No jack detect override.
[7:0]	Config1	RW	0x80	Association = 8h; Sequence = 0h.

6.13. PortC Node (NID = 0x0C)

6.13.1. PortC WCap

Table 211. PortC WCap Command Verb Format

	Verb ID	Payload	Response
Get	F00	09	See bitfield table.

Table 212. PortC WCap Command Response Format

Bit	Bitfield Name	RW	Reset	Description
[31:24]	Rsvd2	R	0x0	Reserved
[23:20]	Type	R	0x4	Widget type = Pin Complex
[19:16]	Delay	R	0x0	Number of sample delays through widget
[15:12]	Rsvd1	R	0x0	Reserved
[11]	SwapCap	R	0x0	No left/right channel swap capability
[10]	PwrCntrl	R	0x0	No support for Power State control
[9]	Dig	R	0x0	Widget supports an Analog stream
[8]	ConnList	R	0x1	Connection list is present
[7]	UnSolCap	R	0x1	Unsolicited Response is supported

Table 212. PortC WCap Command Response Format

Bit	Bitfield Name	RW	Reset	Description
[6]	ProcWidget	R	0x0	No Processing Controls parameter
[5]	Stripe	R	0x0	No support for striping
[4]	FormatOvrd	R	0x0	N/A for pin complex
[3]	AmpParOvrd	R	0x0	No amplifier info; use default amplifier parameters from Audio Function node instead
[2]	OutAmpPrsnt	R	0x0	No output amp
[1]	InAmpPrsnt	R	0x0	No input amp
[0]	Stereo	R	0x1	Stereo widget

6.13.2. PortC PinCap

Table 213. PortC PinCap Command Verb Format

	Verb ID	Payload	Response
Get	F00	0C	See bitfield table.

Table 214. PortC PinCap Command Response Format

Bit	Bitfield Name	RW	Reset	Description
[31:17]	Rsvd2	R	0x0	Reserved
[16]	EapdCap	R	0x0	This widget does not control EAPD pin
[15:8]	VrefCntrl	R	0x17	VRef generation is supported by this pin complex, and the following voltages can be produced on the associated VRef pin: 80% Avdd; 50% Avdd; GND; Hi-Z (required since pin complex is output capable)
[7]	Rsvd1	R	0x0	Reserved
[6]	BalancedIO	R	0x0	Pin complex does not have balanced pins.
[5]	InCap	R	0x1	Pin complex is input capable.
[4]	OutCap	R	0x1	Pin complex is output capable.

Table 214. PortC PinCap Command Response Format

Bit	Bitfield Name	RW	Reset	Description
[3]	HdphDrvCap	R	0x0	Pin does not have a headphone amplifier.
[2]	PresDtctCap	R	0x1	Pin complex can perform Presence Detect.
[1]	TrigRqd	R	0x1	Trigger is required for impedance measurement
[0]	ImpSenseCap	R	0x1	Pin complex supports impedance sense.

6.13.3. PortC ConLst

Table 215. PortC ConLst Command Verb Format

	Verb ID	Payload	Response
Get	F00	0E	See bitfield table.

Table 216. PortC ConLst Command Response Format

Bit	Bitfield Name	RW	Reset	Description
[31:8]	Rsvd	R	0x0	Reserved
[7]	LForm	R	0x0	Connection list uses short-form (7-bit) NID entries.
[6:0]	ConL	R	0x01	Number of NID entries in connection list.

6.13.4. PortC ConLstEntry

Table 217. PortC ConLstEntry Command Verb Format

	Verb ID	Payload	Response
Get	F02	00	See bitfield table.

Table 218. PortC ConLstEntry Command Response Format

Bit	Bitfield Name	RW	Reset	Description
[31:24]	ConL3	R	0x00	Unused list entry.
[23:16]	ConL2	R	0x00	Unused list entry.

Table 218. PortC ConLstEntry Command Response Format

Bit	Bitfield Name	RW	Reset	Description
[15:8]	ConL1	R	0x00	Unused list entry.
[7:0]	ConL0	R	0x03	DAC1 Converter widget

6.13.5. PortC PinWCntrl

Table 219. PortC PinWCntrl Command Verb Format

	Verb ID	Payload	Response
Get	F07	00	See bitfield table.
Set1	707	See bits [7:0] of bitfield table.	0000_0000h

Table 220. PortC PinWCntrl Command Response Format

Bit	Bitfield Name	RW	Reset	Description
[31:7]	Rsvd2	R	0x0	Reserved
[6]	OutEn	RW	0x0	1 = (CODEC) output path of Pin Widget is enabled
[5]	InEn	RW	0x0	1 = (CODEC) input path of Pin Widget is enabled
[4:3]	Rsvd1	R	0x0	Reserved
[2:0]	VRefEn	RW	0x0	VRefEn: Selects one of the possible states for the VRef signal associated with the Pin Widget. If the value written to this control does not correspond to a supported value defined in the VRefCntrl field of the Pin Capabilities parameter (0C), then this control will take the value of 000b (Hi-Z).

6.13.6. PortC UnsolResp

Table 221. PortC UnsolResp Command Verb Format

	Verb ID	Payload	Response
Get	F08	00	See bitfield table.
Set1	708	See bits [7:0] of bitfield table.	0000_0000h

Table 222. PortC UnsolResp Command Response Format

Bit	Bitfield Name	RW	Reset	Description
[31:8]	Rsvd2	R	0x00	Reserved
[7]	En	RW	0x0	Allow generation of Unsolicited Responses. Unsolicited response events occur upon jack-insertion OR completion of a Jack-Sense cycle.
[6]	Rsvd1	R	0x0	Reserved
[5:0]	Tag	RW	0x00	Software programmable field returned in top six bits (31:26) of every Unsolicited Response generated by this node.

6.13.7. PortC ChSense

Table 223. PortC ChSense Command Verb Format

	Verb ID	Payload	Response
Get	F09	00	See bitfield table.
Set1	709	See bits [7:0] of bitfield table.	0000_0000h
Set2	709	See bits [7:0] of bitfield table.	0000_0000h

Table 224. PortC ChSense Command Response Format

Bit	Bitfield Name	RW	Reset	Description
[31]	PresDtct	R	0x0	1 = something is plugged into jack associated with Pin Complex.
[30:0]	Impedance	R	0x7FFF_FFFF	Measured impedance of the widget. A value of all 1s indicates that a valid sense reading is not available, or the sense measurement is busy if it has been recently triggered.
[0]	RightCh	W	0x0	Set 1 = perform impedance sensing on right channel or ring of the connector
[0]	LeftCh	W	0x0	Set 0 = perform impedance sensing on left channel or tip of the connector

6.13.8. PortC ConfigDefault

Table 225. PortC ConfigDefault Command Verb Format

	Verb ID	Payload	Response
Get	F1C	00	See bitfield table.
Set1	71C	See bits [7:0] of bitfield table.	0000_0000h
Set2	71D	See bits [7:0] of bitfield table.	0000_0000h
Set3	71E	See bits [7:0] of bitfield table.	0000_0000h
Set4	71F	See bits [7:0] of bitfield table.	0000_0000h

Table 226. PortC ConfigDefault Command Response Format

Bit	Bitfield Name	RW	Reset	Description
[31:24]	Config4	RW	0x01	Port Connectivity = Jack; Location = Mainboard rear.
[23:16]	Config3	RW	0x81	Default Device = Line In; Connection Type = 1/8 inch jack.
[15:8]	Config2	RW	0x30	Color = Blue; Misc = No jack detect override.
[7:0]	Config1	RW	0x4E	Association = 4h; Sequence = Eh.

6.14. PortD Node (NID = 0x0D)

6.14.1. PortD WCap

Table 227. PortD WCap Command Verb Format

	Verb ID	Payload	Response
Get	F00	09	See bitfield table.

Table 228. PortD WCap Command Response Format

Bit	Bitfield Name	RW	Reset	Description
[31:24]	Rsvd2	R	0x0	Reserved
[23:20]	Type	R	0x4	Widget type = Pin Complex

Table 228. PortD WCap Command Response Format

Bit	Bitfield Name	RW	Reset	Description
[19:16]	Delay	R	0x0	Number of sample delays through widget
[15:12]	Rsvd1	R	0x0	Reserved
[11]	SwapCap	R	0x0	No left/right channel swap capability
[10]	PwrCntrl	R	0x0	No support for Power State control
[9]	Dig	R	0x0	Widget supports an Analog stream
[8]	ConnList	R	0x1	Connection list is present
[7]	UnSolCap	R	0x1	Unsolicited Response is supported
[6]	ProcWidget	R	0x0	No Processing Controls parameter
[5]	Stripe	R	0x0	No support for striping
[4]	FormatOvrd	R	0x0	N/A for pin complex
[3]	AmpParOvrd	R	0x0	No amplifier info; use default amplifier parameters from Audio Function node instead
[2]	OutAmpPrsnt	R	0x0	No output amp
[1]	InAmpPrsnt	R	0x0	No input amp
[0]	Stereo	R	0x1	Stereo widget

6.14.2. PortD PinCap

Table 229. PortD PinCap Command Verb Format

	Verb ID	Payload	Response
Get	F00	0C	See bitfield table.

Table 230. PortD PinCap Command Response Format

Bit	Bitfield Name	RW	Reset	Description
[31:17]	Rsvd2	R	0x0	Reserved
[16]	EapdCap	R	0x0	This widget does not control EAPD pin

Table 230. PortD PinCap Command Response Format

Bit	Bitfield Name	RW	Reset	Description
[15:8]	VrefCntrl	R	0x17	VRef generation is supported by this pin complex, and the following voltages can be produced on the associated VRef pin: 80% Avdd; 50% Avdd; GND; Hi-Z (required since pin complex is output capable)
[7]	Rsvd1	R	0x0	Reserved
[6]	BalancedIO	R	0x0	Pin complex does not have balanced pins.
[5]	InCap	R	0x1	Pin complex is input capable.
[4]	OutCap	R	0x1	Pin complex is output capable.
[3]	HdphDrvCap	R	0x1	Pin complex has headphone amplifier.
[2]	PresDtctCap	R	0x1	Pin complex can perform Presence Detect.
[1]	TrigRqd	R	0x1	Trigger is required for impedance measurement
[0]	ImpSenseCap	R	0x1	Pin complex supports impedance sense.

6.14.3. PortD ConLst

Table 231. PortD ConLst Command Verb Format

	Verb ID	Payload	Response
Get	F00	0E	See bitfield table.

Table 232. PortD ConLst Command Response Format

Bit	Bitfield Name	RW	Reset	Description
[31:8]	Rsvd	R	0x0	Reserved
[7]	LForm	R	0x0	Connection list uses short-form (7-bit) NID entries.
[6:0]	ConL	R	0x01	Number of NID entries in connection list.

6.14.4. PortD ConLstEntry

Table 233. PortD ConLstEntry Command Verb Format

	Verb ID	Payload	Response
Get	F02	00	See bitfield table.

Table 234. PortD ConLstEntry Command Response Format

Bit	Bitfield Name	RW	Reset	Description
[31:24]	ConL3	R	0x00	Unused list entry.
[23:16]	ConL2	R	0x00	Unused list entry.
[15:8]	ConL1	R	0x00	Unused list entry.
[7:0]	ConL0	R	0x02	DAC0 Converter widget

6.14.5. PortD PinWCntrl

Table 235. PortD PinWCntrl Command Verb Format

	Verb ID	Payload	Response
Get	F07	00	See bitfield table.
Set1	707	See bits [7:0] of bitfield table.	0000_0000h

Table 236. PortD PinWCntrl Command Response Format

Bit	Bitfield Name	RW	Reset	Description
[31:8]	Rsvd2	R	0x0	Reserved
[7]	HPhnEn	RW	0x0	1 = enable the low impedance amplifier associated with the output.
[6]	OutEn	RW	0x0	1 = (CODEC) output path of Pin Widget is enabled
[5]	InEn	RW	0x0	1 = (CODEC) input path of Pin Widget is enabled

Table 236. PortD PinWCntrl Command Response Format

Bit	Bitfield Name	RW	Reset	Description
[4:3]	Rsvd1	R	0x0	Reserved
[2:0]	VRefEn	RW	0x0	VRefEn: Selects one of the possible states for the VRef signal associated with the Pin Widget. If the value written to this control does not correspond to a supported value defined in the VRefCntrl field of the Pin Capabilities parameter (0C), then this control will take the value of 000b (Hi-Z).

6.14.6. PortD UnsolResp

Table 237. PortD UnsolResp Command Verb Format

	Verb ID	Payload	Response
Get	F08	00	See bitfield table.
Set1	708	See bits [7:0] of bitfield table.	0000_0000h

Table 238. PortD UnsolResp Command Response Format

Bit	Bitfield Name	RW	Reset	Description
[31:8]	Rsvd2	R	0x00	Reserved
[7]	En	RW	0x0	Allow generation of Unsolicited Responses. Unsolicited response events occur upon jack-insertion OR completion of a Jack-Sense cycle.
[6]	Rsvd1	R	0x0	Reserved
[5:0]	Tag	RW	0x00	Software programmable field returned in top six bits (31:26) of every Unsolicited Response generated by this node.

6.14.7. PortD ChSense

Table 239. PortD ChSense Command Verb Format

	Verb ID	Payload	Response
Get	F09	00	See bitfield table.
Set1	709	See bits [7:0] of bitfield table.	0000_0000h
Set2	709	See bits [7:0] of bitfield table.	0000_0000h

Table 240. PortD ChSense Command Response Format

Bit	Bitfield Name	RW	Reset	Description
[31]	PresDtct	R	0x0	1 = something is plugged into jack associated with Pin Complex.
[30:0]	Impedance	R	0x7FFF_FFFF	Measured impedance of the widget. A value of all 1s indicates that a valid sense reading is not available, or the sense measurement is busy if it has been recently triggered.
[0]	RightCh	W	0x0	Set 1 = perform impedance sensing on right channel or ring of the connector
[0]	LeftCh	W	0x0	Set 0 = perform impedance sensing on left channel or tip of the connector

6.14.8. PortD ConfigDefault

Table 241. PortD ConfigDefault Command Verb Format

	Verb ID	Payload	Response
Get	F1C	00	See bitfield table.
Set1	71C	See bits [7:0] of bitfield table.	0000_0000h
Set2	71D	See bits [7:0] of bitfield table.	0000_0000h
Set3	71E	See bits [7:0] of bitfield table.	0000_0000h
Set4	71F	See bits [7:0] of bitfield table.	0000_0000h

Table 242. PortD ConfigDefault Command Response Format

Bit	Bitfield Name	RW	Reset	Description
[31:24]	Config4	RW	0x01	Port Connectivity = Jack; Location = Mainboard rear.
[23:16]	Config3	RW	0x01	Default Device = Line Out; Connection Type = 1/8 inch jack.
[15:8]	Config2	RW	0x40	Color = Green; Misc = No jack detect override.
[7:0]	Config1	RW	0x10	Association = 1h; Sequence = 0h.

6.15. PortE Node (NID = 0x0E)

6.15.1. PortE WCap

Table 243. PortE WCap Command Verb Format

	Verb ID	Payload	Response
Get	F00	09	See bitfield table.

Table 244. PortE WCap Command Response Format

Bit	Bitfield Name	RW	Reset	Description
[31:24]	Rsvd2	R	0x0	Reserved
[23:20]	Type	R	0x4	Widget type = Pin Complex
[19:16]	Delay	R	0x0	Number of sample delays through widget
[15:12]	Rsvd1	R	0x0	Reserved
[11]	SwapCap	R	0x0	No left/right channel swap capability
[10]	PwrCntrl	R	0x0	No support for Power State control
[9]	Dig	R	0x0	Widget supports an Analog stream
[8]	ConnList	R	0x1	Connection list is present
[7]	UnSolCap	R	0x1	Unsolicited Response is supported
[6]	ProcWidget	R	0x0	No Processing Controls parameter
[5]	Stripe	R	0x0	No support for striping
[4]	FormatOvrd	R	0x0	N/A for pin complex
[3]	AmpParOvrd	R	0x0	No amplifier info; use default amplifier parameters from Audio Function node instead
[2]	OutAmpPrsnt	R	0x0	No output amp
[1]	InAmpPrsnt	R	0x0	No input amp
[0]	Stereo	R	0x1	Stereo widget

6.15.2. PortE PinCap

Table 245. PortE PinCap Command Verb Format

	Verb ID	Payload	Response
Get	F00	0C	See bitfield table.

Table 246. PortE PinCap Command Response Format

Bit	Bitfield Name	RW	Reset	Description
[31:17]	Rsvd2	R	0x0	Reserved
[16]	EapdCap	R	0x0	This widget does not control EAPD pin
[15:8]	VrefCntrl	R	0x17	VRef generation is supported by this pin complex, and the following voltages can be produced on the associated VRef pin: 80% Avdd; 50% Avdd; GND; Hi-Z (required since pin complex is output capable)
[7]	Rsvd1	R	0x0	Reserved
[6]	BalancedIO	R	0x0	Pin complex does not have balanced pins.
[5]	InCap	R	0x1	Pin complex is input capable.
[4]	OutCap	R	0x1	Pin complex is output capable.
[3]	HdphDrvCap	R	0x0	Pin does not have a headphone amplifier.
[2]	PresDtctCap	R	0x1	Pin complex can perform Presence Detect.
[1]	TrigRqd	R	0x1	Trigger is required for impedance measurement
[0]	ImpSenseCap	R	0x1	Pin complex supports impedance sense.

6.15.3. PortE ConLst

Table 247. PortE ConLst Command Verb Format

	Verb ID	Payload	Response
Get	F00	0E	See bitfield table.

Table 248. PortE ConLst Command Response Format

Bit	Bitfield Name	RW	Reset	Description
[31:8]	Rsvd	R	0x0	Reserved
[7]	LForm	R	0x0	Connection list uses short-form (7-bit) NID entries.
[6:0]	ConL	R	0x01	Number of NID entries in connection list.

6.15.4. PortE ConLstEntry

Table 249. PortE ConLstEntry Command Verb Format

	Verb ID	Payload	Response
Get	F02	00	See bitfield table.

Table 250. PortE ConLstEntry Command Response Format

Bit	Bitfield Name	RW	Reset	Description
[31:24]	ConL3	R	0x00	Unused list entry.
[23:16]	ConL2	R	0x00	Unused list entry.
[15:8]	ConL1	R	0x00	Unused list entry.
[7:0]	ConL0	R	0x04	DAC2 Converter widget

6.15.5. PortE PinWCntrl

Table 251. PortE PinWCntrl Command Verb Format

	Verb ID	Payload	Response
Get	F07	00	See bitfield table.
Set1	707	See bits [7:0] of bitfield table.	0000_0000h

Table 252. PortE PinWCntrl Command Response Format

Bit	Bitfield Name	RW	Reset	Description
[31:7]	Rsvd2	R	0x0	Reserved
[6]	OutEn	RW	0x0	1 = (CODEC) output path of Pin Widget is enabled

Table 252. PortE PinWCntrl Command Response Format

Bit	Bitfield Name	RW	Reset	Description
[5]	InEn	RW	0x0	1 = (CODEC) input path of Pin Widget is enabled
[4:3]	Rsvd1	R	0x0	Reserved
[2:0]	VRefEn	RW	0x0	VRefEn: Selects one of the possible states for the VRef signal associated with the Pin Widget. If the value written to this control does not correspond to a supported value defined in the VRefCntrl field of the Pin Capabilities parameter (0C), then this control will take the value of 000b (Hi-Z).

6.15.6. PortE UnsolResp

Table 253. PortE UnsolResp Command Verb Format

	Verb ID	Payload	Response
Get	F08	00	See bitfield table.
Set1	708	See bits [7:0] of bitfield table.	0000_0000h

Table 254. PortE UnsolResp Command Response Format

Bit	Bitfield Name	RW	Reset	Description
[31:8]	Rsvd2	R	0x00	Reserved
[7]	En	RW	0x0	Allow generation of Unsolicited Responses. Unsolicited response events occur upon jack-insertion OR completion of a Jack-Sense cycle.
[6]	Rsvd1	R	0x0	Reserved
[5:0]	Tag	RW	0x00	Software programmable field returned in top six bits (31:26) of every Unsolicited Response generated by this node.

6.15.7. PortE ChSense

Table 255. PortE ChSense Command Verb Format

	Verb ID	Payload	Response
Get	F09	00	See bitfield table.

Table 255. PortE ChSense Command Verb Format

	Verb ID	Payload	Response
Set1	709	See bits [7:0] of bitfield table.	0000_0000h
Set2	709	See bits [7:0] of bitfield table.	0000_0000h

Table 256. PortE ChSense Command Response Format

Bit	Bitfield Name	RW	Reset	Description
[31]	PresDtct	R	0x0	1 = something is plugged into jack associated with Pin Complex.
[30:0]	Impedance	R	0x7FFF_FFFF	Measured impedance of the widget. A value of all 1s indicates that a valid sense reading is not available, or the sense measurement is busy if it has been recently triggered.
[0]	RightCh	W	0x0	Set 1 = perform impedance sensing on right channel or ring of the connector
[0]	LeftCh	W	0x0	Set 0 = perform impedance sensing on left channel or tip of the connector

6.15.8. PortE ConfigDefault

Table 257. PortE ConfigDefault Command Verb Format

	Verb ID	Payload	Response
Get	F1C	00	See bitfield table.
Set1	71C	See bits [7:0] of bitfield table.	0000_0000h
Set2	71D	See bits [7:0] of bitfield table.	0000_0000h
Set3	71E	See bits [7:0] of bitfield table.	0000_0000h
Set4	71F	See bits [7:0] of bitfield table.	0000_0000h

Table 258. PortE ConfigDefault Command Response Format

Bit	Bitfield Name	RW	Reset	Description
[31:24]	Config4	RW	0x01	Port Connectivity = Jack; Location = Mainboard rear.
[23:16]	Config3	RW	0xA1	Default Device = Mic In; Connection Type = 1/8 inch jack.
[15:8]	Config2	RW	0x90	Color = Pink; Misc = No jack detect override.
[7:0]	Config1	RW	0x40	Association = 4h; Sequence = 0h.

6.16. PortF Node (NID = 0x0F)

6.16.1. PortF WCap

Table 259. PortF WCap Command Verb Format

	Verb ID	Payload	Response
Get	F00	09	See bitfield table.

Table 260. PortF WCap Command Response Format

Bit	Bitfield Name	RW	Reset	Description
[31:24]	Rsvd2	R	0x0	Reserved
[23:20]	Type	R	0x4	Widget type = Pin Complex
[19:16]	Delay	R	0x0	Number of sample delays through widget
[15:12]	Rsvd1	R	0x0	Reserved
[11]	SwapCap	R	0x0	No left/right channel swap capability
[10]	PwrCntrl	R	0x0	No support for Power State control
[9]	Dig	R	0x0	Widget supports an Analog stream
[8]	ConnList	R	0x1	Connection list is present
[7]	UnSolCap	R	0x1	Unsolicited Response is supported

Table 260. PortF WCap Command Response Format

Bit	Bitfield Name	RW	Reset	Description
[6]	ProcWidget	R	0x0	No Processing Controls parameter
[5]	Stripe	R	0x0	No support for striping
[4]	FormatOvrd	R	0x0	N/A for pin complex
[3]	AmpParOvrd	R	0x0	No amplifier info; use default amplifier parameters from Audio Function node instead
[2]	OutAmpPrsnt	R	0x0	No output amp
[1]	InAmpPrsnt	R	0x0	No input amp
[0]	Stereo	R	0x1	Stereo widget

6.16.2. PortF PinCap

Table 261. PortF PinCap Command Verb Format

	Verb ID	Payload	Response
Get	F00	0C	See bitfield table.

Table 262. PortF PinCap Command Response Format

Bit	Bitfield Name	RW	Reset	Description
[31:17]	Rsvd2	R	0x0	Reserved
[16]	EapdCap	R	0x0	This widget does not control EAPD pin
[15:8]	VrefCntrl	R	0x17	VRef generation is supported by this pin complex, and the following voltages can be produced on the associated VRef pin: 80% Avdd; 50% Avdd; GND; Hi-Z (required since pin complex is output capable)
[7]	Rsvd1	R	0x0	Reserved
[6]	BalancedIO	R	0x0	Pin complex does not have balanced pins.
[5]	InCap	R	0x1	Pin complex is input capable.
[4]	OutCap	R	0x1	Pin complex is output capable.

Table 262. PortF PinCap Command Response Format

Bit	Bitfield Name	RW	Reset	Description
[3]	HdphDrvCap	R	0x0	Pin does not have a headphone amplifier.
[2]	PresDtctCap	R	0x1	Pin complex can perform Presence Detect.
[1]	TrigRqd	R	0x1	Trigger is required for impedance measurement
[0]	ImpSenseCap	R	0x1	Pin complex supports impedance sense.

6.16.3. PortF ConLst

Table 263. PortF ConLst Command Verb Format

	Verb ID	Payload	Response
Get	F00	0E	See bitfield table.

Table 264. PortF ConLst Command Response Format

Bit	Bitfield Name	RW	Reset	Description
[31:8]	Rsvd	R	0x0	Reserved
[7]	LForm	R	0x0	Connection list uses short-form (7-bit) NID entries.
[6:0]	ConL	R	0x01	Number of NID entries in connection list.

6.16.4. PortF ConLstEntry

Table 265. PortF ConLstEntry Command Verb Format

	Verb ID	Payload	Response
Get	F02	00	See bitfield table.

Table 266. PortF ConLstEntry Command Response Format

Bit	Bitfield Name	RW	Reset	Description
[31:24]	ConL3	R	0x00	Unused list entry.
[23:16]	ConL2	R	0x00	Unused list entry.

Table 266. PortF ConLstEntry Command Response Format

Bit	Bitfield Name	RW	Reset	Description
[15:8]	ConL1	R	0x00	Unused list entry.
[7:0]	ConL0	R	0x05	DAC3 Converter widget

6.16.5. PortF PinWCntrl

Table 267. PortF PinWCntrl Command Verb Format

	Verb ID	Payload	Response
Get	F07	00	See bitfield table.
Set1	707	See bits [7:0] of bitfield table.	0000_0000h

Table 268. PortF PinWCntrl Command Response Format

Bit	Bitfield Name	RW	Reset	Description
[31:7]	Rsvd2	R	0x0	Reserved
[6]	OutEn	RW	0x0	1 = (CODEC) output path of Pin Widget is enabled
[5]	InEn	RW	0x0	1 = (CODEC) input path of Pin Widget is enabled
[4:3]	Rsvd1	R	0x0	Reserved
[2:0]	VRefEn	RW	0x0	VRefEn: Selects one of the possible states for the VRef signal associated with the Pin Widget. If the value written to this control does not correspond to a supported value defined in the VRefCntrl field of the Pin Capabilities parameter (0C), then this control will take the value of 000b (Hi-Z).

6.16.6. PortF UnsolResp

Table 269. PortF UnsolResp Command Verb Format

	Verb ID	Payload	Response
Get	F08	00	See bitfield table.
Set1	708	See bits [7:0] of bitfield table.	0000_0000h

Table 270. PortF UnsolResp Command Response Format

Bit	Bitfield Name	RW	Reset	Description
[31:8]	Rsvd2	R	0x00	Reserved
[7]	En	RW	0x0	Allow generation of Unsolicited Responses. Unsolicited response events occur upon jack-insertion OR completion of a Jack-Sense cycle.
[6]	Rsvd1	R	0x0	Reserved
[5:0]	Tag	RW	0x00	Software programmable field returned in top six bits (31:26) of every Unsolicited Response generated by this node.

6.16.7. PortF ChSense

Table 271. PortF ChSense Command Verb Format

	Verb ID	Payload	Response
Get	F09	00	See bitfield table.
Set1	709	See bits [7:0] of bitfield table.	0000_0000h
Set2	709	See bits [7:0] of bitfield table.	0000_0000h

Table 272. PortF ChSense Command Response Format

Bit	Bitfield Name	RW	Reset	Description
[31]	PresDtct	R	0x0	1 = something is plugged into jack associated with Pin Complex.
[30:0]	Impedance	R	0x7FFF_FFFF	Measured impedance of the widget. A value of all 1s indicates that a valid sense reading is not available, or the sense measurement is busy if it has been recently triggered.
[0]	RightCh	W	0x0	Set 1 = perform impedance sensing on right channel or ring of the connector
[0]	LeftCh	W	0x0	Set 0 = perform impedance sensing on left channel or tip of the connector

6.16.8. PortF ConfigDefault

Table 273. PortF ConfigDefault Command Verb Format

	Verb ID	Payload	Response
Get	F1C	00	See bitfield table.
Set1	71C	See bits [7:0] of bitfield table.	0000_0000h
Set2	71D	See bits [7:0] of bitfield table.	0000_0000h
Set3	71E	See bits [7:0] of bitfield table.	0000_0000h
Set4	71F	See bits [7:0] of bitfield table.	0000_0000h

Table 274. PortF ConfigDefault Command Response Format

Bit	Bitfield Name	RW	Reset	Description
[31:24]	Config4	RW	0x01	Port Connectivity = Jack; Location = Mainboard rear.
[23:16]	Config3	RW	0x01	Default Device = Line Out; Connection Type = 1/8 inch jack.
[15:8]	Config2	RW	0x10	Color = Black; Misc = No jack detect override.
[7:0]	Config1	RW	0x12	Association = 1h; Sequence = 2h.

6.17. PortG Node (NID = 0x10)

6.17.1. PortG WCap

Table 275. PortG WCap Command Verb Format

	Verb ID	Payload	Response
Get	F00	09	See bitfield table.

Table 276. PortG WCap Command Response Format

Bit	Bitfield Name	RW	Reset	Description
[31:24]	Rsvd2	R	0x0	Reserved
[23:20]	Type	R	0x4	Widget type = Pin Complex

Table 276. PortG WCap Command Response Format

Bit	Bitfield Name	RW	Reset	Description
[19:16]	Delay	R	0x0	Number of sample delays through widget
[15:12]	Rsvd1	R	0x0	Reserved
[11]	SwapCap	R	0x0	No left/right channel swap capability
[10]	PwrCntrl	R	0x0	No support for Power State control
[9]	Dig	R	0x0	Widget supports an Analog stream
[8]	ConnList	R	0x1	Connection list is present
[7]	UnSolCap	R	0x1	Unsolicited Response is supported
[6]	ProcWidget	R	0x0	No Processing Controls parameter
[5]	Stripe	R	0x0	No support for striping
[4]	FormatOvrd	R	0x0	N/A for pin complex
[3]	AmpParOvrd	R	0x0	No amplifier info; use default amplifier parameters from Audio Function node instead
[2]	OutAmpPrsnt	R	0x0	No output amp
[1]	InAmpPrsnt	R	0x0	No input amp
[0]	Stereo	R	0x1	Stereo widget

6.17.2. PortG PinCap

Table 277. PortG PinCap Command Verb Format

	Verb ID	Payload	Response
Get	F00	0C	See bitfield table.

Table 278. PortG PinCap Command Response Format

Bit	Bitfield Name	RW	Reset	Description
[31:17]	Rsvd2	R	0x0	Reserved
[16]	EapdCap	R	0x0	This widget does not control EAPD pin

Table 278. PortG PinCap Command Response Format

Bit	Bitfield Name	RW	Reset	Description
[15:8]	VrefCntrl	R	0x00	VRef generation not supported by this pin complex.
[7]	Rsvd1	R	0x0	Reserved
[6]	BalancedIO	R	0x0	Pin complex does not have balanced pins.
[5]	InCap	R	0x1	Pin complex is input capable.
[4]	OutCap	R	0x1	Pin complex is output capable.
[3]	HdphDrvCap	R	0x0	Pin does not have a headphone amplifier.
[2]	PresDtctCap	R	0x1	Pin complex can perform Presence Detect.
[1]	TrigRqd	R	0x1	Trigger is required for impedance measurement
[0]	ImpSenseCap	R	0x1	Pin complex supports impedance sense.

6.17.3. PortG ConLst

Table 279. PortG ConLst Command Verb Format

	Verb ID	Payload	Response
Get	F00	0E	See bitfield table.

Table 280. PortG ConLst Command Response Format

Bit	Bitfield Name	RW	Reset	Description
[31:8]	Rsvd	R	0x0	Reserved
[7]	LForm	R	0x0	Connection list uses short-form (7-bit) NID entries.
[6:0]	ConL	R	0x01	Number of NID entries in connection list.

6.17.4. PortG ConLstEntry

Table 281. PortG ConLstEntry Command Verb Format

	Verb ID	Payload	Response
Get	F02	00	See bitfield table.

Table 282. PortG ConLstEntry Command Response Format

Bit	Bitfield Name	RW	Reset	Description
[31:24]	ConL3	R	0x00	Unused list entry.
[23:16]	ConL2	R	0x00	Unused list entry.
[15:8]	ConL1	R	0x00	Unused list entry.
[7:0]	ConL0	R	0x04	DAC2 Converter widget

6.17.5. PortG PinWCntrl

Table 283. PortG PinWCntrl Command Verb Format

	Verb ID	Payload	Response
Get	F07	00	See bitfield table.
Set1	707	See bits [7:0] of bitfield table.	0000_0000h

Table 284. PortG PinWCntrl Command Response Format

Bit	Bitfield Name	RW	Reset	Description
[31:7]	Rsvd2	R	0x0	Reserved
[6]	OutEn	RW	0x0	1 = (CODEC) output path of Pin Widget is enabled
[5]	InEn	RW	0x0	1 = (CODEC) input path of Pin Widget is enabled
[4:3]	Rsvd1	R	0x0	Reserved
[2:0]	VRefEn	R	0x0	Vref Out not supported on this Port

6.17.6. PortG UnsolResp

Table 285. PortG UnsolResp Command Verb Format

	Verb ID	Payload	Response
Get	F08	00	See bitfield table.
Set1	708	See bits [7:0] of bitfield table.	0000_0000h

Table 286. PortG UnsolResp Command Response Format

Bit	Bitfield Name	RW	Reset	Description
[31:8]	Rsvd2	R	0x00	Reserved
[7]	En	RW	0x0	Allow generation of Unsolicited Responses. Unsolicited response events occur upon jack-insertion OR completion of a Jack-Sense cycle.
[6]	Rsvd1	R	0x0	Reserved
[5:0]	Tag	RW	0x00	Software programmable field returned in top six bits (31:26) of every Unsolicited Response generated by this node.

6.17.7. PortG ChSense

Table 287. PortG ChSense Command Verb Format

	Verb ID	Payload	Response
Get	F09	00	See bitfield table.
Set1	709	See bits [7:0] of bitfield table.	0000_0000h
Set2	709	See bits [7:0] of bitfield table.	0000_0000h

Table 288. PortG ChSense Command Response Format

Bit	Bitfield Name	RW	Reset	Description
[31]	PresDtct	R	0x0	1 = something is plugged into jack associated with Pin Complex.
[30:0]	Impedance	R	0x7FFF_FFFF	Measured impedance of the widget. A value of all 1s indicates that a valid sense reading is not available, or the sense measurement is busy if it has been recently triggered.
[0]	RightCh	W	0x0	Set 1 = perform impedance sensing on right channel or ring of the connector
[0]	LeftCh	W	0x0	Set 0 = perform impedance sensing on left channel or tip of the connector

6.17.8. PortG ConfigDefault

Table 289. PortG ConfigDefault Command Verb Format

	Verb ID	Payload	Response
Get	F1C	00	See bitfield table.
Set1	71C	See bits [7:0] of bitfield table.	0000_0000h
Set2	71D	See bits [7:0] of bitfield table.	0000_0000h
Set3	71E	See bits [7:0] of bitfield table.	0000_0000h
Set4	71F	See bits [7:0] of bitfield table.	0000_0000h

Table 290. PortG ConfigDefault Command Response Format

Bit	Bitfield Name	RW	Reset	Description
[31:24]	Config4	RW	0x01	Port Connectivity = Jack; Location = Mainboard rear.
[23:16]	Config3	RW	0x01	Default Device = Line Out; Connection Type = 1/8 inch jack.
[15:8]	Config2	RW	0x60	Color = Orange; Misc = No jack detect override.
[7:0]	Config1	RW	0x11	Association = 1h; Sequence = 1h.

6.18. PortH Node (NID = 0x11)

6.18.1. PortH WCap

Table 291. PortH WCap Command Verb Format

	Verb ID	Payload	Response
Get	F00	09	See bitfield table.

Table 292. PortH WCap Command Response Format

Bit	Bitfield Name	RW	Reset	Description
[31:24]	Rsvd2	R	0x0	Reserved
[23:20]	Type	R	0x4	Widget type = Pin Complex

Table 292. Porth WCap Command Response Format

Bit	Bitfield Name	RW	Reset	Description
[19:16]	Delay	R	0x0	Number of sample delays through widget
[15:12]	Rsvd1	R	0x0	Reserved
[11]	SwapCap	R	0x0	No left/right channel swap capability
[10]	PwrCntrl	R	0x0	No support for Power State control
[9]	Dig	R	0x0	Widget supports an Analog stream
[8]	ConnList	R	0x1	Connection list is present
[7]	UnSolCap	R	0x1	Unsolicited Response is supported
[6]	ProcWidget	R	0x0	No Processing Controls parameter
[5]	Stripe	R	0x0	No support for striping
[4]	FormatOvrd	R	0x0	N/A for pin complex
[3]	AmpParOvrd	R	0x0	No amplifier info; use default amplifier parameters from Audio Function node instead
[2]	OutAmpPrsnt	R	0x0	No output amp
[1]	InAmpPrsnt	R	0x0	No input amp
[0]	Stereo	R	0x1	Stereo widget

6.18.2. Porth PinCap

Table 293. Porth PinCap Command Verb Format

	Verb ID	Payload	Response
Get	F00	0C	See bitfield table.

Table 294. Porth PinCap Command Response Format

Bit	Bitfield Name	RW	Reset	Description
[31:17]	Rsvd2	R	0x0	Reserved
[16]	EapdCap	R	0x0	This widget does not control EAPD pin

Table 294. Porth PinCap Command Response Format

Bit	Bitfield Name	RW	Reset	Description
[15:8]	VrefCntrl	R	0x00	VRef generation not supported by this pin complex.
[7]	Rsvd1	R	0x0	Reserved
[6]	BalancedIO	R	0x0	Pin complex does not have balanced pins.
[5]	InCap	R	0x1	Pin complex is input capable.
[4]	OutCap	R	0x1	Pin complex is output capable.
[3]	HdphDrvCap	R	0x0	Pin does not have a headphone amplifier.
[2]	PresDtctCap	R	0x1	Pin complex can perform Presence Detect.
[1]	TrigRqd	R	0x1	Trigger is required for impedance measurement
[0]	ImpSenseCap	R	0x1	Pin complex supports impedance sense.

6.18.3. Porth ConLst

Table 295. Porth ConLst Command Verb Format

	Verb ID	Payload	Response
Get	F00	0E	See bitfield table.

Table 296. Porth ConLst Command Response Format

Bit	Bitfield Name	RW	Reset	Description
[31:8]	Rsvd	R	0x0	Reserved
[7]	LForm	R	0x0	Connection list uses short-form (7-bit) NID entries.
[6:0]	ConL	R	0x01	Number of NID entries in connection list.

6.18.4. Porth ConLstEntry

Table 297. Porth ConLstEntry Command Verb Format

	Verb ID	Payload	Response
Get	F02	00	See bitfield table.

Table 298. Porth ConLstEntry Command Response Format

Bit	Bitfield Name	RW	Reset	Description
[31:24]	ConL3	R	0x00	Unused list entry.
[23:16]	ConL2	R	0x00	Unused list entry.
[15:8]	ConL1	R	0x00	Unused list entry.
[7:0]	ConL0	R	0x03	DAC1 Converter widget

6.18.5. Porth PinWCntrl

Table 299. Porth PinWCntrl Command Verb Format

	Verb ID	Payload	Response
Get	F07	00	See bitfield table.
Set1	707	See bits [7:0] of bitfield table.	0000_0000h

Table 300. Porth PinWCntrl Command Response Format

Bit	Bitfield Name	RW	Reset	Description
[31:7]	Rsvd2	R	0x0	Reserved
[6]	OutEn	RW	0x0	1 = (CODEC) output path of Pin Widget is enabled
[5]	InEn	RW	0x0	1 = (CODEC) input path of Pin Widget is enabled
[4:3]	Rsvd1	R	0x0	Reserved
[2:0]	VRefEn	R	0x0	Vref Out not supported on this Port

6.18.6. Porth UnsolResp

Table 301. Porth UnsolResp Command Verb Format

	Verb ID	Payload	Response
Get	F08	00	See bitfield table.
Set1	708	See bits [7:0] of bitfield table.	0000_0000h

Table 302. Porth UnsolResp Command Response Format

Bit	Bitfield Name	RW	Reset	Description
[31:8]	Rsvd2	R	0x00	Reserved
[7]	En	RW	0x0	Allow generation of Unsolicited Responses. Unsolicited response events occur upon jack-insertion OR completion of a Jack-Sense cycle.
[6]	Rsvd1	R	0x0	Reserved
[5:0]	Tag	RW	0x00	Software programmable field returned in top six bits (31:26) of every Unsolicited Response generated by this node.

6.18.7. Porth ChSense

Table 303. Porth ChSense Command Verb Format

	Verb ID	Payload	Response
Get	F09	00	See bitfield table.
Set1	709	See bits [7:0] of bitfield table.	0000_0000h
Set2	709	See bits [7:0] of bitfield table.	0000_0000h

Table 304. Porth ChSense Command Response Format

Bit	Bitfield Name	RW	Reset	Description
[31]	PresDtct	R	0x0	1 = something is plugged into jack associated with Pin Complex.
[30:0]	Impedance	R	0x7FFF_FFFF	Measured impedance of the widget. A value of all 1s indicates that a valid sense reading is not available, or the sense measurement is busy if it has been recently triggered.
[0]	RightCh	W	0x0	Set 1 = perform impedance sensing on right channel or ring of the connector
[0]	LeftCh	W	0x0	Set 0 = perform impedance sensing on left channel or tip of the connector

6.18.8. Porth ConfigDefault

Table 305. Porth ConfigDefault Command Verb Format

	Verb ID	Payload	Response
Get	F1C	00	See bitfield table.
Set1	71C	See bits [7:0] of bitfield table.	0000_0000h
Set2	71D	See bits [7:0] of bitfield table.	0000_0000h
Set3	71E	See bits [7:0] of bitfield table.	0000_0000h
Set4	71F	See bits [7:0] of bitfield table.	0000_0000h

Table 306. Porth ConfigDefault Command Response Format

Bit	Bitfield Name	RW	Reset	Description
[31:24]	Config4	RW	0x01	Port Connectivity = Jack; Location = Mainboard rear.
[23:16]	Config3	RW	0x01	Default Device = Line Out; Connection Type = 1/8 inch jack.
[15:8]	Config2	RW	0x20	Color = Grey; Misc = No jack detect override.
[7:0]	Config1	RW	0x14	Association = 1h; Sequence = 4h.

6.19. DigOut0 Node (NID = 0x21)

6.19.1. DigOut0 WCap

Table 307. DigOut0 WCap Command Verb Format

	Verb ID	Payload	Response
Get	F00	09	See bitfield table.

Table 308. DigOut0 WCap Command Response Format

Bit	Bitfield Name	RW	Reset	Description
[31:24]	Rsvd2	R	0x0	Reserved
[23:20]	Type	R	0x4	Widget type = Pin Complex

Table 308. DigOut0 WCap Command Response Format

Bit	Bitfield Name	RW	Reset	Description
[19:16]	Delay	R	0x0	Number of sample delays through widget
[15:12]	Rsvd1	R	0x0	Reserved
[11]	SwapCap	R	0x0	No support for swapping left and right channels
[10]	PwrCntrl	R	0x0	No support for Power State control
[9]	Dig	R	0x1	Widget supports a Digital stream
[8]	ConnList	R	0x1	Connection list is present
[7]	UnSolCap	R	0x0	No support for Unsolicited Response
[6]	ProcWidget	R	0x0	No Processing Controls parameter
[5]	Stripe	R	0x0	No support for striping
[4]	FormatOvrd	R	0x0	N/A for pin complex
[3]	AmpParOvrd	R	0x0	No amplifier info; use default amplifier parameters from Audio Function node instead
[2]	OutAmpPrsnt	R	0x0	No output amp
[1]	InAmpPrsnt	R	0x0	No input amp
[0]	Stereo	R	0x1	Stereo widget

6.19.2. DigOut0 PinCap

Table 309. DigOut0 PinCap Command Verb Format

	Verb ID	Payload	Response
Get	F00	0C	See bitfield table.

Table 310. DigOut0 PinCap Command Response Format

Bit	Bitfield Name	RW	Reset	Description
[31:17]	Rsvd2	R	0x0	Reserved
[16]	EapdCap	R	0x0	This widget does not control EAPD pin
[15:8]	VrefCntrl	R	0x00	Vref generation not supported on this pin

Table 310. DigOut0 PinCap Command Response Format

Bit	Bitfield Name	RW	Reset	Description
[7]	Rsvd1	R	0x0	Reserved
[6]	BalancedIO	R	0x0	Pin complex does not have balanced pins.
[5]	InCap	R	0x0	Pin complex is not input capable.
[4]	OutCap	R	0x1	Pin complex is output capable.
[3]	HdphDrvCap	R	0x0	Pin does not have a headphone amplifier.
[2]	PresDtctCap	R	0x0	Pin complex cannot perform Presence Detect.
[1]	TrigRqd	R	0x0	N/A
[0]	ImpSenseCap	R	0x0	Pin complex does not support impedance sense.

6.19.3. DigOut0 ConLst

Table 311. DigOut0 ConLst Command Verb Format

	Verb ID	Payload	Response
Get	F00	0E	See bitfield table.

Table 312. DigOut0 ConLst Command Response Format

Bit	Bitfield Name	RW	Reset	Description
[31:8]	Rsvd	R	0x0	Reserved.
[7]	LForm	R	0x0	Connection list uses short-form (7-bit) NID entries.
[6:0]	ConL	R	0x05	Number of NID entries in connection list.

6.19.4. DigOut0 ConLstEntry0

Table 313. DigOut0 ConLstEntry0 Command Verb Format

	Verb ID	Payload	Response
Get	F02	00	See bitfield table.

Table 314. DigOut0 ConLstEntry0 Command Response Format

Bit	Bitfield Name	RW	Reset	Description
[31:24]	ConL3	R	0x1C	ADC1Mux widget
[23:16]	ConL2	R	0x1B	ADC0Mux widget
[15:8]	Rsvd	R	0x1F	Reserved
[7:0]	ConL0	R	0x1E	SPDIF Out Converter widget

6.19.5. DigOut0 ConLstEntry4

Table 315. DigOut0 ConLstEntry4 Command Verb Format

	Verb ID	Payload	Response
Get	F02	04	See bitfield table.

Table 316. DigOut0 ConLstEntry4 Command Response Format

Bit	Bitfield Name	RW	Reset	Description
[31:24]	ConL7	R	0x00	No connection
[23:16]	ConL6	R	0x00	No connection
[15:8]	ConL5	R	0x00	No connection
[7:0]	ConL4	R	0x1D	ADC2Mux widget

6.19.6. DigOut0 ConSelectCtrl

Table 317. DigOut0 ConSelectCtrl Command Verb Format

	Verb ID	Payload	Response
Get	F01	00	See bitfield table.
Set1	701	See bits [7:0] of bitfield table.	0000_0000h

Table 318. DigOut0 ConSelectCtrl Command Response Format

Bit	Bitfield Name	RW	Reset	Description
[31:1]	Rsvd	R	0x0	Reserved
[2:0]	Index	RW	0x0	Connection select control index.

6.19.7. DigOut0 PinWCntrl

Table 319. DigOut0 PinWCntrl Command Verb Format

	Verb ID	Payload	Response
Get	F07	00	See bitfield table.
Set1	707	See bits [7:0] of bitfield table.	0000_0000h

Table 320. DigOut0 PinWCntrl Command Response Format

Bit	Bitfield Name	RW	Reset	Description
[31:7]	Rsvd2	R	0x0	Reserved
[6]	OutEn	RW	0x0	1 = (CODEC) output path of Pin Widget is enabled
[5:0]	Rsvd1	R	0x0	Reserved

6.19.8. DigOut0 ConfigDefault

Table 321. DigOut0 ConfigDefault Command Verb Format

	Verb ID	Payload	Response
Get	F1C	00	See bitfield table.
Set1	71C	See bits [7:0] of bitfield table.	0000_0000h
Set2	71D	See bits [7:0] of bitfield table.	0000_0000h
Set3	71E	See bits [7:0] of bitfield table.	0000_0000h
Set4	71F	See bits [7:0] of bitfield table.	0000_0000h

Table 322. DigOut0 ConfigDefault Command Response Format

Bit	Bitfield Name	RW	Reset	Description
[31:24]	Config4	RW	0x01	Port Connectivity = Jack; Location = Mainboard rear.
[23:16]	Config3	RW	0x44	Default Device = SPDIF Out; Connection Type = RCA.
[15:8]	Config2	RW	0x21	Color = Grey; Misc = Jack detect override.
[7:0]	Config1	RW	0x70	Association = 7h; Sequence = 0h.

6.20. InPort0Mux Node (NID = 0x15)

6.20.1. InPort0Mux WCap

Table 323. InPort0Mux WCap Command Verb Format

	Verb ID	Payload	Response
Get	F00	09	See bitfield table.

Table 324. InPort0Mux WCap Command Response Format

Bit	Bitfield Name	RW	Reset	Description
[31:24]	Rsvd2	R	0x0	Reserved
[23:20]	Type	R	0x3	Widget type = Audio Selector
[19:16]	Delay	R	0x0	Number of sample delays through widget
[15:12]	Rsvd1	R	0x0	Reserved
[11]	SwapCap	R	0x0	No left/right channel swap capability
[10]	PwrCntrl	R	0x0	No support for Power State control
[9]	Dig	R	0x0	Widget supports an Analog stream
[8]	ConnList	R	0x1	Connection list is present
[7]	UnSolCap	R	0x0	No support for Unsolicited Response

Table 324. InPort0Mux WCap Command Response Format

Bit	Bitfield Name	RW	Reset	Description
[6]	ProcWidget	R	0x0	No Processing Controls parameter.
[5]	Stripe	R	0x0	No support for striping
[4]	FormatOvrd	R	0x0	No format info; use default format parameters from Audio Function node instead
[3]	AmpParOvrd	R	0x1	This widget contains its own amplifier parameters.
[2]	OutAmpPrsnt	R	0x1	Output amp is present
[1]	InAmpPrsnt	R	0x0	No input amp
[0]	Stereo	R	0x1	Stereo widget

6.20.2. InPort0Mux ConLst

Table 325. InPort0Mux ConLst Command Verb Format

	Verb ID	Payload	Response
Get	F00	0E	See bitfield table.

Table 326. InPort0Mux ConLst Command Response Format

Bit	Bitfield Name	RW	Reset	Description
[31:8]	Rsvd	R	0x0	Reserved
[7]	LForm	R	0x0	Connection list uses short-form (7-bit) NID entries.
[6:0]	ConL	R	0x09	Number of NID entries in connection list.

6.20.3. InPort0Mux OutAmpCap

Table 327. InPort0Mux OutAmpCap Command Verb Format

	Verb ID	Payload	Response
Get	F00	12	See bitfield table.

Table 328. InPort0Mux OutAmpCap Command Response Format

Bit	Bitfield Name	RW	Reset	Description
[31]	Mute	R	0x0	No mute capability
[30:23]	Rsvd3	R	0x0	Reserved
[22:16]	StepSize	R	0x27	Size of each step in the gain range = 10dB
[15]	Rsvd2	R	0x0	Reserved
[14:8]	NumSteps	R	0x04	Number of steps in the gain range = 5 (0dB to +40dB)
[7]	Rsvd1	R	0x0	Reserved
[6:0]	Offset	R	0x00	0dB-step is programmed with this offset

6.20.4. InPort0Mux OutAmpRight

Table 329. InPort0Mux OutAmpRight Command Verb Format

	Verb ID	Payload	Response
Get	B80	00	See bitfield table.
Set1	390	See bits [7:0] of bitfield table.	0000_0000h

Table 330. InPort0Mux OutAmpRight Command Response Format

Bit	Bitfield Name	RW	Reset	Description
[31:3]	Rsvd1	R	0x0	Reserved
[2:0]	Gain	RW	0x0	Amplifier gain step number: 000 = 0dB; 001 = 10dB; 010 = 20dB; 011 = 30dB; 100 = 40dB

6.20.5. InPort0Mux OutAmpLeft

Table 331. InPort0Mux OutAmpLeft Command Verb Format

	Verb ID	Payload	Response
Get	BA0	00	See bitfield table.
Set1	3A0	See bits [7:0] of bitfield table.	0000_0000h

Table 332. InPort0Mux OutAmpLeft Command Response Format

Bit	Bitfield Name	RW	Reset	Description
[31:3]	Rsvd1	R	0x0	Reserved
[2:0]	Gain	RW	0x0	Amplifier gain step number: 000 = 0dB; 001 = 10dB; 010 = 20dB; 011 = 30dB; 100 = 40dB

6.20.6. InPort0Mux ConSelectCtrl

Table 333. InPort0Mux ConSelectCtrl Command Verb Format

	Verb ID	Payload	Response
Get	F01	00	See bitfield table.
Set1	701	See bits [7:0] of bitfield table.	0000_0000h

Table 334. InPort0Mux ConSelectCtrl Command Response Format

Bit	Bitfield Name	RW	Reset	Description
[31:4]	Rsvd	R	0x0	Reserved
[3:0]	Index	RW	0x0	Connection select control index. (Default = Port E)

6.20.7. InPort0Mux ConLstEntry0

Table 335. InPort0Mux ConLstEntry0 Command Verb Format

	Verb ID	Payload	Response
Get	F02	00	See bitfield table.

Table 336. InPort0Mux ConLstEntry0 Command Response Format

Bit	Bitfield Name	RW	Reset	Description
[31:24]	ConL3	R	0x0B	Port B
[23:16]	ConL2	R	0x0F	Port F
[15:8]	ConL1	R	0x12	CD In
[7:0]	ConL0	R	0x0E	Port E (default)

6.20.8. InPort0Mux ConLstEntry4

Table 337. InPort0Mux ConLstEntry4 Command Verb Format

	Verb ID	Payload	Response
Get	F02	04	See bitfield table.

Table 338. InPort0Mux ConLstEntry4 Command Response Format

Bit	Bitfield Name	RW	Reset	Description
[31:24]	ConL7	R	0x10	Port G
[23:16]	ConL6	R	0x0A	Port A
[15:8]	ConL5	R	0x0D	Port D
[7:0]	ConL4	R	0x0C	Port C

6.20.9. InPort0Mux ConLstEntry8

Table 339. InPort0Mux ConLstEntry8 Command Verb Format

	Verb ID	Payload	Response
Get	F02	08	See bitfield table.

Table 340. InPort0Mux ConLstEntry8 Command Response Format

Bit	Bitfield Name	RW	Reset	Description
[31:24]	ConL11	R	0x0	No connection.
[23:16]	ConL10	R	0x0	No connection.

Table 340. InPort0Mux ConLstEntry8 Command Response Format

Bit	Bitfield Name	RW	Reset	Description
[15:8]	ConL9	R	0x0	No connection.
[7:0]	ConL8	R	0x11	Port H

6.21. InPort1Mux Node (NID = 0x16)

6.21.1. InPort1Mux WCap

Table 341. InPort1Mux WCap Command Verb Format

	Verb ID	Payload	Response
Get	F00	09	See bitfield table.

Table 342. InPort1Mux WCap Command Response Format

Bit	Bitfield Name	RW	Reset	Description
[31:24]	Rsvd2	R	0x0	Reserved
[23:20]	Type	R	0x3	Widget type = Audio Selector
[19:16]	Delay	R	0x0	Number of sample delays through widget
[15:12]	Rsvd1	R	0x0	Reserved
[11]	SwapCap	R	0x0	No left/right channel swap capability
[10]	PwrCntrl	R	0x0	No support for Power State control
[9]	Dig	R	0x0	Widget supports an Analog stream
[8]	ConnList	R	0x1	Connection list is present
[7]	UnSolCap	R	0x0	No support for Unsolicited Response
[6]	ProcWidget	R	0x0	No Processing Controls parameter.
[5]	Stripe	R	0x0	No support for striping
[4]	FormatOvrd	R	0x0	No format info; use default format parameters from Audio Function node instead

Table 342. InPort1Mux WCap Command Response Format

Bit	Bitfield Name	RW	Reset	Description
[3]	AmpParOvrd	R	0x1	This widget contains its own amplifier parameters.
[2]	OutAmpPrsnt	R	0x1	Output amp is present
[1]	InAmpPrsnt	R	0x0	No input amp
[0]	Stereo	R	0x1	Stereo widget

6.21.2. InPort1Mux ConLst

Table 343. InPort1Mux ConLst Command Verb Format

	Verb ID	Payload	Response
Get	F00	0E	See bitfield table.

Table 344. InPort1Mux ConLst Command Response Format

Bit	Bitfield Name	RW	Reset	Description
[31:8]	Rsvd	R	0x0	Reserved
[7]	LForm	R	0x0	Connection list uses short-form (7-bit) NID entries.
[6:0]	ConL	R	0x09	Number of NID entries in connection list.

6.21.3. InPort1Mux OutAmpCap

Table 345. InPort1Mux OutAmpCap Command Verb Format

	Verb ID	Payload	Response
Get	F00	12	See bitfield table.

Table 346. InPort1Mux OutAmpCap Command Response Format

Bit	Bitfield Name	RW	Reset	Description
[31]	Mute	R	0x0	No mute capability
[30:23]	Rsvd3	R	0x0	Reserved
[22:16]	StepSize	R	0x27	Size of each step in the gain range = 10dB

Table 346. InPort1Mux OutAmpCap Command Response Format

Bit	Bitfield Name	RW	Reset	Description
[15]	Rsvd2	R	0x0	Reserved
[14:8]	NumSteps	R	0x04	Number of steps in the gain range = 5 (0dB to +40dB)
[7]	Rsvd1	R	0x0	Reserved
[6:0]	Offset	R	0x00	0dB-step is programmed with this offset

6.21.4. InPort1Mux OutAmpRight

Table 347. InPort1Mux OutAmpRight Command Verb Format

	Verb ID	Payload	Response
Get	B80	00	See bitfield table.
Set1	390	See bits [7:0] of bitfield table.	0000_0000h

Table 348. InPort1Mux OutAmpRight Command Response Format

Bit	Bitfield Name	RW	Reset	Description
[31:3]	Rsvd1	R	0x0	Reserved
[2:0]	Gain	RW	0x0	Amplifier gain step number: 000 = 0dB; 001 = 10dB; 010 = 20dB; 011 = 30dB; 100 = 40dB

6.21.5. InPort1Mux OutAmpLeft

Table 349. InPort1Mux OutAmpLeft Command Verb Format

	Verb ID	Payload	Response
Get	BA0	00	See bitfield table.
Set1	3A0	See bits [7:0] of bitfield table.	0000_0000h

Table 350. InPort1Mux OutAmpLeft Command Response Format

Bit	Bitfield Name	RW	Reset	Description
[31:3]	Rsvd1	R	0x0	Reserved
[2:0]	Gain	RW	0x0	Amplifier gain step number: 000 = 0dB; 001 = 10dB; 010 = 20dB; 011 = 30dB; 100 = 40dB

6.21.6. InPort1Mux ConSelectCtrl

Table 351. InPort1Mux ConSelectCtrl Command Verb Format

	Verb ID	Payload	Response
Get	F01	00	See bitfield table.
Set1	701	See bits [7:0] of bitfield table.	0000_0000h

Table 352. InPort1Mux ConSelectCtrl Command Response Format

Bit	Bitfield Name	RW	Reset	Description
[31:4]	Rsvd	R	0x0	Reserved
[3:0]	Index	RW	0x0	Connection select control index. (Default = Port E)

6.21.7. InPort1Mux ConLstEntry0

Table 353. InPort1Mux ConLstEntry0 Command Verb Format

	Verb ID	Payload	Response
Get	F02	00	See bitfield table.

Table 354. InPort1Mux ConLstEntry0 Command Response Format

Bit	Bitfield Name	RW	Reset	Description
[31:24]	ConL3	R	0x0B	Port B
[23:16]	ConL2	R	0x0F	Port F

Table 354. InPort1Mux ConLstEntry0 Command Response Format

Bit	Bitfield Name	RW	Reset	Description
[15:8]	ConL1	R	0x12	CD In
[7:0]	ConL0	R	0x0E	Port E (default)

6.21.8. InPort1Mux ConLstEntry4

Table 355. InPort1Mux ConLstEntry4 Command Verb Format

	Verb ID	Payload	Response
Get	F02	04	See bitfield table.

Table 356. InPort1Mux ConLstEntry4 Command Response Format

Bit	Bitfield Name	RW	Reset	Description
[31:24]	ConL7	R	0x10	Port G
[23:16]	ConL6	R	0x0A	Port A
[15:8]	ConL5	R	0x0D	Port D
[7:0]	ConL4	R	0x0C	Port C

6.21.9. InPort1Mux ConLstEntry8

Table 357. InPort1Mux ConLstEntry8 Command Verb Format

	Verb ID	Payload	Response
Get	F02	08	See bitfield table.

Table 358. InPort1Mux ConLstEntry8 Command Response Format

Bit	Bitfield Name	RW	Reset	Description
[31:24]	ConL11	R	0x0	No connection.
[23:16]	ConL10	R	0x0	No connection.
[15:8]	ConL9	R	0x0	No connection.
[7:0]	ConL8	R	0x11	Port H

6.22. PCBEEP Node (NID = 0x23)

6.22.1. PCBEEP OutAmpLeft

Table 359. PCBEEP OutAmpLeft Command Verb Format

	Verb ID	Payload	Response
Get	BA0	00	See bitfield table.
Set1	3A0	See bits [7:0] of bitfield table.	0000_0000h

Table 360. PCBEEP OutAmpLeft Command Response Format

Bit	Bitfield Name	RW	Reset	Description
[31:8]	Rsvd2	R	0x0	Reserved
[7]	Mute	RW	0x0	1 = disable Digital PC Beep
[6:2]	Rsvd1	R	0x0	Reserved
[1:0]	Gain	RW	0x0	Mono (left) amplifier gain step number

6.22.2. PCBEEP WCap

Table 361. PCBEEP WCap Command Verb Format

	Verb ID	Payload	Response
Get	F00	09	See bitfield table.

Table 362. PCBEEP WCap Command Response Format

Bit	Bitfield Name	RW	Reset	Description
[31:24]	Rsvd2	R	0x0	Reserved
[23:20]	Type	R	0x7	Widget type = Beep Generator
[19:4]	Rsvd1	R	0x0	Reserved
[3]	AmpParOvrd	R	0x1	This widget contains its own amplifier parameters.
[2]	OutAmpPrsnt	R	0x1	Output amp is present

Table 362. PCBEEP WCap Command Response Format

Bit	Bitfield Name	RW	Reset	Description
[1]	InAmpPrsnt	R	0x0	N/A
[0]	Stereo	R	0x0	Mono widget

6.22.3. PCBEEP OutAmpCap

Table 363. PCBEEP OutAmpCap Command Verb Format

	Verb ID	Payload	Response
Get	F00	12	See bitfield table.

Table 364. PCBEEP OutAmpCap Command Response Format

Bit	Bitfield Name	RW	Reset	Description
[31]	Mute	R	0x0	Amplifier is capable of muting
[30:23]	Rsvd3	R	0x0	Reserved
[22:16]	StepSize	R	0x17	Size of each step in the gain range = 6 dB
[15]	Rsvd2	R	0x0	Reserved
[14:8]	NumSteps	R	0x03	Number of steps in the gain range = 4 (-18dB to 0dB)
[7]	Rsvd1	R	0x0	Reserved
[6:0]	Offset	R	0x03	0dB-step is programmed with this offset

6.22.4. PCBEEP Gen

Table 365. PCBEEP Gen Command Verb Format

	Verb ID	Payload	Response
Get	F0A	00	See bitfield table.
Set1	70A	See bits [7:0] of bitfield table.	0000_0000h

Table 366. PCBEEP Gen Command Response Format

Bit	Bitfield Name	RW	Reset	Description
[31:8]	Rsvd	R	0x0	Reserved
[7:0]	Divider	RW	0x0	Enable internal PC-Beep generation. Divider = 00h - disables internal PC Beep generation and enables normal operation of the CODEC. Divider not 00h - generates the beep tone on all Pin Complexes that are currently configured as outputs. The HD Audio spec states that the beep tone frequency = $(48 \text{ KHz HD Audio SYNC rate}) / (4 * \text{Divider})$, producing tones from 47 Hz to 12 KHz (logarithmic scale). Instead, this part generates tones with frequency = $48000 * (257 - \text{Divider}) / 1024$, yielding a linear range from 12 KHz to 93.75 Hz in steps of 46.875 Hz. If JackSenseVSR[Rate2x], then the beep tones generated have frequency = $48000 * (513 - \text{Divider}) / 1024$, yielding a range of 24 KHz to 12093.75 Hz in steps of 46.875 Hz.

6.23. CD Node (NID = 0x12)

6.23.1. CD WCap

Table 367. CD WCap Command Verb Format

	Verb ID	Payload	Response
Get	F00	09	See bitfield table.

Table 368. CD WCap Command Response Format

Bit	Bitfield Name	RW	Reset	Description
[31:24]	Rsvd2	R	0x0	Reserved
[23:20]	Type	R	0x4	Widget type = Pin Complex
[19:16]	Delay	R	0x0	Number of sample delays through widget
[15:12]	Rsvd1	R	0x0	Reserved
[11]	SwapCap	R	0x0	No left/right channel swap capability

Table 368. CD WCap Command Response Format

Bit	Bitfield Name	RW	Reset	Description
[10]	PwrCntrl	R	0x0	No support for Power State control
[9]	Dig	R	0x0	Widget supports an Analog stream
[8]	ConnList	R	0x0	No connection list is present
[7]	UnSolCap	R	0x0	No support for Unsolicited Response
[6]	ProcWidget	R	0x0	No Processing Controls parameter
[5]	Stripe	R	0x0	No support for striping
[4]	FormatOvrd	R	0x0	N/A for pin complex
[3]	AmpParOvrd	R	0x0	No amp
[2]	OutAmpPrsnt	R	0x0	No output amp
[1]	InAmpPrsnt	R	0x0	No input amp
[0]	Stereo	R	0x1	Stereo widget

6.23.2. CD PinCap

Table 369. CD PinCap Command Verb Format

	Verb ID	Payload	Response
Get	F00	0C	See bitfield table.

Table 370. CD PinCap Command Response Format

Bit	Bitfield Name	RW	Reset	Description
[31:17]	Rsvd2	R	0x0	Reserved
[16]	EapdCap	R	0x0	This widget does not control EAPD pin
[15:8]	VrefCntrl	R	0x00	Vref generation not supported on this pin
[7]	Rsvd1	R	0x0	Reserved
[6]	BalancedIO	R	0x0	Pin complex does not have balanced pins.
[5]	InCap	R	0x1	Pin complex is input capable.

Table 370. CD PinCap Command Response Format

Bit	Bitfield Name	RW	Reset	Description
[4]	OutCap	R	0x0	Pin complex is not output capable.
[3]	HdphDrvCap	R	0x0	Pin does not have a headphone amplifier.
[2]	PresDtctCap	R	0x0	Pin complex cannot perform Presence Detect.
[1]	TrigRqd	R	0x0	N/A
[0]	ImpSenseCap	R	0x0	Pin complex does not support impedance sense.

6.23.3. CD PinWCntrl

Table 371. CD PinWCntrl Command Verb Format

	Verb ID	Payload	Response
Get	F07	00	See bitfield table.
Set1	707	See bits [7:0] of bitfield table.	0000_0000h

Table 372. CD PinWCntrl Command Response Format

Bit	Bitfield Name	RW	Reset	Description
[31:6]	Rsvd2	R	0x0	Reserved
[5]	InEn	RW	0x0	1 = (CODEC) input path of Pin Widget is enabled
[4:0]	Rsvd1	R	0x0	Reserved

6.23.4. CD ConfigDefault

Table 373. CD ConfigDefault Command Verb Format

	Verb ID	Payload	Response
Get	F1C	00	See bitfield table.
Set1	71C	See bits [7:0] of bitfield table.	0000_0000h
Set2	71D	See bits [7:0] of bitfield table.	0000_0000h

Table 373. CD ConfigDefault Command Verb Format

	Verb ID	Payload	Response
Set3	71E	See bits [7:0] of bitfield table.	0000_0000h
Set4	71F	See bits [7:0] of bitfield table.	0000_0000h

Table 374. CD ConfigDefault Command Response Format

Bit	Bitfield Name	RW	Reset	Description
[31:24]	Config4	RW	0x50	Port Connectivity = No connect; Location = Internal.
[23:16]	Config3	RW	0x33	Default Device = CD; Connection Type = ATAPI internal.
[15:8]	Config2	RW	0x01	Color = Unknown; Misc = Jack detect override.
[7:0]	Config1	RW	0xF0	Association = Fh; Sequence = 0h.

6.24. VolumeKnob Node (NID = 0x24)

6.24.1. VolumeKnob WCap

Table 375. VolumeKnob WCap Command Verb Format

	Verb ID	Payload	Response
Get	F00	09	See bitfield table.

Table 376. VolumeKnob WCap Command Response Format

Bit	Bitfield Name	RW	Reset	Description
[31:24]	Rsvd2	R	0x0	Reserved
[23:20]	Type	R	0x6 = Enabled 0xF = Disabled	Widget type = Volume Knob Widget
[19:0]	Rsvd1	R	0x0	Reserved. Software assumes capability of unsolicited responses and a connection list for this widget type.

6.24.2. VolumeKnob VolKnobCap

Table 377. VolumeKnob VolKnobCap Command Verb Format

	Verb ID	Payload	Response
Get	F00	13	See bitfield table.

Table 378. VolumeKnob VolKnobCap Command Response Format

Bit	Bitfield Name	RW	Reset	Description
[31:8]	Rsvd	R	0x0	Reserved
[7]	Delta	R	0x1	Indicates if software can write a base volume to the Volume Control Knob.
[6:0]	NumSteps	R	0x7F	Total number of steps in the range of the volume knob = 128

6.24.3. VolumeKnob ConLst

Table 379. VolumeKnob ConLst Command Verb Format

	Verb ID	Payload	Response
Get	F00	0E	See bitfield table.

Table 380. VolumeKnob ConLst Command Response Format

Bit	Bitfield Name	RW	Reset	Description
[31:8]	Rsvd	R	0x0	Reserved.
[7]	LForm	R	0x0	Connection list uses short-form (7-bit) NID entries.
[6:0]	ConL	R	DAC4 enable = 0x05 DAC4 disable = 0x04	Number of NID entries in connection list.

6.24.4. VolumeKnob ConLstEntry0

Table 381. VolumeKnob ConLstEntry0 Command Verb Format

	Verb ID	Payload	Response
Get	F02	00	See bitfield table.

Table 382. VolumeKnob ConLstEntry0 Command Response Format

Bit	Bitfield Name	RW	Reset	Description
[31:24]	ConL3	R	0x05	DAC3
[23:16]	ConL2	R	0x04	DAC2
[15:8]	ConL1	R	0x03	DAC1
[7:0]	ConL0	R	0x02	DAC0

6.24.5. VolumeKnob ConLstEntry4

Table 383. VolumeKnob ConLstEntry4 Command Verb Format

	Verb ID	Payload	Response
Get	F02	04	See bitfield table.

Table 384. VolumeKnob ConLstEntry4 Command Response Format

Bit	Bitfield Name	RW	Reset	Description
[31:24]	ConL7	R	0x0	No connection.
[23:16]	ConL6	R	0x0	No connection.
[15:8]	ConL5	R	0x0	No connection.
[7:0]	ConL4	R	0x06 = Enabled 0x00 = Disabled	DAC4

6.24.6. VolumeKnob UnsolResp

Table 385. VolumeKnob UnsolResp Command Verb Format

	Verb ID	Payload	Response
Get	F08	00	See bitfield table.
Set1	708	See bits [7:0] of bitfield table.	0000_0000h

Table 386. VolumeKnob UnsolResp Command Response Format

Bit	Bitfield Name	RW	Reset	Description
[31:8]	Rsvd2	R	0x00	Reserved
[7]	En	RW	0x0	Allow generation of Unsolicited Responses. Unsolicited response events occur upon jack-insertion OR completion of a Jack-Sense cycle.
[6]	Rsvd1	R	0x0	Reserved
[5:0]	Tag	RW	0x00	Software programmable field returned in top six bits (31:26) of every Unsolicited Response generated by this node.

6.24.7. VolumeKnob Cntrl

Table 387. VolumeKnob Cntrl Command Verb Format

	Verb ID	Payload	Response
Get	F0F	00	See bitfield table.
Set1	70F	See bits [7:0] of bitfield table.	0000_0000h

Table 388. VolumeKnob Cntrl Command Response Format

Bit	Bitfield Name	RW	Reset	Description
[31:8]	Rsvd	R	0x0	Reserved
[7]	Direct	RW	0x0	Direct = 1 causes the volume control to directly control the hardware volume of the slave amps. Direct = 0 causes unsolicited responses to be generated.
[6:0]	Volume	RW	0x7F	Volume, specified in steps of amplifier gain

6.24.8. VolumeKnob VCSR0

Table 389. VolumeKnob VCSR0 Command Verb Format

	Verb ID	Payload	Response
Get	FE0	00	See bitfield table.
Set1	7E0	See bits [7:0] of bitfield table.	0000_0000h

Table 390. VolumeKnob VCSR0 Command Response Format

Bit	Bitfield Name	RW	Reset	Description
[31:4]	Rsvd	R	0x0	Reserved
[3]	Continuous	RW	0x1	Allow continuous incrementing/ decrementing of the volume knob value.
[2:0]	Rate	RW	0x0	Volume knob update rate, for continuous mode and de-bouncing (2.5 Hz to 20 Hz, in increments of 2.5 Hz)

6.25. InPort0Vol Node (NID = 0x18)

6.25.1. InPort0Vol WCap

Table 391. InPort0Vol WCap Command Verb Format

	Verb ID	Payload	Response
Get	F00	09	See bitfield table.

Table 392. InPort0Vol WCap Command Response Format

Bit	Bitfield Name	RW	Reset	Description
[31:24]	Rsvd2	R	0x0	Reserved
[23:20]	Type	R	0x3	Widget type = Audio Selector
[19:16]	Delay	R	0x0	Number of sample delays through widget
[15:12]	Rsvd1	R	0x0	Reserved
[11]	SwapCap	R	0x0	No left/right channel swap capability
[10]	PwrCntrl	R	0x0	No support for Power State control
[9]	Dig	R	0x0	Widget supports an Analog stream
[8]	ConnList	R	0x1	Connection list is present
[7]	UnSolCap	R	0x0	No support for Unsolicited Response
[6]	ProcWidget	R	0x0	No Processing Controls parameter.
[5]	Stripe	R	0x0	No support for striping

Table 392. InPort0Vol WCap Command Response Format

Bit	Bitfield Name	RW	Reset	Description
[4]	FormatOvrd	R	0x0	No format info; use default format parameters from Audio Function node instead
[3]	AmpParOvrd	R	0x0	No amplifier info; use default amplifier parameters from Audio Function node instead
[2]	OutAmpPrsnt	R	0x0	No output amp
[1]	InAmpPrsnt	R	0x1	input amp is present
[0]	Stereo	R	0x1	Stereo widget

6.25.2. InPort0Vol ConLst

Table 393. InPort0Vol ConLst Command Verb Format

	Verb ID	Payload	Response
Get	F00	0E	See bitfield table.

Table 394. InPort0Vol ConLst Command Response Format

Bit	Bitfield Name	RW	Reset	Description
[31:8]	Rsvd	R	0x0	Reserved
[7]	LForm	R	0x0	Connection list uses short-form (7-bit) NID entries.
[6:0]	ConL	R	0x01	Number of NID entries in connection list.

6.25.3. InPort0Vol InAmpRight

Table 395. InPort0Vol InAmpRight Command Verb Format

	Verb ID	Payload	Response
Get	B00	00	See bitfield table.
Set1	350	See bits [7:0] of bitfield table.	0000_0000h

Table 396. InPort0Vol InAmpRight Command Response Format

Bit	Bitfield Name	RW	Reset	Description
[31:4]	Rsvd1	R	0x0	Reserved
[3:0]	Gain	RW	0x0	Amplifier gain step number

6.25.4. InPort0Vol InAmpLeft

Table 397. InPort0Vol InAmpLeft Command Verb Format

	Verb ID	Payload	Response
Get	B20	00	See bitfield table.
Set1	360	See bits [7:0] of bitfield table.	0000_0000h

Table 398. InPort0Vol InAmpLeft Command Response Format

Bit	Bitfield Name	RW	Reset	Description
[31:4]	Rsvd1	R	0x0	Reserved
[3:0]	Gain	RW	0x0	Amplifier gain step number

6.25.5. InPort0Vol ConLstEntry

Table 399. InPort0Vol ConLstEntry Command Verb Format

	Verb ID	Payload	Response
Get	F02	00	See bitfield table.

Table 400. InPort0Vol ConLstEntry Command Response Format

Bit	Bitfield Name	RW	Reset	Description
[31:24]	ConL3	R	0x00	No Connection
[23:16]	ConL2	R	0x00	No Connection
[15:8]	ConL1	R	0x00	No Connection
[7:0]	ConL0	R	0x15	InPort0 Mux widget

6.26. InPort1Vol Node (NID = 0x19)

6.26.1. InPort1Vol WCap

Table 401. InPort1Vol WCap Command Verb Format

	Verb ID	Payload	Response
Get	F00	09	See bitfield table.

Table 402. InPort1Vol WCap Command Response Format

Bit	Bitfield Name	RW	Reset	Description
[31:24]	Rsvd2	R	0x0	Reserved
[23:20]	Type	R	0x3	Widget type = Audio Selector
[19:16]	Delay	R	0x0	Number of sample delays through widget
[15:12]	Rsvd1	R	0x0	Reserved
[11]	SwapCap	R	0x0	No left/right channel swap capability
[10]	PwrCntrl	R	0x0	No support for Power State control
[9]	Dig	R	0x0	Widget supports an Analog stream
[8]	ConnList	R	0x1	Connection list is present
[7]	UnSolCap	R	0x0	No support for Unsolicited Response
[6]	ProcWidget	R	0x0	No Processing Controls parameter.
[5]	Stripe	R	0x0	No support for striping
[4]	FormatOvrd	R	0x0	No format info; use default format parameters from Audio Function node instead
[3]	AmpParOvrd	R	0x0	No amplifier info; use default amplifier parameters from Audio Function node instead
[2]	OutAmpPrsnt	R	0x0	No output amp
[1]	InAmpPrsnt	R	0x1	input amp is present
[0]	Stereo	R	0x1	Stereo widget

6.26.2. InPort1Vol ConLst**Table 403. InPort1Vol ConLst Command Verb Format**

	Verb ID	Payload	Response
Get	F00	0E	See bitfield table.

Table 404. InPort1Vol ConLst Command Response Format

Bit	Bitfield Name	RW	Reset	Description
[31:8]	Rsvd	R	0x0	Reserved
[7]	LForm	R	0x0	Connection list uses short-form (7-bit) NID entries.
[6:0]	ConL	R	0x01	Number of NID entries in connection list.

6.26.3. InPort1Vol InAmpRight**Table 405. InPort1Vol InAmpRight Command Verb Format**

	Verb ID	Payload	Response
Get	B00	00	See bitfield table.
Set1	350	See bits [7:0] of bitfield table.	0000_0000h

Table 406. InPort1Vol InAmpRight Command Response Format

Bit	Bitfield Name	RW	Reset	Description
[31:4]	Rsvd1	R	0x0	Reserved
[3:0]	Gain	RW	0x0	Amplifier gain step number

6.26.4. InPort1Vol InAmpLeft**Table 407. InPort1Vol InAmpLeft Command Verb Format**

	Verb ID	Payload	Response
Get	B20	00	See bitfield table.
Set1	360	See bits [7:0] of bitfield table.	0000_0000h

Table 408. InPort1Vol InAmpLeft Command Response Format

Bit	Bitfield Name	RW	Reset	Description
[31:4]	Rsvd1	R	0x0	Reserved
[3:0]	Gain	RW	0x0	Amplifier gain step number

6.26.5. InPort1Vol ConLstEntry

Table 409. InPort1Vol ConLstEntry Command Verb Format

	Verb ID	Payload	Response
Get	F02	00	See bitfield table.

Table 410. InPort1Vol ConLstEntry Command Response Format

Bit	Bitfield Name	RW	Reset	Description
[31:24]	ConL3	R	0x00	No Connection
[23:16]	ConL2	R	0x00	No Connection
[15:8]	ConL1	R	0x00	No Connection
[7:0]	ConL0	R	0x16	InPort1Mux widget

6.27. ADC0Mux Node (NID = 0x1B)

6.27.1. ADC0Mux WCap

Table 411. ADC0Mux WCap Command Verb Format

	Verb ID	Payload	Response
Get	F00	09	See bitfield table.

Table 412. ADC0Mux WCap Command Response Format

Bit	Bitfield Name	RW	Reset	Description
[31:24]	Rsvd2	R	0x0	Reserved
[23:20]	Type	R	0x3	Widget type = Audio Selector
[19:16]	Delay	R	0x0	Number of sample delays through widget

Table 412. ADC0Mux WCap Command Response Format

Bit	Bitfield Name	RW	Reset	Description
[15:12]	Rsvd1	R	0x0	Reserved
[11]	SwapCap	R	0x1	Left and right channels can be swapped
[10]	PwrCntrl	R	0x0	No support for Power State control
[9]	DigitalStrm	R	0x0	Widget supports an Analog stream
[8]	ConnList	R	0x1	Connection list is present
[7]	UnsolCap	R	0x0	No support for Unsolicited Response
[6]	ProcWidget	R	0x0	No Processing Controls parameter.
[5]	Stripe	R	0x0	No support for striping
[4]	FormatOvrd	R	0x0	No format info; use default format parameters from Audio Function node instead
[3]	AmpParamOvrd	R	0x1	This widget contains its own amplifier parameters.
[2]	OutAmpPrsnt	R	0x1	Output amp is present
[1]	InAmpPrsnt	R	0x0	No input amp
[0]	Stereo	R	0x1	Stereo widget

6.27.2. ADC0Mux ConLst

Table 413. ADC0Mux ConLst Command Verb Format

	Verb ID	Payload	Response
Get	F00	0E	See bitfield table.

Table 414. ADC0Mux ConLst Command Response Format

Bit	Bitfield Name	RW	Reset	Description
[31:8]	Rsvd	R	0x0	Reserved

Table 414. ADC0Mux ConLst Command Response Format

Bit	Bitfield Name	RW	Reset	Description
[7]	LForm	R	0x0	Connection list uses short-form (7-bit) NID entries.
[6:0]	ConL	R	0x03 = Enabled 0x01 = Disabled	Number of NID entries in connection list.

6.27.3. ADC0Mux ConSelectCtrl

Table 415. ADC0Mux ConSelectCtrl Command Verb Format

	Verb ID	Payload	Response
Get	F01	00	See bitfield table.
Set1	701	See bits [7:0] of bitfield table.	0000_0000h

Table 416. ADC0Mux ConSelectCtrl Command Response Format

Bit	Bitfield Name	RW	Reset	Description
[31:2]	Rsvd	R	0x0	Reserved
[1:0]	Index	RW	0x0	Connection select control index.

6.27.4. ADC0Mux ConLstEntry

Table 417. ADC0Mux ConLstEntry Command Verb Format

	Verb ID	Payload	Response
Get	F02	00	See bitfield table.

Table 418. ADC0Mux ConLstEntry Command Response Format

Bit	Bitfield Name	RW	Reset	Description
[31:24]	ConL3	R	0x00	No connection
[23:16]	ConL2	R	0x14 = Enabled 0x00 = Disabled	DMic1 pin widget
[15:8]	ConL1	R	0x13 = Enabled 0x00 = Disabled	DMic0 pin widget
[7:0]	ConL0	R	0x18	InPort0Vol widget

6.27.5. *ADC0Mux LR*

Table 419. ADC0Mux LR Command Verb Format

	Verb ID	Payload	Response
Get	F0C	00	See bitfield table.
Set1	70C	See bits [7:0] of bitfield table.	0000_0000h

Table 420. ADC0Mux LR Command Response Format

Bit	Bitfield Name	RW	Reset	Description
[31:3]	Rsvd2	R	0x0	Reserved
[2]	SwapEn	RW	0x0	1 = swap left and right channels of this Widget.
[1:0]	Rsvd1	R	0x0	Reserved

6.27.6. *ADC0Mux OutAmpCap*

Table 421. ADC0Mux OutAmpCap Command Verb Format

	Verb ID	Payload	Response
Get	F00	12	See bitfield table.

Table 422. ADC0Mux OutAmpCap Command Response Format

Bit	Bitfield Name	RW	Reset	Description
[31]	Mute	R	0x1	Amplifier is capable of muting
[30:23]	Rsvd3	R	0x0	Reserved
[22:16]	StepSize	R	0x00	Size of each step in the gain range, N/A since there are no steps
[15]	Rsvd2	R	0x0	Reserved
[14:8]	NumSteps	R	0x00	No steps, gain is fixed at 0dB
[7]	Rsvd1	R	0x0	Reserved
[6:0]	Offset	R	0x00	0dB-step is programmed with this offset

6.27.7. ADC0Mux OutAmpRight**Table 423. ADC0Mux OutAmpRight Command Verb Format**

	Verb ID	Payload	Response
Get	B80	00	See bitfield table.
Set1	390	See bits [7:0] of bitfield table.	0000_0000h

Table 424. ADC0Mux OutAmpRight Command Response Format

Bit	Bitfield Name	RW	Reset	Description
[31:8]	Rsvd2	R	0x0	Reserved
[7]	Mute	RW	0x1	1 = mute is active
[6:0]	Rsvd1	R	0x0	Reserved

6.27.8. ADC0Mux OutAmpLeft**Table 425. ADC0Mux OutAmpLeft Command Verb Format**

	Verb ID	Payload	Response
Get	BA0	00	See bitfield table.
Set1	3A0	See bits [7:0] of bitfield table.	0000_0000h

Table 426. ADC0Mux OutAmpLeft Command Response Format

Bit	Bitfield Name	RW	Reset	Description
[31:8]	Rsvd2	R	0x0	Reserved
[7]	Mute	RW	0x1	1 = mute is active
[6:0]	Rsvd1	R	0x0	Reserved

6.28. ADC1Mux Node (NID = 0x1C)**6.28.1. ADC1Mux WCap****Table 427. ADC1Mux WCap Command Verb Format**

	Verb ID	Payload	Response
Get	F00	09	See bitfield table.

Table 428. ADC1Mux WCap Command Response Format

Bit	Bitfield Name	RW	Reset	Description
[31:24]	Rsvd2	R	0x0	Reserved
[23:20]	Type	R	0x3	Widget type = Audio Selector
[19:16]	Delay	R	0x0	Number of sample delays through widget
[15:12]	Rsvd1	R	0x0	Reserved
[11]	SwapCap	R	0x1	Left and right channels can be swapped
[10]	PwrCntrl	R	0x0	No support for Power State control
[9]	DigitalStrm	R	0x0	Widget supports an Analog stream
[8]	ConnList	R	0x1	Connection list is present
[7]	UnsolCap	R	0x0	No support for Unsolicited Response
[6]	ProcWidget	R	0x0	No Processing Controls parameter.
[5]	Stripe	R	0x0	No support for striping
[4]	FormatOvrd	R	0x0	No format info; use default format parameters from Audio Function node instead
[3]	AmpParamOvrd	R	0x1	This widget contains its own amplifier parameters.
[2]	OutAmpPrsnt	R	0x1	Output amp is present
[1]	InAmpPrsnt	R	0x0	No input amp
[0]	Stereo	R	0x1	Stereo widget

6.28.2. ADC1Mux ConLst

Table 429. ADC1Mux ConLst Command Verb Format

	Verb ID	Payload	Response
Get	F00	0E	See bitfield table.

Table 430. ADC1Mux ConLst Command Response Format

Bit	Bitfield Name	RW	Reset	Description
[31:8]	Rsvd	R	0x0	Reserved
[7]	LForm	R	0x0	Connection list uses short-form (7-bit) NID entries.
[6:0]	ConL	R	0x03 = Enabled 0x01 = Disabled	Number of NID entries in connection list.

6.28.3. ADC1Mux ConSelectCtrl

Table 431. ADC1Mux ConSelectCtrl Command Verb Format

	Verb ID	Payload	Response
Get	F01	00	See bitfield table.
Set1	701	See bits [7:0] of bitfield table.	0000_0000h

Table 432. ADC1Mux ConSelectCtrl Command Response Format

Bit	Bitfield Name	RW	Reset	Description
[31:2]	Rsvd	R	0x0000_0000	Reserved
[1:0]	Index	RW	0x0	Connection select control index.

6.28.4. ADC1Mux ConLstEntry

Table 433. ADC1Mux ConLstEntry Command Verb Format

	Verb ID	Payload	Response
Get	F02	00	See bitfield table.

Table 434. ADC1Mux ConLstEntry Command Response Format

Bit	Bitfield Name	RW	Reset	Description
[31:24]	ConL3	R	0x00	No connection
[23:16]	ConL2	R	0x14 = Enabled 0x00 = Disabled	DMic1 pin widget

Table 434. ADC1Mux ConLstEntry Command Response Format

Bit	Bitfield Name	RW	Reset	Description
[15:8]	ConL1	R	0x13 = Enabled 0x00 = Disabled	DMic0 pin widget
[7:0]	ConL0	R	0x19	InPort1Vol widget

6.28.5. ADC1Mux LR

Table 435. ADC1Mux LR Command Verb Format

	Verb ID	Payload	Response
Get	F0C	00	See bitfield table.
Set1	70C	See bits [7:0] of bitfield table.	0000_0000h

Table 436. ADC1Mux LR Command Response Format

Bit	Bitfield Name	RW	Reset	Description
[31:3]	Rsvd2	R	0x0	Reserved
[2]	SwapEn	RW	0x0	1 = swap left and right channels of this Widget.
[1:0]	Rsvd1	R	0x0	Reserved

6.28.6. ADC1Mux OutAmpCap

Table 437. ADC1Mux OutAmpCap Command Verb Format

	Verb ID	Payload	Response
Get	F00	12	See bitfield table.

Table 438. ADC1Mux OutAmpCap Command Response Format

Bit	Bitfield Name	RW	Reset	Description
[31]	Mute	R	0x1	Amplifier is capable of muting
[30:23]	Rsvd3	R	0x0	Reserved
[22:16]	StepSize	R	0x00	Size of each step in the gain range, N/A since there are no steps
[15]	Rsvd2	R	0x0	Reserved

Table 438. ADC1Mux OutAmpCap Command Response Format

Bit	Bitfield Name	RW	Reset	Description
[14:8]	NumSteps	R	0x00	No steps, gain is fixed at 0dB
[7]	Rsvd1	R	0x0	Reserved
[6:0]	Offset	R	0x00	0dB-step is programmed with this offset

6.28.7. ADC1Mux OutAmpRight

Table 439. ADC1Mux OutAmpRight Command Verb Format

	Verb ID	Payload	Response
Get	B80	00	See bitfield table.
Set1	390	See bits [7:0] of bitfield table.	0000_0000h

Table 440. ADC1Mux OutAmpRight Command Response Format

Bit	Bitfield Name	RW	Reset	Description
[31:8]	Rsvd2	R	0x0	Reserved
[7]	Mute	RW	0x1	1 = mute is active
[6:0]	Rsvd1	R	0x0	Reserved

6.28.8. ADC1Mux OutAmpLeft

Table 441. ADC1Mux OutAmpLeft Command Verb Format

	Verb ID	Payload	Response
Get	BA0	00	See bitfield table.
Set1	3A0	See bits [7:0] of bitfield table.	0000_0000h

Table 442. ADC1Mux OutAmpLeft Command Response Format

Bit	Bitfield Name	RW	Reset	Description
[31:8]	Rsvd2	R	0x0	Reserved
[7]	Mute	RW	0x1	1 = mute is active
[6:0]	Rsvd1	R	0x0	Reserved

7. ORDERING INFORMATION

7.1. 92HD206 Family Options and Part Order Numbers

Part Order Number	Voltage	DAC SNR	Dolby	Pkg Pins
92HD206XX5PRGXyyX	5 V	95dB	No	48 LQFP
92HD206DX5PRGXyyX	5 V	95dB	Home Theater/Sound Room	48 LQFP

NOTE: When ordering these parts the “yy” will be replaced with the CODEC revision. Add an “8” to the end of any of these part numbers for delivery on Tape and Reel. The minimum order quantity for Tape and Reel is 2,000 units.

8. PIN INFORMATION

8.1. 92HD206 48-Pin LQFP Diagram

Figure 3. 48-Pin LQFP Pinout

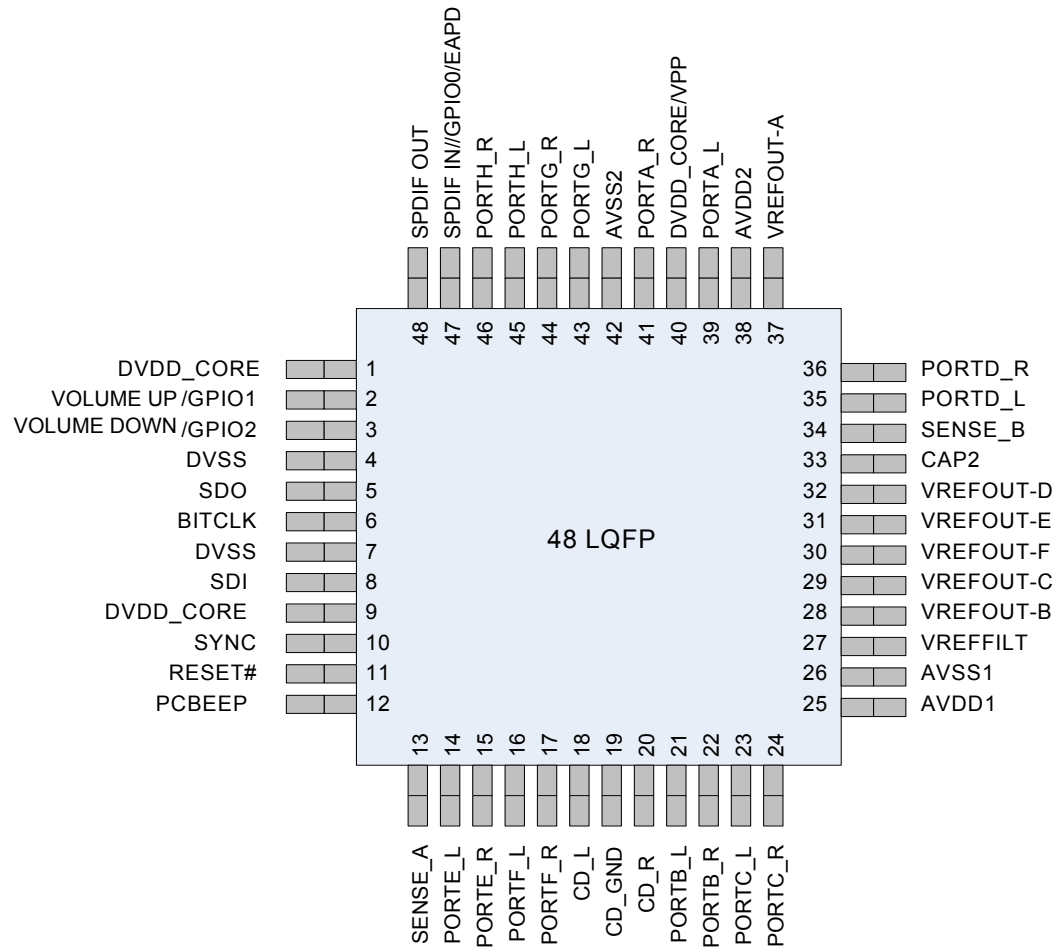

8.2. Pin Table for 92HD206 in 48 Pin LQFP

Pin Name	Pin Function	I/O	Internal Pull-up/ Pull-down	Pin Location
DVDD_CORE	Digital Vdd = 3.3 V	I(Digital)	None	1
Volume Up/GPIO1	Volume Control OR General Purpose I/O	I/O(Digital)	Pull-up 50 K Ω	2

Pin Name	Pin Function	I/O	Internal Pull-up/ Pull-down	Pin Location
Volume Down/GPIO2	Volume Control OR General Purpose I/O	I/O(Digital)	Pull-up 50 K Ω	3
DVSS	Digital Ground	I(Digital)	None	4
SDATA_OUT	HD Audio Serial Data output (inbound stream)	I/O(Digital)	None	5
BIT_CLK	HD Audio Bit Clock	I(Digital)	None	6
DVSS3	Digital Ground	I(Digital)	None	7
SDATA_IN	HD Audio Serial Data (outbound stream)	O(Digital)	None	8
DVDD_CORE	Digital Vdd = 3.3 V	I(Digital)	None	9
SYNC	HD Audio Frame Sync	I(Digital)	None	10
RESET#	HD Audio Reset	I(Digital)	None	11
PCBEEP	PC BEEP	I(Analog)	None	12
SENSE_A	Jack insertion detection Ports A, B, C, D	I(Analog)	None	13
PORT-E_L	Input/Output of Left DAC2	I/O(Analog)	None	14
PORT-E_R	Input/Output of Right DAC2	I/O(Analog)	None	15
PORT-F_L	Input/Output of Left DAC3	I/O(Analog)	None	16
PORT-F_R)	Input/Output of Right DAC3	I/O(Analog)	None	17
CD-L	CD Audio Left Channel	I(Analog)	None	18
CD-GND	CD Audio Analog Ground	I(Analog)	None	19
CD-R	CD Audio Right Channel	I(Analog)	None	20
PORT-B_L (HP)	Input/Output of Left DAC0, 3, 4	I/O(Analog)	None	21
PORT-B_R (HP)	Input/Output of Right DAC0, 3, 4	I/O(Analog)	None	22
PORT-C_L	Input/Output of Left DAC1	I/O(Analog)	None	23
PORT-C_R	Input/Output of Right DAC1	I/O(Analog)	None	24
AVDD1	Analog Vdd = 5 V	I(Analog)	None	25
AVSS1	Analog Ground	I(Analog)	None	26
VREF FILT	Analog Virtual Ground	O(Analog)	None	27
VREFOUT-B	Reference Voltage out drive (intended for mic bias) for Port B	O(Analog)	None	28
VREFOUT-C	Reference Voltage out drive (intended for mic bias) for Port C	O(Analog)	None	29
VREFOUT-F	Reference Voltage out drive (intended for mic bias) for Port F	O(Analog)	None	30
VREFOUT-E	Reference Voltage out drive (intended for mic bias) for Port E	O(Analog)	None	31

Pin Name	Pin Function	I/O	Internal Pull-up/ Pull-down	Pin Location
VREFOUT-D	Reference Voltage out drive (intended for mic bias) for Port D	O(Analog)	None	32
CAP2	ADC reference Cap	O(Analog)	None	33
SENSE_B	Jack insertion detection Ports E, F, G, H	I(Analog)	None	34
PORT-D_L (HP)	Input/Output of Left DAC0	I/O(Analog)	None	35
PORT-D_R (HP)	Input/Output of Right DAC0	I/O(Analog)	None	36
VREFOUT-A	Reference Voltage out drive (ntended for mic bias) for Port A	O(Analog)	None	37
AVDD2	Analog Vdd = 5 V	I(Analog)	None	38
PORT-A_L (HP)	Input/Output of Left DAC0, 3, 4	I/O(Analog)	None	39
DVDD_CORE	Digital Vdd = 3.3 V	I(Digital)	None	40
PORT-A_R (HP)	Input/Output of Right DAC0, 3, 4	I/O(Analog)	None	41
AVSS3	Analog Ground	I(Analog)	None	42
PORT-G_L	Input/Output of Left DAC2	I/O(Analog)	None	43
PORT-G_R	Input/Output of Right DAC2	I/O(Analog)	None	44
PORT-H_L	Input/Output of Left DAC1	I/O(Analog)	None	45
PORT-H_R	Input/Output of Right DAC1	I/O(Analog)	None	46
SPDIFIN/GPIO0/EAPD	SPDIF Input, General Purpose I/O, EAPD	I/O(Digital)	Pull-up 50 K Ω or more	47
S/PDIF_OUT	SPDIF Digital Output (50 K Ω internal pull-down)	O(Digital)	50 K Ω internal pull-down	48

9. PACKAGE OUTLINE AND PACKAGE DIMENSIONS

Package dimensions are kept current with JEDEC Publication No. 95

9.1. 48-Pin LQFP

Figure 4. 48-Pin LQFP Package Outline and Package Dimensions

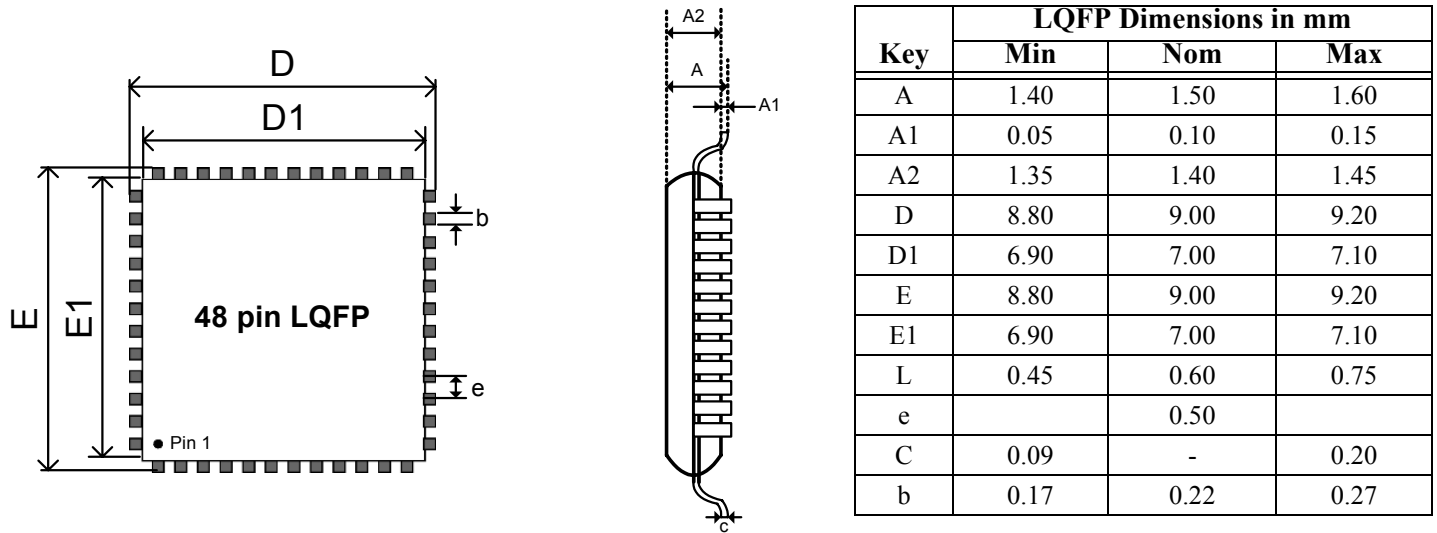

10. SOLDER REFLOW PROFILE

10.1. Standard Reflow Profile Data

Note: These devices can be hand soldered at 360 °C for 3 to 5 seconds.

FROM: IPC / JEDEC J-STD-020C "Moisture/Reflow Sensitivity Classification for Nonhermetic Solid State Surface Mount Devices" (www.jedec.org/download).

Profile Feature	Pb Free Assembly
Average Ramp-Up Rate ($T_{s_{max}} - T_p$)	3 °C / second max
Preheat Temperature Min ($T_{s_{min}}$) Temperature Max ($T_{s_{max}}$) Time ($t_{s_{min}} - t_{s_{max}}$)	150 °C 200 °C 60 - 180 seconds
Time maintained above Temperature (T_L) Time (t_L)	217 °C 60 - 150 seconds
Peak / Classification Temperature (T_p)	See "Package Classification Reflow Temperatures" on page 174.
Time within 5 °C of actual Peak Temperature (t_p)	20 - 40 seconds
Ramp-Down rate	6 °C / second max
Time 25 °C to Peak Temperature	8 minutes max

Note: All temperatures refer to topside of the package, measured on the package body surface.

Figure 5. Solder Reflow Profile

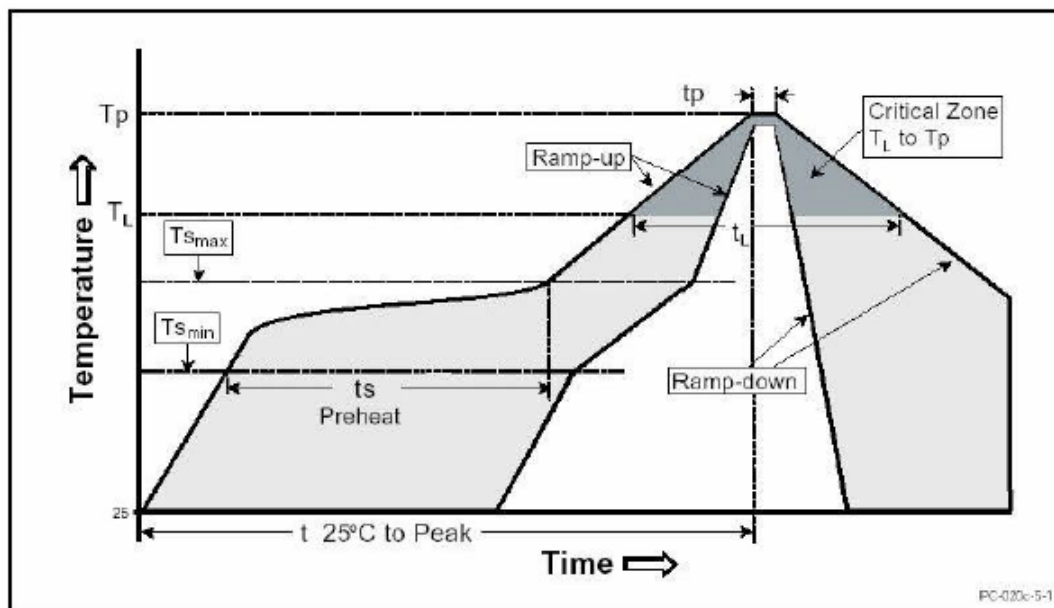

10.2. Pb Free Process - Package Classification Reflow Temperatures

Package Type	MSL	Reflow Temperature
LQFP 48-pin	3	260 °C

11. REVISION HISTORY

Revision	Date	Description of Change
1.0	9 November 2006	Initial release.
1.1	14 November 2006	Update Section reference in Table 6.
1.2	20 November 2006	Remove erroneous references to ADAT in Widget List and Widget Diagram. Remove erroneous reference to 3.3 V analog operation.

Innovate with IDT audio for high fidelity. Contact:

www.IDT.com

For Sales

800-345-7015
408-284-8200
Fax: 408-284-2775

For Tech Support

HA.CM@idt.com

Corporate Headquarters

Integrated Device Technology, Inc.
6024 Silver Creek Valley Road
San Jose, CA 95138
United States
800 345 7015
+408 284 8200 (outside U.S.)

Europe

IDT Europe, Limited
Prime House
Barnett Wood Lane
Leatherhead, Surrey
United Kingdom KT22 7DE
+44 1372 363 339



Looking for pricing, stock, or lifecycle information?

Click below to explore more details on WIN SOURCE:

- ⊖ [View IDT92HD206XX5PRGXB4X on WIN SOURCE](#)
- ⊖ [IDT, Integrated Device Technology Inc Information](#)

Optimize Your Supply Chain with WIN SOURCE Solutions

- ✓ Global Sourcing Solution
- ✓ Obsolete Management
- ✓ Cost Control Management
- ✓ Shortage Management
- ✓ Alternative Solution
- ✓ Excess Inventory Management