



**THE DATASHEET OF
C3D02065E**



C3D02065E

650 V, 2 A Silicon Carbide Schottky Diode



TO-252-2



Features

- 650-Volt Schottky rectifier
- Optimized for PFC boost diode application
- Zero reverse recovery current
- Zero forward recovery voltage
- High-frequency operation
- Temperature-independent switching behavior
- Extremely fast switching
- Positive temperature coefficient on V_f



Package Types: TO-252-2

Marking: C3D02065

WolfSpeed, Inc. is in the process of rebranding its products and related materials pursuant to the entity name change from Cree, Inc. to WolfSpeed, Inc. During this transition period, products received may be marked with either the Cree name and/or logo or the WolfSpeed name and/or logo.

Typical Applications

- Switch mode power supplies (SMPS)
- Boost diodes in PFC or DC/DC stages
- Free wheeling diodes in inverter stages
- AC/DC converters

Benefits

- Replace bipolar with unipolar rectifiers
- Essentially no switching losses
- Higher efficiency
- Reduction of heat sink requirements
- Parallel devices without thermal runaway

Maximum Ratings ($T_c = 25^\circ\text{C}$ Unless Otherwise Specified)

Parameter	Symbol	Value	Unit	Test Conditions	Note
Repetitive Peak Reverse Voltage	V_{RRM}	650	V		
Surge Peak Reverse Voltage	V_{RSM}	650			
DC Blocking Voltage	V_{DC}	650			
Continuous Forward Current	I_F	8	A	$T_c = 25^\circ\text{C}$	Fig. 3
		4		$T_c = 135^\circ\text{C}$	
		2		$T_c = 161^\circ\text{C}$	
Repetitive Peak Forward Surge Current	I_{FRM}	11	A	$T_c = 25^\circ\text{C}$, $t_p = 10$ ms, Half Sine Pulse	Fig. 8
		7.5		$T_c = 110^\circ\text{C}$, $t_p = 10$ ms, Half Sine Pulse	
Non-Repetitive Peak Forward Surge Current	I_{FSM}	16.5	A	$T_c = 25^\circ\text{C}$, $t_p = 10$ ms, Half Sine Pulse	Fig. 8
		15		$T_c = 110^\circ\text{C}$, $t_p = 10$ ms, Half Sine Pulse	
Non-Repetitive Peak Forward Surge Current	I_{FSM}	120	A	$T_c = 25^\circ\text{C}$, $t_p = 10$ μs , Pulse	Fig. 8
		110		$T_c = 110^\circ\text{C}$, $t_p = 10$ μs , Pulse	
Power Dissipation	P_{tot}	39.5	W	$T_c = 25^\circ\text{C}$	Fig. 4
		17		$T_c = 110^\circ\text{C}$	
Diode dV/dt Ruggedness	dV/dt	200	V/ns	$V_R = 0-650$ V	
i^2t Value	$\int i^2 dt$	1.35	A^2s	$T_c = 25^\circ\text{C}$, $t_p = 10$ ms	
		1.12		$T_c = 110^\circ\text{C}$, $t_p = 10$ ms	
Operating Junction and Storage Temperature	T_J, T_{stg}	-55 to +175	$^\circ\text{C}$		



Electrical Characteristics

Parameter	Symbol	Typ.	Max.	Unit	Test Conditions	Note
Forward Voltage	V_F	1.5	1.7	V	$I_F = 2 \text{ A}, T_J = 25 \text{ }^\circ\text{C}$	Fig. 1
		1.8	2.4		$I_F = 2 \text{ A}, T_J = 175 \text{ }^\circ\text{C}$	
Reverse Current	I_R	3.5	18	μA	$V_R = 650 \text{ V}, T_J = 25 \text{ }^\circ\text{C}$	Fig. 2
		7.5	60		$V_R = 650 \text{ V}, T_J = 175 \text{ }^\circ\text{C}$	
Total Capacitive Charge	Q_C	5.8		nC	$V_R = 400 \text{ V}, I_F = 2 \text{ A}$ $di/dt = 500 \text{ A}/\mu\text{S}$ $T_J = 25 \text{ }^\circ\text{C}$	Fig. 5
Total Capacitance	C	175		pF	$V_R = 0 \text{ V}, T_J = 25 \text{ }^\circ\text{C}, f = 1 \text{ MHz}$	Fig. 6
		10.5			$V_R = 200 \text{ V}, T_J = 25 \text{ }^\circ\text{C}, f = 1 \text{ MHz}$	
		8.5			$V_R = 400 \text{ V}, T_J = 25 \text{ }^\circ\text{C}, f = 1 \text{ MHz}$	
Capacitance Stored Energy	E_C	0.8		μJ	$V_R = 400 \text{ V}$	Fig. 7

Note: This is a majority carrier diode, so there is no reverse recovery charge.

Thermal Characteristics

Parameter	Symbol	Typ.	Unit
TO-252 Package Thermal Resistance from Junction to Case	$R_{\theta JC}$	3.8	$^\circ\text{C}/\text{W}$

Typical Performance

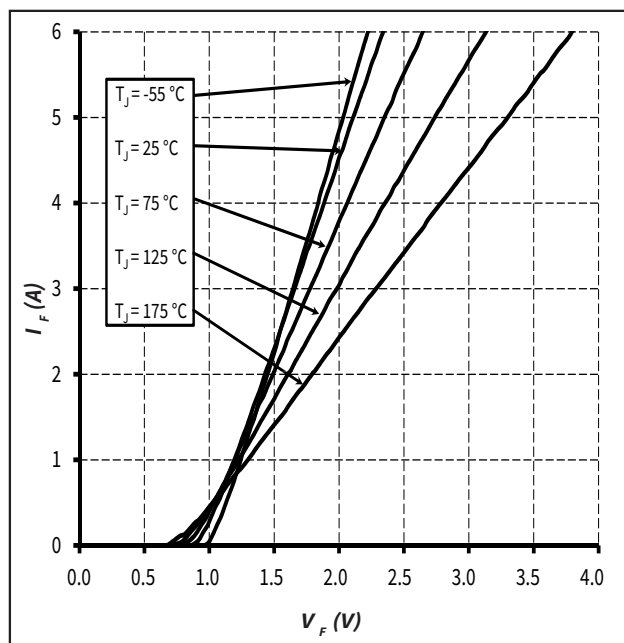

Figure 1. Forward Characteristics

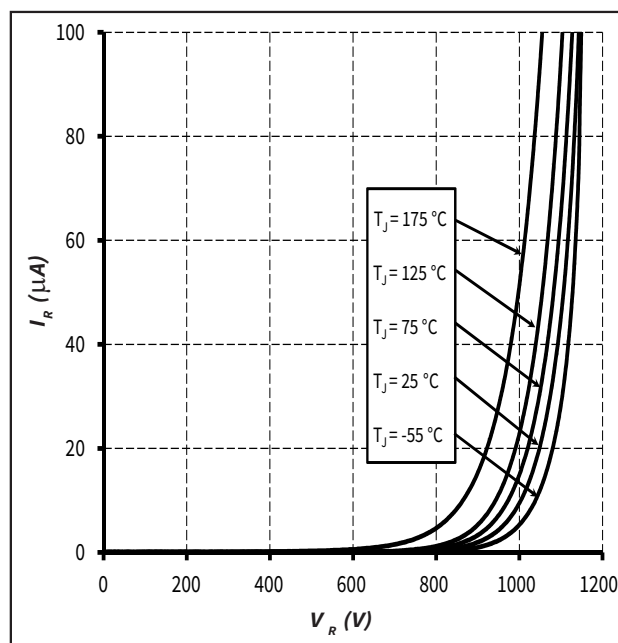

Figure 2. Reverse Characteristics



Typical Performance

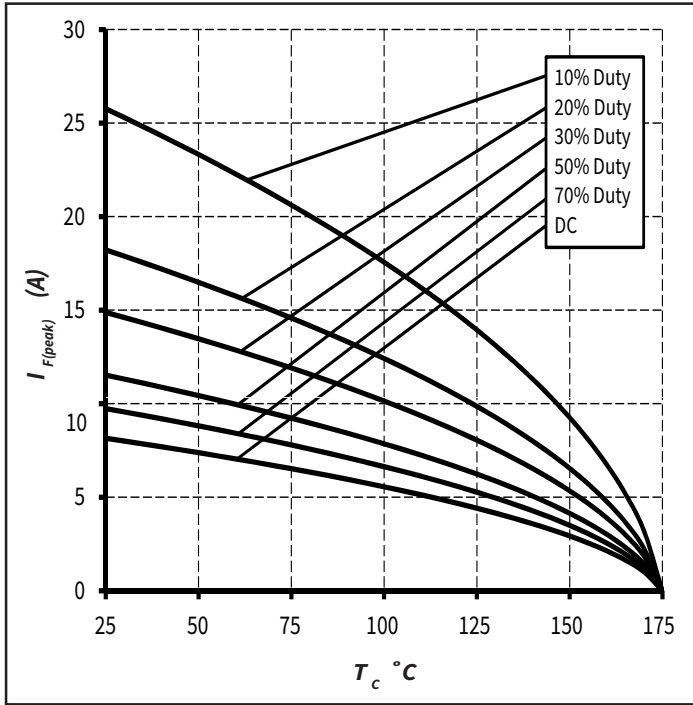

Figure 3. Current Derating

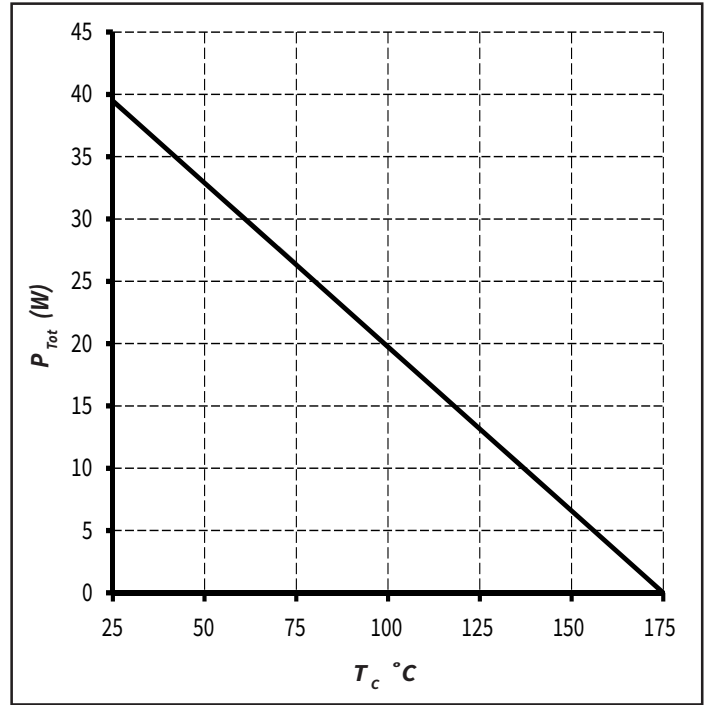

Figure 4. Power Derating

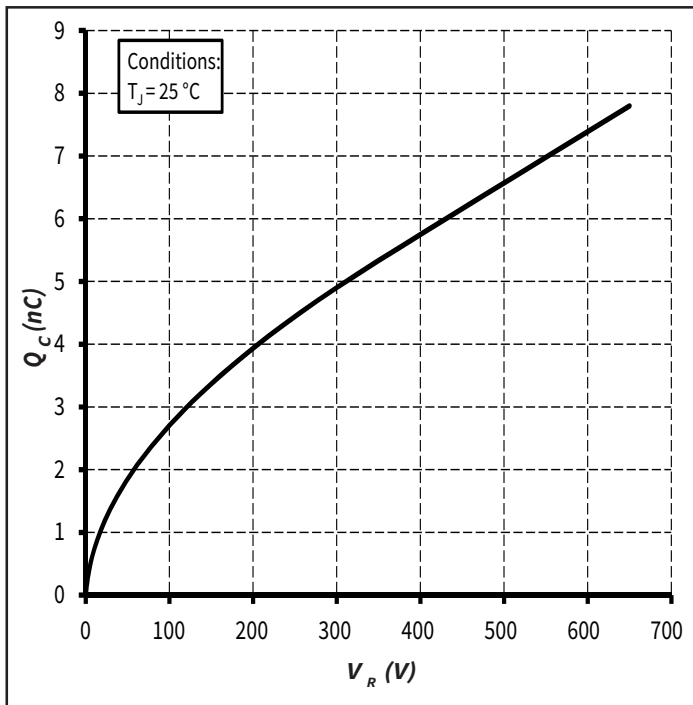

Figure 5. Total Capacitance Charge vs. Reverse Voltage

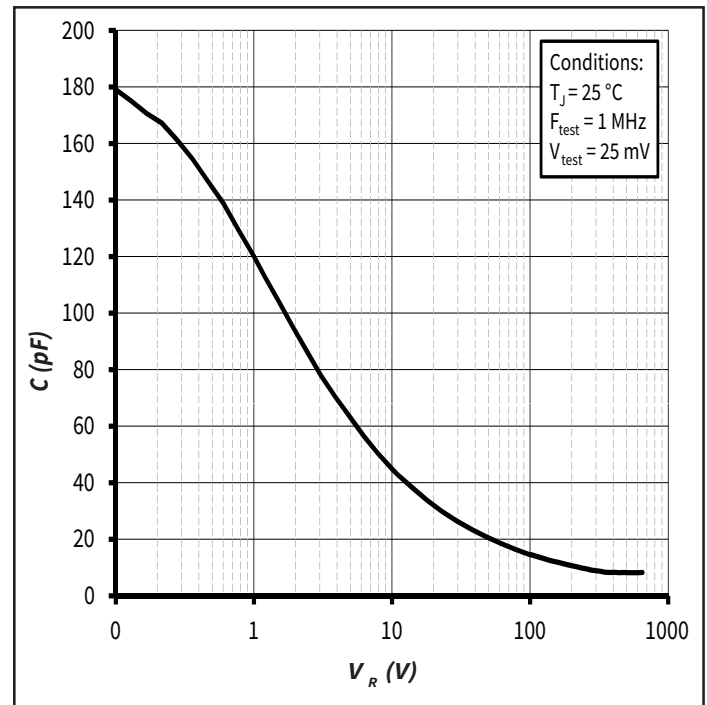

Figure 6. Capacitance vs. Reverse Voltage



Typical Performance

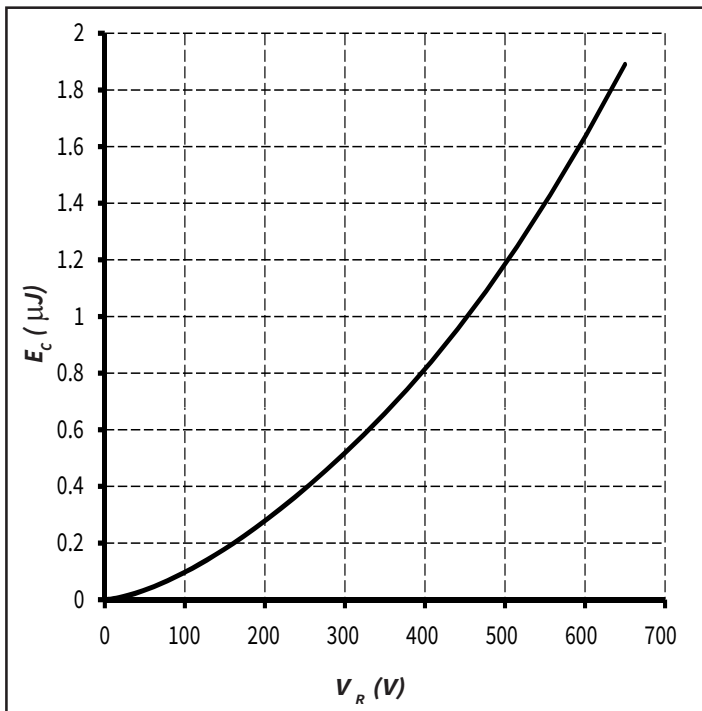

Figure 7. Capacitance Stored Energy

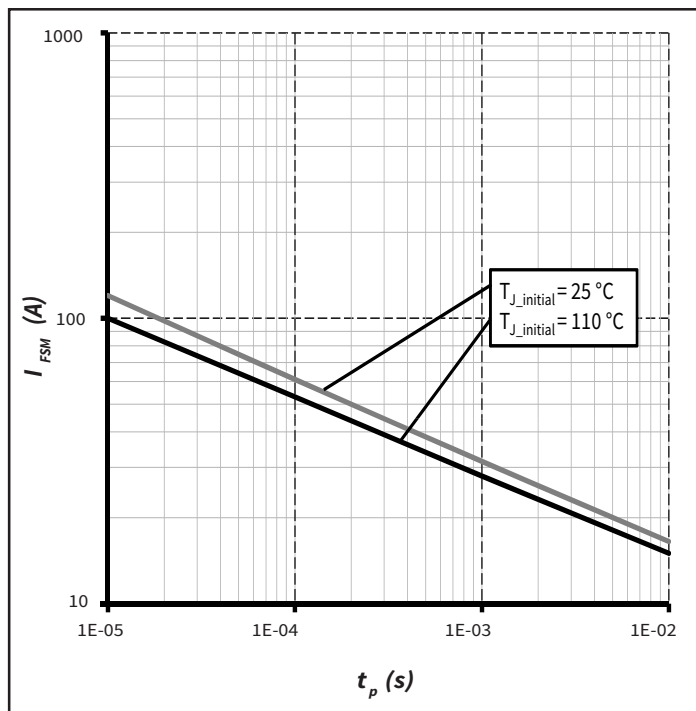

Figure 8. Non-Repetitive Peak Forward Surge Current Versus Pulse Duration (Sinusoidal Waveform)

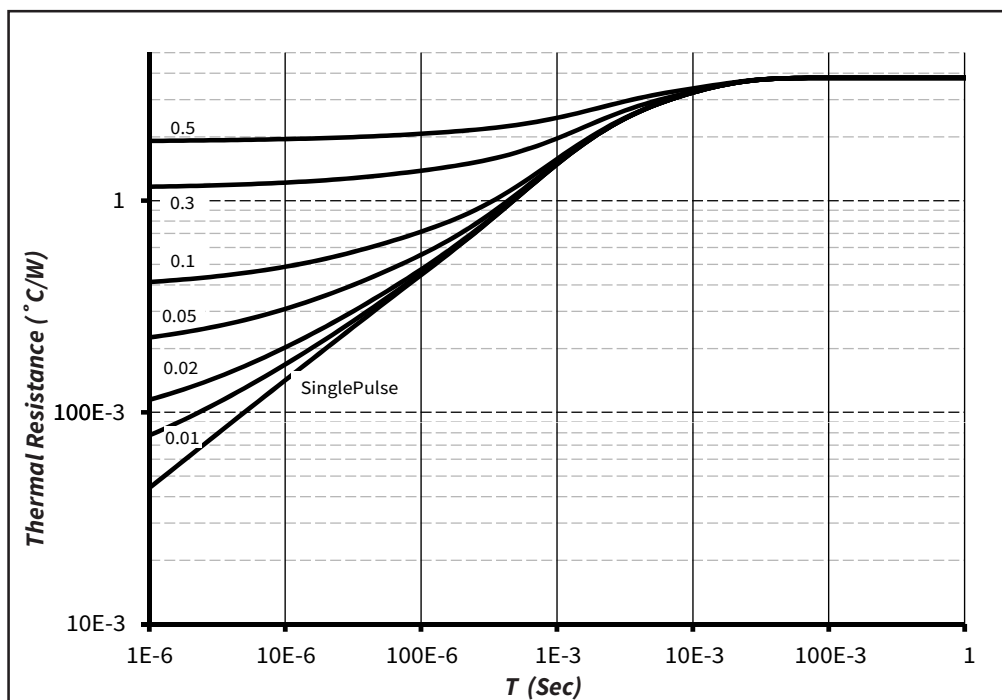
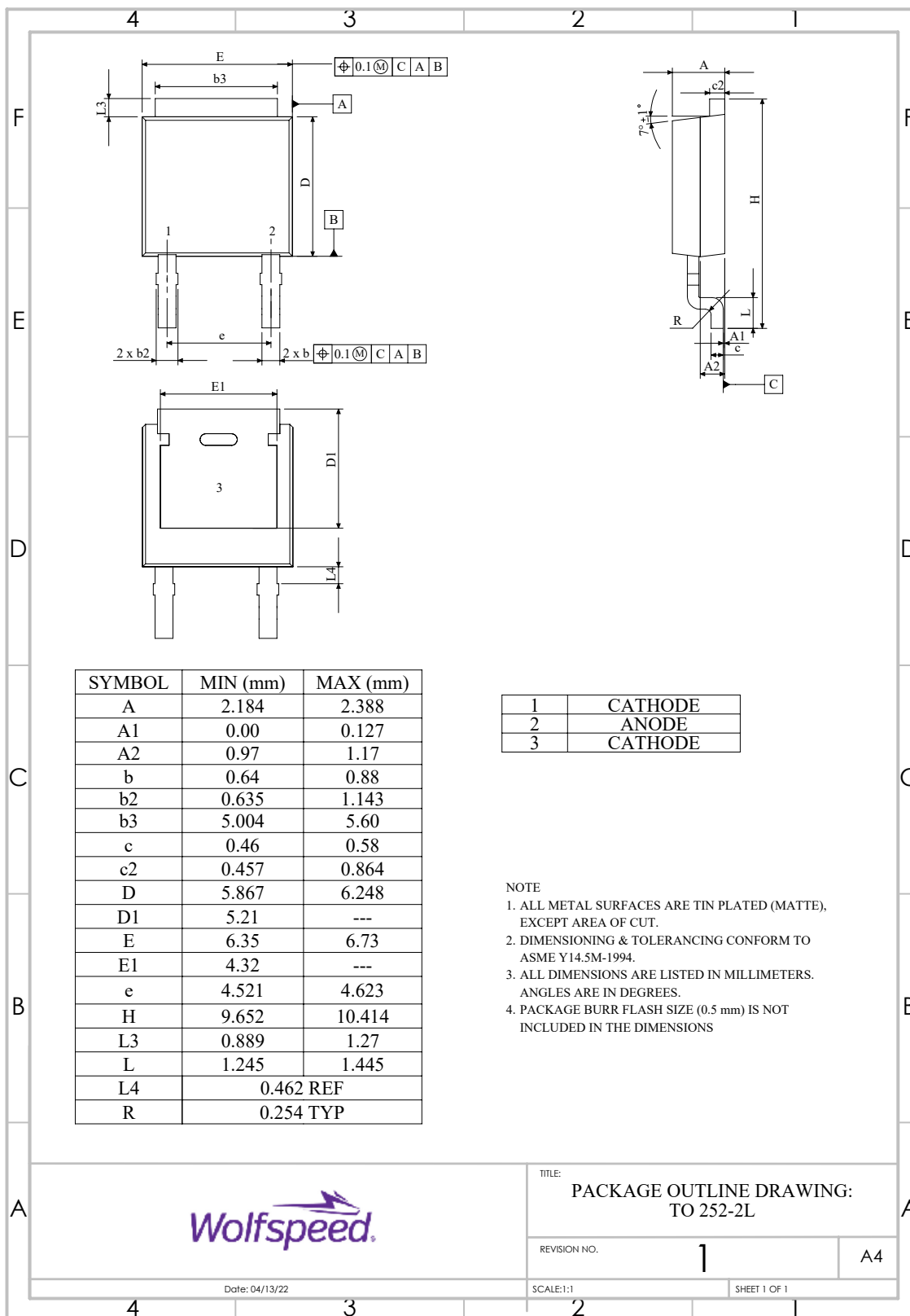

Figure 9. Transient Thermal Impedance



Package Dimensions

Package: TO-252-2



Date: 04/13/22

SCALE:1:1

SHEET 1 OF 1



Recommended Solder Pad Layout

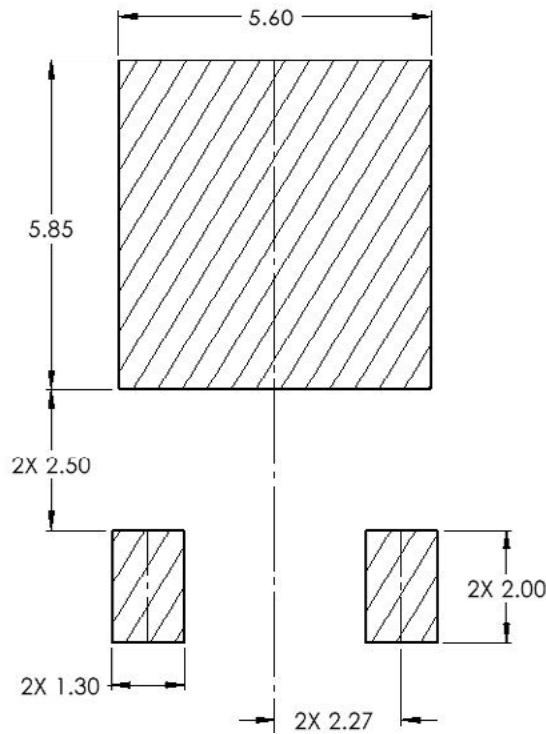

Part Number	Package	Marking
C3D02065E	TO-252-2	C3D02065

Diode Model

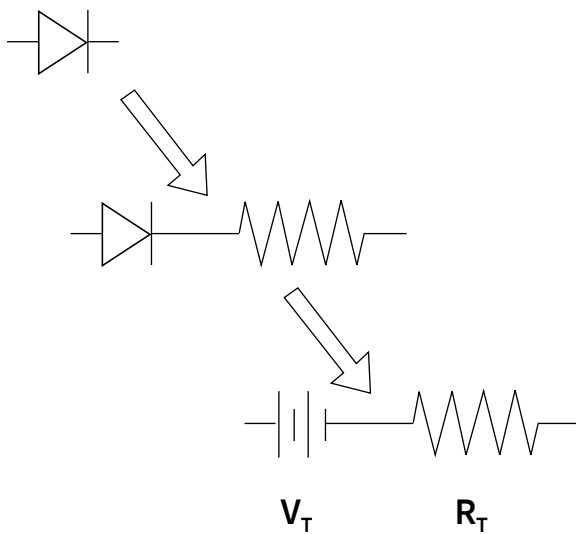

$$V_{fT} = V_T + I_f \cdot R_T$$

$$V_T = 0.98 + (T_j \cdot -1.1 \cdot 10^{-3})$$

$$R_T = 0.18 + (T_j \cdot 1.8 \cdot 10^{-3})$$

Note: T_j = Diode Junction Temperature in Degrees Celsius,
Valid from 25 °C to 175 °C



Revision History

Current Revision	Date of Release	Description of Changes
5	September-2023	Updated Wolfspeed branding, package drawing, and solder pad layout, Removed AEC-Q101 banner
6	October-2023	Corrected solder pad layout
7	November - 2024	Legal Disclaimer



Notes & Disclaimer

WOLFSPPEED PROVIDES TECHNICAL AND RELIABILITY DATA, DESIGN RESOURCES, APPLICATION OR OTHER DESIGN ADVICE, WEB TOOLS, AND OTHER RESOURCES “AS IS” AND WITH ALL FAULTS, AND DISCLAIMS ALL WARRANTIES, EXPRESS AND IMPLIED, WITH RESPECT THERETO, INCLUDING WITHOUT LIMITATION ANY IMPLIED WARRANTIES OF MERCHANTABILITY, SUITABILITY, FITNESS FOR A PARTICULAR PURPOSE, OR NON-INFRINGEMENT OF THIRD-PARTY INTELLECTUAL PROPERTY RIGHTS.

This document and the information contained herein are subject to change without notice. Any such change shall be evidenced by the publication of an updated version of this document by Wolfsppeed. No communication from any employee or agent of Wolfsppeed or any third party shall effect an amendment or modification of this document. No responsibility is assumed by Wolfsppeed for any infringement of patents or other rights of third parties which may result from use of the information contained herein. No license is granted by implication or otherwise under any patent or patent rights of Wolfsppeed.

The information contained in this document (excluding examples, as well as figures or values that are labeled as “typical”) constitutes Wolfsppeed’s sole published specifications for the subject product. “Typical” parameters are the average values expected by Wolfsppeed in large quantities and are provided for informational purposes only. Any examples provided herein have not been produced under conditions intended to replicate any specific end use. Product performance can and does vary due to a number of factors.

This product has not been designed or tested for use in, and is not intended for use in, any application in which failure of the product would reasonably be expected to cause death, personal injury, or property damage. For purposes of (but without limiting) the foregoing, this product is not designed, intended, or authorized for use as a critical component in equipment implanted into the human body, life-support machines, cardiac defibrillators, and similar emergency medical equipment; air traffic control systems; or equipment used in the planning, construction, maintenance, or operation of nuclear facilities. Notwithstanding any application-specific information, guidance, assistance, or support that Wolfsppeed may provide, the buyer of this product is solely responsible for determining the suitability of this product for the buyer’s purposes, including without limitation (1) selecting the appropriate Wolfsppeed products for the buyer’s application, (2) designing, validating, and testing the buyer’s application, and (3) ensuring the buyer’s application meets applicable standards and any other legal, regulatory, and safety-related requirements.

RoHS Compliance

The levels of RoHS restricted materials in this product are below the maximum concentration values (also referred to as the threshold limits) permitted for such substances, or are used in an exempted application, in accordance with EU Directive 2011/65/EC (RoHS2), as implemented January 2, 2013. RoHS Declarations for this product can be obtained from your Wolfsppeed representative or from the Product Documentation sections of www.wolfsppeed.com.

REACH Compliance

REACH substances of high concern (SVHCs) information is available for this product. Since the European Chemical Agency (ECHA) has published notice of their intent to frequently revise the SVHC listing for the foreseeable future, please contact your Wolfsppeed representative to ensure you get the most up-to-date REACH SVHC Declaration. REACH banned substance information (REACH Article 67) is also available upon request.

Contact info:

4600 Silicon Drive
Durham, NC 27703 USA
Tel: +1.919.313.5300
www.wolfsppeed.com/power

© 2024 Wolfsppeed, Inc. All rights reserved. Wolfsppeed® and the Wolfstreak logo are registered trademarks and the Wolfsppeed logo is a trademark of Wolfsppeed, Inc.
PATENT: <https://www.wolfsppeed.com/legal/patents>

The information in this document is subject to change without notice.

Looking for pricing, stock, or lifecycle information?

Click below to explore more details on WIN SOURCE:

 [View C3D02065E on WIN SOURCE](#)

 [Cree/Wolfspeed Information](#)

Optimize Your Supply Chain with WIN SOURCE Solutions

-  Global Sourcing Solution
-  Obsolete Management
-  Cost Control Management
-  Shortage Management
-  Alternative Solution
-  Excess Inventory Management