

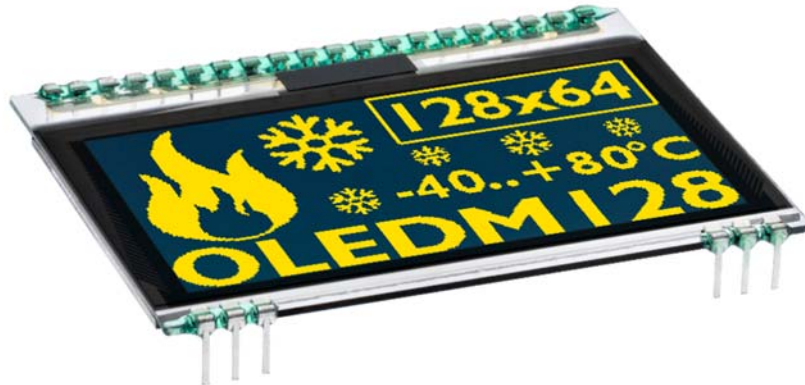

**THE DATASHEET OF
EA OLEDM128-6LGA**



INCL CONTROLLER SSD1306 FOR SPI AND I²C



Dimension 55x46x3.3mm

FEATURES

- 128X64 DOTS (RELATES TO 8x21 CHARACTER OR 4x16 LARGE CHARACTER)
- HIGH CONTRAST OLED DISPLAY
- INTEGRATED CONTROLLER SSD1306
- SPI INTERFACE: MOSI, CLK, CS, D/C
- I²C INTERFACE: SDA, SCL
- WIDE TEMPERATURE RANGE (T_{OP} -40°C - +80°C)
- NO MOUNTING REQUIRED: JUST PUT INTO PCB
- 3 VERSIONS (WITH / W.O. POLARISOR AND PROTECTION GLASS) IN VARIOUS COLORS)
- FAST RESPONSE TIME, NO AFTERGLOW

ORDERING CODES

- GRAPHIC 128x64, yellow, black background, incl. protection glass
- GRAPHIC 128x64, yellow, black background, w./o. protection glass
- GRAPHIC 128x64, white, black background, w./o. protection glass

EA OLEDM128-6GGA
EA OLEDM128-6LGA
EA OLEDM128-6LWA

WITH A MINIMUM ORDER QTY. OF 10,000 PCS.

- GRAPHIC 128x64, with Polariser (Standard)

EA OLEDM128-6LxA

x: E = Green
B = Blue
R = Red

ACCESSORIES

- TEST BOARD WITH USB-INTERFACE
- SOCKET 4.8mm HOCH (2 PCS. ARE REQUIRED)
- TOUCHPANEL, 4-WIRE ANALOGUE SELF-ADHESIVE
- ZIFF CONNECTOR FOR TOUCH, BOTTOM CONTACT

EA 9781-2USB
EA FL-20P
EA TOUCH128-1*)
EA WF100-04S

*) IN COMBINATION WITH EA OLEDM128-6GGA ONLY

EA OLED SERIES

With its EA OLED series DISPLAY VISIONS launched worldwide the first display family with OLED-technology for direct mounting and soldering. In comparison to standard displays there's no FFC/FPC cable/connector that may lose contact, this OLED series will be soldered directly or put into a standard 2.54 mm precision socket.

It is designed for compact handheld equipment and provides a lot real advantages:

- Extreme compact (55x46mm) with a large viewing area (51x31mm)
- Super flat with 2.1 mm (without frontal protection glass)
- SPI and I²C interface
- Simple mounting with direct soldering
- Ex stock available from 1 pc. off
- Long life time (up to 100,000 h are possible)
- Wide temperature range (-40..+80°C)
- Fast response time (10µs), no afterglow

VERSIONS

The EA OLEDM128-6 is available in 3 different versions:

EA OLEDM128-6GGA / Allround

This module is perfect for rough environment. An additional frontal glass protects the display against scratch, shock and UV light. Thanks to its integrated polariser there's no need for an additionally smoked glass.

EA OLEDM128-6LGA and -6LWA / Flat

This module is the standard module and does fit for the most applications. The flat design (2.4 mm) makes the display perfect for smallest equipment. The background is always deep black for best contrast.

COLORS (CUSTOM MADE)

The standard colors are yellow and white.

The flat version EA OLEDM128-6LGA is on customers request available in 3 more colors. The minimum order quantity is 10,000 pcs. and lead time is about 20 weeks. Samples are available on request.

Interface and software are 100% compatible. The yellow color provides highest brightness and longest life time.



EA OLEDM128-6LEA



EA OLEDM128-6LRA



EA OLEDM128-6LBA

DATA TRANSFER 4-WIRE SPI (8 BIT)

Data transmission for SPI is unidirectional, that means that data can only be written, there's no data read option. Selection for writing data or command is done with the D/C line. A busy check is not necessary at all. Clock rate may be up to 10 MHz. Data transmission is based on SPI mode 3, MSB first. For more details please refer to the controllers data sheet SSD1306.

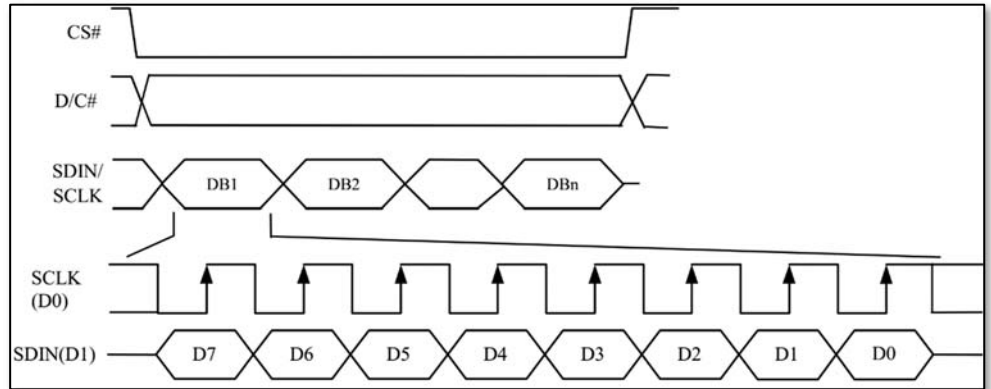

DATA TRANSFER 4-WIRE SPI (9 BIT)

Data transmission for SPI is unidirectional, that means that data can only be written, there's no data read option. Selection for writing data or command is done with the first bit of the 9 bit data transfer. A busy check is not necessary at all. Clock rate may be up to 10 MHz. Data transmission is based on SPI mode 3, MSB first (9 bit). For more details please refer to the controllers data sheet SSD1306.

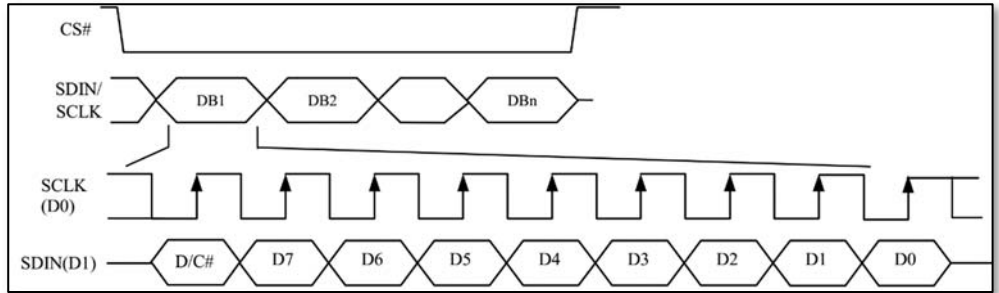

DATA TRANSFER I²C

The I²C mode provides a bi-directional data transmission: That means that data can be written and read. With the pin SA0 the I²C address can be changed, so up to 2 displays may be driven on 1 bus. The clock rate may be up to 400 KHz. Please make sure when defining the pull-up resistors that the internal resistance of the display is 600..1000 Ω. This affects the low level when reading data and ACK bit.

Attention: When reading data, after the command for page- or column address there need to be a dummy read (discard the first byte).

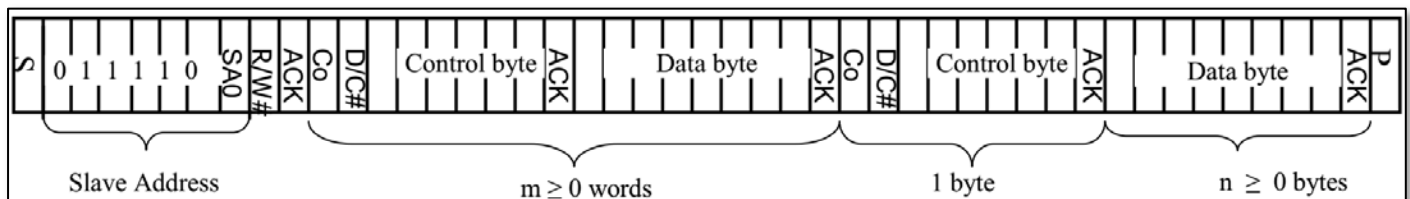

Control byte: C₀ (Continuation bit) = 0 → Display data do follow; 1 → refer D/C bit

GRAPHIC RAM

The EA OLEDM128-6 comes with an integrated display RAM. Each byte represents 8 dots. For more details please refer to the controllers data sheet SSD1306, available on our website at http://www.lcd-module.de/fileadmin/eng/pdf/zubehoer/SSD1306B_1.1.pdf.

Column address		0	127
D0	D7	Page 0	
D0	D7	Page 1	
D0	D7	Page 2	
D0	D7	Page 3	
D0	D7	Page 4	
D0	D7	Page 5	
D0	D7	Page 6	
D0	D7	Page 7	

COMMAND TABLE (ABSTRACT)

This is a collection of the most important commands. The data sheet SSD1306 provides the full list plus a detailed description.

Command	D/ C	Command Code									Description
		Hex	D7	D6	D5	D4	D3	D2	D1	D0	
Contrast Control	0 0	81 7F	1 A ₇	0 A ₆	0 A ₅	0 A ₄	0 A ₃	0 A ₂	0 A ₁	1 A ₀	Double byte command to select 1 out of 256 contrast steps. Contrast increases as the value increases.
Display On / Off	0	AE/ AF	1	0	1	0	1	1	1	X ₀	X ₀ =0: Display OFF (sleep mode) (RESET) X ₀ =1: Display ON in normal mode
Set Column address	0 0 0	21 0 7F	0 A ₇ B ₇	0 A ₆ B ₆	1 A ₅ B ₅	0 A ₄ B ₄	0 A ₃ B ₃	0 A ₂ B ₂	0 A ₁ B ₁	1 A ₀ B ₀	Setup column start and end address A[7:0] : Column start address, range : 0-127d, (RESET = 0) B[7:0]: Column end address, range : 0-127d, RESET = 127) Note: This command is only for horizontal or vertical addressing mode.
Set Page address	0 0 0	22 0 7	0 X X	0 X X	1 X X	0 X X	0 X X	0 A ₂ B ₂	1 A ₁ B ₁	0 A ₀ B ₀	Setup page start and end address A[2:0] : Page start Address, range : 0-7d, (RESET = 0) B[2:0] : Page end Address, range : 0-7d, (RESET = 7) Note: This command is only for horizontal or vertical addressing mode.
Display Start Line	0	40 - 7F	0	1	A ₅	A ₄	A ₃	A ₂	A ₁	A ₀	Set display RAM display start line register from 0-63 using X ₅ X ₃ X ₂ X ₁ X ₀ . Display start line register is reset to 0 during RESET.
Segment remap	0	A0/ A1	1	0	1	0	0	0	0	X ₀	X ₀ =0: column address 0 is mapped to SEG0 (RESET) X ₀ =1: column address 127 is mapped to SEG0
Com output scan direction	0	C0/ C8	1	1	0	0	X ₃	0	0	0	X ₃ =0: normal mode (RESET) Scan from COM0 to COM[N-1] X ₃ =1: remapped mode. Scan from COM[N-1] to COM0 Where N is the Multiplex ratio
RAM Data	1	XX	D ₇	D ₆	D ₅	D ₄	D ₃	D ₂	D ₁	D ₀	D ₇ -D ₀ is written to RAM.

INITIALISATION EXAMPLE

```
void init_OLEDM128(void)
{
    send_command(0x40);           //Set Display start line
    send_command(0xA0);           //Bottom View no Segment remap
    send_command(0xC0);           //Bottom View COM scan direction normal
    send_command(0xA6);           //Display normal (RAM)
    send_command(0x81); send_command(0xFF); //Set contrast to maximum
    send_command(0xD5); send_command(0x40); //Clock divider/Oscillator frequency
    send_command(0xD9); send_command(0x44); //Pre-charge Period
    send_command(0xAF);           //Display on
}
```

ACCESSORY: SOCKET EA FL-20P

Using a 20-pin socket makes the display replaceable and adapts the height. Those socket may also be soldered automatically by wave soldering or reflow process. Each display requires 2 pcs. Also available in SMT (EA FL-20PS).

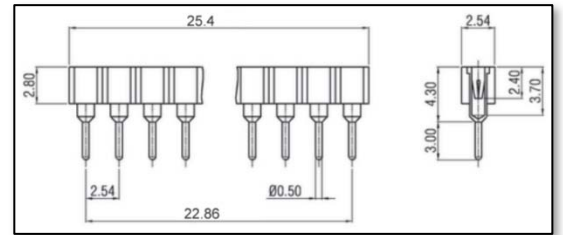

ACCESSORY: TOUCHPANEL EA TOUCH128-1

As an accessory there is an analogue touchpanel available. It comes with a self-adhesive glue on its rear side. Connection is done via FFC, pitch 1.0 mm. Any standard ZIFF connector can be used (e.g. EA WF100-04S). Bending radius is minimum 5 mm. Interfacing to a processor can be either done by an external touch panel controller or with a controller that is featured with analogue input. The touch panel is similar to a potentiometer: connecting a voltage of e.g. 3.3 V to the pins Top-Bottom makes it possible to read out a voltage on pin Left or Right which is linear to the Y-coordinate of the pressed point. The X-coordinate will result when the voltage will be supplied to Left-Right and measurement is done at Top or Bottom. The pinout of the connecting cable is shown in the drawing. Only in combination with the EA OLEDM128-6GGA.

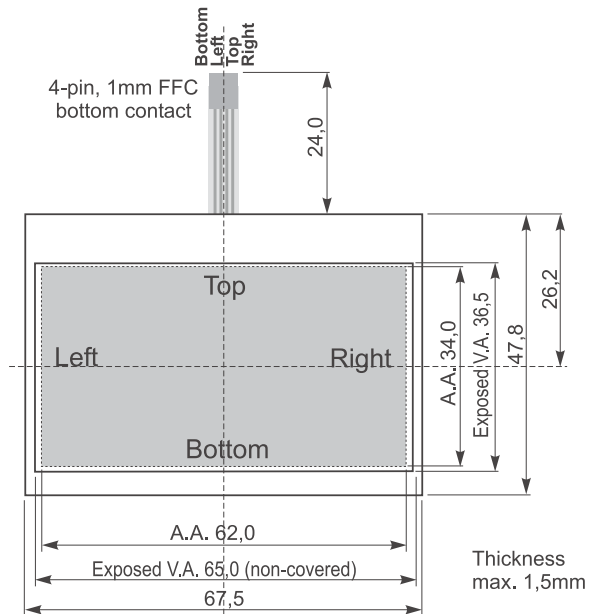

Specification			
Value	min	max	Unit
Top-Bottom	120	300	Ω
Left-Right	580	900	Ω
Voltage	3	12	V
Current	5	25	mA
Linearity	1,5		%
Force	45	65	G
Contact Bounce	5	10	Ms
T _{op.}	-20	+60	°C
T _{Stor.}	-20	+70	°C
Transmission	75	85	%
Lifetime	10000		Cycles

ACCESSORY: ZIFF CONNECTOR EA WF100-04S

The ZIFF connector matches perfect to the touch panel EA TOUCH128-1. It provides 4 pins with 1.0 mm pitch. Connection is bottom contact. The top contact version is called EA WF100-04T.

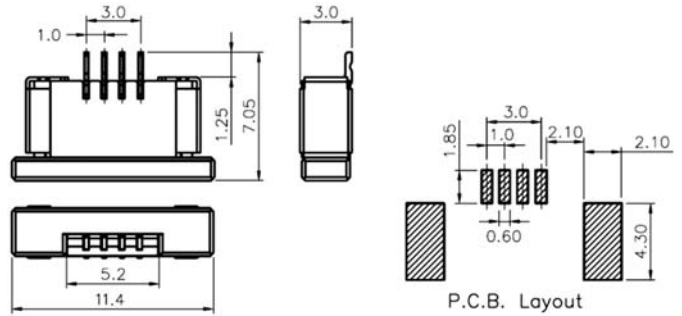

USB-TEST BOARD EA 9781-2USB

For easy startup, a USB test board is available that can be connected to a PC. A USB cable and Windows software is supplied with the product. It allows text and images (BMP) to displayed directly on the connected display. The board provides many connectors matching different OLED displays from DISPLAY VISIONS. You will find more information on the test board in the data sheet [EA 9781-2USB](#).



SIMULATION WITH WINDOWS

A little software tool called "OLED Simulator" shows the OLED display with individual content. It also drives the USB test board with the real display to show same content. You can download the software free from our website. Note that all functions of the simulation software do run also without the USB board. https://www.lcd-module.de/fileadmin/downloads/startoled_v20.zip

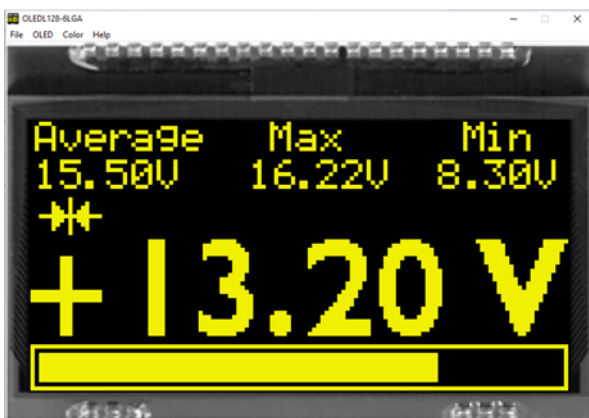

SPECIFICATION

Unless otherwise specified, VSS = 0V , VDD = 1.8 - 3.3V (Ta = 25°C)

Value	Condition	min	typ	max	Unit
Operating Temperature		-40		+80	°C
Storage Temperature		-40		+80	°C
Storage Humidity	<40°C			90	%RH
Operating Voltage VDD logic supply		1.8	3.0	3.3	V
Operating Voltage VCC OLED supply			12.5	13.0	V
High Logic input level		0.8 x VDD			
Low Logic input level				0.2 x VDD	V
Power Supply VCC ¹⁾	All Pixel off		0,4		mA
	Demo picture ²⁾		12		mA
	All Pixel on		28		mA

¹⁾ VCC= 12V, initialization 0x81,0xFF / 0xD5,0x40 / 0xD9,0x44 / 0xDB,0x20

²⁾ Demo Picture:



OPTICAL DATA

Item	Symbol	Condition	min	typ	max	Unit
View Angle	(V)θ	CR≥2000	160	170		deg
	(H)φ	CR≥2000	160	170		deg
Contrast Ratio	CR	Dark Room	2000:1			
Response Time	T rise			10		µs
	T fall			10		µs
Luminance ¹⁾	L	-6GGA / -6LGA	90	100		cd/m ²
CIE 1931 x(Yellow)		Dark Room	0.45	0.47	0.49	
CIE 1931 y(Yellow)		Dark Room	0.48	0.50	0.52	
Operating Life Time ²⁾	yellow	50% chess board	50,000			hrs
	white		20,000			

¹⁾ VDD= 3.3V, incl. booster ¹⁾ VDD= 3.3V, incl. booster FAN5331 with VCC= 12.5V

²⁾ Ta=25°C, operating life time is defined the amount of time until the luminance has decayed to 50% of the initial value. Screen saving mode is recommended to extend life time

DIMENSIONS EA OLEDM128-6

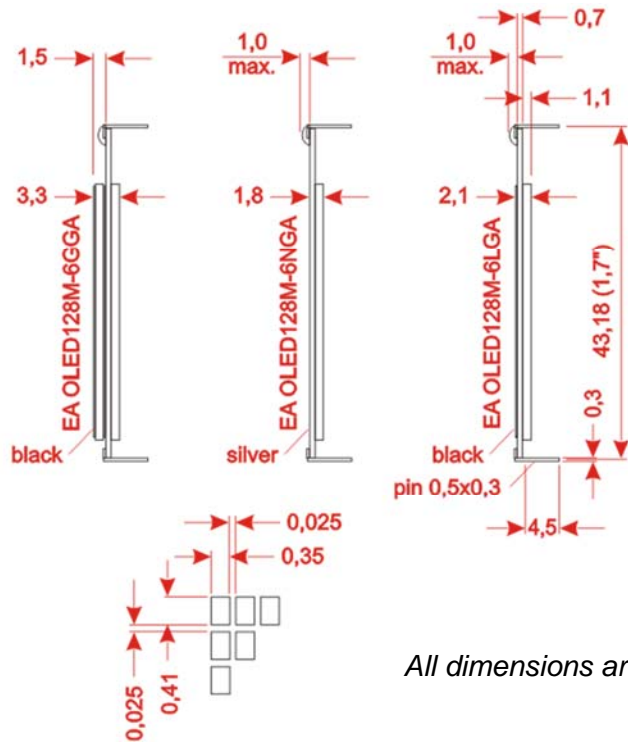
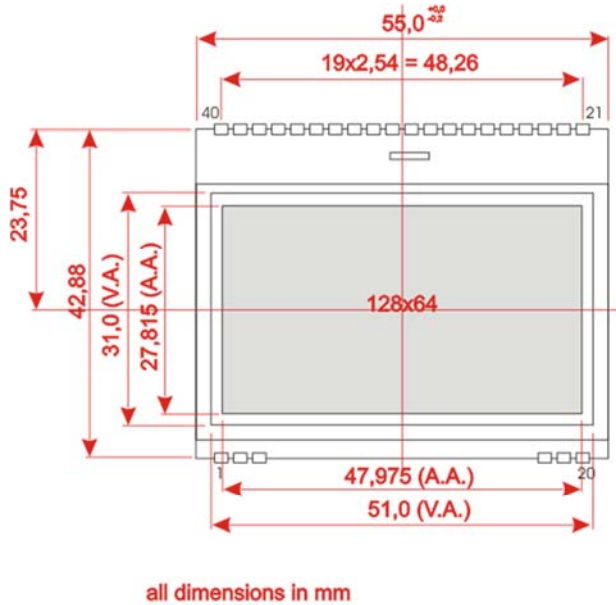

Pin	Symbol	Pin	Symbol	Description
1	ESD_GND	21	VCC	Typ. 12 V OLED driving voltage
2	NC	22	VCC	
3	NC	23	GND	Ground
4		24	GND	
5		25	VDD	Typ. 3.3 V logic power supply
6		26	BS0	00 = 4-Wire SPI; 01 = 3-Wire SPI
7		27	BS1	10 = I ² C Interface
8		28	GND	Ground
9		29	CS	Chip Select (active low)
10		30	RES	Reset (active low)
11		31	D/C	SPI (4-Wire): L=Command, H=Data, I ² C: SA0
12		32	D0	SPI: SCLK, I ² C: SCL
13		33	D1	SPI: MOSI, I ² C: SDA _{in}
14		34	D2	SPI: NC, I ² C: SDA _{out}
15		35	GND	Ground
16		36	Iref	Reference for current source for segment drivers
17		37	VCOMH	Common deselect level. (Internally regulated)
18	NC	38	VCOMH	
19	NC	39	VCC	Typ. 12 V OLED driving voltage
20	ESD_GND	40	VCC	

Note:
 - OLED displays are generally not suited for wave or reflow soldering. Temperatures of over 80°C can cause lasting damage.
 - The surfaces of the displays are protected from scratching by self-adhesive protective foil. Please remove before mounting



Looking for pricing, stock, or lifecycle information?

Click below to explore more details on WIN SOURCE:

- ⊖ [View EA OLEDM128-6LGA on WIN SOURCE](#)
- ⊖ [Display Visions Information](#)

Optimize Your Supply Chain with WIN SOURCE Solutions

- ✓ Global Sourcing Solution
- ✓ Obsolete Management
- ✓ Cost Control Management
- ✓ Shortage Management
- ✓ Alternative Solution
- ✓ Excess Inventory Management