



**THE DATASHEET OF  
FTL410QE2C**



## Product Specification

### 40BASE-SR4 100m QSFP+ Gen2 Optical Transceiver Module FTL410QE2C

#### PRODUCT FEATURES

- Four-channel full-duplex transceiver module
- Hot Pluggable QSFP+ form factor
- Maximum link length of 100m on OM3 Multimode Fiber (MMF) and 150m on OM4 MMF
- Multirate capability: 1.06Gb/s to 10.5Gb/s per channel
- Unretimed XLPI electrical interface
- Maximum power dissipation <1.5W
- Reliable VCSEL array technology
- Built-in digital diagnostic functions
- Commercial operating case temperature range: 0°C to 70°C
- Single 1x12 MPO receptacle
- RoHS-6 Compliant (lead-free)



#### APPLICATIONS

- 40GBASE-SR4 40G Ethernet
- Breakout to 10GBASE-SR Ethernet
- Proprietary interconnections

Finisar's FTL410QE2C QSFP+ transceiver modules are designed for use in 40 Gigabit per second links over multimode fiber. They are compliant with the QSFP+ MSA<sup>1,2</sup> and IEEE 802.3ba 40GBASE-SR4<sup>3</sup>. Digital diagnostics functions are available via an I2C interface, as specified by the QSFP+ MSA. The transceiver is RoHS-6 compliant and lead-free per Directive 2002/95/EC, and Finisar Application Note AN-2038<sup>5</sup>.

#### PRODUCT SELECTION

**FTL410QE2C**

**I. Pin Descriptions**

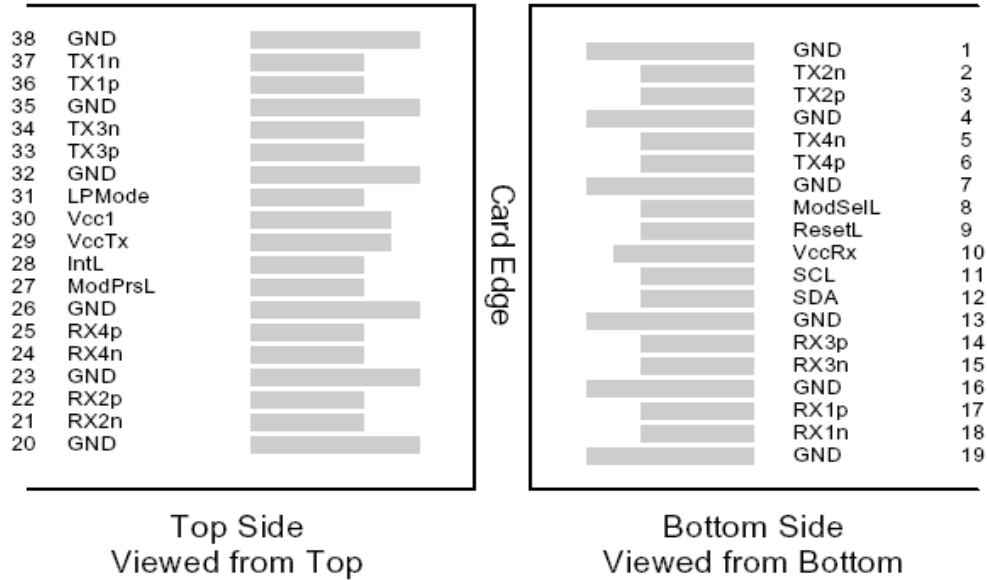

**Figure 1 – QSFP+ MSA-compliant 38-pin connector**

Pin	Symbol	Name/Description	Notes
1	GND	Ground	1
2	Tx2n	Transmitter Inverted Data Input	
3	Tx2p	Transmitter Non-Inverted Data Input	
4	GND	Ground	1
5	Tx4n	Transmitter Inverted Data Input	
6	Tx4p	Transmitter Non-Inverted Data Input	
7	GND	Ground	1
8	ModSelL	Module Select	
9	ResetL	Module Reset	
10	Vcc Rx	+3.3 V Power supply receiver	
11	SCL	2-wire serial interface clock	
12	SDA	2-wire serial interface data	
13	GND	Ground	1
14	Rx3p	Receiver Non-Inverted Data Output	
15	Rx3n	Receiver Inverted Data Output	
16	GND	Ground	1
17	Rx1p	Receiver Non-Inverted Data Output	
18	Rx1n	Receiver Inverted Data Output	
19	GND	Ground	1
20	GND	Ground	1
21	Rx2n	Receiver Inverted Data Output	
22	Rx2p	Receiver Non-Inverted Data Output	
23	GND	Ground	1
24	Rx4n	Receiver Inverted Data Output	

25	Rx4p	Receiver Non-Inverted Data Output	
26	GND	Ground	1
27	ModPrsL	Module Present	
28	IntL	Interrupt	
29	Vcc Tx	+3.3 V Power supply transmitter	
30	Vcc1	+3.3 V Power Supply	
31	LPMode	Low Power Mode	
32	GND	Ground	1
33	Tx3p	Transmitter Non-Inverted Data Input	
34	Tx3n	Transmitter Inverted Data Input	
35	GND	Ground	1
36	Tx1p	Transmitter Non-Inverted Data Input	
37	Tx1n	Transmitter Inverted Data Input	
38	GND	Ground	1

Notes

1. Circuit ground is internally isolated from chassis ground.

**II. General Product Characteristics**

Parameter	Value	Unit	Notes
Module Form Factor	QSFP+		
Number of Lanes	4 Tx and 4 Rx		
Maximum Aggregate Data Rate	42.0	Gb/s	
Maximum Data Rate per Lane	10.5	Gb/s	Higher bit rates may be supported. Please contact Finisar.
Protocols Supported	Typical applications include 40G Ethernet, Infiniband, Fibre Channel, SATA/SAS3		
Electrical Interface and Pin-out	38-pin edge connector		Pin-out as defined by the QSFP+ MSA
Maximum Power Consumption per End	1.5	Watts	Varies with output voltage swing and pre-emphasis settings (see Figure 2)
Management Interface	Serial, I2C-based, 400 kHz maximum frequency		As defined by the QSFP+ MSA

Data Rate Specifications	Symbol	Min	Typ	Max	Units	Ref.
Bit Rate per Lane	BR	1062		10500	Mb/sec	1
Bit Error Ratio	BER			$10^{-12}$		2
Link distance on OM3 MMF	d			100	meters	3
Link distance on OM4 MMF	d			150	meters	3

Notes:

1. Compliant with 40G Ethernet. Compatible with 1/10 Gigabit Ethernet and 1/2/4/8/10G Fibre Channel.
2. Tested with a PRBS  $2^{31}-1$  test pattern.
3. Per 40GBASE-SR4, IEEE 802.3ba

**III. Absolute Maximum Ratings**

Parameter	Symbol	Min	Typ	Max	Unit	Ref.
Maximum Supply Voltage	V <sub>cc1</sub> , V <sub>ccTx</sub> , V <sub>ccRx</sub>	-0.5		3.6	V	
Storage Temperature	T <sub>S</sub>	-40		85	°C	
Case Operating Temperature	T <sub>OP</sub>	0		70	°C	
Relative Humidity	RH	0		85	%	1
Damage Threshold, per Lane	DT	3.4			dBm	

## Notes:

1. Non-condensing.

**IV. Electrical Characteristics (T<sub>OP</sub> = 0 to 70°C, V<sub>CC</sub> = 3.15 to 3.45 Volts)**

Parameter	Symbol	Min	Typ	Max	Unit	Ref.
Supply Voltage	V <sub>cc1</sub> , V <sub>ccTx</sub> , V <sub>ccRx</sub>	3.15		3.45	V	
Supply Current	I <sub>cc</sub>			350	mA	
<b>Link turn-on time</b>						
Transmit turn-on time				2000	ms	2
<b>Transmitter (per Lane)</b>						
Single ended input voltage tolerance	V <sub>inT</sub>	-0.3		4.0	V	
Differential data input swing	V <sub>in,pp</sub>	180		1200	mV <sub>pp</sub>	3
Differential input threshold			50		mV	
AC common mode input voltage tolerance (RMS)		15			mV	
Differential input return loss		Per IEEE P802.3ba, Section 86A.4.1.1			dB	4
J2 Jitter Tolerance	J <sub>t2</sub>	0.17			UI	
J9 Jitter Tolerance	J <sub>t9</sub>	0.29			UI	
Data Dependent Pulse Width Shrinkage	DDPWS	0.07			UI	
Eye mask coordinates {X1, X2 Y1, Y2}		0.11, 0.31 95, 350			UI mV	5
<b>Receiver (per Lane)</b>						
Single-ended output voltage		-0.3		4.0	V	
Differential data output swing	V <sub>out,pp</sub>	0		800	mV <sub>pp</sub>	7,8
AC common mode output voltage (RMS)				7.5	mV	
Termination mismatch at 1 MHz				5	%	
Differential output return loss		Per IEEE P802.3ba, Section 86A.4.2.1			dB	4
Common mode output return loss		Per IEEE P802.3ba, Section 86A.4.2.2			dB	4
Output transition time, 20% to 80%		28			ps	
J2 Jitter output	J <sub>o2</sub>			0.42	UI	
J9 Jitter output	J <sub>o9</sub>			0.65	UI	
Eye mask coordinates #1 {X1, X2 Y1, Y2}		0.29, 0.5 150, 425			UI mV	6

Eye mask coordinates #2 {X1, X2 Y1, Y2}		0.29, 0.5 125, 500	UI mV	5
Power Supply Ripple Tolerance	PSR	50	mVpp	

Notes:

1. Maximum total power value is specified across the full temperature and voltage range.
2. From power-on and end of any fault conditions.
3. After internal AC coupling. Self-biasing 100Ω differential input.
4. 10 MHz to 11.1 GHz range
5. Hit ratio =  $5 \times 10E-5$ . Valid for all settings in Figure 2.
6. Hit ratio =  $5 \times 10E-5$ . Valid only for the shaded settings in Figure 2.
7. AC coupled with 100Ω differential output impedance.
8. Settable in 4 discrete steps via the I2C interface. See Figure 2 for Vout settings.

Power (mW)		Pre-Emphasis into 100ohms (mV)			
		0	125	175	325
Vout (mV)	0	599			
	317	751	935	971	1075
	422	787	971	1007	1111
	739	883	1055	1103	1190

Figure 2 – Power Dissipation (mW, maximum) vs. Rx Output Conditions

**V. Optical Characteristics (T<sub>OP</sub> = 0 to 70°C, V<sub>CC</sub> = 3.15 to 3.45 Volts)**

Parameter	Symbol	Min	Typ	Max	Unit	Ref.
<b>Transmitter (per Lane)</b>						
Signaling Speed per Lane			10.5		GBd	1
Center wavelength		840		860	nm	
RMS Spectral Width	SW			0.65	nm	
Average Launch Power per Lane	TXP <sub>x</sub>	-7.6		-1.0	dBm	
Transmit OMA per Lane	TxOMA	-5.6		3.0	dBm	2
Difference in Power between any two lanes [OMA]	DP <sub>x</sub>			4.0	dB	
Peak Power per Lane	PP <sub>x</sub>			4.0	dBm	
Launch Power [OMA] minus TDP per Lane	P-TDP	-6.5			dBm	
TDP per Lane	TDP			3.5	dBm	
Optical Extinction Ratio	ER	3.0			dB	
Optical Return Loss Tolerance	ORL			12	dB	
Encircled Flux	FLX	> 86% at 19 um < 30% at 4.5 um			dBm	
Average launch power of OFF transmitter, per lane				-30	dBm	
Relative Intensity Noise	RIN			-128	dB/Hz	
Transmitter eye mask definition {X1, X2, X3, Y1, Y2, Y3}		0.23, 0.34, 0.43, 0.27, 0.35, 0.4				

Parameter	Symbol	Min	Typ	Max	Unit	Ref.
<b>Receiver (per Lane)</b>						
Signaling Speed per Lane			10.5		GBd	3
Center wavelength		840		860	nm	
Damage Threshold	DT	3.4			dBm	
Average Receive Power per Lane	RXP <sub>x</sub>	-9.5		2.4	dBm	
Receive Power (OMA) per Lane	RxOMA			3.0	dBm	
Stressed Receiver Sensitivity (OMA) per Lane	SRS			-5.4	dBm	
Peak Power, per lane	PP <sub>x</sub>			4	dBm	
Receiver Reflectance	Rfl			-12	dB	
Vertical eye closure penalty, per lane				1.9	dB	
Stressed eye J2 jitter, per Lane				0.3	UI	
Stressed eye J9 jitter, per Lane				0.47	UI	
OMA of each aggressor lane				-0.4	dBm	
Rx jitter tolerance: Jitter frequency and p-p amplitude		(75, 5)			kHz, UI	
		(375, 1)			kHz, UI	
LOS De-Assert	LOS <sub>D</sub>			-12	dBm	
LOS Assert	LOS <sub>A</sub>	-30			dBm	
LOS Hysteresis		0.5			dBm	

**Notes:**

1. Transmitter consists of 4 lasers operating at a maximum rate of 10.5Gb/s each.
2. Even if TDP is <0.9dB, the OMA min must exceed this value.
3. Receiver consists of 4 photodetectors operating at a maximum rate of 10.5Gb/s each.

**VI. Memory Map and Control Registers**

Compatible with SFF-8436 (QSFP+). Please see Finisar Application Note.

**VII. Environmental Specifications**

Finisar FTL410QE2C transceivers have an operating temperature range from 0°C to +70°C case temperature.

Environmental Specifications	Symbol	Min	Typ	Max	Units	Ref.
Case Operating Temperature	T <sub>op</sub>	0		70	°C	
Storage Temperature	T <sub>sto</sub>	-40		85	°C	

### VIII. Regulatory Compliance

Finisar FTL410QE2C transceivers are RoHS-6 Compliant. Copies of certificates are available at Finisar Corporation upon request.

FTL410QE2C transceiver modules are Class 1 laser eye safety compliant per IEC 60825-1.

### IX. Mechanical Specifications

The FTL410QE2C mechanical specifications are compliant to the QSFP+ MSA transceiver module specifications.

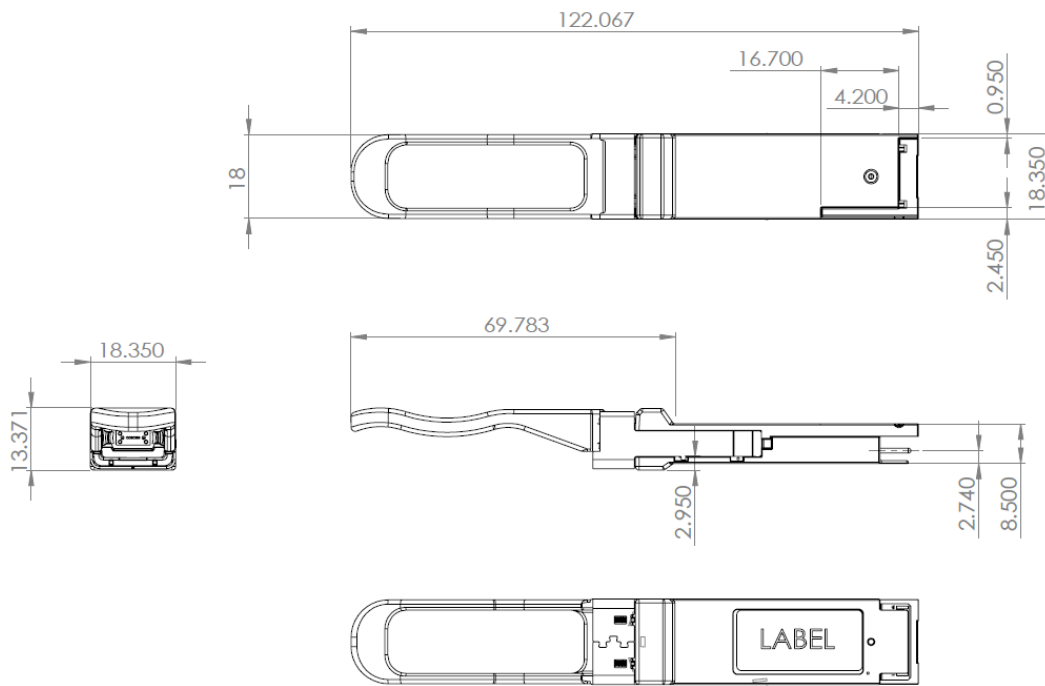

**Figure 3 – FTL410QE2C mechanical drawing**

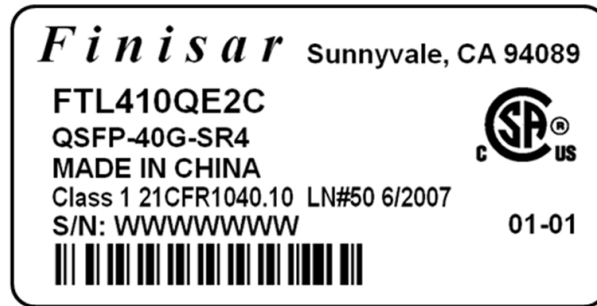

Figure 4 – FTL410QE2C product label

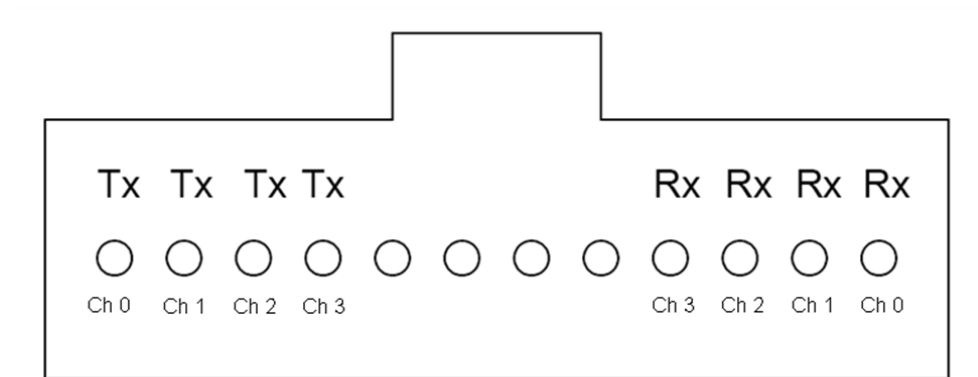

Figure 5 – FTL410QE2C optical lane assignment  
(front view of MPO receptacle)

**X. References**

1. INF-8438i – Specification for QSFP (Quad Small Formfactor Pluggable) Transceiver, Rev 1.0, November 2006
2. SFF-8436 – Specification for QSFP+ Copper and Optical Transceiver, Rev 4.1, August 2011
3. IEEE 802.3ba – PMD Type 40GBASE-SR4.
4. Directive 2002/95/EC of the European Council Parliament and of the Council, “on the restriction of the use of certain hazardous substances in electrical and electronic equipment”. January 27, 2003.
5. “Application Note AN-2038: Finisar Implementation of RoHS Compliant Transceivers”, Finisar Corporation, January 21, 2005.

**XI. For More Information**

Finisar Corporation  
1389 Moffett Park Drive  
Sunnyvale, CA 94089-1133  
Tel. 1-408-548-1000  
Fax 1-408-541-6138  
[sales@finisar.com](mailto:sales@finisar.com)  
[www.finisar.com](http://www.finisar.com)

## Looking for pricing, stock, or lifecycle information?

Click below to explore more details on WIN SOURCE:

 [View FTL410QE2C on WIN SOURCE](#)

 [Coherent Information](#)

## Optimize Your Supply Chain with WIN SOURCE Solutions

-  Global Sourcing Solution
-  Obsolete Management
-  Cost Control Management
-  Shortage Management
-  Alternative Solution
-  Excess Inventory Management