



**THE DATASHEET OF
ADG904SCPZ-EP**





FEATURES

- Wideband switch: -3 dB frequency at 2.5 GHz
- Absorptive 4:1 mux/single-pole, four-throw (SP4T)
- High off isolation (37 dB at 1 GHz)
- Low insertion loss (1.1 dB dc to 1 GHz)
- Single 1.65 V to 2.75 V power supply (V_{DD})
- CMOS/LVTTL control logic
- 20-lead, 4 mm x 4 mm LFCSP package
- Low power consumption (2.5 μ A maximum)

ENHANCED PRODUCT FEATURES

- Supports defense and aerospace applications (AQEC standard)
- Military temperature range: -55°C to +125°C
- Controlled manufacturing baseline
- 1 assembly/test site
- 1 fabrication site
- Enhanced product change notification
- Qualification data available on request

APPLICATIONS

- Wireless communications
- General-purpose radio frequency (RF) switching
- Dual-band applications
- High speed filter selection
- Digital transceiver front-end switches
- IF switching
- Tuner modules
- Antenna diversity switching

GENERAL DESCRIPTION

The [ADG904-EP](#) is a wideband analog 4:1 multiplexer that uses a CMOS process to provide high isolation and low insertion loss to 1 GHz. The [ADG904-EP](#) is an absorptive/matched mux with 50 Ω terminated shunt legs. This device is designed such that the isolation is high over the dc to 1 GHz frequency range.

The [ADG904-EP](#) switches one of four inputs to a common output, RFC, as determined by the 3-bit binary address lines A0, A1, and \overline{EN} . A Logic 1 on the \overline{EN} pin disables the device.

FUNCTIONAL BLOCK DIAGRAM

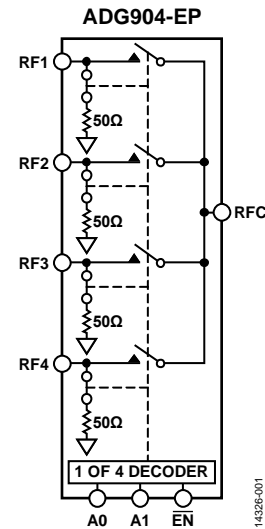

Figure 1.

The device has on-board CMOS control logic, which eliminates the need for external control circuitry. The control inputs are both CMOS and LVTTL compatible. The low power consumption of this device makes it ideally suited for wireless applications and general-purpose high frequency switching.

Additional application and technical information can be found in the [ADG904](#) data sheet.

PRODUCT HIGHLIGHTS

- 37 dB off isolation at 1 GHz.
- 1.1 dB insertion loss at 1 GHz.
- 20-lead LFCSP package.

TABLE OF CONTENTS

Features	1	Absolute Maximum Ratings	5
Enhanced Product Features	1	Thermal Resistance	5
Applications	1	ESD Caution	5
Functional Block Diagram	1	Pin Configuration and Function Descriptions	6
General Description	1	Typical Performance Characteristics	7
Product Highlights	1	Test Circuits	9
Revision History	2	Outline Dimensions	11
Specifications	3	Ordering Guide	11
Continuous Current Per Channel	4		

REVISION HISTORY

5/2017—Rev. B to Rev. C

Change to Endnote 1, Table 3	3
Updated Outline Dimensions	11

3/2017—Rev. A to Rev. B

Changes to Endnote 4, Table 1	3
Added Endnote 1, Table 2	4

11/2016—Rev. 0 to Rev. A

Changes to Figure 15	9
----------------------------	---

6/2016—Revision 0: Initial Version

SPECIFICATIONS

$V_{DD} = 1.65\text{ V to }2.75\text{ V}$, $GND = 0\text{ V}$, input power = 0 dBm, temperature range = $-55^{\circ}\text{C to }+125^{\circ}\text{C}$, unless otherwise noted.

Table 1.

Parameter	Symbol	Test Conditions/Comments	Min	Typ ¹	Max	Unit
AC ELECTRICAL CHARACTERISTICS						
-3 dB Frequency ²				2.5		GHz
Insertion Loss	S12, S21	DC to 100 MHz; $V_{DD} = 2.5\text{ V} \pm 10\%$; see Figure 18		0.5	1	dB
		500 MHz; $V_{DD} = 2.5\text{ V} \pm 10\%$		0.7	1.2	dB
		1000 MHz; $V_{DD} = 2.5\text{ V} \pm 10\%$		1.1	1.8	dB
Isolation—RFC to RF1x	S12, S21	100 MHz; see Figure 17	51	60		dB
		500 MHz; see Figure 17	35	45		dB
		1000 MHz; see Figure 17	30	37		dB
Crosstalk	S12, S21	100 MHz; see Figure 19	50	58		dB
		500 MHz; see Figure 19	32	35		dB
		1000 MHz; see Figure 19	30	35		dB
Return Loss ²	S11, S22					
On Channel		DC to 100 MHz	19	27		dB
		500 MHz		26		dB
		1000 MHz		18		dB
Off Channel		DC to 100 MHz	14	22		dB
		500 MHz		19		dB
		1000 MHz		18		dB
Timing						
On Switching Time ²	$t_{ON(\overline{EN})}$	50% \overline{EN} to 90% RF; see Figure 15		8.5	10	ns
Off Switching Time ²	$t_{OFF(\overline{EN})}$	50% \overline{EN} to 10% RF; see Figure 15		13	16	ns
Transition Time	t_{TRANS}	50% A0/A1 to 10% RF		12	15	ns
Rise Time ²	t_{RISE}	10% to 90% RF; see Figure 16		3	5	ns
Fall Time ²	t_{FALL}	90% to 10% RF; see Figure 16		7.5	11	ns
Third-Order Intermodulation Intercept	IP3	900 MHz/901 MHz, 4 dBm; see Figure 21	25	31		dBm
Video Feedthrough ³		See Figure 20		3		mV p-p
INPUT POWER						
1 dB Input Compression	P1dB	1000 MHz ⁴ ; see Figure 22		16		dBm
DC ELECTRICAL CHARACTERISTICS						
Input High Voltage	V_{INH}	$V_{DD} = 2.25\text{ V to }2.75\text{ V}$ $V_{DD} = 1.65\text{ V to }1.95\text{ V}$	1.7			V
			0.65 V_{DD}			V
Input Low Voltage	V_{INL}	$V_{DD} = 2.25\text{ V to }2.75\text{ V}$ $V_{DD} = 1.65\text{ V to }1.95\text{ V}$			0.7	V
					0.35 V_{DD}	V
Input Leakage Current	I_I	$0\text{ V} \leq V_{IN} \leq 2.75\text{ V}$		± 0.1	± 1	μA
CAPACITANCE²						
RF Port On Capacitance	$C_{RF\ ON}$	$f = 1\text{ MHz}$		3		pF
Digital Input Capacitance	C			2		pF
POWER REQUIREMENTS						
V_{DD}			1.65		2.75	V
Quiescent Power Supply Current	I_{DD}	Digital inputs = 0 V or V_{DD}		0.1	2.5	μA

¹ Typical values are at $V_{DD} = 2.5\text{ V}$ and 25°C , unless otherwise stated.

² Guaranteed by design, not subject to production test.

³ Video feedthrough is the dc transience at the output of any port of the switch when the control voltage is switched from high to low or low to high in a 50 Ω test setup, measured with 1 ns rise time pulses and 500 MHz bandwidth.

⁴ Less than 100 MHz, refer to the [AN-952 Application Note](#) for more information about power handling.

CONTINUOUS CURRENT PER CHANNEL

Table 2.

Parameter	25°C	85°C	105°C	125°C	Unit	Test Conditions/Comments
CONTINUOUS CURRENT PER CHANNEL ¹						20-lead LFCSP, $\theta_{JA} = 30.4^{\circ}\text{C/W}$, dc bias = 0.5 V
$V_{DD} = 2.75\text{ V}, V_{SS} = 0\text{ V}$	93.1	10.8	5.9	3.3	mA maximum	
$V_{DD} = 1.65\text{ V}, V_{SS} = 0\text{ V}$	82.6	10.8	5.9	3.3	mA maximum	

¹ Guaranteed by design, not production tested.

ABSOLUTE MAXIMUM RATINGS

$T_A = 25^\circ\text{C}$, unless otherwise noted.

Table 3.

Parameter	Rating
V_{DD} to GND ¹	-0.5 V to +4 V
Inputs to GND ¹	-0.5 V to $V_{DD} + 0.3\text{V}$ ²
Continuous Current	Data ³ + 15%
Input Power ⁴	18 dBm
Operating Temperature Range (Industrial)	-55°C to +125°C
Storage Temperature Range	-65°C to +150°C
Junction Temperature	150°C
Lead Temperature, Soldering (10 sec)	300°C
IR Reflow, Peak Temperature (<20 sec)	235°C
Electrostatic Discharge (ESD)	1 kV

¹ Tested at +125°C.

² RFx off port inputs to ground = -0.5 V to $V_{DD} - 0.5\text{V}$.

³ See Table 2.

⁴ Input power is tested with switch in both open and close position. Power is applied on RFx, while RFC is terminated to a 50 Ω resistor to GND.

Stresses at or above those listed under Absolute Maximum Ratings may cause permanent damage to the product. This is a stress rating only; functional operation of the product at these or any other conditions above those indicated in the operational section of this specification is not implied. Operation beyond the maximum operating conditions for extended periods may affect product reliability.

THERMAL RESISTANCE

Thermal performance is directly linked to printed circuit board (PCB) design and operating environment. Careful attention to PCB thermal design is required.

Table 4. Thermal Resistance

Package Type	θ_{JA}	θ_{JC}	Unit
CP-20-6 ¹	30.4	2.83	$^\circ\text{C}/\text{W}$

¹ Test condition: thermal impedance simulated values are based on JEDEC 252P thermal test board with four thermal vias. See JEDEC JESD51.

Table 5. Truth Table

A1	A0	EN	On Switch ¹
X ²	X ²	1	None
0	0	0	RF1
0	1	0	RF2
1	0	0	RF3
1	1	0	RF4

¹ Off switches have 50 Ω termination to GND.

² X means don't care.

ESD CAUTION



ESD (electrostatic discharge) sensitive device.

Charged devices and circuit boards can discharge without detection. Although this product features patented or proprietary protection circuitry, damage may occur on devices subjected to high energy ESD. Therefore, proper ESD precautions should be taken to avoid performance degradation or loss of functionality.

PIN CONFIGURATION AND FUNCTION DESCRIPTIONS

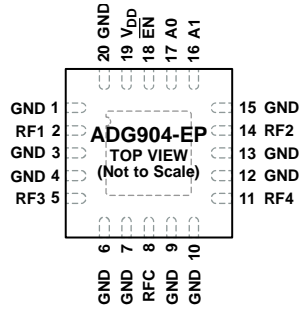

NOTES
 1. THE EXPOSED PAD IS TIED TO THE SUBSTRATE, GND.

14326-003

Figure 2. Pin Configuration

Table 6. Pin Function Descriptions

Pin No.	Mnemonic	Function
0	EPAD	Exposed Pad. The exposed pad is tied to the substrate, GND.
1, 3, 4, 6, 7, 9, 10, 12, 13, 15, 20	GND	Ground Reference Points for All Circuitry on the Device.
2	RF1	RF 1 Port.
5	RF3	RF 3 Port.
8	RFC	Common RF Port for Switch.
11	RF4	RF 4 Port.
14	RF2	RF 2 Port.
16	A1	Logic Control Input 1.
17	A0	Logic Control Input 0.
18	$\overline{\text{EN}}$	Active Low Digital Input. When high, the device is disabled and all switches are off. When low, Ax logic inputs determine on switches.
19	V _{DD}	Power Supply Input. This device operates from 1.65 V to 2.75 V. V _{DD} must be decoupled to GND.

TYPICAL PERFORMANCE CHARACTERISTICS

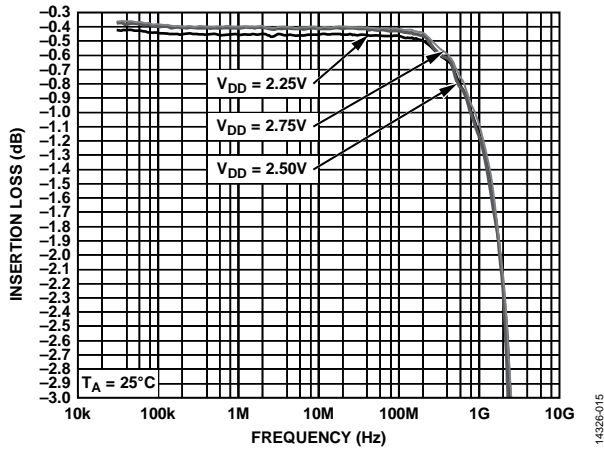

Figure 3. Insertion Loss vs. Frequency for $V_{DD} > 2.2$ V (RFx to RFC)

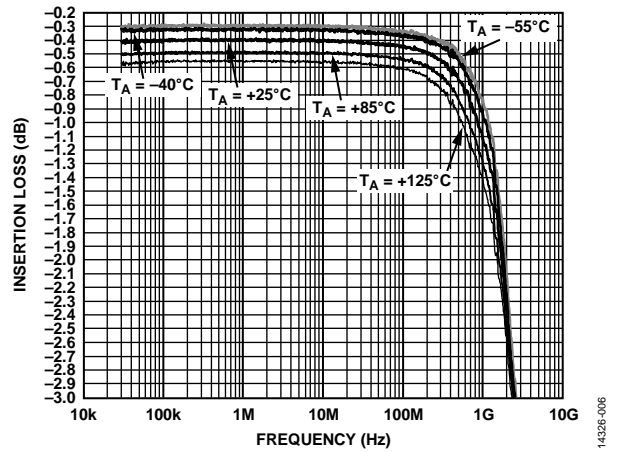

Figure 6. Insertion Loss vs. Frequency over Various Temperature (RFx to RFC)

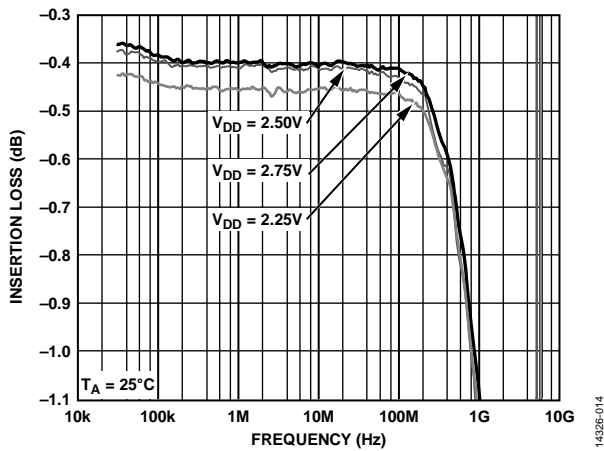

Figure 4. Insertion Loss vs. Frequency for $V_{DD} > 2.2$ V (RFx to RFC) Zoomed View of Figure 3

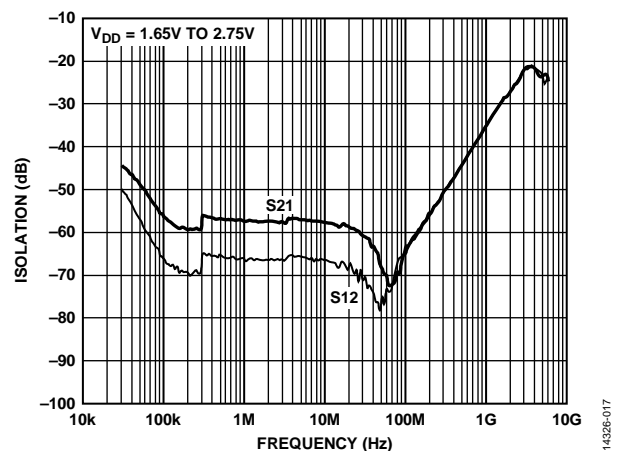

Figure 7. Isolation vs. Frequency over Supplies (RFx to RFC)

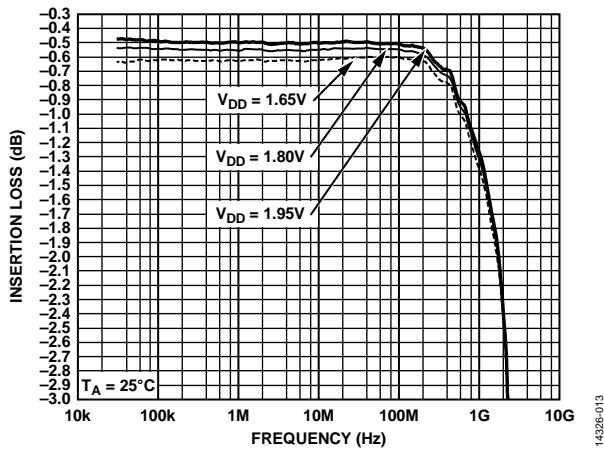

Figure 5. Insertion Loss vs. Frequency for $V_{DD} < 2$ V (RFx to RFC)

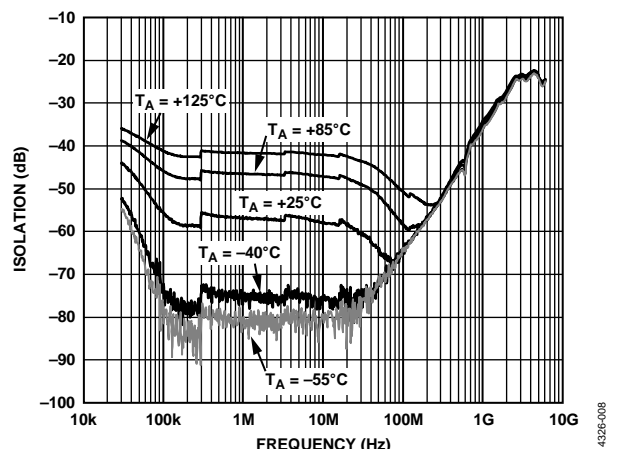

Figure 8. Isolation vs. Frequency over Various Temperature (RFx to RFC)

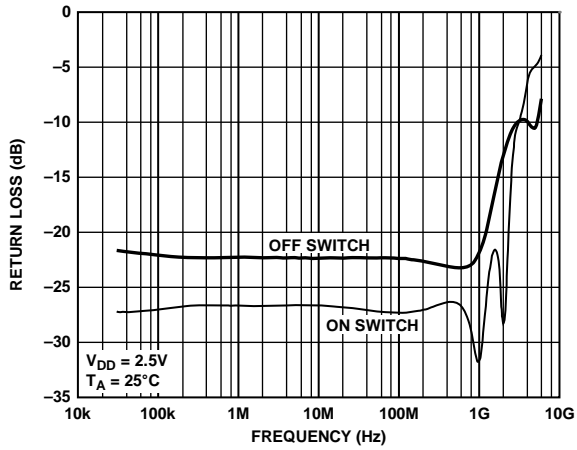

Figure 9. Return Loss vs. Frequency (RFx to RFC)

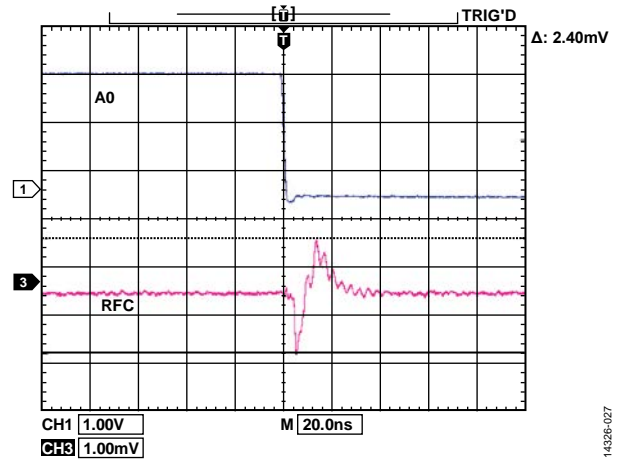

Figure 12. Video Feedthrough

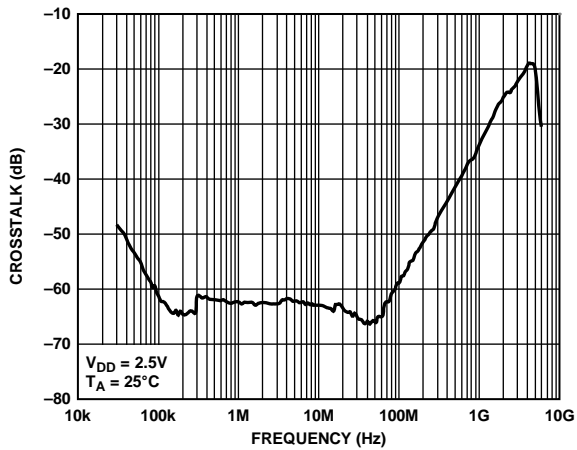

Figure 10. Crosstalk vs. Frequency

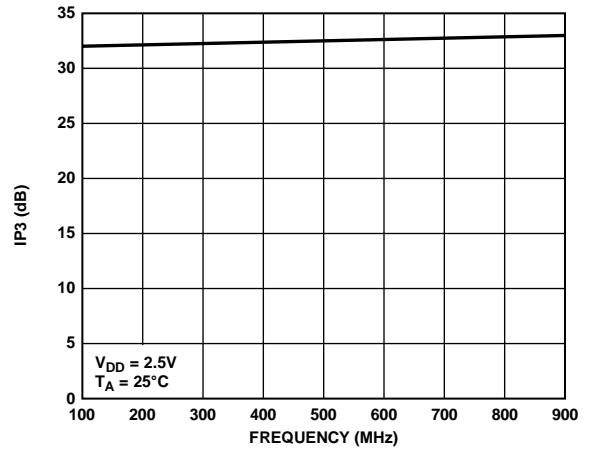

Figure 13. Third-Order Intermodulation Intercept (IP3) vs. Frequency

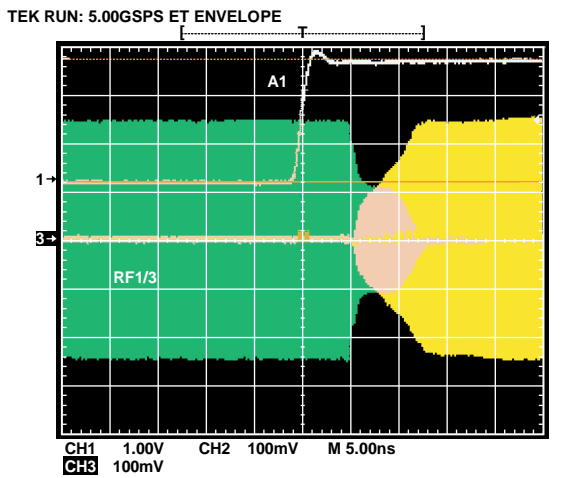

Figure 11. Switch Timing

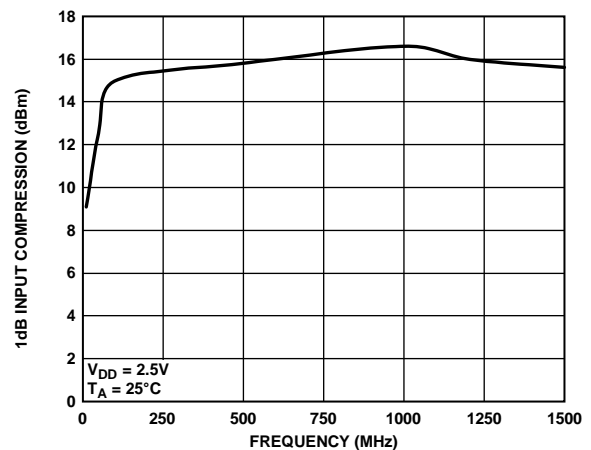

Figure 14. 1 dB Input Compression vs. Frequency (DC Bias Not Used)

TEST CIRCUITS

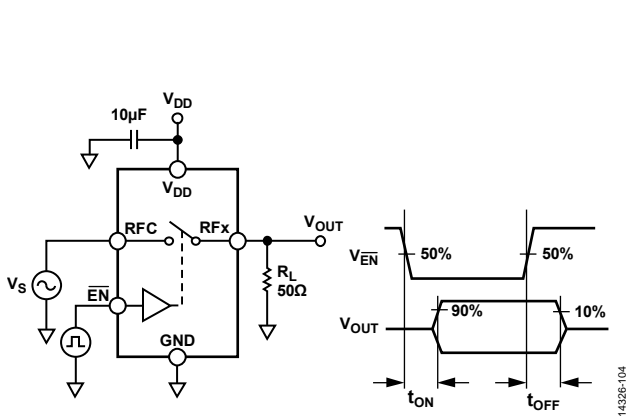

Figure 15. Switch Timing, $t_{ON(EN)}$ and $t_{OFF(EN)}$

14326-104

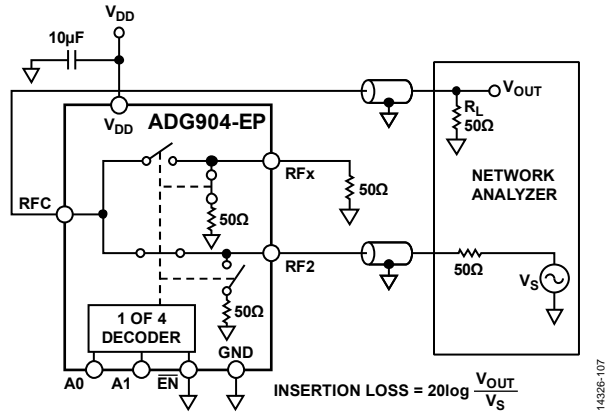

Figure 18. Insertion Loss

14326-107

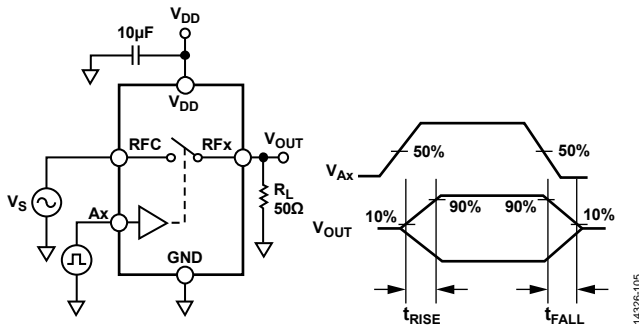

Figure 16. Switch Timing, t_{RISE} and t_{FALL}

14326-105

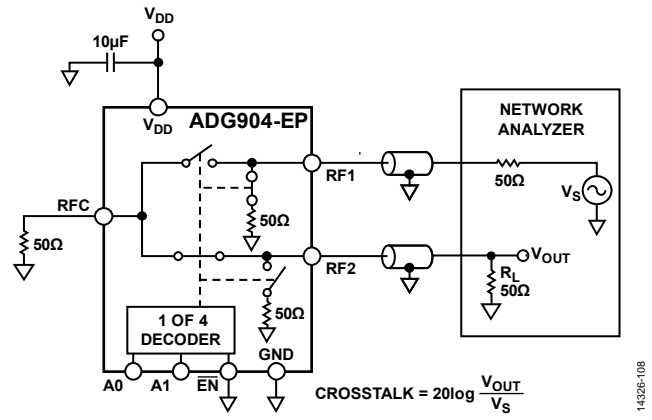

Figure 19. Crosstalk

14326-108

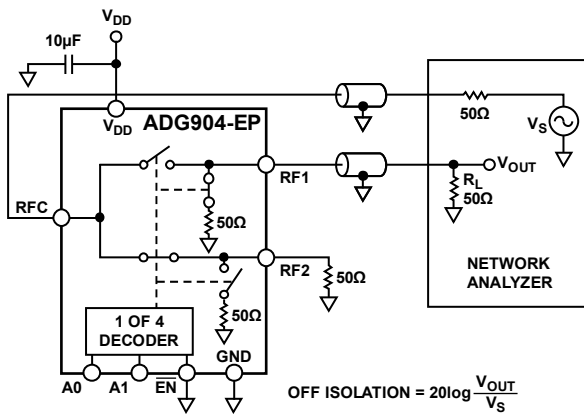

Figure 17. Off Isolation

14326-106

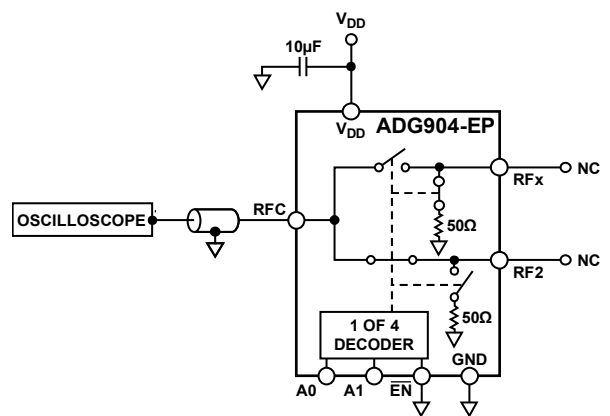

Figure 20. Video Feedthrough

14326-109

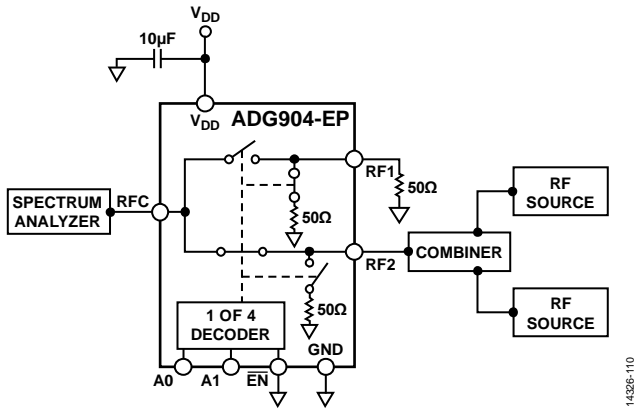

Figure 21. Third-Order Intermodulation Intercept (IP3)

14326-110

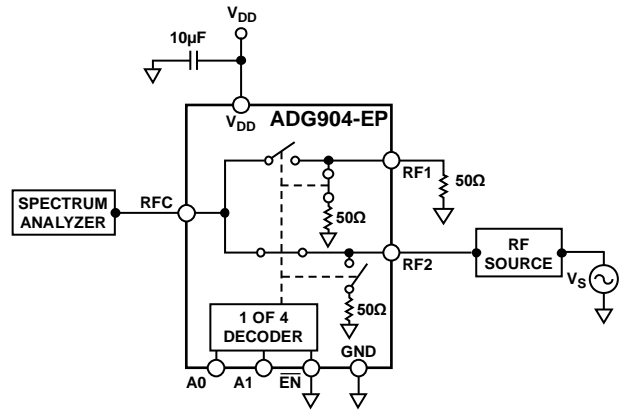
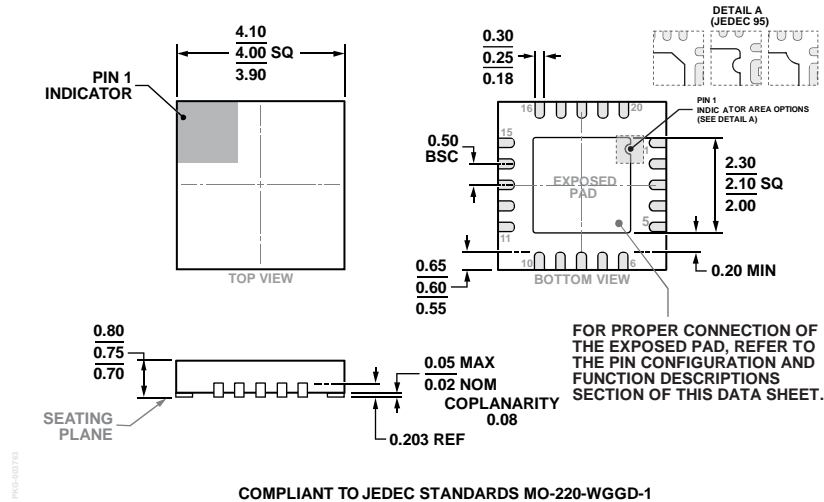

Figure 22. 1 dB Input Compression (P1dB)

14326-111

OUTLINE DIMENSIONS



COMPLIANT TO JEDEC STANDARDS MO-220-WGGD-1

Figure 23. 20-Lead Lead Frame Chip Scale Package [LFCSP]
 4 mm × 4 mm Body and 0.75 mm Package Height
 (CP-20-6)
 Dimensions shown in millimeters

ORDERING GUIDE

Model ¹	Temperature Range	Package Description	Package Option
ADG904SCPZ-EP	-55°C to +125°C	20-Lead Lead Frame Chip Scale Package [LFCSP]	CP-20-6
ADG904SCPZ-EP-RL7	-55°C to +125°C	20-Lead Lead Frame Chip Scale Package [LFCSP]	CP-20-6

¹ Z = RoHS Compliant Part.

Looking for pricing, stock, or lifecycle information?

Click below to explore more details on WIN SOURCE:

- ⊖ [View ADG904SCPZ-EP on WIN SOURCE](#)
- ⊖ [Analog Devices Inc. Information](#)

Optimize Your Supply Chain with WIN SOURCE Solutions

- ✓ Global Sourcing Solution
- ✓ Obsolete Management
- ✓ Cost Control Management
- ✓ Shortage Management
- ✓ Alternative Solution
- ✓ Excess Inventory Management