



**THE DATASHEET OF
NB3L8504SDTG**



2.5 V / 3.3 V 1:4 Differential Input to LVDS Fanout Buffer / Translator

NB3L8504S

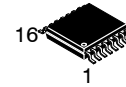

TSSOP-16
DT SUFFIX
CASE 948F

Description

The NB3L8504S is a differential 1:4 LVDS fanout buffer/translator with OE control for each differential output. The differential inputs which can be driven by either a differential or single-ended input, can accept various logic level standards such as LVPECL, LVDS, HSTL, HCSL and SSTL. These signals are then translated to four identical LVDS copies of the input up to 700 MHz. As such, the NB3L8504S is ideal for Clock distribution applications that require low skew.

The NB3L8504S is offered in the TSSOP-16 package.

Features

- Four Differential LVDS Outputs
- Each Differential Output has OE Control
- 700 MHz Maximum Output Frequency
- 660 ps Max Output Rise and Fall Times, LVCMOS
- Translates Differential Input to LVDS Levels
- Additive Phase Jitter RMS: < 100 fs Typical
- 50 ps Maximum Output Skew
- 350 ps Maximum Part-to-part Skew
- 1.3 ns Maximum Propagation Delay
- Operating Range: $V_{CC} = 2.5 V \pm 5\%$ or $3.3 V \pm 10\%$
- $-40^{\circ}C$ to $+85^{\circ}C$ Ambient Operating Temperature
- 16-Pin TSSOP, 4.4 mm x 5.0 mm x 0.925 mm
- These are Pb-Free Devices

Applications

- Telecom
- Ethernet
- Networking
- SONET

MARKING DIAGRAM



- A = Assembly Location
- L = Wafer Lot
- Y = Year
- W = Work Week
- = Pb-Free Package

(Note: Microdot may be in either location)

*For additional marking information, refer to Application Note [AND8002/D](#).

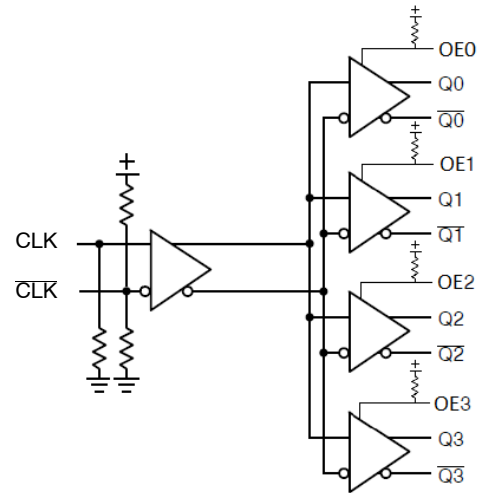

Figure 1. Logic Diagram

ORDERING INFORMATION

See detailed ordering and shipping information on page 9 of this data sheet.

NB3L8504S

Table 1. PIN DESCRIPTIONS AND CHARACTERISTICS

Pin	Name	I/O	Description
1	OE0	LVTTL/LVCMOS Input	Output Enable pin for Q0, $\overline{Q0}$ outputs. Defaults High when left open; internal pull-up resistor.
2	OE1	LVTTL/LVCMOS Input	Output Enable pin for Q1, $\overline{Q1}$ outputs. Defaults High when left open; internal pull-up resistor.
3	OE2	LVTTL/LVCMOS Input	Output Enable pin for Q2, $\overline{Q2}$ outputs. Defaults High when left open; internal pull-up resistor.
4	VDD	Power	3.3 V / 2.5 V Positive Supply Voltage.
5	GND	Power	3.3 V / 2.5 V Negative Supply Voltage.
6	CLK	Multi-Level Input	Non-inverting differential Clock input. Defaults Low when left open; internal pull-down resistor.
7	$\overline{\text{CLK}}$	Multi-Level Input	Inverting differential Clock input. Defaults to VDD/2 when left open; internal pull-up and pull-down resistors.
8	OE3	LVTTL/LVCMOS Input	Output Enable pin for Q3, $\overline{Q3}$ outputs. Defaults High when left open; internal pull-up resistor.
9	$\overline{Q3}$	LVDS Output	Inverting differential Clock output.
10	Q3	LVDS Output	Non-inverting differential Clock output.
11	$\overline{Q2}$	LVDS Output	Inverting differential Clock output.
12	Q2	LVDS Output	Non-inverting differential Clock output.
13	$\overline{Q1}$	LVDS Output	Inverting differential Clock output.
14	Q1	LVDS Output	Non-inverting differential Clock output.
15	$\overline{Q0}$	LVDS Output	Inverting differential Clock output.
16	Q0	LVDS Output	Non-inverting differential Clock output.

1. All VDD and GND pins must be externally connected to a power supply for proper operation.

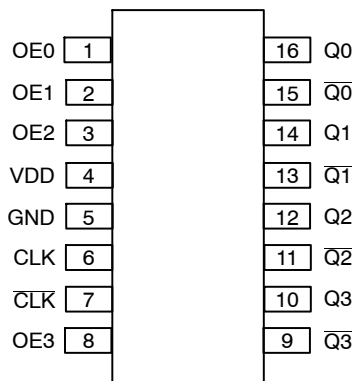

Figure 2. NB3L8504S Pinout, 16-pin TSSOP (Top View)

Table 2. OUTPUT ENABLE FUNCTION TABLE

OE[3:0]	Outputs – Q[0:3], \overline{Q} [0:3]
LOW	High Impedance
HIGH (Default)	Active

NB3L8504S

Table 3. ATTRIBUTES

Characteristics		Value
ESD Protection	Human Body Model	> 2 kV
	Machine Model	> 200 V
R _{PU} – Input Pull-up Resistor		50 kΩ
R _{PD} – Input Pull-down Resistor		50 kΩ
C _{IN} – Input Capacitance		4 pF
R _{IN} – Input Impedance		10 kΩ
Moisture Sensitivity (Note 2)	TSSOP-16	Level 1
Flammability Rating	Oxygen Index: 28 to 34	UL 94 V-0 @ 0.125 in
Transistor Count		371
Meets or exceeds JEDEC Spec EIA/JESD78 IC Latchup Test		

2. For additional information, see Application Note [AND8003/D](#).

Table 4. MAXIMUM RATINGS

Symbol	Parameter	Condition		Rating	Unit
V _{DD}		GND = 0 V		4.6	V
V _{IN}		GND = 0 V		-0.5 to V _{DD} +0.5	V
I _{out}	Continuous Current Surge Current	LVDS Outputs		10	mA
				15	mA
I _{OSC}	Output Short Circuit Current Line-to-Line (Q to \bar{Q}) Line-to-GND (Q or \bar{Q} to GND)	Q or \bar{Q} Q to \bar{Q} to GND	Continuous Continuous	12	mA
				24	mA
T _A	Operating Temperature Range	TSSOP-16		-40 to +85	°C
T _{stg}	Storage Temperature Range			-65 to +150	°C
θ _{JA}	Thermal Resistance (Junction-to-Ambient) (Note 3)	0 lfpm	TSSOP-16	138	°C/W
		500 lfpm	TSSOP-16	108	°C/W
θ _{JC}	Thermal Resistance (Junction-to-Case)	(Note 3)	TSSOP-16	33 – 36	°C/W
T _{sol}	Wave Solder (Pb-Free)			265	°C

Stresses exceeding those listed in the Maximum Ratings table may damage the device. If any of these limits are exceeded, device functionality should not be assumed, damage may occur and reliability may be affected.

3. JEDEC standard multilayer board – 2S2P (2 signal, 2 power) with 8 filled thermal vias under exposed pad.

NB3L8504S

Table 5. DC CHARACTERISTICS $V_{DD} = 2.5\text{ V} \pm 5\%$ or $3.3\text{ V} \pm 10\%$; $GND = 0\text{ V}$; $T_A = -40^\circ\text{C}$ to 85°C

Symbol	Characteristic	Min	Typ	Max	Unit
--------	----------------	-----	-----	-----	------

POWER SUPPLY / CURRENT (Note 4)

V_{DD}	Power Supply Voltage	$V_{DD} = 3.3\text{ V}$ $V_{DD} = 2.5\text{ V}$	2.97 2.375	3.3 2.5	3.63 2.625	V
I_{DD}	Power Supply Current for V_{DD}			41	50	mA

LVDS OUTPUTS (Note 5)

V_{OD}	Differential Output Voltage (Figure 12) (Notes 6 and 7)	250	350	450	mV
ΔV_{OD}	V_{OD} Magnitude Change (Figure 12) (Notes 6 and 7)			50	mV
V_{OS}	Offset Voltage (Figure 13) (Notes 6 and 7)	1075	1250	1375	mV
ΔV_{OS}	V_{OS} Magnitude Change (Figure 13) (Notes 6 and 7)			50	mV
V_{OH}	Output HIGH Voltage		1425	1600	mV
V_{OL}	Output LOW Voltage	900	1075		mV

DIFFERENTIAL INPUTS DRIVEN DIFFERENTIALLY (see Figure 5 & 6) (Note 11)

V_{IHD}	Differential Input HIGH Voltage	500		$V_{DD} - 850$	mV
V_{ILD}	Differential Input LOW Voltage	-300		$V_{IHD} - 150$	mV
V_{ID}	Differential Input Voltage ($V_{IHD} - V_{ILD}$)	150		1300	mV
V_{IHCMR}	Input Common Mode Voltage Range (Differential Configuration) (Note 10) (Figure 7)	$GND + 0.5$		$V_{DD} - 850$	mV
I_{IH}	Input HIGH Current, $V_{DD} = V_{IN} = 3.63\text{ V}$	CLK, CLK		150	μA
I_{IL}	Input LOW Current, $V_{DD} = 3.63\text{ V}$, $V_{IN} = 0\text{ V}$	CLK CLK	-5 -150		μA

LVC MOS – OE Control Inputs

V_{IH}	Input HIGH Voltage	2.0		$V_{DD} + 0.3$	V
V_{IL}	Input LOW Voltage	-0.3		0.8	V
I_{IH}	Input HIGH Current, $V_{DD} = V_{IN} = 3.63\text{ V}$			5	μA
I_{IL}	Input LOW Current, $V_{DD} = 3.63\text{ V}$, $V_{IN} = 0\text{ V}$		-150		μA

Product parametric performance is indicated in the Electrical Characteristics for the listed test conditions, unless otherwise noted. Product performance may not be indicated by the Electrical Characteristics if operated under different conditions.

NOTE: Device will meet the specifications after thermal equilibrium has been established when mounted in a test socket or printed circuit board with maintained transverse airflow greater than 500 lfm. Electrical parameters are guaranteed only over the declared operating temperature range. Functional operation of the device exceeding these conditions is not implied. Device specification limit values are applied individually under normal operating conditions and not valid simultaneously.

4. Input pins open and output pins loaded with $R_L = 100\ \Omega$ across differential.
5. LVDS outputs require $100\ \Omega$ receiver termination resistor between diff. pair. See Figure 14.
6. $V_{OS}\text{ max} + \frac{1}{2} V_{OD}\text{ max}$. Also see Figures 12 and 13.
7. $V_{OS}\text{ min} - \frac{1}{2} V_{OD}\text{ max}$. Also see Figures 12 and 13.
8. V_{IH} , V_{IL} , V_{th} , and V_{ISE} parameters must be complied with simultaneously.
9. V_{th} is applied to the complementary input when operating in single-ended mode.
10. $V_{IHCMR}\text{ max}$ varies 1:1 with V_{DD} , $V_{IHCMR}\text{ min}$ varies 1:1 with GND .
11. V_{IHD} , V_{ILD} , V_{ID} and V_{IHCMR} parameters must be complied with simultaneously.

NB3L8504S

Table 6. AC CHARACTERISTICS $V_{DD} = 2.5\text{ V} \pm 5\%$ or $3.3\text{ V} \pm 10\%$; $GND = 0\text{ V}$; $T_A = -40^\circ\text{C}$ to 85°C (Note 12) (Figure 10)

Symbol	Characteristic	Min	Typ	Max	Unit
f_{MAX}	Input Clock Frequency $V_{OUTPP} \geq 250\text{ mV}$ @ $V_{INPPmax}$			700	MHz
V_{OUTPP}	Output Voltage Amplitude (@ $V_{INPPmin}$) $f_{in} \leq 700\text{ MHz}$ (See Figure 3)	250	350		mV
t_{pd}	Differential Input to Differential Output Propagation Delay at f_{MAX} @ $V_{DD} = 3.3\text{ V}$	0.9		1.3	ns
$t_{jit}(\phi)$	Additive Phase Jitter RMS (Figure 4) Integration Range: 12 kHz – 20 MHz		$f_{out} = 156.25\text{ MHz}$ 0.07 $f_{out} = 100\text{ MHz}$ 0.10	0.08 0.105	ps
$t_{SKEW(o-o)}$	Output-to-output Skew (Note 14) (Figure 8)			50	ps
$T_{SKEW(pp)}$	Part-to-part Skew (Note 14)			350	ps
t_r / t_f	Output Rise/Fall Times @ 50 MHz, 20% – 80%	180	350	660	ps
t_{DC}	Output Clock Duty Cycle (Input Duty Cycle = 50%)	45	50	55	%
V_{INPP}	Input Voltage Swing (Differential Configuration) (Note 13)	150		1300	mV

Product parametric performance is indicated in the Electrical Characteristics for the listed test conditions, unless otherwise noted. Product performance may not be indicated by the Electrical Characteristics if operated under different conditions.

NOTE: Device will meet the specifications after thermal equilibrium has been established when mounted in a test socket or printed circuit board with maintained transverse airflow greater than 500 lfm. Electrical parameters are guaranteed only over the declared operating temperature range. Functional operation of the device exceeding these conditions is not implied. Device specification limit values are applied individually under normal operating conditions and not valid simultaneously.

12. Measured by forcing a 50% duty cycle clock source. All LVDS output loading with an external $R_L = 100\ \Omega$ across Q & \bar{Q} .

13. $V_{INPP(max)}$ cannot exceed V_{DD} . Input voltage swing is a single-ended measurement operating in differential mode.

14. Skew is measured between outputs under identical transition at 50 MHz.

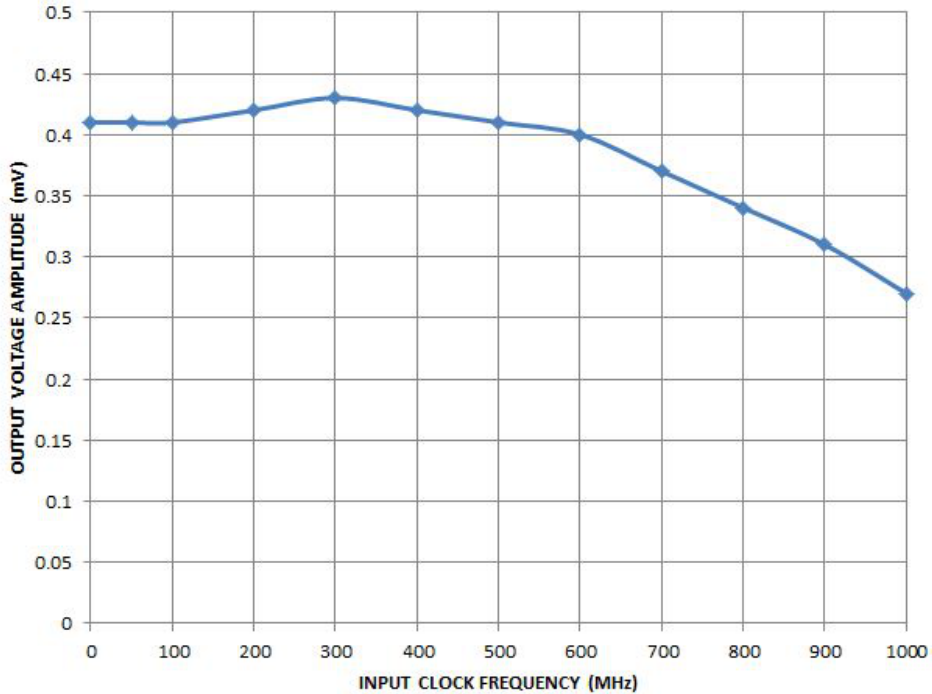

Figure 3. Output Voltage Amplitude (V_{OUTPP}) vs. Input Clock Frequency (f_{in}) and Temperature (@ $V_{DD} = 2.5\text{ V}$)

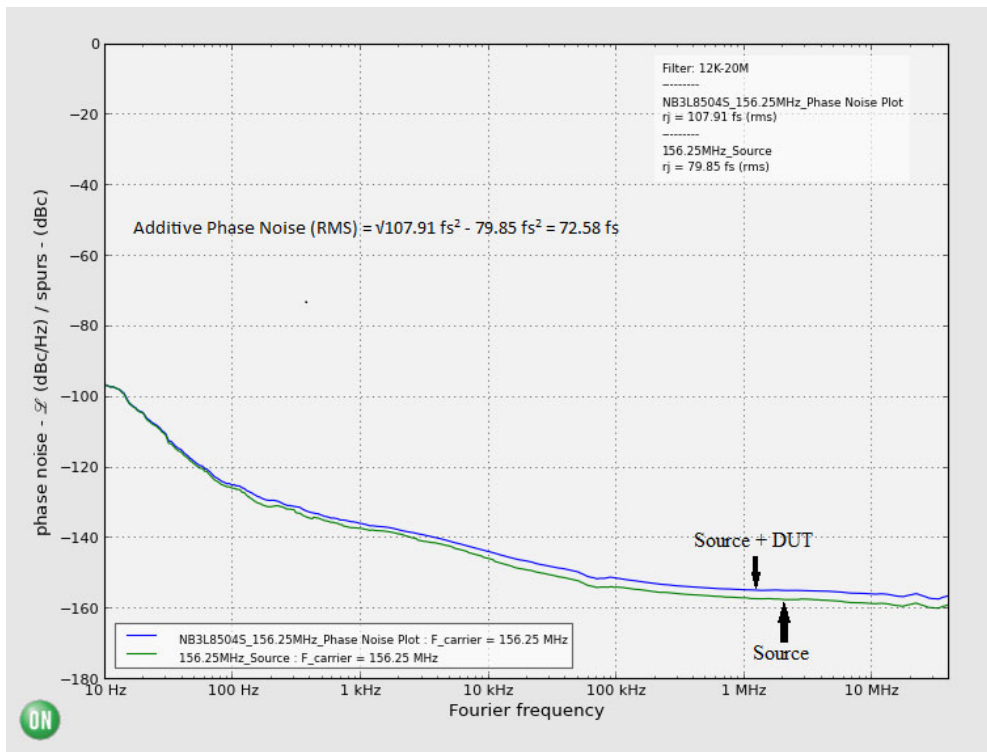

Figure 4. Additive Phase Jitter

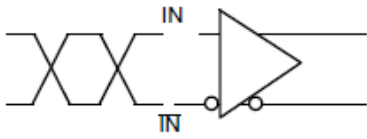

Figure 5. Differential Inputs Driven Differentially

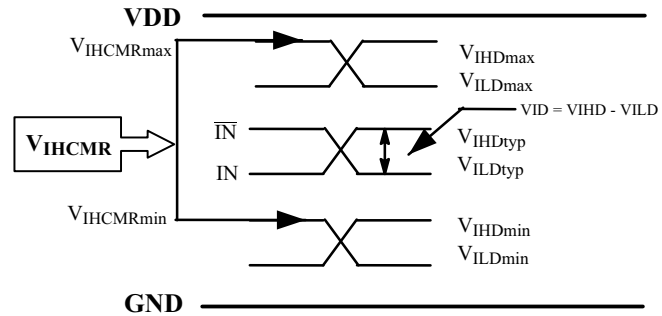

Figure 7. VIHCMR Diagram

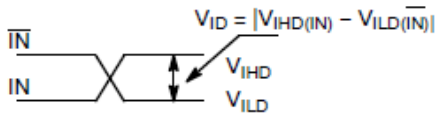

Figure 6. Differential Inputs Driven Differentially

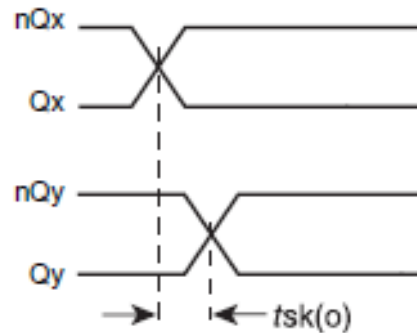

Figure 8. Output-to-Output Skew

NB3L8504S

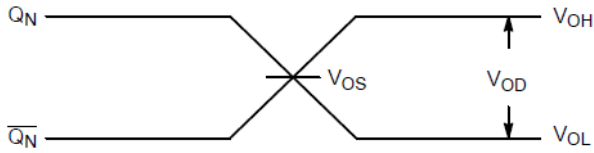

Figure 9. LVDS Output

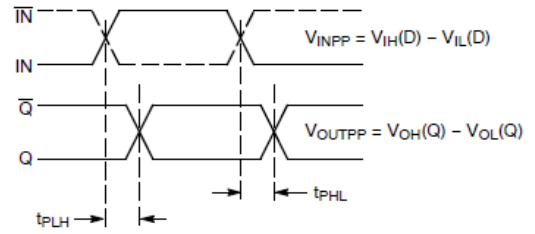

Figure 10. AC Reference Measurements

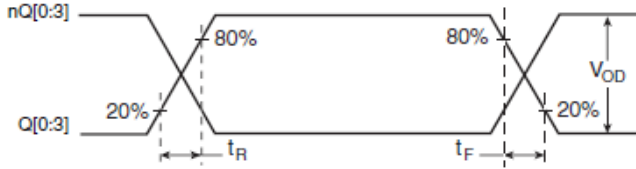

Figure 11. LVDS Output

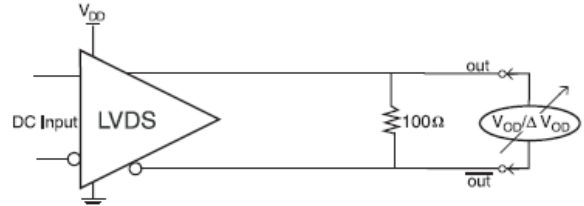

Figure 12. V_{OD} and ΔV_{OD}

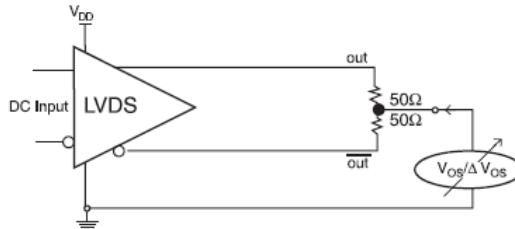

Figure 13. V_{OS} and ΔV_{OS}

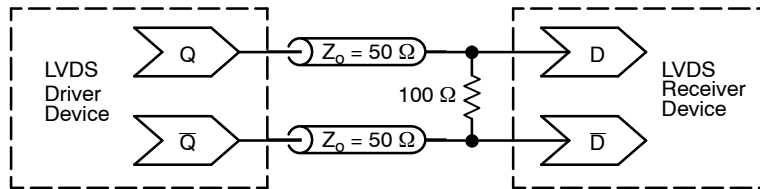

Figure 14. Typical LVDS Termination for Output Driver and Device Evaluation

NB3L8504S

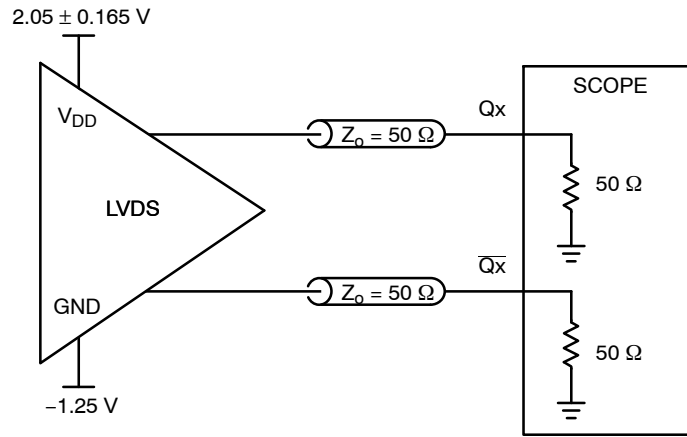

Figure 15. Typical Test Setup and Termination for Evaluation. The $V_{DD} = 2.05 \text{ V} \pm 0.165 \text{ V}$ and GND of -1.25 Split Supply Allows a Direct Connection to an Oscilloscope $50 \text{ } \Omega$ Input Module

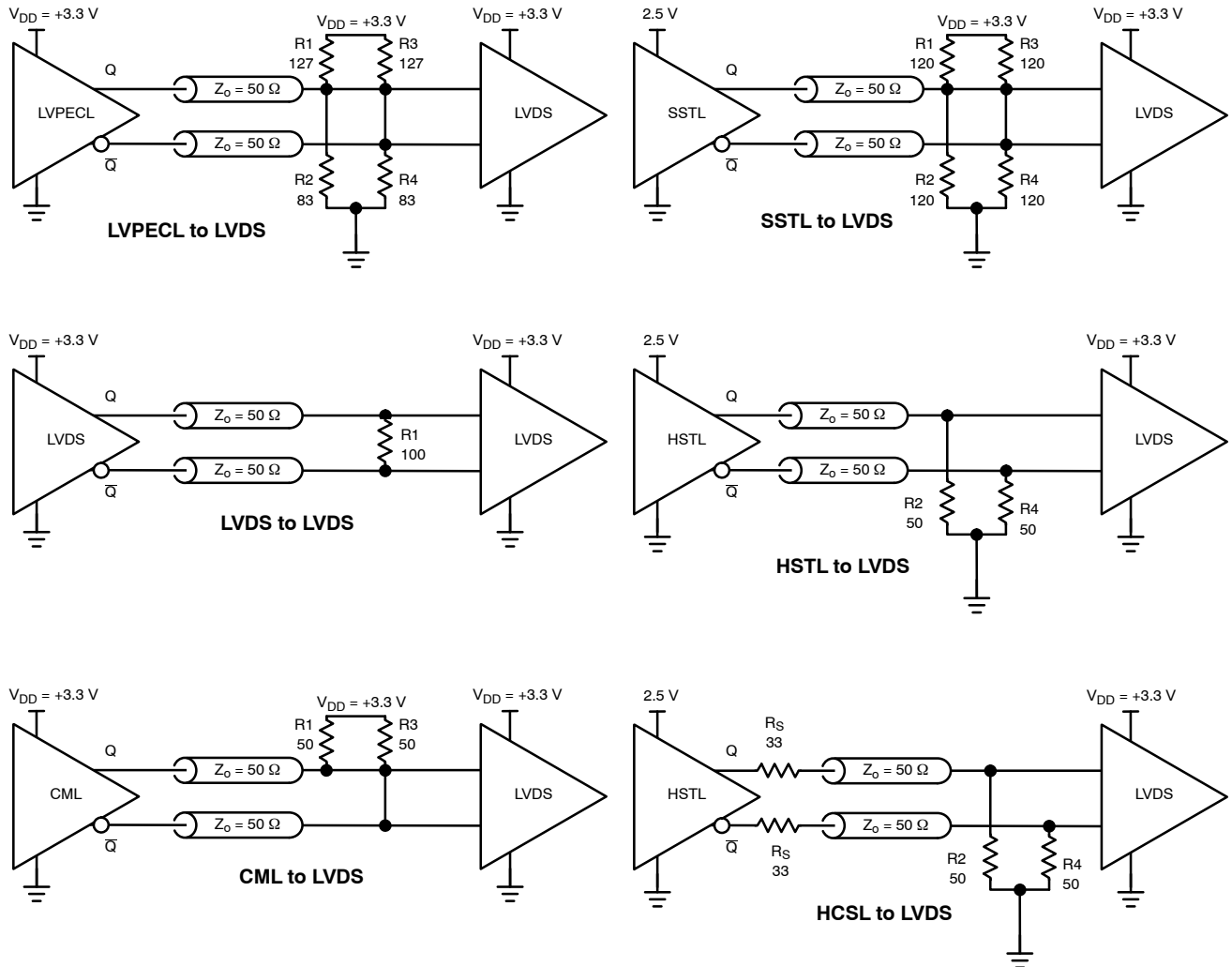

Figure 16. Differential Input Interface from LVPECL, CML, LVDS, HSTL, SSTL or HCSL

NB3L8504S

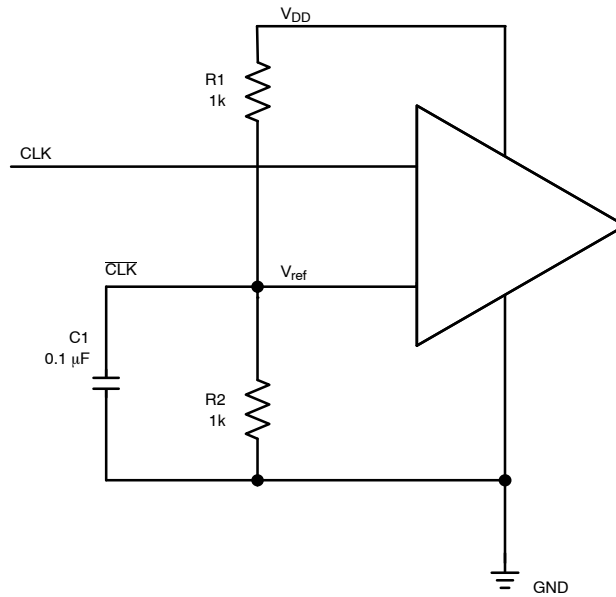

Figure 17. Differential Input Driven Single-ended

Differential Clock Input to Accept Single-ended Input

Figure 17 shows how the CLK input can be driven by a single-ended Clock signal. C1 is connected to the V_{ref} node

as a bypass capacitor. Locate these components close the device pins. R1 and R2 must be adjusted to position V_{ref} to the center of the input swing on CLK.

Table 7. ORDERING INFORMATION

Device	Package	Shipping
NB3L8504SDTG	TSSOP-16 (Pb-Free)	96 Units / Tube
NB3L8504SDTR2G	TSSOP-16 (Pb-Free)	2500 / Tape & Reel

†For information on tape and reel specifications, including part orientation and tape sizes, please refer to our Tape and Reel Packaging Specifications Brochure, [BRD8011/D](#).

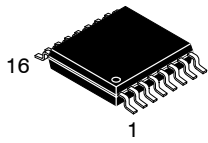

TSSOP-16 WB
CASE 948F
ISSUE B

DATE 19 OCT 2006

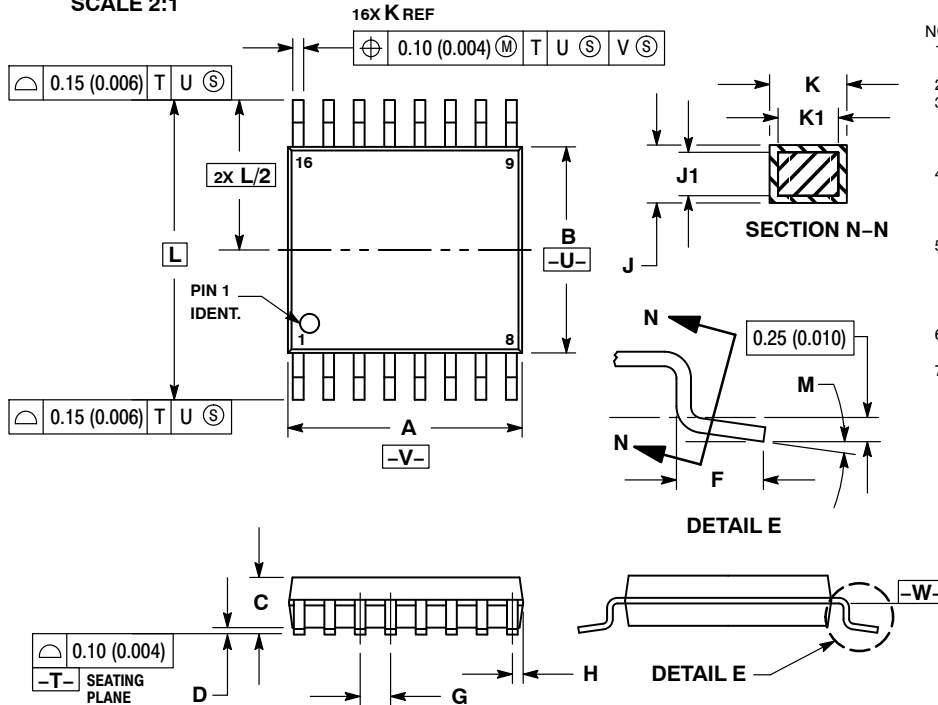

- NOTES:
1. DIMENSIONING AND TOLERANCING PER ANSI Y14.5M, 1982.
 2. CONTROLLING DIMENSION: MILLIMETER.
 3. DIMENSION A DOES NOT INCLUDE MOLD FLASH, PROTRUSIONS OR GATE BURRS. MOLD FLASH OR GATE BURRS SHALL NOT EXCEED 0.15 (0.006) PER SIDE.
 4. DIMENSION B DOES NOT INCLUDE INTERLEAD FLASH OR PROTRUSION. INTERLEAD FLASH OR PROTRUSION SHALL NOT EXCEED 0.25 (0.010) PER SIDE.
 5. DIMENSION K DOES NOT INCLUDE DAMBAR PROTRUSION. ALLOWABLE DAMBAR PROTRUSION SHALL BE 0.08 (0.003) TOTAL IN EXCESS OF THE K DIMENSION AT MAXIMUM MATERIAL CONDITION.
 6. TERMINAL NUMBERS ARE SHOWN FOR REFERENCE ONLY.
 7. DIMENSION A AND B ARE TO BE DETERMINED AT DATUM PLANE -W-.

DIM	MILLIMETERS		INCHES	
	MIN	MAX	MIN	MAX
A	4.90	5.10	0.193	0.200
B	4.30	4.50	0.169	0.177
C	---	1.20	---	0.047
D	0.05	0.15	0.002	0.006
F	0.50	0.75	0.020	0.030
G	0.65 BSC		0.026 BSC	
H	0.18	0.28	0.007	0.011
J	0.09	0.20	0.004	0.008
J1	0.09	0.16	0.004	0.006
K	0.19	0.30	0.007	0.012
K1	0.19	0.25	0.007	0.010
L	6.40 BSC		0.252 BSC	
M	0°	8°	0°	8°

RECOMMENDED
SOLDERING FOOTPRINT*

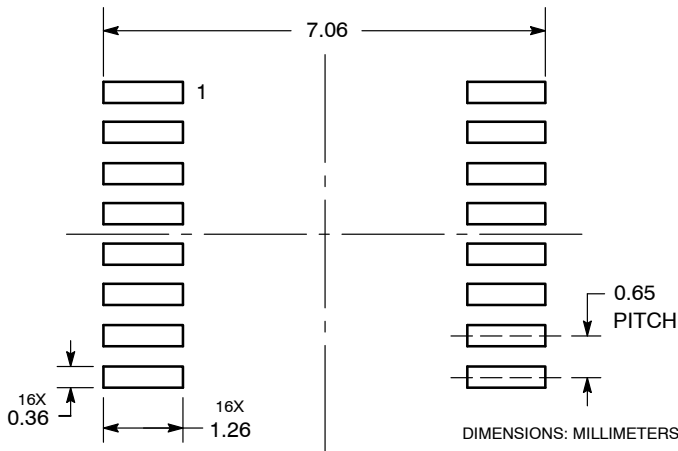

GENERIC
MARKING DIAGRAM*

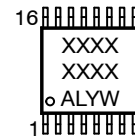

- XXXX = Specific Device Code
- A = Assembly Location
- L = Wafer Lot
- Y = Year
- W = Work Week
- G or ■ = Pb-Free Package

*This information is generic. Please refer to device data sheet for actual part marking. Pb-Free indicator, "G" or microdot "■", may or may not be present. Some products may not follow the Generic Marking.

*For additional information on our Pb-Free strategy and soldering details, please download the onsemi Soldering and Mounting Techniques Reference Manual, SOLDERRM/D.

DOCUMENT NUMBER:	98ASH70247A	Electronic versions are uncontrolled except when accessed directly from the Document Repository. Printed versions are uncontrolled except when stamped "CONTROLLED COPY" in red.
DESCRIPTION:	TSSOP-16	PAGE 1 OF 1

onsemi and onsemi are trademarks of Semiconductor Components Industries, LLC dba onsemi or its subsidiaries in the United States and/or other countries. onsemi reserves the right to make changes without further notice to any products herein. onsemi makes no warranty, representation or guarantee regarding the suitability of its products for any particular purpose, nor does onsemi assume any liability arising out of the application or use of any product or circuit, and specifically disclaims any and all liability, including without limitation special, consequential or incidental damages. onsemi does not convey any license under its patent rights nor the rights of others.

onsemi, **Onsemi**, and other names, marks, and brands are registered and/or common law trademarks of Semiconductor Components Industries, LLC dba "**onsemi**" or its affiliates and/or subsidiaries in the United States and/or other countries. **onsemi** owns the rights to a number of patents, trademarks, copyrights, trade secrets, and other intellectual property. A listing of **onsemi**'s product/patent coverage may be accessed at www.onsemi.com/site/pdf/Patent-Marking.pdf. **onsemi** reserves the right to make changes at any time to any products or information herein, without notice. The information herein is provided "as-is" and **onsemi** makes no warranty, representation or guarantee regarding the accuracy of the information, product features, availability, functionality, or suitability of its products for any particular purpose, nor does **onsemi** assume any liability arising out of the application or use of any product or circuit, and specifically disclaims any and all liability, including without limitation special, consequential or incidental damages. Buyer is responsible for its products and applications using **onsemi** products, including compliance with all laws, regulations and safety requirements or standards, regardless of any support or applications information provided by **onsemi**. "Typical" parameters which may be provided in **onsemi** data sheets and/or specifications can and do vary in different applications and actual performance may vary over time. All operating parameters, including "Typicals" must be validated for each customer application by customer's technical experts. **onsemi** does not convey any license under any of its intellectual property rights nor the rights of others. **onsemi** products are not designed, intended, or authorized for use as a critical component in life support systems or any FDA Class 3 medical devices or medical devices with a same or similar classification in a foreign jurisdiction or any devices intended for implantation in the human body. Should Buyer purchase or use **onsemi** products for any such unintended or unauthorized application, Buyer shall indemnify and hold **onsemi** and its officers, employees, subsidiaries, affiliates, and distributors harmless against all claims, costs, damages, and expenses, and reasonable attorney fees arising out of, directly or indirectly, any claim of personal injury or death associated with such unintended or unauthorized use, even if such claim alleges that **onsemi** was negligent regarding the design or manufacture of the part. **onsemi** is an Equal Opportunity/Affirmative Action Employer. This literature is subject to all applicable copyright laws and is not for resale in any manner.

ADDITIONAL INFORMATION

TECHNICAL PUBLICATIONS:

Technical Library: www.onsemi.com/design/resources/technical-documentation
onsemi Website: www.onsemi.com

ONLINE SUPPORT: www.onsemi.com/support

For additional information, please contact your local Sales Representative at www.onsemi.com/support/sales



Looking for pricing, stock, or lifecycle information?

Click below to explore more details on WIN SOURCE:

 [View NB3L8504SDTG on WIN SOURCE](#)

 [ON Semiconductor](#) Information

Optimize Your Supply Chain with WIN SOURCE Solutions

-  Global Sourcing Solution
-  Obsolete Management
-  Cost Control Management
-  Shortage Management
-  Alternative Solution
-  Excess Inventory Management