



**THE DATASHEET OF
W664GG6RB-06**





256M × 16 BIT DDR4 SDRAM

Table of Contents-

1.	General Description	5
2.	Features	6
3.	Order Information	6
4.	Key Parameters	7
5.	Ball Assignment	8
5.1	DDR4 SDRAM x16 Package VFBGA 96 Ball Assignment	8
6.	Ball Description	9
7.	Block Diagram	11
8.	Functional Description	12
8.1	Simplified DDR4 State Diagram	12
8.2	Basic Functionality	13
8.3	RESET and Initialization Procedure	13
8.3.1	Power-up Initialization Sequence	14
8.3.2	VDD Slew rate at Power-up Initialization Sequence	15
8.3.3	Reset Initialization with Stable Power	15
8.4	Mode Register Definition	16
8.4.1	Programming the mode registers	16
8.5	Mode Register	20
9.	Command Description and Operation	31
9.1	Command Truth Table	31
9.2	CKE Truth Table	33
9.3	No Operation (NOP) Command	33
9.4	Deselect Command	33
9.5	Burst Length, Type and Order	34
9.5.1	BL8 Burst order with CRC Enabled	34
9.6	DLL-off Mode & DLL on/off switching procedure	35
9.6.1	DLL on/off switching procedure	35
9.6.2	DLL "on" to DLL "off" Procedure	35
9.6.3	DLL "off" to DLL "on" Procedure	36
9.7	DLL-off Mode	37
9.8	Input Clock Frequency Change	38
9.9	Write Leveling	39
9.9.1	DRAM setting for write leveling & DRAM termination function in that mode	40
9.9.2	Procedure Description	40
9.9.3	Write Leveling Mode Exit	42
9.10	Temperature controlled Refresh modes	43
9.10.1	Normal temperature mode (-40°C ≤ TCASE ≤ 85°C)	43
9.10.2	Extended temperature mode (85°C ≤ TCASE ≤ 105°C)	43
9.11	Fine Granularity Refresh Mode	44
9.11.1	Mode Register and Command Truth Table	44
9.11.2	tREFI and tRFC parameters	44
9.11.3	Changing Refresh Rate	45
9.11.4	Usage with Temperature Controlled Refresh mode	46
9.11.5	Self Refresh entry and exit	46
9.12	Multi Purpose Register	46
9.12.1	DQ Training with MPR	46
9.12.2	MR3 definition	47
9.12.3	MPR Reads	47
9.12.4	MPR Writes	50
9.12.5	MPR Read Data format	53
9.13	Data Mask (DM) and Data Bus Inversion (DBI)	58



9.14	ZQ Calibration Commands.....	59
9.14.1	ZQ Calibration Description.....	59
9.15	DQ VREF Training.....	60
9.15.1	Example scripts for VREFDQ Calibration Mode.....	63
9.16	Per DRAM Addressability.....	65
9.17	CAL Mode (CS_n to Command Address Latency).....	68
9.17.1	CAL Mode Description.....	68
9.17.2	Self Refresh Entry, Exit Timing with CAL.....	71
9.17.3	Power Down Entry, Exit Timing with CAL.....	71
9.18	CRC.....	73
9.18.1	CRC Polynomial and logic equation.....	73
9.18.2	CRC data bit mapping for x16 device with BL8.....	74
9.18.3	Write CRC for x16 device.....	75
9.18.4	CRC Error Handling.....	75
9.18.5	CRC Frame format with BC4.....	76
9.18.6	Simultaneous DM and CRC Functionality.....	78
9.18.7	Simultaneous MPR Write, Per DRAM Addressability and CRC Functionality.....	78
9.19	Command Address Parity (CA Parity).....	79
9.19.1	CA Parity Error Log Readout.....	85
9.20	Control Gear-down Mode.....	86
9.21	DDR4 Key Core Timing.....	88
9.22	Programmable Preamble.....	91
9.22.1	Write Preamble.....	91
9.22.2	Read Preamble.....	93
9.22.3	Read Preamble Training.....	93
9.23	Postamble.....	94
9.23.1	Read Postamble.....	94
9.23.2	Write Postamble.....	94
9.24	ACTIVATE Command.....	95
9.25	Precharge Command.....	95
9.26	Read Operation.....	95
9.26.1	READ Timing Definitions.....	95
9.26.1.1	READ Timing; Clock to Data Strobe relationship.....	97
9.26.1.2	READ Timing; Data Strobe to Data relationship.....	98
9.26.1.3	tLZ(DQS), tLZ(DQ), tHZ(DQS), tHZ(DQ) Calculation.....	99
9.26.1.4	tRPRE Calculation.....	101
9.26.1.5	tRPST Calculation.....	102
9.26.2	READ Burst Operation.....	103
9.26.3	Burst Read Operation Followed by a Precharge.....	114
9.26.4	Burst Read Operation with Read DBI (Data Bus Inversion).....	116
9.26.5	Burst Read Operation with Command/Address Parity.....	117
9.26.6	Read to Write with Write CRC.....	118
9.26.7	Read to Read with CS to CA Latency.....	119
9.27	Write Operation.....	120
9.27.1	Write Timing Parameters.....	120
9.27.2	Write Data Mask.....	121
9.27.3	tWPRE Calculation.....	122
9.27.4	tWPST Calculation.....	123
9.27.5	Write Burst Operation.....	124
9.27.6	Read and Write Command Interval.....	138
9.27.7	Write Timing Violations.....	139
9.27.7.1	Motivation.....	139
9.27.7.2	Data Setup and Hold Offset Violations.....	139
9.27.7.3	Strobe and Strobe to Clock Timing Violations.....	139
9.28	Refresh Command.....	140
9.29	Self Refresh Operation.....	141



9.29.1	Low Power Auto Self Refresh.....	143
9.30	Power Down Mode.....	145
9.30.1	Power-Down Entry and Exit.....	145
9.30.2	Power-Down Clarifications.....	150
9.30.3	Power Down Entry and Exit timing during Command/Address Parity Mode is Enable.....	151
9.31	Connectivity Test Mode	151
9.31.1	Introduction	151
9.31.2	Pin Mapping in Connectivity Test (CT) Mode.....	152
9.31.3	Logic Equations.....	153
9.31.3.1	Min Term Equations.....	153
9.31.3.2	Output equations for x16 devices.....	153
9.31.4	Input level and Timing Requirement for Connectivity Test (CT) Mode.....	154
9.31.5	Connectivity Test (CT) Mode Input Levels	155
9.31.5.1	Input Levels for RESET_n.....	156
9.31.5.2	Input Levels for ALERT_n.....	156
9.32	Post Package Repair (hPPR).....	157
9.32.1	Hard Fail Row Address Repair (WRA Case).....	158
9.32.2	Hard Fail Row Address Repair (WR Case).....	159
9.32.3	Hard Fail Row Address Repair MR bits and timing diagram.....	159
9.32.4	Programming hPPR and sPPR support in MPR0 page2.....	161
9.32.5	Required Timing Parameters for hPPR.....	161
9.33	Soft Post Package Repair (sPPR)	161
9.33.1	Soft Repair of a Fail Row Address.....	162
10.	On-Die Termination.....	164
10.1	ODT Mode Register and ODT State Table	164
10.1.1	ODT Temperature and Voltage sensitivity	166
10.2	Synchronous ODT Mode.....	167
10.2.1	ODT Latency and Posted ODT.....	167
10.2.2	Timing Parameters	168
10.2.3	ODT during Reads	169
10.3	Dynamic ODT	170
10.3.1	Functional Description	170
10.3.2	ODT Timing Diagrams.....	171
10.4	Asynchronous ODT mode.....	172
10.5	ODT buffer disabled mode for Power down	173
10.6	ODT Timing Definitions	174
10.6.1	Test Load for ODT Timings	174
10.6.2	ODT Timing Definitions	174
11.	Absolute Maximum Ratings	177
12.	AC and DC Operating Conditions.....	177
12.1	AC and DC Logic input levels for single-ended signals.....	177
12.2	AC and DC Input Measurement Levels: VREF Tolerances	178
12.3	AC and DC Logic Input Levels for Differential Signals	179
12.3.1	Differential signal definition.....	179
12.3.2	Differential swing requirements for clock (CK_t - CK_c).....	179
12.3.3	Single-ended requirements for differential signals (CK_t, CK_c).....	180
12.3.4	Address, Command and Control Overshoot and Undershoot specifications	181
12.3.5	Clock Overshoot and Undershoot Specifications	182
12.3.6	Data, Strobe and Mask Overshoot and Undershoot Specifications	183
12.4	Slew Rate Definitions.....	184
12.4.1	Slew Rate Definitions for Differential Input Signals (CK).....	184
12.4.2	Slew Rate Definition for Single-ended Input Signals (CMD/ADD)	185
12.5	Differential Input Cross Point Voltage (CK).....	185
12.6	CMOS rail to rail Input Levels	186
12.6.1	CMOS rail to rail Input Levels for RESET_n.....	186



12.7	AC and DC Logic Input Levels for DQS Signals	187
12.7.1	Differential signal definition.....	187
12.7.2	Differential swing requirements for DQS (DQS_t - DQS_c).....	187
12.7.3	Peak voltage calculation method	187
12.7.4	Differential Input Cross Point Voltage (DQS)	188
12.7.5	Differential Input Slew Rate Definition.....	189
13.	AC and DC Output Measurement Levels	190
13.1	Output Driver DC Electrical Characteristics	190
13.1.1	Alert_n Output Drive Characteristic	192
13.1.2	Output Driver Characteristic of Connectivity Test (CT) Mode.....	193
13.2	Single-ended AC & DC Output Levels	193
13.3	Differential AC & DC Output Levels	194
13.4	Single-ended Output Slew Rate.....	194
13.5	Differential Output Slew Rate.....	195
13.6	Single-ended AC and DC Output Levels of Connectivity Test Mode	196
13.7	Test Load for Connectivity Test Mode Timing.....	196
14.	Speed Bins.....	197
14.1	Speed Bin Table Note.....	203
15.	IDD and IDDQ Specification Parameters and Test Conditions	204
15.1	IDD, IPP and IDDQ Measurement Conditions	204
15.2	IDD, IDDQ & IPP Specifications.....	220
16.	Input/Output Capacitance	222
17.	Electrical Characteristics and AC Timing.....	223
17.1	Reference Load for AC Timing and Output Slew Rate.....	223
17.2	tREFI.....	223
17.2.1	Operating Temperature Condition	224
17.3	Clock Specification.....	224
17.4	Timing Parameters by Speed Grade.....	225
17.5	Rounding Algorithms.....	239
17.6	The DQ input receiver compliance mask for voltage and timing	241
17.7	Command, Control, and Address Setup, Hold, and Derating.....	245
17.8	Function Matrix	247
18.	Package Specification.....	249
19.	Revision History	250



1. General Description

The W664GG6RB is a 4G bits DDR4 SDRAM, organized as 256Mb × 16 I/Os. This device achieves high speed transfer rates up to 3200 MT/s (DDR4-3200) for various applications. The W664GG6RB is sorted into the following speed grades: -06, -07, -08, 06I, 07I, 08I, 06J, 07J and 08J.

The -06 ,06I and 06J speed grades are compliant to the DDR4-3200 (22-22-22) specification (The 06I industrial grade which is guaranteed to support $-40^{\circ}\text{C} \leq \text{T}_{\text{CASE}} \leq 95^{\circ}\text{C}$, the 06J industrial plus grade which is guaranteed to support $-40^{\circ}\text{C} \leq \text{T}_{\text{CASE}} \leq 105^{\circ}\text{C}$).

The -07 ,07I and 07J speed grades are compliant to the DDR4-2666 (19-19-19) specification (The 07I industrial grade which is guaranteed to support $-40^{\circ}\text{C} \leq \text{T}_{\text{CASE}} \leq 95^{\circ}\text{C}$, the 07J industrial plus grade which is guaranteed to support $-40^{\circ}\text{C} \leq \text{T}_{\text{CASE}} \leq 105^{\circ}\text{C}$).

The -08, 08I and 08J speed grades are compliant to the DDR4-2400 (17-17-17) specification (The 08I industrial grade which is guaranteed to support $-40^{\circ}\text{C} \leq \text{T}_{\text{CASE}} \leq 95^{\circ}\text{C}$, the 08J industrial plus grade which is guaranteed to support $-40^{\circ}\text{C} \leq \text{T}_{\text{CASE}} \leq 105^{\circ}\text{C}$).

The W664GG6RB is designed to comply with the following key DDR4 SDRAM features such as Temperature controlled Refresh, Low Power Auto Self Refresh, Fine Granularity Refresh, Data Bus Inversion, Command/Address Latency, Command/Address Parity, Data bus Write CRC, Control Gear-Down, Programmable data strobe preamble, DQ VREF Training, Per DRAM Addressability, Connectivity Test, ZQ calibration, On Die Termination and Asynchronous Reset. All of the control and address inputs are synchronized with a pair of externally supplied differential clocks. Inputs are latched at the cross point of differential clocks (CK_t rising and CK_c falling). All I/Os are synchronized with a differential DQS_t-DQS-c pair in a source synchronous fashion.



2. Features

- Power Supply: VDD, VDDQ = 1.2V \pm 60mV
- Power Supply: VPP = 2.5V -125mV / +250mV
- Clock rate: up to 1600 MHz
- Data rate: up to 3200 Mbps
- 8 bit prefetch architecture
- Multipurpose register READ and WRITE capability
- Write Leveling
- Programmable data strobe preambles
- Data strobe preamble training
- Command/Address Latency (CAL)
- Data Bus Inversion (DBI) for data bus
- Output driver calibration
- On-Die Termination (ODT)
- Configuration:

Configuration		256 Mb x16
Bank Address	# of Bank Groups	2
	BG Address	BG0
	Bank Address in a BG	BA0~BA1
Row Address		A0~A14
Column Address		A0~A9
Page size		2KB

- Self refresh mode
- Self refresh abort
- Low-Power Auto Self Refresh (LPASR)
- Temperature Controlled Refresh (TCR)
- Fine granularity refresh
- Command/Address (CA) Parity
- Data bus write cyclic redundancy check (CRC)
- Per DRAM addressability
- Gear-down mode
- Post package repair (hPPR) mode
- Soft post package repair (sPPR) mode
- Rx CTLE Control
- Connectivity Test Mode
- Interface: POD12
- Support package:
VFBGA 96 Ball (7.5x13 mm² with 1.0 mm thickness),
using lead free materials with RoHS compliant
- Operating Temperature Range:
0°C \leq TCASE \leq 95°C
-40°C \leq TCASE \leq 95°C
-40°C \leq TCASE \leq 105°C

3. Order Information

PART NUMBER	SPEED GRADE	OPERATING TEMPERATURE
W664GG6RB-06	DDR4-3200 (22-22-22)	0°C \leq TCASE \leq 95°C
W664GG6RB06I	DDR4-3200 (22-22-22)	-40°C \leq TCASE \leq 95°C
W664GG6RB06J	DDR4-3200 (22-22-22)	-40°C \leq TCASE \leq 105°C
W664GG6RB-07	DDR4-2666 (19-19-19)	0°C \leq TCASE \leq 95°C
W664GG6RB07I	DDR4-2666 (19-19-19)	-40°C \leq TCASE \leq 95°C
W664GG6RB07J	DDR4-2666 (19-19-19)	-40°C \leq TCASE \leq 105°C
W664GG6RB-08	DDR4-2400 (17-17-17)	0°C \leq TCASE \leq 95°C
W664GG6RB08I	DDR4-2400 (17-17-17)	-40°C \leq TCASE \leq 95°C
W664GG6RB08J	DDR4-2400 (17-17-17)	-40°C \leq TCASE \leq 105°C



4. Key Parameters

Speed Bin			DDR4-2400		DDR4-2666		DDR4-3200		Unit	
CL-nRCD-nRP			17-17-17		19-19-19		22-22-22			
Part Number Extension			-08/08/08J		-07/07/07J		-06/06/06J			
Parameter	Symbol		Min.	Max.	Min.	Max.	Min.	Max.		
Maximum operating frequency using maximum allowed settings for Sup_CL and Sup_CWL		fCKMAX	-	1200	-	1333	-	1600	MHz	
Internal read command to first data		tAA	14.16 <i>(13.75)*1,2</i>	18.00	14.25 <i>(13.75)*1,2</i>	18.00	13.75	18.00	nS	
Internal read command to first data with read DBI enabled		tAA_DBI	tAA(min) + 3nCK	tAA(max) + 3nCK	tAA(min) + 3nCK	tAA(max) + 3nCK	tAA(min) + 4nCK	tAA(max) + 4nCK	nS	
ACT to internal read or write delay time		tRCD	14.16 <i>(13.75)*1,2</i>	-	14.25 <i>(13.75)*1,2</i>	-	13.75	-	nS	
PRE command period		tRP	14.16 <i>(13.75)*1,2</i>	-	14.25 <i>(13.75)*1,2</i>	-	13.75	-	nS	
ACT to PRE command period		tRAS	32	9 * tREFI	32	9 * tREFI	32	9 * tREFI	nS	
ACT to ACT or REF command period		tRC	46.16 <i>(45.75)*1,2</i>	-	46.25 <i>(45.75)*1,2</i>	-	45.75	-	nS	
	Normal	Read DBI								
CWL = 9	CL = 10	CL = 12	tCK(AVG)	1.5	1.6	1.5	1.6	1.5	1.6	nS
CWL = 9,11	CL = 11	CL = 13	tCK(AVG)	1.25	< 1.5	1.25	< 1.5	1.25	< 1.5	nS
				<i>(Option)*1,2</i>		<i>(Option)*1,2</i>				
CWL = 10,12	CL = 12	CL = 14	tCK(AVG)	1.25	< 1.5	1.25	< 1.5	1.25	< 1.5	nS
				<i>(Option)*1,2</i>		<i>(Option)*1,2</i>				
CWL = 10,12	CL = 13	CL = 15	tCK(AVG)	1.071	< 1.25	1.071	< 1.25	1.071	< 1.25	nS
				<i>(Option)*1,2</i>		<i>(Option)*1,2</i>				
CWL = 11,14	CL = 14	CL = 16	tCK(AVG)	1.071	< 1.25	1.071	< 1.25	1.071	< 1.25	nS
				<i>(Option)*1,2</i>		<i>(Option)*1,2</i>				
CWL = 11,14	CL = 15	CL = 18	tCK(AVG)	0.937	< 1.071	0.937	< 1.071	0.937	< 1.071	nS
				<i>(Option)*1,2</i>		<i>(Option)*1,2</i>				
CWL = 12,16	CL = 16	CL = 19	tCK(AVG)	0.937	< 1.071	0.937	< 1.071	0.937	< 1.071	nS
				<i>(Option)*1,2</i>		<i>(Option)*1,2</i>				
CWL = 12,16	CL = 17	CL = 20	tCK(AVG)	0.833	< 0.937	0.833	< 0.937	0.833	< 0.937	nS
				<i>(Option)*1,2</i>		<i>(Option)*1,2</i>				
CWL = 12,16	CL = 18	CL = 21	tCK(AVG)	0.833	< 0.937	0.833	< 0.937	0.833	< 0.937	nS
				<i>(Option)*1,2</i>		<i>(Option)*1,2</i>				
CWL = 14,18	CL = 19	CL = 22	tCK(AVG)	Reserved		0.75	< 0.833	0.75	< 0.833	nS
				Reserved		<i>(Option)*1,2</i>				
CWL = 14,18	CL = 20	CL = 23	tCK(AVG)	Reserved		0.75	< 0.833	0.75	< 0.833	nS
				Reserved		<i>(Option)*1,2</i>				
CWL = 16,20	CL = 21	CL = 25	tCK(AVG)	Reserved		Reserved		0.682	< 0.75	nS
				Reserved		<i>(Option)*1,2</i>				
	CL = 22	CL = 26	tCK(AVG)	Reserved		Reserved		0.682	< 0.75	nS
CWL = 16,20	CL = 24	CL = 28	tCK(AVG)	Reserved		Reserved		0.682	< 0.75	nS
				Reserved		<i>(Option)*1,2</i>				
CWL = 16,20	CL = 22	CL = 26	tCK(AVG)	Reserved		Reserved		0.625	< 0.682	nS
				Reserved		<i>(Option)*1,2</i>				
CWL = 16,20	CL = 24	CL = 28	tCK(AVG)	Reserved		Reserved		0.625	< 0.682	nS
				Reserved		<i>(Option)*1,2</i>				
Supported CL Settings		Sup_CL	10, (11), 12, (13), 14, (15), 16, 17, 18		10, (11), 12, (13), 14, (15), 16, (17), 18, 19, 20		10, 11, 12, 13, 14, 15, 16, 17, 18, 19, 20, 21, 22, 24		nCK	
Supported CL Settings with read DBI		Sup_CLD	12, (13), 14, (15), 16, (18), 19, 20, 21		12, (13), 14, (15), 16, (18), 19, (20), 21, 22, 23		12, 13, 14, 15, 16, 18, 19, 20, 21, 22, 23, 25, 26, 28		nCK	
Supported CWL Settings		Sup_CWL	9, 10, 11, 12, 14, 16		9, 10, 11, 12, 14, 16, 18		9, 10, 11, 12, 14, 16, 18, 20		nCK	
Average periodic refresh Interval	-40°C ≤ TCASE ≤ 85°C	tREFI	-	7.8	-	7.8	-	7.8	µS	
	0°C ≤ TCASE ≤ 85°C		-	7.8	-	7.8	-	7.8	µS	
	85°C < TCASE ≤ 95°C		-	3.9	-	3.9	-	3.9	µS	
	95°C < TCASE ≤ 105°C		-	1.95	-	1.95	-	1.95	µS	

(Field value contents in blue font or parentheses are optional AC parameter and Read non DBI, Read DBI CL setting.)

Notes:

- “Optional” settings allow certain devices in the industry to support this setting. Any combination of the “optional” CL’s is supported. The associated “optional” tAA, tRCD, tRP, and tRC values must be adjusted based upon the CL combination supported.
- Parameters apply from tCK(avg)min to tCK(avg)max at all standard JEDEC clock period values as stated in the Speed Bin Tables.



5. Ball Assignment

5.1 DDR4 SDRAM x16 Package VFBGA 96 Ball Assignment

	1	2	3	4	5	6	7	8	9	
A	VDDQ	VSSQ	DQU0				DQSU_c	VSSQ	VDDQ	A
B	VPP	VSS	VDD				DQSU_t	DQU1	VDD	B
C	VDDQ	DQU4	DQU2				DQU3	DQU5	VSSQ	C
D	VDD	VSSQ	DQU6				DQU7	VSSQ	VDDQ	D
E	VSS	DMU_n/ DBIU_n	VSSQ				DML_n DBIL_n	VSSQ	VSS	E
F	VSSQ	VDDQ	DQSL_c				DQL1	VDDQ	ZQ	F
G	VDDQ	DQL0	DQSL_t				VDD	VSS	VDDQ	G
H	VSSQ	DQL4	DQL2				DQL3	DQL5	VSSQ	H
J	VDD	VDDQ	DQL6				DQL7	VDDQ	VDD	J
K	VSS	CKE	ODT				CK_t	CK_c	VSS	K
L	VDD	WE_n/ A14	ACT_n				CS_n	RAS_n/ A16	VDD	L
M	VREFCA	BG0	A10/ AP				A12/ BC_n	CAS_n/ A15	VSS	M
N	VSS	BA0	A4				A3	BA1	TEN	N
P	RESET_n	A6	A0				A1	A5	ALERT_n	P
R	VDD	A8	A2				A9	A7	VPP	R
T	VSS	A11	PAR				NC	A13	VDD	T



6. Ball Description

Name	Type	Function
CK_t, CK_c	Input	Clock: CK_t and CK_c are differential clock inputs. All address and control input signals are sampled on the crossing of the positive edge of CK_t and negative edge of CK_c.
CKE	Input	Clock Enable: CKE HIGH activates, and CKE Low deactivates, internal clock signals and device input buffers and output drivers. Taking CKE Low provides Precharge Power-Down and Self-Refresh operation (all banks idle), or Active Power-Down (row Active in any bank). CKE is synchronous for Self-Refresh exit. After VREFCA and Internal DQ VREF have become stable during the power on and initialization sequence, they must be maintained during all operations (including Self-Refresh). CKE must be maintained high throughout read and write accesses. Input buffers, excluding CK_t, CK_c, ODT and CKE are disabled during power-down. Input buffers, excluding CKE, are disabled during Self-Refresh.
CS_n	Input	Chip Select: All commands are masked when CS_n is registered HIGH. CS_n provides for external Rank selection on systems with multiple Ranks. CS_n is considered part of the command code.
ODT	Input	On-Die Termination: ODT (registered HIGH) enables RTT_NOM termination resistance internal to the DDR4 SDRAM. When enabled, ODT is only applied to each DQ, DQSU_t, DQSU_c, DQSL_t, DQSL_c, DMU_n, and DML_n signal. The ODT pin will be ignored if MR1 is programmed to disable RTT_NOM.
ACT_n	Input	Activation Command Input: ACT_n defines the Activation command being entered along with CS_n. The input into RAS_n/A16, CAS_n/A15 and WE_n/A14 will be considered as Row Address A16, A15 and A14.
RAS_n/A16 CAS_n/A15 WE_n/A14	Input	Command Inputs: RAS_n/A16, CAS_n/A15 and WE_n/A14 (along with CS_n) define the command being entered. Those pins have multi-function. For example, for activation with ACT_n Low, those are Addressing like A16, A15 and A14 but for non-activation command with ACT_n High, those are Command pins for Read, Write and other command defined in command truth table.
DMU_n/DBIU_n, DML_n/DBIL_n	Input/ Output	Input Data Mask and Data Bus Inversion: DMU_n / DML_n are input mask signal for write data. Input data is masked when DMU_n / DML_n is sampled LOW coincident with that input data during a Write access. DMU_n / DML_n are sampled on both edges of DQSU / DQSL. DM is muxed with DBI function by Mode Register A10, A11, A12 setting in MR5. DMU_n/DBIU_n is associated with DQU0-DQU7; DML_n/DBIL_n is associated with DQL0-DQL7. DBIU_n / DBIL_n are input/output identifying whether to store/output the true or inverted data. If DBIU_n / DBIL_n LOW, the data will be stored/output after inversion inside the DDR4 SDRAM and not inverted if DBIU_n / DBIL_n HIGH.
BG0	Input	Bank Group Input: BG0 define to which bank group an Active, Read, Write or Precharge command is being applied. BG0 also determines which mode register is to be accessed during a MRS cycle.
BA0 - BA1	Input	Bank Address Inputs: BA0 - BA1 define to which bank an Active, Read, Write or Precharge command is being applied. Bank address also determines which mode register is to be accessed during a MRS cycle.
A0 - A16	Input	Address Inputs: Provide the row address for ACTIVATE Commands and the column address for Read/Write commands to select one location out of the memory array in the respective bank. (A10/AP, A12/BC_n, RAS_n/A16, CAS_n/A15 and WE_n/A14 have additional functions, see other rows. The address inputs also provide the op-code during Mode Register Set commands.
A10 / AP	Input	Auto Precharge: A10 is sampled during Read/Write commands to determine whether Auto precharge should be performed to the accessed bank after the Read/Write operation. (HIGH: Auto precharge; LOW: no Auto precharge). A10 is sampled during a Precharge command to determine whether the Precharge applies to one bank (A10 LOW) or all banks (A10 HIGH). If only one bank is to be precharged, the bank is selected by bank addresses.
A12 / BC_n	Input	Burst Chop: A12 / BC_n is sampled during Read and Write commands to determine if burst chop (on-the-fly) will be performed. (HIGH, no burst chop; LOW: burst chopped). See command truth table for details.
RESET_n	Input	Active Low Asynchronous Reset: Reset is active when RESET_n is LOW, and inactive when RESET_n is HIGH. RESET_n must be HIGH during normal operation. RESET_n is a CMOS rail to rail signal with DC high and low at 80% and 20% of VDD,
DQL0-DQL7 DQU0-DQU7	Input/ Output	Data Input/ Output: Bi-directional data bus. If CRC is enabled via Mode register then CRC code is added at the end of Data Burst. DQL0-DQL3 may indicate the internal VREF level during test via Mode Register Setting MR4 A4 = High. During this mode, RTT value should be set to Hi-Z.



Name	Type	Function
DQSU_t, DQSU_c, DQSL_t, DQSL_c	Input/ Output	Data Strobe: Output with read data, input with write data. Edge-aligned with read data, centered in write data. DQSL corresponds to the data on DQL0-DQL7; DQSU corresponds to the data on DQU0-DQU7. The data strobe DQSL_t and DQSU_t are paired with differential signals DQSL_c and DQSU_c, respectively, to provide differential pair signaling to the system during reads and writes. DDR4 SDRAM supports differential data strobe only and does not support single-ended.
PAR	Input	Command and Address Parity Input: DDR4 Supports Even Parity check in DRAMs with MR setting. Once it's enabled via Register in MR5, then DRAM calculates Parity with ACT_n, RAS_n/A16, CAS_n/A15, WE_n/A14, BG0, BA0-BA1 and A16-A0. Command and address inputs shall have parity check performed when commands are latched via the rising edge of CK_t and when CS_n is low.
ALERT_n	Input/ Output	Alert: It has multi functions such as CRC error flag, Command and Address Parity error flag as Output signal. If there is error in CRC, then Alert_n goes LOW for the period time interval and goes back HIGH. If there is error in Command Address Parity Check, then ALERT_n goes LOW for relatively long period until ongoing DRAM internal recovery transaction to complete. During Connectivity Test mode, this pin works as input. Using this signal or not is dependent on system. In case of not connected as Signal, ALERT_n Pin must be bounded to VDD on board.
TEN	Input	Connectivity Test Mode Enable: HIGH in this pin will enable Connectivity Test Mode operation along with other pins. It is a CMOS rail to rail signal with AC high and low at 80% and 20% of VDD. Using this signal or not is dependent on system. This pin may be DRAM internally pulled low through a weak pull-down resistor to VSS.
NC		No Connect: No internal electrical connection is present.
VDDQ	Supply	DQ Power Supply: 1.2 V \pm 0.06 V
VSSQ	Supply	DQ Ground
VDD	Supply	Power Supply: 1.2 V \pm 0.06 V
VSS	Supply	Ground
VPP	Supply	DRAM Activating Power Supply: 2.5V (2.375V min, 2.75V max)
VREFCA	Supply	Reference voltage for CA
ZQ	Supply	Reference Pin for ZQ calibration

Note: Input only pins (BG0, BA0-BA1, A0-A16, ACT_n, RAS_n/A16, CAS_n/A15, WE_n/A14, CS_n, CKE, ODT, and RESET_n) do not supply termination.



7. Block Diagram

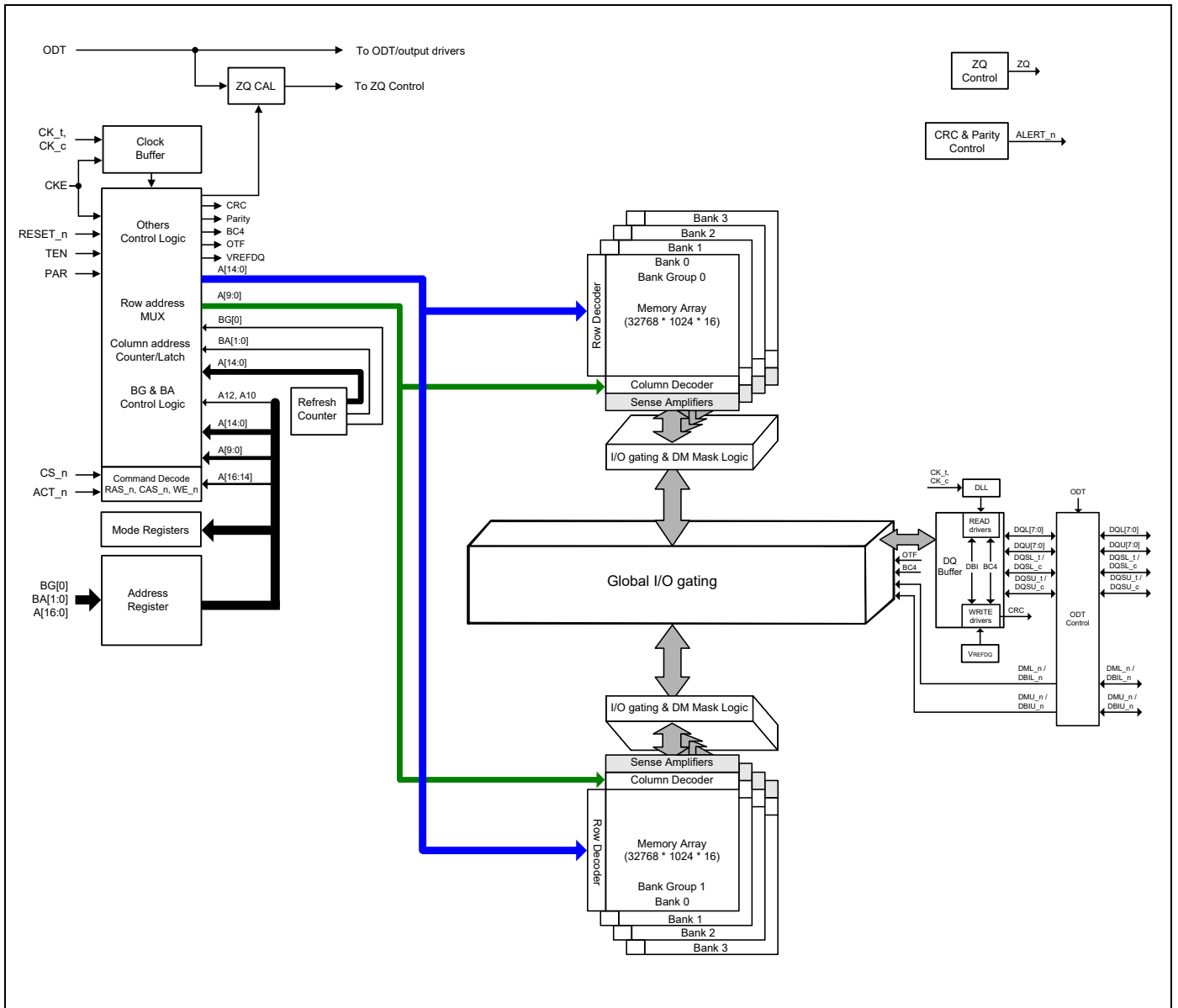



8. Functional Description

The following sections provide detailed information covering device reset and initialization, register definition, command descriptions, and device operation.

8.1 Simplified DDR4 State Diagram

This simplified State Diagram is intended to provide an overview of the possible state transitions and the commands to control them. In particular, situations involving more than on bank, the enabling or disabling of on-die termination, and some other events are not captured in full detail.

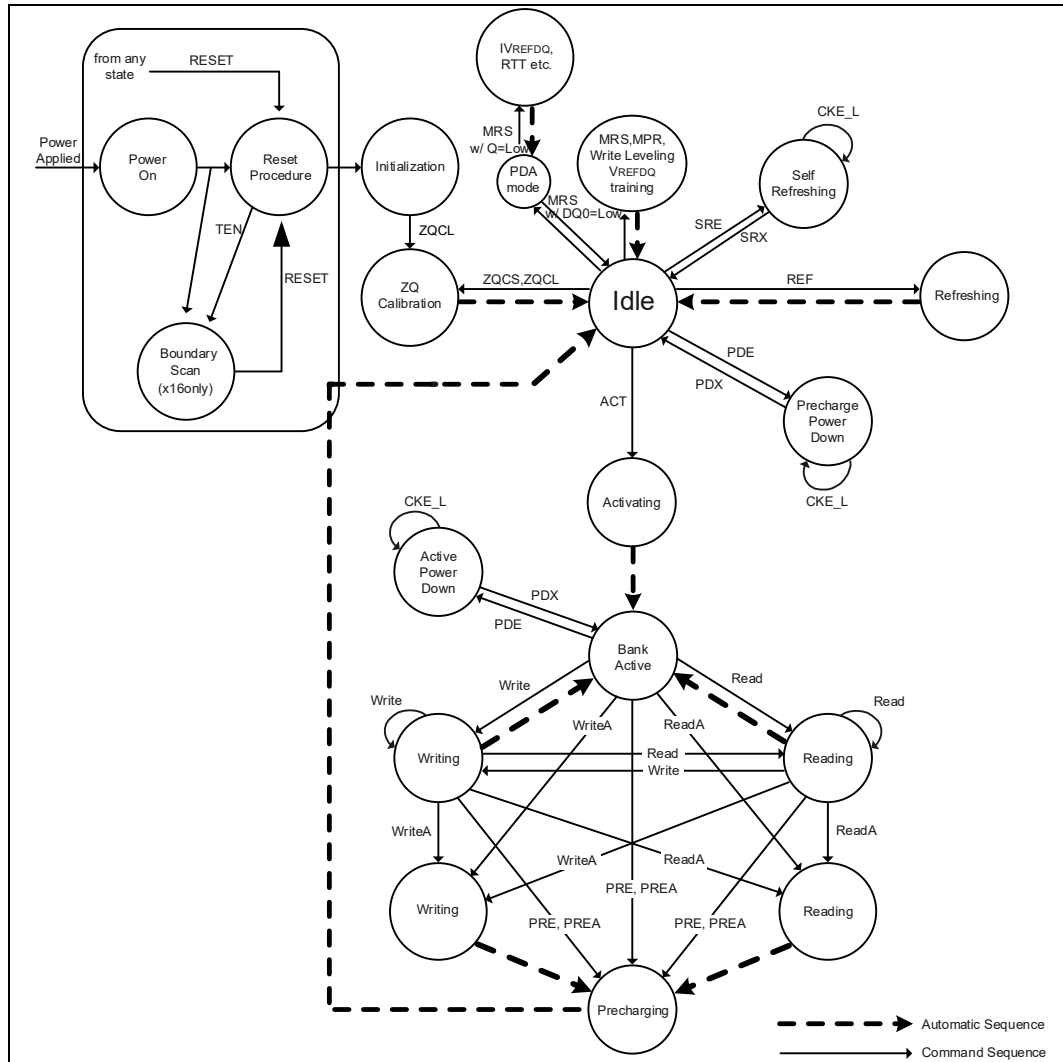

Abbreviation	Function	Abbreviation	Function	Abbreviation	Function
ACT	Activate	Read	RD, RDS4, RDS8	PDE	Enter Power-down
PRE	Precharge	Read A	RDA, RDAS4, RDAS8	PDX	Exit Power-down
PREA	Precharge All	Write	WR, WRS4, WRS8 with/without CRC	SRE	Self-Refresh entry
MRS	Mode Register Set	Write A	WRA, WRAS4, WRAS8 with/without CRC	SRX	Self-Refresh exit
REF	Refresh, Fine granularity Refresh	RESET_n	Start RESET procedure	MPR	Multi-Purpose Register
TEN	Boundary Scan Mode Enable				



8.2 Basic Functionality

The W664GG6RB DDR4 SDRAM is a high-speed dynamic random-access memory internally configured as eight-banks, 2 bank group with 4 banks for each bank group.

The DDR4 SDRAM uses an 8n prefetch architecture to achieve high-speed operation. The 8n prefetch architecture is combined with an interface designed to transfer two data words per clock cycle at the I/O pins. A single read or write operation for the DDR4 SDRAM consists of a single 8n-bit wide, four clock data transfer at the internal DRAM core and eight corresponding n-bit wide, one-half clock cycle data transfers at the I/O pins.

Read and write operation to the DDR4 SDRAM are burst oriented, start at a selected location, and continue for a burst length of eight or a "chopped" burst of four in a programmed sequence. Operation begins with the registration of an ACTIVATE Command, which is then followed by a Read or Write command. The address bits registered coincident with the ACTIVATE Command are used to select the bank and row to be activated (BG0 select the bank group; BA0-BA1 select the bank; A0-A14 select the row; refer to configuration table of section 2 "Features" for specific requirements). The address bits registered coincident with the Read or Write command are used to select the starting column location for the burst operation, determine if the auto precharge command is to be issued (via A10), and select BC4 or BL8 mode "on the fly" (via A12) if enabled in the mode register.

Prior to normal operation, the DDR4 SDRAM must be powered up and initialized in a predefined manner.

The following sections provide detailed information covering device reset and initialization, register definition, command descriptions, and device operation.

8.3 RESET and Initialization Procedure

For power-up and reset initialization, in order to prevent DRAM from functioning improperly default values for the following MR settings need to be defined.

Gear-down mode (MR3 A[3]): 0 = 1/2 Rate

Per DRAM Addressability (MR3 A[4]): 0 = Disable

CS to Command/Address Latency (MR4 A[8:6]): 000 = Disable

CA Parity Latency Mode (MR5 A[2:0]): 000 = Disable

Hard Post Package Repair mode (MR4 A[13]): 0 = Disable

Soft Post Package Repair mode (MR4 A[5]): 0 = Disable



8.3.1 Power-up Initialization Sequence

The following sequence is required for POWER UP and Initialization and is shown in Figure 1.

1. Apply power (RESET_n and TEN are recommended to be maintained below $0.2 \times V_{DD}$; all other inputs may be undefined). RESET_n needs to be maintained below $0.2 \times V_{DD}$ for minimum 200 μ S with stable power and TEN needs to be maintained below $0.2 \times V_{DD}$ for minimum 700 μ S with stable power. CKE is pulled "Low" any time before RESET_n being de-asserted (min. time 10nS). The power voltage ramp time between 300mV to V_{DD} min must be no greater than 200mS; and during the ramp, $V_{DD} \geq V_{DDQ}$ and $(V_{DD}-V_{DDQ}) < 0.3V$. V_{PP} must ramp at the same time or earlier than V_{DD} and V_{PP} must be equal to or higher than V_{DD} at all times.
 - V_{DD} and V_{DDQ} are driven from a single power converter output, AND
 - The voltage levels on all pins other than $V_{DD}, V_{DDQ}, V_{SS}, V_{SSQ}$ must be less than or equal to V_{DDQ} and V_{DD} on one side and must be larger than or equal to V_{SSQ} and V_{SS} on the other side. In addition, V_{TT} is limited to 0.76V max once power ramp is finished, AND
 - V_{REFCA} tracks $V_{DD}/2$.

or

 - Apply V_{DD} without any slope reversal before or at the same time as V_{DDQ}
 - Apply V_{DDQ} without any slope reversal before or at the same time as V_{TT} & V_{REFCA} .
 - Apply V_{PP} without any slope reversal before or at the same time as V_{DD} .
 - The voltage levels on all pins other than $V_{DD}, V_{DDQ}, V_{SS}, V_{SSQ}$ must be less than or equal to V_{DDQ} and V_{DD} on one side and must be larger than or equal to V_{SSQ} and V_{SS} on the other side.
2. After RESET_n is de-asserted, wait for another 500 μ S until CKE becomes active. During this time, the DRAM will start internal initialization; this will be done independently of external clocks.
3. Clocks (CK_t, CK_c) need to be started and stabilized for at least 10nS or 5tCK (which is larger) before CKE goes active. Since CKE is a synchronous signal, the corresponding setup time to clock (tIS) must be met. Also, a Deselect command must be registered (with tIS set up time to clock) at clock edge Td. Once the CKE registered "High" after Reset, CKE needs to be continuously registered "High" until the initialization sequence is finished, including expiration of tDLLK and tZQinit.
4. The DDR4 SDRAM keeps its on-die termination in high-impedance state as long as RESET_n is asserted. Further, the SDRAM keeps its on-die termination in high impedance state after RESET_n deassertion until CKE is registered HIGH. The ODT input signal may be in undefined state until tIS before CKE is registered HIGH. When CKE is registered HIGH, the ODT input signal may be statically held at either LOW or HIGH. If RTT_NOM is to be enabled in MR1 the ODT input signal must be statically held LOW. In all cases, the ODT input signal remains static until the power up initialization sequence is finished, including the expiration of tDLLK and tZQinit.
5. After CKE is being registered high, wait minimum of Reset CKE Exit time, tXPR, before issuing the first MRS command to load mode register. (tXPR=Max(tXS, 5nCK)]
6. Issue MRS Command to load MR3 with all application settings (To issue MRS command to MR3, provide "Low" to BG0, "High" to BA1, BA0)
7. Issue MRS command to load MR6 with all application settings (To issue MRS command to MR6, provide "Low" to BA0, "High" to BG0, BA1)
8. Issue MRS command to load MR5 with all application settings (To issue MRS command to MR5, provide "Low" to BA1, "High" to BG0, BA0)
9. Issue MRS command to load MR4 with all application settings (To issue MRS command to MR4, provide "Low" to BA1, BA0, "High" to BG0)
10. Issue MRS command to load MR2 with all application settings (To issue MRS command to MR2, provide "Low" to BG0, BA0, "High" to BA1)
11. Issue MRS command to load MR1 with all application settings (To issue MRS command to MR1, provide "Low" to BG0, BA1, "High" to BA0)
12. Issue MRS command to load MR0 with all application settings (To issue MRS command to MR0, provide "Low" to BG0, BA1, BA0)
13. Issue ZQCL command to starting ZQ calibration
14. Wait for both tDLLK and tZQinit completed
15. The DDR4 SDRAM is now ready for read/Write training (include VREF training and Write leveling).

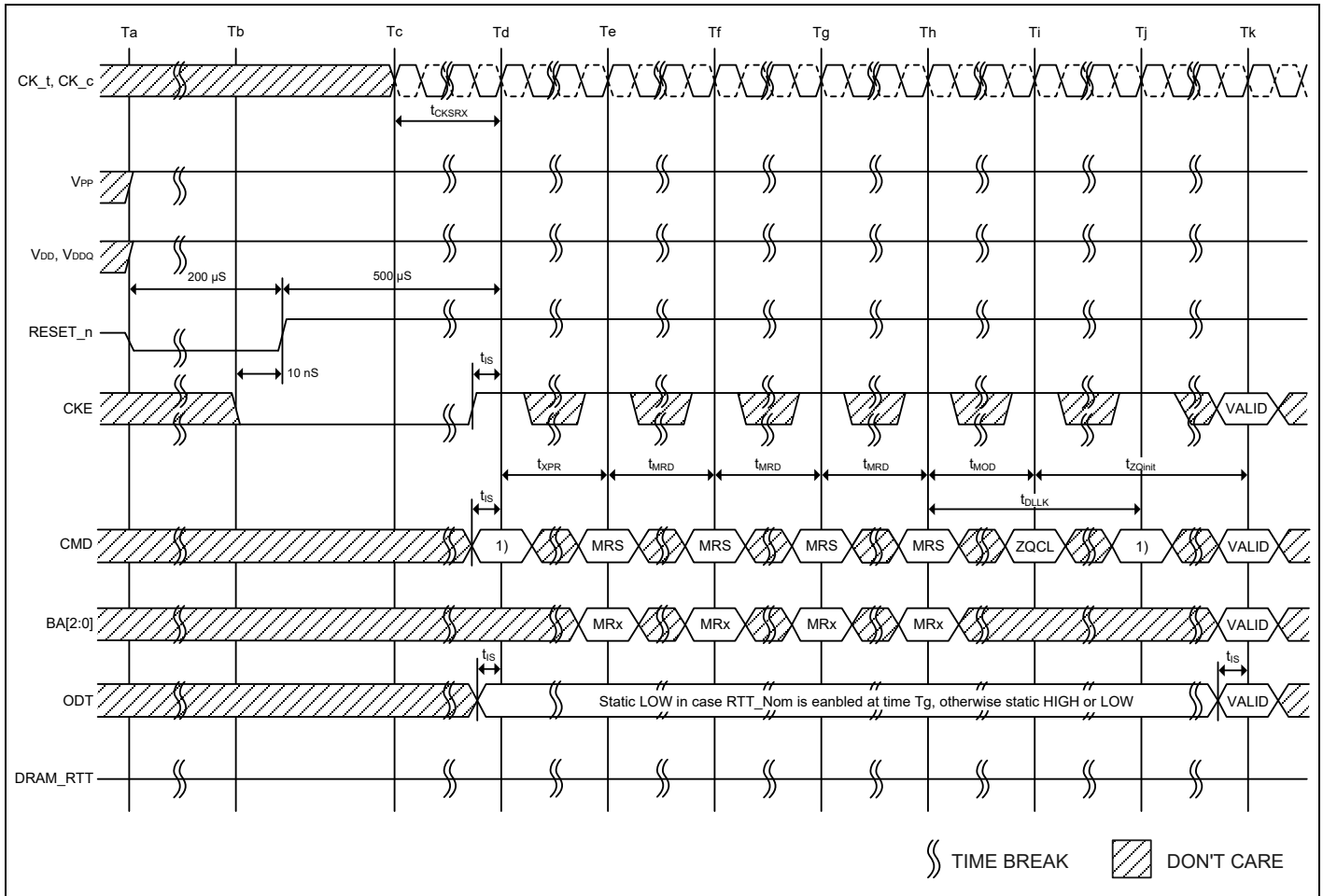

Notes:

1. From time point 'Td' until 'Tk', DES commands must be applied between MRS and ZQCL commands.
2. MRS Commands must be issued to all Mode Registers that have defined settings.

Figure 1 – RESET_n and Initialization Sequence at Power-on Ramping

8.3.2 VDD Slew rate at Power-up Initialization Sequence

VDD Slew Rate

Symbol	Min	Max	Units
VDD_sl*1	0.004	600	V/mS*2
VDD_on*1		200	mS*3

Notes:

1. Measurement made between 300mV and 80% VDD minimum.
2. 20 MHz band limited measurement.
3. Maximum time to ramp VDD from 300mV to VDD minimum.

8.3.3 Reset Initialization with Stable Power

The following sequence is required for RESET at no power interruption initialization as shown in Figure 2.

1. Asserted RESET_n below 0.2 * VDD anytime when reset is needed (all other inputs may be undefined). RESET_n needs to be maintained for minimum tPW_RESET. CKE is pulled “LOW” before RESET_n being de-asserted (min. time 10 nS).
2. Follow steps 2 to 10 in “Power-up Initialization Sequence”.
3. The Reset sequence is now completed, DDR4 SDRAM is ready for Read/Write training (include VREF training and Write leveling)

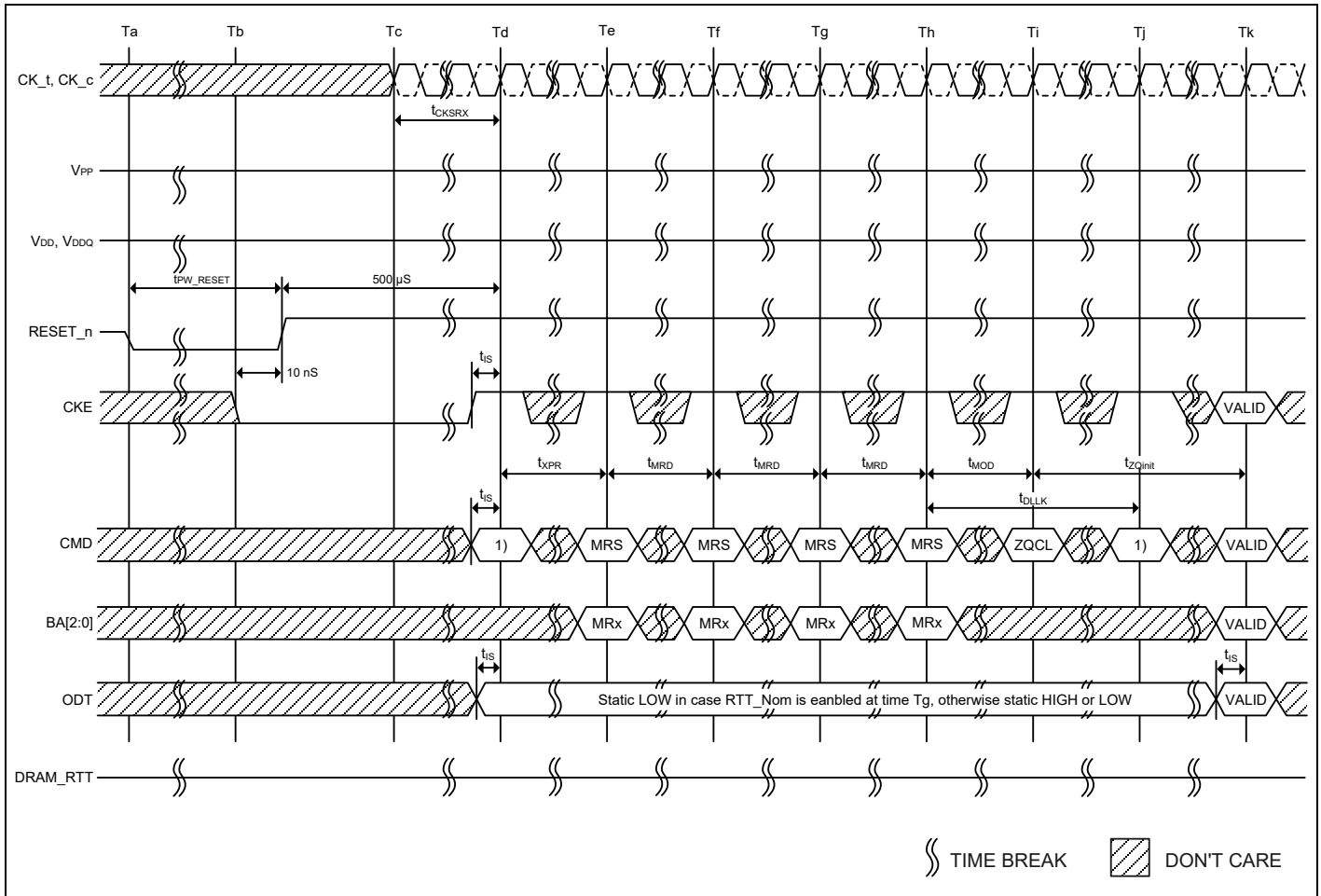

Notes:

1. From time point 'Td' until 'Tk', DES commands must be applied between MRS and ZQCL commands.
2. MRS Commands must be issued to all Mode Registers that have defined settings.

Figure 2 – Reset Procedure at Power Stable

8.4 Mode Register Definition

8.4.1 Programming the mode registers

For application flexibility, various functions, features, and modes are programmable in seven Mode Registers, provided by the DDR4 SDRAM, as user defined variables and they must be programmed via a Mode Register Set (MRS) command. The mode registers are divided into various fields depending on the functionality and/or modes. As not all the Mode Registers (MR#) have default values defined, contents of Mode Registers must be initialized and/or re-initialized, i.e., written, after power up and/or reset for proper operation. Also, the contents of the Mode Registers can be altered by re-executing the MRS command during normal operation. When programming the mode registers, even if the user chooses to modify only a sub-set of the MRS fields, all address fields within the accessed mode register must be redefined when the MRS command is issued. MRS command and DLL Reset do not affect array contents, which means these commands can be executed any time after power-up without affecting the array contents. MRS Commands can be issued only when DRAM is at idle state. The mode register set command cycle time, t_{MRD} is required to complete the write operation to the mode register and is the minimum time required between two MRS commands shown in Figure 3.

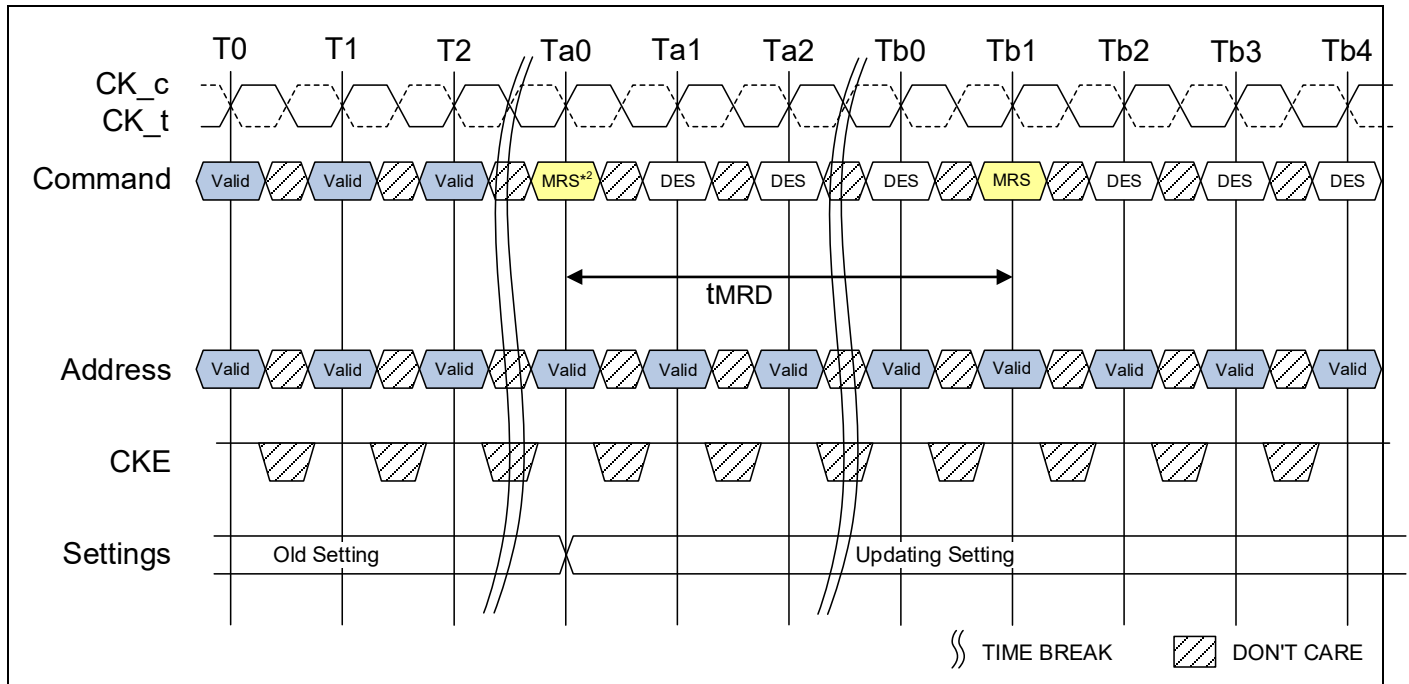
**Notes:**

1. This timing diagram shows CA Parity Latency mode is "Disable" case.
2. List of MRS commands exception that do not apply to tMRD
 - Gear-down mode
 - CA Parity Latency mode
 - CS to Command/Address Latency mode
 - Per DRAM Addressability mode
 - VREFDQ training Value, VREFDQ Training mode and VREFDQ training Range

Figure 3 – tMRD Timing

Some of the Mode Register setting affect to address/command/control input functionality. These cases, next MRS command can be allowed when the function updating by current MRS command completed.

The MRS commands which do not apply tMRD timing to next MRS command are listed in note 2 of Figure 3. These MRS command input cases have unique MR setting procedure, so refer to individual function description.

The most MRS command to Non-MRS command delay, tMOD, is required for the DRAM to update the features, and is the minimum time required from an MRS command to a non-MRS command excluding DES shown in Figure 4.

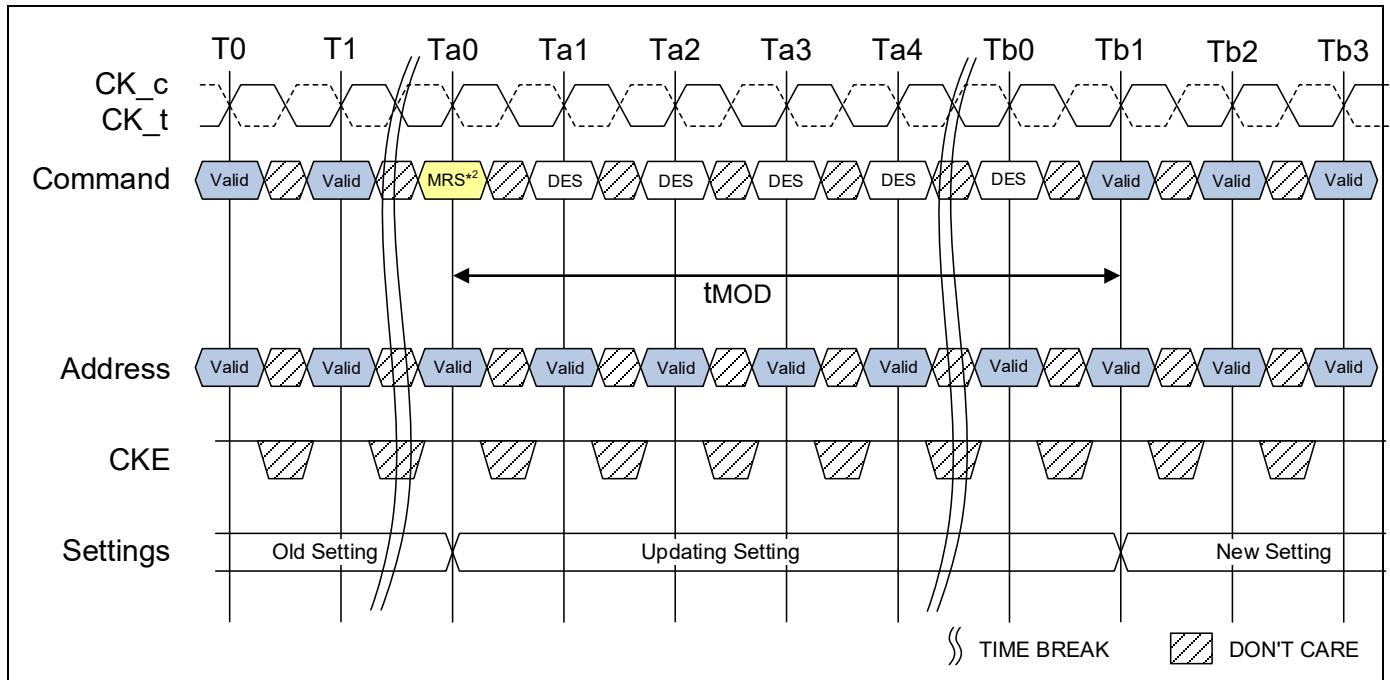

Notes:

1. This timing diagram shows CA Parity Latency mode is "Disable" case.
2. List of MRS commands exception that do not apply to tMOD
 - DLL Enable, DLL Reset
 - VREFDQ training Value, internal VREF Monitor, VREFDQ Training mode and VREFDQ training Range
 - Gear-down mode
 - Per DRAM addressability mode
 - CA Parity mode

Figure 4 – tMOD Timing

Some of the Mode Register setting cases, function updating takes longer than tMOD. The MRS commands which do not apply tMOD timing to next valid command excluding DES is listed in note 2 of Figure 4. These MRS command input cases have unique MR setting procedure, so refer to individual function description.

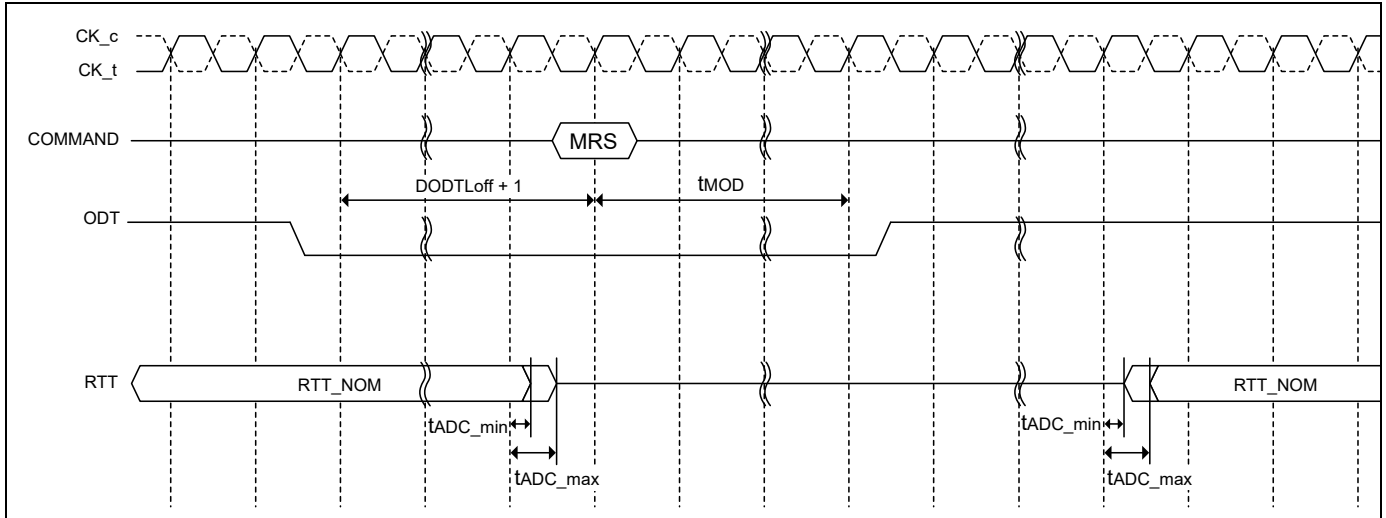

Notes:

1. This timing diagram shows CA Parity Latency mode is "Disable" case.
2. When an MRS command mentioned in this note affects RTT_NOM turn on timings, RTT_NOM turn off timings and RTT_NOM value, this means the MR register value changes. The ODT signal should set to be low for at least DODTLoff +1 clock before their affecting MRS command is issued and remain low until tMOD expires. The following MR registers affects RTT_NOM turn on timings, RTT_NOM turn off timings and RTT_NOM value and it requires ODT to be low when an MRS command change the MR register value. If there are no changes the MR register value that corresponds to commands mentioned in this note, then the ODT signal is not required to be low.
 - DLL control for precharge power down
 - Additive latency and CAS read latency
 - DLL enable and disable
 - CAS write latency
 - CA Parity mode
 - Gear-Down mode
 - RTT_NOM

Figure 5 – ODT Status at MRS affecting ODT turn-on/off timing

The mode register contents can be changed using the same command and timing requirements during normal operation as long as the DRAM is in idle state, i.e., all banks are in the precharged state with tRP satisfied, all data bursts are completed and CKE is high prior to writing into the mode register. For MRS command, If RTT_Nom function is intended to change (enable to disable and vice versa) or already enabled in DRAM MR, ODT signal must be registered Low ensuring RTT_NOM is in an off state prior to MRS command affecting RTT_NOM turn-on and off timing. Refer to note2 of Figure 5 for this type of MRS. The ODT signal may be registered high after tMOD has expired. ODT signal is a don't care during MRS command if DRAM RTT_Nom function is disabled in the mode register prior to and after an MRS command.



Table 2 – CAS Latency

A12	A6	A5	A4	A2	CAS Latency
0	0	0	0	0	9
0	0	0	0	1	10
0	0	0	1	0	11
0	0	0	1	1	12
0	0	1	0	0	13
0	0	1	0	1	14
0	0	1	1	0	15
0	0	1	1	1	16
0	1	0	0	0	18
0	1	0	0	1	20
0	1	0	1	0	22
0	1	0	1	1	24
0	1	1	0	0	23
0	1	1	0	1	17
0	1	1	1	0	19
0	1	1	1	1	21
1	0	0	0	0	25
1	0	0	0	1	26
1	0	0	1	0	Reserved
1	0	0	1	1	28
1	0	1	0	0	29
1	0	1	0	1	30
1	0	1	1	0	31
1	0	1	1	1	32
1	1	0	0	0	Reserved



MR1

Address	Operating Mode	Description
BG1	RFU	0 = must be programmed to 0 during MRS
BG0, BA1:BA0	MR Select	000 = MR0 100 = MR4 001 = MR1 101 = MR5 010 = MR2 110 = MR6 011 = MR3 111 = RCW*3
A13, A6, A5	Rx CTLE control*5	000 = Vendor Optimized Setting (default) 001 = Vendor defined 010 = Vendor defined 011 = Vendor defined 100 = Vendor defined 101 = Vendor defined 110 = Vendor defined 111 = Vendor defined
A12	Qoff*1	0 = Output buffer enabled 1 = Output buffer disabled
A11	TDQS enable*4	0 = Disable 1 = Enable
A10, A9, A8	RTT_NOM	(See Table 3)
A7	Write Leveling Enable	0 = Disable 1 = Enable
A4, A3	Additive Latency	00 = 0(AL disabled) 10 = CL-2 01 = CL-1 11 = Reserved
A2, A1	Output Driver Impedance Control	(See Table 4)
A0	DLL Enable	0 = Disable*2 1 = Enable

Notes:

1. Outputs disabled - DQs, DQS_ts, DQS_cs.
2. States reversed to "0 as Disable" with respect to DDR4.
3. Reserved for Register control word setting. DRAM ignores MR command with BG0, BA1; BA0=111 and doesn't respond. When RFU MR code setting is inputted, DRAM operation is not defined.
4. TDQS function is only available for x8 DRAM. The x16 DRAM must disable the TDQS function via mode register A11 = 0 in MR1.
5. For further information about Rx CTLE control please contact sales representative.

Table 3 – RTT_NOM

A10	A9	A8	RTT_NOM
0	0	0	RTT_NOM Disable
0	0	1	RZQ/4
0	1	0	RZQ/2
0	1	1	RZQ/6
1	0	0	RZQ/1
1	0	1	RZQ/5
1	1	0	RZQ/3
1	1	1	RAQ/7

Table 4 – Output Driver Impedance Control

A2	A1	Output Driver Impedance Control
0	0	RZQ/7
0	1	RZQ/5
1	0	Reserved
1	1	Reserved



MR2

Address	Operating Mode	Description
BG1	RFU	0 = must be programmed to 0 during MRS
BG0, BA1:BA0	MR Select	000 = MR0 100 = MR4 001 = MR1 101 = MR5 010 = MR2 110 = MR6 011 = MR3 111 = RCW*1
A13	RFU	0 = must be programmed to 0 during MRS
A12	Write CRC	0 = Disable 1 = Enable
A11, A10:A9	RTT_WR	(See Table 5)
A8, A2	RFU	0 = must be programmed to 0 during MRS
A7:A6	Low Power Array Self Refresh (LP ASR)	00 = Manual Mode (Normal Operating Temperature Range) 01 = Manual Mode (Reduced Operating Temperature Range) 10 = Manual Mode (Extended Operating Temperature Range) 11 = ASR Mode (Auto Self Refresh)
A5:A3	CAS Write Latency (CWL)	(See Table 6)
A1:A0	RFU	0 = must be programmed to 0 during MRS

Note:

- Reserved for Register control word setting. DRAM ignores MR command with BG0, BA1; BA0=111 and doesn't respond. When RFU MR code setting is inputted, DRAM operation is not defined.

Table 5 – RTT_WR

A11	A10	A9	RTT_WR
0	0	0	Dynamic ODT Off
0	0	1	RZQ/2
0	1	0	RZQ/1
0	1	1	Hi-Z
1	0	0	RZQ/3
1	0	1	Reserved
1	1	0	Reserved
1	1	1	Reserved

Table 6 – CWL (CAS Write Latency)

A5	A4	A3	CWL	Operating Data Rate in MT/s for 1tCK Write Preamble		Operating Data Rate in MT/s for 2tCK Write Preamble*1	
				1st Set	2nd Set	1st Set	2nd Set
0	0	0	9	1600			
0	0	1	10	1866			
0	1	0	11	2133	1600		
0	1	1	12	2400	1866		
1	0	0	14	2666	2133	2400	
1	0	1	16	3200	2400	2666	2400
1	1	0	18		2666	3200	2666
1	1	1	20		3200		3200

Note:

- The 2tCK Write Preamble is valid for DDR4-2400/2666/3200 Speed Grade. For the 2nd Set of 2tCK Write Preamble, no additional CWL is needed.



MR3

Address	Operating Mode	Description
BG1	RFU	0 = must be programmed to 0 during MRS
BG0, BA1:BA0	MR Select	000 = MR0 100 = MR4 001 = MR1 101 = MR5 010 = MR2 110 = MR6 011 = MR3 111 = RCW* ¹
A13	RFU	0 = must be programmed to 0 during MRS
A12:A11	MPR Read Format	00 = Serial 10 = Staggered 01 = Parallel 11 = Reserved
A10:A9	Write CMD Latency when CRC and DM are enabled	(See Table 8)
A8:A6	Fine Granularity Refresh Mode	(See Table 7)
A5	Temperature sensor readout	0 = Disable 1 = Enable
A4	Per DRAM Addressability	0 = Disable 1 = Enable
A3	Gear-down Mode	0 = 1/2 Rate 1 = 1/4 Rate
A2	MPR Operation	0 = Normal 1 = Dataflow from/to MPR
A1:A0	MPR page Selection	00 = Page0 10 = Page2 01 = Page1 11 = Page3 (See Table 9)

Note:

- Reserved for Register control word setting. DRAM ignores MR command with BG0, BA1; BA0=111 and doesn't respond. When RFU MR code setting is inputted, DRAM operation is not defined.

Table 7 – Fine Granularity Refresh Mode

A8	A7	A6	Fine Granularity Refresh
0	0	0	Normal (Fixed 1x)
0	0	1	Fixed 2x
0	1	0	Fixed 4x
0	1	1	Reserved
1	0	0	Reserved
1	0	1	Enable on the fly 2x
1	1	0	Enable on the fly 4x
1	1	1	Reserved

Table 8 – MR3 A[10:9] Write Command Latency when CRC and DM are both enabled

A10	A9	CRC+DM Write Command Latency	Operating Data Rate
0	0	4nCK	1600
0	1	5nCK	1866, 2133, 2400, 2666
1	0	6nCK	3200
1	1	RFU	RFU

Notes:

- Write Command latency when CRC and DM are both enabled.
- At less than or equal to 1600 then 4nCK; neither 5nCK nor 6nCK.
- At greater than 1600 and less than or equal to 2666 then 5nCK; neither 4nCK nor 6nCK.
- At greater than 2666 and less than or equal to 3200 then 6nCK; neither 4nCK nor 5nCK.
- Write Command Latency provides the extra time required when completing a WRITE burst when write CRC and DM are enabled.



Table 9 – MPR Data Format

MPR page0 (Training Pattern)

Address	MPR Location	[7]	[6]	[5]	[4]	[3]	[2]	[1]	[0]	Note
BA1:BA0	00 = MPR0	0	1	0	1	0	1	0	1	Read/ Write (default value)
	01 = MPR1	0	0	1	1	0	0	1	1	
	10 = MPR2	0	0	0	0	1	1	1	1	
	11 = MPR3	0	0	0	0	0	0	0	0	

MPR page1 (CA Parity Error Log)

Address	MPR Location	[7]	[6]	[5]	[4]	[3]	[2]	[1]	[0]	Note
BA1:BA0	00 = MPR0	A[7]	A[6]	A[5]	A[4]	A[3]	A[2]	A[1]	A[0]	Read- only
	01 = MPR1	CAS_n/ A15	WE_n/ A14	A[13]	A[12]	A[11]	A[10]	A[9]	A[8]	
	10 = MPR2	PAR	ACT_n	BG[1]	BG[0]	BA[1]	BA[0]	A[17]*2	RAS_n /A16	
	11 = MPR3	CRC Error Status	CA Parity Error Status	CA Parity Latency*4			C[2]*3	C[1]*3	C[0]*3	
			MR5.A[2]	MR5.A[1]	MR5.A[0]					

Notes

- MPR used for CA parity error log readout is enabled by setting A[2] in MR3.
- For x16 device BG[1] is not used, MPR2[5] should be treated as don't care. The 4Gb DRAM A[17] is not used, MPR2[1] should be treated as don't care.
- If a device is used in monolithic application, where C[2:0] are not used, then MPR3[2:0] should be treated as don't care.
- MPR3 bit 3~5 (CA parity latency) reflects the latest programmed CA parity latency values.



MPR page2 (MRS Readout)

Address	MPR Location	[7]	[6]	[5]	[4]	[3]	[2]	[1]	[0]	Note	
BA1:BA0	00=MPR0	hPPR	sPPR	RTT_WR	Temperature Sensor Status		CRC Write Enable	Rtt_WR		Read-only	
		-	-	MR2	-	-	MR2	MR2			
		-	-	A11	-	-	A12	A10	A9		
	01=MPR1	VREF DQ training range	VREF DQ training Value						Gear-down Enable		
		MR6	MR6						MR3		
		A6	A5	A4	A3	A2	A1	A0	A3		
	10=MPR2	CAS Latency				CAS Write Latency					
		MR0				MR2					
		A6	A5	A4	A2	A12	A5	A4	A3		
	11=MPR3	Rtt_Nom			Rtt_Park			Driver Impedance			
		MR1			MR5			MR1			
		A10	A9	A8	A8	A7	A6	A2	A1		

MR3 bit A5 for Temperature Sensor Readout

MR3 bit A5=1: DRAM updates the temperature sensor status to MPR Page 2 (MPR0 A[4:3]). Temperature data is guaranteed by the DRAM to be no more than 32mS old at the time of MPR Read of the Temperature Sensor Status bits.

MR3 bit A5=0: DRAM disables updates to the temperature sensor status in MPR Page 2 (MPR0 A[4:3])

MPR0 bit A4	MPR0 bit A3	Refresh Rate Range
0	0	Sub 1X refresh (> tREFI)
0	1	1X refresh rate(= tREFI)
1	0	2X refresh rate(1/2* tREFI)
1	1	Reserved

MPR page3

Address	MPR Location	[7]	[6]	[5]	[4]	[3]	[2]	[1]	[0]	Note
BA1:BA0	00 = MPR0	don't care	don't care	don't care	don't care	don't care	don't care	don't care	don't care	Read-only
	01 = MPR1	don't care	don't care	don't care	don't care	don't care	don't care	don't care	don't care	
	10 = MPR2	don't care	don't care	don't care	don't care	don't care	don't care	don't care	don't care	
	11 = MPR3	don't care	don't care	don't care	don't care	MAC	MAC	MAC	MAC	



MR4

Address	Operating Mode	Description
BG1	RFU	0 = must be programmed to 0 during MRS
BG0, BA1:BA0	MR Select	000 = MR0 100 = MR4 001 = MR1 101 = MR5 010 = MR2 110 = MR6 011 = MR3 111 = RCW* ¹
A13	hPPR	0 = Disable 1 = Enable
A12	Write Preamble	0 = 1nCK 1 = 2nCK
A11	Read Preamble	0 = 1nCK 1 = 2nCK
A10	Read Preamble Training Mode	0 = Disable 1 = Enable
A9	Self Refresh Abort	0 = Disable 1 = Enable
A8:A6	CS to CMD/ADDR Latency Mode (cycles)	000 = Disable 100 = 6 001 = 3 101 = 8 010 = 4 110 = Reserved 011 = 5 111 = Reserved (See Table 10)
A5	sPPR	0 = Disable 1 = Enable
A4	Internal VREF Monitor	0 = Disable 1 = Enable
A3	Temperature Controlled Refresh Mode	0 = Disable 1 = Enable
A2	Temperature Controlled Refresh Range	0 = Normal 1 = Extended
A1	RFU	0 = must be programmed to 0 during MRS
A0	RFU	0 = must be programmed to 0 during MRS

Note:

- Reserved for Register control word setting. DRAM ignores MR command with BG0, BA1; BA0=111 and doesn't respond. When RFU MR code setting is inputted, DRAM operation is not defined.

Table 10 – CS to CMD / ADDR Latency Mode Setting

A8	A7	A6	CAL
0	0	0	Disable
0	0	1	3
0	1	0	4
0	1	1	5
1	0	0	6
1	0	1	8
1	1	0	Reserved
1	1	1	Reserved



MR5

Address	Operating Mode	Description
BG1	RFU	0 = must be programmed to 0 during MRS
BG0, BA1:BA0	MR Select	000 = MR0 100 = MR4 001 = MR1 101 = MR5 010 = MR2 110 = MR6 011 = MR3 111 = RCW*1
A13	RFU	0 = must be programmed to 0 during MRS
A12	Read DBI	0 = Disable 1 = Enable
A11	Write DBI	0 = Disable 1 = Enable
A10	Data Mask	0 = Disable 1 = Enable
A9	CA Parity Persistent Error	0 = Disable 1 = Enable
A8:A6	RTT_PARK	(See Table 11)
A5	ODT Input Buffer during Power Down mode	0 = ODT input buffer is activated 1 = ODT input buffer is deactivated
A4	CA Parity Error Status	0 = Clear 1 = Error
A3	CRC Error Clear	0 = Clear 1 = Error
A2:A0	CA Parity Latency Mode	(See Table 12)

Notes

- Reserved for Register control word setting. DRAM ignores MR command with BG0, BA1; BA0=111 and doesn't respond. When RFU MR code setting is inputted, DRAM operation is not defined.
- When RTT_NOM Disable is set in MR1, A5 of MR5 will be ignored.

Table 11 – RTT_PARK

A8	A7	A6	RTT_PARK
0	0	0	RTT_PARK Disable
0	0	1	RZQ/4
0	1	0	RZQ/2
0	1	1	RZQ/6
1	0	0	RZQ/1
1	0	1	RZQ/5
1	1	0	RZQ/3
1	1	1	RZQ/7

Table 12 – CA Parity Latency Mode

A2	A1	A0	PL	Speed Bin
0	0	0	Disable	
0	0	1	4	1600, 1866, 2133
0	1	0	5	2400, 2666
0	1	1	6	3200
1	0	0	Reserved	
1	0	1	Reserved	
1	1	0	Reserved	
1	1	1	Reserved	

Note: Parity Latency must be programmed according to timing parameters by speed grades table.



MR6

Address	Operating Mode	Description
BG1	RFU	0 = must be programmed to 0 during MRS
BG0, BA1:BA0	MR Select	000 = MR0 001 = MR1 010 = MR2 011 = MR3 100 = MR4 101 = MR5 110 = MR6 111 = RCW*1
A13	RFU	0 = must be programmed to 0 during MRS
A12:A10	tCCD_L	(See Table 13)
A9, A8	RFU	0 = must be programmed to 0 during MRS
A7	VREFDQ Training Enable	0 = Disable (Normal Operation Mode) 1 = Enable (Training Mode)
A6	VREFDQ Training Range	(See Table 14)
A5:A0	VREFDQ Training Value	(See Table 15)

Note:

- Reserved for Register control word setting. DRAM ignores MR command with BG0, BA1; BA0=111 and doesn't respond.

Table 13 – tCCD_L and tDLLK

A12	A11	A10	tCCD_L min (nCK)*1	tDLLK min (nCK)*1	Note
0	0	0	4	597	Data rate ≤ 1333Mbps
0	0	1	5		1333Mbps ≤ Data rate ≤ 1866Mbps (1600/1866Mbps)
0	1	0	6	768	1866Mbps ≤ Data rate ≤ 2400Mbps (2133/2400Mbps)
0	1	1	7	1024	2400Mbps ≤ Data rate ≤ 2666Mbps (2666Mbps)
1	0	0	8		2666Mbps ≤ Data rate ≤ 3200Mbps (3200Mbps)
1	0	1	Reserved		
1	1	0			
1	1	1			

Note:

- tCCD_L/tDLLK should be programmed according to the value defined in AC parameter table per operating frequency.



Table 14 – VREFDQ Training Range

A6	VREFDQ Range
0	Range 1
1	Range 2

Table 15 – VREFDQ Training Values

A5:A0	Range1	Range2	A5:A0	Range1	Range2
00 0000	60.00%	45.00%	01 1010	76.90%	61.90%
00 0001	60.65%	45.65%	01 1011	77.55%	62.55%
00 0010	61.30%	46.30%	01 1100	78.20%	63.20%
00 0011	61.95%	46.95%	01 1101	78.85%	63.85%
00 0100	62.60%	47.60%	01 1110	79.50%	64.50%
00 0101	63.25%	48.25%	01 1111	80.15%	65.15%
00 0110	63.90%	48.90%	10 0000	80.80%	65.80%
00 0111	64.55%	49.55%	10 0001	81.45%	66.45%
00 1000	65.20%	50.20%	10 0010	82.10%	67.10%
00 1001	65.85%	50.85%	10 0011	82.75%	67.75%
00 1010	66.50%	51.50%	10 0100	83.40%	68.40%
00 1011	67.15%	52.15%	10 0101	84.05%	69.05%
00 1100	67.80%	52.80%	10 0110	84.70%	69.70%
00 1101	68.45%	53.45%	10 0111	85.35%	70.35%
00 1110	69.10%	54.10%	10 1000	86.00%	71.00%
00 1111	69.75%	54.75%	10 1001	86.65%	71.65%
01 0000	70.40%	55.40%	10 1010	87.30%	72.30%
01 0001	71.05%	56.05%	10 1011	87.95%	72.95%
01 0010	71.70%	56.70%	10 1100	88.60%	73.60%
01 0011	72.35%	57.35%	10 1101	89.25%	74.25%
01 0100	73.00%	58.00%	10 1110	89.90%	74.90%
01 0101	73.65%	58.65%	10 1111	90.55%	75.55%
01 0110	74.30%	59.30%	11 0000	91.20%	76.20%
01 0111	74.95%	59.95%	11 0001	91.85%	76.85%
01 1000	75.60%	60.60%	11 0010	92.50%	77.50%
01 1001	76.25%	61.25%	11 0011 to 11 1111	Reserved	Reserved

MR7 DRAM: Ignore

The DDR4 SDRAM shall ignore any access to MR7 for all DDR4 SDRAM. Any bit setting within MR7 may not take any effect in the DDR4 SDRAM.



9. Command Description and Operation

9.1 Command Truth Table

(a) Note 1, 2, 3 and 4 apply to the entire Command truth table

(b) Note 5 applies to all Read/Write commands.

[BG=Bank Group Address, BA=Bank Address, RA=Row Address, CA=Column Address, BC_n=Burst Chop, X=Don't Care, V=Valid].

Table 16 – Command Truth Table

FUNCTION	Abbr.	CKE		CS_n	ACT_n	RAS_n/ A16	CAS_n/ A15	WE_n/ A14	BG0	BA0- BA1	A12/ BC_n	A13, A11	A10/ AP	A0- A9	Notes
		Previous Cycle	Current Cycle												
Mode Register Set	MRS	H	H	L	H	L	L	L	BG	BA	OP Code				
Refresh	REF	H	H	L	H	L	L	H	V	V	V	V	V	V	
Self Refresh Entry	SRE	H	L	L	H	L	L	H	V	V	V	V	V	V	7,9
Self Refresh Exit	SRX	L	H	H	X	X	X	X	X	X	X	X	X	X	7,8,9, 10
				L	H	H	H	H	H	V	V	V	V	V	
Single Bank Precharge	PRE	H	H	L	H	L	H	L	BG	BA	V	V	L	V	
Precharge all Banks	PREA	H	H	L	H	L	H	L	V	V	V	V	H	V	
RFU	RFU	H	H	L	H	L	H	H	RFU						
Bank Activate	ACT	H	H	L	L	Row Address (RA)			BG	BA	Row Address (RA)				
Write (Fixed BL8 or BC4)	WR	H	H	L	H	H	L	L	BG	BA	V	V	L	CA	
Write (BC4, on the Fly)	WRS4	H	H	L	H	H	L	L	BG	BA	L	V	L	CA	
Write (BL8, on the Fly)	WRS8	H	H	L	H	H	L	L	BG	BA	H	V	L	CA	
Write with Auto Precharge (Fixed BL8 or BC4)	WRA	H	H	L	H	H	L	L	BG	BA	V	V	H	CA	
Write with Auto Precharge (BC4, on the Fly)	WRAS4	H	H	L	H	H	L	L	BG	BA	L	V	H	CA	
Write with Auto Precharge (BL8, on the Fly)	WRAS8	H	H	L	H	H	L	L	BG	BA	H	V	H	CA	
Read (Fixed BL8 or BC4)	RD	H	H	L	H	H	L	H	BG	BA	V	V	L	CA	
Read (BC4, on the Fly)	RDS4	H	H	L	H	H	L	H	BG	BA	L	V	L	CA	
Read (BL8, on the Fly)	RDS8	H	H	L	H	H	L	H	BG	BA	H	V	L	CA	
Read with Auto Precharge (Fixed BL8 or BC4)	RDA	H	H	L	H	H	L	H	BG	BA	V	V	H	CA	
Read with Auto Precharge (BC4, on the Fly)	RDAS4	H	H	L	H	H	L	H	BG	BA	L	V	H	CA	
Read with Auto Precharge (BL8, on the Fly)	RDAS8	H	H	L	H	H	L	H	BG	BA	H	V	H	CA	
No Operation	NOP	H	H	L	H	H	H	H	V	V	V	V	V	V	10
Device Deselected	DES	H	H	H	X	X	X	X	X	X	X	X	X	X	
Power Down Entry	PDE	H	L	H	X	X	X	X	X	X	X	X	X	X	6
Power Down Exit	PDX	L	H	H	X	X	X	X	X	X	X	X	X	X	6
ZQ Calibration Long	ZQCL	H	H	L	H	H	H	L	V	V	V	V	H	V	
ZQ Calibration Short	ZQCS	H	H	L	H	H	H	L	V	V	V	V	L	V	

**Notes:**

1. All DDR4 SDRAM commands are defined by states of CS_n, ACT_n, RAS_n/A16, CAS_n/A15, WE_n/A14 and CKE at the rising edge of the clock. The MSB of BG, BA, RA and CA are device density and configuration dependent. When ACT_n = H; pins RAS_n/A16, CAS_n/A15, and WE_n/A14 are used as command pins RAS_n, CAS_n, and WE_n respectively. When ACT_n = L; pins RAS_n/A16, CAS_n/A15, and WE_n/A14 are used as address pins A16, A15, and A14 respectively
2. RESET_n is Low enable command which will be used only for asynchronous reset so must be maintained HIGH during any function.
3. Bank Group addresses (BG) and Bank addresses (BA) determine which bank within a bank group to be operated upon. For MRS commands the BG and BA selects the specific Mode Register location.
4. "V" means "H or L (but a defined logic level)" and "X" means either "defined or undefined (like floating) logic level".
5. Burst reads or writes cannot be terminated or interrupted and Fixed/on-the-Fly BL will be defined by MRS.
6. The Power-Down Mode does not perform any refresh operation.
7. The state of ODT does not affect the states described in this table. The ODT function is not available during Self Refresh.
8. Controller guarantees self refresh exit to be synchronous.
9. VPP and VREF (VREFCA) must be maintained during Self Refresh operation.
10. The No Operation command should be only used in cases when the DDR4 SDRAM is in Gear-Down Mode.
11. Refer to the CKE Truth Table for more detail with CKE transition.



9.2 CKE Truth Table

Table 17 – CKE Truth Table

Current State* ²	CKE		Command (N)* ³ RAS_n, CAS_n, WE_n, CS_n	Action (N)* ³	Notes
	Previous Cycle* ¹ (N-1)	Current Cycle* ¹ (N)			
Power Down	L	L	X	Maintain Power-Down	13, 14
	L	H	DESELECT	Power Down Exit	11, 13
Self Refresh	L	L	X	Maintain Self Refresh	14, 15
	L	H	DESELECT	Self Refresh Exit	8, 15
Bank(s) Active	H	L	DESELECT	Active Power Down Entry	11, 12, 13
Reading	H	L	DESELECT	Power Down Entry	11, 12, 13, 16
Writing	H	L	DESELECT	Power Down Entry	11, 12, 13, 16
Precharging	H	L	DESELECT	Power Down Entry	11, 12, 13, 16
Refreshing	H	L	DESELECT	Precharge Power Down Entry	11
All Banks Idle	H	L	DESELECT	Precharge Power Down Entry	11, 12, 13, 17
	H	L	REFRESH	Self Refresh Entry	9, 12, 17
For more details with all signals See “Command Truth Table”.					10

Notes

- CKE (N) is the logic state of CKE at clock edge N; CKE (N-1) was the state of CKE at the previous clock edge.
- Current state is defined as the state of the DDR4 SDRAM immediately prior to clock edge N.
- COMMAND (N) is the command registered at clock edge N, and ACTION (N) is a result of COMMAND (N), ODT is not included here.
- All states and sequences not shown are illegal or reserved unless explicitly described elsewhere in this document.
- The state of ODT does not affect the states described in this table. The ODT function is not available during Self-Refresh.
- During any CKE transition (registration of CKE H→L or CKE L→H), the CKE level must be maintained until 1nCK prior to tCKEmin being satisfied (at which time CKE may transition again).
- DESELECT and NOP are defined in the Command Truth Table.
- On Self-Refresh Exit DESELECT commands must be issued on every clock edge occurring during the tXS period. Read or ODT commands may be issued only after tXSDLL is satisfied.
- Self-Refresh mode can only be entered from the All Banks Idle state.
- Must be a legal command as defined in the Command Truth Table.
- Valid commands for Power-Down Entry and Exit are DESELECT only.
- Self-Refresh cannot be entered during Read or Write operations. For a detailed list of restrictions see “Self Refresh Operation” and “Power Down Mode” sections.
- The Power-Down does not perform any refresh operations.
- “X” means “don’t care”(including floating around VREF) in Self-Refresh and Power-Down. It also applies to Address pins.
- VPP and VREF (VREFCA) must be maintained during Self-Refresh operation.
- If all banks are closed at the conclusion of the read, write or precharge command, then Precharge Power-Down is entered, otherwise Active Power-Down is entered.
- “Idle state” is defined as all banks are closed (tRP, tDAL, etc. satisfied), no data bursts are in progress, CKE is high, and all timings from previous operations are satisfied (tMRD, tMOD, tRFC, tZQinit, tZQoper, tZQCS, etc.) as well as all Self-Refresh exit and Power-Down Exit parameters are satisfied (tXS, tXP, etc)

9.3 No Operation (NOP) Command

The No Operation (NOP) command is used to instruct the selected DDR4 SDRAM to perform a NOP (CS_n LOW and ACT_n, RAS_n/A16, CAS_n/A15, and WE_n/A14 HIGH). This prevents unwanted commands from being registered during idle or wait states. NOP command general support has been removed and the command should not be used unless specifically allowed, which is when exiting maximum power-saving mode or when entering gear-down mode.

9.4 Deselect Command

The DESELECT function (CS_n HIGH) prevents new commands from being executed by the DDR4 SDRAM. The DDR4 SDRAM is effectively deselected. Operations already in progress are not affected.



9.5 Burst Length, Type and Order

Accesses within a given burst may be programmed to sequential or interleaved order. The burst type is selected via bit A3 of Mode Register MR0. The ordering of accesses within a burst is determined by the burst length, burst type, and the starting column address as shown in Table 18. The burst length is defined by bits A0-A1 of Mode Register MR0. Burst length options include fixed BC4, fixed BL8, and on-the-fly (OTF), which allows BC4 or BL8 to be selected coincident with the registration of a Read or Write command via A12/BC_n.

Table 18 – Burst Type and Burst Order

Burst Length	Read/Write	Starting Column Address (A2,A1,A0)	burst type = Sequential (decimal) A3=0	burst type = Interleaved (decimal) A3=1	Notes
4 Chop	READ	0 0 0	0,1,2,3,T,T,T,T	0,1,2,3,T,T,T,T	1,2,3
		0 0 1	1,2,3,0,T,T,T,T	1,0,3,2,T,T,T,T	1,2,3
		0 1 0	2,3,0,1,T,T,T,T	2,3,0,1,T,T,T,T	1,2,3
		0 1 1	3,0,1,2,T,T,T,T	3,2,1,0,T,T,T,T	1,2,3
		1 0 0	4,5,6,7,T,T,T,T	4,5,6,7,T,T,T,T	1,2,3
		1 0 1	5,6,7,4,T,T,T,T	5,4,7,6,T,T,T,T	1,2,3
		1 1 0	6,7,4,5,T,T,T,T	6,7,4,5,T,T,T,T	1,2,3
		1 1 1	7,4,5,6,T,T,T,T	7,6,5,4,T,T,T,T	1,2,3
	WRITE	0,V,V	0,1,2,3,X,X,X,X	0,1,2,3,X,X,X,X	1,2,4,5
		1,V,V	4,5,6,7,X,X,X,X	4,5,6,7,X,X,X,X	1,2,4,5
8	READ	0 0 0	0,1,2,3,4,5,6,7	0,1,2,3,4,5,6,7	2
		0 0 1	1,2,3,0,5,6,7,4	1,0,3,2,5,4,7,6	2
		0 1 0	2,3,0,1,6,7,4,5	2,3,0,1,6,7,4,5	2
		0 1 1	3,0,1,2,7,4,5,6	3,2,1,0,7,6,5,4	2
		1 0 0	4,5,6,7,0,1,2,3	4,5,6,7,0,1,2,3	2
		1 0 1	5,6,7,4,1,2,3,0	5,4,7,6,1,0,3,2	2
		1 1 0	6,7,4,5,2,3,0,1	6,7,4,5,2,3,0,1	2
		1 1 1	7,4,5,6,3,0,1,2	7,6,5,4,3,2,1,0	2
	WRITE	V,V,V	0,1,2,3,4,5,6,7	0,1,2,3,4,5,6,7	2,4

Notes:

- In case of burst length being fixed to 4 by MR0 setting, the internal write operation starts two clock cycles earlier than for the BL8 mode. This means that the starting point for tWR and tWTR will be pulled in by two clocks. In case of burst length being selected on-the-fly via A12/BC_n, the internal write operation starts at the same point in time like a burst of 8 write operation. This means that during on-the-fly control, the starting point for tWR and tWTR will not be pulled in by two clocks.
- 0...7 bit number is value of CA[2:0] that causes this bit to be the first read during a burst.
- Output driver for data and strobes are in high impedance.
- V: A valid logic level (0 or 1), but respective buffer input ignores level on input pins.
- X: Don't Care.

9.5.1 BL8 Burst order with CRC Enabled

DDR4 SDRAM supports fixed write burst ordering [A2:A1:A0=0:0:0] when write CRC is enabled in BL8 (fixed).



9.6 DLL-off Mode & DLL on/off switching procedure

9.6.1 DLL on/off switching procedure

DDR4 SDRAM DLL-off mode is entered by setting MR1 bit A0 to "0"; this will disable the DLL for subsequent operations until A0 bit is set back to "1".

9.6.2 DLL "on" to DLL "off" Procedure

To switch from DLL "on" to DLL "off" requires the frequency to be changed during Self-Refresh, as outlined in the following procedure:

1. Starting from Idle state (All banks pre-charged, all timings fulfilled, and DRAMs On-die Termination resistors, RTT_NOM, must be in high impedance state before MRS to MR1 to disable the DLL.)
2. Set MR1 bit A0 to "0" to disable the DLL.
3. Wait tMOD.
4. Enter Self Refresh Mode; wait until (tCKSRE) is satisfied.
5. Change frequency, in guidance with "**Input Clock Frequency Change**" on section 9.8.
6. Wait until a stable clock is available for at least (tCKSRX) at DRAM inputs.
7. Starting with the Self Refresh Exit command, CKE must continuously be registered HIGH until all tMOD timings from any MRS command are satisfied. In addition, if any ODT features were enabled in the mode registers when Self Refresh mode was entered, the ODT signal must continuously be registered LOW until all tMOD timings from any MRS command are satisfied. If RTT_NOM features were disabled in the mode registers when Self Refresh mode was entered, ODT signal is Don't Care.
8. Wait tXS_Fast or tXS_Abort or tXS, then set Mode Registers with appropriate values (especially an update of CL, CWL and WR may be necessary. A ZQCL command may also be issued after tXS_Fast).
 - tXS: ACT, PRE, PREA, REF, SRE, PDE, WR, WRS4, WRS8, WRA, WRAS4, WRAS8, RD, RDS4, RDS8, RDA, RDAS4, RDAS8.
 - tXS_Fast: ZQCL, ZQCS, MRS commands. For MRS command, only DRAM CL and WR/RTP register in MR0, CWL register in MR2 and gear-down mode in MR3 are allowed to be accessed provided DRAM is not in per DRAM addressability mode. Access to other DRAM mode registers must satisfy tXS timing.
 - tXS_Abort: If the MR4 bit A9 is enabled then the DRAM aborts any ongoing refresh and does not increment the refresh counter.
The controller can issue a valid command after a delay of tXS_Abort. Upon exit from Self-Refresh, the DDR4 SDRAM requires a minimum of one extra refresh command before it is put back into Self-Refresh Mode. This requirement remains the same irrespective of the setting of the MRS bit for self refresh abort.
9. Wait for tMOD, and then DRAM is ready for next command.

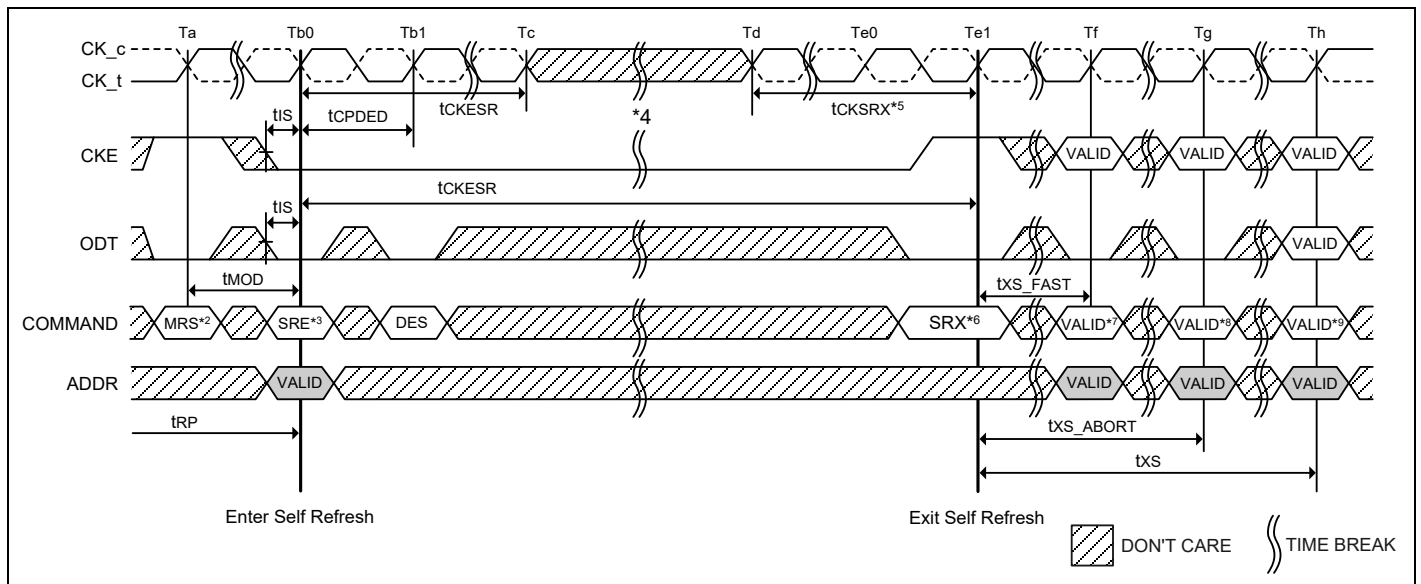
**Notes:**

1. Starting with Idle state, RTT in stable
2. Disable DLL by setting MR1 Bit A0 to 0
3. Enter SR
4. Change frequency
5. Clock must be stable tCKSRX
6. Exit SR
- 7.8.9. Update Mode Registers allowed with DLL off parameters setting

Figure 6 – DLL Switch Sequence from DLL ON to DLL OFF

9.6.3 DLL “off” to DLL “on” Procedure

To switch from DLL “off” to DLL “on” (with required frequency change) during Self-Refresh:

1. Starting from Idle state (All banks pre-charged, all timings fulfilled and DRAMs On-die Termination resistors (RTT_NOM) must be in high impedance state before Self-Refresh mode is entered.)
2. Enter Self Refresh Mode, wait until tCKSRE satisfied.
3. Change frequency, in guidance with “**Input Clock Frequency Change**” on section 9.8.
4. Wait until a stable clock is available for at least (tCKSRX) at DRAM inputs.
5. Starting with the Self Refresh Exit command, CKE must continuously be registered HIGH until tDLLK timing from subsequent DLL Reset command is satisfied. In addition, if any ODT features were enabled in the mode registers when Self Refresh mode was entered, the ODT signal must continuously be registered LOW until tDLLK timings from subsequent DLL Reset command is satisfied. If RTT_NOM were disabled in the mode registers when Self Refresh mode was entered, ODT signal is don't care.
6. Wait tXS or tXS_ABORT depending on Bit A9 in MR4, then set MR1 bit A0 to “1” to enable the DLL.
7. Wait tMRD, then set MR0 bit A8 to “1” to start DLL Reset.
8. Wait tMRD, then set Mode Registers with appropriate values (especially an update of CL, CWL and WR may be necessary. After tMOD satisfied from any proceeding MRS command, a ZQCL command may also be issued during or after tDLLK.)
9. Wait for tMOD, then DRAM is ready for next command (Remember to wait tDLLK after DLL Reset before applying command requiring a locked DLL!). In addition, wait also for tZQoper in case a ZQCL command was issued.

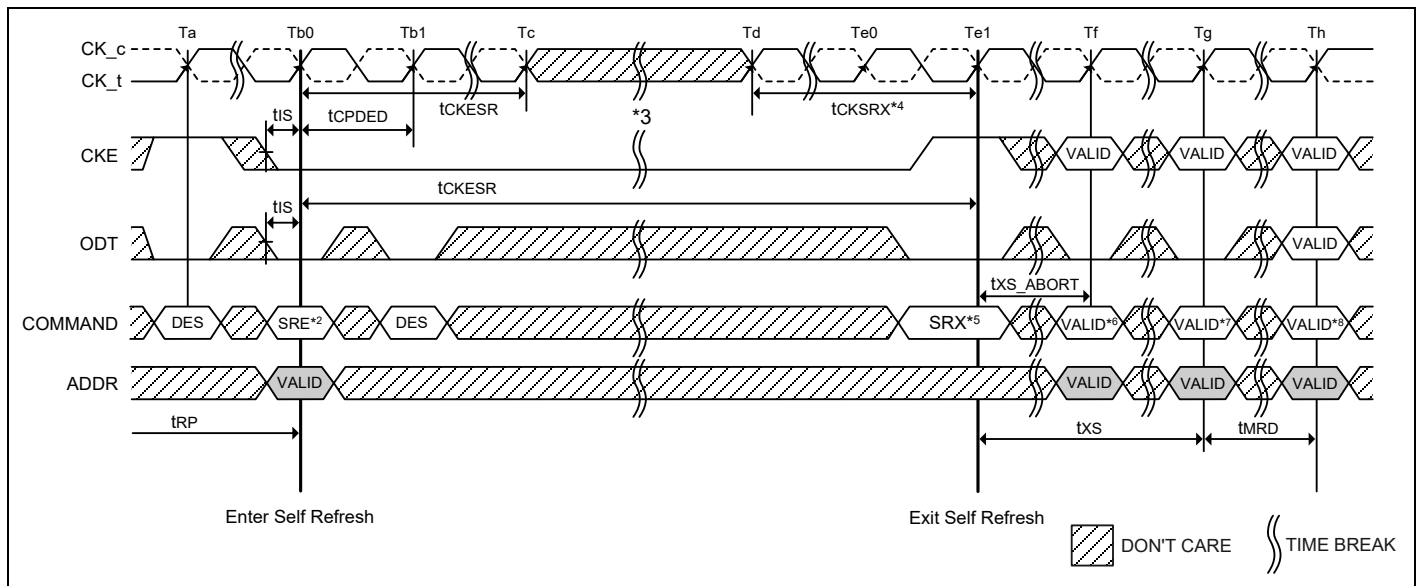
**Notes:**

1. Starting with Idle State
2. Enter SR
3. Change Frequency
4. Clock must be stable t_{CKSRX}
5. Exit SR
- 6.7. Set DLL-on by MR1 A0='1'
8. Start DLLReset
9. Update rest MR register values after t_{DLLK} (not shown in the diagram)
10. Ready for valid command after t_{DLLK} (not shown in the diagram)

Figure 7 – DLL Switch Sequence from DLL OFF to DLL ON

9.7 DLL-off Mode

DDR4 SDRAM DLL-off mode is entered by setting MR1 bit A0 to “0”; this will disable the DLL for subsequent operations until A0 bit is set back to “1”. The MR1 A0 bit for DLL control can be switched either during initialization or later. Refer to “**Input Clock Frequency Change**” on section 9.8.

The DLL-off Mode operations listed below. The maximum clock frequency for DLL-off Mode is specified by the parameter t_{CKDLL_OFF} . There is no minimum frequency limit besides the need to satisfy the refresh interval, t_{REFI} .

Due to latency counter and timing restrictions, only one value of CAS Latency (CL) in MR0 and CAS Write Latency (CWL) in MR2 are supported. The DLL-off mode is only required to support setting of both CL=10 and CWL=9. When DLL-off Mode is enabled, use of CA Parity Mode is not allowed.

DLL-off mode will affect the Read data Clock to Data Strobe relationship (t_{DQSK}), but not the Data Strobe to Data relationship (t_{DQSQ} , t_{QH}). Special attention is needed to line up Read data to controller time domain.

Comparing with DLL-on mode, where t_{DQSK} starts from the rising clock edge (AL+CL) cycles after the Read command, the DLL-off mode t_{DQSK} starts (AL+CL - 1) cycles after the read command.

Another difference is that t_{DQSK} may not be small compared to t_{CK} (it might even be larger than t_{CK}) and the difference between $t_{DQSKmin}$ and $t_{DQSKmax}$ is significantly larger than in DLL-on mode. **The t_{DQSK} (DLL-off) values are undefined and the user is responsible for training to the data-eye.**

The timing relations on DLL-off mode READ operation are shown in the following Timing Diagram (CL=10, BL=8, PL=0):



The timing relations on DLL-off mode READ operation are shown in the following Timing Diagram (CL=10, BL=8, PL=0):

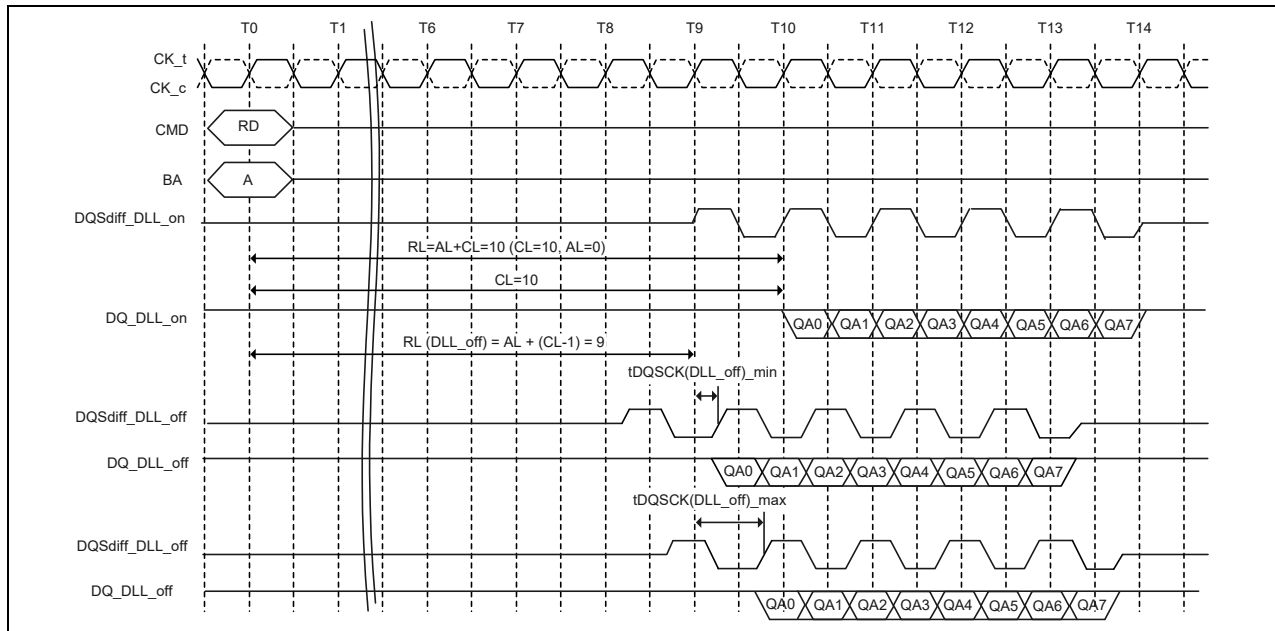

Figure 8 – READ operation at DLL-off mode

9.8 Input Clock Frequency Change

Once the DDR4 SDRAM is initialized, the DDR4 SDRAM requires the clock to be “stable” during almost all states of normal operation. This means that, once the clock frequency has been set and is to be in the “stable state”, the clock period is not allowed to deviate except for what is allowed for by the clock jitter and SSC (spread spectrum clocking) specifications.

The input clock frequency can be changed from one stable clock rate to another stable clock rate under Self-Refresh mode. Outside Self-Refresh mode, it is illegal to change the clock frequency.

Once the DDR4 SDRAM has been successfully placed into Self-Refresh mode and tCKSRE has been satisfied, the state of the clock becomes a don't care. Once a don't care, changing the clock frequency is permissible, provided the new clock frequency is stable prior to tCKSRX. When entering and exiting Self-Refresh mode for the sole purpose of changing the clock frequency, the Self-Refresh entry and exit specifications must be still met as outlined in Section 9.29 “Self Refresh Operation”.

For the new clock frequency, additional MRS commands to MR0, MR2, MR3, MR4, MR5, and MR6 may need to be issued to program appropriate CL, CWL, Gear-down mode, Read & Write Preamble, Command Address Latency (CAL Mode), Command Address Parity (CA Parity Mode), and tCCD_L/tDLLK value.

In particular, the Command Address Parity Latency (PL) must be disabled when the clock rate changes, i.e. while in Self Refresh Mode. For example, if changing the clock rate from DDR4-2133 to DDR4-3200 with CA Parity Mode enabled, MR5[2:0] must first change from PL = 4 to PL = disable prior to PL = 6. A correct procedure would be to (1) change PL = 4 to disable via MR5 [2:0], (2) enter Self Refresh Mode, (3) change clock rate from DDR4-2133 to DDR4-3200, (4) exit Self Refresh Mode, (5) Enable CA Parity Mode setting PL = 6 via MR5 [2:0].

If the MR settings that require additional clocks are updated after the clock rate has been increased, i.e. after exiting self refresh mode, the required MR settings must be updated prior to removing the DRAM from the IDLE state, unless the DRAM is RESET. If the DRAM leaves the idle state to enter self refresh mode or ZQ Calibration, the updating of the required MR settings may be deferred to after the next time the DRAM enters the IDLE state.

If MR6 is issued prior to Self Refresh Entry for new tDLLK value, then DLL will relock automatically at Self Refresh Exit. However, if MR6 is issued after Self Refresh Entry, then MR0 must be issued to reset the DLL. The DDR4 SDRAM input clock frequency is allowed to change only within the minimum and maximum operating frequency specified for the particular speed grade. Any frequency change below the minimum operating frequency would require the use of DLL_on- mode -> DLL_off -mode transition sequence, refer to section 9.6, “DLL-off Mode & DLL on/off switching procedure”.



9.9 Write Leveling

For better signal integrity, the DDR4 memory module adopted fly-by topology for the commands, addresses, control signals, and clocks. The fly-by topology has benefits from reducing number of stubs and their length, but it also causes flight time skew between clock and strobe at every DRAM on the DIMM. This makes it difficult for the Controller to maintain tDQSS, tDSS, and tDSH specification. Therefore, the DDR4 SDRAM supports a 'write leveling' feature to allow the controller to compensate for skew. This feature may not be required under some system conditions provided the host can maintain the tDQSS, tDSS and tDSH specifications.

The memory controller can use the "write leveling" feature and feedback from the DDR4 SDRAM to adjust the DQS_t - DQS_c to CK_t - CK_c relationship. The memory controller involved in the leveling must have adjustable delay setting on DQS_t - DQS_c to align the rising edge of DQS_t - DQS_c with that of the clock at the DRAM pin. The DRAM asynchronously feeds back CK_t - CK_c, sampled with the rising edge of DQS_t - DQS_c, through the DQ bus. The controller repeatedly delays DQS_t - DQS_c until a transition from 0 to 1 is detected. The DQS_t - DQS_c delay established through this exercise would ensure tDQSS specification.

Besides tDQSS, tDSS and tDSH specification also needs to be fulfilled. One way to achieve this is to combine the actual tDQSS in the application with an appropriate duty cycle and jitter on the DQS_t - DQS_c signals. Depending on the actual tDQSS in the application, the actual values for tDQSL and tDQSH may have to be better than the absolute limits provided in the chapter "AC Timing Parameters" in order to satisfy tDSS and tDSH specification. A conceptual timing of this scheme is shown in Figure 9.

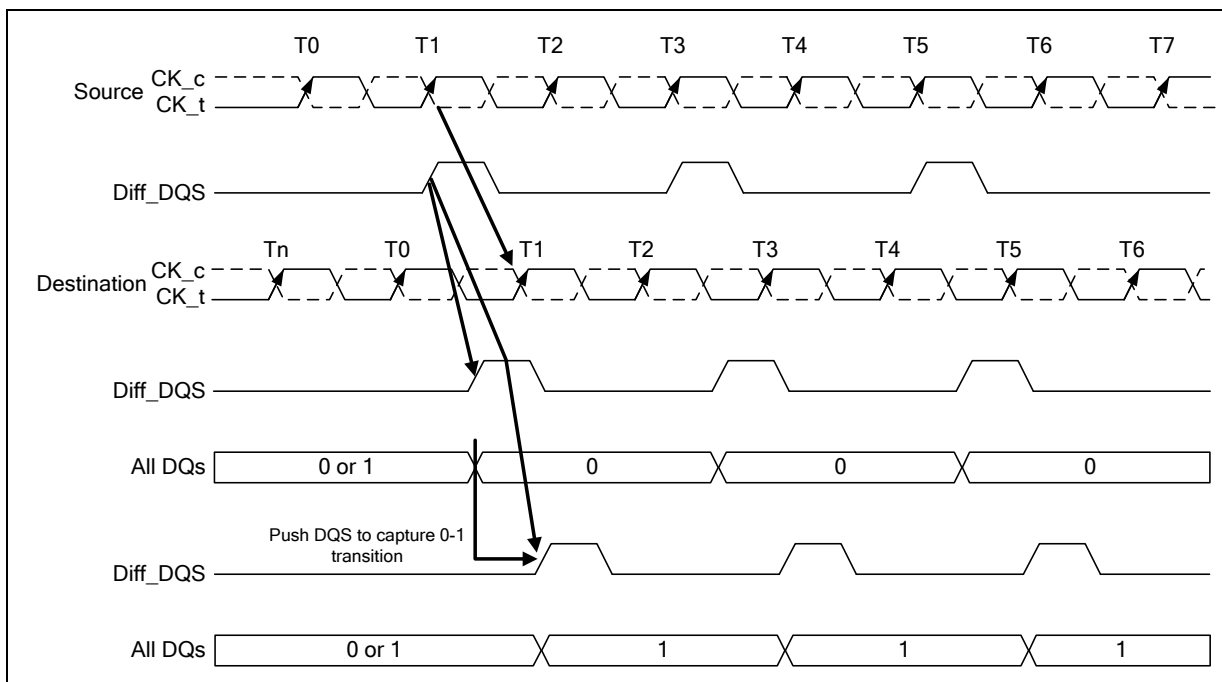

Figure 9 – Write Leveling Concept

DQS_t - DQS_c driven by the controller during leveling mode must be terminated by the DRAM based on ranks populated. Similarly, the DQ bus driven by the DRAM must also be terminated at the controller.

All data bits should carry the leveling feedback to the controller. On a x16 device, both byte lanes should be leveled independently. Therefore, a separate feedback mechanism should be available for each byte lane. The upper data bits should provide the feedback of the upper diff_DQS(diff_UDQS) to clock relationship whereas the lower data bits would indicate the lower diff_DQS(diff_LDQS) to clock relationship.



9.9.1 DRAM setting for write leveling & DRAM termination function in that mode

DRAM enters into Write leveling mode if A7 in MR1 set “High” and after finishing leveling, DRAM exits from write leveling mode if A7 in MR1 set “Low” (Table 19). Note that in write leveling mode, only DQS_t/DQS_c terminations are activated and deactivated via ODT pin, unlike normal operation (Table 20).

Table 19 – MR setting involved in the leveling procedure

Function	MR1	Enable	Disable
Write Leveling enable	A7	1	0
Output buffer mode (Qoff)	A12	0	1

Table 20 – DRAM termination function in the leveling mode

ODT pin @DRAM if RTT_NOM/PARK Value is set via MRS	DQS_t/DQS_c termination	DQs termination
RTT_NOM with ODT High	On	Off
RTT_PARK with ODT LOW	On	Off

Notes

- In Write Leveling Mode with its output buffer disabled (MR1 A[7] = 1 with MR1 A[12] = 1) all RTT_NOM and RTT_PARK settings are allowed; in Write Leveling Mode with its output buffer enabled (MR1 A[7] = 1 with MR1 A[12] = 0) all RTT_NOM and RTT_PARK settings are allowed.
- Dynamic ODT function is not available in Write Leveling Mode. DRAM MR2 A[11:9] must be “000” prior to entering Write Leveling Mode.

9.9.2 Procedure Description

The Memory controller initiates Leveling mode of all DRAMs by setting bit A7 of MR1 to 1. When entering write leveling mode, the DQ pins are in undefined driving mode. During write leveling mode, only DESELECT commands are allowed, as well as an MRS command to change Qoff bit (MR1 A[12]) and an MRS command to exit write leveling (MR1 A[7]). Upon exiting write leveling mode, the MRS command performing the exit (MR1 A[7]=0) may also change MR1 bits of A12-A8 ,A2-A1. Since the controller levels one rank at a time, the output of other ranks must be disabled by setting MR1 bit A12 to 1. The Controller may assert ODT after tMOD, at which time the DRAM is ready to accept the ODT signal.

The Controller may drive DQS_t low and DQS_c high after a delay of tWLDQSEN, at which time the DRAM has applied on-die termination on these signals. After tDQSL and tWLMRD, the controller provides a single DQS_t, DQS_c edge which is used by the DRAM to sample CK_t - CK_c driven from controller. tWLMRD(max) timing is controller dependent.

DRAM samples CK_t - CK_c status with rising edge of DQS_t - DQS_c and provides feedback on all the DQ bits asynchronously after tWLO timing. There is a DQ output uncertainty of tWLOE defined to allow mismatch on DQ bits. The tWLOE period is defined from the transition of the earliest DQ bit to the corresponding transition of the latest DQ bit. There are no read strobes (DQS_t/DQS_c) needed for these DQs. Controller samples incoming DQs and decides to increment or decrement DQS_t - DQS_c delay setting and launches the next DQS_t/DQS_c pulse after some time, which is controller dependent. Once a 0 to 1 transition is detected, the controller locks DQS_t - DQS_c delay setting and writes leveling is achieved for the device. Figure 10 describes the timing diagram and parameters for the overall Write Leveling procedure.

Parameter	Symbol	DDR4-1600,1866,2133,2400		DDR4-2666,3200		Units	Note
		Min	Max	Min	Max		
Write leveling output error	tWLOE	0	2	0	2	nS	

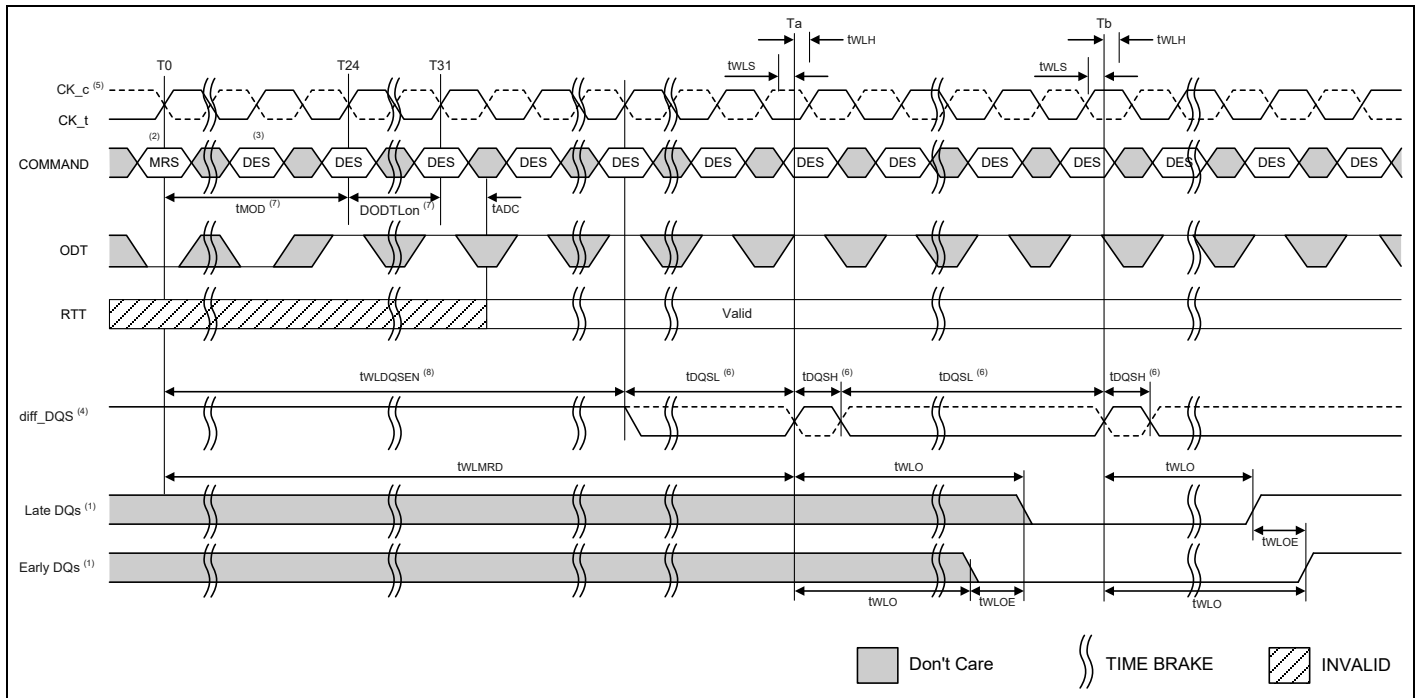

Notes

1. DDR4 SDRAM drives leveling feedback on all DQs.
2. MRS: Load MR1 to enter write leveling mode.
3. DES: Deselect.
4. diff_DQS is the differential data strobe (DQS_t-DQS_c). Timing reference points are the zero crossings. DQS_t is shown with solid line; DQS_c is shown with dotted line.
5. CK_t/CK_c: CK_t is shown with solid dark line, whereas CK_c is drawn with dotted line.
6. DQS_t, DQS_c needs to fulfill minimum pulse width requirements tDQSH(min) and tDQSL(min) as defined for regular Writes; the max pulse width is system dependent.
7. tMOD(Min) = max(24nCK, 15nS), WL = 9 (CWL = 9, AL = 0, PL = 0), DODTLon = WL -2 = 7.
8. tWLDQSEN must be satisfied following equation when using ODT.
 - tWLDQSEN > tMOD(Min) + ODTLon + tADC: at DLL = Enable
 - tWLDQSEN > tMOD(Min) + tAONAS: at DLL = Disable

Figure 10 – Timing details of Write leveling sequence [DQS_t - DQS_c is capturing CK_t - CK_c low at Ta and CK_t - CK_c high at Tb



9.9.3 Write Leveling Mode Exit

The following sequence describes how the Write Leveling Mode should be exited:

1. After the last rising strobe edge (see ~T0), stop driving the strobe signals (see ~Tc0). Note: From now on, DQ pins are in undefined driving mode, and will remain undefined, until tMOD after the respective MRS command (Te1).
2. Drive ODT pin low (tIS must be satisfied) and continue registering low. (see Tb0).
3. After the RTT is switched off, disable Write Level Mode via MRS command (see Tc2).
4. After tMOD is satisfied (Te1), any valid command may be registered. (MRS commands may be issued after tMRD (Td1).

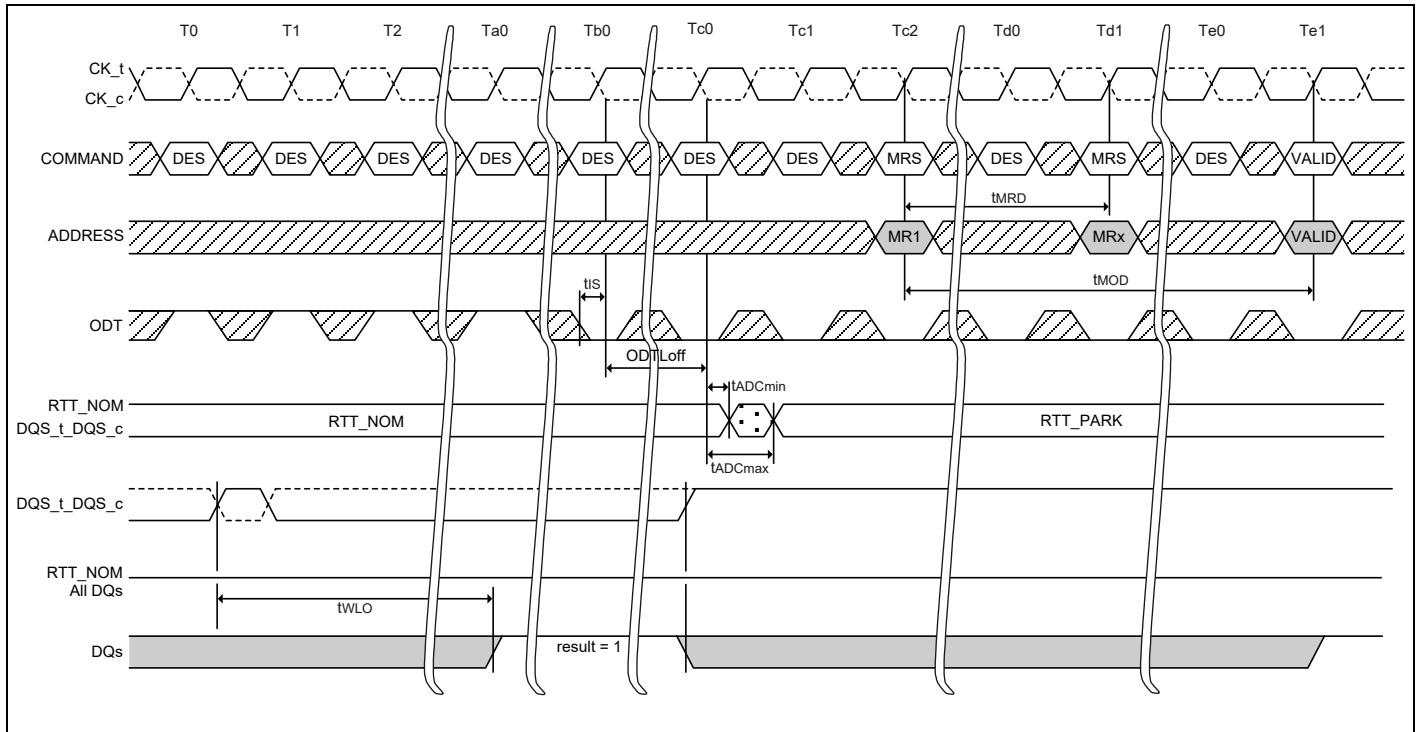

Figure 11 – Timing details of Write leveling exit



9.10 Temperature controlled Refresh modes

This mode is Temperature Controlled Refresh Mode (i.e. TCR), enabled and disabled by setting bit A3 in MR4. Two modes are supported that are selected by bit A2 setting in MR4.

During normal operation, Temperature Controlled Refresh (TCR) mode is disabled by setting bit A3=0 in MR4, the device Refresh command must be issued once every tREFI 7.8μS when $-40^{\circ}\text{C} \leq \text{TCASE} \leq 85^{\circ}\text{C}$, once every tREFI 3.9μS when $85^{\circ}\text{C} < \text{TCASE} \leq 95^{\circ}\text{C}$, once every tREFI 1.95μS when $95^{\circ}\text{C} < \text{TCASE} \leq 105^{\circ}\text{C}$.

When TCR mode is enabled, the device will register the externally supplied Refresh command and adjust the internal refresh interval to be longer than tREFI of the normal temperature mode, when allowed, by skipping Refresh commands with the proper ratio.

The TCR mode has two modes to select between normal temperature mode and extended temperature mode. The correct mode must be selected so the internal control operates correctly. The DRAM must have the correct refresh rate applied externally; the internal refresh rate is determined by the DRAM based on the temperature.

Temperature Controlled Refresh Enabled

Normal Temperature Mode		Extended Temperature Mode		Operating Temperature Range
External Refresh Interval (tREFI)	Internal Refresh Interval (tREFI)	External Refresh Interval (tREFI)	Internal Refresh Interval (tREFI)	
7.8μS	>>7.8μS	3.9μS*1	>>7.8μS	$-40^{\circ}\text{C} \leq \text{TCASE} < 45^{\circ}\text{C}$
7.8μS	7.8μS	3.9μS*1	7.8μS	$45^{\circ}\text{C} \leq \text{TCASE} \leq 85^{\circ}\text{C}$
N/A	N/A	3.9μS	3.9μS	$85^{\circ}\text{C} < \text{TCASE} \leq 95^{\circ}\text{C}$
N/A	N/A	1.95μS	1.95μS	$95^{\circ}\text{C} < \text{TCASE} \leq 105^{\circ}\text{C}$

Note:

1. If the external refresh period is slower than 3.9μS, the device will refresh internally at too slow of a refresh rate and will violate refresh specifications.

9.10.1 Normal temperature mode ($-40^{\circ}\text{C} \leq \text{TCASE} \leq 85^{\circ}\text{C}$)

Once this mode is enabled by setting bit A3=1 and A2=0 in MR4, Refresh commands should be issued to DDR4 SDRAM with the average periodic refresh interval (7.8μS) which is tREFI of normal temperature range ($-40^{\circ}\text{C} \sim 85^{\circ}\text{C}$). In this mode, the system guarantees that the DRAM temperature does not exceed 85°C .

When TCASE is below 45°C , DDR4 SDRAM may adjust internal average periodic refresh interval by skipping external refresh commands with proper gear ratio. Not more than three fourths of external refresh commands are skipped at any temperature in this mode. The internal average periodic refresh interval adjustment is automatically done inside the DRAM and user does not need to provide any additional control.

9.10.2 Extended temperature mode ($85^{\circ}\text{C} \leq \text{TCASE} \leq 105^{\circ}\text{C}$)

Once this mode is enabled by setting bit A3=1 and A2=1 in MR4, Refresh commands should be issued to DDR4 SDRAM with the average periodic refresh interval equal to or shorter than tREFI of extended temperature range ($85^{\circ}\text{C} \sim 105^{\circ}\text{C}$). In this mode, the system must guarantee that the TCASE does not exceed 105°C .

In the extend temperature range ($85^{\circ}\text{C} \sim 105^{\circ}\text{C}$), DDR4 SDRAM adjusts its internal average periodic refresh interval to tREFI of the normal temperature range by skipping external refresh commands with proper gear ratio. When TCASE is below 45°C , DDR4 SDRAM may further adjust internal average periodic refresh interval. Not more than seven eighths of external commands are skipped at any temperature in this mode. The internal average periodic refresh interval adjustment is automatically done inside the DRAM and user does not need to provide any additional control.



9.11 Fine Granularity Refresh Mode

9.11.1 Mode Register and Command Truth Table

The Refresh cycle time (tRFC) and the average Refresh interval (tREFI) of DDR4 SDRAM can be programmed by MRS command. The appropriate setting in the mode register will set a single set of Refresh cycle time and average Refresh interval for the DDR4 SDRAM device (fixed mode), or allow the dynamic selection of one of two sets of Refresh cycle time and average Refresh interval for the DDR4 SDRAM device (on-the-fly mode). The on-the-fly mode must be enabled by MRS as shown in Table 21 before any on-the-fly Refresh command can be issued.

Table 21 – MR3 definition for Fine Granularity Refresh Mode

A8	A7	A6	Fine Granularity Refresh
0	0	0	Normal mode (Fixed 1x)
0	0	1	Fixed 2x
0	1	0	Fixed 4x
0	1	1	Reserved
1	0	0	Reserved
1	0	1	Enable on the fly 2x
1	1	0	Enable on the fly 4x
1	1	1	Reserved

There are two types of on-the-fly modes (1x/2x and 1x/4x modes) that are selectable by programming the appropriate values into the mode register. When either of the two on-the-fly modes is selected ("A8=1"), DDR4 SDRAM evaluates BG0 bit when a Refresh command is issued, and depending on the status of BG0, it dynamically switches its internal Refresh configuration between 1x and 2x (or 1x and 4x) modes, and executes the corresponding Refresh operation. The command truth table is as shown in Table 22.

Table 22 – Refresh command truth table

Function	CS_n	ACT_n	RAS_n/ A16	CAS_n/ A15	WE_n/ A14	BG0	BA0-1	A10/AP	A0-9, A11-12, A16	MR3 Setting
Refresh (Fixed rate)	L	H	L	L	H	V	V	V	V	A8 = "0"
Refresh (on-the-fly 1x)	L	H	L	L	H	L	V	V	V	A8 = "1"
Refresh (on-the-fly 2x)	L	H	L	L	H	H	V	V	V	A[8:6] = "101"
Refresh (on-the-fly 4x)										A[8:6] = "110"

9.11.2 tREFI and tRFC parameters

The default Refresh rate mode is fixed 1x mode where Refresh commands should be issued with the normal rate, i.e., tREFI1 = tREFI(base) (for TCASE ≤ 85°C), and the duration of each refresh command is the normal refresh cycle time (tRFC1). In 2x mode (either fixed 2x or on-the-fly 2x mode), Refresh commands should be issued to the DRAM at the double frequency (tREFI2 = tREFI(base)/2) of the normal Refresh rate. In 4x mode, Refresh command rate should be quadrupled (tREFI4 = tREFI(base)/4). Per each mode and command type, tRFC parameter has different values as defined in Table 23.

The refresh command that should be issued at the normal refresh rate and has the normal refresh cycle duration may be referred to as a REF1x command. The refresh command that should be issued at the double frequency (tREFI2 = tREFI(base)/2) may be referred to as a REF2x command. Finally, the refresh command that should be issued at the quadruple rate (tREFI4 = tREFI(base)/4) may be referred to as a REF4x command.

In the Fixed 1x Refresh rate mode, only REF1x commands are permitted. In the Fixed 2x Refresh rate mode, only REF2x commands are permitted. In the Fixed 4x Refresh rate mode, only REF4x commands are permitted. When the on-the-fly 1x/2x Refresh rate mode is enabled, both REF1x and REF2x commands are permitted. When the on-the-fly 1x/4x Refresh rate mode is enabled, both REF1x and REF4x commands are permitted.



Table 23 – tREFI and tRFC parameters

Refresh Mode	Parameter		4Gb	Unit
	tREFI(base)		7.8	μS
1X mode	tREFI1	$-40^{\circ}\text{C} \leq \text{TCASE} \leq 85^{\circ}\text{C}$	tREFI(base)	μS
		$85^{\circ}\text{C} < \text{TCASE} \leq 95^{\circ}\text{C}$	tREFI(base)/2	μS
		$95^{\circ}\text{C} < \text{TCASE} \leq 105^{\circ}\text{C}$	tREFI(base)/4	μS
	tRFC1(min)		260	nS
2X mode	tREFI2	$-40^{\circ}\text{C} \leq \text{TCASE} \leq 85^{\circ}\text{C}$	tREFI(base)/2	μS
		$85^{\circ}\text{C} < \text{TCASE} \leq 95^{\circ}\text{C}$	tREFI(base)/4	μS
		$95^{\circ}\text{C} < \text{TCASE} \leq 105^{\circ}\text{C}$	tREFI(base)/8	μS
	tRFC2(min)		160	nS
4X mode	tREFI4	$-40^{\circ}\text{C} \leq \text{TCASE} \leq 85^{\circ}\text{C}$	tREFI(base)/4	μS
		$85^{\circ}\text{C} < \text{TCASE} \leq 95^{\circ}\text{C}$	tREFI(base)/8	μS
		$95^{\circ}\text{C} < \text{TCASE} \leq 105^{\circ}\text{C}$	tREFI(base)/16	μS
	tRFC4(min)		110	nS

9.11.3 Changing Refresh Rate

If Refresh rate is changed by either MRS or on the fly, new tREFI and tRFC parameters would be applied from the moment of the rate change. As shown in Figure 12, when REF1x command is issued to the DRAM, then tREF1 and tRFC1 are applied from the time that the command was issued. And then, when REF2x command is issued, then tREF2 and tRFC2 should be satisfied.

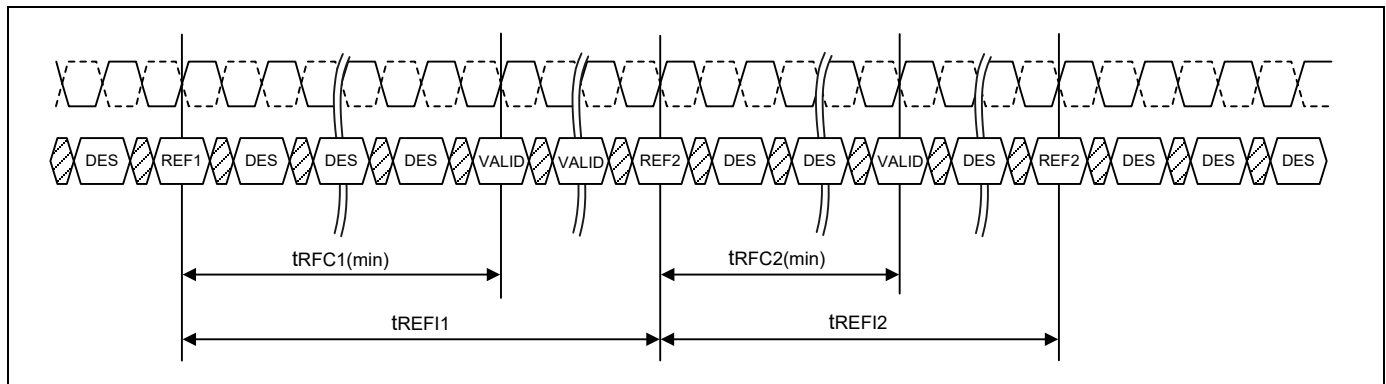

Figure 12 – On-the-fly Refresh Command Timing

The following conditions must be satisfied before the Refresh rate can be changed. Otherwise, data retention of DDR4 SDRAM cannot be guaranteed.

1. In the fixed 2x Refresh rate mode or the on-the-fly 1x/2x Refresh mode, an even number of REF2x commands must be issued to the DDR4 SDRAM since the last change of the Refresh rate mode with an MRS command before the Refresh rate can be changed by another MRS command.
2. In the on-the-fly 1x/2x Refresh rate mode, an even number of REF2x commands must be issued between any two REF1x commands.
3. In the fixed 4x Refresh rate mode or the on-the-fly 1x/4x Refresh mode, a multiple of-four number of REF4x commands must be issued to the DDR4 SDRAM since the last change of the Refresh rate with an MRS command before the Refresh rate can be changed by another MRS command.
4. In the on-the-fly 1x/4x Refresh rate mode, a multiple-of-four number of REF4x commands must be issued between any two REF1x commands.

There are no special restrictions for the fixed 1x Refresh rate mode. Switching between fixed and on-the-fly modes keeping the same rate is not regarded as a Refresh rate change.



9.11.4 Usage with Temperature Controlled Refresh mode

If the Temperature Controlled Refresh mode is enabled, then only the normal mode (Fixed 1x mode; MR3 A[8:6] = 000) is allowed. If any other Refresh mode than the normal mode is selected, then the temperature controlled Refresh mode must be disabled.

9.11.5 Self Refresh entry and exit

DDR4 SDRAM can enter Self Refresh mode anytime in 1x, 2x and 4x mode without any restriction on the number of Refresh commands that has been issued during the mode before the Self Refresh entry. However, upon Self Refresh exit, extra Refresh command(s) may be required depending on the condition of the Self Refresh entry. The conditions and requirements for the extra Refresh command(s) are defined as follows:

1. There are no special restrictions on the fixed 1x Refresh rate mode.
2. In the fixed 2x Refresh rate mode or the enable-on-the-fly 1x/2x Refresh rate mode, it is recommended that there should be an even number of REF2x commands before entry into Self Refresh since the last Self Refresh exit or REF1x command or MRS command that set the refresh mode. If this condition is met, no additional refresh commands are required upon Self Refresh exit. In the case that this condition is not met, either one extra REF1x command or two extra REF2x commands are required to be issued to the DDR4 SDRAM upon Self Refresh exit. These extra Refresh commands are not counted toward the computation of the average refresh interval (tREFI).
3. In the fixed 4x Refresh rate mode or the enable-on-the-fly 1x/4x Refresh rate mode, it is recommended that there should be a multiple-of-four number of REF4x commands before entry into Self Refresh since the last Self Refresh exit or REF1x command or MRS command that set the refresh mode. If this condition is met, no additional refresh commands are required upon Self Refresh exit. In the case that this condition is not met, either one extra REF1x command or four extra REF4x commands are required to be issued to the DDR4 SDRAM upon Self Refresh exit. These extra Refresh commands are not counted toward the computation of the average refresh interval (tREFI).

9.12 Multi Purpose Register

9.12.1 DQ Training with MPR

The DDR4 DRAM contains four 8bit programmable MPR registers used for DQ bit pattern storage. These registers once programmed are activated with MRS read commands to drive the MPR bits on to the DQ bus during link training.

And DDR4 SDRAM only supports following command, MRS, RD, RDA WR, WRA, DES, REF and Reset during MPR enable Mode: MR3 A[2] = 1.

Note that in MPR mode RDA/WRA has the same functionality as a READ/WRITE command which means the auto precharge part of RDA/WRA is ignored. Power-Down mode and Self-Refresh command also is not allowed during MPR enable Mode. No other command can be issued within tRFC after REF command and 1x Refresh is only allowed when MPR mode is Enable. During MPR operations, MPR read or write sequence must be complete prior to a refresh command.



9.12.2 MR3 definition

Mode register MR3 controls the Multi-Purpose Registers (MPR) used for training. MR3 is written by asserting CS_n, RAS_n/A16, CAS_n/A15 and WE_n/A14 low, ACT_n, BA0 and BA1 high and BG0 low while controlling the states of the address pins according to the following.

MR3 Programming:

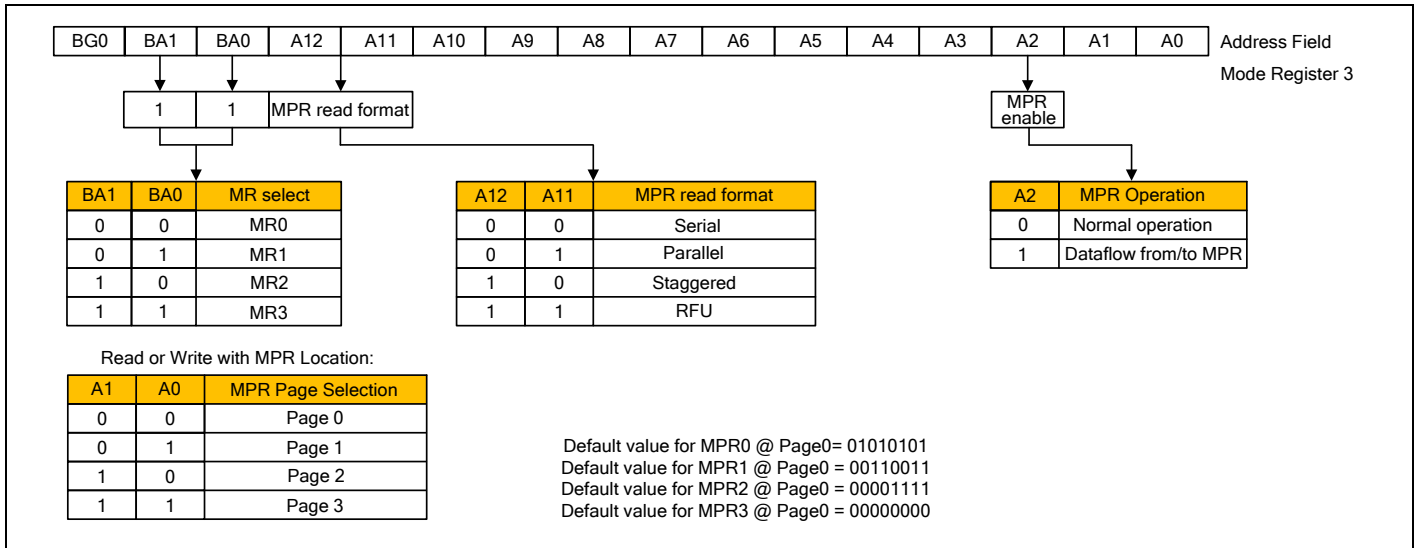

9.12.3 MPR Reads

MPR reads are supported using BL8 and BC4(Fixed) modes. BC4 on the fly is not supported for MPR reads.

In MPR Mode:

Reads (back-to-back) from Page 0 may use tCCD_S or tCCD_L timing between read commands; Reads (back-to-back) from Pages 1, 2, or 3 may not use tCCD_S timing between read commands; tCCD_L must be used for timing between read commands.

MPR reads using BC4:

BA1 and BA0 indicate the MPR location within the selected page in MPR Mode.

A10 and other address pins are don't care including BG0.

Read commands for BC4 are supported with starting column address of A[2:0] = "000" and "100".

Data Bus Inversion (DBI) is not allowed during MPR Read operation. During MPR Read, DRAM ignores Read DBI Enable setting in MR5 bit A12 in MPR mode.

DDR4 MPR mode is enabled by programming bit A2=1 and then reads are done from a specific MPR location.

MPR location is specified with the Read command using Bank address bits BA1 and BA0.

Each MPR location is 8 bit wide.

STEPS:

DLL must be locked prior to MPR Reads. If DLL is Enabled: MR1 A[0] = 1

Precharge all

Wait until tRP is satisfied

MRS MR3, Opcode A2 = "1"b

- Redirect all subsequent read and writes to MPR locations



Wait until tMRD and tMOD satisfied.

Read command

- A[1:0] = "00"b (data burst order is fixed starting at nibble, always 00b here)
- A[2] = "0"b (For BL=8, burst order is fixed at 0, 1, 2, 3, 4, 5, 6, 7)
(For BC=4, burst order is fixed at 0, 1, 2, 3, T, T, T, T)

or

- A[2] = 1 (For BL=8: Not Support)
(For BC=4, burst order is fixed at 4, 5, 6, 7, T, T, T, T)
- A12/BC = 0 or 1: Burst length supports only BL8 and BC4(Fixed), not supports BC4(OTF).

When MR0 A[1:0] is set "01" , A12/BC must be always "1"b in MPR read commands (BL8 only).

- BA1 and BA0 indicate the MPR location
- A10 and other address pins are don't care including BG0

After RL= AL + CL, DRAM bursts out the data from MPR location. The format of data on return is described in a later section and controlled by MR3 bits A0, A1, A11 and A12.

Memory controller repeats these calibration reads until read data capture at memory controller is optimized. Read MPR location can be a different location as specified by the Read command

After end of last MPR read burst, wait until tMPRR is satisfied

MRS MR3, Opcode A2 = "0"b

All subsequent reads and writes from DRAM array

Wait until tMRD and tMOD are satisfied

Continue with regular DRAM commands like Activate.

This process is depicted below (PL=0).

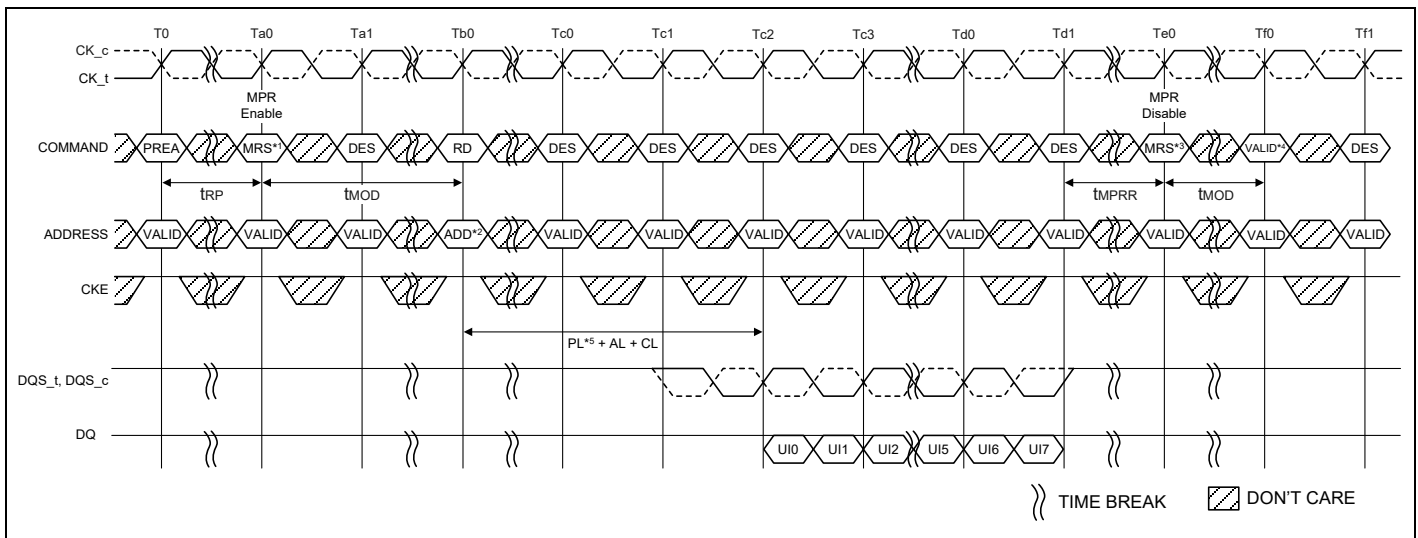



Notes:

1. Multi-Purpose Registers Read/Write Enable (MR3 A2 = 1).
 - Redirect all subsequent read and writes to MPR locations
2. Address setting:
 - A[1:0] = "00"b (data burst order is fixed starting at nibble, always 00b here)
 - A[2] = "0"b (For BL=8, burst order is fixed at 0, 1, 2, 3, 4, 5, 6, 7)
 - BA1 and BA0 indicate the MPR location
 - A10 and other address pins are don't care including BG0. A12 is don't care when MR0 A[1:0] = "00" or "10" , and must be "1"b when MR0 A[1:0] = "01"
3. Multi-Purpose Registers Read/Write Disable (MR3 A2 = 0).
4. Continue with regular DRAM command.
5. PL (Parity Latency) is added to Data output delay when CA parity latency mode is enabled.

Figure 13 – MPR Read Timing

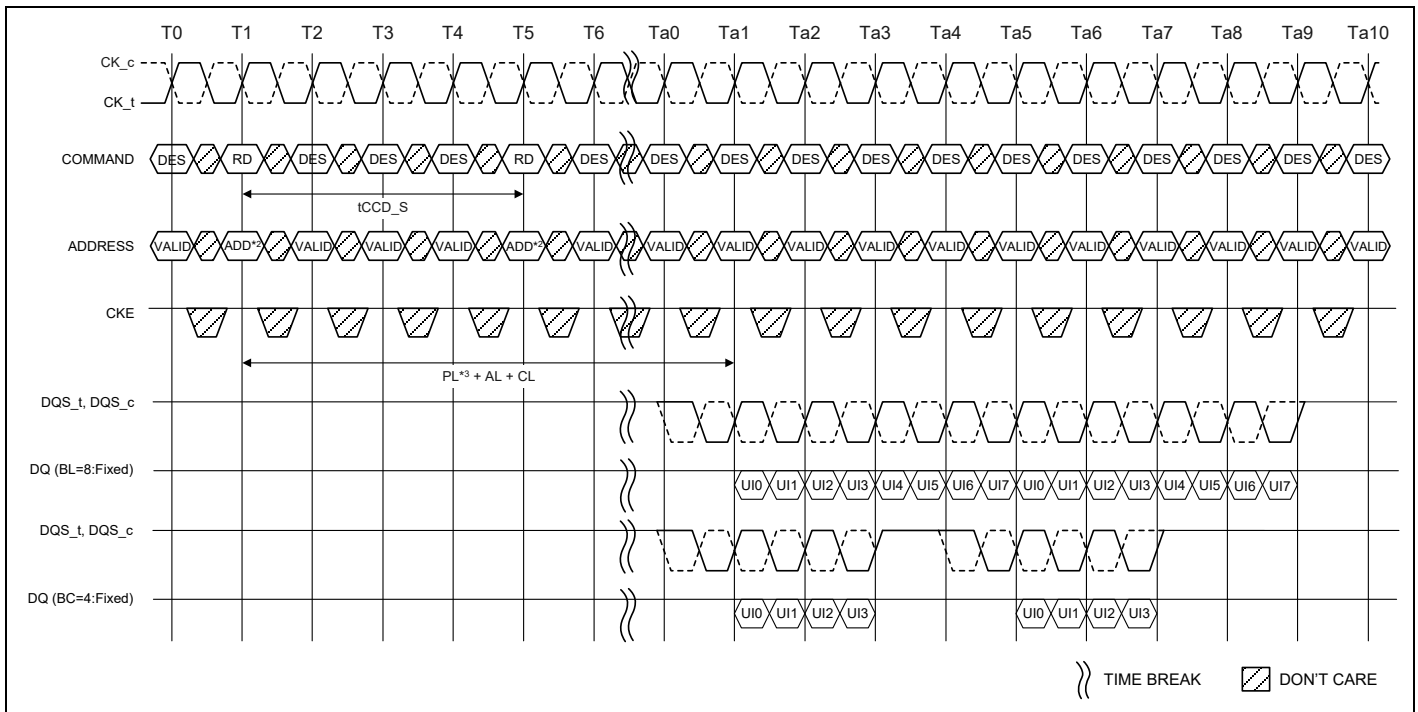

Notes:

1. tCCD_S = 4, Read Preamble = 1tCK.
2. Address setting:
 - A[1:0] = "00"b (data burst order is fixed starting at nibble, always 00b here)
 - A[2] = "0"b (For BL=8, burst order is fixed at 0, 1, 2, 3, 4, 5, 6, 7)
(For BC=4, burst order is fixed at 0, 1, 2, 3, T, T, T, T)
 - BA1 and BA0 indicate the MPR location
 - A10 and other address pins are don't care including BG0. A12 is don't care when MR0 A[1:0] = "00" or "10" , and must be "1"b when MR0 A[1:0] = "01"
3. PL (Parity Latency) is added to Data output delay when CA parity latency mode is enabled.

Figure 14 – MPR Back to Back Read Timing

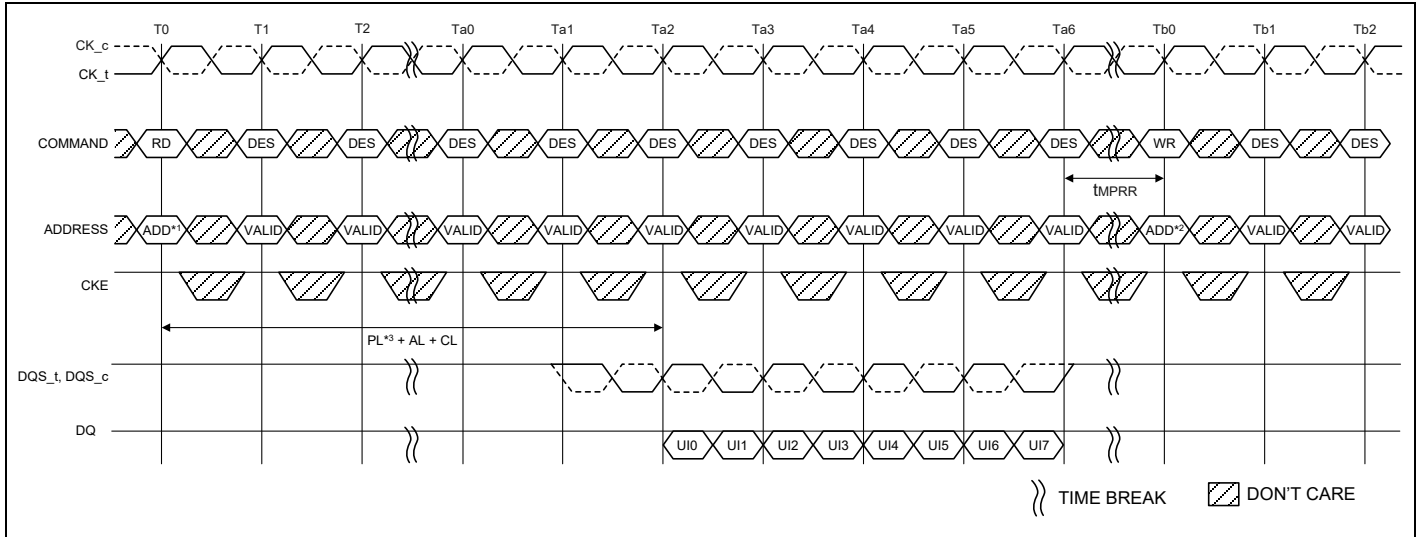

Notes:

1. Address setting:
 - A[1:0] = "00"b (data burst order is fixed starting at nibble, always 00b here)
 - A[2] = "0"b (For BL=8, burst order is fixed at 0, 1, 2, 3, 4, 5, 6, 7)
 - BA1 and BA0 indicate the MPR location
 - A10 and other address pins are don't care including BG0. A12 is don't care when MR0 A[1:0] = "00", and must be "1"b when MR0 A[1:0] = "01"
2. Address setting:
 - BA1 and BA0 indicate the MPR location
 - A [7:0] = data for MPR
 - A10 and other address pins are don't care.
3. PL (Parity Latency) is added to Data output delay when CA parity latency mode is enabled.

Figure 15 – MPR Read to Write Timing

9.12.4 MPR Writes

DDR4 allows 8 bit writes to the MPR location using the address bus A7:A0.

Table 24 – UI and Address Mapping for MPR Location

MPR Location	[7]	[6]	[5]	[4]	[3]	[2]	[1]	[0]
SDRAM Address	A7	A6	A5	A4	A3	A2	A1	A0
UI	UI0	UI1	UI2	UI3	UI4	UI5	UI6	UI7

Steps:

DLL must be locked prior to MPR Writes. If DLL is Enabled: MR1 A[0] = 1

Precharge all

Wait until tRP is satisfied

MRS MR3, Opcode A2 = "1"b

Redirect all subsequent read and writes to MPR locations

Wait until tMRD and tMOD satisfied.

Write command

BA1 and BA0 indicate the MPR location

A[7:0] = data for MPR

Wait until tWR_MPR satisfied, so that DRAM to complete MPR writes transaction.

Memory controller repeats these calibrations writes and reads until data capture at memory controller is optimized.

After end of last MPR read burst, wait until tMPRR is satisfied

MRS MR3, Opcode A2 = "0"b

All subsequent reads and writes from DRAM array



Wait until tMRD and tMOD are satisfied
 Continue with regular DRAM commands like Activate.
 This process is depicted in Figure 16.

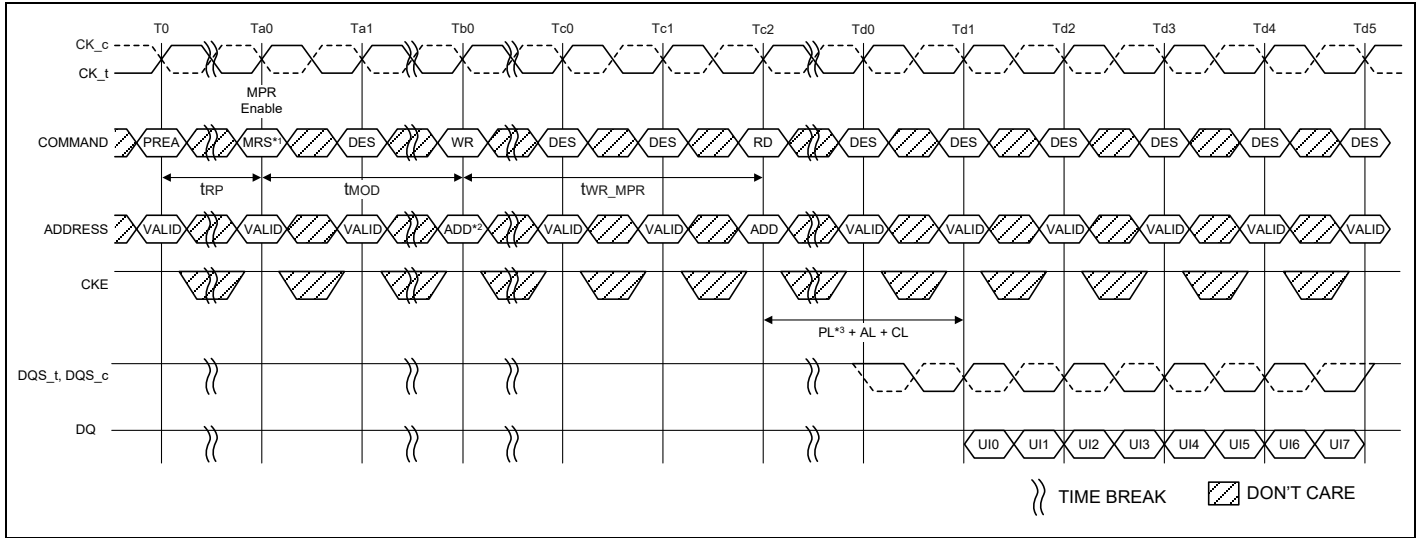

Notes:

1. Multi-Purpose Registers Read/Write Enable (MR3 A2 = 1)
2. Address setting:
 - BA1 and BA0 indicate the MPR location
 - A[7:0] = data for MPR
 - A10 and other address pins are don't care
3. PL (Parity Latency) is added to Data output delay when CA parity latency mode is enabled.

Figure 16 – MPR Write Timing and Write to Read Timing

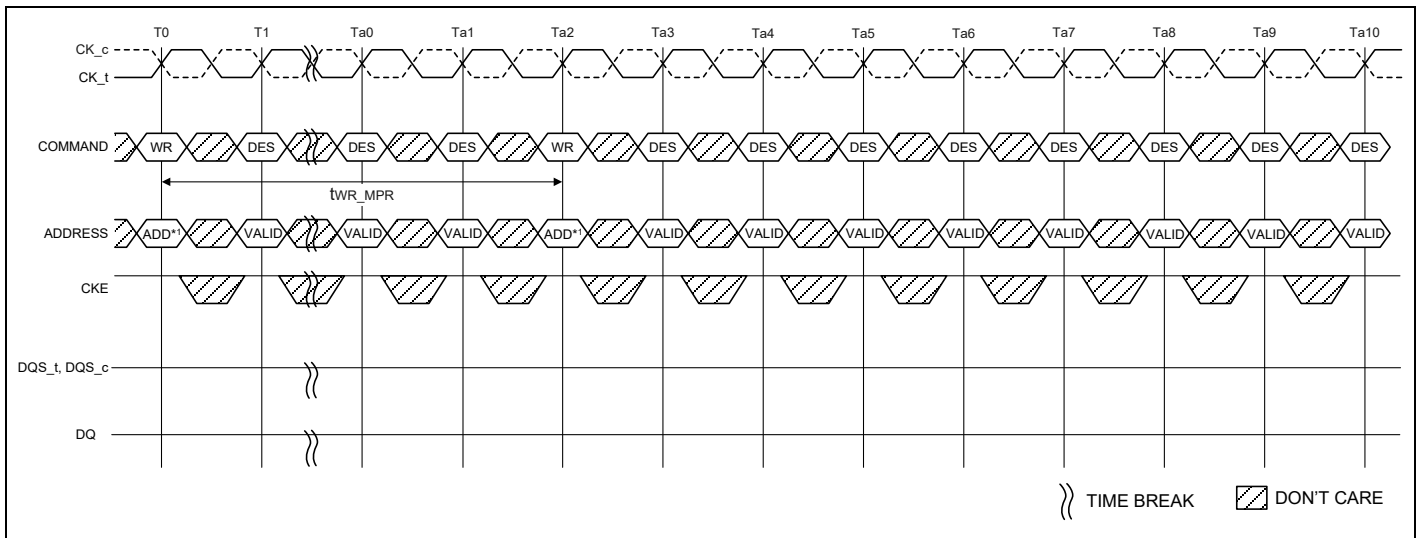

Note:

1. Address setting:
 - BA1 and BA0 indicate the MPR location
 - A[7:0] = data for MPR
 - A10 and other address pins are don't care

Figure 17 – MPR Back to Back Write Timing

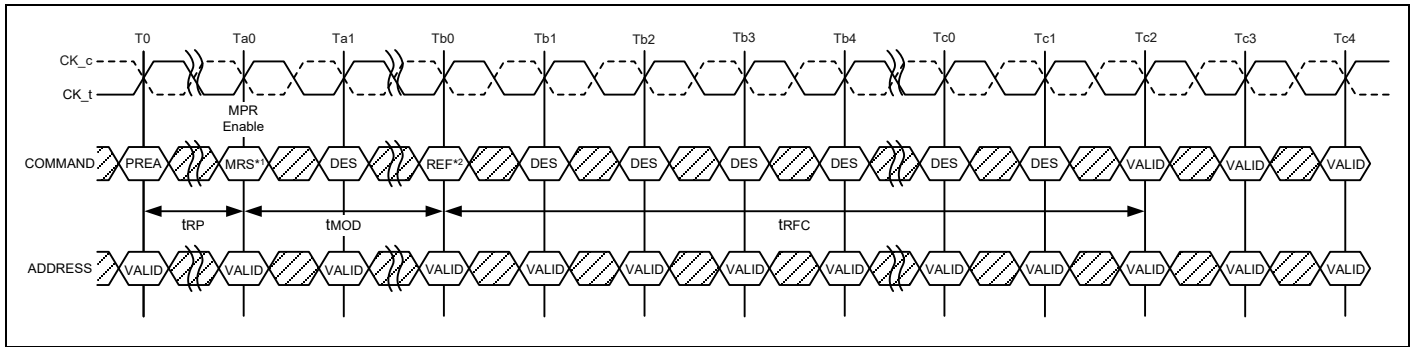

Notes:

1. Multi-Purpose Registers Read/Write Enable (MR3 A2 = 1)
- Redirect all subsequent read and writes to MPR locations
2. 1x Refresh is only allowed when MPR mode is Enabled.

Figure 18 – Refresh Command Timing

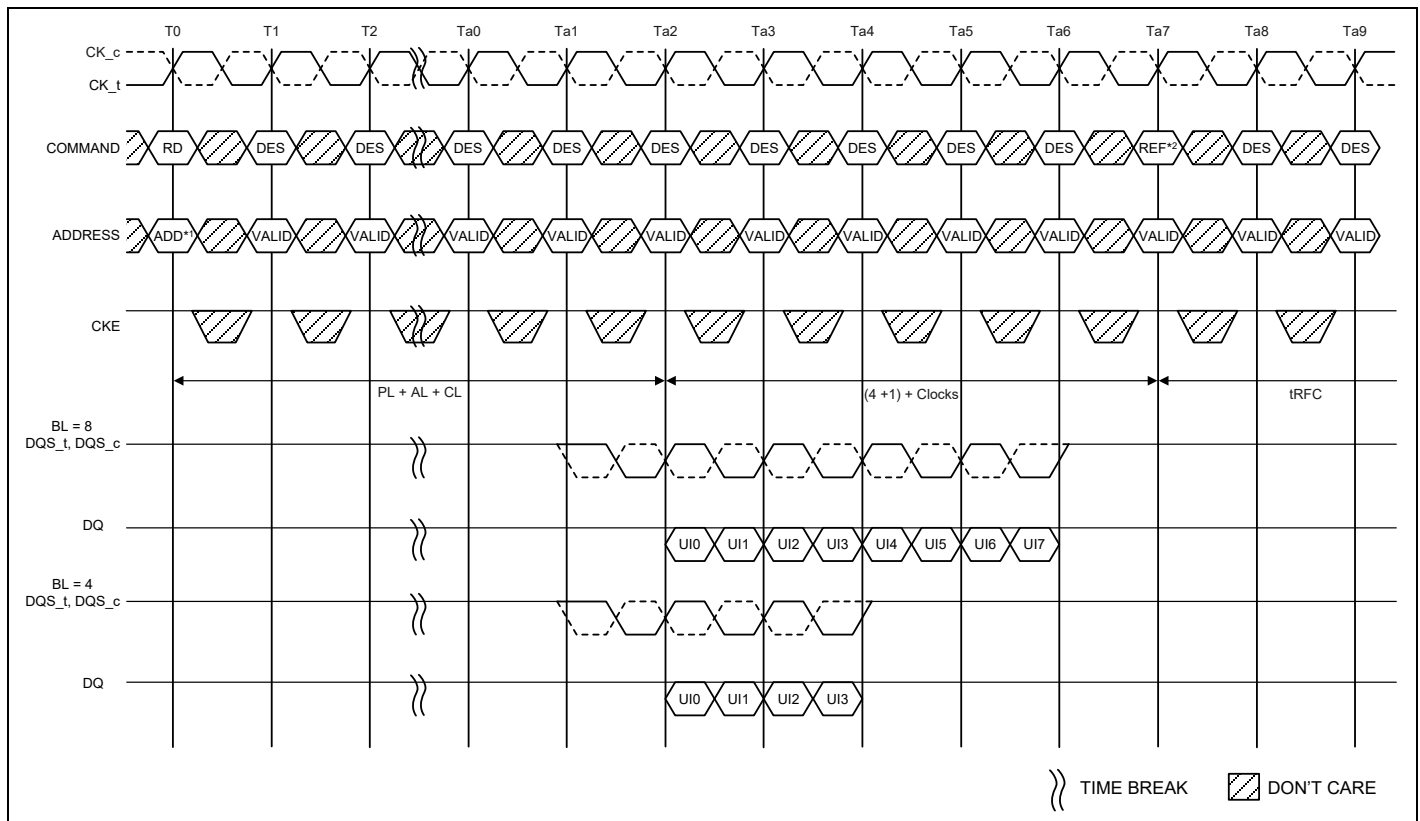

Notes:

1. Address setting:
 - A[1:0] = "00"b (data burst order is fixed starting at nibble, always 00b here)
 - A[2] = "0"b (For BL=8, burst order is fixed at 0, 1, 2, 3, 4, 5, 6, 7)
 - BA1 and BA0 indicate the MPR location
 - A10 and other address pins are don't care including BG0. A12 is don't care when MR0 A[1:0] = "00" or "10" and must be "1"b when MR0 A[1:0] = "01"
2. 1x Refresh is only allowed when MPR mode is Enabled.

Figure 19 – Read to Refresh Command Timing

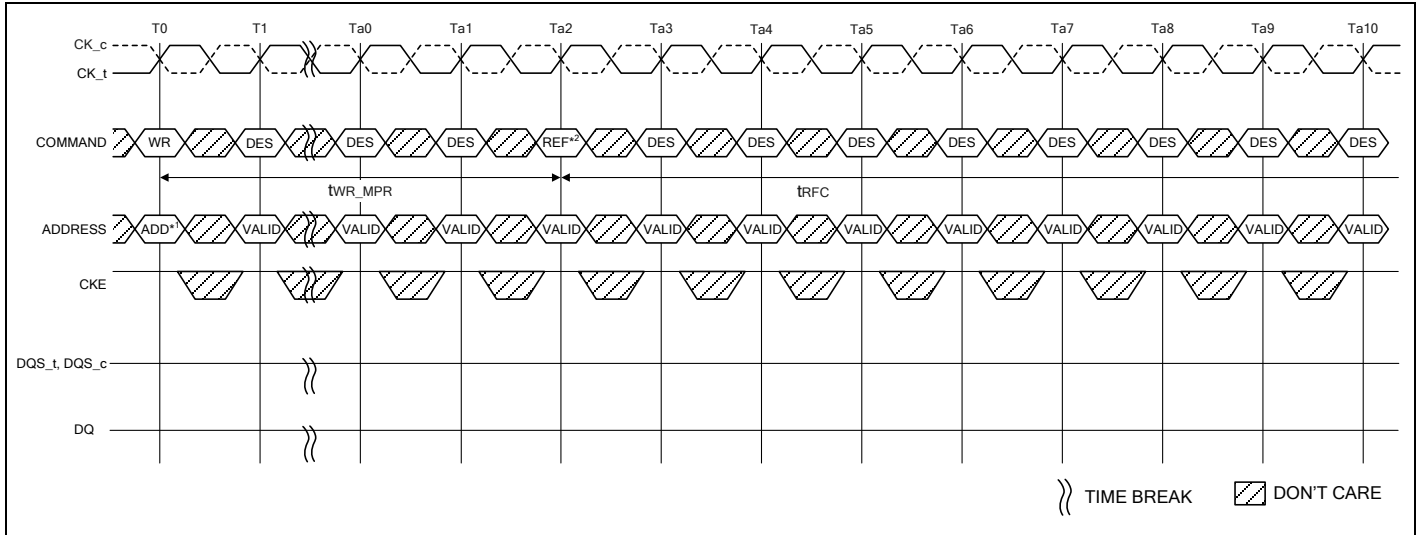

Notes:

1. Address setting:
 - BA1 and BA0 indicate the MPR location
 - A[7:0] = data for MPR
 - A10 and other address pins are don't care.
2. 1x Refresh is only allowed when MPR mode is Enable.

Figure 20 – Write to Refresh Command Timing

9.12.5 MPR Read Data format

Mode bits in MR3: (A12, A11) are used to select the data return format for MPR reads. The DRAM is required to drive associated strobes with the read data returned for all read data formats.

Serial return implies that the same pattern is returned on all DQ lanes as shown in table below. Data from the MPR is used on all DQ lanes for the serial return case. Reads from MPR page0, MPR page1, MPR page2, and MPR page3 are allowed with serial data return mode.

In this example the pattern programmed in the MPR register is 0111 1111 in MPR Location [7:0].

MPR Read Data – Serial Format

Serial	UI0	UI1	UI2	UI3	UI4	UI5	UI6	UI7
DQ0	0	1	1	1	1	1	1	1
DQ1	0	1	1	1	1	1	1	1
DQ2	0	1	1	1	1	1	1	1
DQ3	0	1	1	1	1	1	1	1
DQ4	0	1	1	1	1	1	1	1
DQ5	0	1	1	1	1	1	1	1
DQ6	0	1	1	1	1	1	1	1
DQ7	0	1	1	1	1	1	1	1
DQ8	0	1	1	1	1	1	1	1
DQ9	0	1	1	1	1	1	1	1
DQ10	0	1	1	1	1	1	1	1
DQ11	0	1	1	1	1	1	1	1
DQ12	0	1	1	1	1	1	1	1
DQ13	0	1	1	1	1	1	1	1
DQ14	0	1	1	1	1	1	1	1
DQ15	0	1	1	1	1	1	1	1



Parallel return implies that the MPR data is returned in the first UI and then repeated in the remaining UI's of the burst as shown in the table below. Data from Page0 MPR registers can be used for the parallel return case as well. Read from MPR page1, MPR page2 and MPR page3 are not allowed with parallel data return mode.

In this example the pattern programmed in the Page 0 MPR register is 0111 1111: MPR Location [7:0]. For the case of x16, the same pattern is repeated on upper and lower bytes.

MPR Read Data – Parallel Format

Parallel	UI0	UI1	UI2	UI3	UI4	UI5	UI6	UI7
DQ0	0	0	0	0	0	0	0	0
DQ1	1	1	1	1	1	1	1	1
DQ2	1	1	1	1	1	1	1	1
DQ3	1	1	1	1	1	1	1	1
DQ4	1	1	1	1	1	1	1	1
DQ5	1	1	1	1	1	1	1	1
DQ6	1	1	1	1	1	1	1	1
DQ7	1	1	1	1	1	1	1	1
DQ8	0	0	0	0	0	0	0	0
DQ9	1	1	1	1	1	1	1	1
DQ10	1	1	1	1	1	1	1	1
DQ11	1	1	1	1	1	1	1	1
DQ12	1	1	1	1	1	1	1	1
DQ13	1	1	1	1	1	1	1	1
DQ14	1	1	1	1	1	1	1	1
DQ15	1	1	1	1	1	1	1	1



The third mode of data return is the staggering of the MPR data across the lanes. In this mode a read command is issued to a specific MPR and then the data is returned on the DQ from different MPR registers. Read from MPR page1, MPR page2, and MPR page3 are not allowed with staggered data return mode.

A read example to MPR0 is shown below. The same pattern is repeated on the lower nibble as on the upper nibble.

MPR Read Data – Staggered Format

Read MPR0 Command	
Stagger	UI0-7
DQ0	MPR0
DQ1	MPR1
DQ2	MPR2
DQ3	MPR3
DQ4	MPR0
DQ5	MPR1
DQ6	MPR2
DQ7	MPR3
DQ8	MPR0
DQ9	MPR1
DQ10	MPR2
DQ11	MPR3
DQ12	MPR0
DQ13	MPR1
DQ14	MPR2
DQ15	MPR3



DDR4 MPR mode enables and page selection is done by Mode Register command as shown below.

Table 25 – MPR MR3 Register Definition

Address	Operating Mode	Description
A2	MPR operation	0 = Normal 1 = Dataflow from/to MPR
A1:A0	MPR selection	00 = page0 01 = page1 10 = page2 11 = page3
A12:A11	MPR Read Format	00 = serial 01 = Parallel 10 = Staggered 11 = Reserved

Four MPR pages are provided in DDR4 SDRAM. Page 0 is for both read and write, and pages 1, 2 and 3 are read-only. Any MPR location (MPR0-3) in page 0 can be readable through any of three readout modes (serial, parallel or staggered), but pages 1, 2 and 3 support only the serial readout mode.

After power up, the content of MPR page 0 should have the default value as defined in the table. MPR page 0 can be writeable only when MPR write command is issued by controller. Unless MPR write command is issued, DRAM must keep the default value permanently, and should never change the content on its own for any purpose. When MPR write command is issued to any of read only pages (page 1, 2 or 3), the command is ignored by DRAM.

Table 26 – MPR data format

MPR page0 (Training pattern)

Address	MPR Location	[7]	[6]	[5]	[4]	[3]	[2]	[1]	[0]	Note
BA1:BA0	00 = MPR0	0	1	0	1	0	1	0	1	Read/Write (default value)
	01 = MPR1	0	0	1	1	0	0	1	1	
	10 = MPR2	0	0	0	0	1	1	1	1	
	11 = MPR3	0	0	0	0	0	0	0	0	

Note: MPRx using A7:A0 that A7 is mapped to location [7] and A0 is mapped to location [0].

MPR page1 (CA parity error log)

Address	MPR Location	[7]	[6]	[5]	[4]	[3]	[2]	[1]	[0]	Note
BA1:BA0	00 = MPR0	A[7]	A[6]	A[5]	A[4]	A[3]	A[2]	A[1]	A[0]	Read-only
	01 = MPR1	CAS_n/ A15	WE_n/ A14	A[13]	A[12]	A[11]	A[10]	A[9]	A[8]	
	10 = MPR2	PAR	ACT_n	BG[1]*2	BG[0]	BA[1]	BA[0]	A[17]*2	RAS_n /A16	
	11 = MPR3	CRC Error Status	CA Parity Error Status	CA Parity Latency*4			C[2]*3	C[1]*3	C[0]*3	

Notes:

- MPR used for CA parity error log readout is enabled by setting A[2] in MR3
- For x16 device BG[1] is not used, MPR2[5] should be treated as don't care. The 4Gb DRAM A[17] is not used, MPR2[1] should be treated as don't care.
- If a device is used in monolithic application, where C[2:0] are not used, then MPR3[2:0] should be treated as don't care.
- MPR3 bit 3~5 (CA parity latency) reflects the latest programmed CA parity latency values.



MPR page2 (MRS Readout)

Address	MPR Location	[7]	[6]	[5]	[4]	[3]	[2]	[1]	[0]	Note	
BA1:BA0	00 = MPR0	hPPR	sPPR	RTT_WR	Temperature Sensor Status		CRC Write Enable	Rtt_WR		Read-only	
		-	-	MR2	-	-	MR2	MR2			
		-	-	A11	-	-	A12	A10	A9		
	01 = MPR1	VREFDQ training range	VREFDQ training value						Gear-down Enable		
		MR6	MR6						MR3		
		A6	A5	A4	A3	A2	A1	A0	A3		
	10 = MPR2	CAS Latency				CAS Write Latency					
		MR0				MR2					
		A6	A5	A4	A2	A12	A5	A4	A3		
	11 = MPR3	Rtt_Nom			Rtt_Park			Driver Impedance			
		MR1			MR5			MR1			
		A10	A9	A8	A8	A7	A6	A2	A1		

MPR page3

Address	MPR Location	[7]	[6]	[5]	[4]	[3]	[2]	[1]	[0]	Note
BA1:BA0	00 = MPR0	don't care	don't care	don't care	don't care	don't care	don't care	don't care	don't care	Read-only
	01 = MPR1	don't care	don't care	don't care	don't care	don't care	don't care	don't care	don't care	
	10 = MPR2	don't care	don't care	don't care	don't care	don't care	don't care	don't care	don't care	
	11 = MPR3	don't care	don't care	don't care	don't care	MAC	MAC	MAC	MAC	

Table 27 – DDR4 MPR Page3 MAC Decode Value

MPR Location	A[7:4]	A2	A1	A0	Notes
Reserved	X	1	1	1	2
Reserved	X	1	1	0	2
MAC >300K	X	1	0	1	
MAC >400K	X	1	0	0	
MAC >500K	X	0	1	1	
MAC >600K	X	0	1	0	
MAC >700K	X	0	0	1	
Unknown	X	0	0	0	1

Notes:

1. Unknown means that device is not tested for MAC and pass/fail value is unknown.
2. Reserved for future device.

Table 28 – Unlimited MAC

	A3	Notes
Unlimited MAC	1	1, 2

Notes:

1. Unlimited MAC means that there is no restriction to the number of Activates in a refresh period provided DDR4 specifications are not violated, in particular tRCmin and refresh requirements.
2. All other bits A[2:0] are set to zero.



9.13 Data Mask (DM) and Data Bus Inversion (DBI)

DDR4 SDRAM supports Data Mask (DM) function and Data Bus Inversion (DBI) function.

DM & DBI & functions are programmable through the MR bit location A[12:10] in MR5 shown as Table 29.

Write operation: Either DM or DBI function can be enabled but both functions cannot be enabled simultaneously. When both DM and DBI functions are disabled, DRAM turns off its input receiver and does not expect any valid logic level.

Read operation: Only DBI function applies. When DBI function is disabled, DRAM turns off its output driver and does not drive any valid logic level.

Table 29 – DM and DBI function setting of MR5

A10	DM Enable	A11	Write DBI Enable	A12	Read DBI Enable
0	Disabled	0	Disabled	0	Disabled
1	Enabled	1	Enabled	1	Enabled

DM function during Write operation: DRAM masks the write data received on the DQ inputs if DM_n was sampled Low on a given byte lane. If DM_n was sampled high on a given byte lane, DRAM does not mask the write data and writes into the DRAM core.

DBI function during Write operation: DRAM inverts write data received on the DQ inputs if DBI_n was sampled Low on a given byte lane. If DBI_n was sampled high on a given byte lane, DRAM leaves the data received on the DQ inputs non-inverted.

DBI function during Read operation: DRAM inverts read data on its DQ outputs and drives DBI_n pin Low when the number of “0” data bits within a given byte lane is greater than 4; otherwise DRAM does not invert the read data and drives DBI_n pin high.

Table 30 – Write DQ Frame Format

	Data transfer							
	0	1	2	3	4	5	6	7
DQL[7:0]	LByte 0	LByte 1	LByte 2	LByte 3	LByte 4	LByte 5	LByte 6	LByte 7
DML_n or DBIL_n	DML0 or DBIL0	DML1 or DBIL1	DML2 or DBIL2	DML3 or DBIL3	DML4 or DBIL4	DML5 or DBIL5	DML6 or DBIL6	DML7 or DBIL7
DQU[7:0]	UByte 0	UByte 1	UByte 2	UByte 3	UByte 4	UByte 5	UByte 6	UByte 7
DMU_n or DBIU_n	DMU0 or DBIU0	DMU1 or DBIU1	DMU2 or DBIU2	DMU3 or DBIU3	DMU4 or DBIU4	DMU5 or DBIU5	DMU6 or DBIU6	DMU7 or DBIU7

Table 31 – Read DQ Frame Format

	Data transfer							
	0	1	2	3	4	5	6	7
DQL[7:0]	LByte 0	LByte 1	LByte 2	LByte 3	LByte 4	LByte 5	LByte 6	LByte 7
DBIL_n	DBIL0	DBIL1	DBIL2	DBIL3	DBIL4	DBIL5	DBIL6	DBIL7
DQU[7:0]	UByte 0	UByte 1	UByte 2	UByte 3	UByte 4	UByte 5	UByte 6	UByte 7
DBIU_n	DBIU0	DBIU1	DBIU2	DBIU3	DBIU4	DBIU5	DBIU6	DBIU7



9.14 ZQ Calibration Commands

9.14.1 ZQ Calibration Description

ZQ Calibration command is used to calibrate DRAM Ron & ODT values. DDR4 SDRAM needs longer time to calibrate output driver and on-die termination circuits at initialization and relatively smaller time to perform periodic calibrations.

ZQCL command is used to perform the initial calibration during power-up initialization sequence. This command may be issued at any time by the controller depending on the system environment. ZQCL command triggers the calibration engine inside the DRAM and, once calibration is achieved, the calibrated values are transferred from the calibration engine to DRAM IO, which gets reflected as updated output driver and on-die termination values.

The first ZQCL command issued after reset is allowed a timing period of tZQinit to perform the full calibration and the transfer of values. All other ZQCL commands except the first ZQCL command issued after RESET are allowed a timing period of tZQoper.

ZQCS command is used to perform periodic calibrations to account for voltage and temperature variations. A shorter timing window is provided to perform the calibration and transfer of values as defined by timing parameter tZQCS. One ZQCS command can effectively correct a minimum of 0.5 % (ZQ Correction) of RON and RTT impedance error within 128 nCK for all speed bins assuming the maximum sensitivities specified in the 'Output Driver Voltage and Temperature Sensitivity' and 'ODT Voltage and Temperature Sensitivity' tables. The appropriate interval between ZQCS commands can be determined from these tables and other application specific parameters. One method for calculating the interval between ZQCS commands, given the temperature (Tdriftrate) and voltage (Vdriftrate) drift rates that the SDRAM is subject to in the application, is illustrated. The interval could be defined by the following formula:

$$\frac{\text{ZQCorrection}}{(\text{TSens} \times \text{Tdriftrate}) + (\text{VSens} \times \text{Vdriftrate})}$$

Where TSens = max(dRTTdT, dRONdTM) and VSens = max(dRTTdV, dRONdVM) define the SDRAM temperature and voltage sensitivities.

For example, if TSens = 1.5% / °C, VSens = 0.15% / mV, Tdriftrate = 1°C / sec and Vdriftrate = 15 mV / sec, then the interval between ZQCS commands is calculated as:

$$\frac{0.5}{(1.5 \times 1) + (0.15 \times 15)} = 0.133 \approx 128ms$$

No other activities should be performed on the DRAM channel by the controller for the duration of tZQinit, tZQoper, or tZQCS. The quiet time on the DRAM channel allows accurate calibration of output driver and on-die termination values. Once DRAM calibration is achieved, the DRAM should disable ZQ current consumption path to reduce power.

All banks must be precharged and tRP met before ZQCL or ZQCS commands are issued by the controller. See "Command Truth Table" on section 9.1 for a description of the ZQCL and ZQCS commands.

ZQ calibration commands can also be issued in parallel to DLL lock time when coming out of self refresh. Upon Self-Refresh exit, DDR4 SDRAM will not perform an IO calibration without an explicit ZQ calibration command. The earliest possible time for ZQ Calibration command (short or long) after self refresh exit is XS, XS_Abort/ XS_FAST depending on operation mode.

In systems that share the ZQ resistor between devices, the controller must not allow any overlap of tZQoper, tZQinit, or tZQCS between the devices.

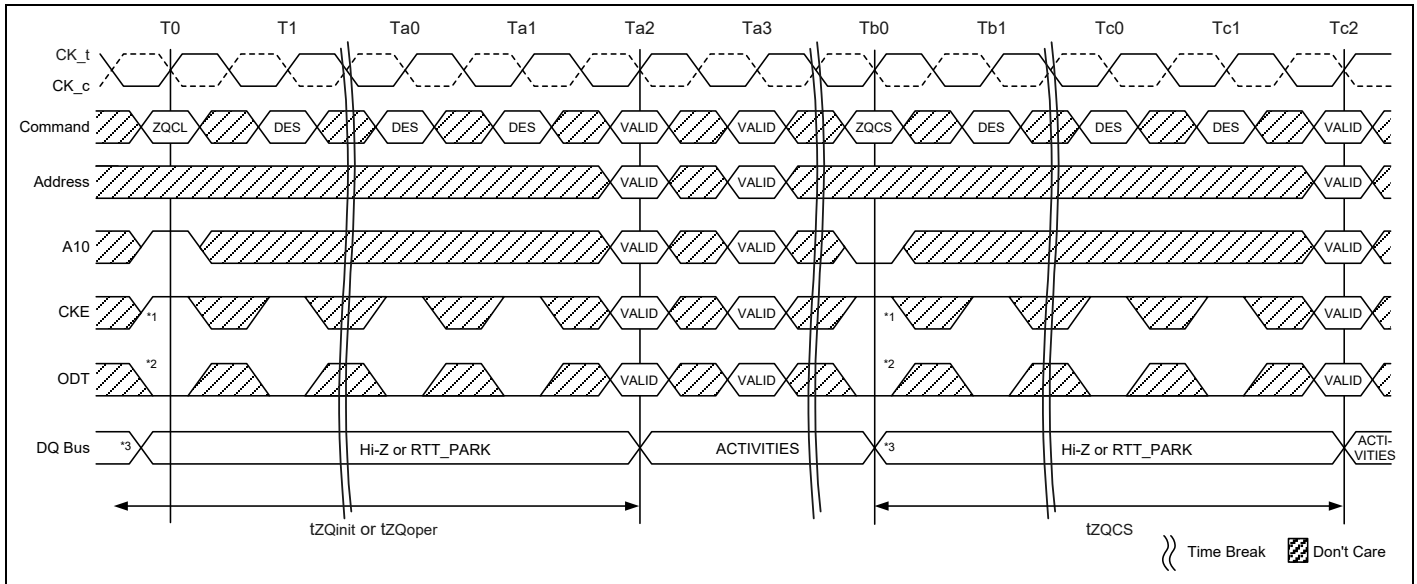

Notes:

1. CKE must be continuously registered high during the calibration procedure.
2. During ZQ Calibration, ODT signal must be held LOW and DRAM continues to provide RTT_PARK.
3. All devices connected to the DQ bus should be high impedance or RTT_PARK during the calibration procedure.

Figure 21 – ZQ Calibration Timing

9.15 DQ VREF Training

The DRAM internal DQ VREF specification parameters are operating voltage range, step size, VREF step time, VREF full step time and VREF valid level.

The voltage operating range specifies the minimum required VREF setting range for DDR4 DRAM devices. The minimum range is defined by VREFmax and VREFmin as depicted in Figure 22 below.

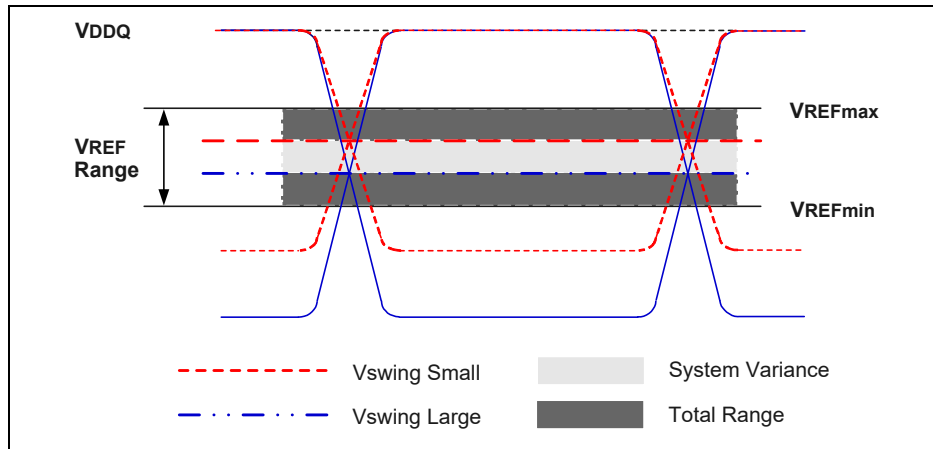

Figure 22 – VREF operating range (VREFmin, VREFmax)



The VREF step size is defined as the step size between adjacent steps. Vref step size ranges from 0.5% VDDQ to 0.8% VDDQ. However, for a given design, DRAM has one value for VREF step size that falls within the range.

The VREF set tolerance is the variation in the VREF voltage from the ideal setting. This accounts for accumulated error over multiple steps. There are two ranges for VREF set tolerance uncertainty. The range of VREF set tolerance uncertainty is a function of number of steps n.

The VREF set tolerance is measured with respect to the ideal line which is based on the two endpoints. Where the endpoints are at the min and max VREF values for a specified range. An illustration depicting an example of the step size and VREF set tolerance is below.

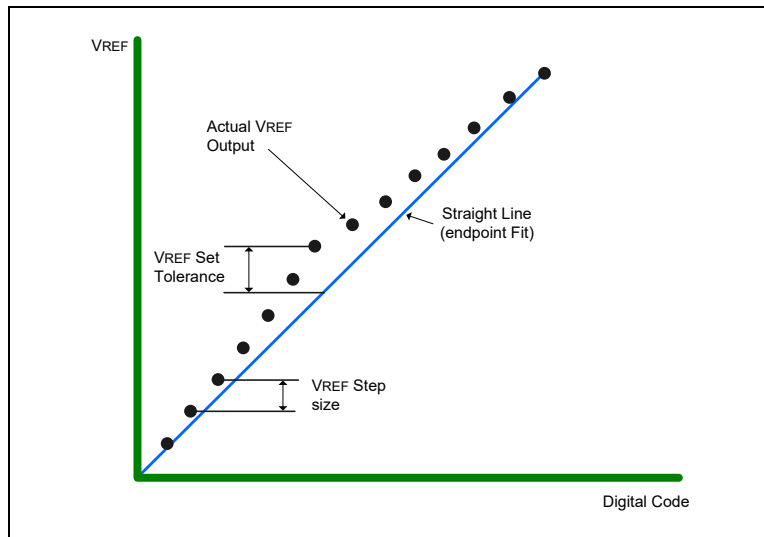

Figure 23 – Example of VREF set tolerance (max case only shown) and step size

The VREF increment/decrement step times are defined by VREF_time. The VREF_time is defined from t0 to t1 as shown in the Figure 24 below where t1 is referenced to when the VREF voltage is at the final DC level within the VREF valid tolerance (VREF_val_tol).

The VREF valid level is defined by VREF_val tolerance to qualify the step time t1 as shown in Figure 26 through Figure 29. This parameter is used to insure an adequate RC time constant behavior of the voltage level change after any VREF increment/decrement adjustment. This parameter is only applicable for DRAM component level validation/characterization.

VREF_time is the time including up to VREFmin to VREFmax or VREFmax to VREFmin change in VREF voltage.

t0 - is referenced to MRS command clock

t1 - is referenced to the VREF_val_tol

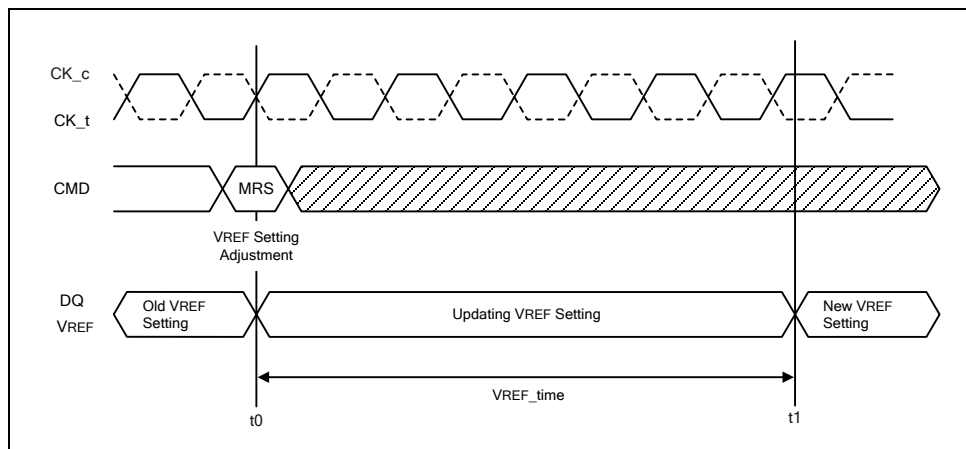

Figure 24 – VREF_time timing diagram



VREFDQ Calibration Mode is entered via MRS command setting MR6 A[7] to 1 (0 disables VREFDQ Calibration Mode), setting MR6 A[6] to either 0 or 1 to select the desired range, and MR6 A[5:0] with a “don’t care” setting. The next subsequent MR command is used to set the desired VREFDQ values at MR6 A[5:0]. Once VREFDQ Calibration Mode has been entered, VREFDQ Calibration Mode legal commands may be issued once tVREFDQE has been satisfied. VREFDQ Calibration Mode legal commands are ACT, WR, WRA, RD, RDA, PRE, DES, MRS to set VREFDQ values, and MRS to exit VREFDQ Calibration Mode. Once VREFDQ Calibration Mode has been entered, “dummy” write commands may be issued prior to adjusting VREFDQ value the first time VREFDQ calibration is performed after initialization. The “dummy” write commands may have bubbles between write commands provided other DRAM timings are satisfied. A possible example command sequence would be: WR1, DES, DES, DES, WR2, DES, DES, DES, WR3, DES, DES, DES, WR4, DES, DES.....DES, DES, WR50, DES, DES, DES. Setting VREFDQ values requires MR6 [7] set to 1, MR6 [6] unchanged from initial range selection, and MR6 A[5:0] set to desired VREFDQ value; if MR6 [7] is set to 0, MR6 [6:0] are not written. VREF_time must be satisfied after each MR6 command to set VREFDQ value before the internal VREFDQ value is valid.

If PDA mode is used in conjunction with VREFDQ calibration, the PDA mode requirement that only MRS commands are allowed while PDA mode is enabled is not waived. That is, the only VREFDQ Calibration Mode legal commands noted above that may be used are the MRS commands, i.e. MRS to set VREFDQ values, and MRS to exit VREFDQ Calibration Mode.

The last A[6:0] setting written to MR6 prior to exiting VREFDQ Calibration Mode is the range and value used for the internal VREFDQ setting. VREFDQ Calibration Mode may be exited when the DRAM is in idle state. After the MRS command to exit VREFDQ Calibration Mode has been issued, DES must be issued till tVREFDQX has been satisfied where any legal command may then be issued.

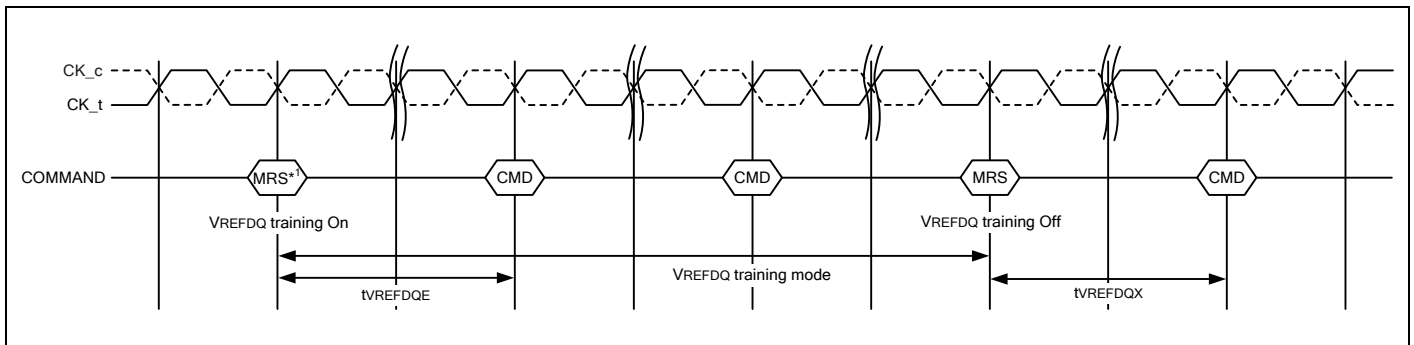

Notes:

1. The MR command used to enter VREFDQ Calibration Mode treats MR6 A[5:0] as don't care while the next subsequent MR command sets VREFDQ values in MR6 A[5:0].
2. Depending on the step size of the latest programmed VREF value, VREF_time must be satisfied before disabling VREFDQ training mode.

Figure 25 – VREFDQ training mode entry and exit timing diagram

Table 32 – AC parameters of DDR4 VREFDQ training

Speed		DDR4-1600,1866,2133,2400,2666,3200		Units	Note
Parameter	Symbol	MIN	MAX		
VREFDQ training					
Enter VREFDQ training mode to the first valid command delay	tVREFDQE	150	-	nS	
Exit VREFDQ training mode to the first valid command delay	tVREFDQX	150	-	nS	



9.15.1 Example scripts for VREFDQ Calibration Mode

When MR6 [7] = 0 then MR6 [6:0] = XXXXXXXX

Entering VREFDQ Calibration if entering range 1:

- MR6 [7:6]=10 & [5:0]=XXXXXX
- All subsequent VREFDQ Calibration MR setting commands are MR6 [7:6]=10 & MR6 [5:0]=VVVVVV
{VVVVVV are desired settings for VREFDQ}
- Issue ACT/WR/RD looking for pass/fail to determine Vcent(midpoint) as needed
- Just prior to exiting VREFDQ Calibration mode:
- Last two VREFDQ Calibration MR commands are
- MR6 [7:6]=10, MR6 [5:0]=VVVVVV' where VVVVVV' = desired value for VREFDQ
- MR6 [7]=0, MR6 [6:0]=XXXXXXX to exit VREFDQ Calibration mode

Entering VREFDQ Calibration if entering range 2:

- MR6 [7:6]=11 & [5:0]=XXXXXX
- All subsequent VREFDQ Calibration MR setting commands are MR6 [7:6]=11 & MR6 [5:0]=VVVVVV
{VVVVVV are desired settings for VREFDQ}
- Issue ACT/WR/RD looking for pass/fail to determine Vcent(midpoint) as needed
- Just prior to exiting VREFDQ Calibration mode:
- Last two VREFDQ Calibration MR commands are
- MR6 [7:6]=11, MR6 [5:0]=VVVVVV' where VVVVVV' = desired value for VREFDQ
- MR6 [7]=0, MR6 [6:0]=XXXXXXX to exit VREFDQ Calibration mode

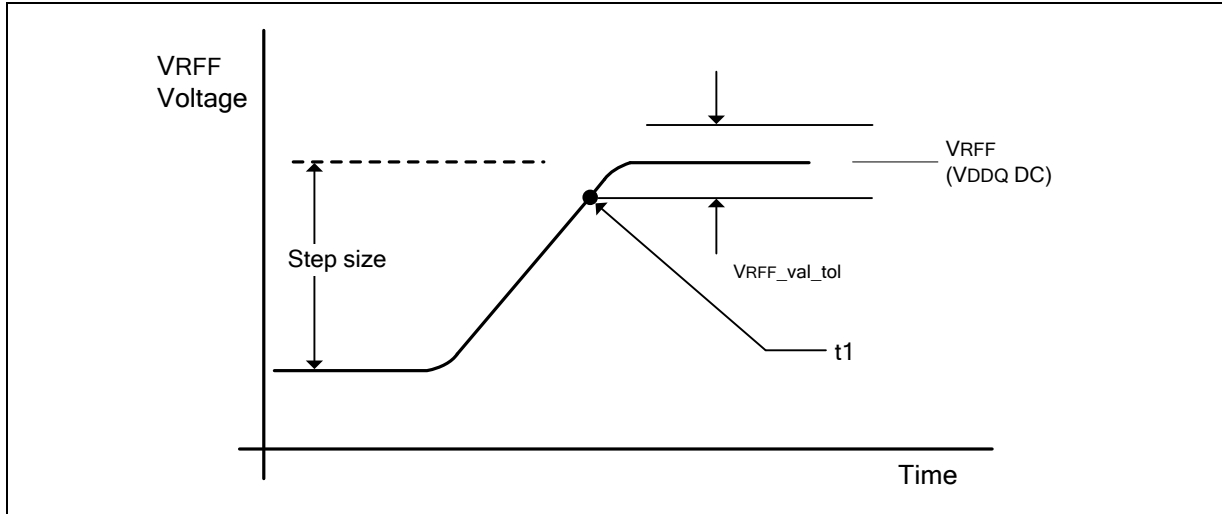

Figure 26 – VREF step single step size increment case

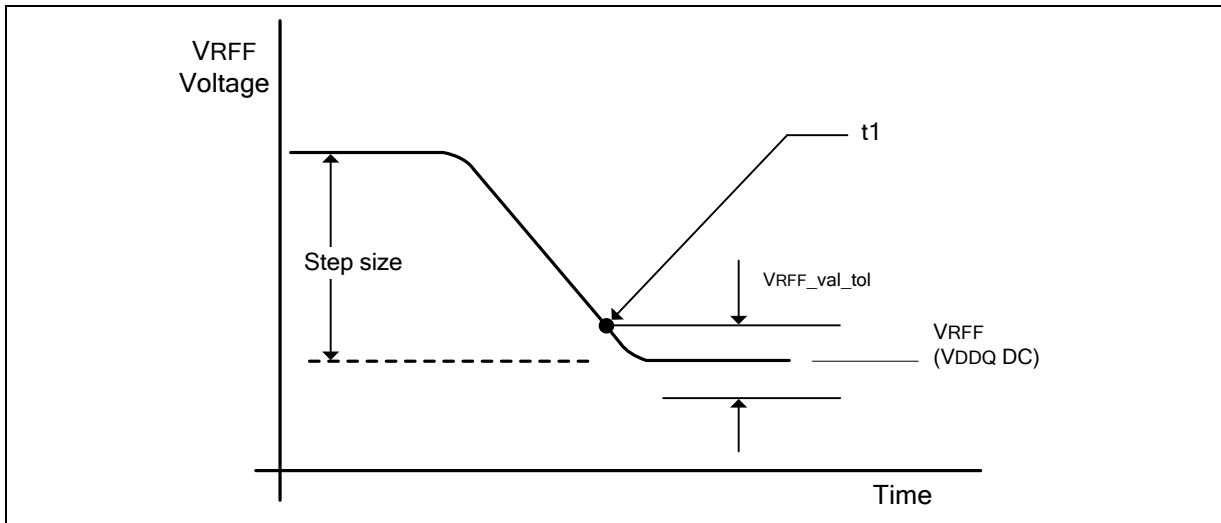

Figure 27 – VREF step single step size decrement case

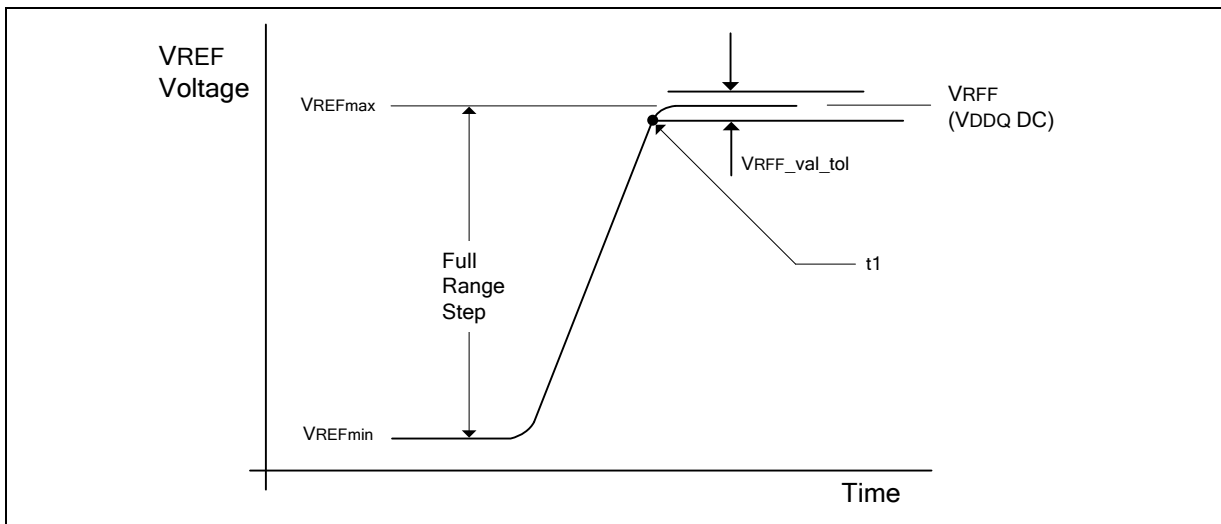

Figure 28 – VREF full step from VREFmin to VREFmax case

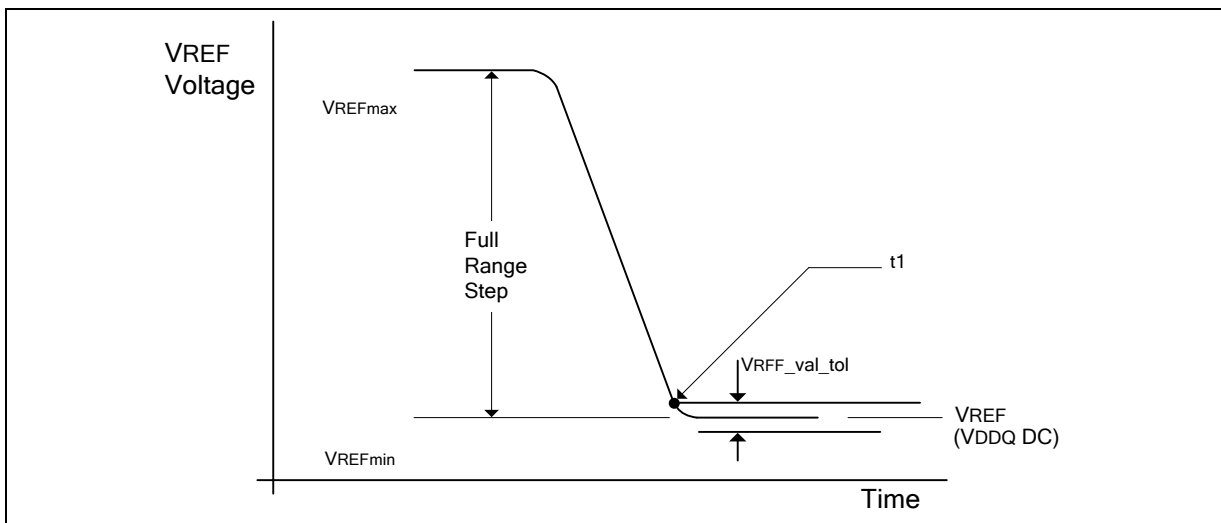

Figure 29 – VREF full step from VREFmax to VREFmin case



Table 33 – DQ Internal VREF Specifications

Parameter	Symbol	Min	Typ	Max	Unit	Notes
VREF Max operating point Range1	VREF_max_R1	92%	-	-	VDDQ	1, 10
VREF Min operating point Range1	VREF_min_R1	-	-	60%	VDDQ	1, 10
VREF Max operating point Range2	VREF_max_R2	77%	-	-	VDDQ	1, 10
VREF Min operating point Range2	VREF_min_R2	-	-	45%	VDDQ	1, 10
VREF Step size	VREF_step	0.50%	0.65%	0.80%	VDDQ	2
VREF Set Tolerance	VREF_set_tol	-1.625%	0.00%	1.625%	VDDQ	3, 4, 6
		-0.15%	0.00%	0.15%	VDDQ	3, 5, 7
VREF Step Time	VREF_time	-	-	150	nS	8, 11
VREF Valid tolerance	VREF_val_tol	-0.15%	0.00%	0.15%	VDDQ	9

Notes:

- VREF DC voltage referenced to VDDQ_DC. VDDQ_DC is 1.2V
- VREF step size increment/decrement range. VREF at DC level.
- $VREF_{new} = VREF_{old} \pm n \times VREF_{step}$; n = number of step; if increment use "+"; if decrement use "-"
- The minimum value of VREF setting tolerance = $VREF_{new} - 1.625\% \times VDDQ$. The maximum value of VREF setting tolerance = $VREF_{new} + 1.625\% \times VDDQ$. For $n > 4$
- The minimum value of VREF setting tolerance = $VREF_{new} - 0.15\% \times VDDQ$. The maximum value of VREF setting tolerance = $VREF_{new} + 0.15\% \times VDDQ$. For $n \leq 4$
- Measured by recording the min and max values of the VREF output over the range, drawing a straight line between those points and comparing all other VREF output settings to that line.
- Measured by recording the min and max values of the VREF output across 4 consecutive steps ($n = 4$), drawing a straight line between those points and comparing all other VREF output settings to that line.
- Time from MRS command to increment or decrement one step size up to full range of VREF.
- Only applicable for DRAM component level test/characterization purpose. Not applicable for normal mode of operation. VREF valid is to qualify the step times which will be characterized at the component level.
- DRAM range1 or 2 set by MRS bit MR6 A[6].
- If the VREF monitor is enabled, VREF_time must be derated by: +10nS if DQ load is 0pF and an additional +15nS/pF of DQ loading.

9.16 Per DRAM Addressability

DDR4 allows programmability of a given device on a rank. As an example, this feature can be used to program different ODT or VREF values on DRAM devices on a given rank.

- Before entering "per DRAM addressability (PDA)" mode, the write leveling is required.
- Before entering "per DRAM addressability (PDA)" mode, the following Mode Register setting is possible.
 - RTT_PARK MR5 A[8:6] = Enable
 - RTT_NOM MR1 A[10:8] = Enable
- Enable "per DRAM addressability (PDA)" mode using MR3 A[4] = "1".
- In the "per DRAM addressability (PDA)" mode, all MRS command is qualified with DQL0. DRAM captures DQL0 by using DQSL_c and DQSL_t signals as shown Figure 30. If the value on DQL0 is 0 then the DRAM executes the MRS command. If the value on DQL0 is 1, then the DRAM ignores the MRS command. The controller can choose to drive all the DQ bits.
- Program the desired devices and mode registers using MRS command and DQL0.
- In the "per DRAM addressability" mode, only MRS commands are allowed.
- The mode register set command cycle time at PDA mode, $AL + CWL + BL/2 - 0.5tCK + tMRD_{PDA} + (PL)$ is required to complete the write operation to the mode register and is the minimum time required between two MRS commands shown in Figure 30.
- Remove the DRAM from "per DRAM addressability" mode by setting MR3 A[4] = "0". (This command will require DQL0 shown in Figure 31.



Note:

Removing a DRAM from per DRAM addressability mode will require programming the entire MR3 when the MRS command is issued. This may impact some per DRAM values programmed within a rank as the exit command is sent to the rank. In order to avoid such a case, the PDA Enable/Disable Control bit is located in a mode register that does not have any “per DRAM addressability” mode controls).

In per DRAM addressability mode, DRAM captures DQL0 using DQSL_c and DQSL_t like normal write operation. However, Dynamic ODT is not supported. Extra care is required for the ODT setting. If RTT_NOM MR1 A[10:8] = Enable, DDR4 SDRAM data termination need to be controlled by ODT pin and apply the same timing parameters as defined in Direct ODT function that shown in Table 34. VREFDQ value must be set to either its midpoint or Vcent_DQ(midpoint) in order to capture DQL0 low level for entering PDA mode.

Table 34 – Applied ODT Timing Parameter to PDA Mode

Symbol	Parameter
DODTLon	Direct ODT turn on latency
DODTLoff	Direct ODT turn off latency
tADC	RTT change timing skew
tAONAS	Asynchronous RTT_NOM turn-on delay
tAOFAS	Asynchronous RTT_NOM turn-off delay

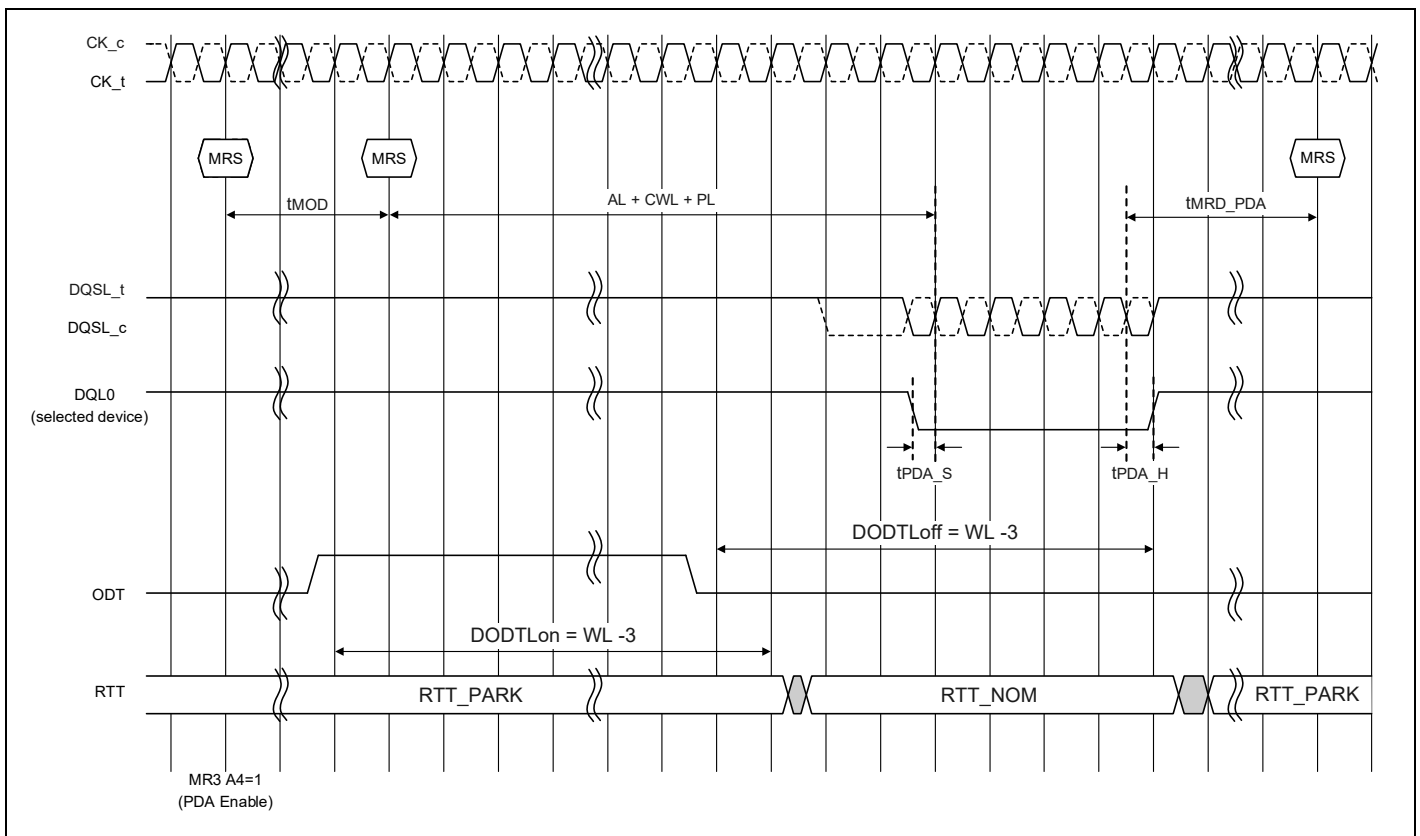

Note: RTT_PARK = Enable, RTT_NOM = Enable, Write Preamble Set = 2tCK and DLL = ON, CA parity is used

Figure 30 – MRS w/ per DRAM addressability (PDA) issuing before MRS

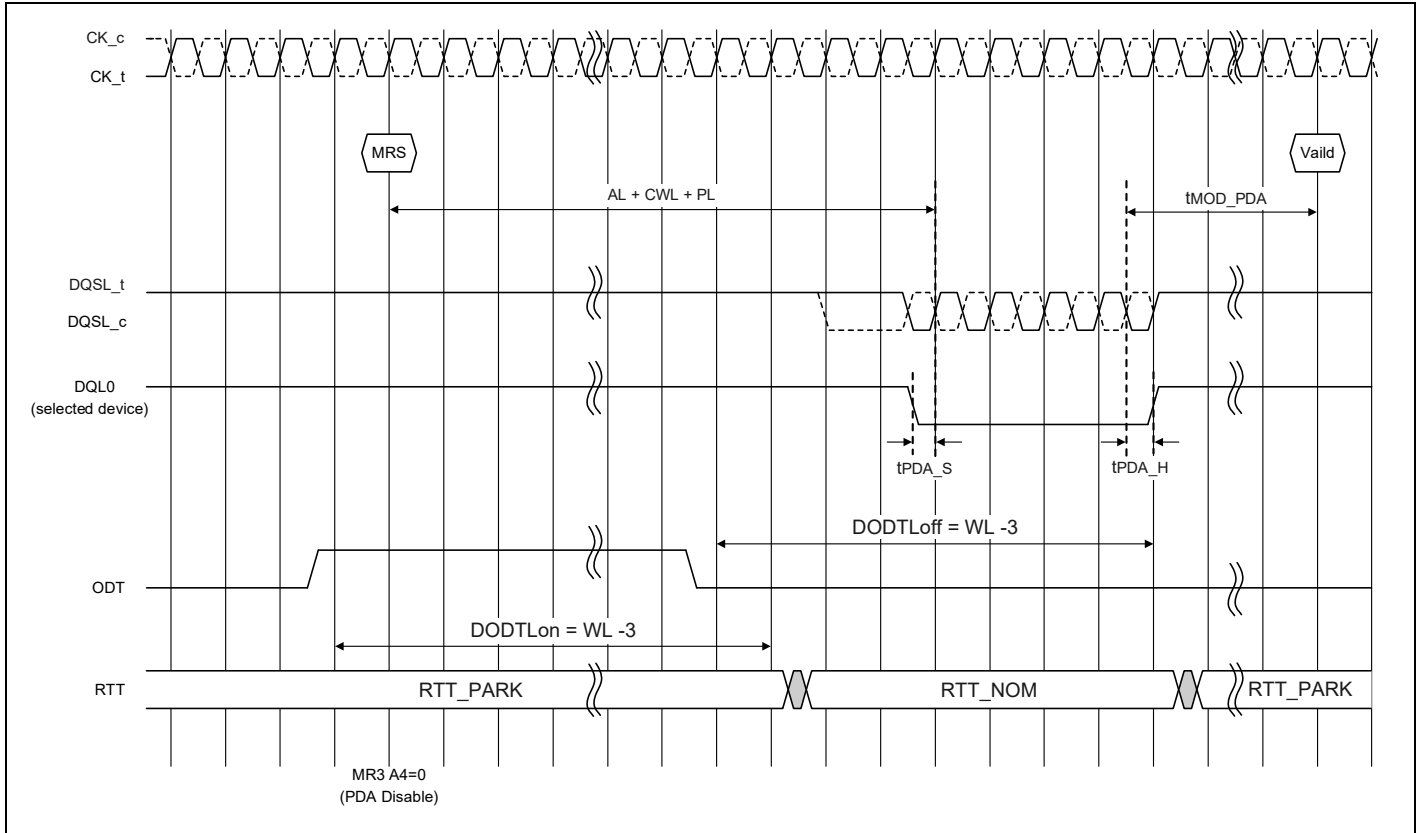

Note: RTT_PARK = Enable, RTT_NOM = Enable, Write Preamble Set = 2tCK and DLL = ON, CA parity is used

Figure 31 – MRS w/ per DRAM addressability (PDA) Exit

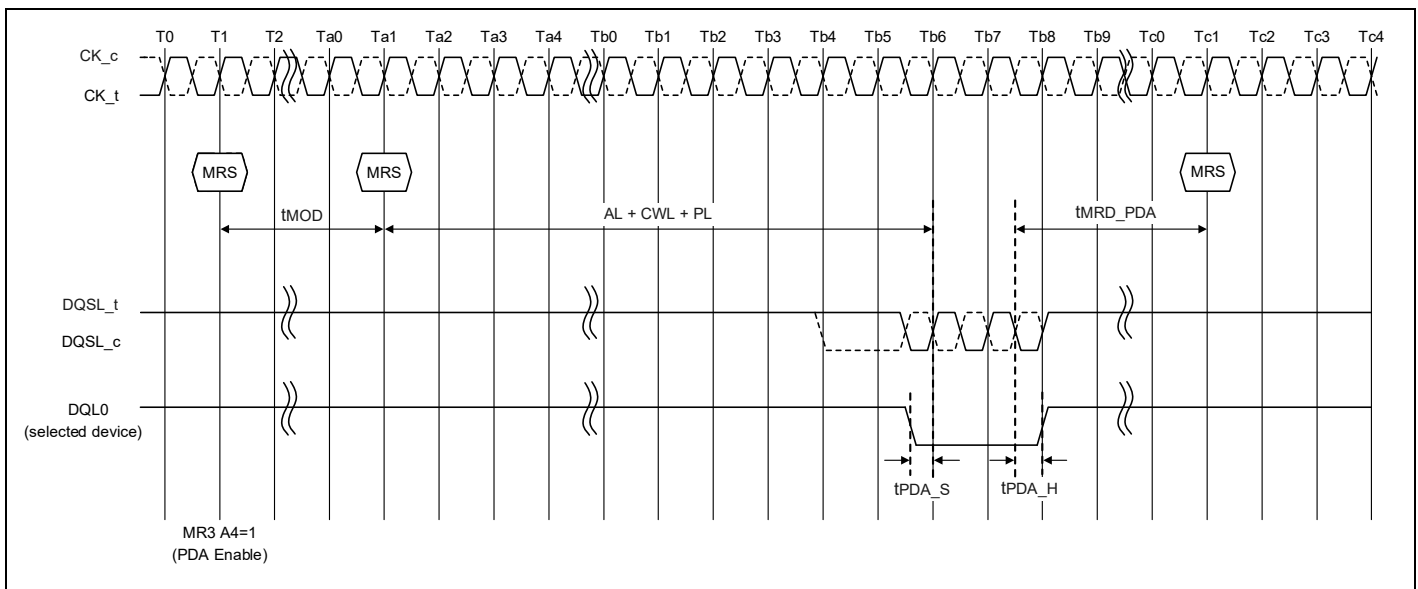

Note: RTT_PARK = Enable, RTT_NOM = Enable, Write Preamble Set = 2tCK and DLL = ON, CA parity is used

Figure 32 – PDA using Burst Chop 4

Since PDA mode may be used to program optimal VREF for the DRAM, the DRAM may incorrectly read DQ level at the first DQS edge and the last falling DQS edge. It is recommended that DRAM samples DQL0 on either the first falling or second rising DQS edges.

This will enable a common implementation between BC4 and BL8 modes on the DRAM. Controller is required to drive DQL0 to a “Stable Low or High” during the length of the data transfer for BC4 and BL8 cases.



9.17 CAL Mode (CS_n to Command Address Latency)

9.17.1 CAL Mode Description

DDR4 supports Command Address Latency, CAL function as a power savings feature. CAL is the delay in clock cycles between CS_n and CMD/ADDR defined by MR4 A[8:6] (See Figure 33).

CAL gives the DRAM time to enable the CMD/ADDR receivers before a command is issued. Once the command and the address are latched, the receivers can be disabled. For consecutive commands, the DRAM will keep the receivers enabled for the duration of the command sequence (See Figure 34).

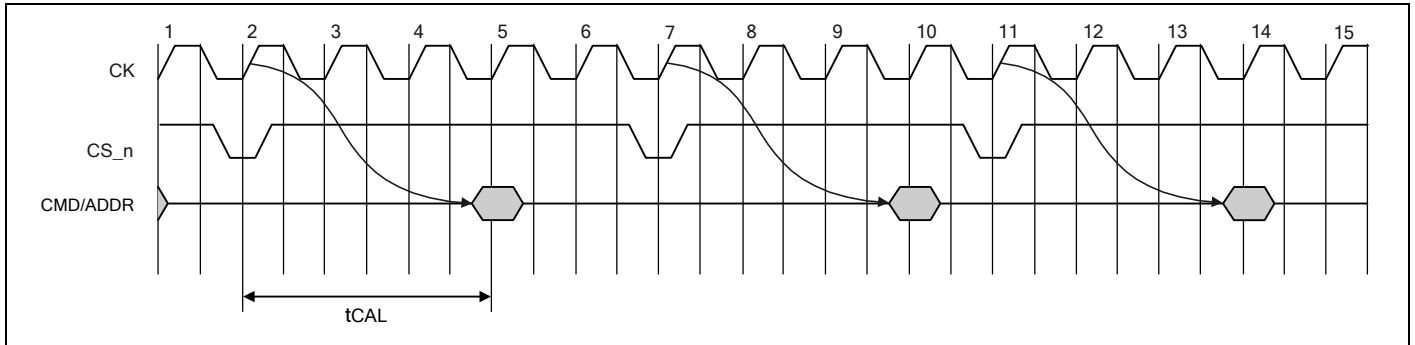

Figure 33 – Definition of CAL

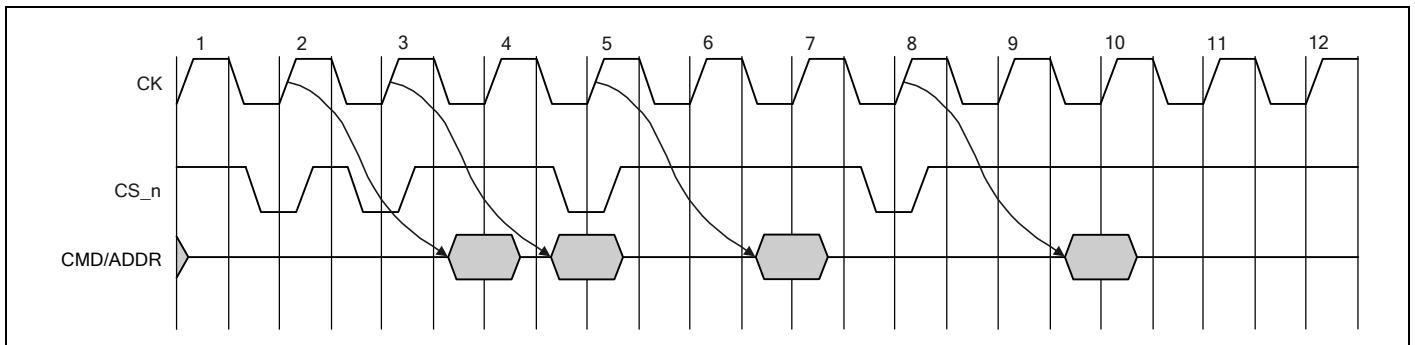

Figure 34 – CAL operational timing for consecutive command issues



The following tables show the timing requirements for tCAL (Table 35) and MRS settings (Table 36) at different data rates.

Table 35 – CS to Command Address Latency

Parameter	Symbol	DDR4-1600	DDR4-1866	DDR4-2133	DDR4-2400	Units	Note
CS to Command Address Latency	tCAL(min)	max(3 nCK, 3.748 nS)				nCK	1
Note: 1. Gear-down mode is not supported for speed bins below DDR4-2666.							

Parameter	Symbol	DDR4-2666	DDR4-3200	Units	Note
CS to Command Address Latency	tCAL(min)	max(3 nCK, 3.748 nS)		nCK	1
Note: 1. In Gear-down mode, odd nCK values for tCAL are not supported, and nCK values must be rounded up to the next higher even integer. For example, when operating at DDR4-2666, a minimum of 6 nCK is required for tCAL.					

Table 36 – MRS settings for CAL

A[8:6] @ MR4	CAL (tCK cycles)
000	Default(disable)
001	3
010	4
011	5
100	6
101	8
110	Reserved
111	Reserved

MRS Timings with Command/Address Latency enabled

When Command/Address latency mode is enabled, users must allow more time for MRS commands to take effect. When CAL mode is enabled, or being enabled by an MRS command, the earliest the next valid command can be issued is tMOD_CAL, where tMOD_CAL=tMOD+tCAL.

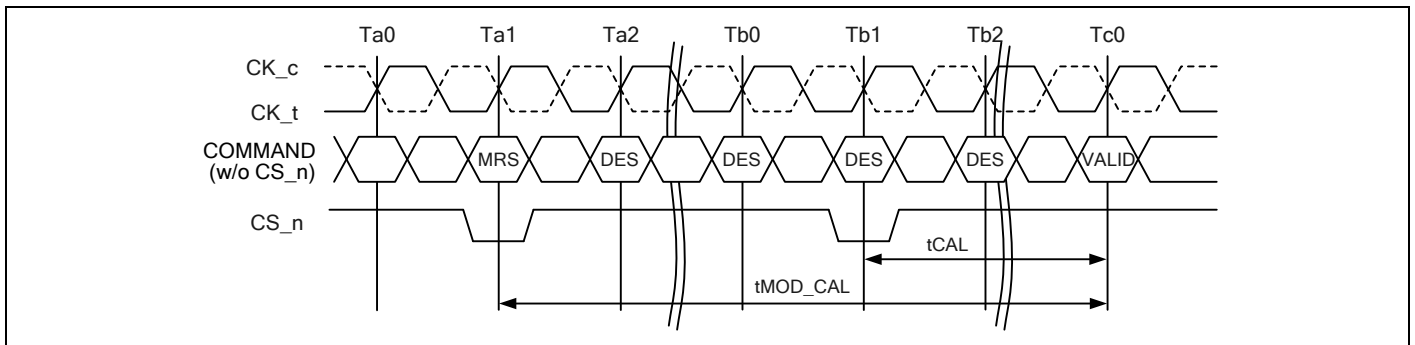

Notes:

1. MRS command at Ta1 enables CAL mode.
2. tMOD_CAL = tMOD + tCAL.

Figure 35 – CAL Enable timing - tMOD_CAL

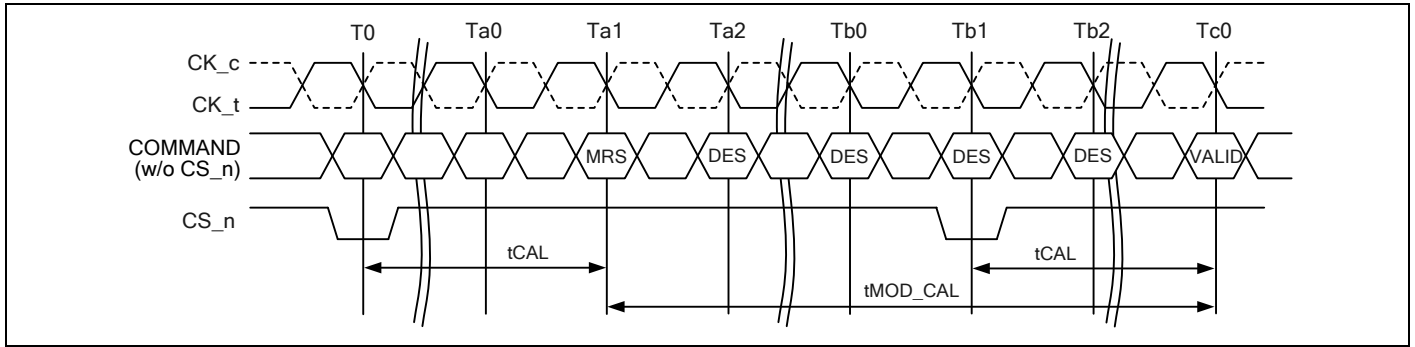

Notes:

1. MRS at Ta1 may or may not modify CAL; tMOD_CAL is computed based on new tCAL setting.
2. $tMOD_CAL = tMOD + tCAL$.

Figure 36 – tMOD_CAL, MRS to valid command timing with CAL enabled

When Command/Address latency is enabled or being entered, users must wait tMRD_CAL until the next MRS command can be issued. $tMRD_CAL = tMOD + tCAL$.

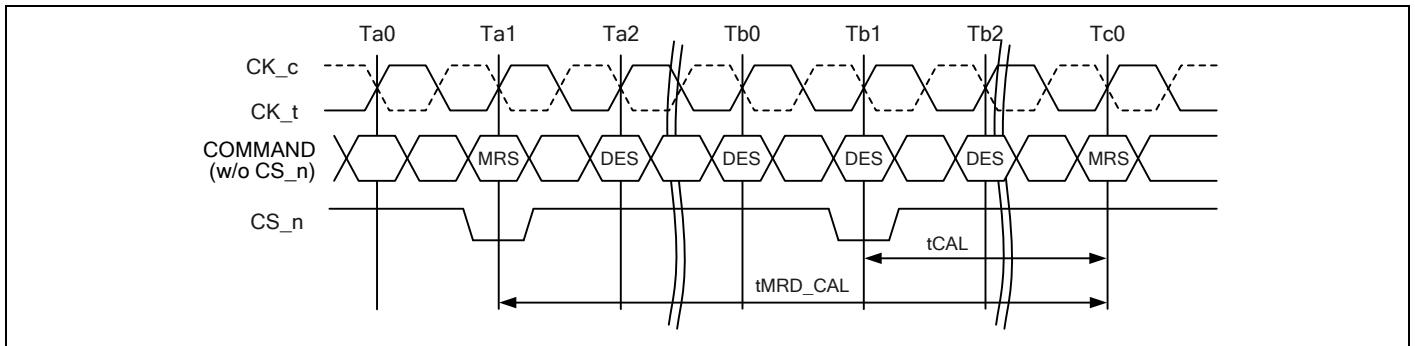

Notes:

1. MRS command at Ta1 enables CAL mode.
2. $tMRD_CAL = tMOD + tCAL$.

Figure 37 – CAL enabling MRS to next MRS command, tMRD_CAL

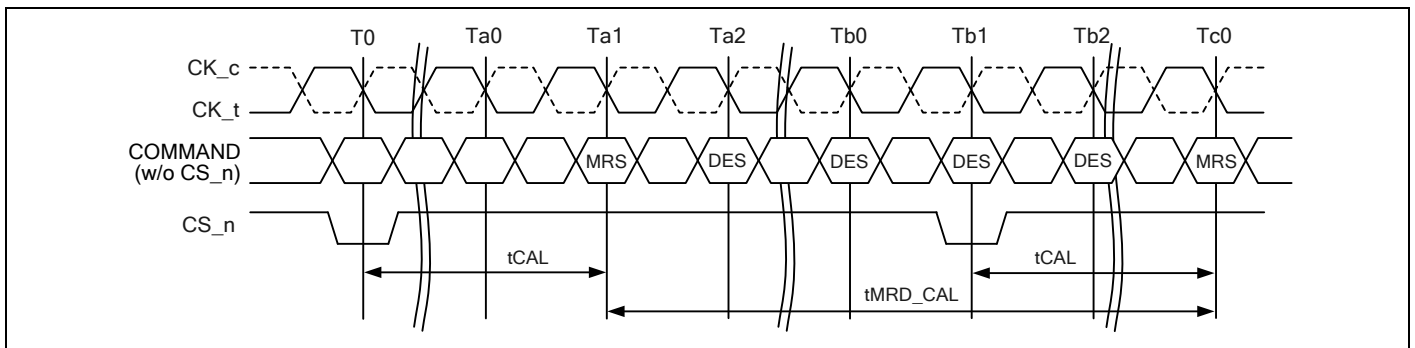

Notes:

1. MRS at Ta1 may or may not modify CAL; tMRD_CAL is computed based on new tCAL setting.
2. $tMRD_CAL = tMOD + tCAL$.

Figure 38 – tMRD_CAL, mode register cycle time with CAL enabled



9.17.2 Self Refresh Entry, Exit Timing with CAL

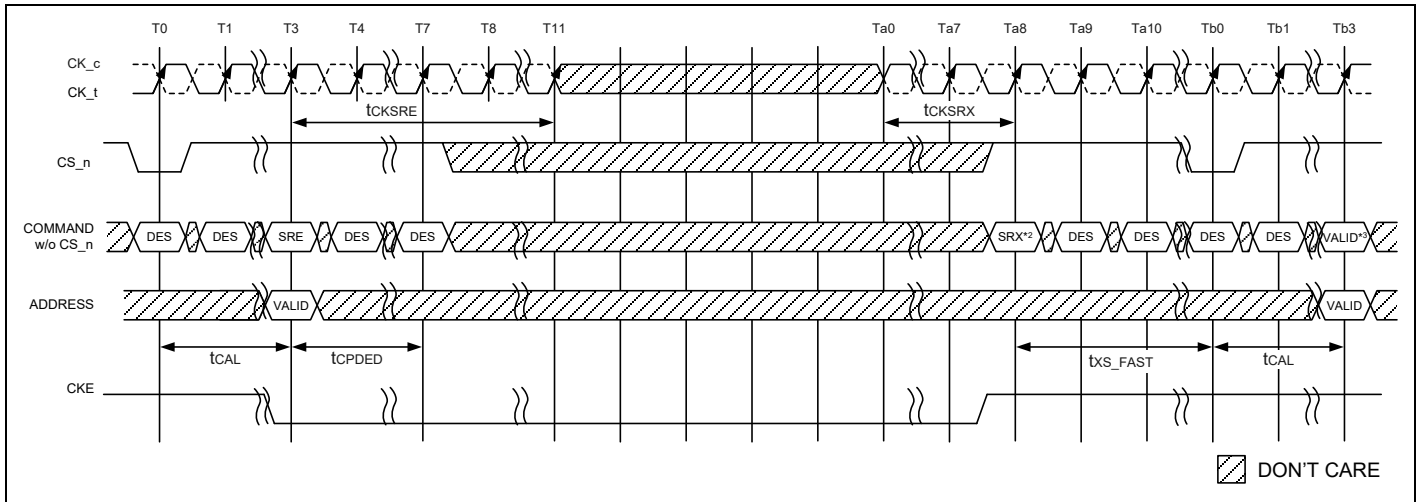

Notes:

1. $t_{CAL} = 3nCK$, $t_{CPDED} = 4nCK$, $t_{CKSRE} = 8nCK$, $t_{CKSRX} = 8nCK$, $t_{XS_FAST} = t_{RFC4(min)} + 10nS$.
2. $CS_n = H$, $ACT_n = \text{Don't Care}$, $RAS_n/A16 = \text{Don't Care}$, $CAS_n/A15 = \text{Don't Care}$, $WE_n/A14 = \text{Don't Care}$.
3. Only MRS (limited to those described in the Self-Refresh Operation section). ZQCS or ZQCL command allowed.

Figure 39 – Self Refresh Entry/Exit Timing with CAL

9.17.3 Power Down Entry, Exit Timing with CAL

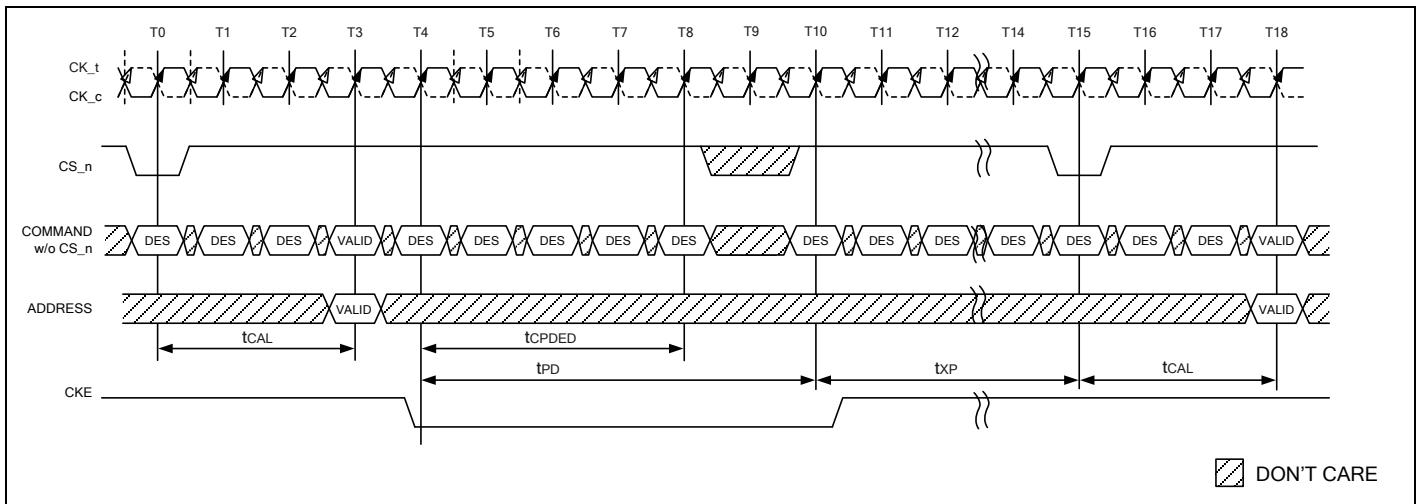

Note:

1. $t_{CAL} = 3nCK$, $t_{CPDED} = 4nCK$, $t_{PD} = 6nCK$, $t_{XP} = 5nCK$.

Figure 40 – Active Power Down Entry and Exit Timing with CAL

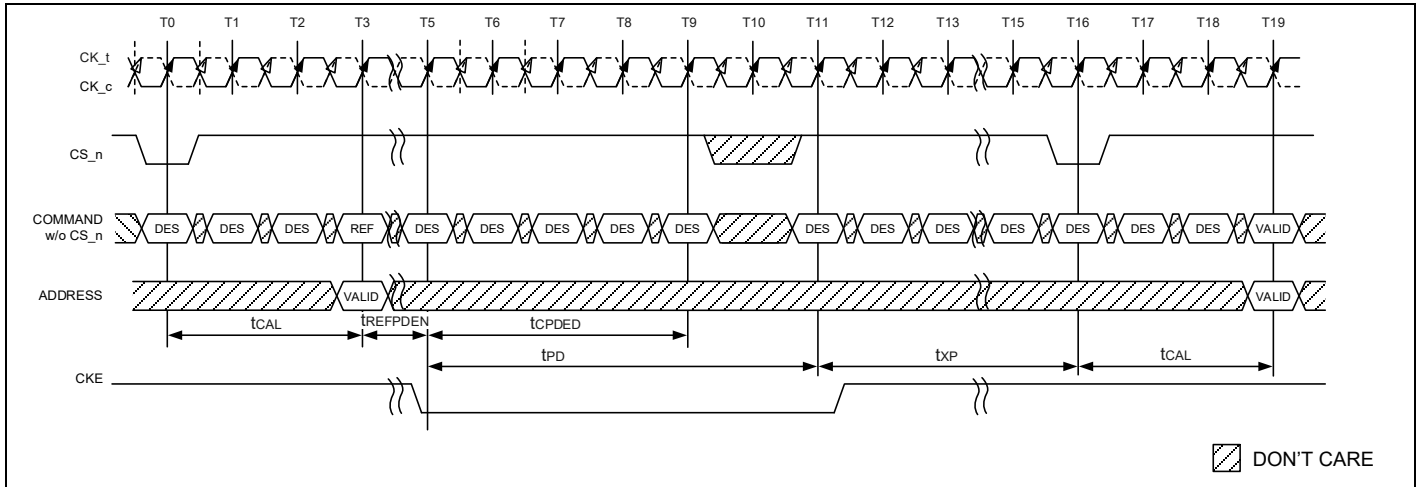

Note:

1. $t_{CAL} = 3nCK$, $t_{REFPDEN} = 2nCK$, $t_{CPDED} = 4nCK$, $t_{PD} = 6nCK$, $t_{XP} = 5nCK$.

Figure 41 – Refresh Command to Power Down Entry with CAL



9.18 CRC

9.18.1 CRC Polynomial and logic equation

DDR4 supports CRC for write operation, and doesn't support CRC for read operation.

The CRC polynomial used by DDR4 is the ATM-8 HEC, $X^8+X^2+X^1+1$

A combinatorial logic block implementation of this 8-bit CRC for 72-bits of data contains 272 two-input XOR gates contained in eight 6-XOR-gate-deep trees.

The CRC polynomial and combinatorial logic used by DDR4 is the same as used on GDDR5.

Table 37 – Error Detection Details

ERROR TYPE	DETECTION CAPABILITY
Random Single Bit Error	100%
Random Double Bit Error	100%
Random Odd Count Error	100%
Random one Multi-bit UI vertical column error detection excluding DBI bits	100%

CRC COMBINATORIAL LOGIC EQUATIONS

```

module CRC8_D72;
// polynomial: (0 1 2 8)
// data width: 72
// convention: the first serial data bit is D[71]
// initial condition all 0 implied
function [7:0]
nextCRC8_D72;
input [71:0] Data;
reg [71:0] D;
reg [7:0] NewCRC;
begin
D = Data;
NewCRC[0] = D[69] ^ D[68] ^ D[67] ^ D[66] ^ D[64] ^ D[63] ^ D[60] ^
D[56] ^ D[54] ^ D[53] ^ D[52] ^ D[50] ^ D[49] ^ D[48] ^
D[45] ^ D[43] ^ D[40] ^ D[39] ^ D[35] ^ D[34] ^ D[31] ^
D[30] ^ D[28] ^ D[23] ^ D[21] ^ D[19] ^ D[18] ^ D[16] ^
D[14] ^ D[12] ^ D[8] ^ D[7] ^ D[6] ^ D[0];
NewCRC[1] = D[70] ^ D[66] ^ D[65] ^ D[63] ^ D[61] ^ D[60] ^ D[57] ^
D[56] ^ D[55] ^ D[52] ^ D[51] ^ D[48] ^ D[46] ^ D[45] ^
D[44] ^ D[43] ^ D[41] ^ D[39] ^ D[36] ^ D[34] ^ D[32] ^
D[30] ^ D[29] ^ D[28] ^ D[24] ^ D[23] ^ D[22] ^ D[21] ^
D[20] ^ D[18] ^ D[17] ^ D[16] ^ D[15] ^ D[14] ^ D[13] ^
D[12] ^ D[9] ^ D[6] ^ D[1] ^ D[0];
NewCRC[2] = D[71] ^ D[69] ^ D[68] ^ D[63] ^ D[62] ^ D[61] ^ D[60] ^
D[58] ^ D[57] ^ D[54] ^ D[50] ^ D[48] ^ D[47] ^ D[46] ^
D[44] ^ D[43] ^ D[42] ^ D[39] ^ D[37] ^ D[34] ^ D[33] ^
D[29] ^ D[28] ^ D[25] ^ D[24] ^ D[22] ^ D[17] ^ D[15] ^
D[13] ^ D[12] ^ D[10] ^ D[8] ^ D[6] ^ D[2] ^ D[1] ^ D[0];
NewCRC[3] = D[70] ^ D[69] ^ D[64] ^ D[63] ^ D[62] ^ D[61] ^ D[59] ^
D[58] ^ D[55] ^ D[51] ^ D[49] ^ D[48] ^ D[47] ^ D[45] ^
D[44] ^ D[43] ^ D[40] ^ D[38] ^ D[35] ^ D[34] ^ D[30] ^
D[29] ^ D[26] ^ D[25] ^ D[23] ^ D[18] ^ D[16] ^ D[14] ^
D[13] ^ D[11] ^ D[9] ^ D[7] ^ D[3] ^ D[2] ^ D[1];
NewCRC[4] = D[71] ^ D[70] ^ D[65] ^ D[64] ^ D[63] ^ D[62] ^ D[60] ^
D[59] ^ D[56] ^ D[52] ^ D[50] ^ D[49] ^ D[48] ^ D[46] ^
D[45] ^ D[44] ^ D[41] ^ D[39] ^ D[36] ^ D[35] ^ D[31] ^
D[30] ^ D[27] ^ D[26] ^ D[24] ^ D[19] ^ D[17] ^ D[15] ^
D[14] ^ D[12] ^ D[10] ^ D[8] ^ D[4] ^ D[3] ^ D[2];

```



$$\begin{aligned} \text{NewCRC}[5] &= D[71] \wedge D[66] \wedge D[65] \wedge D[64] \wedge D[63] \wedge D[61] \wedge D[60] \wedge \\ &D[57] \wedge D[53] \wedge D[51] \wedge D[50] \wedge D[49] \wedge D[47] \wedge D[46] \wedge \\ &D[45] \wedge D[42] \wedge D[40] \wedge D[37] \wedge D[36] \wedge D[32] \wedge D[31] \wedge \\ &D[28] \wedge D[27] \wedge D[25] \wedge D[20] \wedge D[18] \wedge D[16] \wedge D[15] \wedge \\ &D[13] \wedge D[11] \wedge D[9] \wedge D[5] \wedge D[4] \wedge D[3]; \\ \text{NewCRC}[6] &= D[67] \wedge D[66] \wedge D[65] \wedge D[64] \wedge D[62] \wedge D[61] \wedge D[58] \wedge \\ &D[54] \wedge D[52] \wedge D[51] \wedge D[50] \wedge D[48] \wedge D[47] \wedge D[46] \wedge \\ &D[43] \wedge D[41] \wedge D[38] \wedge D[37] \wedge D[33] \wedge D[32] \wedge D[29] \wedge \\ &D[28] \wedge D[26] \wedge D[21] \wedge D[19] \wedge D[17] \wedge D[16] \wedge D[14] \wedge \\ &D[12] \wedge D[10] \wedge D[6] \wedge D[5] \wedge D[4]; \\ \text{NewCRC}[7] &= D[68] \wedge D[67] \wedge D[66] \wedge D[65] \wedge D[63] \wedge D[62] \wedge D[59] \wedge \\ &D[55] \wedge D[53] \wedge D[52] \wedge D[51] \wedge D[49] \wedge D[48] \wedge D[47] \wedge \\ &D[44] \wedge D[42] \wedge D[39] \wedge D[38] \wedge D[34] \wedge D[33] \wedge D[30] \wedge \\ &D[29] \wedge D[27] \wedge D[22] \wedge D[20] \wedge D[18] \wedge D[17] \wedge D[15] \wedge \\ &D[13] \wedge D[11] \wedge D[7] \wedge D[6] \wedge D[5]; \end{aligned}$$

nextCRC8_D72 = NewCRC;

9.18.2 CRC data bit mapping for x16 device with BL8

A x16 device have two identical CRC trees implemented. CRC[7:0] covers data bits d[71:0]. CRC[15:8] covers data bits d[143:72].

	0	1	2	3	4	5	6	7	8	9
DQ0	d0	d1	d2	d3	d4	d5	d6	d7	CRC0	1
DQ1	d8	d9	d10	d11	d12	d13	d14	d15	CRC1	1
DQ2	d16	d17	d18	d19	d20	d21	d22	d23	CRC2	1
DQ3	d24	d25	d26	d27	d28	d29	d30	d31	CRC3	1
DQ4	d32	d33	d34	d35	d36	d37	d38	d39	CRC4	1
DQ5	d40	d41	d42	d43	d44	d45	d46	d47	CRC5	1
DQ6	d48	d49	d50	d51	d52	d53	d54	d55	CRC6	1
DQ7	d56	d57	d58	d59	d60	d61	d62	d63	CRC7	1
DML_n/ DBIL_n	d64	d65	d66	d67	d68	d59	d70	d71	1	1
DQ8	d72	d73	d74	d75	d76	d77	d78	d79	CRC8	1
DQ9	d80	d81	d82	d83	d84	d85	d86	d87	CRC9	1
DQ10	d88	d89	d90	d91	d92	d93	d94	d95	CRC10	1
DQ11	d96	d97	d98	d99	d100	d101	d102	d103	CRC11	1
DQ12	d104	d105	d106	d107	d108	d109	d110	d111	CRC12	1
DQ13	d112	d113	d114	d115	d116	d117	d118	d119	CRC13	1
DQ14	d120	d121	d122	d123	d124	d125	d126	d127	CRC14	1
DQ15	d128	d129	d130	d131	d132	d133	d134	d135	CRC15	1
DMU_n/ DBIU_n	d136	d37	d138	d139	d140	d141	d142	d143	1	1



9.18.3 Write CRC for x16 device

The Controller generates the CRC checksum and forms the write data frames as shown in section 9.18.1 to section 9.18.2.

For a x16 DRAM the controller must send 1's in the transfer 9 if CRC is enabled and must send 1's in transfer 8 and transfer 9 of the DBIL_n and DBIU_n lanes if DBI function is enabled.

The DRAM checks for an error in a received code word d[71:0] by comparing the received checksum against the computed checksum and reports errors using the ALERT_n signal if there is a mis-match.

A x16 device has two identical CRC trees with 72 input bits each. The upper 8 bits are used if either Write DBI or DM is enabled. Note that Write DBI and DM function cannot be enabled simultaneously. If both Write DBI and DM is disabled then the inputs of the upper 8 bits d[143:136] and d[71:64] are "1"s.

DRAM can write data to the DRAM core without waiting for CRC check for full writes. If bad data is written to the DRAM core then controller will retry the transaction and overwrite the bad data. Controller is responsible for data coherency.

9.18.4 CRC Error Handling

CRC Error mechanism shares the same Alert_n signal for reporting errors on writes to DRAM. The controller has no way to distinguish between CRC errors and Command/Address/Parity errors other than to read the DRAM mode registers. This is a very time consuming process in a multi-rank configuration.

To speed up recovery for CRC errors, CRC errors are only sent back as a pulse. The minimum pulse-width is six clocks. The latency to Alert_n signal is defined as tCRC_ALERT in the figure below.

DRAM will set CRC Error Clear bit in A3 of MR5 to "1" and CRC Error Status bit in MPR3 of page1 to "1" upon detecting a CRC error. The CRC Error Clear bit remains set at "1" until the host clears it explicitly using an MRS command.

The controller upon seeing an error as a pulse width will retry the write transactions. The controller understands the worst case delay for Alert_n (during initialization) and can back up the transactions accordingly or the controller can be made more intelligent and tries to correlate the write CRC error to a specific rank or a transaction. The controller is also responsible for opening any pages and ensuring that retrying of writes is done in a coherent fashion.

The pulse width may be seen longer than six clocks at the controller if there are multiple CRC errors as the Alert_n is a daisy chain bus.

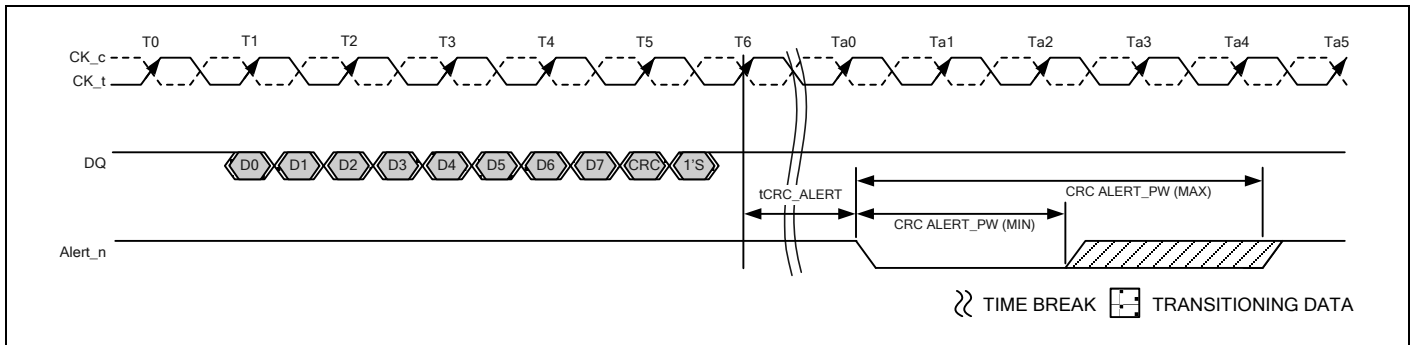

Note:

1. CRC ALERT_PW is specified from the point where the DRAM starts to drive the signal low to the point where the DRAM driver releases and the controller starts to pull the signal up.

Figure 42 – CRC Error Reporting

Table 38 – CRC Error Timing Parameters

		DDR4-1600,1866,2133,2400,2666,3200		Unit
Parameter	Symbol	min	max	
CRC error to ALERT_n latency	tCRC_ALERT	3	13	nS
CRC ALERT_n pulse width	CRC ALERT_PW	6	10	nCK



9.18.5 CRC Frame format with BC4

DDR4 SDRAM supports CRC function for Write operation for Burst Chop 4 (BC4). The CRC function is programmable using DRAM mode register and can be enabled for writes.

When CRC is enabled the data frame length is fixed at 10UI for both BL8 and BC4 operations. DDR4 SDRAM also supports burst length on the fly with CRC enabled. This is enabled using mode register.

DBI and CRC clarification

Write operation: The SDRAM computes the CRC for received data d[71:0]. Data is not inverted based on DBI before it is used for computing CRC. The data is inverted based on DBI before it is written to the DRAM core.

Burst Ordering with BC4 and CRC enabled

If CRC is enabled then address bit A2 is used to transfer critical data first for BC4 writes.

CRC data bit mapping for x16 device (BC4)

The following table shows detailed bit mapping for a x16 device. (BC4, A2=0)

	Transfer									
	0	1	2	3	4	5	6	7	8	9
DQ0	d0	d1	d2	d3	1	1	1	1	CRC0	1
DQ1	d8	d9	d10	d11	1	1	1	1	CRC1	1
DQ2	d16	d17	d18	d19	1	1	1	1	CRC2	1
DQ3	d24	d25	d26	d27	1	1	1	1	CRC3	1
DQ4	d32	d33	d34	d35	1	1	1	1	CRC4	1
DQ5	d40	d41	d42	d43	1	1	1	1	CRC5	1
DQ6	d48	d49	d50	d51	1	1	1	1	CRC6	1
DQ7	d56	d57	d58	d59	1	1	1	1	CRC7	1
DML_n/ DBIL_n	d64	d65	d66	d67	1	1	1	1	1	1
DQ8	d72	d73	d74	d75	1	1	1	1	CRC8	1
DQ9	d80	d81	d82	d83	1	1	1	1	CRC9	1
DQ10	d88	d89	d90	d91	1	1	1	1	CRC10	1
DQ11	d96	d97	d98	d99	1	1	1	1	CRC11	1
DQ12	d104	d105	d106	d107	1	1	1	1	CRC12	1
DQ13	d112	d113	d114	d115	1	1	1	1	CRC13	1
DQ14	d120	d121	d122	d123	1	1	1	1	CRC14	1
DQ15	d128	d129	d130	d131	1	1	1	1	CRC15	1
DMU_n/ DBIU_n	d136	d137	d138	d139	1	1	1	1	1	1

For a x16 SDRAM there are two identical CRC trees.

The lower CRC tree inputs have 36 bits as shown as above table. The input bits d[67:64] are used if DBIL_n or DML_n functions are enabled. If DBIL_n or DML_n are disabled then d[67:64] are "1".

The upper CRC tree inputs have 36 bits as shown as above table. The input bits d[139:136] are used if DBIU_n or DMU_n functions are enabled. If DBIU_n or DMU_n are disabled then d[139:136] are "1".



The following table shows detailed bit mapping for a x16 device. (BC4, A2=1)

	Transfer									
	0	1	2	3	4	5	6	7	8	9
DQ0	d4	d5	d6	d7	1	1	1	1	CRC0	1
DQ1	d12	d13	d14	d15	1	1	1	1	CRC1	1
DQ2	d20	d21	d22	d23	1	1	1	1	CRC2	1
DQ3	d28	d29	d30	d31	1	1	1	1	CRC3	1
DQ4	d36	d37	d38	d39	1	1	1	1	CRC4	1
DQ5	d44	d45	d46	d47	1	1	1	1	CRC5	1
DQ6	d52	d53	d54	d55	1	1	1	1	CRC6	1
DQ7	d60	d61	d62	d63	1	1	1	1	CRC7	1
DML_n DBIL_n	d68	d59	d70	d71	1	1	1	1	1	1
DQ8	d76	d77	d78	d79	1	1	1	1	CRC8	1
DQ9	d84	d85	d86	d87	1	1	1	1	CRC9	1
DQ10	d92	d93	d94	d95	1	1	1	1	CRC10	1
DQ11	d100	d101	d102	d103	1	1	1	1	CRC11	1
DQ12	d108	d109	d110	d111	1	1	1	1	CRC12	1
DQ13	d116	d117	d118	d119	1	1	1	1	CRC13	1
DQ14	d124	d125	d126	d127	1	1	1	1	CRC14	1
DQ15	d132	d133	d134	d135	1	1	1	1	CRC15	1
DMU_n DBIU_n	d140	d141	d142	d143	1	1	1	1	1	1

The lower CRC tree inputs have 36 bits as shown as above table. Data bits d[7:4] are used as inputs for d[3:0], d[15:12] are used as inputs to d[11:8] and so forth for the CRC tree. Input bits D[71:68] are used if DBIL_n or DML_n functions are enabled. If DBIL_n or DML_n are disabled then d[71:68] are "1"s. If A2=1 then data bits d[71:68] are used as inputs for d[67:64].

The upper CRC tree inputs have 36 bits as shown as above table. The input bits d[143:140] are used if DBIU_n or DMU_n functions are enabled. If DBIU_n or DMU_n are disabled then d[143:140] are "1". If A2=1 then data bits d[143:140] are used as inputs for d[139:136].



CRC Equations for x8 Device in BC4 mode with A2 = 0 and A2 = 1

The following example is of a CRC tree when x8 is used in BC4 mode (x16 CRC trees have similar differences).

CRC equations for x8 device in BC4 mode with A2=0 are as follows:

$$\begin{aligned}
 \text{CRC}[0] &= D[69]=1 \wedge D[68]=1 \wedge D[67] \wedge D[66] \wedge D[64] \wedge D[63]=1 \wedge D[60]=1 \wedge D[56] \wedge D[54]=1 \wedge D[53]=1 \wedge D[52]=1 \wedge D[50] \wedge D[49] \wedge \\
 &D[48] \wedge D[45]=1 \wedge D[43] \wedge D[40] \wedge D[39]=1 \wedge D[35] \wedge D[34] \wedge D[31]=1 \wedge D[30]=1 \wedge D[28]=1 \wedge D[23]=1 \wedge D[21]=1 \wedge D[19] \\
 &\wedge D[18] \wedge D[16] \wedge D[14]=1 \wedge D[12]=1 \wedge D[8] \wedge D[7]=1 \wedge D[6] =1 \wedge D[0] ; \\
 \text{CRC}[1] &= D[70]=1 \wedge D[66] \wedge D[65] \wedge D[63]=1 \wedge D[61]=1 \wedge D[60]=1 \wedge D[57] \wedge D[56] \wedge D[55]=1 \wedge D[52]=1 \wedge D[51] \wedge D[48] \wedge D[46]=1 \wedge \\
 &D[45]=1 \wedge D[44]=1 \wedge D[43] \wedge D[41] \wedge D[39]=1 \wedge D[36]=1 \wedge D[34] \wedge D[32] \wedge D[30]=1 \wedge D[29]=1 \wedge D[28]=1 \wedge D[24] \wedge D[23]=1 \\
 &\wedge D[22]=1 \wedge D[21]=1 \wedge D[20]=1 \wedge D[18] \wedge D[17] \wedge D[16] \wedge D[15]=1 \wedge D[14]=1 \wedge D[13]=1 \wedge D[12]=1 \wedge D[9] \wedge D[6]=1 \wedge D[1] \wedge D[0]; \\
 \text{CRC}[2] &= D[71]=1 \wedge D[69]=1 \wedge D[68]=1 \wedge D[63]=1 \wedge D[62]=1 \wedge D[61]=1 \wedge D[60]=1 \wedge D[58] \wedge D[57] \wedge D[54]=1 \wedge D[50] \wedge D[48] \wedge \\
 &D[47]=1 \wedge D[46]=1 \wedge D[44]=1 \wedge D[43] \wedge D[42] \wedge D[39]=1 \wedge D[37]=1 \wedge D[34] \wedge D[33] \wedge \\
 &D[29]=1 \wedge D[28]=1 \wedge D[25] \wedge D[24] \wedge D[22]=1 \wedge D[17] \wedge D[15]=1 \wedge D[13]=1 \wedge D[12]=1 \wedge D[10] \wedge D[8] \wedge D[6]=1 \wedge D[2] \wedge \\
 &D[1] \\
 &\wedge D[0]; \\
 \text{CRC}[3] &= D[70]=1 \wedge D[69]=1 \wedge D[64] \wedge D[63]=1 \wedge D[62]=1 \wedge D[61]=1 \wedge D[59] \wedge D[58] \wedge D[55]=1 \wedge D[51] \wedge D[49] \wedge D[48] \wedge D[47]=1 \wedge \\
 &D[45]=1 \wedge D[44]=1 \wedge D[43] \wedge D[40] \wedge D[38]=1 \wedge D[35] \wedge D[34] \wedge D[30]=1 \wedge D[29]=1 \wedge D[26] \wedge D[25] \wedge D[23]=1 \wedge D[18] \wedge \\
 &D[16] \wedge D[14]=1 \wedge D[13]=1 \wedge D[11] \wedge D[9] \wedge D[7]=1 \wedge D[3] \wedge D[2] \wedge D[1]; \\
 \text{CRC}[4] &= D[71]=1 \wedge D[70]=1 \wedge D[65] \wedge D[64] \wedge D[63]=1 \wedge D[62]=1 \wedge D[60]=1 \wedge D[59] \wedge D[56] \wedge D[52]=1 \wedge D[50] \wedge D[49] \wedge D[48] \wedge \\
 &D[46]=1 \wedge D[45]=1 \wedge D[44]=1 \wedge D[41] \wedge D[39]=1 \wedge D[36]=1 \wedge D[35] \wedge D[31]=1 \wedge \\
 &D[30]=1 \wedge D[27] \wedge D[26] \wedge D[24] \wedge D[19] \wedge D[17] \wedge D[15]=1 \wedge D[14]=1 \wedge D[12]=1 \wedge D[10] \wedge D[8] \wedge D[4]=1 \wedge D[3] \wedge D[2]; \\
 \text{CRC}[5] &= D[71]=1 \wedge D[66] \wedge D[65] \wedge D[64] \wedge D[63]=1 \wedge D[61]=1 \wedge D[60]=1 \wedge D[57] \wedge D[53]=1 \wedge D[51] \wedge D[50] \wedge D[49] \wedge D[47]=1 \wedge \\
 &D[46]=1 \wedge D[45]=1 \wedge D[42] \wedge D[40] \wedge D[37]=1 \wedge D[36]=1 \wedge D[32] \wedge D[31]=1 \wedge D[28]=1 \wedge D[27] \wedge D[25] \wedge D[20]=1 \wedge D[18] \\
 &\wedge D[16] \wedge D[15]=1 \wedge D[13]=1 \wedge D[11] \wedge D[9] \wedge D[5]=1 \wedge D[4]=1 \wedge D[3]; \\
 \text{CRC}[6] &= D[67] \wedge D[66] \wedge D[65] \wedge D[64] \wedge D[62]=1 \wedge D[61]=1 \wedge D[58] \wedge D[54]=1 \wedge D[52]=1 \wedge D[51] \wedge D[50] \wedge D[48] \wedge D[47]=1 \wedge \\
 &D[46]=1 \wedge D[43] \wedge D[41] \wedge D[38]=1 \wedge D[37]=1 \wedge D[33] \wedge D[32] \wedge D[29]=1 \wedge D[28]=1 \wedge D[26] \wedge D[21]=1 \wedge D[19] \wedge D[17] \wedge \\
 &D[16] \wedge D[14]=1 \wedge D[12]=1 \wedge D[10] \wedge D[6]=1 \wedge D[5]=1 \wedge D[4]=1; \\
 \text{CRC}[7] &= D[68]=1 \wedge D[67] \wedge D[66] \wedge D[65] \wedge D[63]=1 \wedge D[62]=1 \wedge D[59] \wedge D[55]=1 \wedge D[53]=1 \wedge D[52]=1 \wedge D[51] \wedge D[49] \wedge D[48] \wedge \\
 &D[47]=1 \wedge D[44]=1 \wedge D[42] \wedge D[39]=1 \wedge D[38]=1 \wedge D[34] \wedge D[33] \wedge D[30]=1 \wedge D[29]=1 \wedge D[27] \wedge D[22]=1 \wedge D[20]=1 \wedge D[18] \\
 &\wedge D[17] \wedge D[15] =1 \wedge D[13]=1 \wedge D[11] \wedge D[7]=1 \wedge D[6]=1 \wedge D[5]=1;
 \end{aligned}$$

CRC equations for x8 device in BC4 mode with A2=1 are as follows:

$$\begin{aligned}
 \text{CRC}[0] &= 1 \wedge 1 \wedge D[71] \wedge D[70] \wedge D[68] \wedge 1 \wedge 1 \wedge D[60] \wedge 1 \wedge 1 \wedge 1 \wedge D[54] \wedge D[53] \wedge D[52] \wedge 1 \wedge D[47] \wedge D[44] \wedge 1 \wedge D[39] \wedge D[38] \wedge \\
 &1 \wedge 1 \wedge 1 \wedge 1 \wedge D[23] \wedge D[22] \wedge D[20] \wedge 1 \wedge 1 \wedge D[12] \wedge 1 \wedge 1 \wedge D[4]; \\
 \text{CRC}[1] &= 1 \wedge D[70] \wedge D[69] \wedge 1 \wedge 1 \wedge 1 \wedge D[61] \wedge D[60] \wedge 1 \wedge 1 \wedge 1 \wedge D[55] \wedge D[52] \wedge 1 \wedge 1 \wedge 1 \wedge 1 \wedge D[47] \wedge D[45] \wedge 1 \wedge 1 \wedge 1 \wedge D[38] \wedge D[36] \wedge 1 \\
 &\wedge 1 \wedge 1 \wedge D[28] \wedge 1 \wedge 1 \wedge 1 \wedge 1 \wedge D[22] \wedge D[21] \wedge D[20] \wedge 1 \wedge 1 \wedge 1 \wedge 1 \wedge D[13] \wedge 1 \wedge D[5] \wedge D[4]; \\
 \text{CRC}[2] &= 1 \wedge 1 \wedge 1 \wedge 1 \wedge 1 \wedge 1 \wedge 1 \wedge D[62] \wedge D[61] \wedge 1 \wedge D[54] \wedge D[52] \wedge 1 \wedge 1 \wedge 1 \wedge 1 \wedge D[47] \wedge D[46] \wedge 1 \wedge 1 \wedge 1 \wedge D[38] \wedge D[37] \wedge 1 \wedge 1 \wedge 1 \wedge D[29] \\
 &\wedge D[28] \wedge 1 \wedge D[21] \wedge 1 \wedge 1 \wedge 1 \wedge D[14] \wedge D[12] \wedge 1 \wedge D[6] \wedge D[5] \wedge D[4]; \\
 \text{CRC}[3] &= 1 \wedge 1 \wedge D[68] \wedge 1 \wedge 1 \wedge 1 \wedge D[63] \wedge D[62] \wedge 1 \wedge D[55] \wedge D[53] \wedge D[52] \wedge 1 \wedge 1 \wedge 1 \wedge 1 \wedge D[47] \wedge D[44] \wedge 1 \wedge D[39] \wedge D[38] \wedge 1 \wedge 1 \wedge \\
 &\wedge D[30] \wedge D[29] \wedge 1 \wedge D[22] \wedge D[20] \wedge 1 \wedge 1 \wedge D[15] \wedge D[13] \wedge 1 \wedge D[7] \wedge D[6] \wedge D[5]; \\
 \text{CRC}[4] &= 1 \wedge 1 \wedge D[69] \wedge D[68] \wedge 1 \wedge 1 \wedge 1 \wedge D[63] \wedge D[60] \wedge 1 \wedge D[54] \wedge D[53] \wedge D[52] \wedge 1 \wedge 1 \wedge 1 \wedge 1 \wedge D[45] \wedge 1 \wedge 1 \wedge 1 \wedge D[39] \wedge 1 \wedge 1 \wedge D[31] \\
 &\wedge D[30] \wedge D[28] \wedge D[23] \wedge D[21] \wedge 1 \wedge 1 \wedge 1 \wedge D[14] \wedge D[12] \wedge 1 \wedge D[7] \wedge D[6]; \\
 \text{CRC}[5] &= 1 \wedge D[70] \wedge D[69] \wedge D[68] \wedge 1 \wedge 1 \wedge 1 \wedge D[61] \wedge 1 \wedge D[55] \wedge D[54] \wedge D[53] \wedge 1 \wedge 1 \wedge 1 \wedge 1 \wedge D[46] \wedge D[44] \wedge 1 \wedge 1 \wedge 1 \wedge D[36] \wedge 1 \wedge 1 \wedge \\
 &\wedge D[31] \wedge D[29] \wedge 1 \wedge D[22] \wedge D[20] \wedge 1 \wedge 1 \wedge D[15] \wedge D[13] \wedge 1 \wedge 1 \wedge D[7]; \\
 \text{CRC}[6] &= D[71] \wedge D[70] \wedge D[69] \wedge D[68] \wedge 1 \wedge 1 \wedge 1 \wedge D[62] \wedge 1 \wedge 1 \wedge D[55] \wedge D[54] \wedge D[52] \wedge 1 \wedge 1 \wedge D[47] \wedge D[45] \wedge 1 \wedge 1 \wedge 1 \wedge D[37] \wedge D[36] \\
 &\wedge 1 \wedge 1 \wedge D[30] \wedge 1 \wedge D[23] \wedge D[21] \wedge D[20] \wedge 1 \wedge 1 \wedge D[14] \wedge 1 \wedge 1 \wedge 1 \wedge 1; \\
 \text{CRC}[7] &= 1 \wedge D[71] \wedge D[70] \wedge D[69] \wedge 1 \wedge 1 \wedge 1 \wedge D[63] \wedge 1 \wedge 1 \wedge 1 \wedge D[55] \wedge D[53] \wedge D[52] \wedge 1 \wedge 1 \wedge 1 \wedge D[46] \wedge 1 \wedge 1 \wedge 1 \wedge D[38] \wedge D[37] \wedge 1 \wedge 1 \wedge 1 \wedge \\
 &D[31] \wedge 1 \wedge 1 \wedge D[22] \wedge D[21] \wedge 1 \wedge 1 \wedge D[15] \wedge 1 \wedge 1 \wedge 1;
 \end{aligned}$$

9.18.6 Simultaneous DM and CRC Functionality

When both DM and Write CRC are enabled in the DRAM mode register, the DRAM calculates CRC before sending the write data into the array. If there is a CRC error, the DRAM blocks the write operation and discards the data. For a x16, when the DRAM detects an error in CRC tree, DDR4 DRAMs should be able to mask all DQs.

9.18.7 Simultaneous MPR Write, Per DRAM Addressability and CRC Functionality

The following combination of DDR4 features are prohibited for simultaneous operation

- 1) MPR Write and Write CRC (Note: MPR Write is via Address pins)
- 2) Per DRAM Addressability and Write CRC (Note: Only MRS is allowed during PDA and also DQL0 is used for PDA detection)



9.19 Command Address Parity (CA Parity)

A[2:0] of MR5 are defined to enable or disable CA Parity in the DRAM. The default state of the CA Parity bits is disabled. If CA parity is enabled by programming a non-zero value to CA Parity Latency in the mode register (the Parity Error bit must be set to zero when enabling CA any Parity mode), then the DRAM has to ensure that there is no parity error before executing the command. The additional delay for executing the commands versus a parity disabled mode is programmed in the mode register (MR5 A[2:0]) when CA Parity is enabled (PL: Parity Latency) and is applied to commands that are latched via the rising edge of CK_t when CS_n is low. The command is held for the time of the Parity Latency before it is executed inside the device. This means that issuing timing of internal command is determined with PL. When CA Parity is enabled, only DES is allowed between valid commands to prevent DRAM from any malfunctioning. CA Parity Mode is supported when DLL-on Mode is enabled, use of CA Parity Mode when DLL-off Mode is enabled is not allowed.

CA Parity signal covers ACT_n, RAS_n/A16, CAS_n/A15, WE_n/A14 and the address bus including bank address and bank group bits. The control signals CKE, ODT and CS_n are not included. (e.g. for a 4 Gbit x16 monolithic device, parity is computed across BG0, BA1, BA0, A16/ RAS_n, A15/CAS_n, A14/WE_n, A13-A0 and ACT_n). (DRAM should internally treat any unused address pins as 0's, e.g. if a common die has stacked pins but the device is used in a monolithic application then the address pins used for stacking should internally be treated as 0's)

The convention of parity is even parity i.e. valid parity is defined as an even number of ones across the inputs used for parity computation combined with the parity signal. In other words the parity bit is chosen so that the total number of 1's in the transmitted signal, including the parity bit is even.

If a DRAM detects a CA parity error in any command as qualified by CS_n then it must perform the following steps:

- Ignore the erroneous command. Commands in max NnCK window (tPAR_UNKNOWN) prior to the erroneous command are not guaranteed to be executed. When a READ command in this NnCK window is not executed, the DRAM does not activate DQS outputs.
- Log the error by storing the erroneous command and address bits in the error log. (MPR page1)
- Set the Parity Error Status bit in the mode register to "1". The Parity Error Status bit must be set before the ALERT_n signal is released by the DRAM (i.e. tPAR_ALERT_ON + tPAR_ALERT_PW(min)).
- Assert the ALERT_n signal to the host (ALERT_n is active low) within tPAR_ALERT_ON time.
- Wait for all in-progress commands to complete. These commands were received tPAR_UNKNOWN before the erroneous command. If a parity error occurs on a command issued between the tXS_Fast and tXS window after self-refresh exit then the DRAM may delay the de-assertion of ALERT_n signal as a result of any internal on going refresh. (See Figure 47)
- Wait for tRAS_min before closing all the open pages. The DRAM is not executing any commands during the window defined by (tPAR_ALERT_ON + tPAR_ALERT_PW).
- After tPAR_ALERT_PW_min has been satisfied, the DRAM may de-assert ALERT_n.
- After the DRAM has returned to a known pre-charged state it may de-assert ALERT_n.
- After (tPAR_ALERT_ON + tPAR_ALERT_PW), the DRAM is ready to accept commands for normal operation. Parity latency will be in effect, however, parity checking will not resume until the memory controller has cleared the Parity Error Status bit by writing a "0"(the DRAM will execute any erroneous commands until the bit is cleared).
- It is possible that the DRAM might have ignored a refresh command during the (tPAR_ALERT_ON + tPAR_ALERT_PW) window or the refresh command is the first erroneous frame so it is recommended that the controller issues extra refresh cycles as needed.
- The Parity Error Status bit may be read any time after (tPAR_ALERT_ON + tPAR_ALERT_PW) to determine which DRAM had the error. The DRAM maintains the Error Log for the first erroneous command until the Parity Error Status bit is reset to "0".



Mode Register for CA Parity Error is defined as follows. CA Parity Latency bits are write only, Parity Error Status bit is read/write and error logs are read only bits. The controller can only program the Parity Error Status bit to “0”. If the controller illegally attempts to write a “1” to the Parity Error Status bit the DRAM does not guarantee that parity will be checked. The DRAM may opt to block the controller from writing a “1” to the Parity Error Status bit.

Table 39 – Mode Registers for CA Parity

CA Parity Latency MR5[2:0]*	Speed bins	CA Parity Error Status MR5[4]	Errant C/A Frame
000 = Disabled	-	0=clear	ACT_n, BG0, BA0, BA1, PAR, A16/RAS_n, A15/CAS_n, A14/WE_n, A13:A0
001 = 4 Clocks	1600,1866,2133		
010 = 5 Clocks	2400, 2666	1=Error	
011 = 6 Clocks	3200		
Reserved	RFU		

Notes:

1. Parity Latency is applied to all commands.
2. Parity Latency can be changed only from a C/A Parity disabled state, i.e. a direct change from PL= 4 → PL= 5 is not allowed. Correct sequence is PL= 4 → Disabled → PL= 5.
3. Parity Latency is applied to write and read latency. Write Latency = AL+CWL+PL. Read Latency = AL+CL+PL.

DDR4 SDRAM supports MR bit for “Persistent Parity Error Mode”. This mode is enabled by setting MR5 A9=High and when it is enabled, DRAM resumes checking CA Parity after the alert_n is deasserted, even if Parity Error Status bit is set as High. If multiple errors occur before the Error Status bit is cleared the Error log in MPR page 1 should be treated as ‘Don’t Care’. In “Persistent Parity Error Mode” the Alert_n pulse will be asserted and deasserted by the DRAM as defined with the min. and max. value for tPAR_ALERT_PW. The controller must issue DESELECT commands once it detects the Alert_n signal, this response time is defined as tPAR_ALERT_RSP.

The following figure captures the flow of events on the CA bus and the ALERT_n signal.

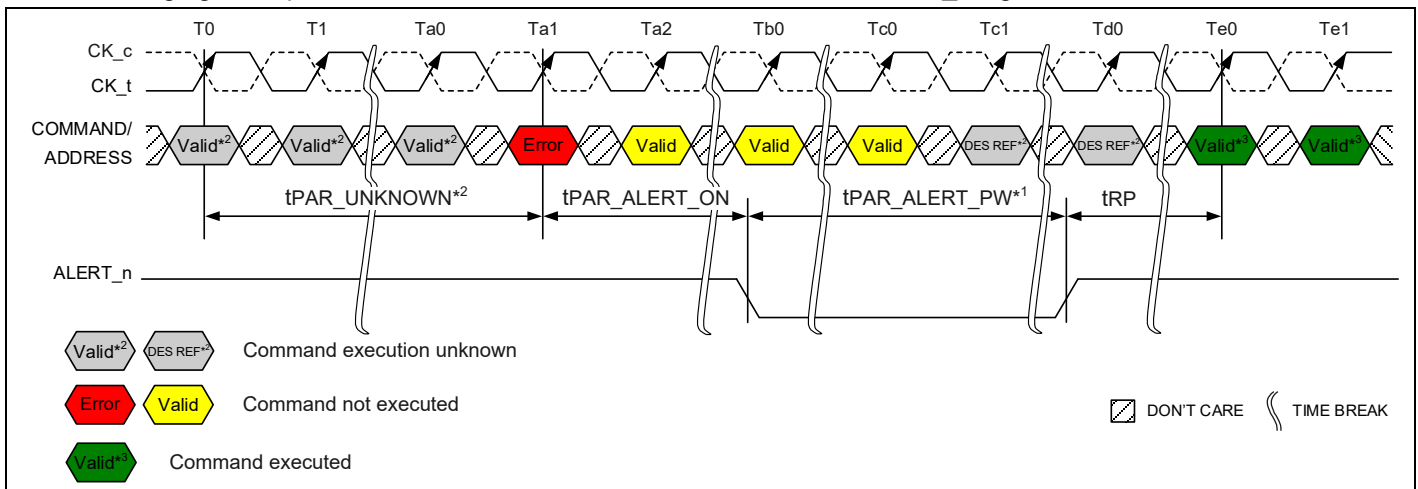

Notes:

1. DRAM is emptying queues; Precharge All and parity checking off until Parity Error Status bit cleared.
2. Command execution is unknown the corresponding DRAM internal state change may or may not occur. The DRAM Controller should consider both cases and make sure that the command sequence meets the specifications.
3. Normal operation with parity latency (CA Parity Persistent Error Mode disabled). Parity checking off until Parity Error Status bit cleared.

Figure 43 – Normal CA Parity Error Checking Operation

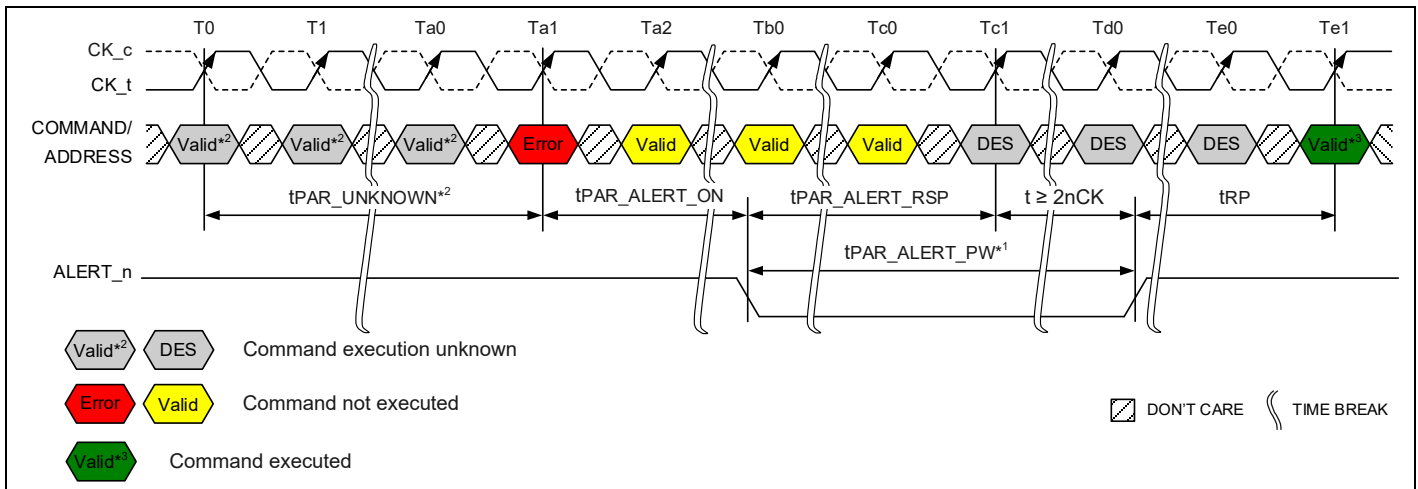

Notes:

1. DRAM is emptying queues; Precharge All and parity check re-enable finished by tPAR_ALERT_PW.
2. Command execution is unknown the corresponding DRAM internal state change may or may not occur. The DRAM Controller should consider both cases and make sure that the command sequence meets the specifications.
3. Normal operation with parity latency and parity checking (CA Parity Persistent Error Mode enabled).

Figure 44 – Persistent CA Parity Error Checking Operation

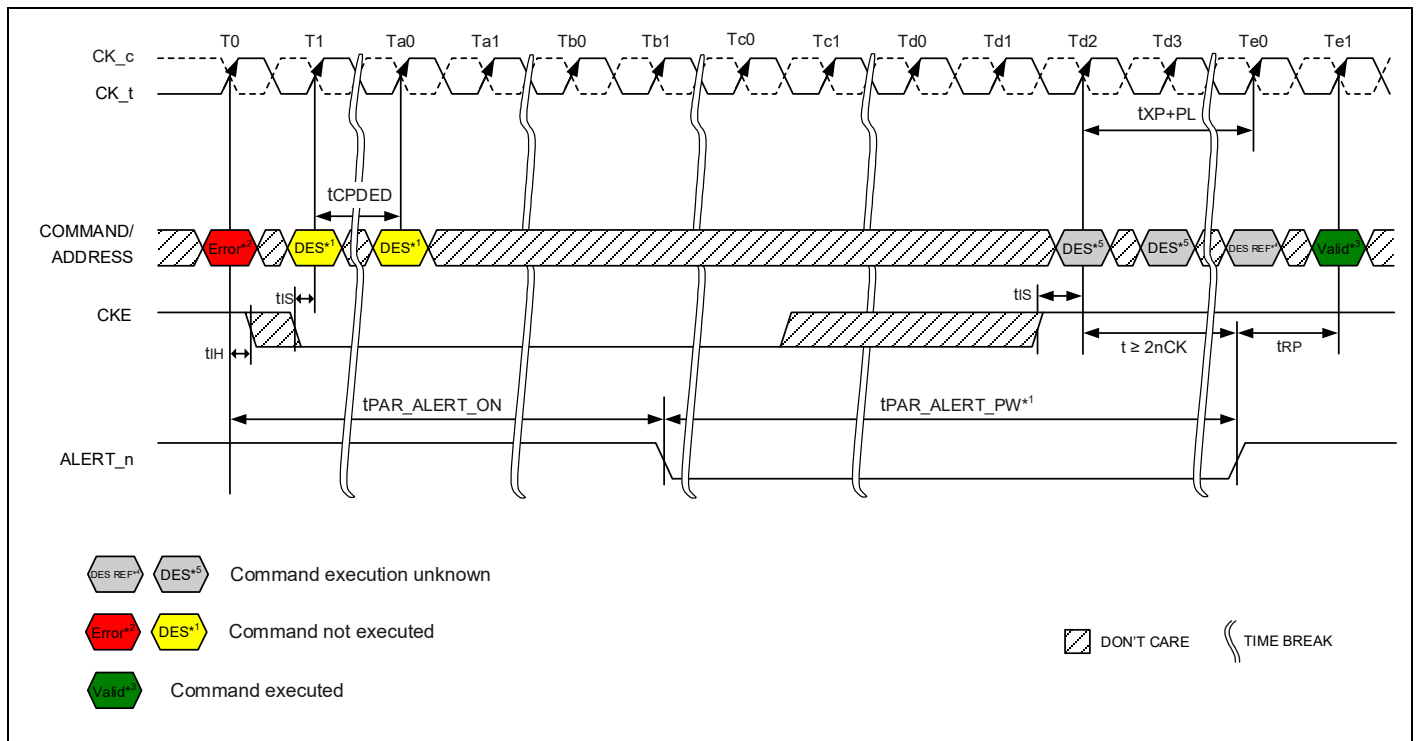

Notes:

1. Deselect command only allowed.
2. Error could be Precharge or Activate.
3. Normal operation with parity latency (CA Parity Persistent Error Mode disable). Parity checking is off until Parity Error Status bit cleared.
4. Command execution is unknown the corresponding DRAM internal state change may or may not occur. The DRAM Controller should consider both cases and make sure that the command sequence meets the specifications.
5. Deselect command only allowed CKE may go high prior to Td2 as long as DES commands are issued.

Figure 45 – CA Parity Error Checking - PDE/PDX

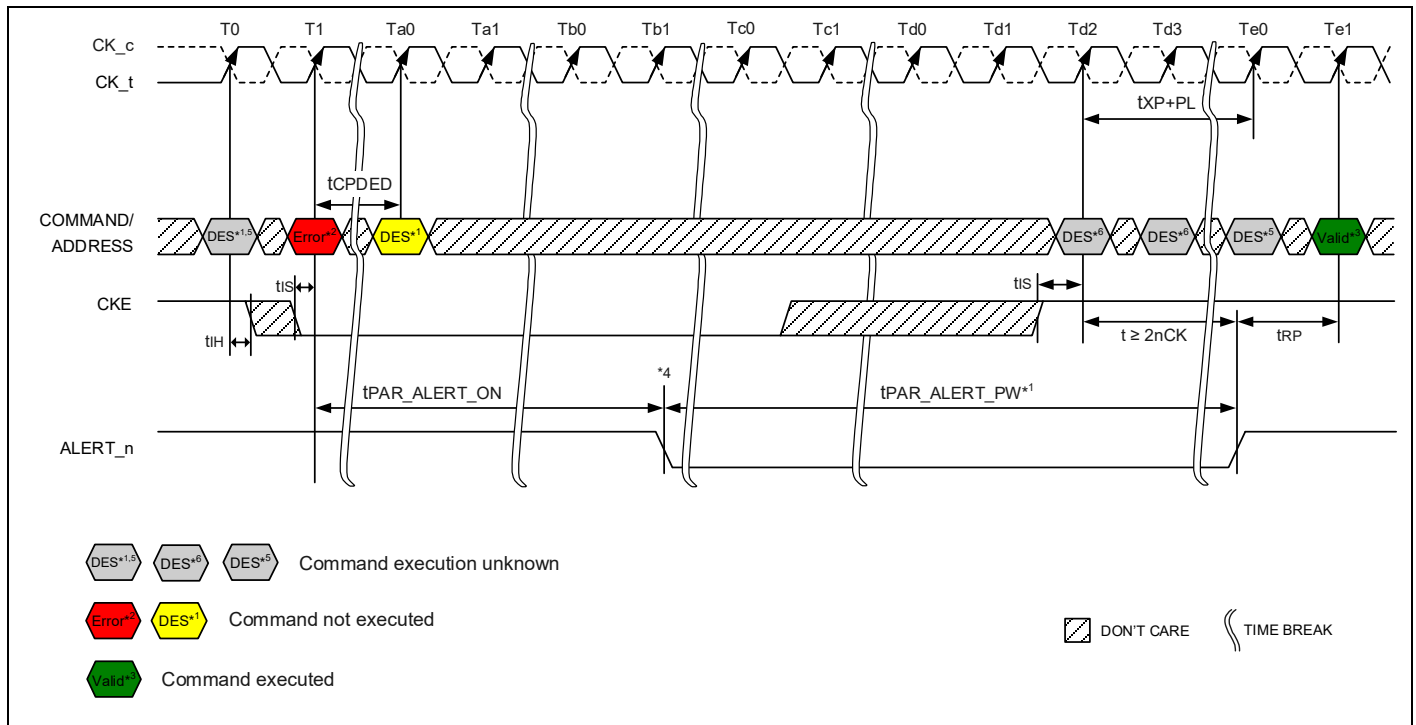

Notes:

1. Deselect command only allowed.
2. Self Refresh command error. DRAM masks the intended SRE command enters Precharge Power Down.
3. Normal operation with parity latency (CA Parity Persistent Error Mode disable). Parity checking is off until Parity Error Status bit cleared.
4. Controller cannot disable clock until it has been able to have detected a possible CA Parity error.
5. Command execution is unknown the corresponding DRAM internal state change may or may not occur. The DRAM Controller should consider both cases and make sure that the command sequence meets the specifications.
6. Deselect command only allowed CKE may go high prior to Tc2 as long as DES commands are issued.

Figure 46 – CA Parity Error Checking - SRE Attempt

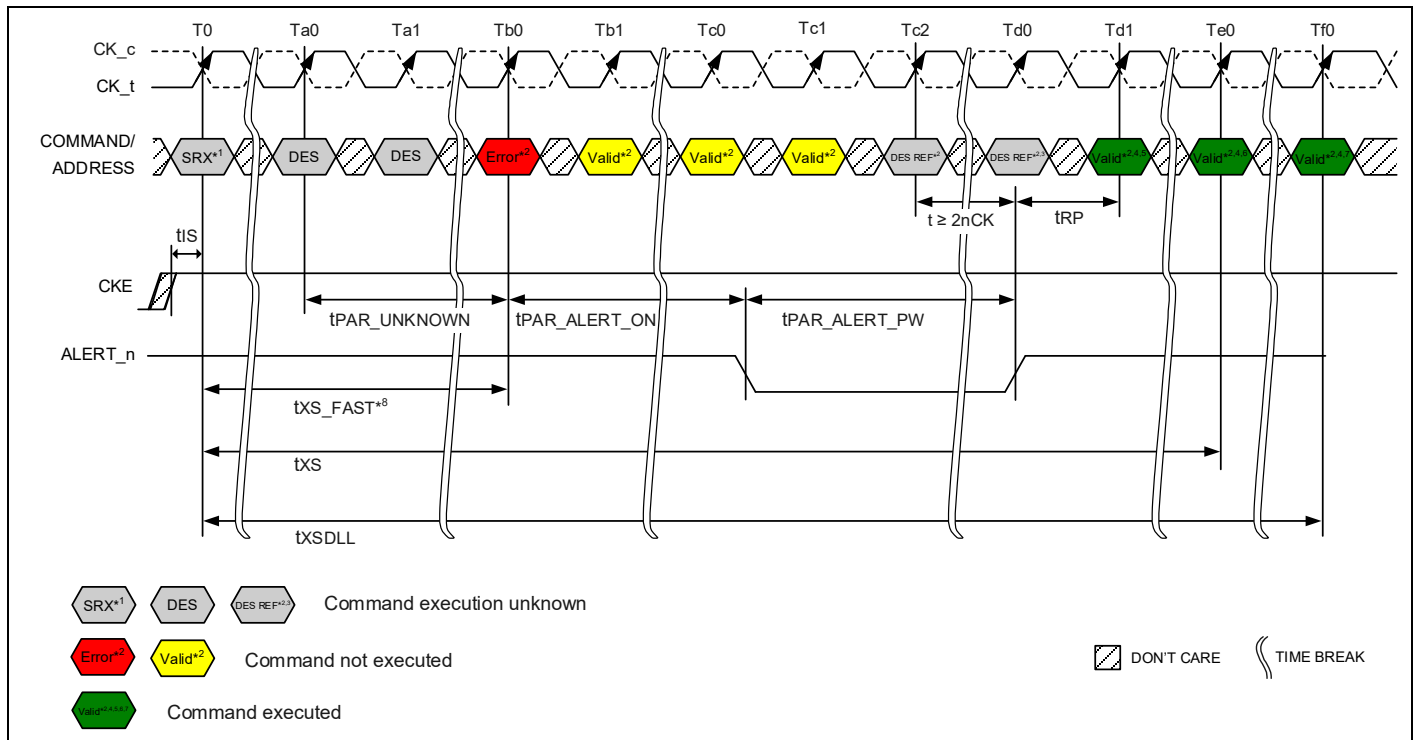

Notes:

1. Self Refresh Abort = Disable: MR4 [A9=0].
2. Input commands are bounded by tXSDLL, tXS, tXS_ABORT and tXS_FAST timing.
3. Command execution is unknown the corresponding DRAM internal state change may or may not occur. The DRAM Controller should consider both cases and make sure that the command sequence meets the specifications.
4. Normal operation with parity latency (CA Parity Persistent Error Mode disabled). Parity checking off until Parity Error Status bit cleared.
5. Only MRS (limited to those described in the Self-Refresh Operation section), ZQCS or ZQCL command allowed.
6. Valid commands not requiring a locked DLL.
7. Valid commands requiring a locked DLL.
8. This figure shows the case from which the error occurred after tXS_FAST. An error also occur after tXS_ABORT and tXS.

Figure 47 – CA Parity Error Checking - SRX



Command/Address parity entry and exit timings

When in CA Parity mode, including entering and exiting CA Parity mode, users must wait tMRD_PAR before issuing another MRS command, and wait tMOD_PAR before any other commands.

tMOD_PAR = tMOD + PL

tMRD_PAR = tMOD + PL

For CA parity entry, PL in the equations above is the parity latency programmed with the MRS command entering CA parity mode.

For CA parity exit, PL in the equations above is the programmed parity latency prior to the MRS command exiting CA parity mode.

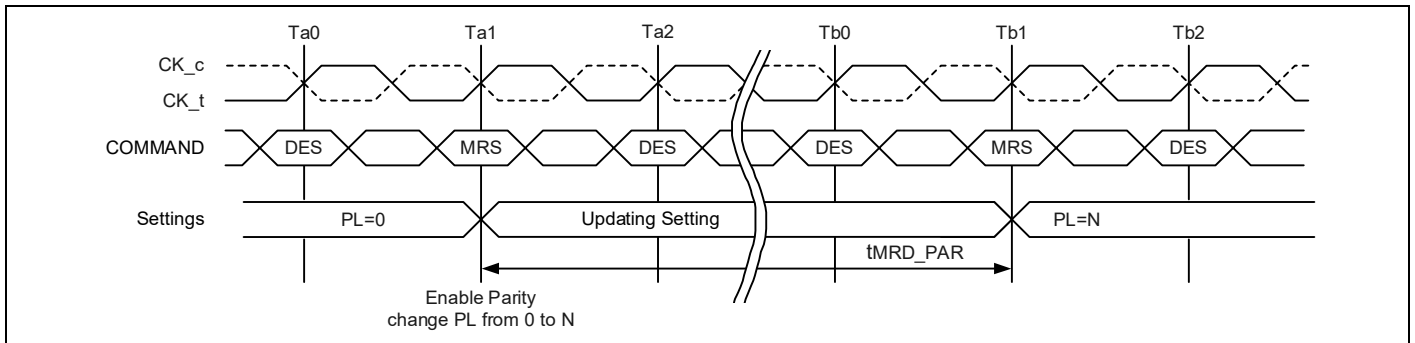

Notes:

1. tMRD_PAR = tMOD + N; where N is the programmed parity latency with the MRS command entering CA parity mode.
2. Parity check is not available at Ta1 of MRS command due to PL=0 being valid.
3. In case parity error happens at Tb1 of MRS command, tPAR_ALERT_ON is "N[nCK] + 6[nS]".

Figure 48 – Parity entry timing example - tMRD_PAR

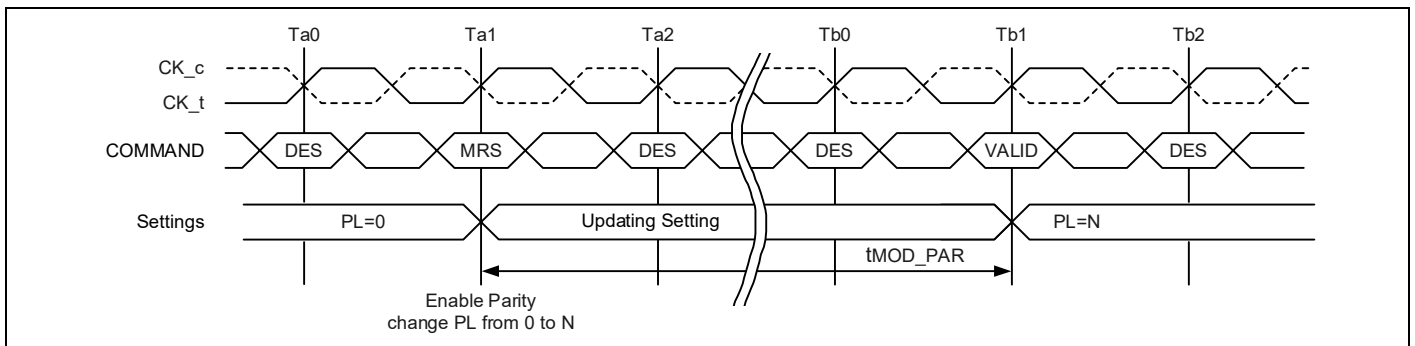

Notes:

1. tMOD_PAR = tMOD + N; where N is the programmed parity latency with the MRS command entering CA parity mode.
2. Parity check is not available at Ta1 of MRS command due to PL=0 being valid.
3. In case parity error happens at Tb1 of VALID command, tPAR_ALERT_ON is "N[nCK] + 6[nS]".

Figure 49 – Parity entry timing example - tMOD_PAR

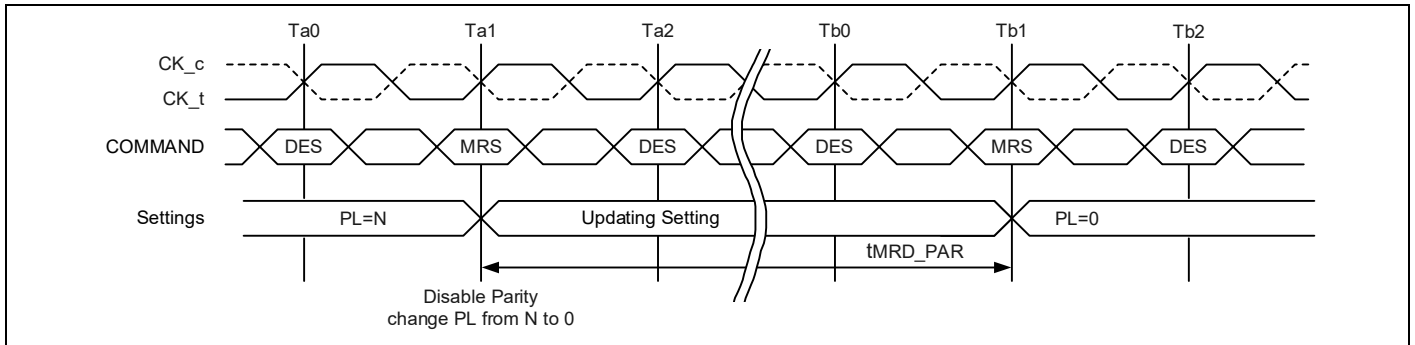

Notes:

1. $tMRD_PAR = tMOD + N$; where N is the programmed parity latency prior to the MRS command exiting CA parity mode.
2. In case parity error happens at Ta1 of MRS command, $tPAR_ALERT_ON$ is “N[nCK] + 6[nS]”.
3. Parity check is not available at Tb1 of MRS command due to disabling parity mode.

Figure 50 – Parity exit timing example - tMRD_PAR

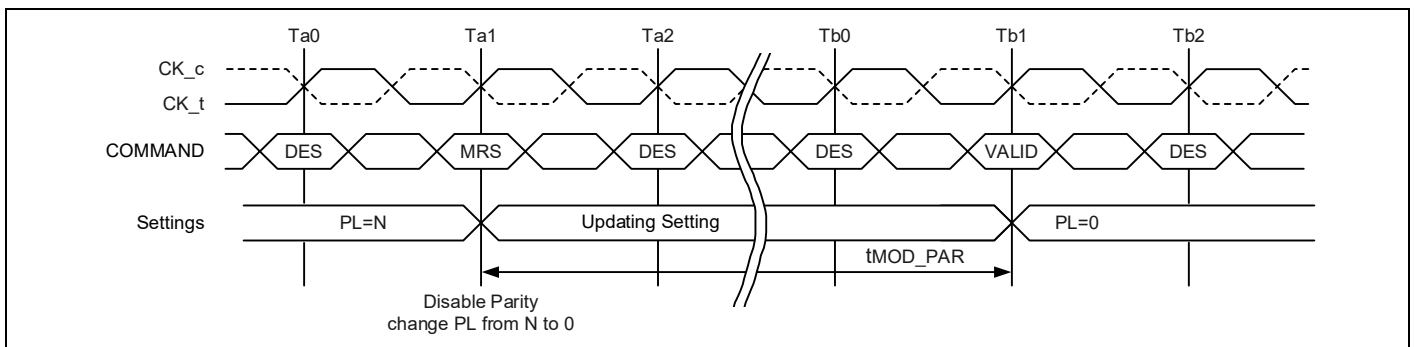

Notes:

1. $tMOD_PAR = tMOD + N$; where N is the programmed parity latency prior to the MRS command exiting CA parity mode.
2. In case parity error happens at Ta1 of MRS command, $tPAR_ALERT_ON$ is “N[nCK] + 6[nS]”.
3. Parity check is not available at Tb1 of VALID command due to disabling parity mode.

Figure 51 – Parity exit timing example - tMOD_PAR

9.19.1 CA Parity Error Log Readout

MPR Mapping of CA Parity Error Log*1 (Page1)

Address	MPR Location	[7]	[6]	[5]	[4]	[3]	[2]	[1]	[0]
BA1:BA0 = 0:1	00 = MPR0	A7	A6	A5	A4	A3	A2	A1	A0
	01 = MPR1	CAS_n/A15	WE_n/A14	A13	A12	A11	A10	A9	A8
	10 = MPR2	PAR	ACT_n	BG1	BG0	BA1	BA0	A17	RAS_n/ A16
	11 = MPR3	CRC Error Status	CA Parity Error Status	CA Parity Latency			C2	C1	C0

Notes:

1. MPR used for CA parity error log readout is enabled by setting A[2] in MR3.
2. For x16 device BG1 is not used, MPR2[5] should be treated as don't care. The 4Gb DRAM A17 is not used, MPR2[1] should be treated as don't care.
3. If a device is used in monolithic application, where C[2:0] are not used, and then MPR3[2:0] should be treated as don't care.



9.20 Control Gear-down Mode

The following description represents the sequence for the gear-down mode which is specified with MR3:A3. This mode is allowed just during initialization and self refresh exit. The DRAM defaults in 1/2 rate (1N) clock mode and utilizes a low frequency MRS command followed by a sync pulse to align the proper clock edge for operating the control lines CS_n, CKE and ODT in 1/4rate (2N) mode. For operation in 1/2 rate mode MRS command for gear-down or sync pulse are not required. DRAM defaults in 1/2 rate mode.

General sequence for operation in gear-down during initialization

- DRAM defaults to a 1/2 rate (1N mode) internal clock at power up/reset
- Assertion of Reset
- Assertion of CKE enables the DRAM
- MRS is accessed with a low frequency N*tCK MRS gear-down CMD (set MR3 A[3] to 1)
NtCK static MRS command qualified by 1N CS_n
- DRAM controller sends 1N sync pulse with a low frequency N*tCK NOP CMD
tSYNC_GEAR is an even number of clocks
Sync pulse on even clock boundary from MRS CMD
- Initialization sequence, including the expiration of tDLLK and tZQinit, starts in 2N mode after tCMD_GEAR from 1N Sync Pulse.

General sequence for operation in gear-down after self refresh exit

- DRAM reset to 1N mode during self refresh
- MRS is accessed with a low frequency N*tCK MRS gear-down CMD (set MR3 A[3] to 1)
NtCK static MRS command qualified by 1N CS_n which meets tXS or tXS_Abort
Only Refresh command is allowed to be issued to DRAM before NtCK static MRS command
- DRAM controller sends 1N sync pulse with a low frequency N*tCK NOP CMD
tSYNC_GEAR is an even number of clocks
Sync pulse is on even clock boundary from MRS CMD
- Valid command not requiring locked DLL is available in 2N mode after tCMD_GEAR from 1N Sync Pulse
- Valid command requiring locked DLL is available in 2N mode after tDLLK from 1N Sync Pulse

If operation is 1/2 rate (1N) mode after self refresh, no N*tCK MRS command or sync pulse is required during self refresh exit. The min exit delay is tXS, or tXS_Abort to the first valid command.

The DRAM may be changed from 1/4 rate (2N) to 1/2 rate (1N) by entering Self Refresh Mode, which will reset to 1N automatically. Changing from 1/4 (2N) to 1/2 rate (1N) by any other means, including setting MR3 A[3] from 1 to 0, can result in loss of data and operation of the DRAM uncertain.

For the operation of gear-down mode in 1/4 rate, the following MR settings should be applied

CAS Latency (MR0 A[6:4,2]): Even number of clocks

Write Recovery and Read to Precharge (MR0 A[11:9]): Even number of clocks

Additive Latency (MR1 A[4:3]): 0, CL - 2

CAS Write Latency (MR2 A[5:3]): Even number of clocks

CS to Command/Address Latency Mode (MR4 A[8:6]): Even number of clocks

CA Parity Latency Mode (MR5 A[2:0]): Even number of clocks

CAL or CA parity mode must be disabled prior to Gear-down MRS command. They can be enabled again after tSYNC_GEAR and tCMD_GEAR periods are satisfied.

The diagram below illustrates the sequence for control operation in 2N mode during initialization.

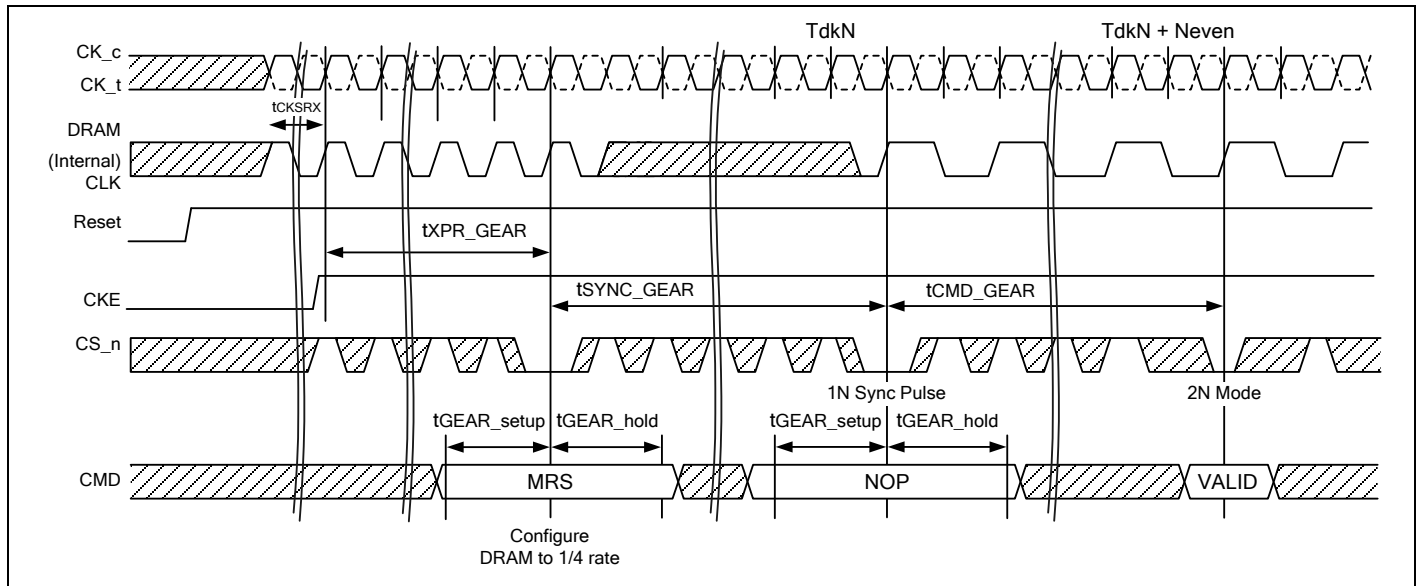

Note: Only DES is allowed during tSYNC_GEAR.

Figure 52 – Gear-down (2N) mode entry sequence during initialization

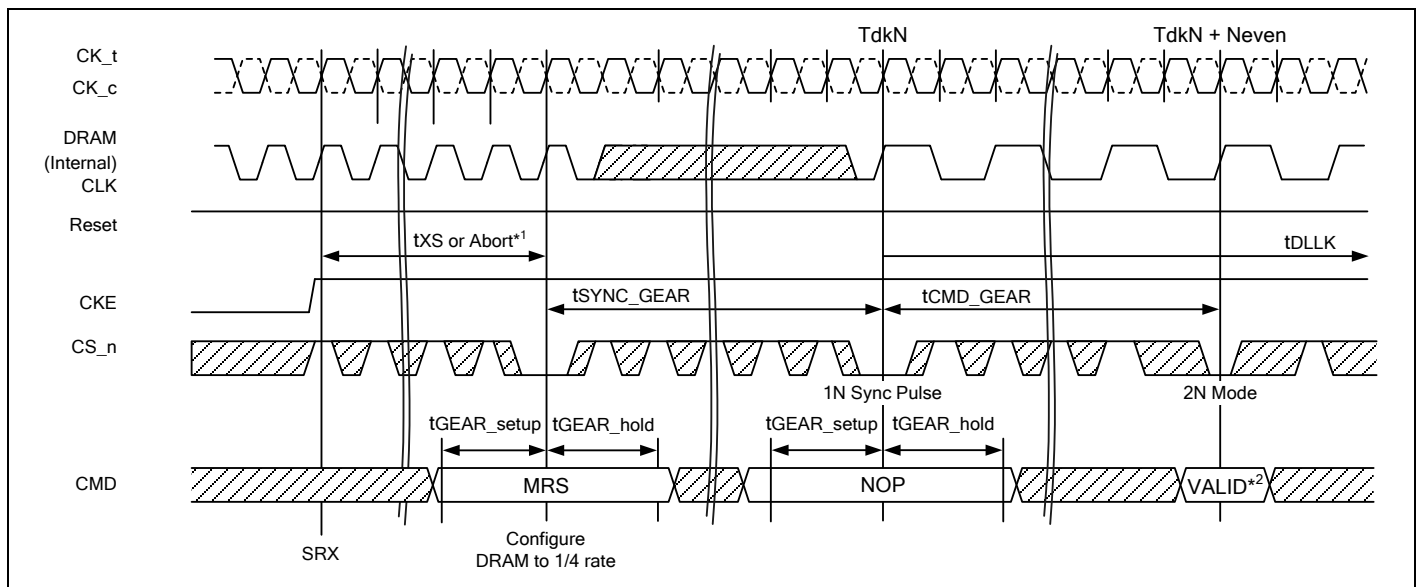

Notes:

1. CKE High Assert to Gear-down Enable Time (tXS, tXS_Abort) depend on MR setting. A correspondence of tXS/tXS_Abort and MR Setting is as follows
 - MR4 A[9] = 0: tXS
 - MR4 A[9] = 1: tXS_Abort
2. Command not requiring locked DLL.
3. Only DES is allowed during tSYNC_GEAR.

Figure 53 – Gear-down (2N) mode entry sequence after self refresh exit (SRX)

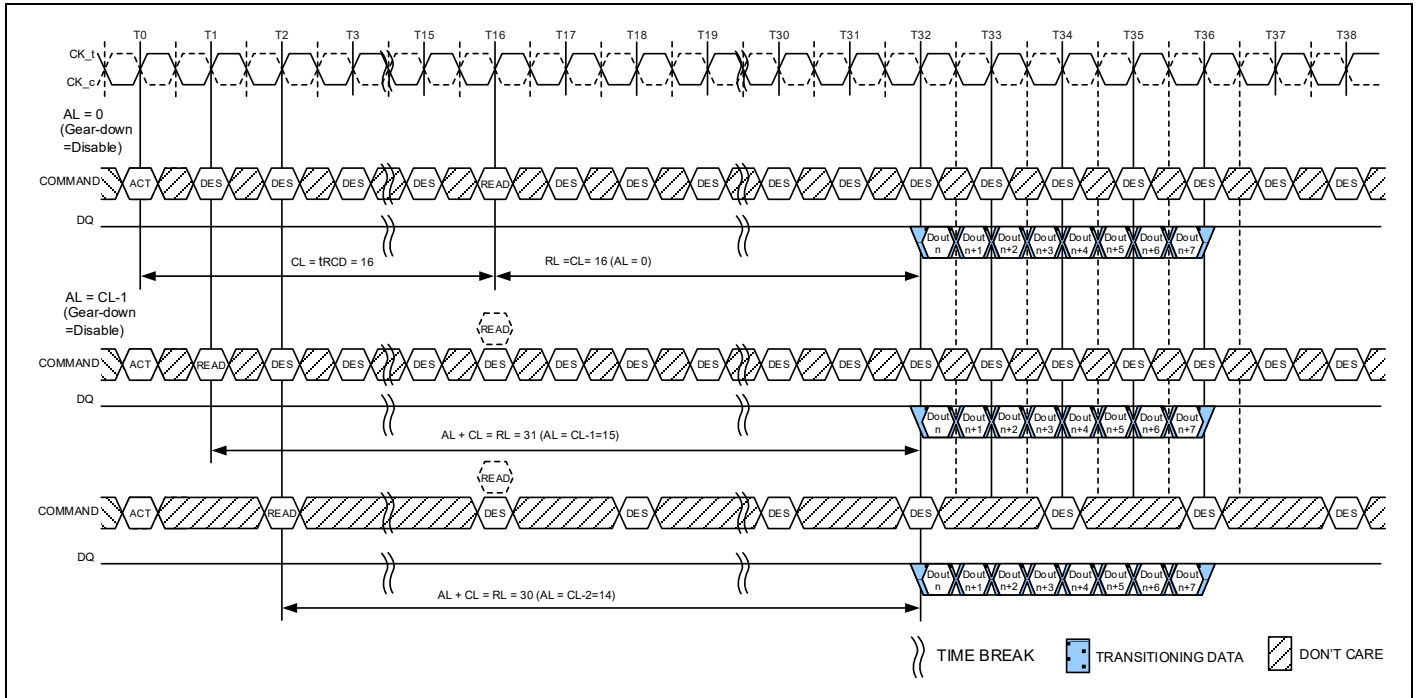

Notes:

1. BL=8, trCD=CL=16.
2. Dout n = data-out from column n.
3. DES commands are shown for ease of illustration; other commands may be valid at these times.
4. CA Parity = Disable, CS to CA Latency = Disable, Read DBI = Disable.

Figure 54 – Comparison Timing Diagram between Gear-down Disable and Enable

9.21 DDR4 Key Core Timing

DDR4, Core Timing

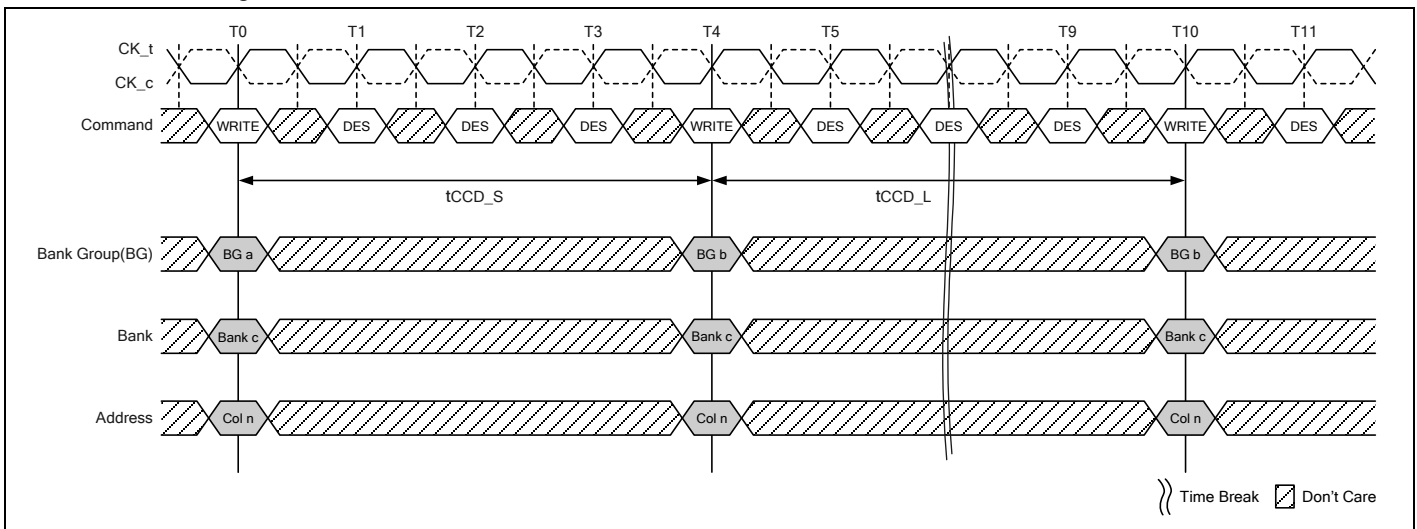

Notes:

1. tCCD_S: CAS_n-to-CAS_n delay (short): Applies to consecutive CAS_n to different Bank Group (i.e. T0 to T4)
2. tCCD_L: CAS_n-to-CAS_n delay (long): Applies to consecutive CAS_n to the same Bank Group (i.e. T4 to T10)

Figure 55 – tCCD Timing (WRITE to WRITE Example)

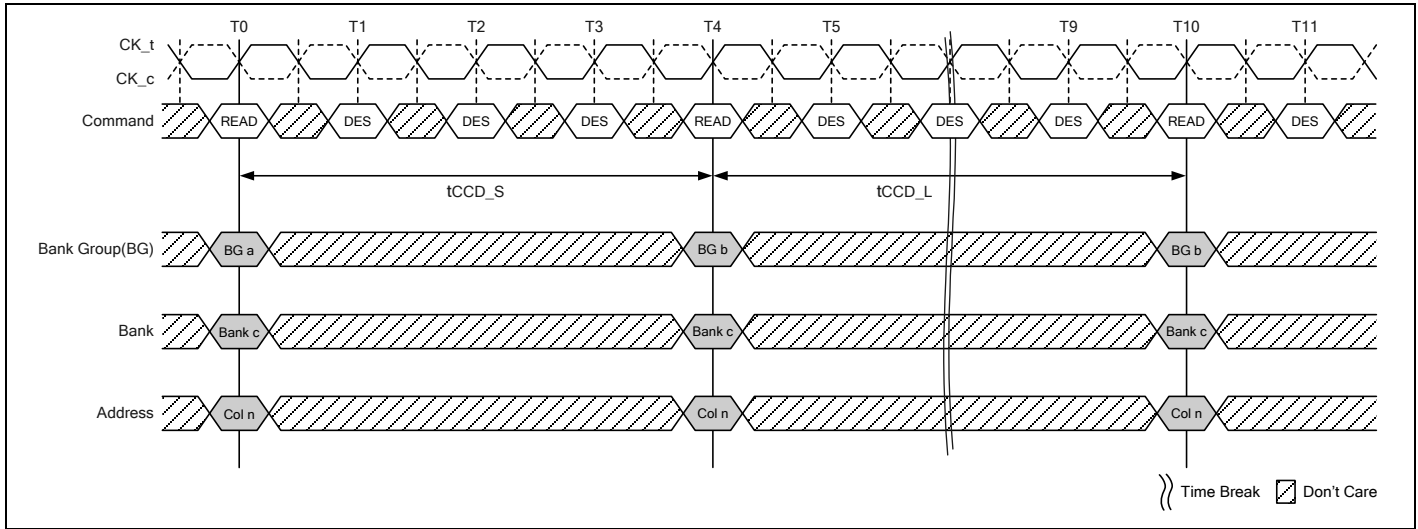

Notes:

1. tCCD_S: CAS_n-to-CAS_n delay (short): Applies to consecutive CAS_n to different Bank Group (i.e. T0 to T4)
2. tCCD_L: CAS_n-to-CAS_n delay (long): Applies to consecutive CAS_n to the same Bank Group (i.e. T4 to T10)

Figure 56 – tCCD Timing (READ to READ Example)

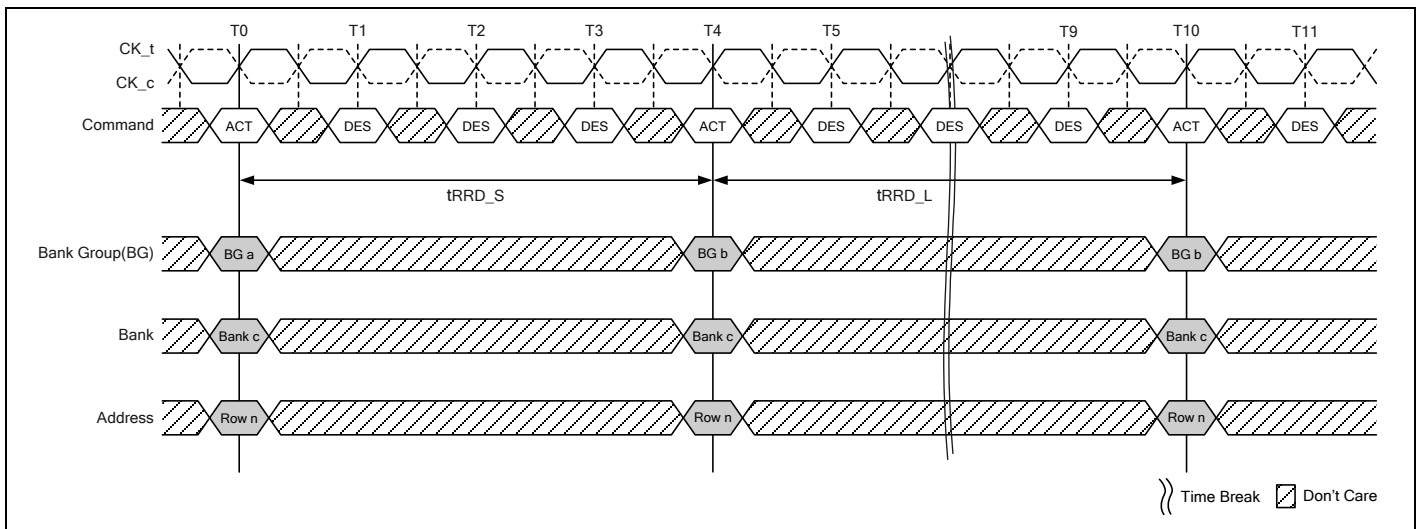

Notes:

1. tRRD_S: ACTIVATE to ACTIVATE Command period (short): Applies to consecutive ACTIVATE Commands to different Bank Group (i.e. T0 to T4)
2. tRRD_L: ACTIVATE to ACTIVATE Command period (long): Applies to consecutive ACTIVATE Commands to the different Banks of the same Bank Group (i.e. T4 to T10)

Figure 57 – tRRD Timing

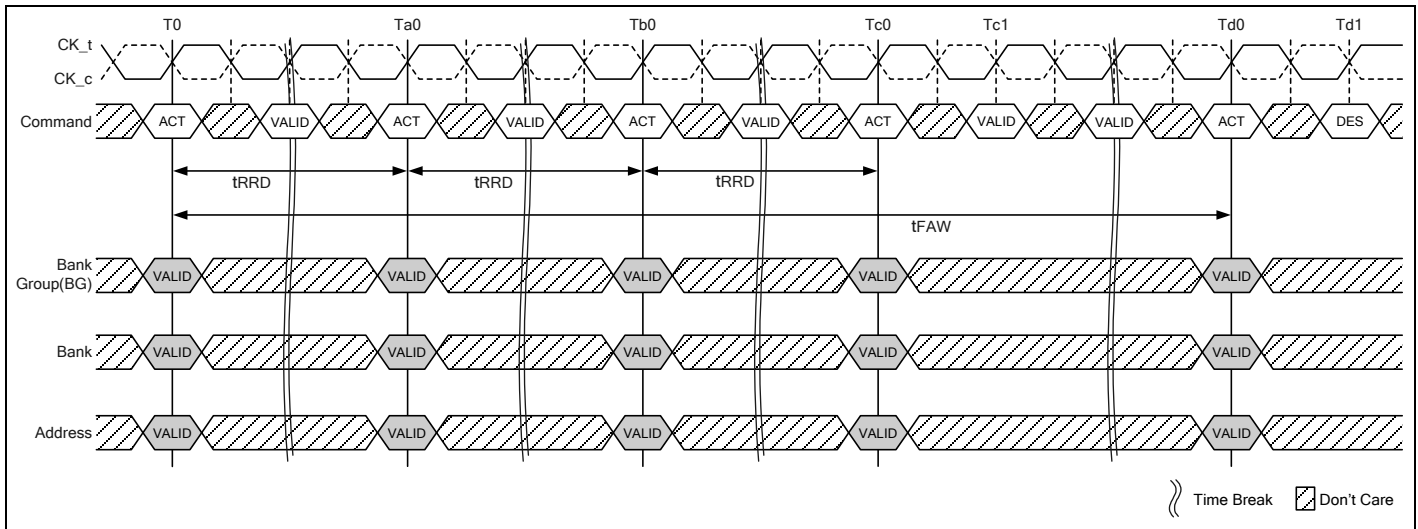

Note: tFAW: Four activate window.

Figure 58 – tFAW Timing

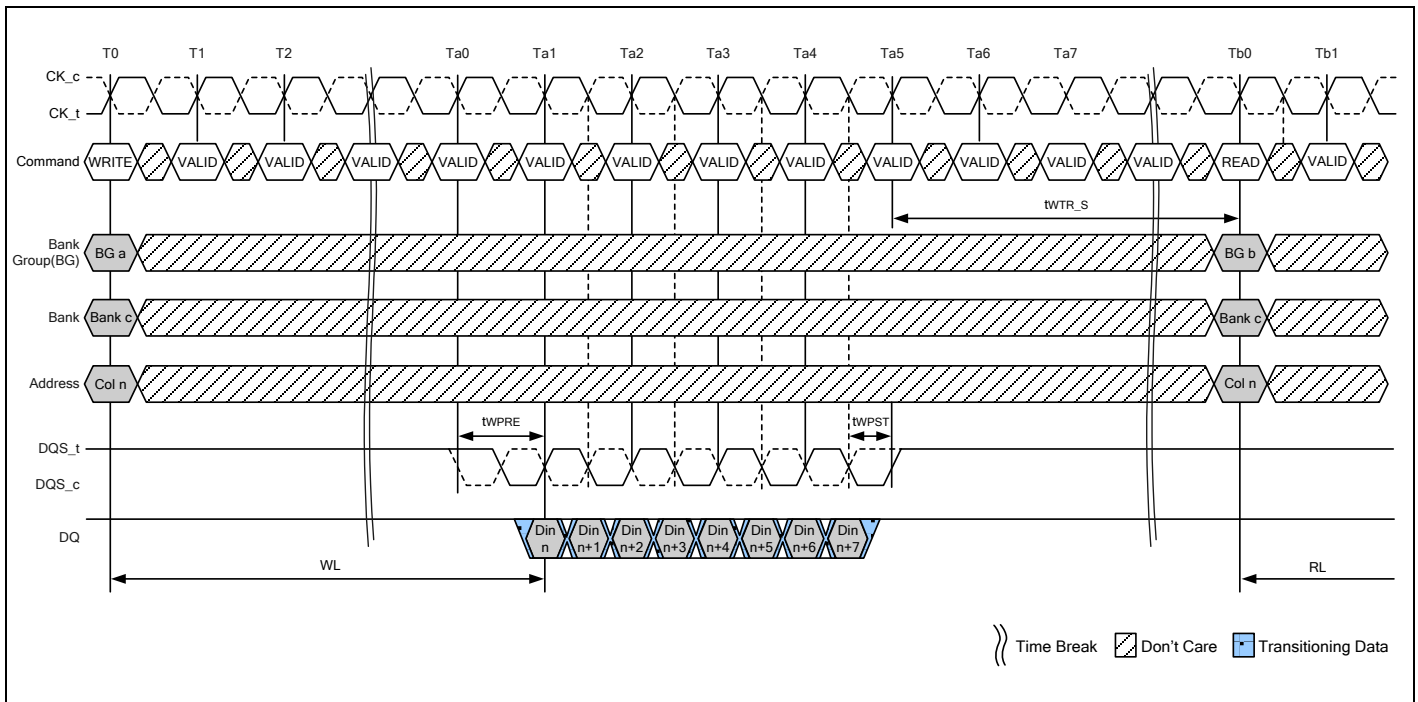

Note: tWTR_S: Delay from start of internal write transaction to internal read command to a different Bank Group. When AL is non-zero, the external read command at Tb0 can be pulled in by AL.

Figure 59 – tWTR_S Timing (WRITE to READ, Different Bank Group, CRC and DM Disabled)

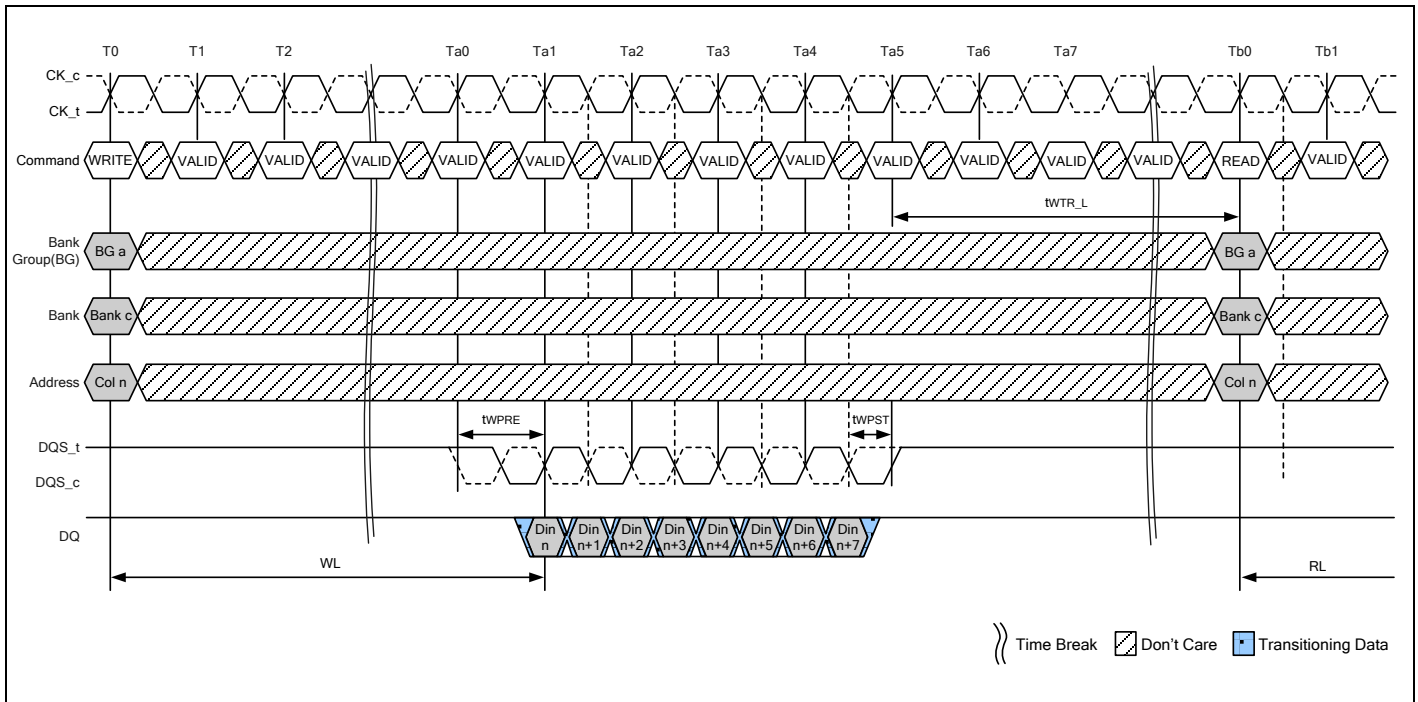

Note: t_{WTR_L} : Delay from start of internal write transaction to internal read command to the same Bank Group. When AL is nonzero, the external read command at $Tb0$ can be pulled in by AL.

Figure 60 – t_{WTR_L} Timing (WRITE to READ, Same Bank Group, CRC and DM Disabled)

9.22 Programmable Preamble

The DQS preamble can be programmed to one or the other of 1tCK and 2tCK preamble; selectable via MRS (MR4 A[12:11]).

The 1tCK preamble applies to all speed grade and the 2tCK preamble is valid for DDR4-2400/2666/3200 Speed bin Tables.

9.22.1 Write Preamble

DDR4 supports a programmable write preamble. The 1tCK or 2tCK Write Preamble is selected via MR4 A[12]. Write preamble modes of 1tCK and 2tCK are shown below.

When operating in 2tCK Write preamble mode; in MR2 Table 6, CWL of 1st Set needs to be incremented by 2nCK and CWL of 2nd Set does not need increment of it. t_{WTR} must be increased by one clock cycle from the t_{WTR} required in the applicable speed bin table. WR must be programmed to a value one or two clock cycle(s), depending on available settings, greater than the WR setting required per the applicable speed bin table.

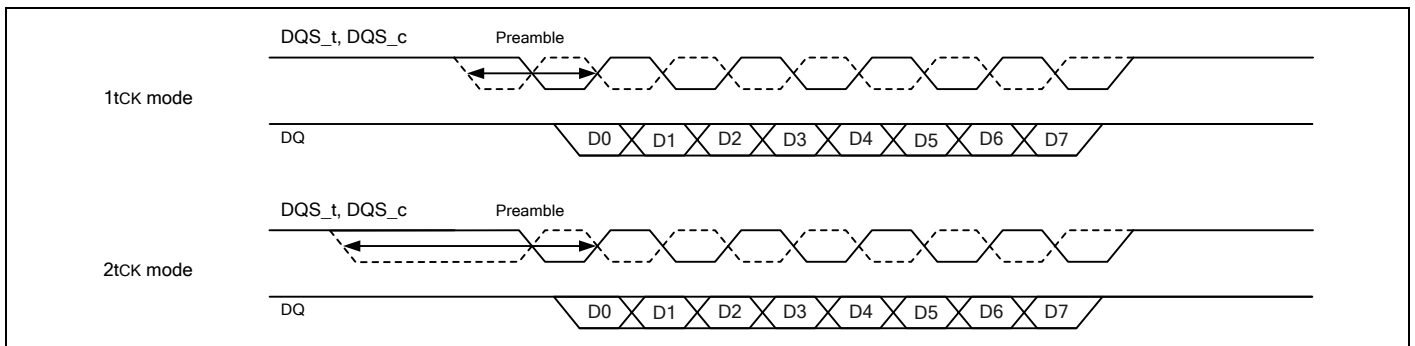



The timing diagrams contained in Figure 61, Figure 62 and Figure 63 illustrate 1 and 2tCK preamble scenarios for consecutive write commands with tCCD timing of 4, 5 and 6nCK, respectively. Setting tCCD to 5nCK is not allowed in 2tCK preamble mode.

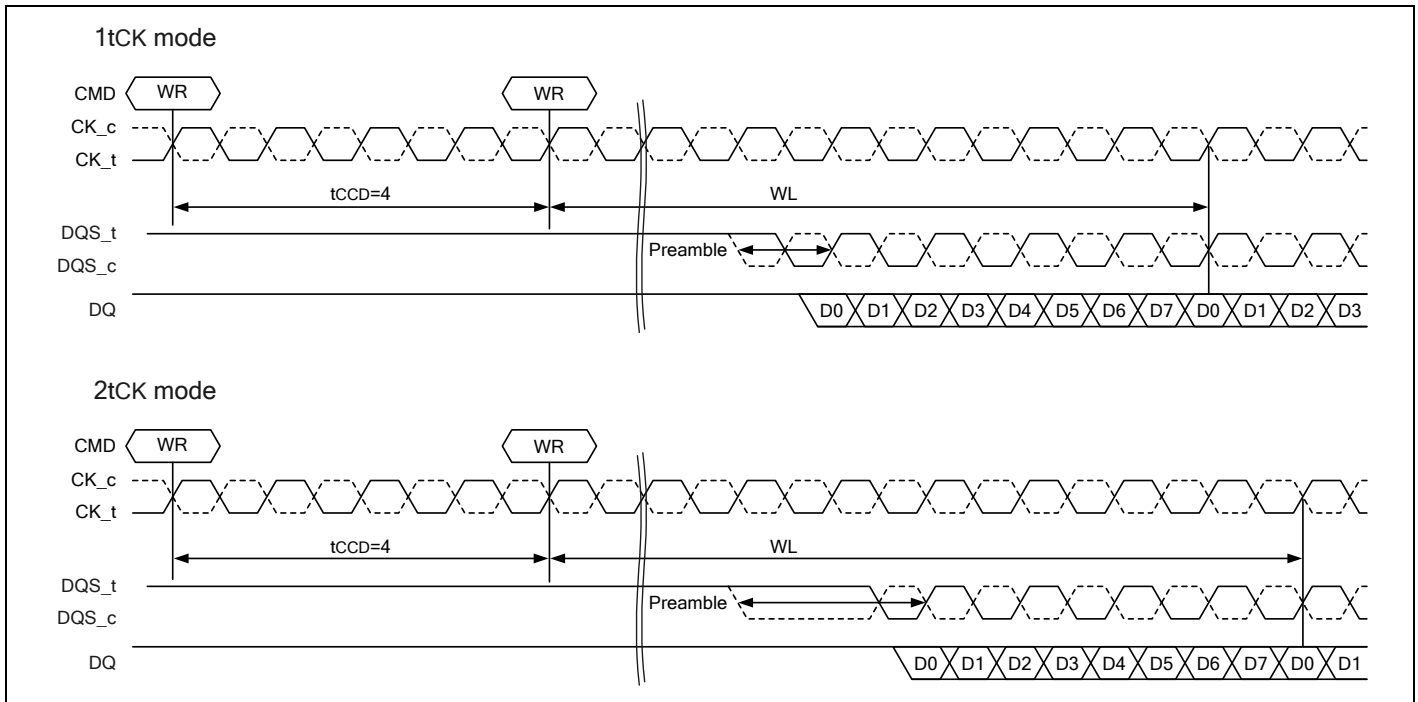

Figure 61 – 1tCK vs. 2tCK WRITE Preamble Mode, tCCD=4 (AL=PL=0)

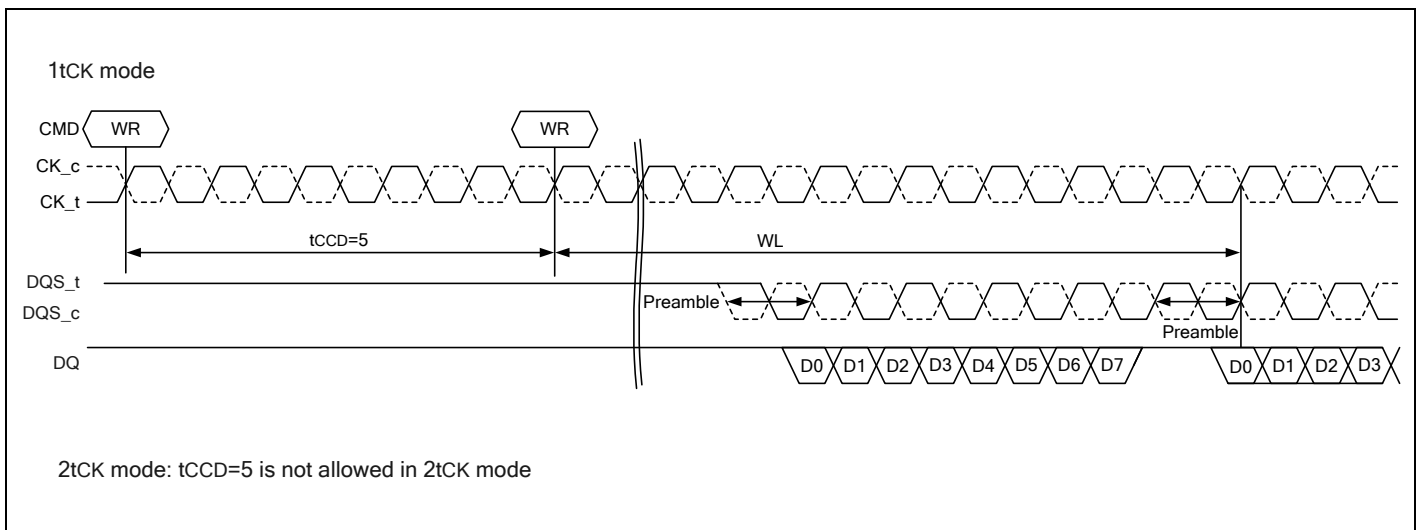

Figure 62 – 1tCK vs. 2tCK WRITE Preamble Mode, tCCD=5 (AL=PL=0)

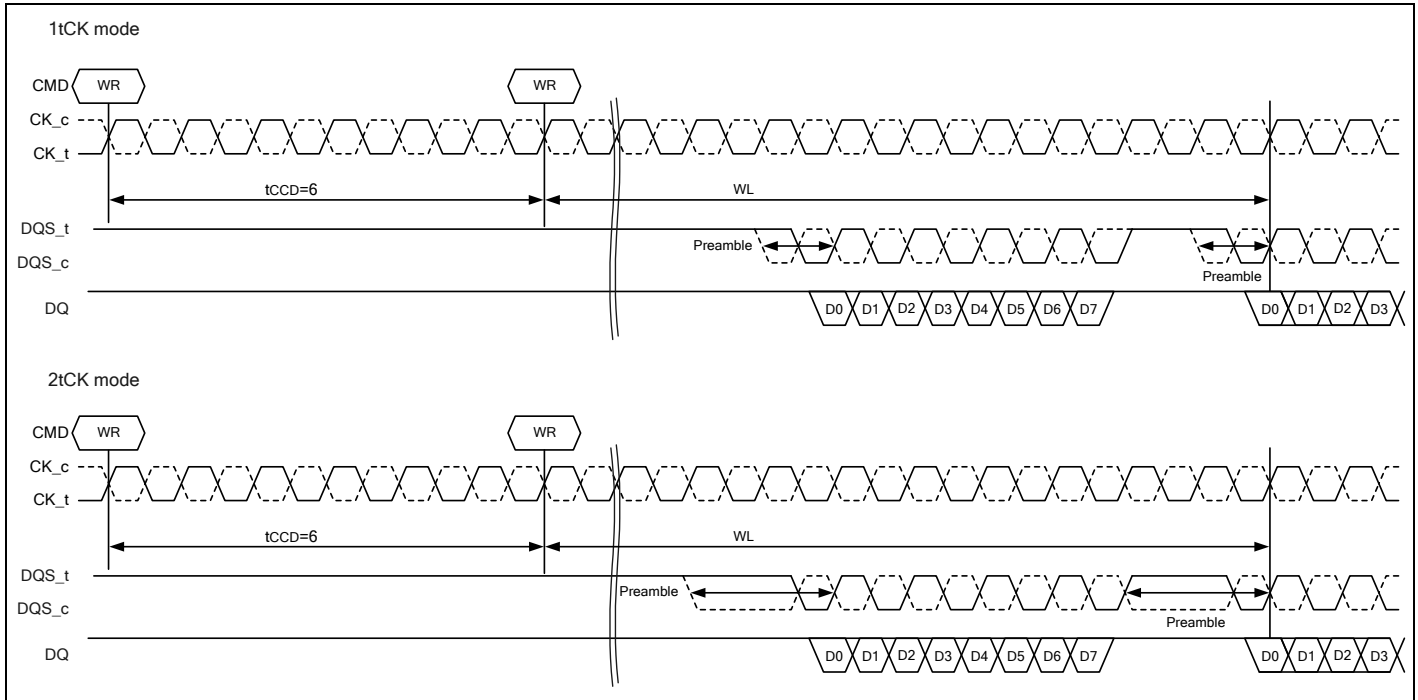
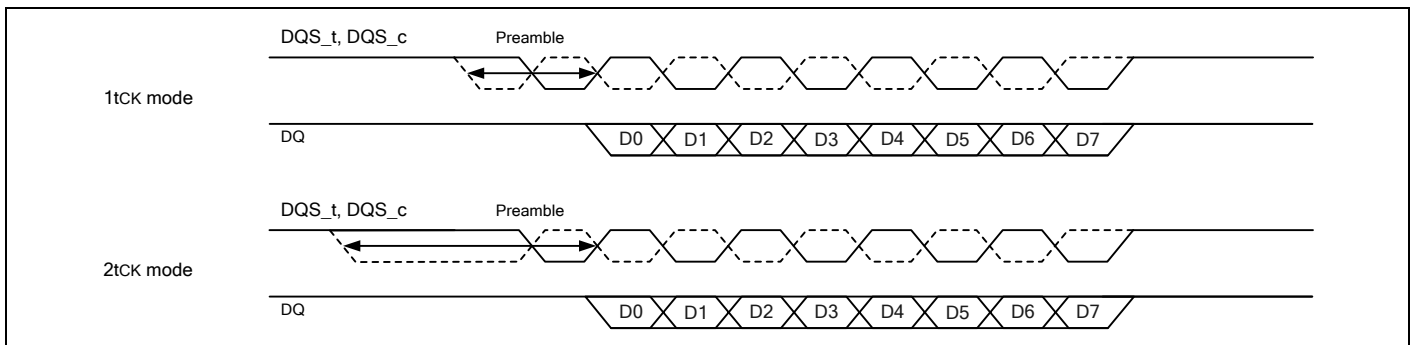

Figure 63 – 1tCK vs. 2tCK WRITE Preamble, tCCD=6 (AL=PL=0)

9.22.2 Read Preamble

DDR4 supports a programmable read preamble. The 1tCK and 2tCK Read preamble is selected via MR4 A[11]. Read preamble modes of 1tCK and 2tCK are shown as follows:



9.22.3 Read Preamble Training

Read Preamble Training, shown below, can be enabled via MR4 A[10] when the DRAM is in the MPR mode. Read Preamble Training is illegal if DRAM is not in the MPR mode. The Read Preamble Training can be used for read leveling.

1. READ preamble training is entered via an MRS command (MR4 A[10] = 1 is enabled and MR4 A[10] = 0 is disabled). After the MRS command is issued to enable READ preamble training, the DRAM DQS signals are driven to a valid level by the time tSDO is satisfied. During this time, the data bus DQ signals are held quiet, that is, driven HIGH.
2. The DQS_t signal remains driven LOW and the DQS_c signal remains driven HIGH until an MPR Page0 READ command is issued (MPR0 through MPR3 determine which pattern is used).
3. When CAS latency (CL) has expired, the DQS signals will toggle normally depending on the burst length setting.
4. To exit READ preamble training mode, an MRS command must be issued, MR4 A[10] = 0.

Illegal READ commands, any command during the READ process or initiating the READS process, are not allowed during Read Preamble Training.

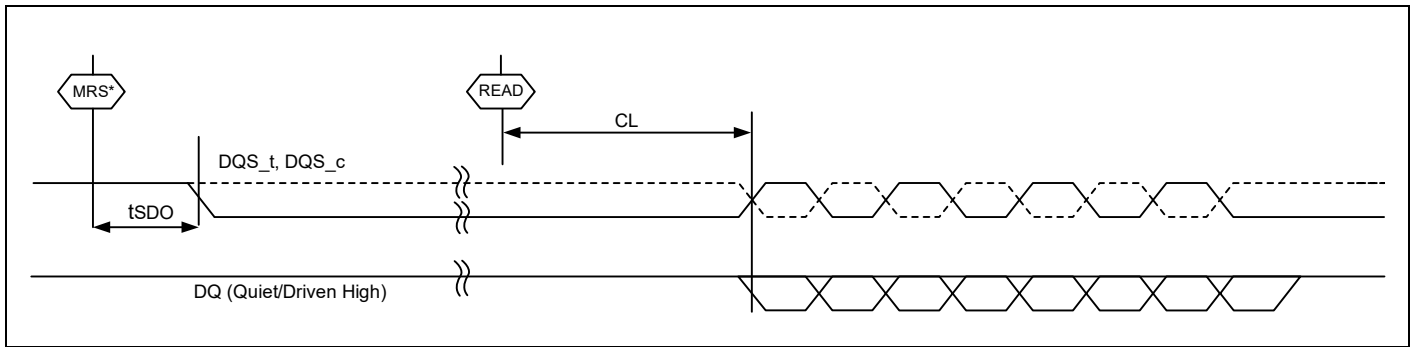

Note: Read Preamble Training mode is enabled by MR4 A[10] = 1.

Parameter	Symbol	DDR4-1600,1866,2133,2400		DDR4-2666,3200		Units	Note
		Min	Max	Min	Max		
Delay from MRS Command to Data Strobe Drive Out	tSDO	-	tMOD+9nS	-	tMOD+9nS		

9.23 Postamble

9.23.1 Read Postamble

DDR4 will support a fixed read postamble.

Read postamble of nominal 0.5tCK for preamble modes 1, 2 tCK are shown below:

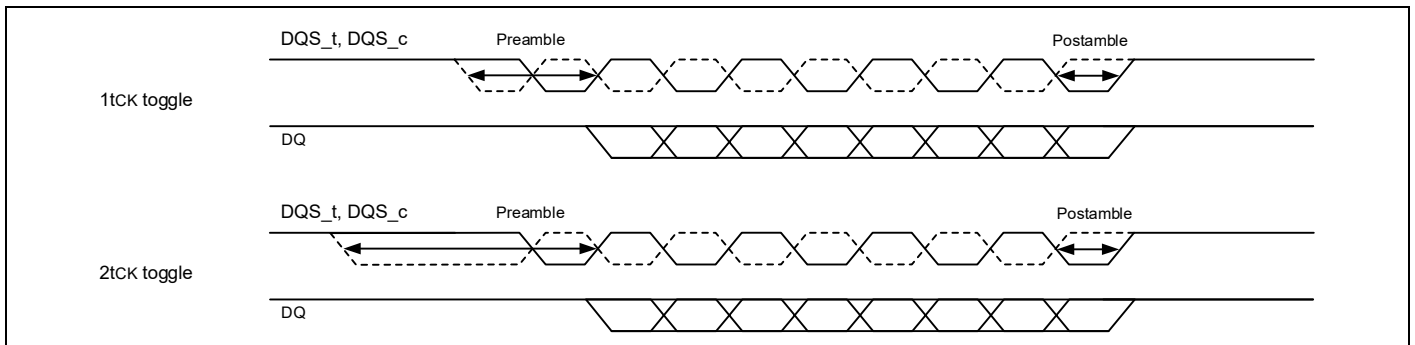

9.23.2 Write Postamble

DDR4 will support a fixed Write postamble.

Write postamble nominal is 0.5tCK for preamble modes 1, 2 tCK are shown below:

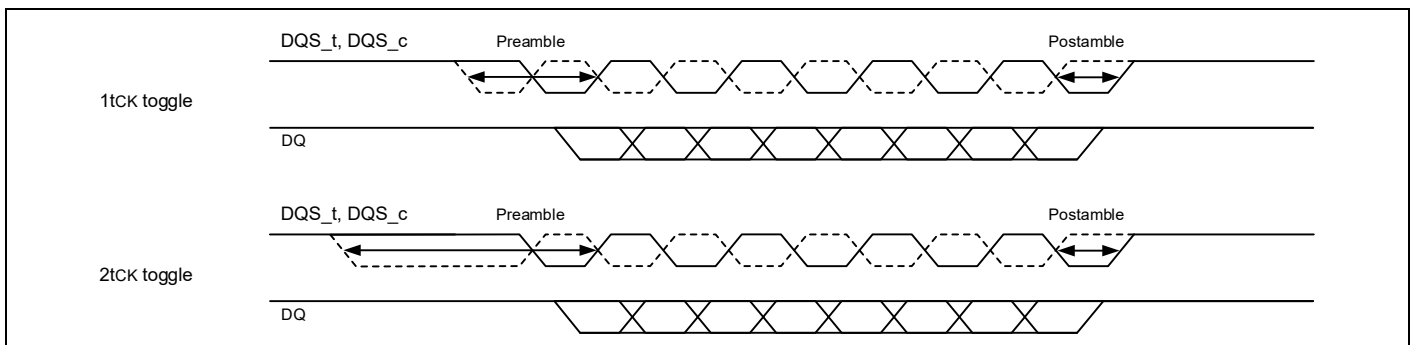



9.24 ACTIVATE Command

The ACTIVATE command is used to open (or activate) a row in a particular bank for a subsequent access. The value on the BG0 input selects the bank group; the BA0-BA1 input selects the bank within the bank group, and the address provided on A0-A14 input selects the row. This row remains active (or open) for accesses until a precharge command is issued to that bank or a precharge all command is issued. A bank must be precharged before opening a different row in the same bank.

9.25 Precharge Command

The PRECHARGE command is used to deactivate the open row in a particular bank or the open row in all banks. The bank(s) will be available for a subsequent row activation a specified time (tRP) after the PRECHARGE command is issued, except in the case of concurrent auto precharge, where a READ or WRITE command to a different bank is allowed as long as it does not interrupt the data transfer in the current bank and does not violate any other timing parameters. Once a bank has been precharged, it is in the idle state and must be activated prior to any READ or WRITE commands being issued to that bank. A PRECHARGE command is allowed if there is no open row in that bank (idle state) or if the previously open row is already in the process of precharging. However, the precharge period will be determined by the last PRECHARGE command issued to the bank.

If A10 is high when Read or Write command is issued, then auto precharge function is engaged. This feature allows the precharge operation to be partially or completely hidden during burst read cycles (dependent upon CAS latency) thus improving system performance for random data access. The RAS lockout circuit internally delays the precharge operation until the array restore operation has been completed (tRAS satisfied) so that the auto precharge command may be issued with any read. Auto precharge is also implemented during Write commands. The precharge operation engaged by the Auto precharge command will not begin until the last data of the burst write sequence is properly stored in the memory array. The bank will be available for a subsequent row activation a specified time (tRP) after hidden PRECHARGE command (Auto Precharge) is issued to that bank.

9.26 Read Operation

9.26.1 READ Timing Definitions

Read timing shown in this section is applied when the DLL is enabled and locked.

Rising data strobe edge parameters:

- tDQSCK min/max describes the allowed range for a rising data strobe edge relative to CK_t, CK_c.
- tDQSCK is the actual position of a rising strobe edge relative to CK_t, CK_c.
- tQSH describes the DQS_t, DQS_c differential output high time.
- tDQSQ describes the latest valid transition of the associated DQ pins.
- tQH describes the earliest invalid transition of the associated DQ pins.

Falling data strobe edge parameters:

- tQSL describes the DQS_t, DQS_c differential output low time.
- tDQSQ describes the latest valid transition of the associated DQ pins.
- tQH describes the earliest invalid transition of the associated DQ pins.

tDQSQ; both rising/falling edges of DQS, no tAC defined.

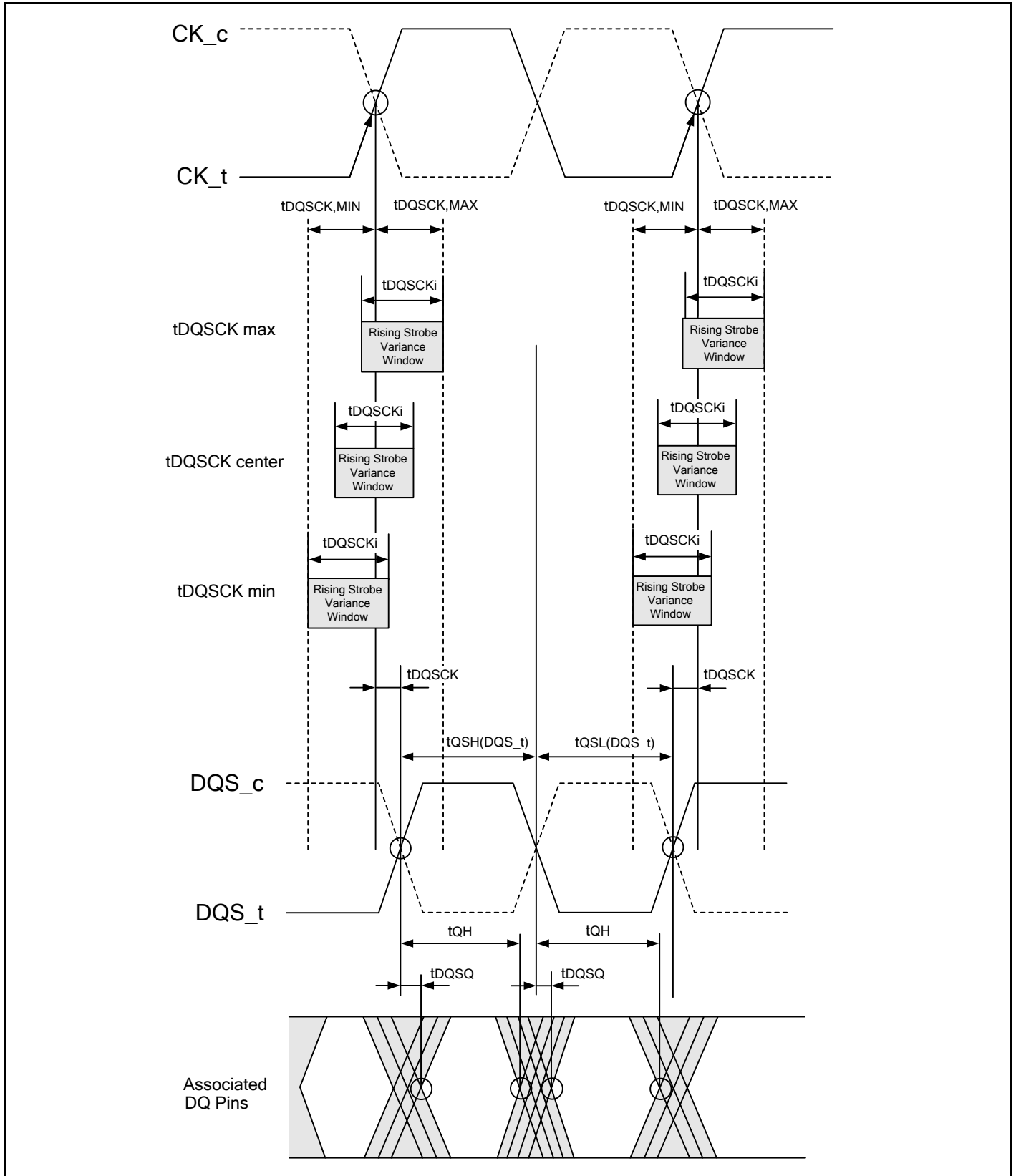

Figure 64 – READ Timing Definition



9.26.1.1 READ Timing; Clock to Data Strobe relationship

Clock to Data Strobe relationship is shown in Figure 65 and is applied when the DLL is enabled and locked.

Rising data strobe edge parameters:

tDQSCK min/max describes the allowed range for a rising data strobe edge relative to CK_t, CK_c.

tDQSCK is the actual position of a rising strobe edge relative to CK_t, CK_c.

tQSH describes the data strobe high pulse width.

Falling data strobe edge parameters:

- tQSL describes the data strobe low pulse width.

- tLZ(DQS), tHZ(DQS) for preamble/postamble.

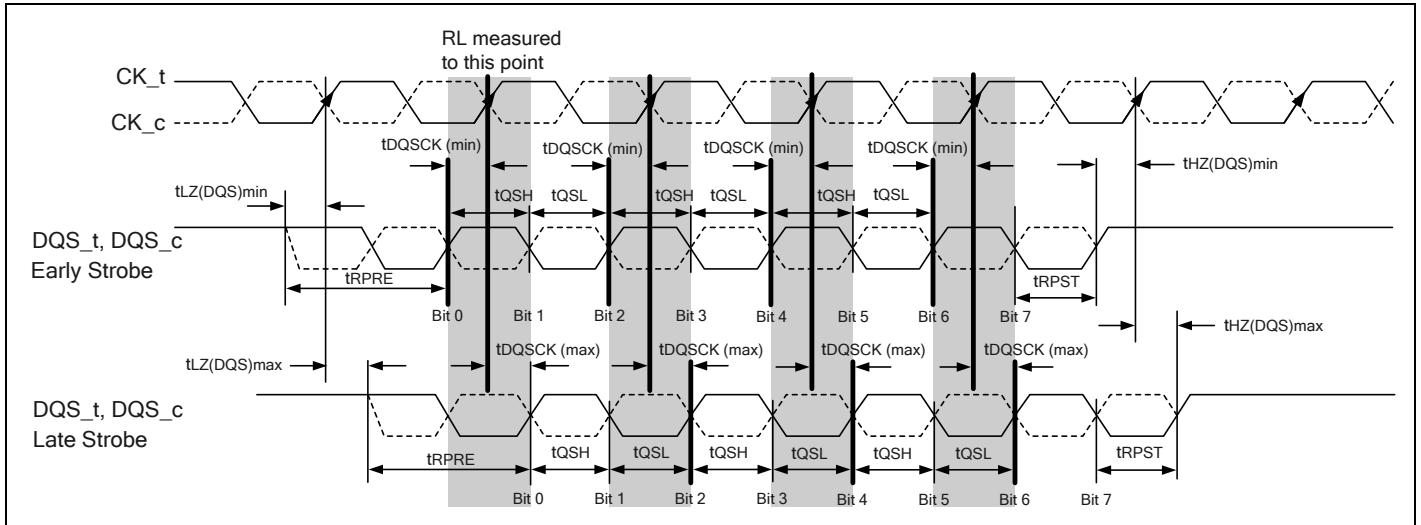

Notes:

1. Within a burst, rising strobe edge can be varied within tDQSCK_i while at the same voltage and temperature. However incorporate the device, voltage and temperature variation, rising strobe edge variance window, tDQSCK_i can shift between tDQSCK(min) and tDQSCK(max). A timing of this window's right inside edge (latest) from rising CK_t, CK_c is limited by a device's actual tDQSCK(max). A timing of this window's left inside edge (earliest) from rising CK_t, CK_c is limited by tDQSCK(min).
2. Notwithstanding note 1, a rising strobe edge with tDQSCK(max) at T(n) cannot be immediately followed by a rising strobe edge with tDQSCK(min) at T(n+1). This is because other timing relationships (tQSH, tQSL) exist:
if $tDQSCK(n+1) < 0$:
$$tDQSCK(n) < 1.0 tCK - (tQSH_{min} + tQSL_{min}) - |tDQSCK(n+1)|$$
3. The DQS_t, DQS_c differential output high time is defined by tQSH and the DQS_t, DQS_c differential output low time is defined by tQSL.
4. Likewise, tLZ(DQS)_{min} and tHZ(DQS)_{min} are not tied to tDQSCK_{min} (early strobe case) and tLZ(DQS)_{max} and tHZ(DQS)_{max} are not tied to tDQSCK_{max} (late strobe case).
5. The minimum pulse width of read preamble is defined by tRPRE(min).
6. The maximum read postamble is bound by tDQSCK(min) plus tQSH(min) on the left side and tHZDQS(max) on the right side.
7. The minimum pulse width of read postamble is defined by tRPST(min).
8. The maximum read preamble is bound by tLZDQS(min) on the left side and tDQSCK(max) on the right side.

Figure 65 – Clock to Data Strobe Relationship



9.26.1.2 READ Timing; Data Strobe to Data relationship

The Data Strobe to Data relationship is shown in Figure 66 and is applied when the DLL is enabled and locked.

Rising data strobe edge parameters:

tDQSQ describes the latest valid transition of the associated DQ pins.

tQH describes the earliest invalid transition of the associated DQ pins.

Falling data strobe edge parameters:

tDQSQ describes the latest valid transition of the associated DQ pins.

tQH describes the earliest invalid transition of the associated DQ pins.

tDQSQ; both rising/falling edges of DQS, no tAC defined.

Data Valid Window:

tDVWd is the Data Valid Window per device per UI and is derived from (tQH - tDQSQ) of each UI on a given DRAM. This parameter will be characterized and guaranteed by design.

tDVWp is Data Valid Window per pin per UI and is derived from (tQH - tDQSQ) of each UI on a pin of a given DRAM. This parameter will be characterized and guaranteed by design.

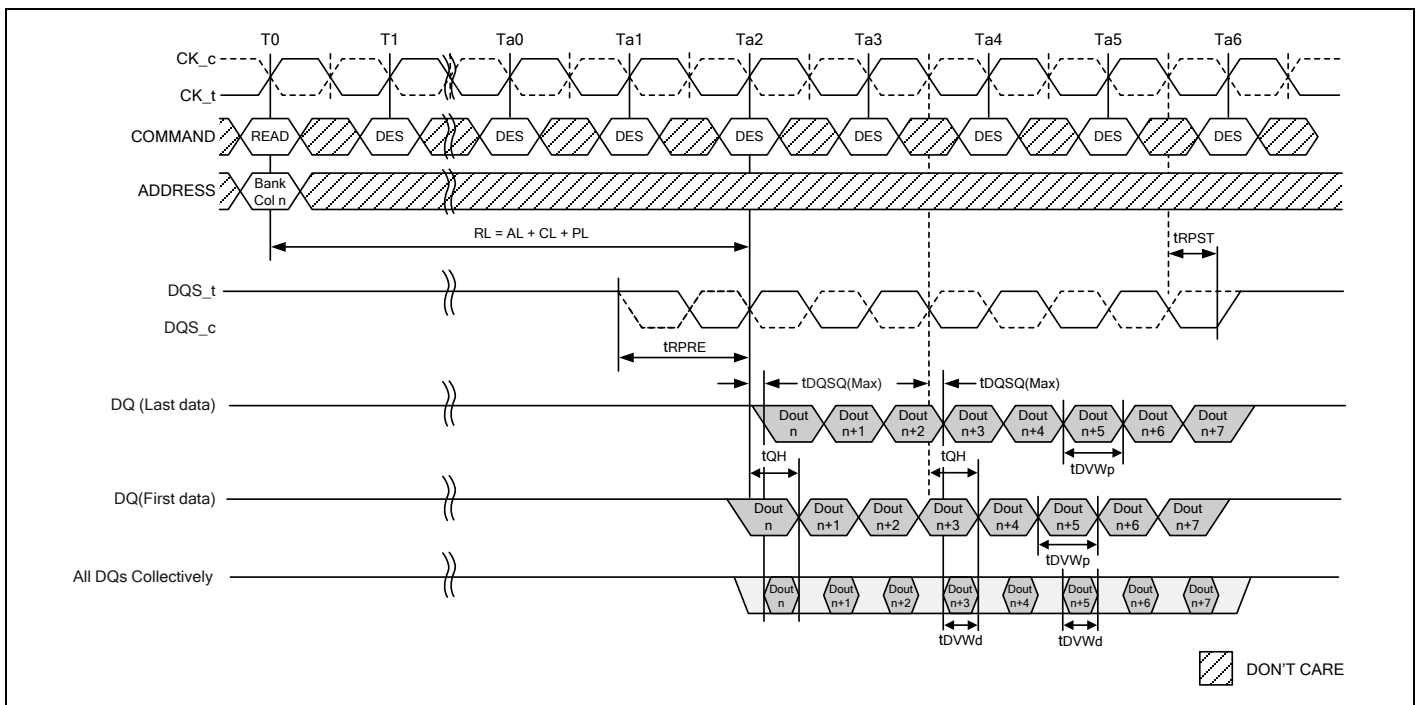

Notes:

1. BL = 8, AL = 0, CL = 11, Preamble = 1tCK.
2. Dout n = data-out from column n.
3. DES commands are shown for ease of illustration; other commands may be valid at these times.
4. BL8 setting activated by either MR0 A[1:0] = 00 or MR0 A[1:0] = 01 and A12 = 1 during READ command at T0.
5. Output timings are referenced to VDDQ, and DLL on for locking.
6. tDQSQ defines the skew between DQS_t, DQS_c to Data and does not define DQS_t, DQS_c to Clock.
7. Early Data transitions may not always happen at the same DQ. Data transitions of a DQ can vary (either early or late) within a burst.

Figure 66 – Data Strobe to Data Relationship



9.26.1.3 tLZ(DQS), tLZ(DQ), tHZ(DQS), tHZ(DQ) Calculation

tHZ and tLZ transitions occur in the same time window as valid data transitions. These parameters are referenced to a specific voltage level that specifies when the device output is no longer driving tHZ(DQS) and tHZ(DQ), or begins driving tLZ(DQS), tLZ(DQ). Figure 67 shows a method to calculate the point when the device is no longer driving tHZ(DQS) and tHZ(DQ), or begins driving tLZ(DQS), tLZ(DQ), by measuring the signal at two different voltages. The actual voltage measurement points are not critical as long as the calculation is consistent. The parameters tLZ(DQS), tLZ(DQ), tHZ(DQS), and tHZ(DQ) are defined as single ended.

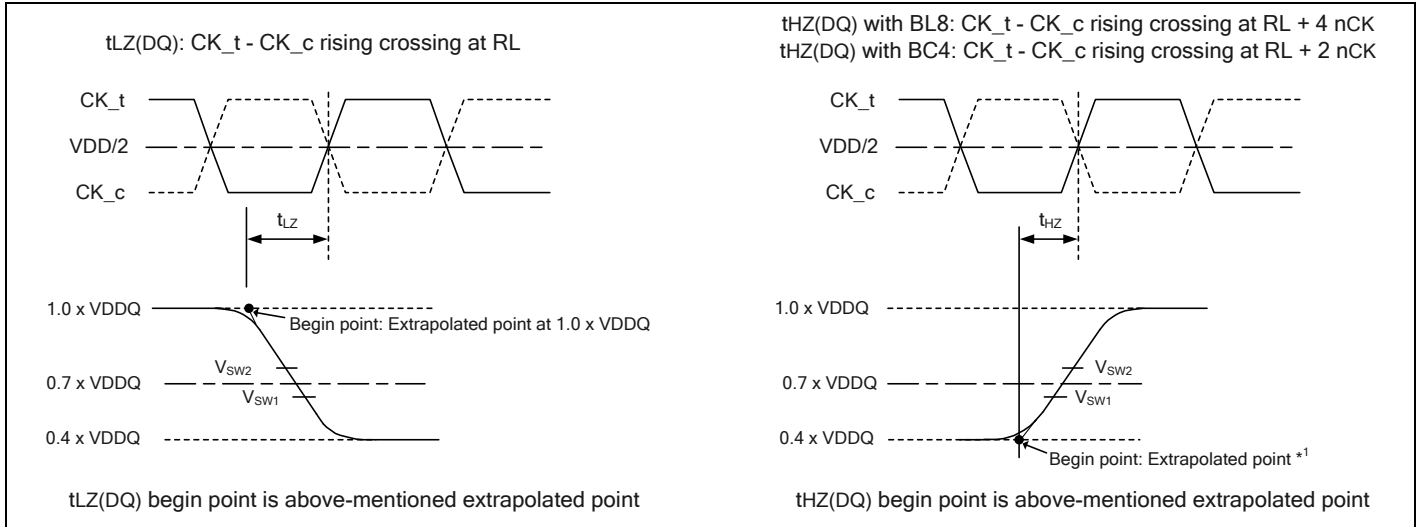

Note 1: Extrapolated point (Low Level) = $VDDQ / (50 + 34) \times 34$
 = $VDDQ \times 0.40$
 - A driver impedance: $RZQ/7 = (34\Omega)$
 - An effective test load: 50Ω to $VTT = VDDQ$

Figure 67 – tLZ(DQ) and tHZ(DQ) method for calculating transitions and begin points

Table 40 – Reference Voltage for tLZ(DQ), tHZ(DQ) Timing Measurements

Measured Parameter	Measured Parameter Symbol	Vsw1[V]	Vsw2[V]	Note
DQ low-impedance time from CK_t, CK_c	tLZ(DQ)	$(0.70 - 0.04) \times VDDQ$	$(0.70 + 0.04) \times VDDQ$	
DQ high impedance time from CK_t, CK_c	tHZ(DQ)	$(0.70 - 0.04) \times VDDQ$	$(0.70 + 0.04) \times VDDQ$	

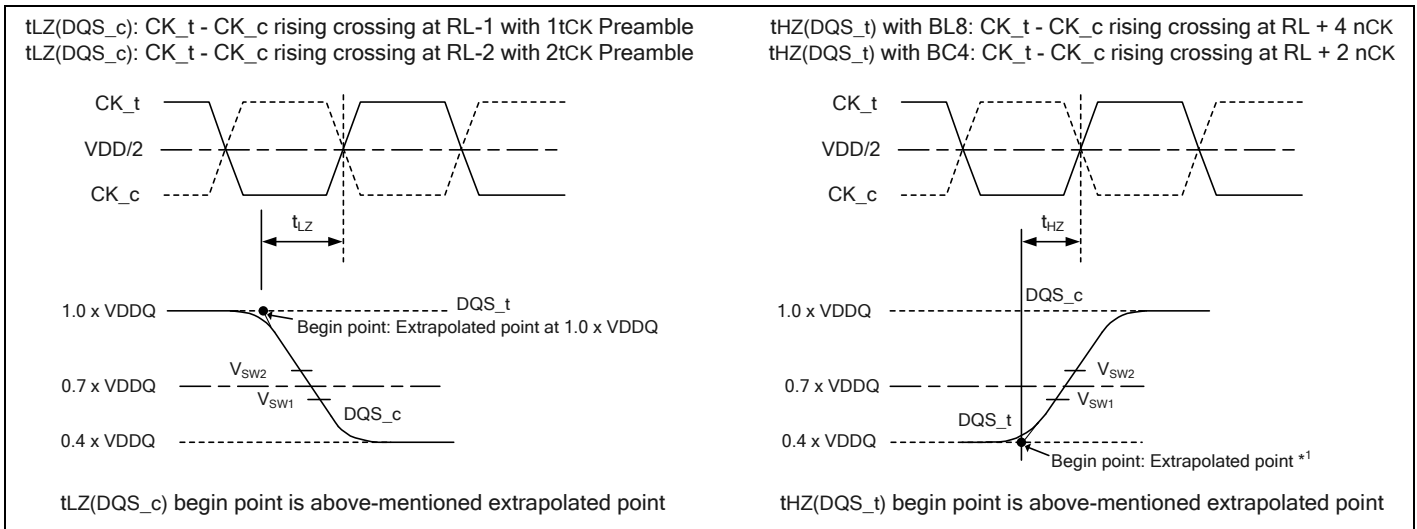

Note 1: Extrapolated point (Low Level) = $VDDQ / (50 + 34) \times 34$
= $VDDQ \times 0.40$

- A driver impedance: $RZQ/7 = (34\Omega)$
- An effective test load: 50Ω to $V_{TT} = VDDQ$

Figure 68 – tLZ(DQS_c) and tHZ(DQS_t) method for calculating transitions and begin points

Table 41 – Reference Voltage for tLZ(DQS_c), tHZ(DQS_t) Timing Measurements

Measured Parameter	Measured Parameter Symbol	Vsw1[V]	Vsw2[V]	Note
DQS_c low-impedance time from CK_t, CK_c	tLZ(DQS_c)	$(0.70 - 0.04) \times VDDQ$	$(0.70 + 0.04) \times VDDQ$	
DQS_t high impedance time from CK_t, CK_c	tHZ(DQS_t)	$(0.70 - 0.04) \times VDDQ$	$(0.70 + 0.04) \times VDDQ$	



9.26.1.4 tRPRE Calculation

The method for calculating differential pulse widths for tRPRE is shown in Figure 69.

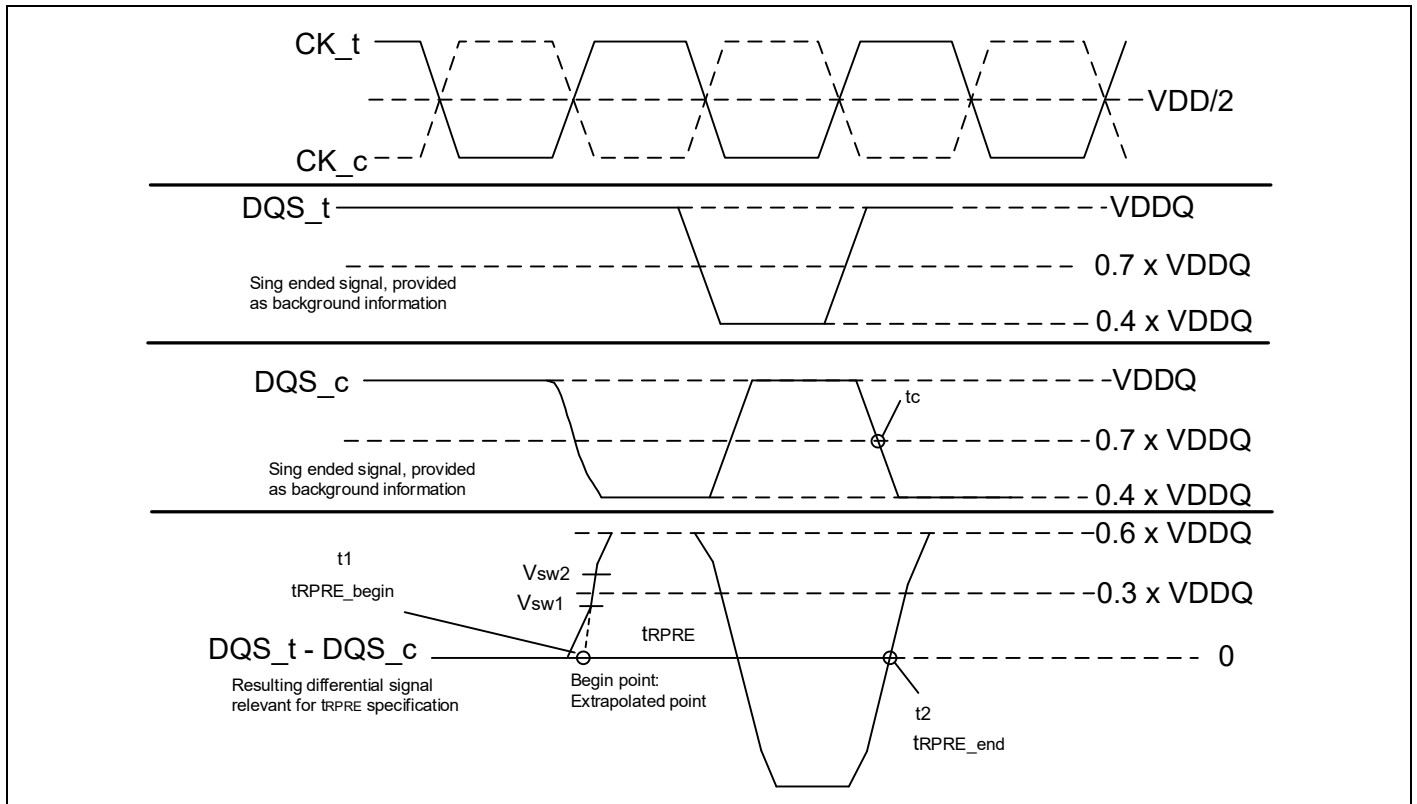

Note: Low Level of DQS_t and DQS_c = $VDDQ / (50 + 34) \times 34$
 = $VDDQ \times 0.40$

- A driver impedance: $RZQ/7 = (34\Omega)$
- An effective test load: 50Ω to $VTT = VDDQ$

Figure 69 – Method for calculating tRPRE transitions and endpoints

Table 42 – Reference Voltage for tRPRE Timing Measurements

Measured Parameter	Measured Parameter Symbol	Vsw1[V]	Vsw2[V]	Note
DQS _t , DQS _c differential READ Preamble	tRPRE	$(0.30 - 0.04) \times VDDQ$	$(0.30 + 0.04) \times VDDQ$	



9.26.1.5 tRPST Calculation

The method for calculating differential pulse widths for tRPST is shown in Figure 70.

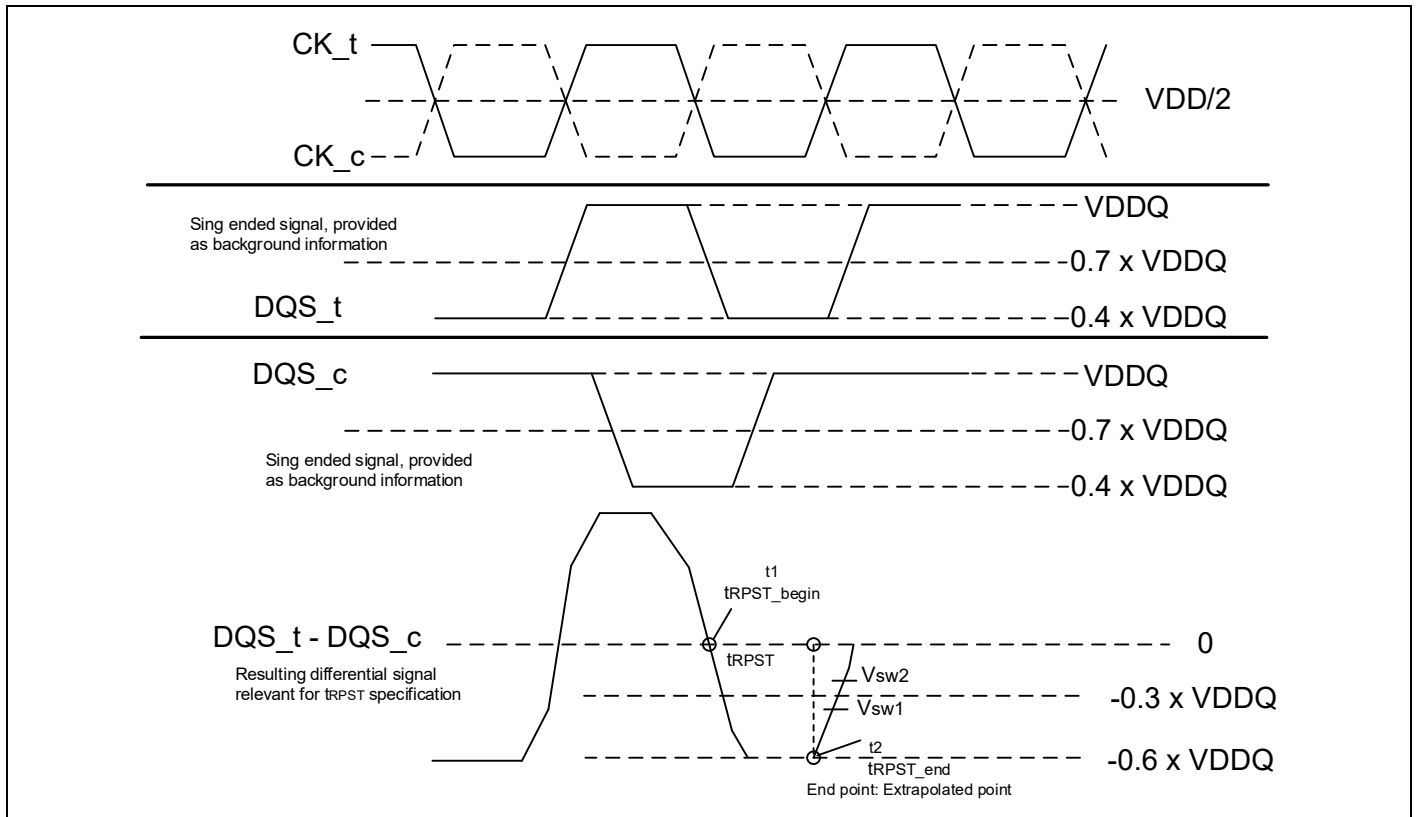

Note: Low Level of DQS_t and DQS_c = $VDDQ / (50 + 34) \times 34$
 = $VDDQ \times 0.40$

- A driver impedance: $RZQ/7 = (34\Omega)$
- An effective test load: 50Ω to $V_{TT} = VDDQ$

Figure 70 – Method for calculating tRPST transitions and endpoints

Table 43 – Reference Voltage for tRPST Timing Measurements

Measured Parameter	Measured Parameter Symbol	V _{sw1} [V]	V _{sw2} [V]	Note
DQS _t , DQS _c differential READ Postamble	tRPST	$(-0.30 - 0.04) \times VDDQ$	$(-0.30 + 0.04) \times VDDQ$	



9.26.2 READ Burst Operation

During a READ or WRITE command, DDR4 will support BC4 and BL8 on the fly using address A12 during the READ or WRITE (AUTO PRECHARGE can be enabled or disabled).

A12 = 0: BC4 (BC4 = burst chop)

A12 = 1: BL8

A12 is used only for burst length control, not as a column address.

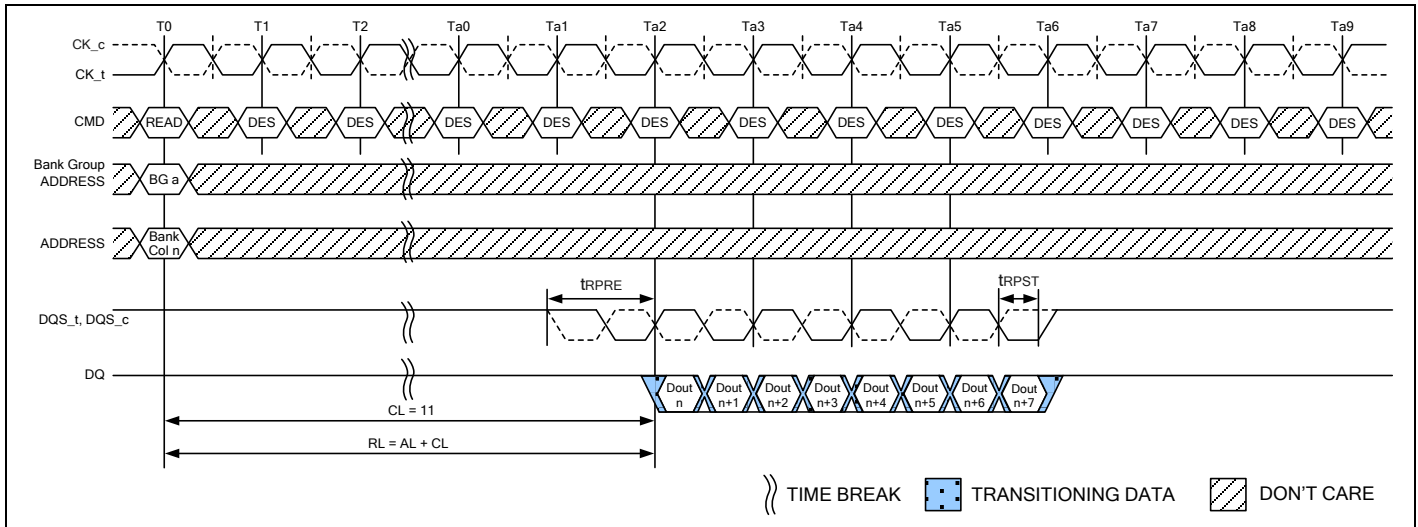

Notes:

1. BL = 8, AL = 0, CL = 11, Preamble = 1tCK
2. Dout n = data-out from column n.
3. DES commands are shown for ease of illustration; other commands may be valid at these times.
4. BL8 setting activated by either MR0 A[1:0] = 00 or MR0 A[1:0] = 01 and A12 = 1 during READ command at T0.
5. CA Parity = Disable, CS to CA Latency = Disable, Read DBI = Disable

Figure 71 – READ Burst Operation RL = 11 (AL = 0, CL = 11, BL8)

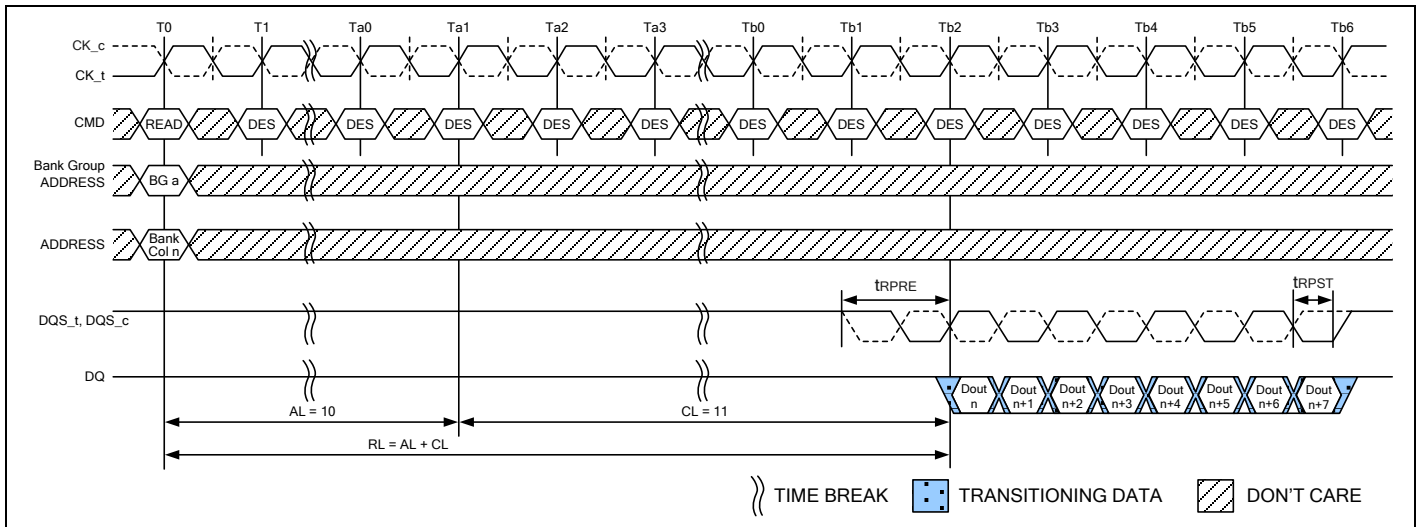

Notes:

1. BL = 8, RL = 21, AL = (CL-1), CL = 11, Preamble = 1tCK
2. Dout n = data-out from column n.
3. DES commands are shown for ease of illustration; other commands may be valid at these times.
4. BL8 setting activated by either MR0 A[1:0] = 00 or MR0 A[1:0] = 01 and A12 = 1 during READ command at T0.
5. CA Parity = Disable, CS to CA Latency = Disable, Read DBI = Disable

Figure 72 – READ Burst Operation RL = 21 (AL = 10, CL = 11, BL8)

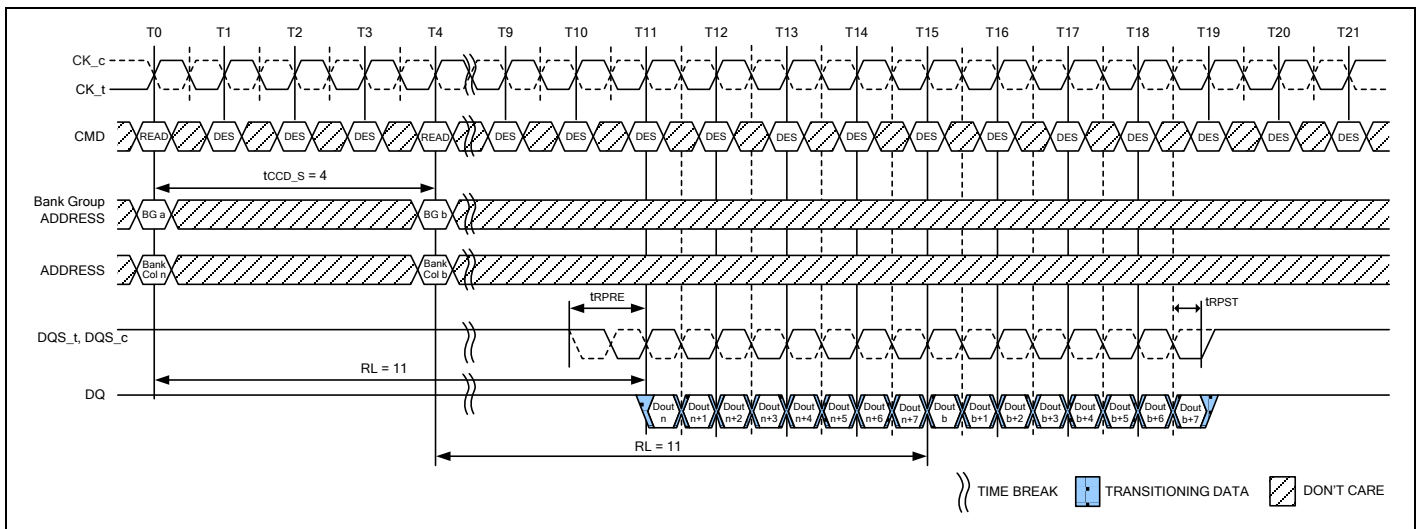

Notes:

1. BL = 8, AL = 0, CL = 11, Preamble = 1tCK
2. Dout n (or b) = data-out from column n (or column b).
3. DES commands are shown for ease of illustration; other commands may be valid at these times.
4. BL8 setting activated by either MR0 A[1:0] = 00 or MR0 A[1:0] = 01 and A12 = 1 during READ command at T0 and T4.
5. CA Parity = Disable, CS to CA Latency = Disable, Read DBI = Disable

Figure 73 – Consecutive READ (BL8) with 1tCK Preamble in Different Bank Group

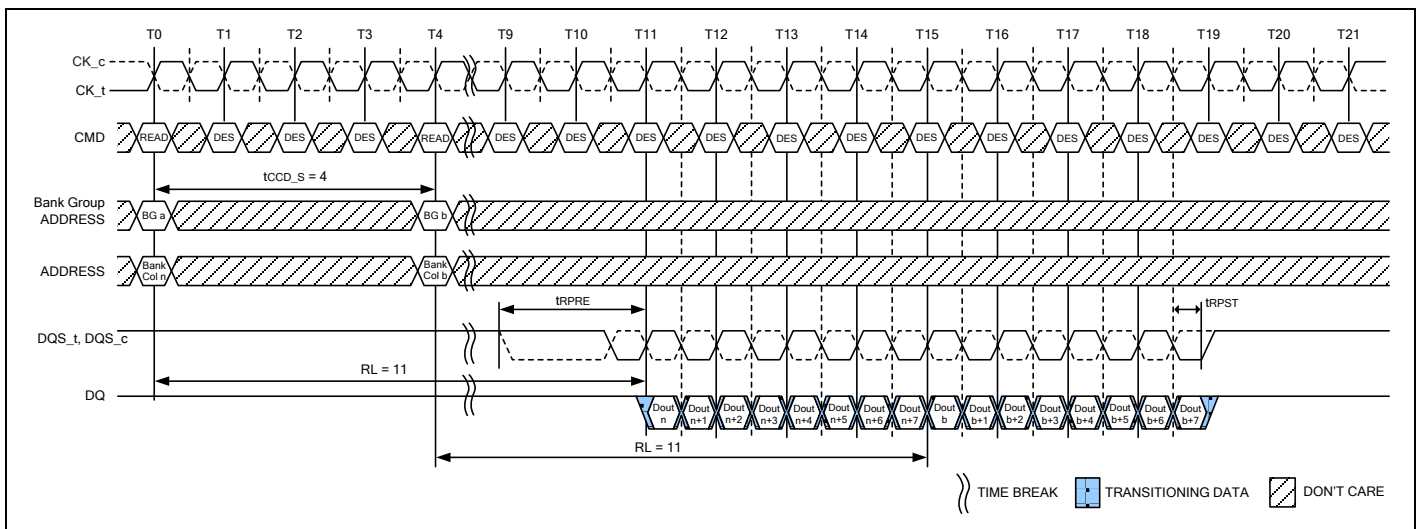

Notes:

1. BL = 8, AL = 0, CL = 11, Preamble = 2tCK
2. Dout n (or b) = data-out from column n (or column b).
3. DES commands are shown for ease of illustration; other commands may be valid at these times.
4. BL8 setting activated by either MR0 A[1:0] = 00 or MR0 A[1:0] = 01 and A12 = 1 during READ command at T0 and T4.
5. CA Parity = Disable, CS to CA Latency = Disable, Read DBI = Disable

Figure 74 – Consecutive READ (BL8) with 2tCK Preamble in Different Bank Group

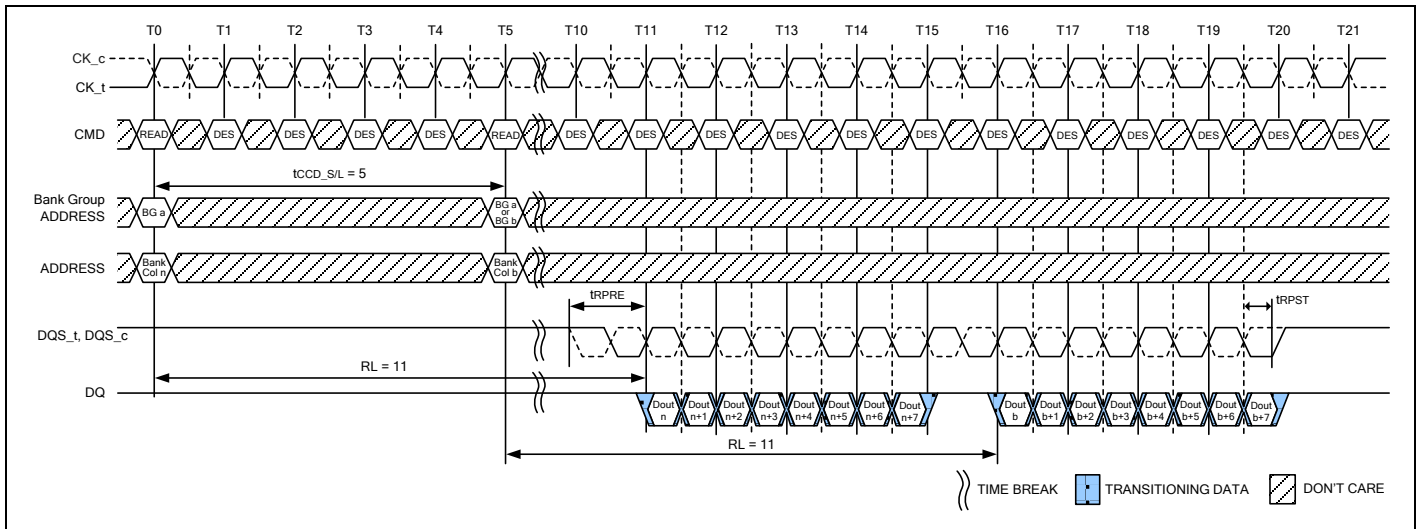

Notes:

1. BL = 8, AL = 0, CL = 11, Preamble = 1tCK, tCCD_S/L = 5
2. Dout n (or b) = data-out from column n (or column b).
3. DES commands are shown for ease of illustration; other commands may be valid at these times.
4. BL8 setting activated by either MR0 A[1:0] = 00 or MR0 A[1:0] = 01 and A12 = 1 during READ command at T0 and T5.
5. CA Parity = Disable, CS to CA Latency = Disable, Read DBI = Disable

Figure 75 – Nonconsecutive READ (BL8) with 1tCK Preamble in Same or Different Bank Group

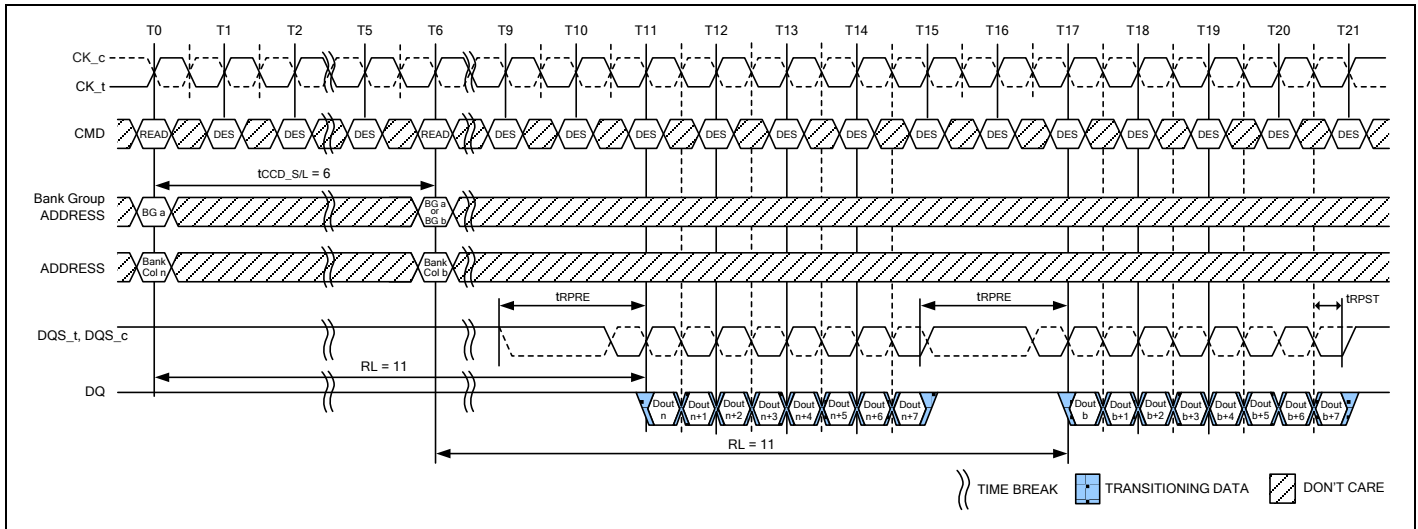

Notes:

1. BL = 8, AL = 0, CL = 11, Preamble = 2tCK, tCCD_S/L = 6
2. Dout n (or b) = data-out from column n (or column b).
3. DES commands are shown for ease of illustration; other commands may be valid at these times.
4. BL8 setting activated by either MR0 A[1:0] = 00 or MR0 A[1:0] = 01 and A12 = 1 during READ command at T0 and T6.
5. CA Parity = Disable, CS to CA Latency = Disable, Read DBI = Disable
6. tCCD_S/L = 5 isn't allowed in 2tCK preamble mode.

Figure 76 – Nonconsecutive READ (BL8) with 2tCK Preamble in Same or Different Bank Group

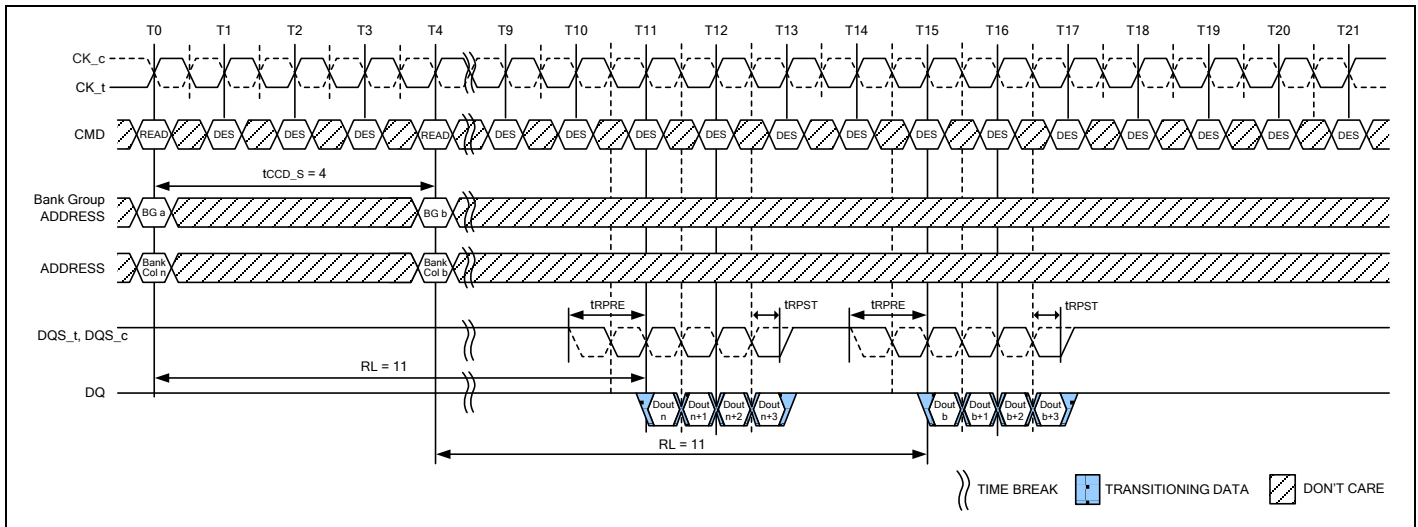

Notes:

1. BL = 8, AL = 0, CL = 11, Preamble = 1tCK
2. Dout n (or b) = data-out from column n (or column b).
3. DES commands are shown for ease of illustration; other commands may be valid at these times.
4. BC4 setting activated by either MR0 A[1:0] = 10 or MR0 A[1:0] = 01 and A12 = 0 during READ command at T0 and T4.
5. CA Parity = Disable, CS to CA Latency = Disable, Read DBI = Disable

Figure 77 – READ (BC4) to READ (BC4) with 1tCK Preamble in Different Bank Group

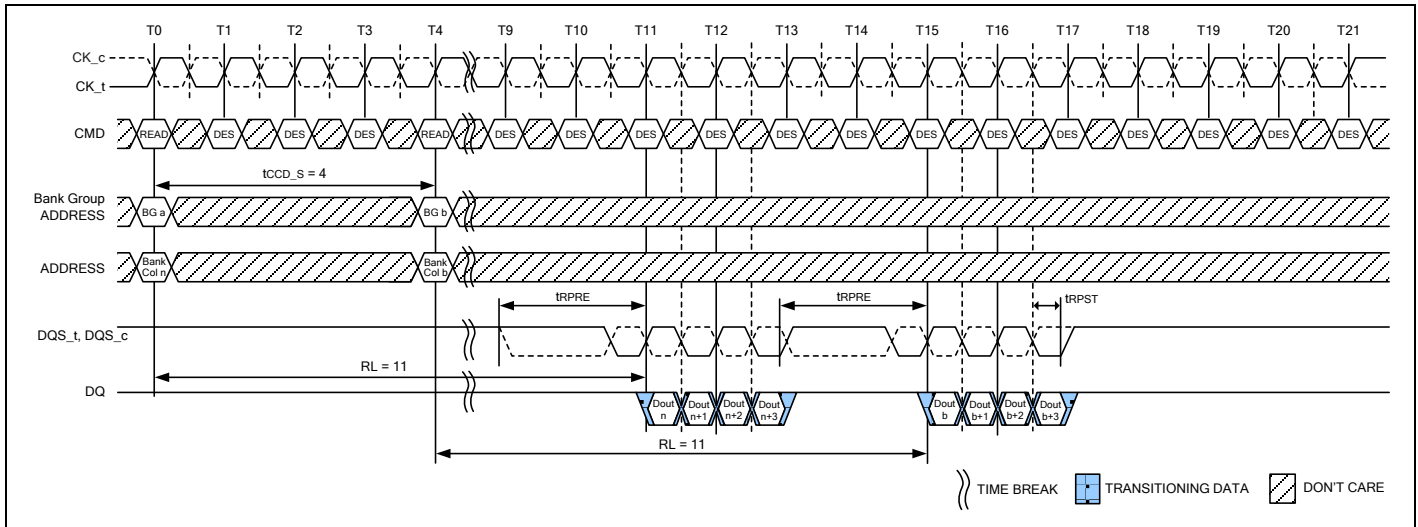

Notes:

1. BL = 8, AL = 0, CL = 11, Preamble = 2tCK.
2. Dout n (or b) = data-out from column n (or column b).
3. DES commands are shown for ease of illustration; other commands may be valid at these times.
4. BC4 setting activated by either MR0 A[1:0] = 10 or MR0 A[1:0] = 01 and A12 = 0 during READ command at T0 and T4.
5. CA Parity = Disable, CS to CA Latency = Disable, Read DBI = Disable

Figure 78 – READ (BC4) to READ (BC4) with 2tCK Preamble in Different Bank Group

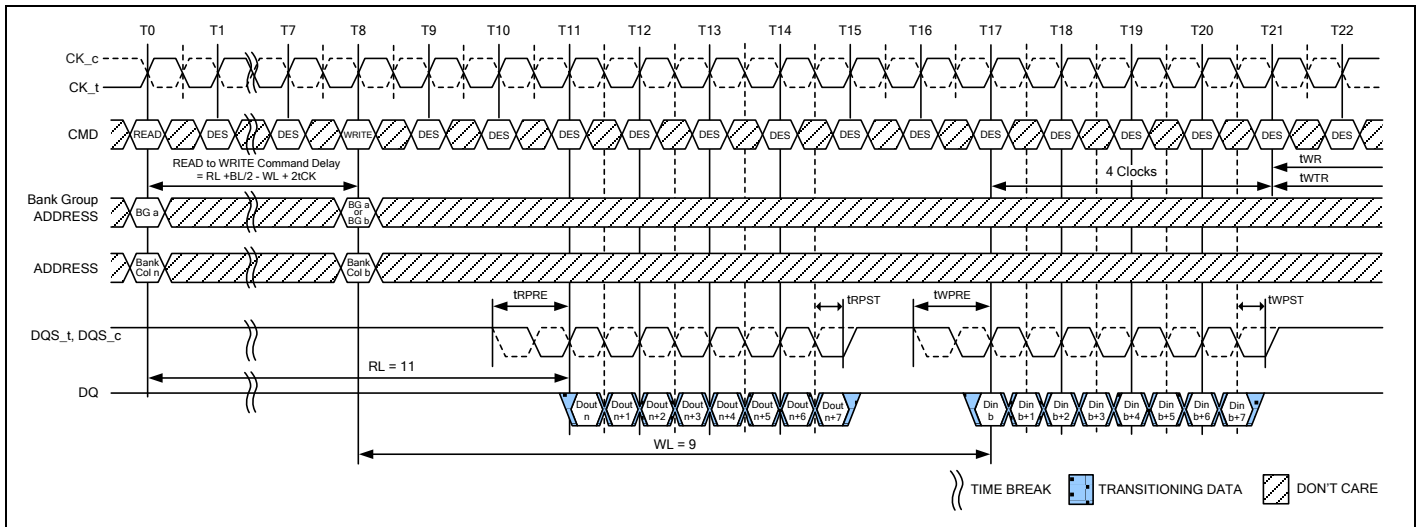

Notes:

1. BL = 8, RL = 11 (CL = 11, AL = 0), Read Preamble = 1tCK, WL = 9 (CWL = 9, AL = 0), Write Preamble = 1tCK
2. Dout n = data-out from column n, Din b = data-in to column b.
3. DES commands are shown for ease of illustration; other commands may be valid at these times.
4. BL8 setting activated by either MR0 A[1:0] = 00 or MR0 A[1:0] = 01 and A12 = 1 during READ command at T0 and WRITE command at T8.
5. CA Parity = Disable, CS to CA Latency = Disable, Read DBI = Disable, Write DBI = Disable, Write CRC = Disable.

Figure 79 – READ (BL8) to WRITE (BL8) with 1tCK Preamble in Same or Different Bank Group

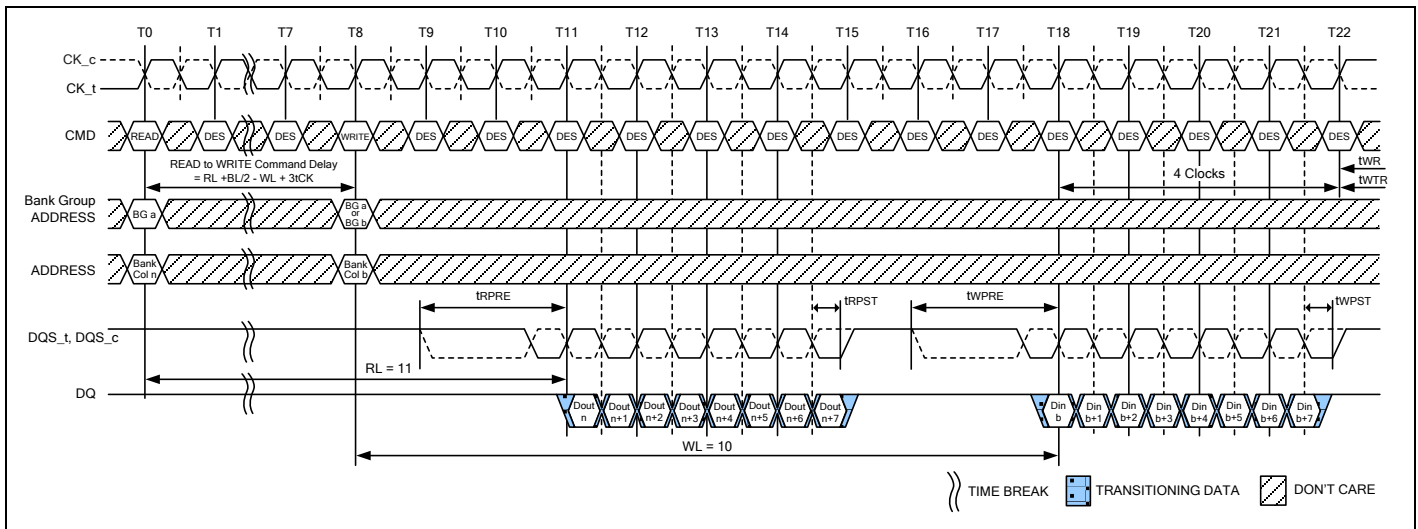

Notes:

1. BL = 8, RL = 11 (CL = 11, AL = 0), Read Preamble = 2tCK, WL = 10 (CWL = 9+1⁵, AL = 0), Write Preamble = 2tCK
2. Dout n = data-out from column n, Din b = data-in to column b.
3. DES commands are shown for ease of illustration; other commands may be valid at these times.
4. BL8 setting activated by either MR0 A[1:0] = 00 or MR0 A[1:0] = 01 and A12 = 1 during READ command at T0 and WRITE command at T8.
5. When operating in 2tCK Write Preamble Mode, CWL must be programmed to a value at least 1 clock greater than the lowest CWL setting.
6. CA Parity = Disable, CS to CA Latency = Disable, Read DBI = Disable, Write DBI = Disable, Write CRC = Disable.

Figure 80 – READ (BL8) to WRITE (BL8) with 2tCK Preamble in Same or Different Bank Group

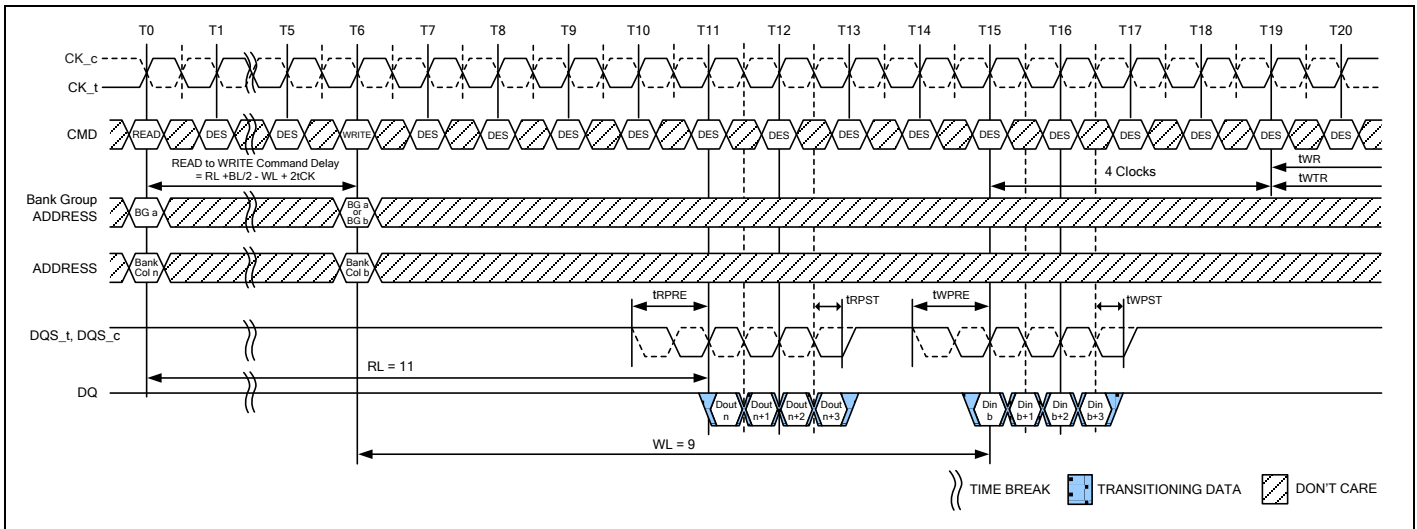

Notes:

1. BC = 4, RL = 11 (CL = 11, AL = 0), Read Preamble = 1tCK, WL = 9 (CWL = 9, AL = 0), Write Preamble = 1tCK
2. Dout n = data-out from column n, Din b = data-in to column b.
3. DES commands are shown for ease of illustration; other commands may be valid at these times.
4. BC4(OTF) setting activated by MR0 A[1:0] = 01 and A12 = 0 during READ command at T0 and WRITE command at T6.
5. CA Parity = Disable, CS to CA Latency = Disable, Read DBI = Disable, Write DBI = Disable, Write CRC = Disable.

Figure 81 – READ (BC4) OTF to WRITE (BC4) OTF with 1tCK Preamble in Same or Different Bank Group

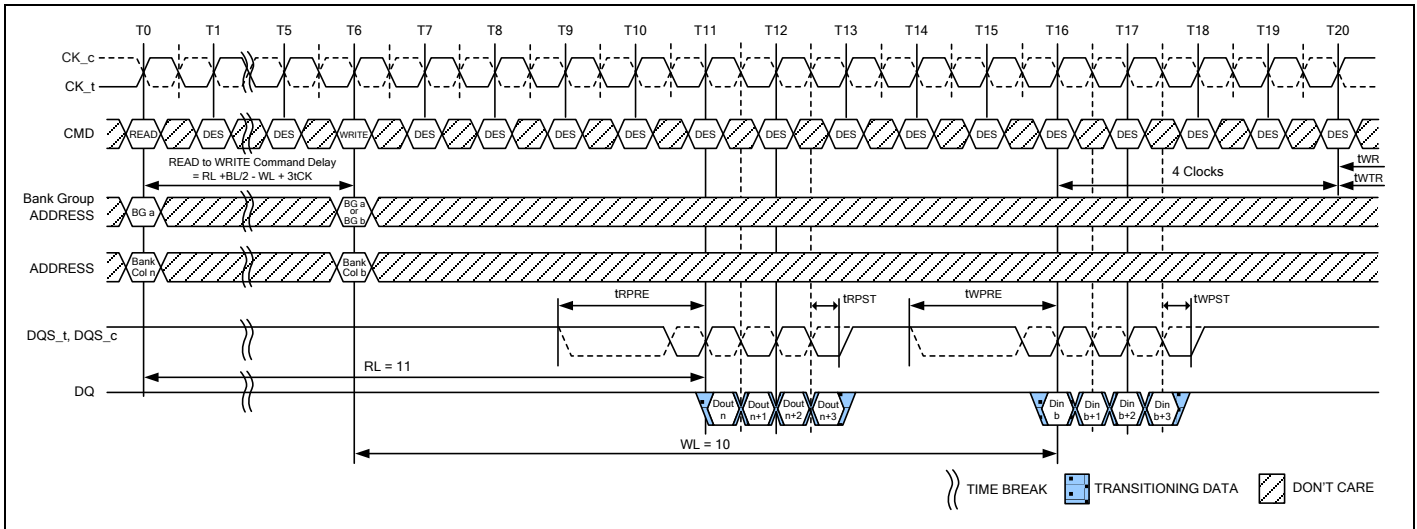

Notes:

1. BC = 4, RL = 11 (CL = 11, AL = 0), Read Preamble = 2tCK, WL = 10 (CWL = 9+1⁵, AL = 0), Write Preamble = 2tCK
2. Dout n = data-out from column n, Din b = data-in to column b.
3. DES commands are shown for ease of illustration; other commands may be valid at these times.
4. BC4(OTF) setting activated by MR0 A[1:0] = 01 and A12 = 0 during READ command at T0 and WRITE command at T6.
5. When operating in 2tCK Write Preamble Mode, CWL must be programmed to a value at least 1 clock greater than the lowest CWL setting.
6. CA Parity = Disable, CS to CA Latency = Disable, Read DBI = Disable, Write DBI = Disable, Write CRC = Disable

Figure 82 – READ (BC4) OTF to WRITE (BC4) OTF with 2tCK Preamble in Same or Different Bank Group

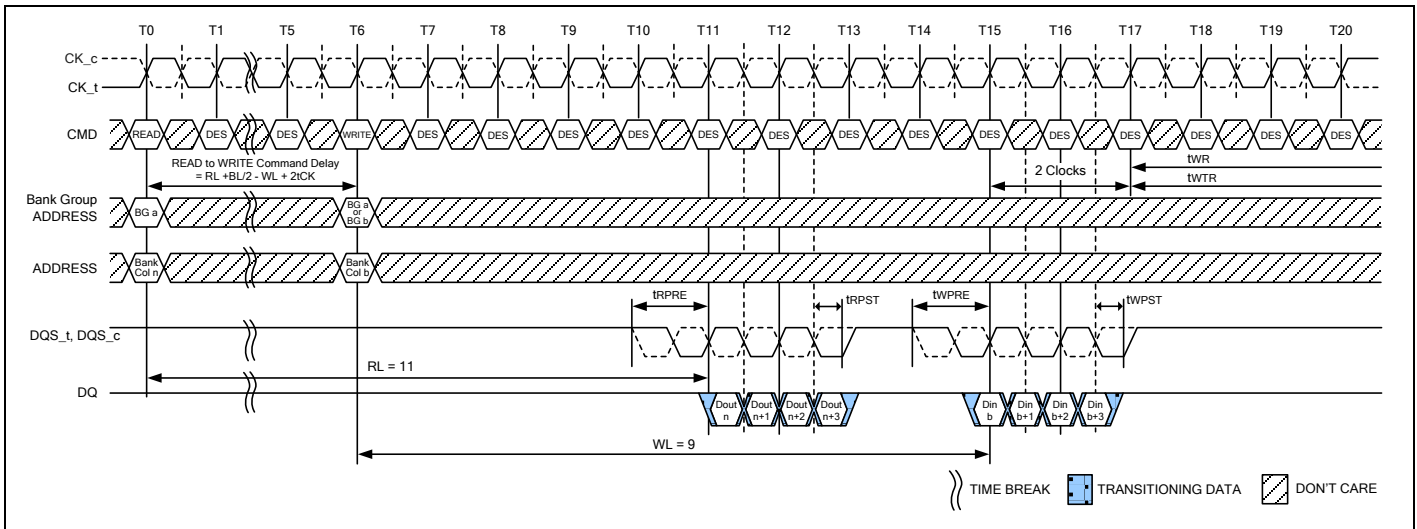

Notes:

1. BC = 4, RL = 11 (CL = 11, AL = 0), Read Preamble = 1tCK, WL = 9 (CWL = 9, AL = 0), Write Preamble = 1tCK
2. Dout n = data-out from column n, Din b = data-in to column b.
3. DES commands are shown for ease of illustration; other commands may be valid at these times.
4. BC4(Fixed) setting activated by MR0 A[1:0] = 10.
5. CA Parity = Disable, CS to CA Latency = Disable, Read DBI = Disable, Write DBI = Disable, Write CRC = Disable

Figure 83 – READ (BC4) Fixed to WRITE (BC4) Fixed with 1tCK Preamble in Same or Different Bank Group

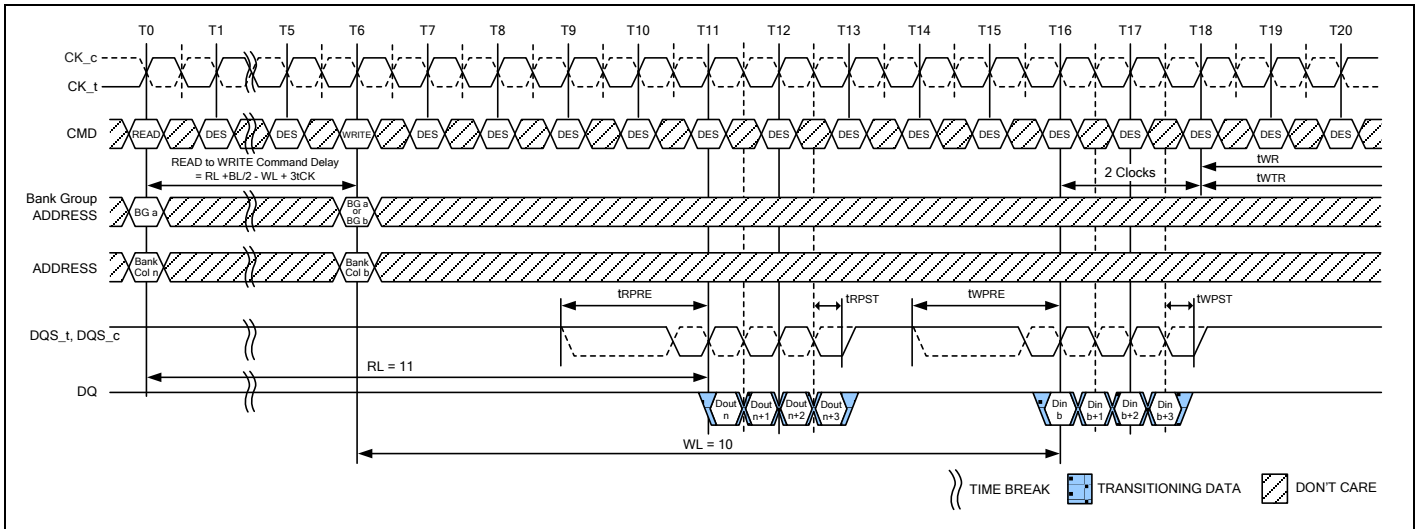

Notes:

1. BC = 4, RL = 11 (CL = 11, AL = 0), Read Preamble = 2tCK, WL = 10 (CWL = 9+1⁵, AL = 0), Write Preamble = 2tCK
2. Dout n = data-out from column n, Din b = data-in to column b.
3. DES commands are shown for ease of illustration; other commands may be valid at these times.
4. BC4(Fixed) setting activated by MR0 A[1:0] = 10.
5. When operating in 2tCK Write Preamble Mode, CWL must be programmed to a value at least 1 clock greater than the lowest CWL setting.
6. CA Parity = Disable, CS to CA Latency = Disable, Read DBI = Disable, Write DBI = Disable, Write CRC = Disable.

Figure 84 – READ (BC4) Fixed to WRITE (BC4) Fixed with 2tCK Preamble in Same or Different Bank Group

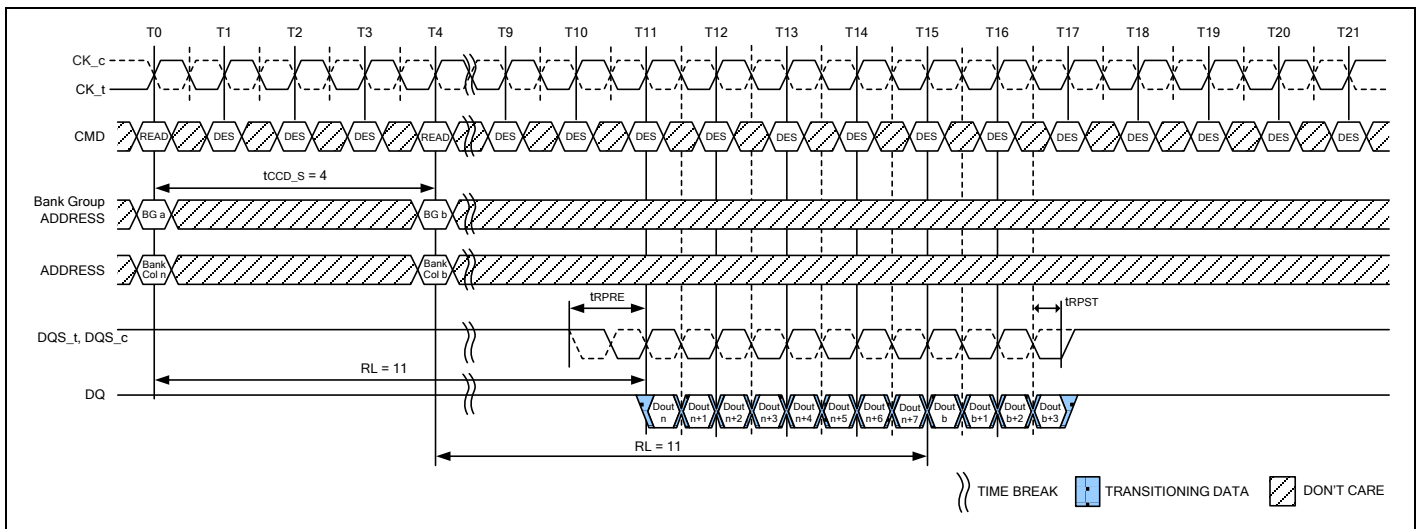

Notes:

1. BL = 8, AL = 0, CL = 11, Preamble = 1tCK
2. Dout n (or b) = data-out from column n (or column b).
3. DES commands are shown for ease of illustration; other commands may be valid at these times.
4. BL8 setting activated by MR0 A[1:0] = 01 and A12 = 1 during READ command at T0
BC4 setting activated by MR0 A[1:0] = 01 and A12 = 0 during READ command at T4.
5. CA Parity = Disable, CS to CA Latency = Disable, Read DBI = Disable

Figure 85 – READ (BL8) to READ (BC4) OTF with 1tCK Preamble in Different Bank Group

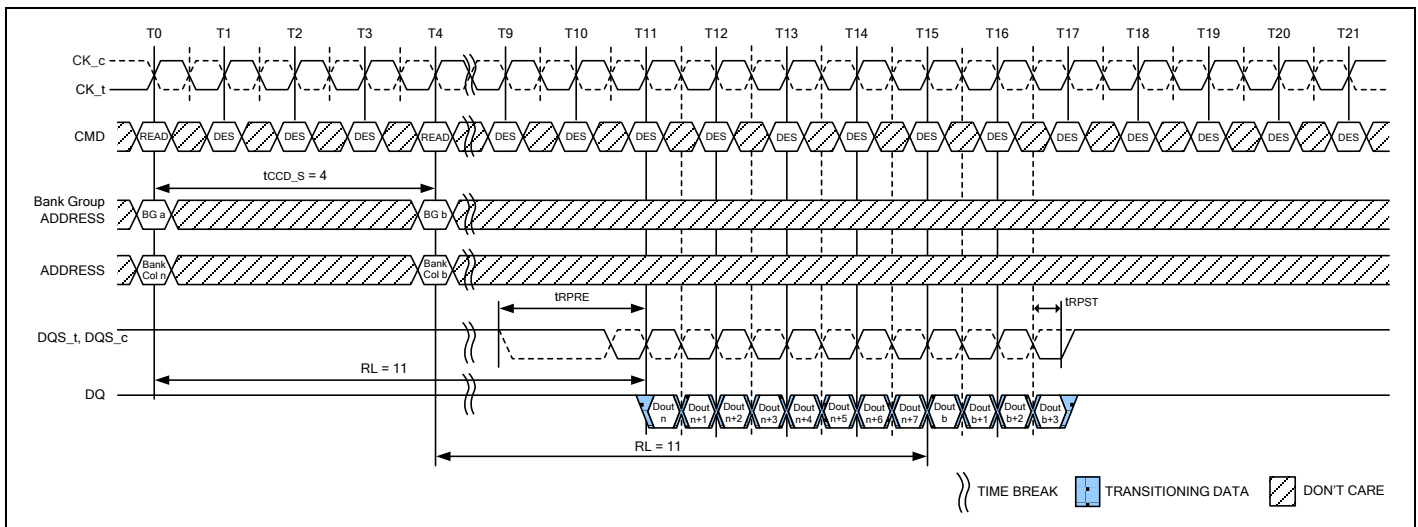

Notes:

1. BL = 8, AL = 0, CL = 11, Preamble = 2tCK
2. Dout n (or b) = data-out from column n (or column b).
3. DES commands are shown for ease of illustration; other commands may be valid at these times.
4. BL8 setting activated by MR0 A[1:0] = 01 and A12 = 1 during READ command at T0.
BC4 setting activated by MR0 A[1:0] = 01 and A12 = 0 during READ command at T4.
5. CA Parity = Disable, CS to CA Latency = Disable, Read DBI = Disable

Figure 86 – READ (BL8) to READ (BC4) OTF with 2tCK Preamble in Different Bank Group

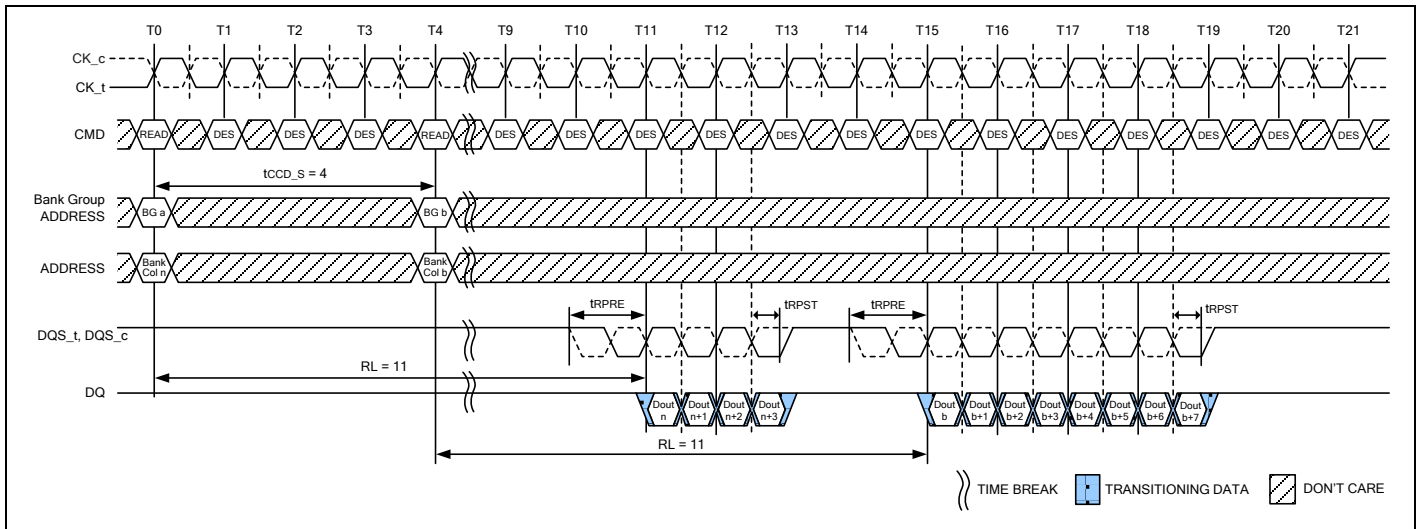

Notes:

1. BL = 8, AL = 0, CL = 11, Preamble = 1tCK
2. Dout n (or b) = data-out from column n (or column b).
3. DES commands are shown for ease of illustration; other commands may be valid at these times.
4. BC4 setting activated by MR0 A[1:0] = 01 and A12 = 0 during READ command at T0.
BL8 setting activated by MR0 A[1:0] = 01 and A12 = 1 during READ command at T4.
5. CA Parity = Disable, CS to CA Latency = Disable, Read DBI = Disable

Figure 87 – READ (BC4) to READ (BL8) OTF with 1tCK Preamble in Different Bank Group

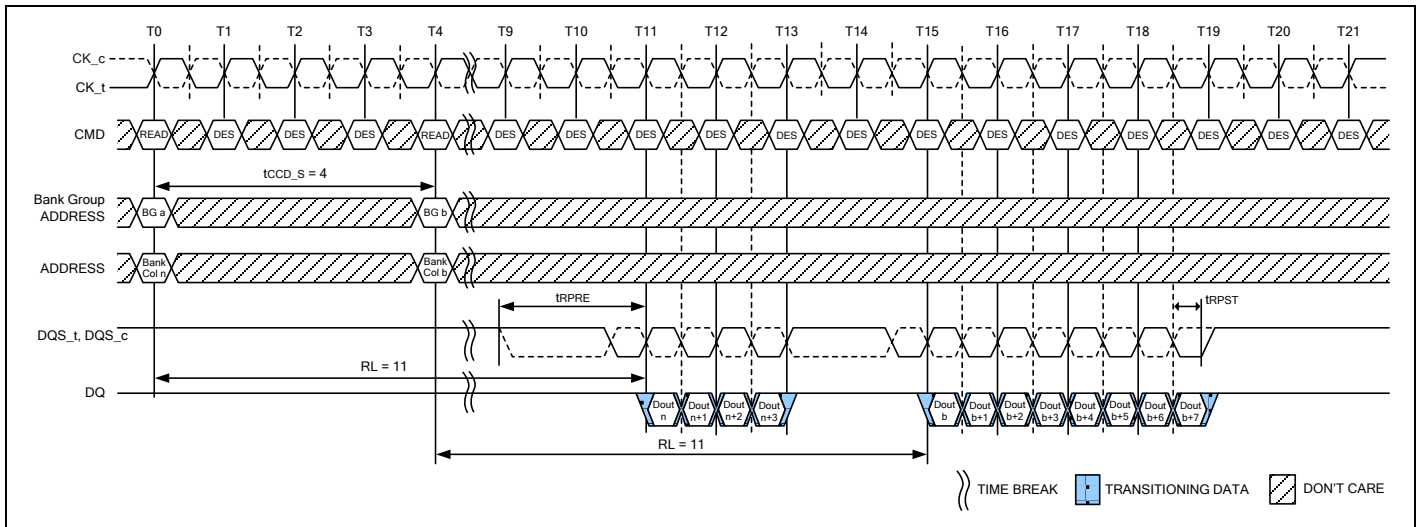

Notes:

1. BL = 8, AL = 0, CL = 11, Preamble = 2tCK
2. Dout n (or b) = data-out from column n (or column b).
3. DES commands are shown for ease of illustration; other commands may be valid at these times.
4. BC4 setting activated by MR0 A[1:0] = 01 and A12 = 0 during READ command at T0.
BL8 setting activated by MR0 A[1:0] = 01 and A12 = 1 during READ command at T4.
5. CA Parity = Disable, CS to CA Latency = Disable, Read DBI = Disable

Figure 88 – READ (BC4) to READ (BL8) OTF with 2tCK Preamble in Different Bank Group

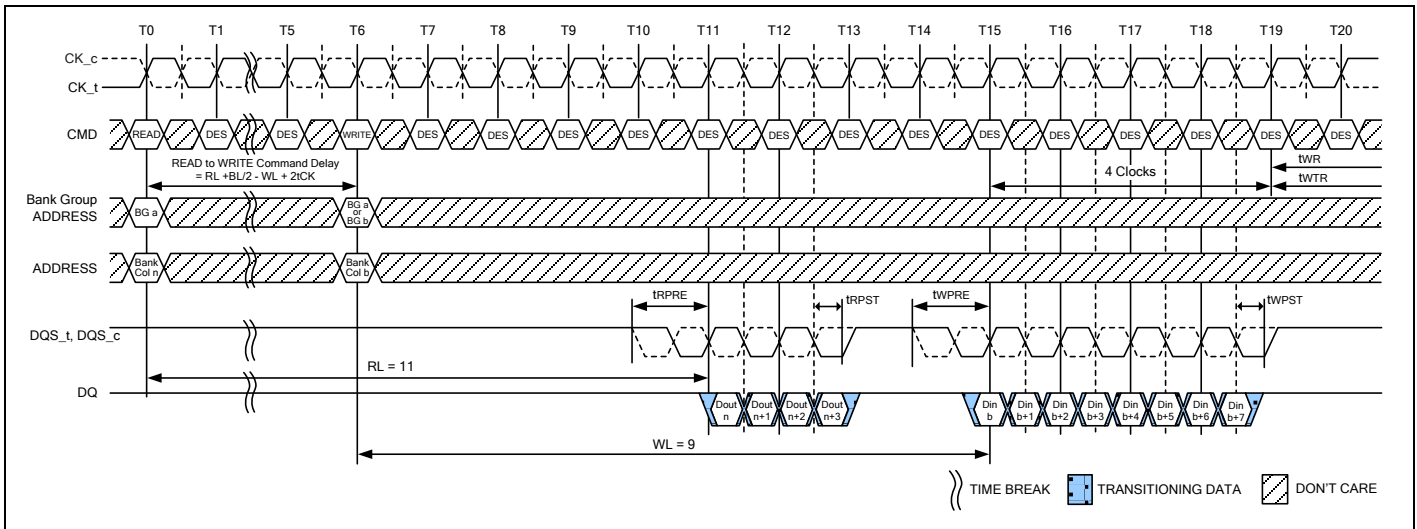

Notes:

1. BC = 4, RL = 11 (CL = 11, AL = 0), Read Preamble = 1tCK, WL=9 (CWL=9,AL=0), Write Preamble = 1tCK
2. Dout n = data-out from column n, Din b = data-in to column b.
3. DES commands are shown for ease of illustration; other commands may be valid at these times.
4. BC4 setting activated by MR0 A[1:0] = 01 and A12 = 0 during READ command at T0.
BL8 setting activated by MR0 A[1:0] = 01 and A12 = 1 during WRITE command at T6.
5. CA Parity = Disable, CS to CA Latency = Disable, Read DBI = Disable, Write DBI = Disable, Write CRC = Disable

Figure 89 – READ (BC4) to WRITE (BL8) OTF with 1tCK Preamble in Same or Different Bank Group

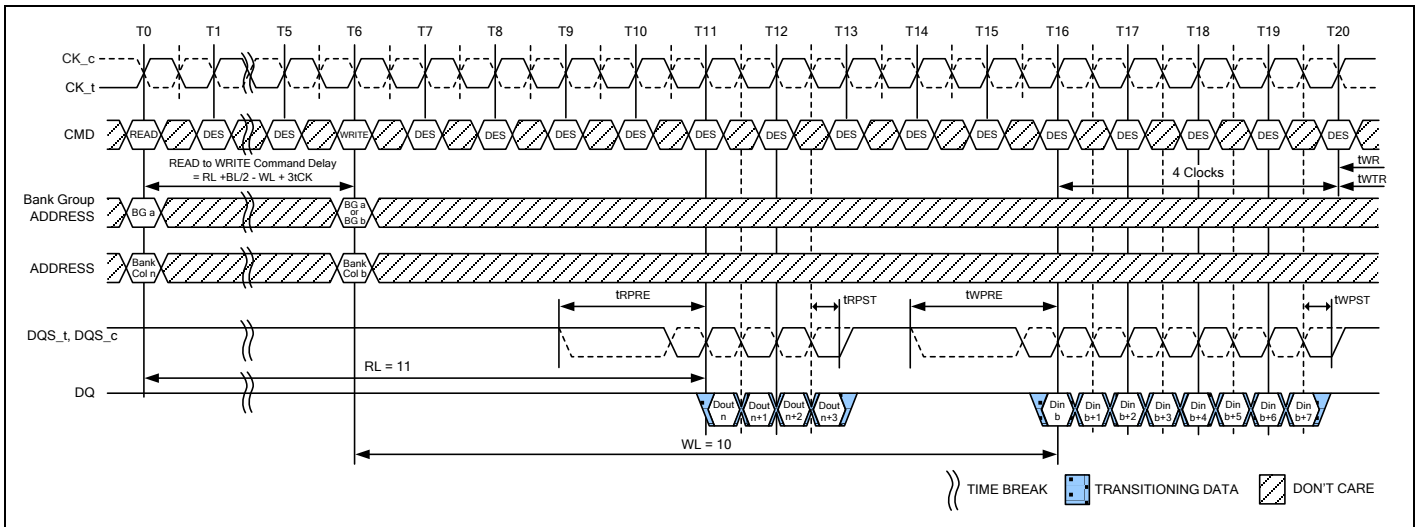

Notes:

1. BC = 4, RL = 11 (CL = 11, AL = 0), Read Preamble = 2tCK, WL = 10 (CWL = 9+1⁵, AL = 0), Write Preamble = 2tCK
2. Dout n = data-out from column n, Din b = data-in to column b.
3. DES commands are shown for ease of illustration; other commands may be valid at these times.
4. BC4 setting activated by MR0 A[1:0] = 01 and A12 = 0 during READ command at T0.
BL8 setting activated by MR0 A[1:0] = 01 and A12 = 1 during WRITE command at T6.
5. When operating in 2tCK Write Preamble Mode, CWL must be programmed to a value at least 1 clock greater than the lowest CWL setting.
6. CA Parity = Disable, CS to CA Latency = Disable, Read DBI = Disable, Write DBI = Disable, Write CRC = Disable

Figure 90 – READ (BC4) to WRITE (BL8) OTF with 2tCK Preamble in Same or Different Bank Group

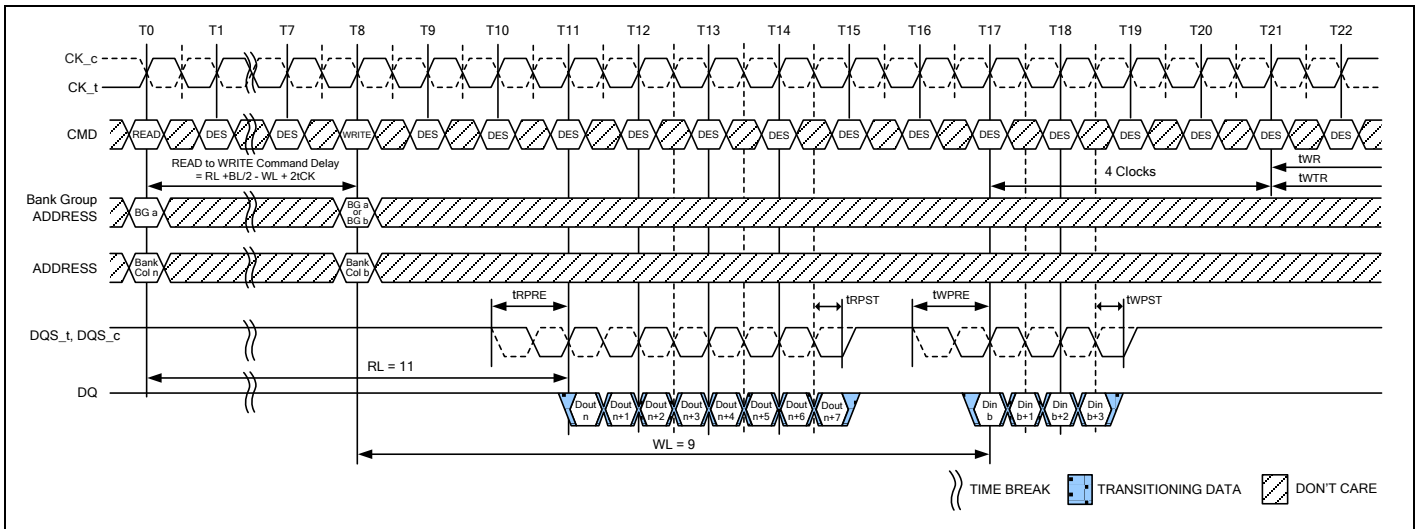

Notes:

1. BL = 8, RL = 11 (CL = 11, AL = 0), Read Preamble = 1tCK, WL=9(CWL=9, AL=0), Write Preamble = 1tCK
2. Dout n = data-out from column n, Din b = data-in to column b.
3. DES commands are shown for ease of illustration; other commands may be valid at these times.
4. BL8 setting activated by MR0 A[1:0] = 01 and A12 = 1 during READ command at T0.
BC4 setting activated by MR0 A[1:0] = 01 and A12 = 0 during WRITE command at T8.
5. CA Parity = Disable, CS to CA Latency = Disable, Read DBI = Disable, Write DBI = Disable, Write CRC = Disable

Figure 91 – READ (BL8) to WRITE (BC4) OTF with 1tCK Preamble in Same or Different Bank Group

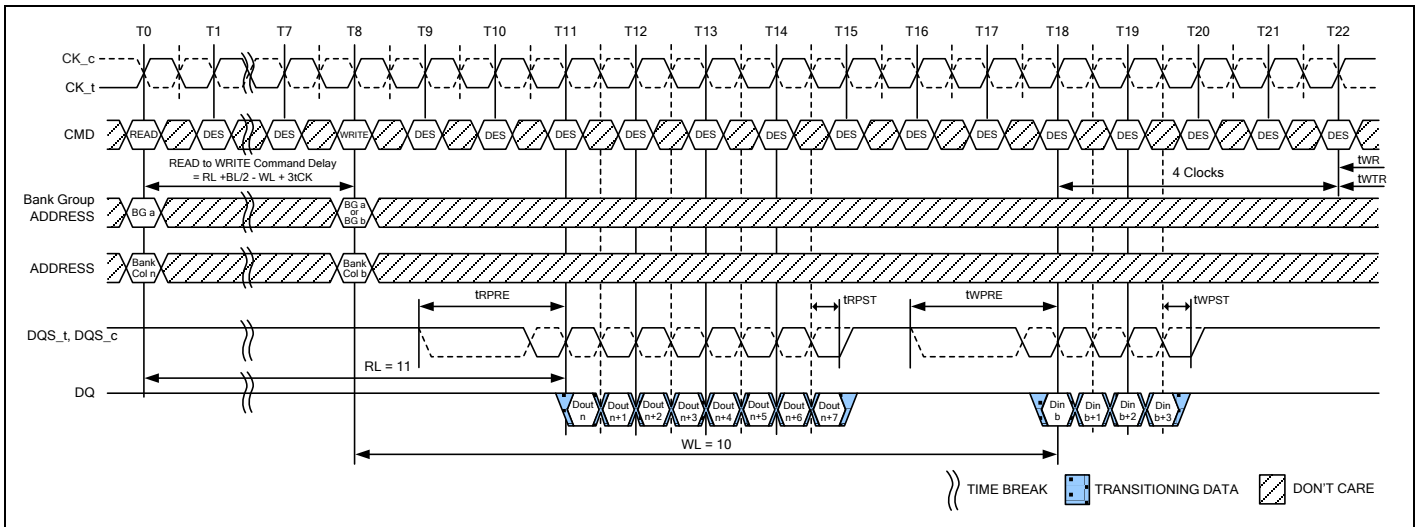

Notes:

1. BL = 8, RL = 11 (CL = 11, AL = 0), Read Preamble = 2tCK, WL = 10 (CWL = 9+1⁵, AL = 0), Write Preamble = 2tCK
2. Dout n = data-out from column n, Din b = data-in to column b.
3. DES commands are shown for ease of illustration; other commands may be valid at these times.
4. BL8 setting activated by MR0 A[1:0] = 01 and A12 = 1 during READ command at T0.
BC4 setting activated by MR0 A[1:0] = 01 and A12 = 0 during WRITE command at T8.
5. When operating in 2tCK Write Preamble Mode, CWL must be programmed to a value at least 1 clock greater than the lowest CWL setting.
6. CA Parity = Disable, CS to CA Latency = Disable, Read DBI = Disable, Write DBI = Disable, Write CRC = Disable

Figure 92 – READ (BL8) to WRITE (BC4) OTF with 2tCK Preamble in Same or Different Bank Group



9.26.3 Burst Read Operation Followed by a Precharge

The minimum external Read command to Precharge command spacing to the same bank is equal to $AL + tRTP$ with $tRTP$ being the Internal Read Command to Precharge Command Delay. Note that the minimum ACT to PRE timing, $tRAS$, must be satisfied as well. The minimum value for the Internal Read Command to Precharge Command Delay is given by $tRTP_{min}$. A new bank active command may be issued to the same bank if the following two conditions are satisfied simultaneously:

1. The minimum RAS precharge time (tRP_{min}) has been satisfied from the clock at which the precharge begins.
2. The minimum RAS cycle time (tRC_{min}) from the previous bank activation has been satisfied.

Examples of Read commands followed by Precharge are show in Figure 93 to Figure 95 and READ with Auto Precharge are show in Figure 96 to Figure 97.

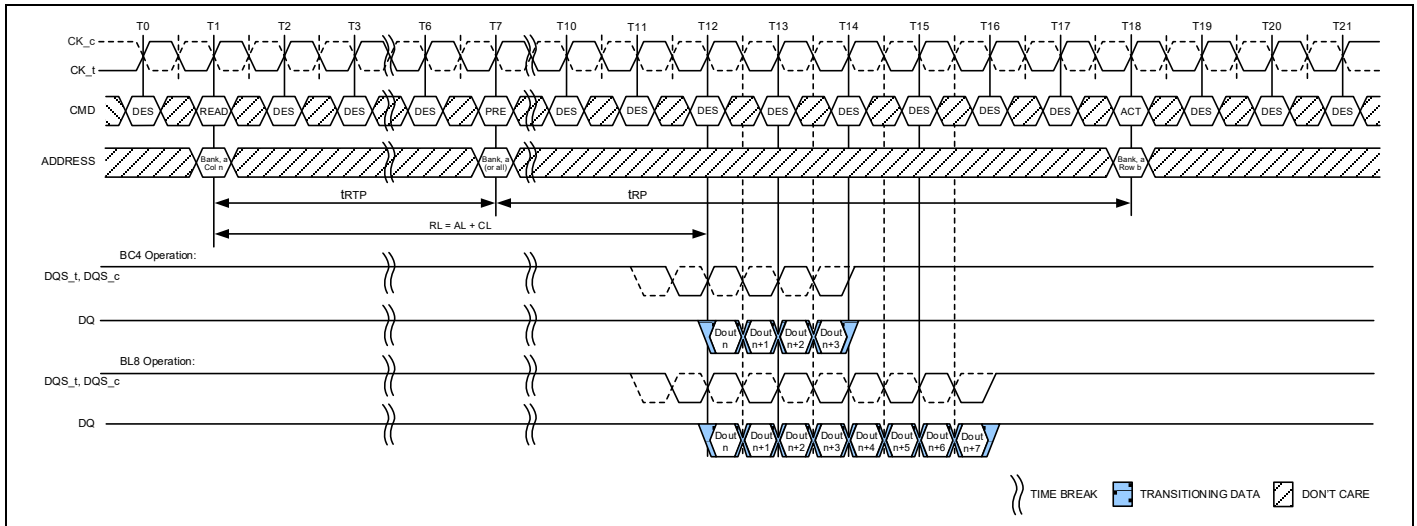

Notes:

1. BL = 8, RL = 11(CL = 11, AL = 0), Preamble = 1tCK, $tRTP = 6$, $tRP = 11$
2. Dout n = data-out from column n.
3. DES commands are shown for ease of illustration; other commands may be valid at these times.
4. The example assumes $tRAS_{min}$ is satisfied at Precharge command time (T7) and that tRC_{min} is satisfied at the next Active command time (T18).
5. CA Parity = Disable, CS to CA Latency = Disable, Read DBI = Disable

Figure 93 – READ to PRECHARGE with 1tCK Preamble

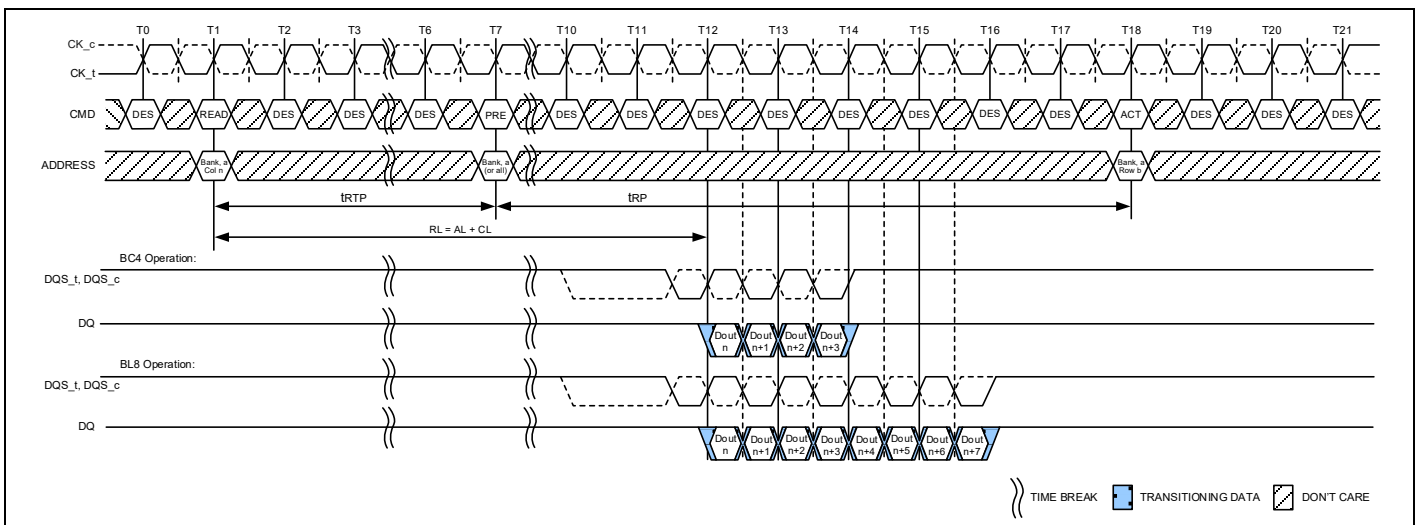

Notes:

1. BL = 8, RL = 11(CL = 11, AL = 0), Preamble = 2tCK, $tRTP = 6$, $tRP = 11$
2. Dout n = data-out from column n.
3. DES commands are shown for ease of illustration; other commands may be valid at these times.
4. The example assumes $tRAS_{min}$ is satisfied at Precharge command time (T7) and that tRC_{min} is satisfied at the next Active command time (T18).
5. CA Parity = Disable, CS to CA Latency = Disable, Read DBI = Disable

Figure 94 – READ to PRECHARGE with 2tCK Preamble

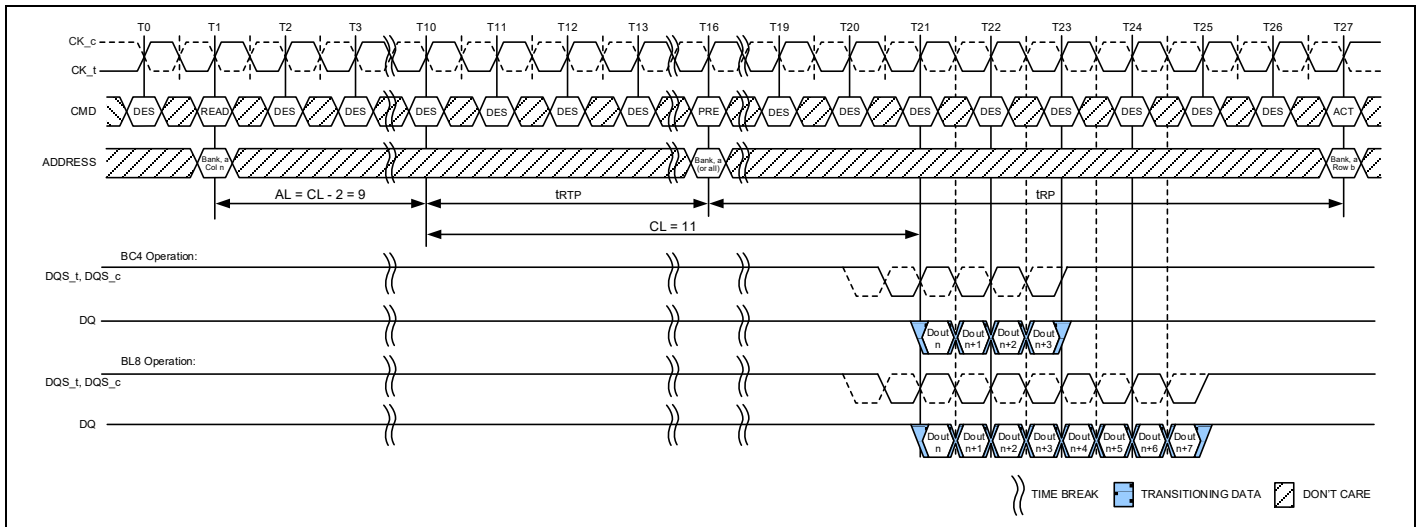

Notes:

1. BL = 8, RL = 20 (CL = 11, AL = CL - 2), Preamble = 1tCK, tRTP = 6, tRP = 11
2. Dout n = data-out from column n.
3. DES commands are shown for ease of illustration; other commands may be valid at these times.
4. The example assumes tRAS min is satisfied at Precharge command time (T16) and that tRC min is satisfied at the next Active command time (T27).
5. CA Parity = Disable, CS to CA Latency = Disable, Read DBI = Disable

Figure 95 – READ to PRECHARGE with Additive Latency and 1tCK Preamble

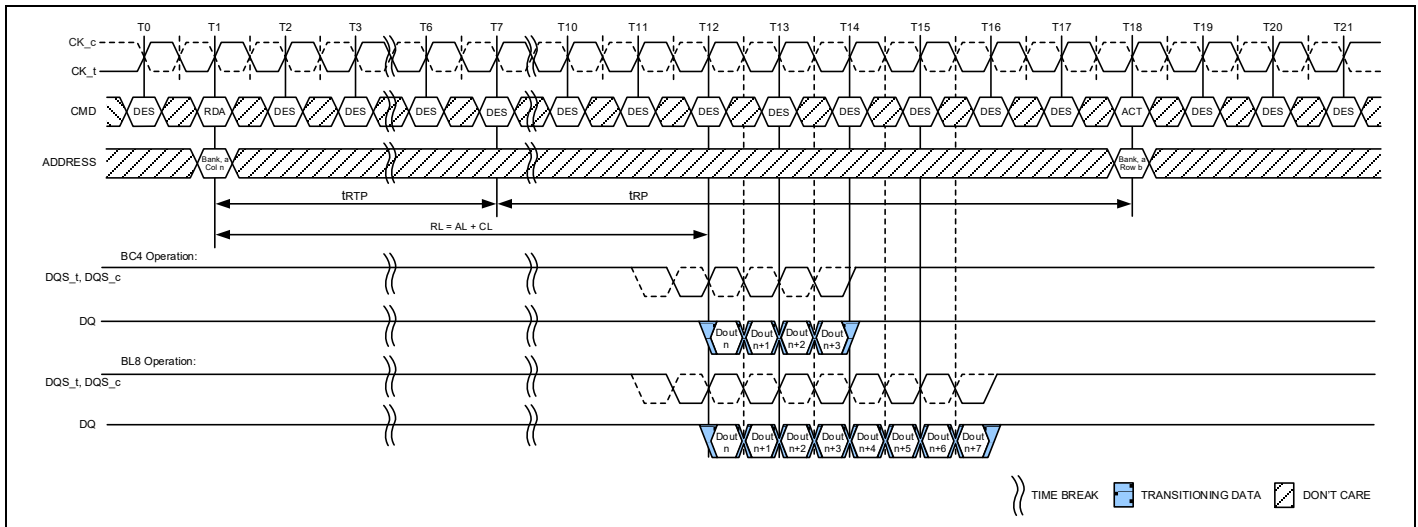

Notes:

1. BL = 8, RL = 11 (CL = 11, AL = 0), Preamble = 1tCK, tRTP = 6, tRP = 11
2. Dout n = data-out from column n.
3. DES commands are shown for ease of illustration; other commands may be valid at these times.
4. tRTP = 6 setting activated by MR0 A[11:9] = 001
5. The example assumes tRC min is satisfied at the next Active command time (T18).
6. /CA Parity = Disable, CS to CA Latency = Disable, Read DBI = Disable

Figure 96 – READ with Auto Precharge and 1tCK Preamble

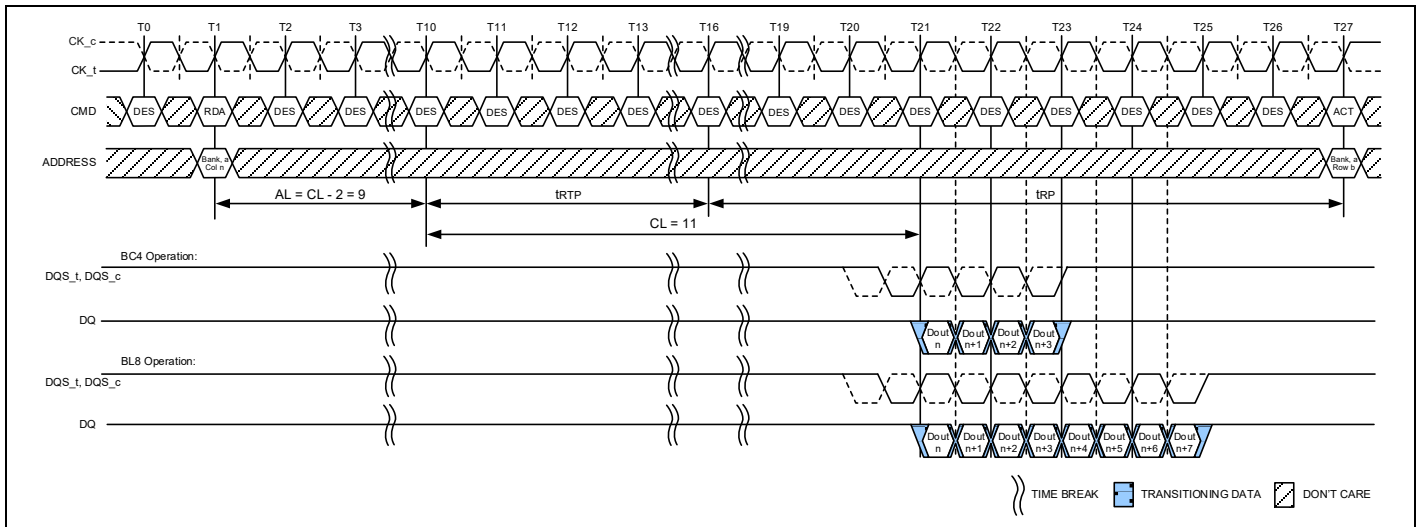

Notes:

1. BL = 8, RL = 20 (CL = 11, AL = CL - 2), Preamble = 1tCK, tRTP = 6, TRP = 11
2. Dout n = data-out from column n.
3. DES commands are shown for ease of illustration; other commands may be valid at these times.
4. tRTP = 6 setting activated by MR0 A[11:9] = 001
5. The example assumes tRC min is satisfied at the next Active command time (T27).
6. CA Parity = Disable, CS to CA Latency = Disable, Read DBI = Disable

Figure 97 – READ with Auto Precharge, Additive Latency and 1tCK Preamble

9.26.4 Burst Read Operation with Read DBI (Data Bus Inversion)

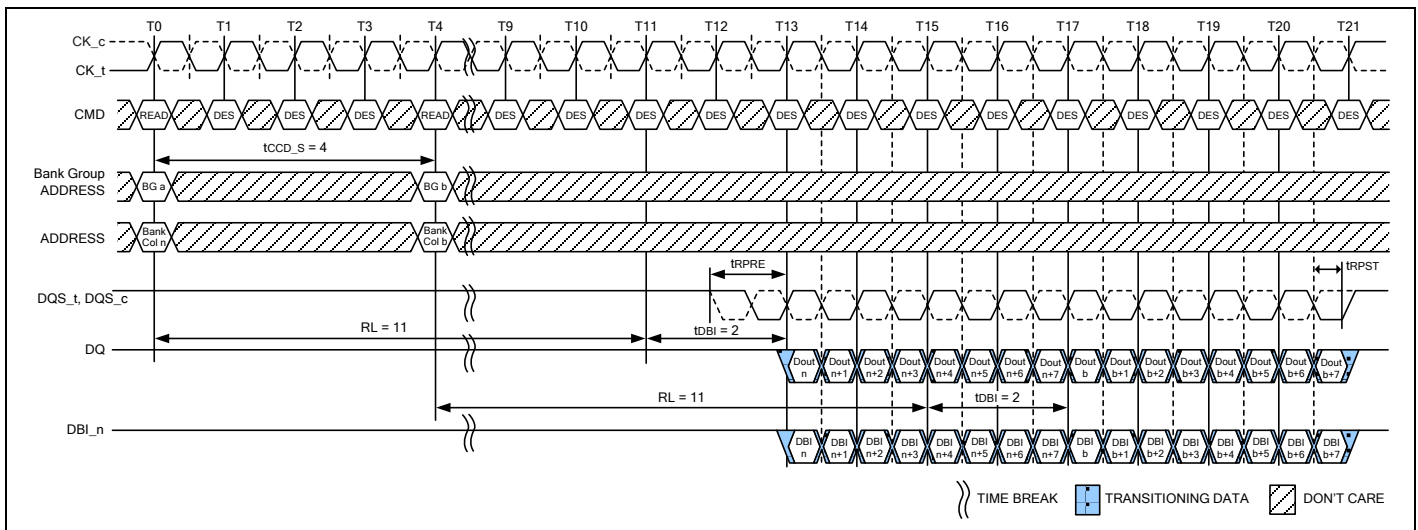

Notes:

1. BL = 8, AL = 0, CL = 11, Preamble = 1tCK, tDBI = 2tCK
2. Dout n (or b) = data-out from column n (or column b); DBI n (or b) = data businversion from column n (or column b).
3. DES commands are shown for ease of illustration; other commands may be valid at these times.
4. BL8 setting activated by either MR0 A[1:0] = 00 or MR0 A[1:0] = 01 and A12 = 1 during READ command at T0 and T4.
5. CA Parity = Disable, CS to CA Latency = Disable, Read DBI = Enable.

Figure 98 – Consecutive READ (BL8) with 1tCK Preamble and DBI in Different Bank Group



9.2.6.5 Burst Read Operation with Command/Address Parity

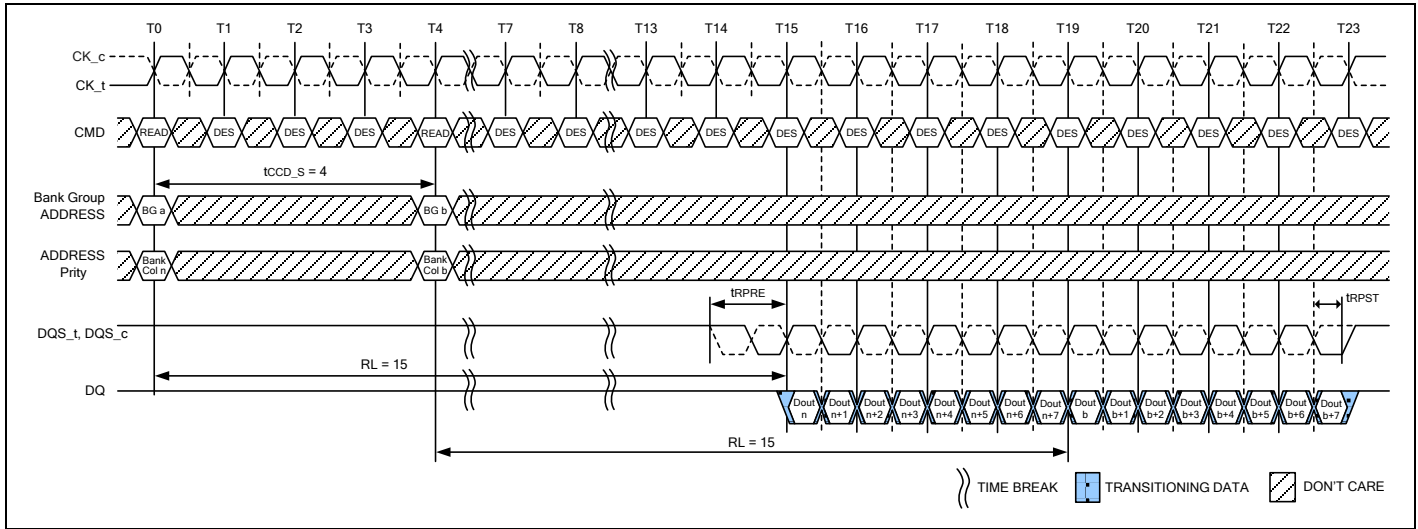

Notes:

1. BL = 8, AL = 0, CL = 11, PL = 4, (RL = CL + AL + PL = 15), Preamble = 1tCK
2. Dout n (or b) = data-out from column n (or column b).
3. DES commands are shown for ease of illustration; other commands may be valid at these times.
4. BL8 setting activated by either MR0 A[1:0] = 00 or MR0 A[1:0] = 01 and A12 = 1 during READ command at T0 and T4.
5. CA Parity = Enable, CS to CA Latency = Disable, Read DBI = Disable

Figure 99 – Consecutive READ (BL8) with 1tCK Preamble and CA Parity in Different Bank Group

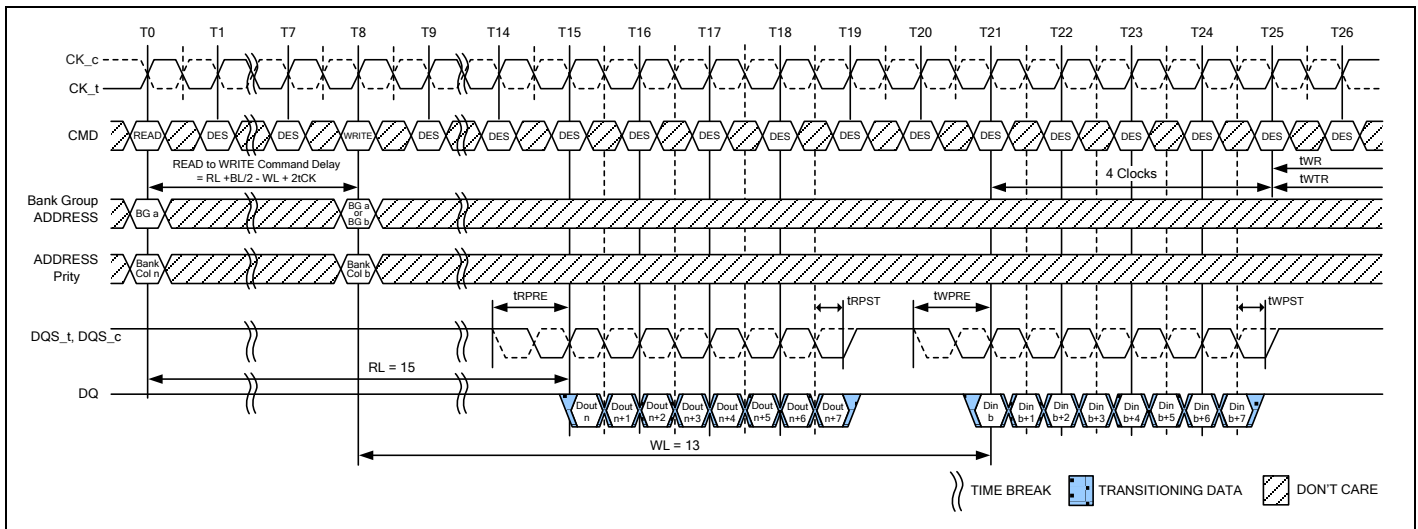

Notes:

1. BL = 8, AL = 0, CL = 11, PL = 4, (RL = CL + AL + PL = 15), Read Preamble = 1tCK; CWL = 9, AL = 0, PL = 4, (WL = CL + AL + PL = 13), Write Preamble = 1tCK
2. Dout n = data-out from column n, Din b = data-in to column b.
3. DES commands are shown for ease of illustration; other commands may be valid at these times.
4. BL8 setting activated by either MR0 A[1:0] = 00 or MR0 A[1:0] = 01 and A12 = 1 during READ command at T0 and Write command at T8.
5. CA Parity = Enable, CS to CA Latency = Disable, Read DBI = Disable, Write DBI = Disable, Write CRC = Disable

Figure 100 – READ (BL8) to WRITE (BL8) with 1tCK Preamble and CA parity in Same or Different Bank Group



9.2.6 Read to Write with Write CRC

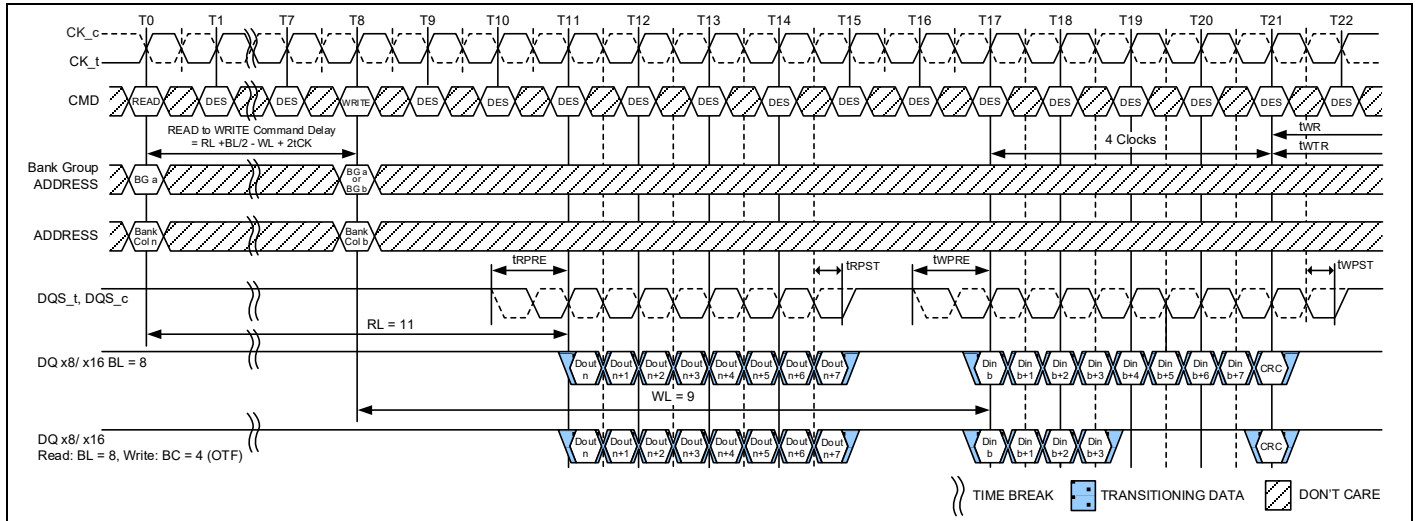

Notes:

1. BL = 8 (or BC = 4: OTF for Write), RL = 11 (CL = 11, AL = 0), Read Preamble = 1tCK, WL = 9 (CWL = 9, AL = 0), Write Preamble = 1tCK
2. Dout n = data-out from column n. Din b = data-in to column b.
3. DES commands are shown for ease of illustration; other commands may be valid at these times.
4. BL8 setting activated by either MR0 A[1:0] = 00 or MR0 A[1:0] = 01 and A12 = 1 during READ command at T0 and Write command at T8.
5. BC4 setting activated by MR0 A[1:0] = 01 and A12 = 0 during Write command at T8.
6. CA Parity = Disable, CS to CA Latency = Disable, Read DBI = Disable, Write DBI = Disable, Write CRC = Enable

Figure 101 – READ (BL8) to WRITE (BL8 or BC4: OTF) with 1tCK Preamble and Write CRC in Same or Different Bank Group

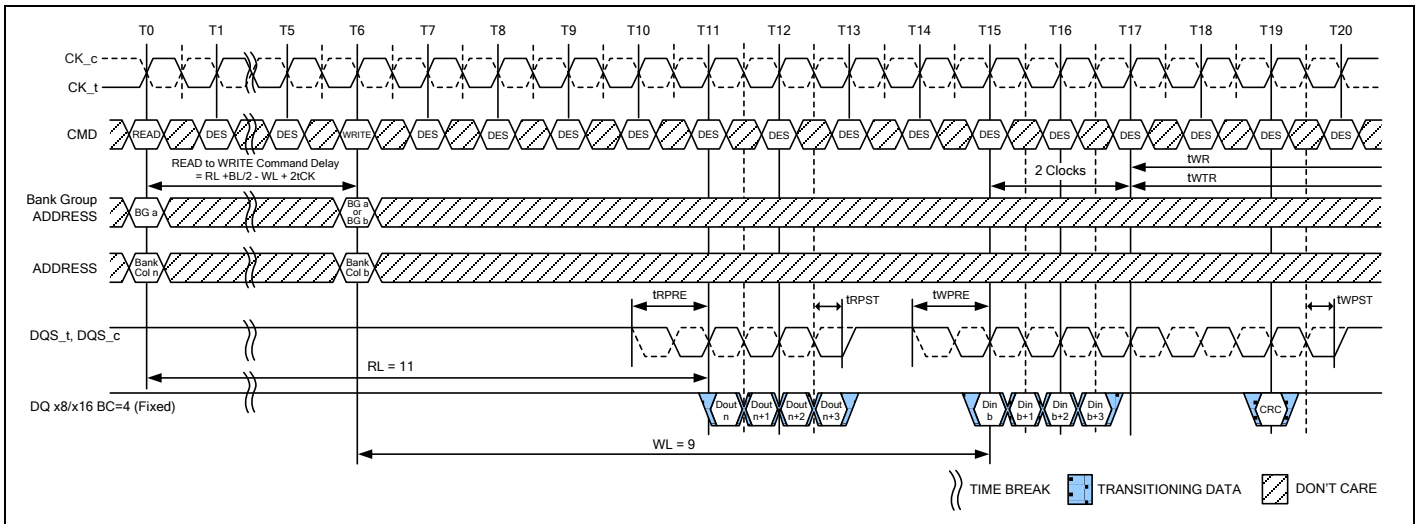

Notes:

1. BC = 4 (Fixed), RL = 11 (CL = 11, AL = 0), Read Preamble = 1tCK, WL = 9 (CWL = 9, AL = 0), Write Preamble = 1tCK
2. Dout n = data-out from column n. Din b = data-in to column b.
3. DES commands are shown for ease of illustration; other commands may be valid at these times.
4. BC4 setting activated by MR0 A[1:0] = 10.
5. CA Parity = Disable, CS to CA Latency = Disable, Read DBI = Disable, Write DBI = Disable, Write CRC = Enable

Figure 102 – READ (BC4: Fixed) to WRITE (BC4: Fixed) with 1tCK Preamble and Write CRC in Same or Different Bank Group



9.2.6.7 Read to Read with CS to CA Latency

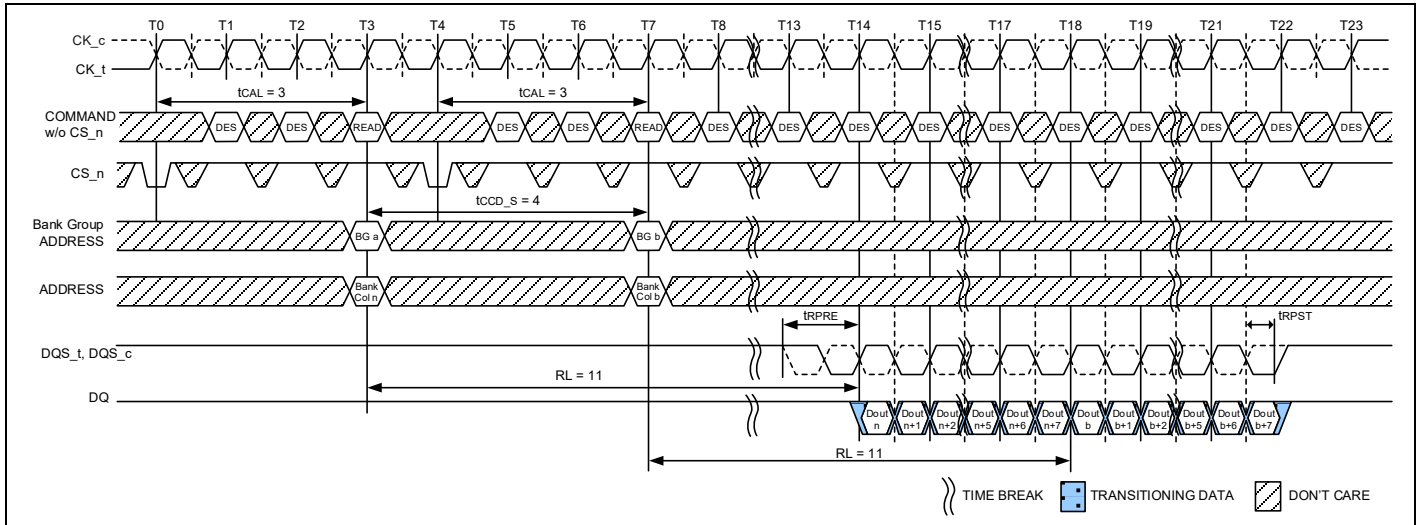

Notes:

1. BL = 8, AL = 0, CL = 11, CAL = 3, Preamble = 1tCK
2. Dout n (or b) = data-out from column n (or column b).
3. DES commands are shown for ease of illustration; other commands may be valid at these times.
4. BL8 setting activated by either MR0 A[1:0] = 00 or MR0 A[1:0] = 01 and A12 = 1 during READ command at T3 and T7.
5. CA Parity = Disable, CS to CA Latency = Enable, Read DBI = Disable
6. Enabling of CAL mode does not impact ODT control timings. Users should maintain the same timing relationship relative to the command/address bus as when CAL is disabled.

Figure 103 – Consecutive READ (BL8) with CAL(3) and 1tCK Preamble in Different Bank Group

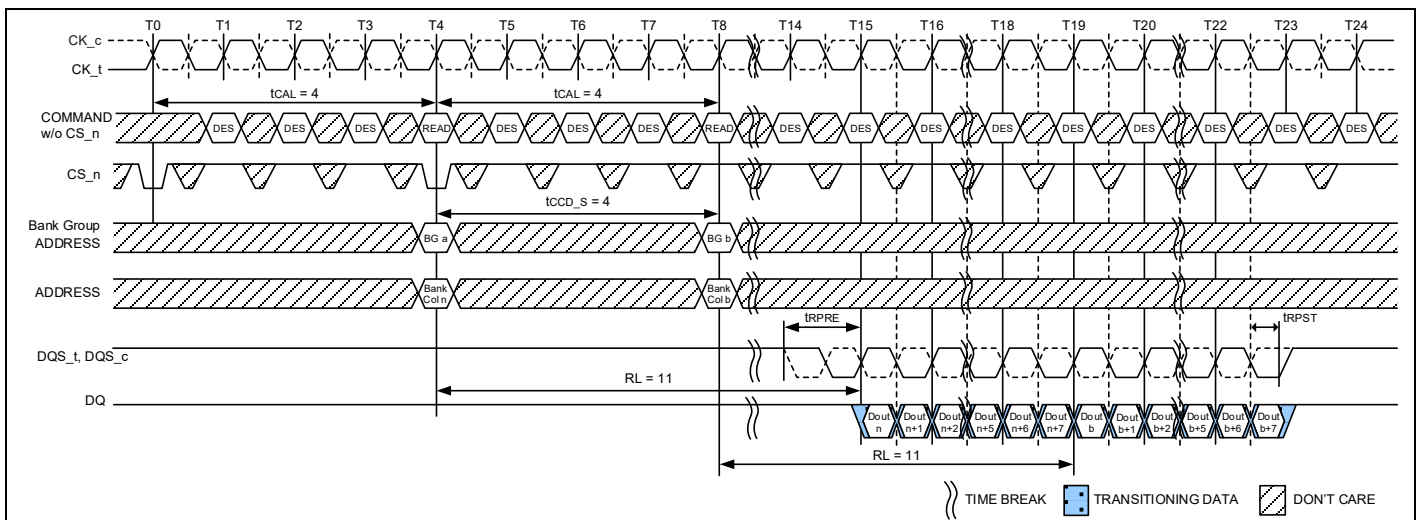

Notes:

1. BL = 8, AL = 0, CL = 11, CAL = 4, Preamble = 1tCK
2. Dout n (or b) = data-out from column n (or column b).
3. DES commands are shown for ease of illustration; other commands may be valid at these times.
4. BL8 setting activated by either MR0 A[1:0] = 00 or MR0 A[1:0] = 01 and A12 = 1 during READ command at T4 and T8.
5. CA Parity = Disable, CS to CA Latency = Enable, Read DBI = Disable
6. Enabling of CAL mode does not impact ODT control timings. Users should maintain the same timing relationship relative to the command/address bus as when CAL is disabled.

Figure 104 – Consecutive READ (BL8) with CAL(4) and 1tCK Preamble in Different Bank Group



9.27.3 tWPRE Calculation

The method for calculating differential pulse widths for tWPRE is shown in Figure 107.

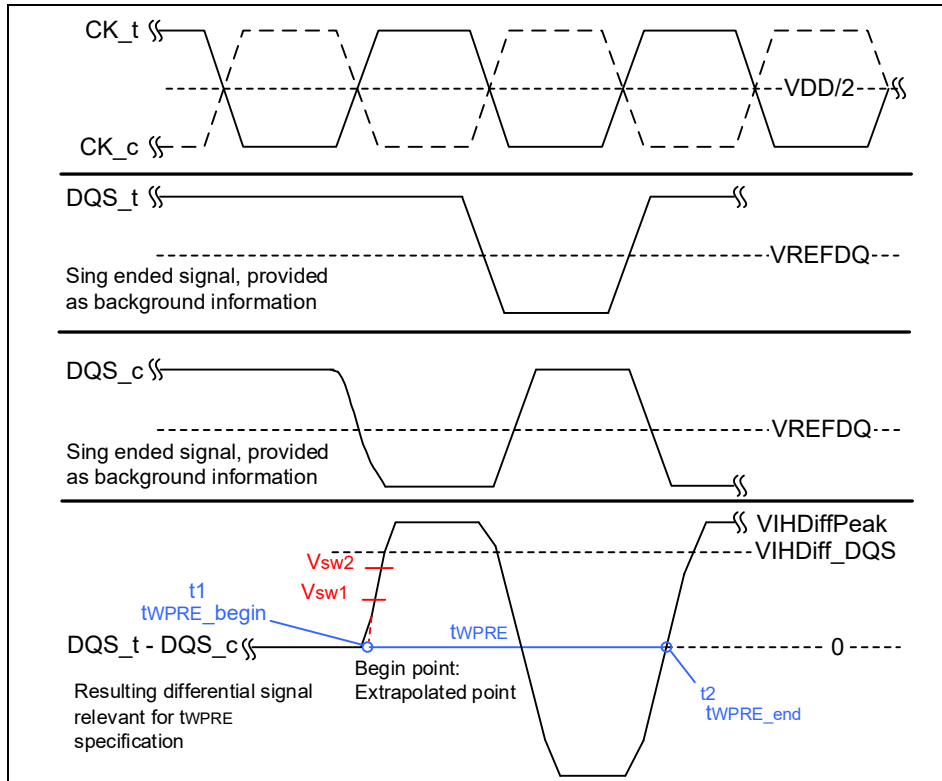

Figure 107 – Method for calculating tWPRE transitions and endpoints

Table 44 – Reference Voltage for tWPRE Timing Measurements

Measured Parameter	Measured Parameter Symbol	Vsw1[V]	Vsw2[V]	Note
DQS_t, DQS_c differential WRITE Preamble	tWPRE	VIHDiff_DQS x 0.1	VIHDiff_DQS x 0.9	

The method for calculating differential pulse widths for tWPRE2 is same as tWPRE.



9.27.4 tWPST Calculation

The method for calculating differential pulse widths for tWPST is shown in Figure 108.

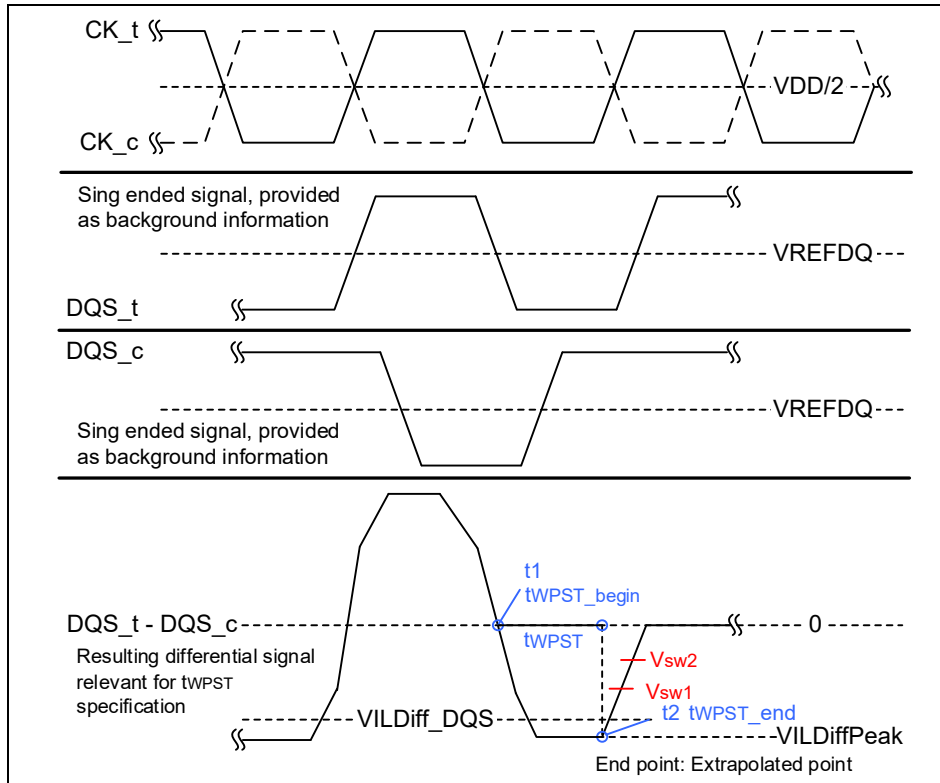

Figure 108 – Method for calculating tWPST transitions and endpoints

Table 45 – Reference Voltage for tWPST Timing Measurements

Measured Parameter	Measured Parameter Symbol	Vsw1[V]	Vsw2[V]	Note
DQS_t, DQS_c differential WRITE Postamble	tWPST	VILDiff_DQS x 0.9	VILDiff_DQS x 0.1	

Table 46 – Timing Parameters by Speed Grade

Parameter	Symbol	DDR4-1600,1866,2133		DDR4-2400,2666,3200		Note
		Min	Max	Min	Max	
DQS_t, DQS_c differential WRITE Preamble (1tCK Preamble)	tWPRE	0.9	-	0.9	-	tCK(avg)
DQS_t, DQS_c differential WRITE Preamble (2tCK Preamble)	tWPRE2	NA	-	1.8	-	tCK(avg)
DQS_t, DQS_c differential WRITE Postamble	tWPST	0.33	-	0.33	-	tCK(avg)
DQS_t, DQS_c differential input low pulse width	tDQSL	0.46	0.54	0.46	0.54	tCK(avg)
DQS_t, DQS_c differential input high pulse width	tDQSH	0.46	0.54	0.46	0.54	tCK(avg)
DQS_t, DQS_c differential input high pulse width at 2tCK Preamble	tDQSH2PRE	-	-	-	-	tCK(avg)
DQS_t, DQS_c rising edge to CK_t, CK_c rising edge (1tCK Preamble)	tDQSS	-0.27	0.27	-0.27	0.27	tCK(avg)
DQS_t, DQS_c falling edge setup time to CK_t, CK_c rising edge	tDSS	0.18	-	0.18	-	tCK(avg)
DQS_t, DQS_c falling edge hold time from CK_t, CK_c rising edge	tDSH	0.18	-	0.18	-	tCK(avg)



9.2.7.5 Write Burst Operation

The following write timing diagram is to help understanding of each write parameter's meaning and just examples. The details of the definition of each parameter will be defined separately.

In these write timing diagram, CK and DQS are shown aligned and also DQS and DQ are shown center aligned for illustration purpose.

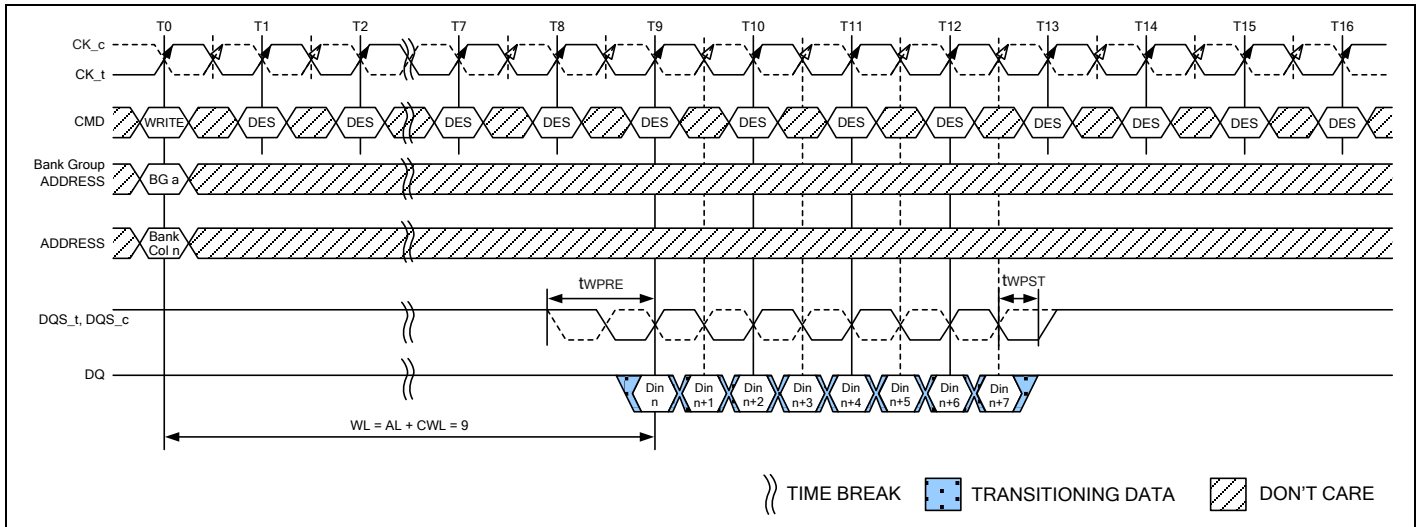

Notes:

1. BL = 8, WL = 9, AL = 0, CWL = 9, Preamble = 1tCK
2. Din n = data-in to column n.
3. DES commands are shown for ease of illustration; other commands may be valid at these times.
4. BL8 setting activated by either MR0 A[1:0] = 00 or MR0 A[1:0] = 01 and A12 = 1 during WRITE command at T0.
5. CA Parity = Disable, CS to CA Latency = Disable, Write DBI = Disable

Figure 109 – WRITE Burst Operation WL = 9 (AL = 0, CWL = 9, BL8)

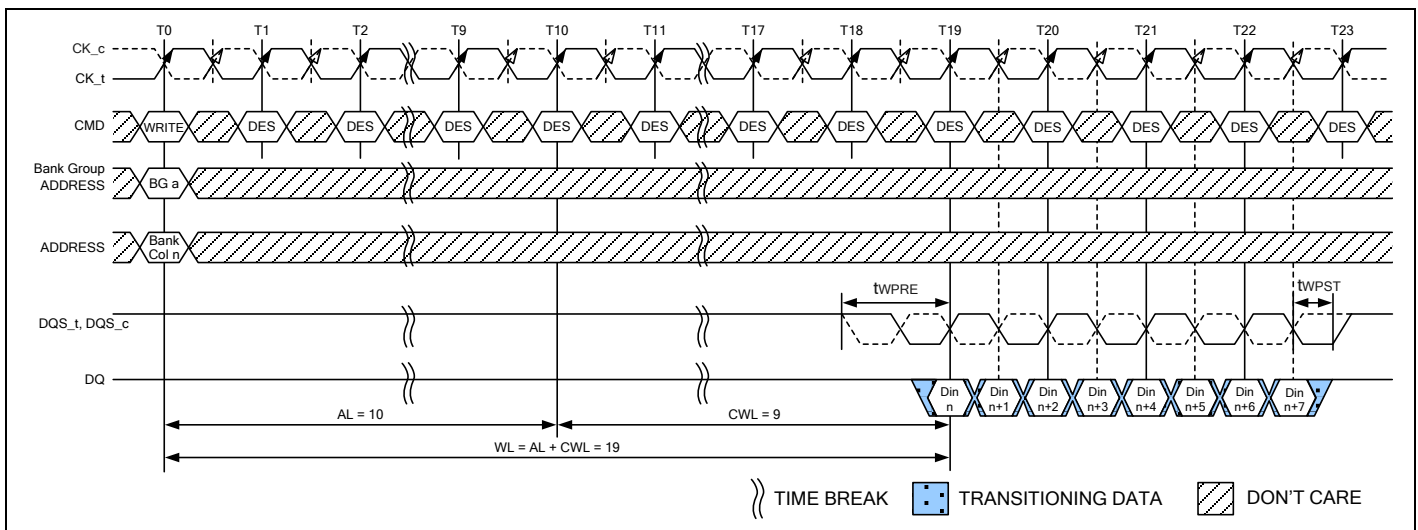

Notes:

1. BL = 8, WL = 19, AL = 10 (CL-1), CWL = 9, Preamble = 1tCK
2. Din n = data-in to column n.
3. DES commands are shown for ease of illustration; other commands may be valid at these times.
4. BL8 setting activated by either MR0 A[1:0] = 00 or MR0 A[1:0] = 01 and A12 = 1 during WRITE command at T0.
5. CA Parity = Disable, CS to CA Latency = Disable, Write DBI = Disable

Figure 110 – WRITE Burst Operation WL = 19 (AL = 10, CWL = 9, BL8)

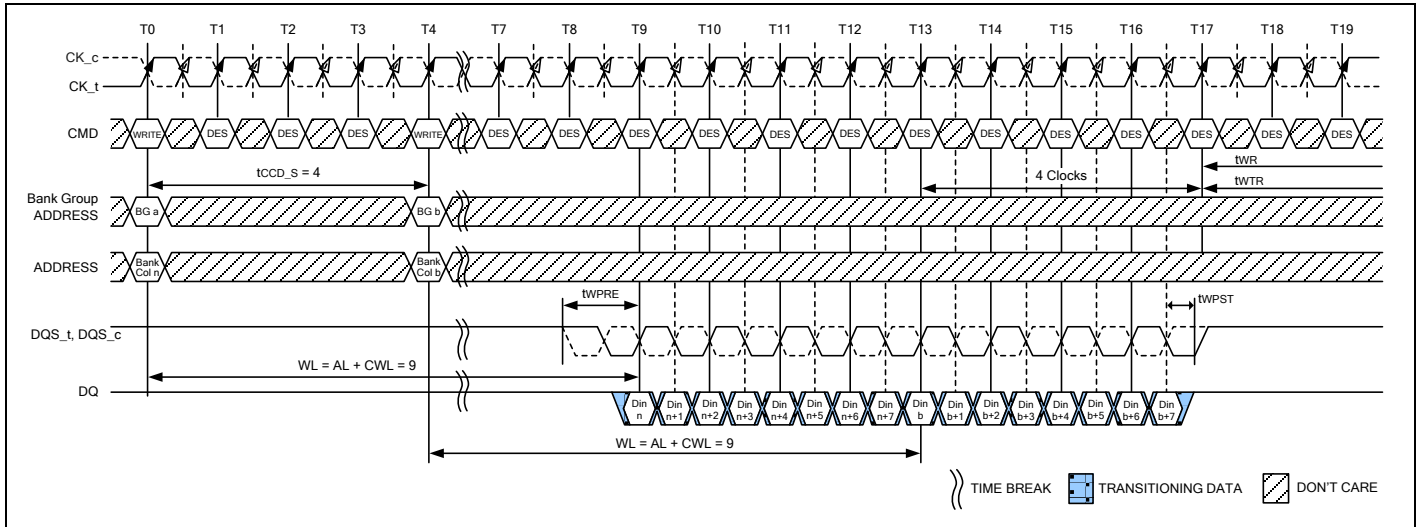

Notes:

1. BL = 8, AL = 0, CWL = 9, Preamble = 1tCK
2. Din n (or b) = data-in to column n (or column b).
3. DES commands are shown for ease of illustration; other commands may be valid at these times.
4. BL8 setting activated by either MR0 A[1:0] = 00 or MR0 A[1:0] = 01 and A12 = 1 during WRITE command at T0 and T4.
5. C/A Parity = Disable, CS to CA Latency = Disable, Write DBI = Disable
6. The write recovery time (tWR) and write timing parameter (tWTR) are referenced from the first rising clock edge after the last write data shown at T17.

Figure 111 – Consecutive WRITE (BL8) with 1tCK Preamble in Different Bank Group

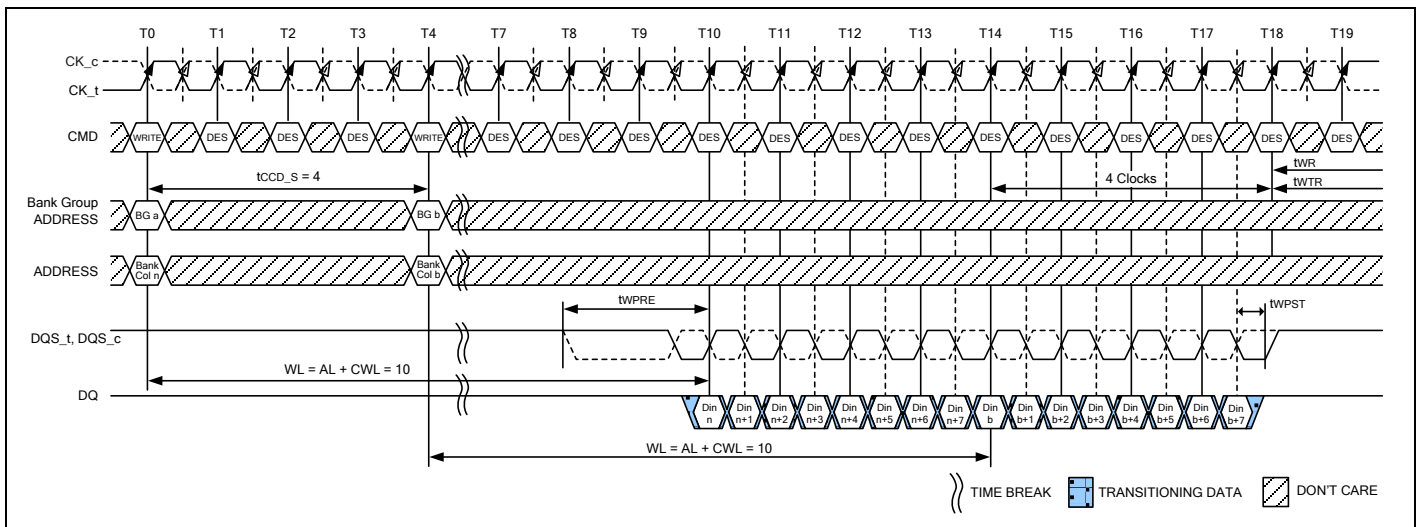

Notes:

1. BL = 8, AL = 0, CWL = 9 + 1 = 10^{*7}, Preamble = 2tCK
2. Din n (or b) = data-in to column n (or column b).
3. DES commands are shown for ease of illustration; other commands may be valid at these times.
4. BL8 setting activated by either MR0 A[1:0] = 00 or MR0 A[1:0] = 01 and A12 = 1 during WRITE command at T0 and T4.
5. CA Parity = Disable, CS to CA Latency = Disable, Write DBI = Disable
6. The write recovery time (tWR) and write timing parameter (tWTR) are referenced from the first rising clock edge after the last write data shown at T18.
7. When operating in 2tCK Write Preamble Mode, CWL must be programmed to a value at least 1 clock greater than the lowest CWL setting supported in the applicable tCK range. That means CWL = 9 isn't allowed when operating in 2tCK Write Preamble Mode.

Figure 112 – Consecutive WRITE (BL8) with 2tCK Preamble in Different Bank Group

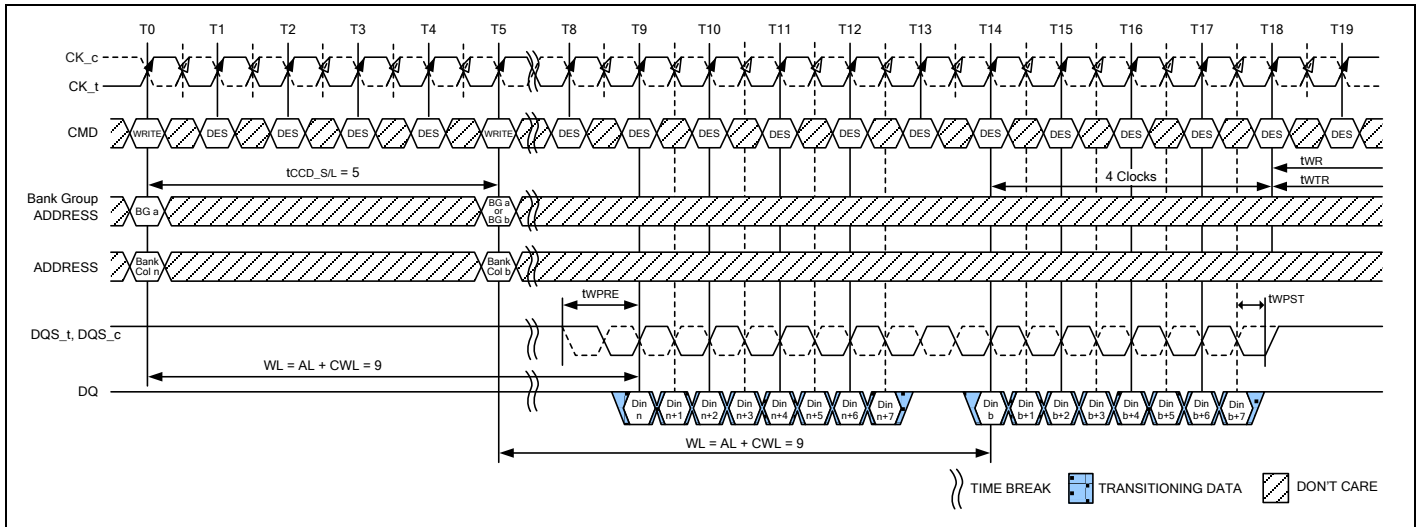

Notes:

1. BL = 8, AL = 0, CWL = 9, Preamble = 1tCK, tCCD_S/L = 5
2. Din n (or b) = data-in to column n (or column b).
3. DES commands are shown for ease of illustration; other commands may be valid at these times.
4. BL8 setting activated by either MR0 A[1:0] = 00 or MR0 A[1:0] = 01 and A12 = 1 during WRITE command at T0 and T5.
5. CA Parity = Disable, CS to CA Latency = Disable, Write DBI = Disable
6. The write recovery time (tWR) and write timing parameter (tWTR) are referenced from the first rising clock edge after the last write data shown at T18.

Figure 113 – Nonconsecutive WRITE (BL8) with 1tCK Preamble in Same or Different Bank Group

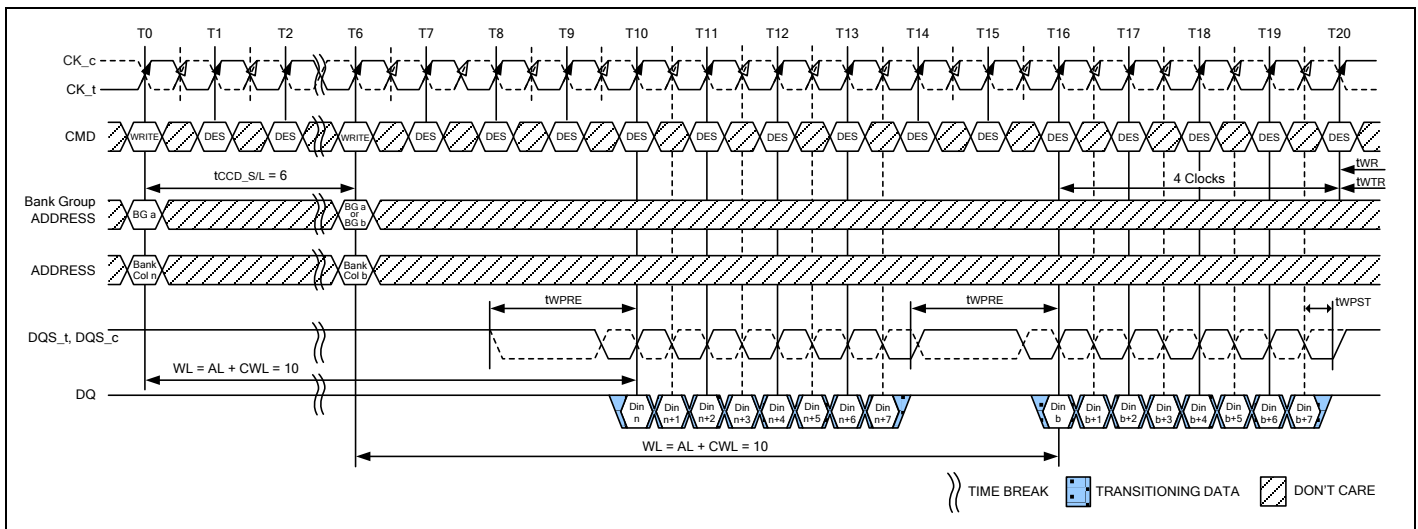

Notes:

1. BL = 8, AL = 0, CWL = 9 + 1 = 10^{*8}, Preamble = 2tCK, tCCD_S/L = 6
2. Din n (or b) = data-in to column n (or column b).
3. DES commands are shown for ease of illustration; other commands may be valid at these times.
4. BL8 setting activated by either MR0 A[1:0] = 00 or MR0 A[1:0] = 01 and A12 = 1 during WRITE command at T0 and T6.
5. CA Parity = Disable, CS to CA Latency = Disable, Write DBI = Disable
6. tCCD_S/L=5 isn't allowed in 2tCK preamble mode.
7. The write recovery time (tWR) and write timing parameter (tWTR) are referenced from the first rising clock edge after the last write data shown at T20.
8. When operating in 2tCK Write Preamble Mode, CWL must be programmed to a value at least 1 clock greater than the lowest CWL setting supported in the applicable tCK range. That means CWL = 9 isn't allowed when operating in 2tCK Write Preamble Mode.

Figure 114 – Nonconsecutive WRITE (BL8) with 2tCK Preamble in Same or Different Bank Group

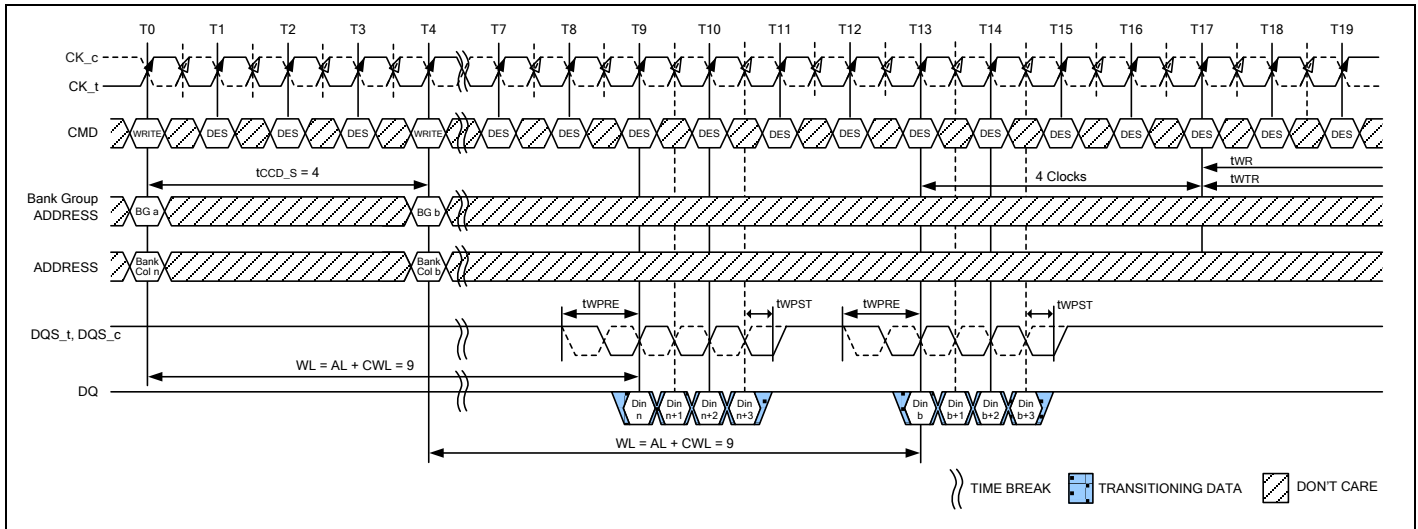

Notes:

1. BC = 4, AL = 0, CWL = 9, Preamble = 1tCK
2. Din n (or b) = data-in to column n (or column b).
3. DES commands are shown for ease of illustration; other commands may be valid at these times.
4. BC4 setting activated by MR0 A[1:0] = 01 and A12 = 0 during WRITE command at T0 and T4.
5. CA Parity = Disable, CS to CA Latency = Disable, Write DBI = Disable
6. The write recovery time (tWR) and write timing parameter (tWTR) are referenced from the first rising clock edge after the last write data shown at T17.

Figure 115 – WRITE (BC4) OTF to WRITE (BC4) OTF with 1tCK Preamble in Different Bank Group

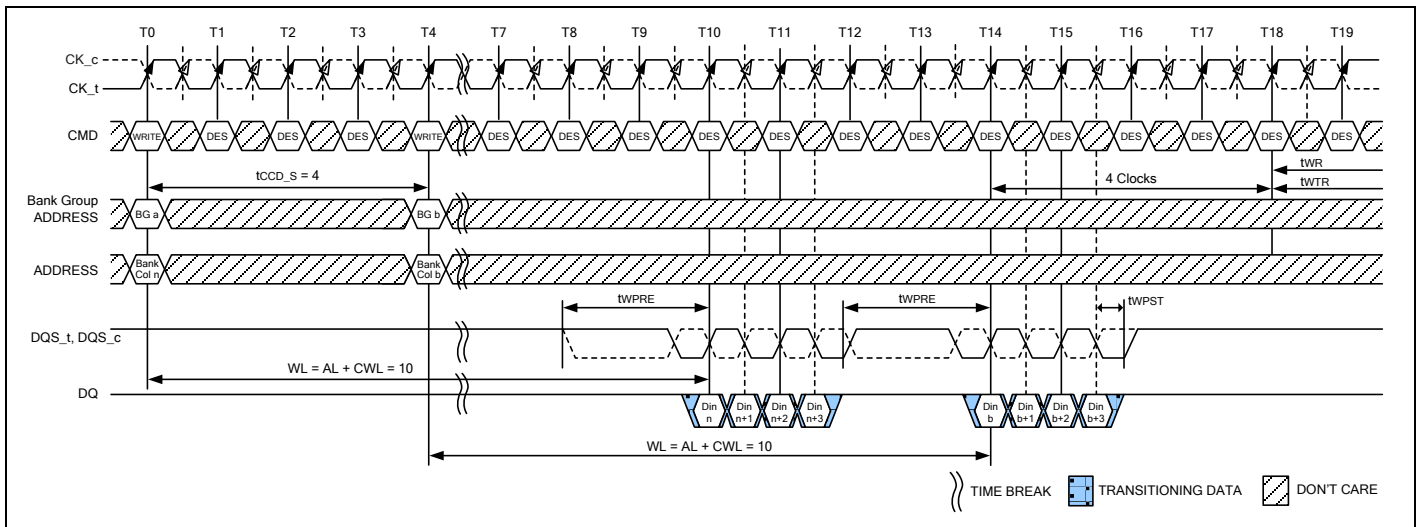

Notes:

1. BC = 4, AL = 0, CWL = 9 + 1 = 10^{*7}, Preamble = 2tCK
2. Din n (or b) = data-in to column n (or column b).
3. DES commands are shown for ease of illustration; other commands may be valid at these times.
4. BC4 setting activated by MR0 A[1:0] = 01 and A12 = 0 during WRITE command at T0 and T4.
5. CA Parity = Disable, CS to CA Latency = Disable, Write DBI = Disable
6. The write recovery time (tWR) and write timing parameter (tWTR) are referenced from the first rising clock edge after the last write data shown at T18.
7. When operating in 2tCK Write Preamble Mode, CWL must be programmed to a value at least 1 clock greater than the lowest CWL setting supported in the applicable tCK range. That means CWL = 9 isn't allowed when operating in 2tCK Write Preamble Mode.

Figure 116 – WRITE (BC4) OTF to WRITE (BC4) OTF with 2tCK Preamble in Different Bank Group

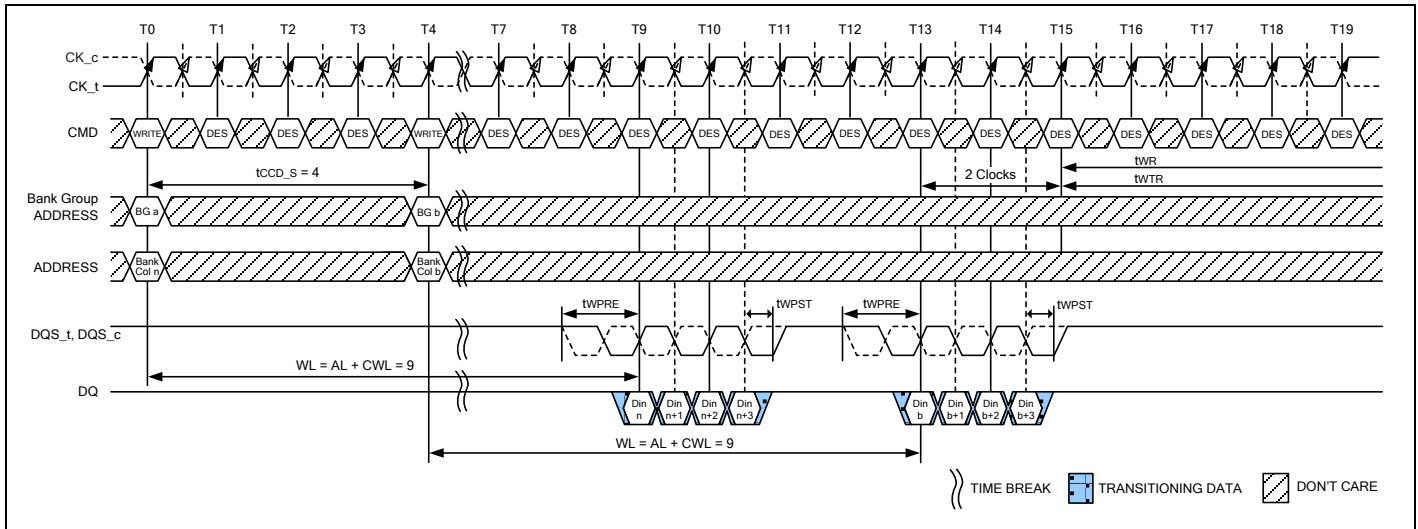

Notes:

1. BC = 4, AL = 0, CWL = 9, Preamble = 1tCK
2. Din n (or b) = data-in to column n (or column b).
3. DES commands are shown for ease of illustration; other commands may be valid at these times.
4. BC4 setting activated by MR0 A[1:0] = 10.
5. CA Parity = Disable, CS to CA Latency = Disable, Write DBI = Disable
6. The write recovery time (twR) and write timing parameter (twTR) are referenced from the first rising clock edge after the last write data shown at T15.

Figure 117 – WRITE (BC4) Fixed to WRITE (BC4) Fixed with 1tCK Preamble in Different Bank Group

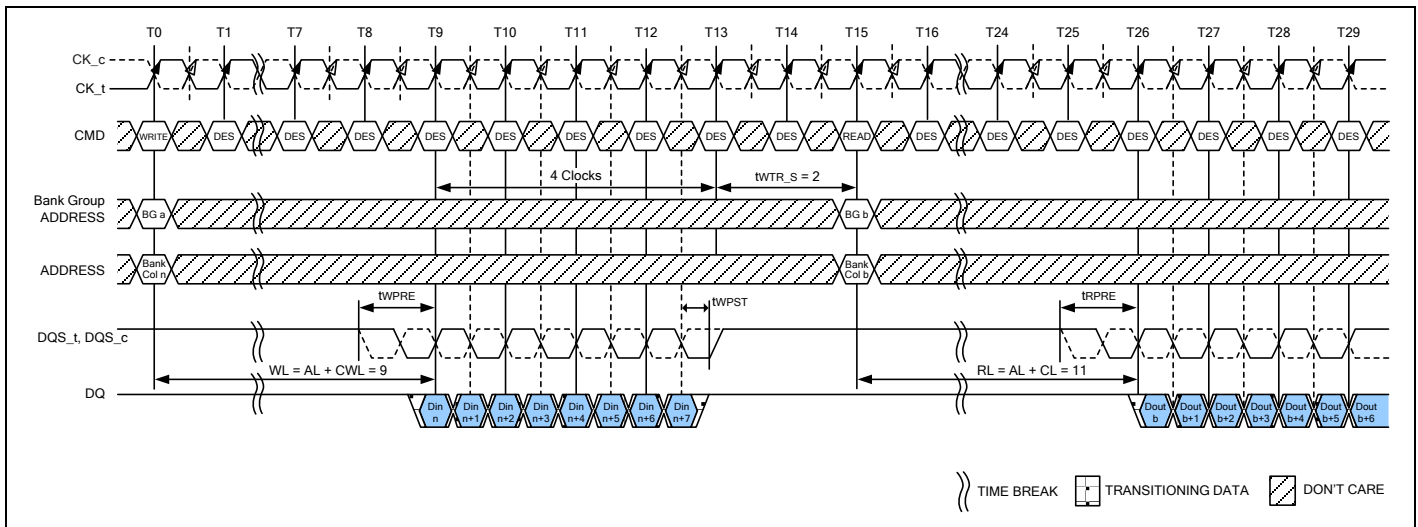

Notes:

1. BL = 8, AL = 0, CWL = 9, CL = 11, Write Preamble = 1tCK, RL = 11, Read Preamble = 1tCK
2. Din n = data-in to column n. Dout b = data-out from column b.
3. DES commands are shown for ease of illustration; other commands may be valid at these times.
4. BL8 setting activated by either MR0 A[1:0] = 00 or MR0 A[1:0] = 01 and A12 = 1 during WRITE command at T0 and READ command at T15.
5. CA Parity = Disable, CS to CA Latency = Disable, Write DBI = Disable
6. The write timing parameter (twTR_s) are referenced from the first rising clock edge after the last write data shown at T13.
When AL is non-zero, the external read command at T15 can be pulled in by AL.

Figure 118 – WRITE (BL8) to READ (BL8) with 1tCK Preamble in Different Bank Group

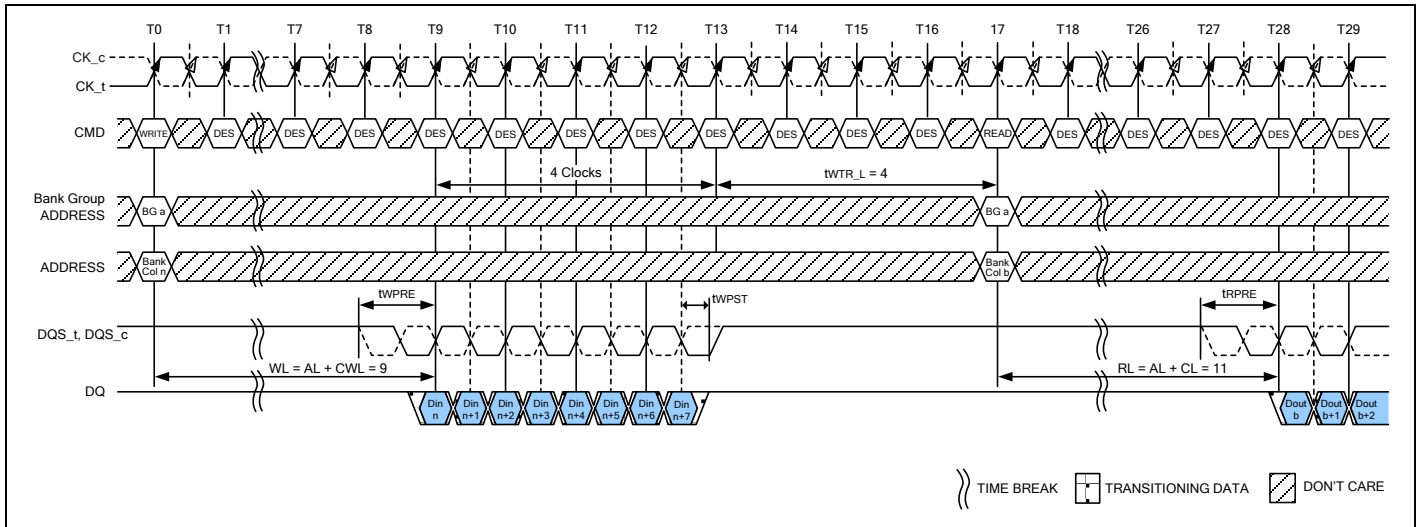

Notes:

1. BL = 8, AL = 0, CWL = 9, CL = 11, Write Preamble = 1tCK, RL = 11, Read Preamble = 1tCK
2. Din n = data-in to column n. Dout b = data-out from column b.
3. DES commands are shown for ease of illustration; other commands may be valid at these times.
4. BL8 setting activated by either MR0 A[1:0] = 00 or MR0 A[1:0] = 01 and A12 = 1 during WRITE command at T0 and READ command at T17.
5. CA Parity = Disable, CS to CA Latency = Disable, Write DBI = Disable
6. The write timing parameter (twTR_L) are referenced from the first rising clock edge after the last write data shown at T13. When AL is non-zero, the external read command at T17 can be pulled in by AL.

Figure 119 – WRITE (BL8) to READ (BL8) with 1tCK Preamble in Same Bank Group

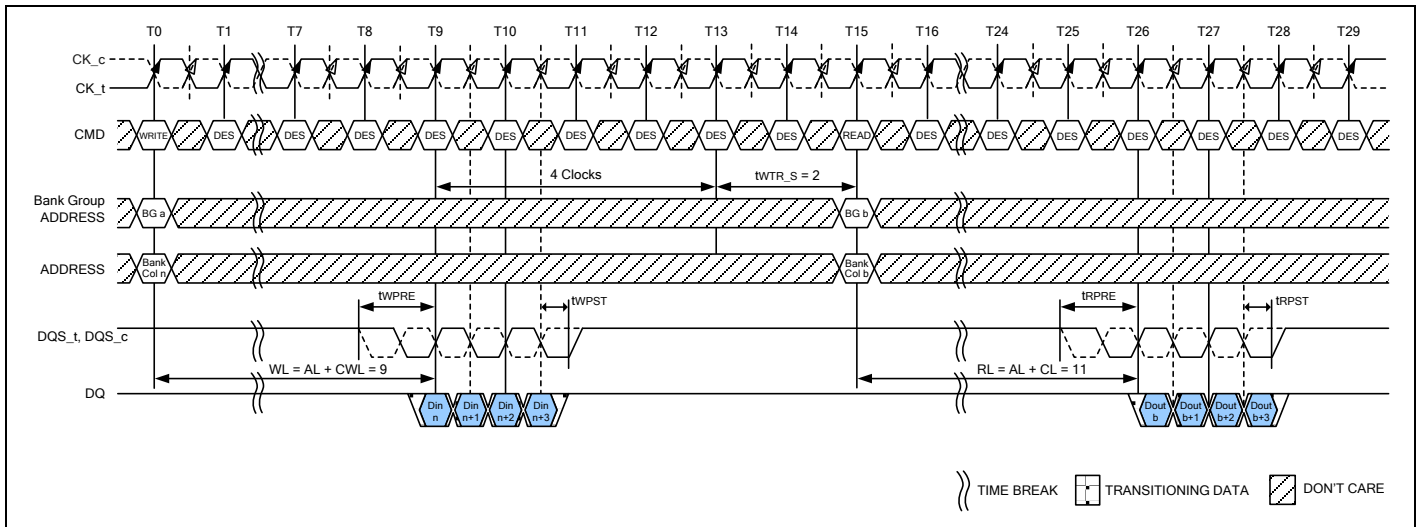

Notes:

1. BC = 4, AL = 0, CWL = 9, CL = 11, Write Preamble = 1tCK, RL = 11, Read Preamble = 1tCK
2. Din n = data-in to column n. Dout b = data-out from column b.
3. DES commands are shown for ease of illustration; other commands may be valid at these times.
4. BC4 setting activated by MR0 A[1:0] = 01 and A12 = 0 during WRITE command at T0 and READ command at T15.
5. CA Parity = Disable, CS to CA Latency = Disable, Write DBI = Disable
6. The write timing parameter (twTR_S) are referenced from the first rising clock edge after the last write data shown at T13. When AL is non-zero, the external read command at T15 can be pulled in by AL.

Figure 120 – WRITE (BC4) OTF to READ (BC4) OTF with 1tCK Preamble in Different Bank Group

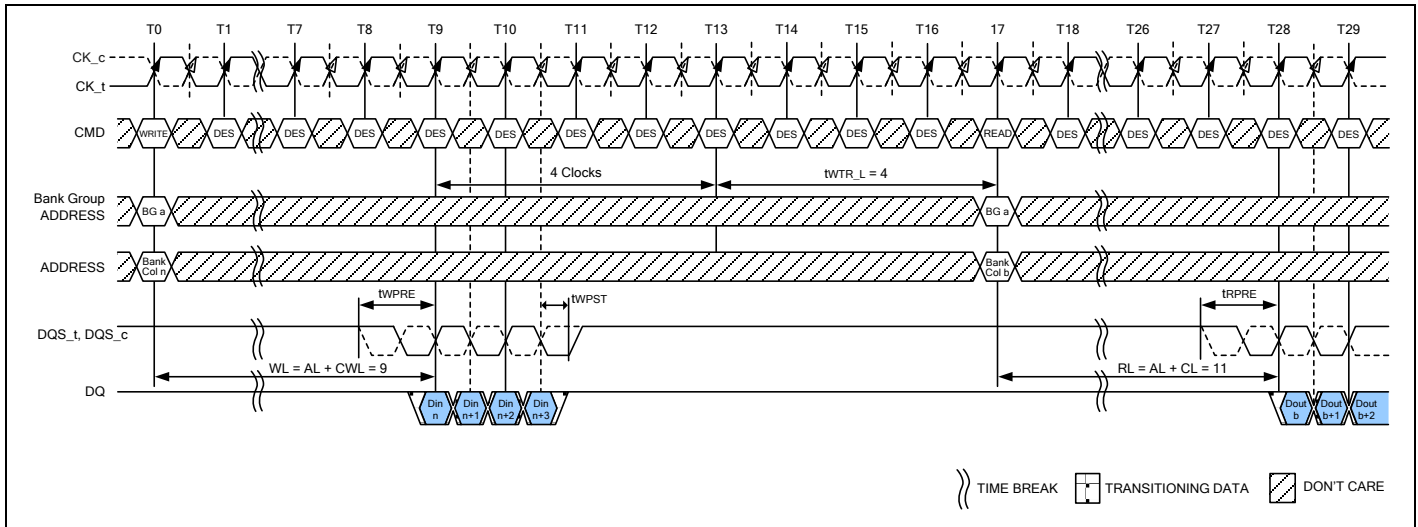

Notes:

1. BC = 4, AL = 0, CWL = 9, CL = 11, Write Preamble = 1tCK, RL = 11, Read Preamble = 1tCK
2. Din n = data-in to column n. Dout b = data-out from column b.
3. DES commands are shown for ease of illustration; other commands may be valid at these times.
4. BC4 setting activated by MR0 A[1:0] = 01 and A12 = 0 during WRITE command at T0 and READ command at T17.
5. CA Parity = Disable, CS to CA Latency = Disable, Write DBI = Disable
6. The write timing parameter (twTR_L) are referenced from the first rising clock edge after the last write data shown at T13. When AL is non-zero, the external read command at T17 can be pulled in by AL.

Figure 121 – WRITE (BC4) OTF to READ (BC4) OTF with 1tCK Preamble in Same Bank Group

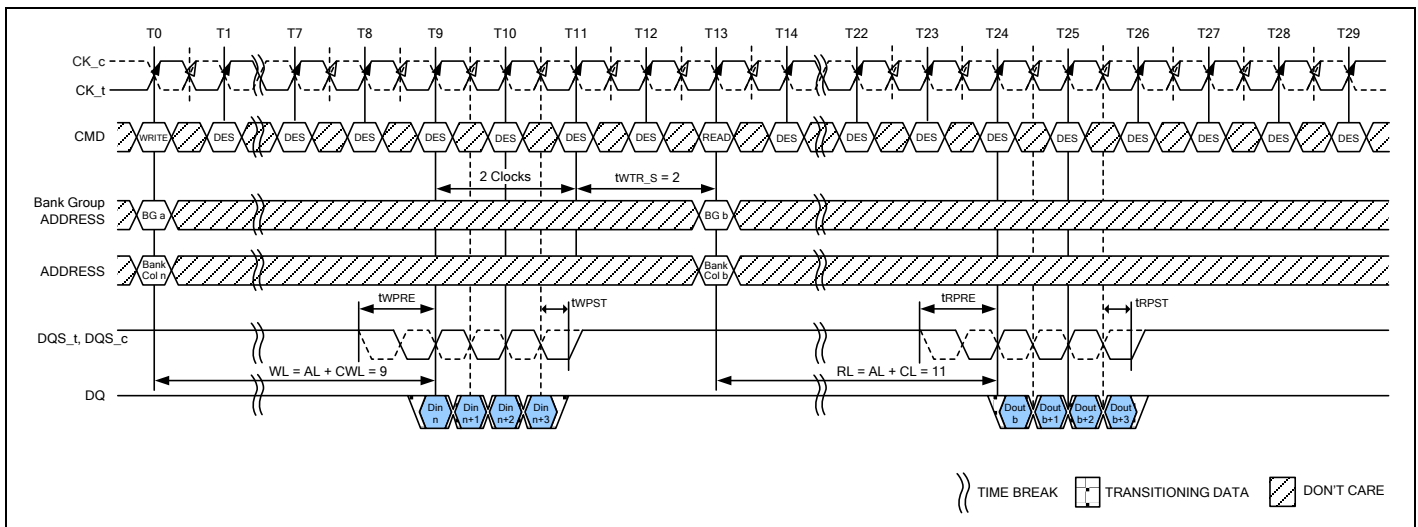

Notes:

1. BC = 4, AL = 0, CWL = 9, CL = 11, Write Preamble = 1tCK, RL = 11, Read Preamble = 1tCK
2. Din n = data-in to column n. Dout b = data-out from column b.
3. DES commands are shown for ease of illustration; other commands may be valid at these times.
4. BC4 setting activated by MR0 A[1:0] = 10.
5. CA Parity = Disable, CS to CA Latency = Disable, Write DBI = Disable
6. The write timing parameter (twTR_S) are referenced from the first rising clock edge after the last write data shown at T11. When AL is non-zero, the external read command at T23 can be pulled in by AL.

Figure 122 – WRITE (BC4) Fixed to READ (BC4) Fixed with 1tCK Preamble in Different Bank Group

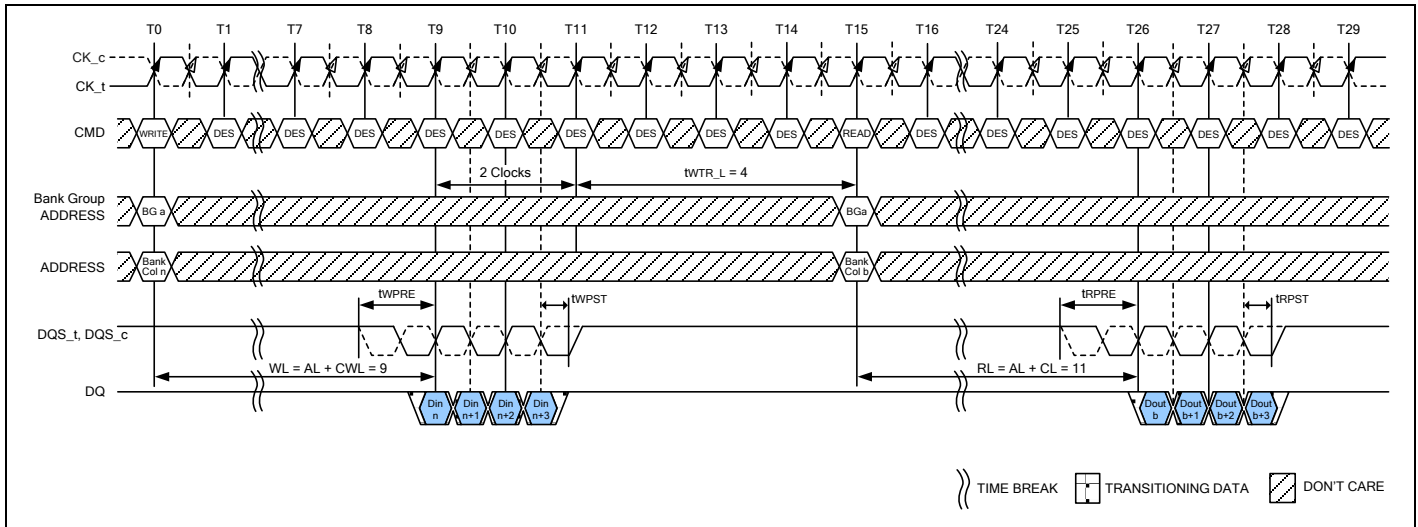

Notes:

1. BC = 4, AL = 0, CWL = 9, CL = 11, Write Preamble = 1tCK, RL = 11, Read Preamble = 1tCK
2. Din n = data-in to column n. Dout b = data-out from column b.
3. DES commands are shown for ease of illustration; other commands may be valid at these times.
4. BC4 setting activated by MR0 A[1:0] = 10.
5. CA Parity = Disable, CS to CA Latency = Disable, Write DBI = Disable
6. The write timing parameter (twTR_L) are referenced from the first rising clock edge after the last write data shown at T11. When AL is non-zero, the external read command at T15 can be pulled in by AL.

Figure 123 – WRITE (BC4) Fixed to READ (BC4) Fixed with 1tCK Preamble in Same Bank Group

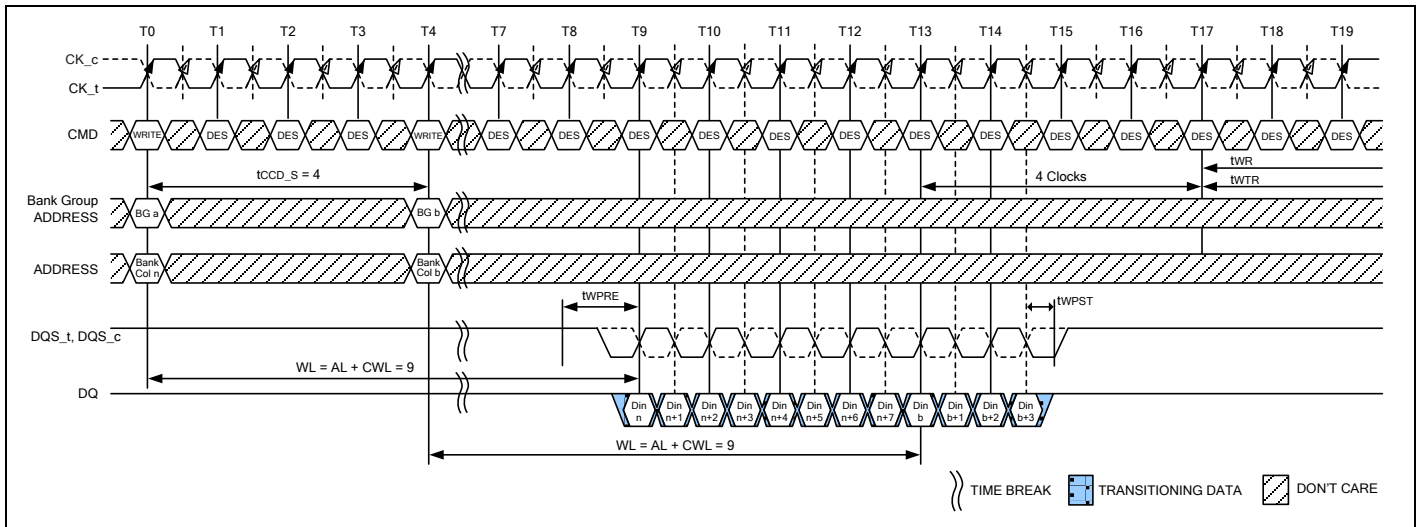

Notes:

1. BL = 8 / BC = 4, AL = 0, CWL = 9, Preamble = 1tCK
2. Din n (or b) = data-in to column n (or column b).
3. DES commands are shown for ease of illustration; other commands may be valid at these times.
4. BL8 setting activated by MR0 A[1:0] = 01 and A12 = 1 during WRITE command at T0. BC4 setting activated by MR0 A[1:0] = 01 and A12 = 0 during WRITE command at T4.
5. CA Parity = Disable, CS to CA Latency = Disable, Write DBI = Disable
6. The write recovery time (twR) and write timing parameter (twTR) are referenced from the first rising clock edge after the last write data shown at T17.

Figure 124 – WRITE (BL8) to WRITE (BC4) OTF with 1tCK Preamble in Different Bank Group

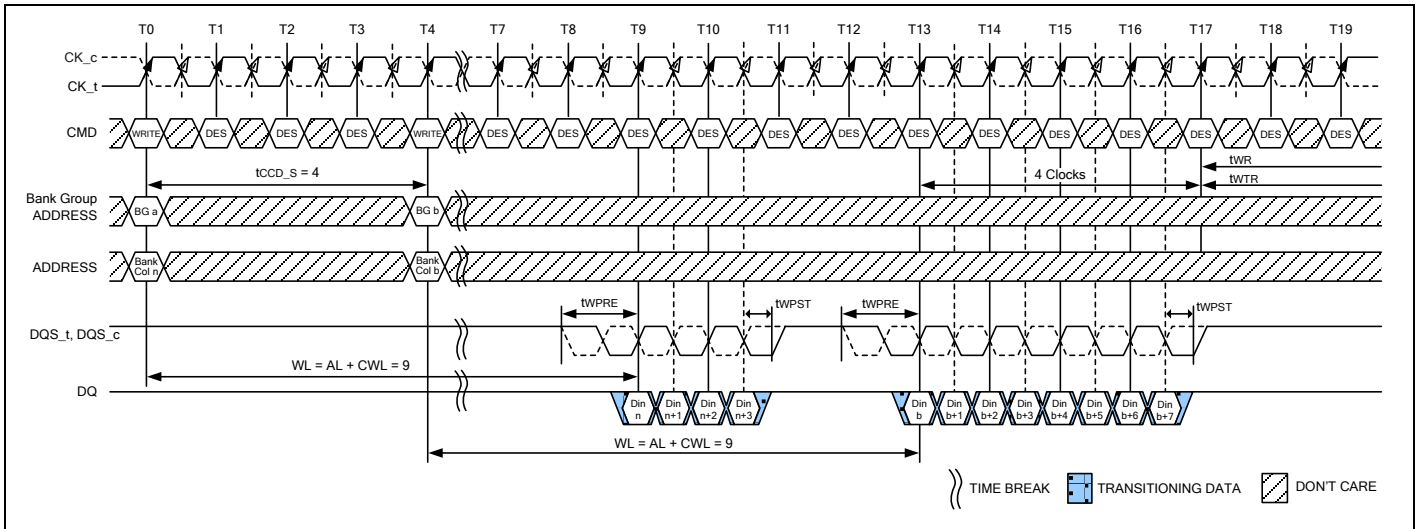

Notes:

1. BC = 4 / BL = 8, AL = 0, CWL = 9, Preamble = 1tCK
2. Din n (or b) = data-in to column n (or column b).
3. DES commands are shown for ease of illustration; other commands may be valid at these times.
4. BC4 setting activated by MR0 A[1:0] = 01 and A12 = 0 during WRITE command at T0.
BL8 setting activated by MR0 A[1:0] = 01 and A12 = 1 during WRITE command at T4.
5. CA Parity = Disable, CS to CA Latency = Disable, Write DBI = Disable
6. The write recovery time (tWR) and write timing parameter (tWTR) are referenced from the first rising clock edge after the last write data shown at T17.

Figure 125 – WRITE (BC4) OTF to WRITE (BL8) with 1tCK Preamble in Different Bank Group

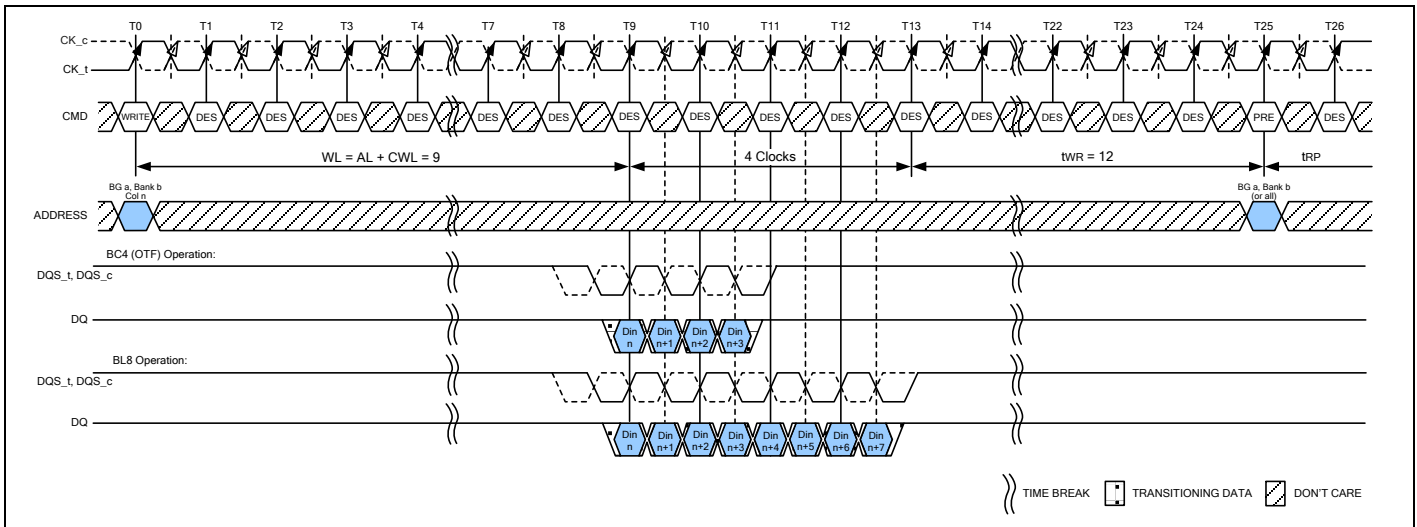

Notes:

1. BL = 8 / BC = 4, AL = 0, CWL = 9, Preamble = 1tCK, tWR = 12
2. Din n = data-in to column n.
3. DES commands are shown for ease of illustration; other commands may be valid at these times.
4. BC4 setting activated by MR0 A[1:0] = 01 and A12 = 0 during WRITE command at T0.
BL8 setting activated by MR0 A[1:0] = 00 or MR0 A[1:0] = 01 and A12 = 1 during WRITE command at T0.
5. CA Parity = Disable, CS to CA Latency = Disable, Write DBI = Disable
6. The write recovery time (tWR) is referenced from the first rising clock edge after the last write data shown at T13.
tWR specifies the last burst write cycle until the precharge command can be issued to the same bank.

Figure 126 – WRITE (BL8/BC4 OTF) to PRECHARGE Operation with 1tCK Preamble

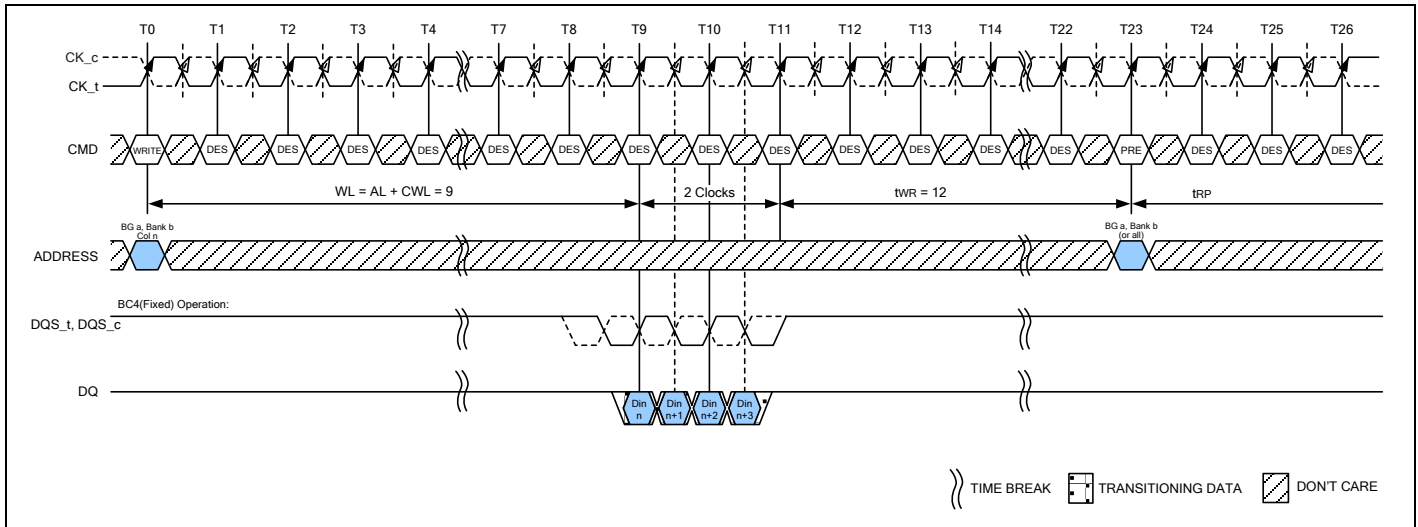

Notes:

1. BC = 4, AL = 0, CWL = 9, Preamble = 1tCK, tWR = 12
2. Din n = data-in to column n.
3. DES commands are shown for ease of illustration; other commands may be valid at these times.
4. BC4 setting activated by MR0 A[1:0] = 10.
5. CA Parity = Disable, CS to CA Latency = Disable, Write DBI = Disable
6. The write recovery time (tWR) is referenced from the first rising clock edge after the last write data shown at T11. tWR specifies the last burst write cycle until the precharge command can be issued to the same bank.

Figure 127 – WRITE (BC4) Fixed to PRECHARGE Operation with 1tCK Preamble

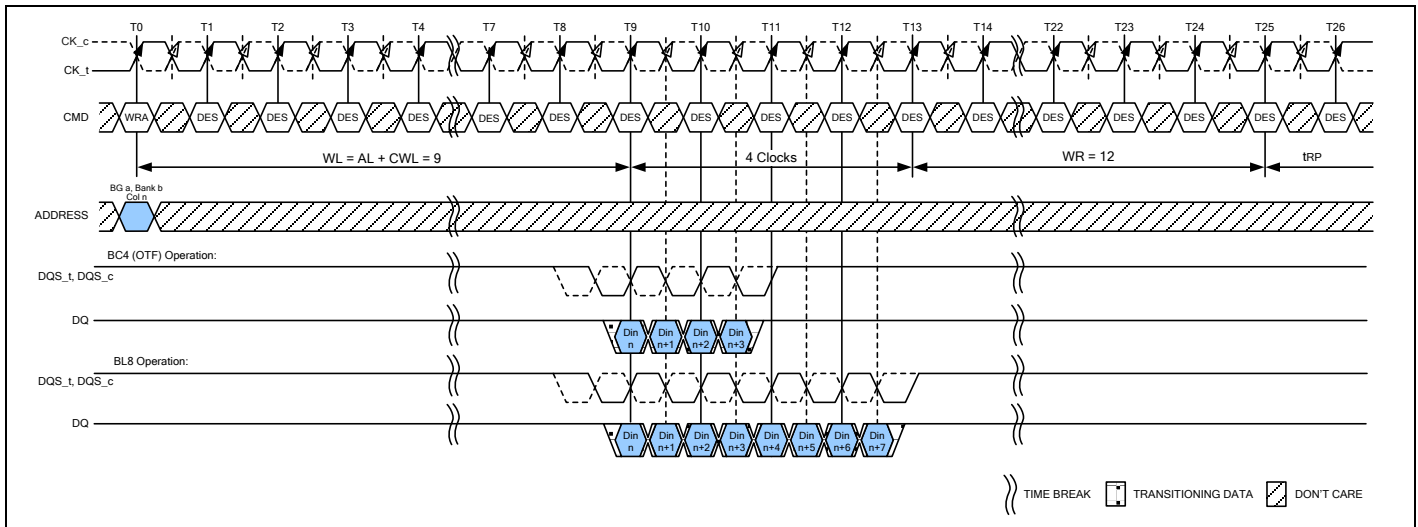

Notes:

1. BL = 8 / BC = 4, AL = 0, CWL = 9, Preamble = 1tck, WR = 12
2. Din n = data-in to column n.
3. DES commands are shown for ease of illustration; other commands may be valid at these times.
4. BC4 setting activated by MR0 A[1:0] = 01 and A12 = 0 during WRITE command at T0. BL8 setting activated by either MR0 A[1:0] = 00 or MR0 A[1:0] = 01 and A12 = 1 during WRITE command at T0.
5. CA Parity = Disable, CS to CA Latency = Disable, Write DBI = Disable
6. The write recovery time (WR) is referenced from the first rising clock edge after the last write data shown at T13. WR specifies the last burst write cycle until the precharge command can be issued to the same bank.

Figure 128 – WRITE (BL8/BC4 OTF) with Auto PRECHARGE Operation and 1tCK Preamble

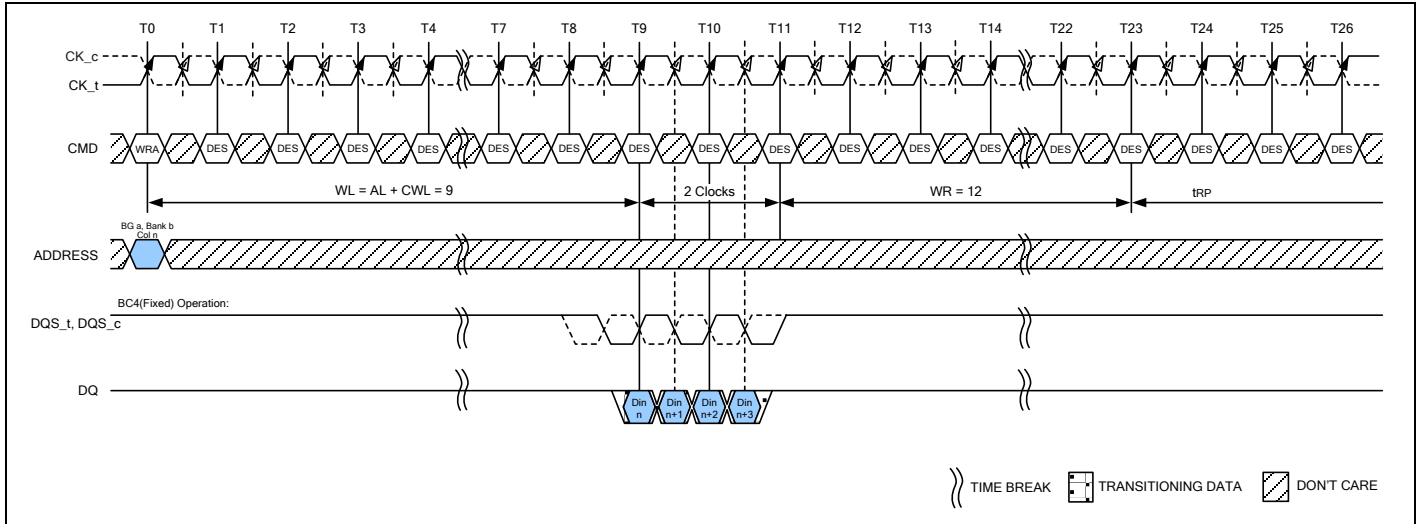

Notes:

1. BC = 4, AL = 0, CWL = 9, Preamble = 1tCK, WR = 12
2. Din n = data-in to column n.
3. DES commands are shown for ease of illustration; other commands may be valid at these times.
4. BC4 setting activated by MR0 A[1:0] = 10.
5. CA Parity = Disable, CS to CA Latency = Disable, Write DBI = Disable
6. The write recovery time (WR) is referenced from the first rising clock edge after the last write data shown at T11. WR specifies the last burst write cycle until the precharge command can be issued to the same bank.

Figure 129 – WRITE (BC4) Fixed with Auto PRECHARGE Operation and 1tCK Preamble

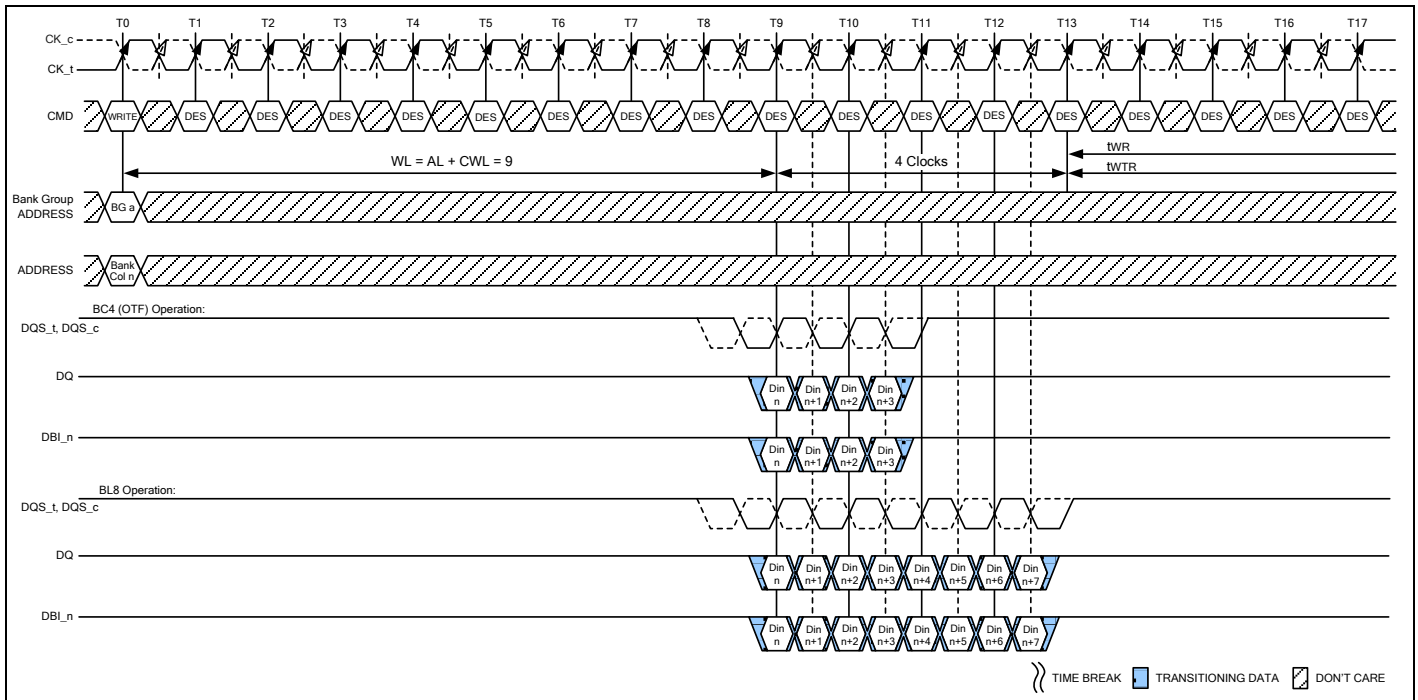

Notes:

1. BL = 8 / BC = 4, AL = 0, CWL = 9, Preamble = 1tCK
2. Din n = data-in to column n.
3. DES commands are shown for ease of illustration; other commands may be valid at these times.
4. BC4 setting activated by MR0 A[1:0] = 01 and A12 = 0 during WRITE command at T0. BL8 setting activated by either MR0 A[1:0] = 00 or MR0 A[1:0] = 01 and A12 = 1 during WRITE command at T0.
5. CA Parity = Disable, CS to CA Latency = Disable, Write DBI = Enable, CRC = Disable
6. The write recovery time (tWR_DBI) and write timing parameter (tWTR_DBI) are referenced from the first rising clock edge after the last write data shown at T13.

Figure 130 – WRITE (BL8/BC4 OTF) with 1tCK Preamble and DBI

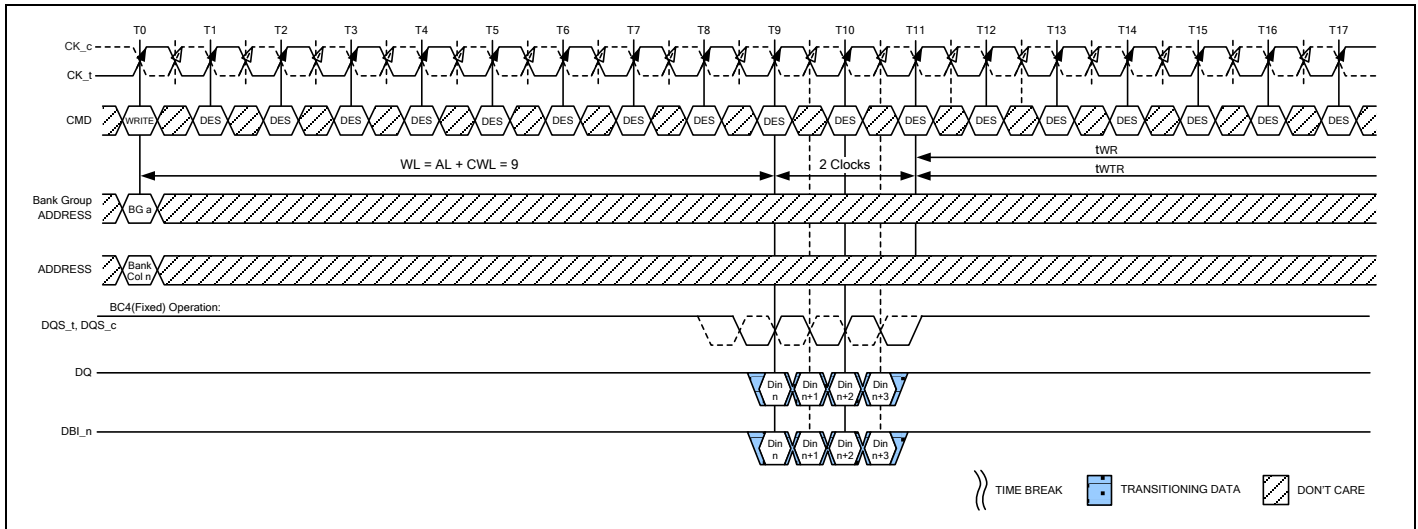

Notes:

1. BC = 4, AL = 0, CWL = 9, Preamble = 1tck
2. Dinn = data-in to column n.
3. DES commands are shown for ease of illustration; other commands may be valid at these times.
4. BC4 setting activated by MR0 A[1:0] = 10.
5. CA Parity = Disable, CS to CA Latency = Disable, Write DBI = Enable, CRC = Disable
6. The write recovery time (tWR_DBI) and write timing parameter (tWTR_DBI) are referenced from the first rising clock edge after the last write data shown at T11.

Figure 131 – WRITE (BC4) Fixed with 1tCK Preamble and DBI

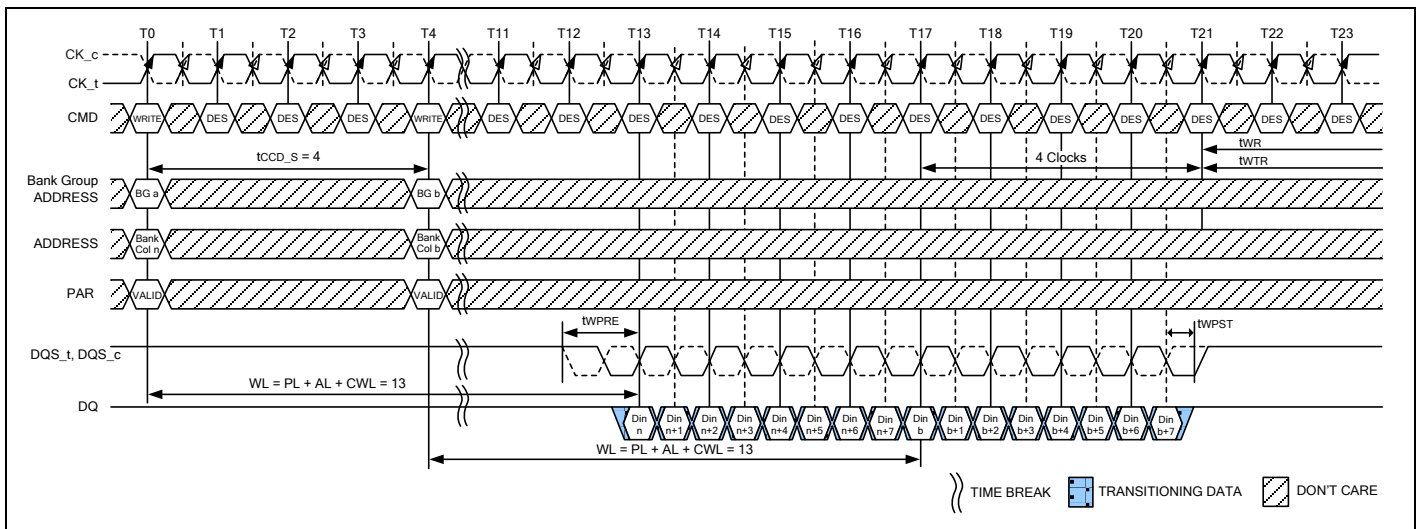

Notes:

1. BL = 8, AL = 0, CWL = 9, PL = 4, Preamble = 1tCK
2. Din n (or b) = data-in to column n (or column b).
3. DES commands are shown for ease of illustration; other commands may be valid at these times.
4. BL8 setting activated by either MR0 A[1:0] = 00 or MR0 A[1:0] = 01 and A12 = 1 during WRITE command at T0 and T4.
5. CA Parity = Enable, CS to CA Latency = Disable, Write DBI = Disable
6. The write recovery time (tWR) and write timing parameter (tWTR) are referenced from the first rising clock edge after the last write data shown at T21.

Figure 132 – Consecutive WRITE (BL8) with 1tCK Preamble and CA Parity in Different Bank Group

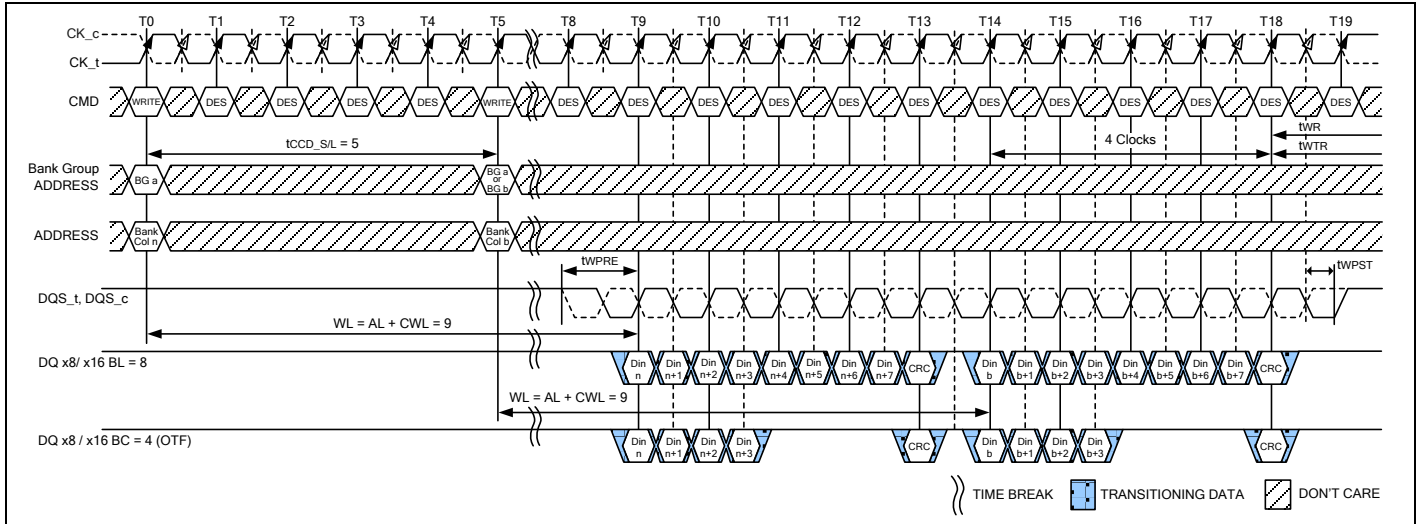

Notes:

1. BL = 8/BC = 4, AL = 0, CWL = 9, Preamble = 1tCK, tCCD_S/L = 5
2. Din n (or b) = data-in to column n (or column b).
3. DES commands are shown for ease of illustration; other commands may be valid at these times.
4. BL8 setting activated by either MR0 A[1:0] = 00 or MR0 A[1:0] = 01 and A12 = 1 during WRITE command at T0 and T5.
5. BC4 setting activated by MR0 A[1:0] = 01 and A12 = 0 during WRITE command at T0 and T5.
6. CA Parity = Disable, CS to CA Latency = Disable, Write DBI = Disable, Write CRC = Enable
7. The write recovery time (tWR) and write timing parameter (tWTR) are referenced from the first rising clock edge after the last write data shown at T18

Figure 133 – Consecutive WRITE (BL8/BC4 OTF) with 1tCK Preamble and Write CRC in Same or Different Bank Group

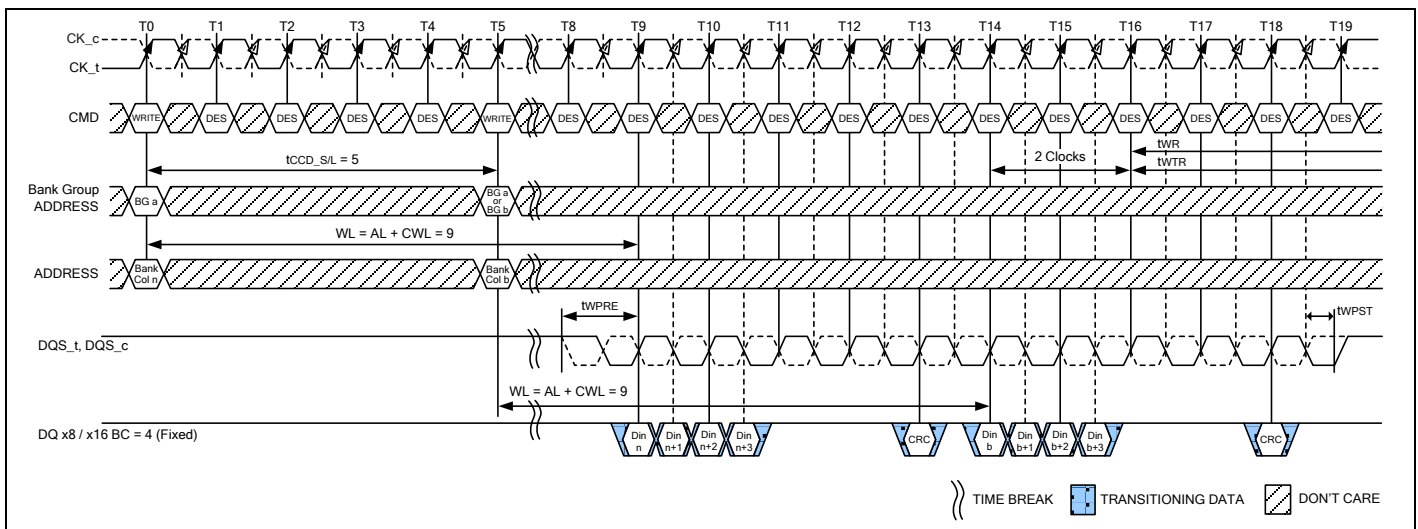

Notes:

1. BC4 (Fixed), AL = 0, CWL = 9, Preamble = 1tCK, tCCD_S/L = 5
2. Din n (or b) = data-in to column n (or column b).
3. DES commands are shown for ease of illustration; other commands may be valid at these times.
4. BL4 setting activated by MR0 A[1:0] = 10 at T0 and T5.
5. CA Parity = Disable, CS to CA Latency = Disable, Write DBI = Disable, Write CRC = Enable
6. The write recovery time (tWR) and write timing parameter (tWTR) are referenced from the first rising clock edge after the last write data shown at T16.

Figure 134 – Consecutive WRITE (BC4) Fixed with 1tCK Preamble and Write CRC in Same or Different Bank Group

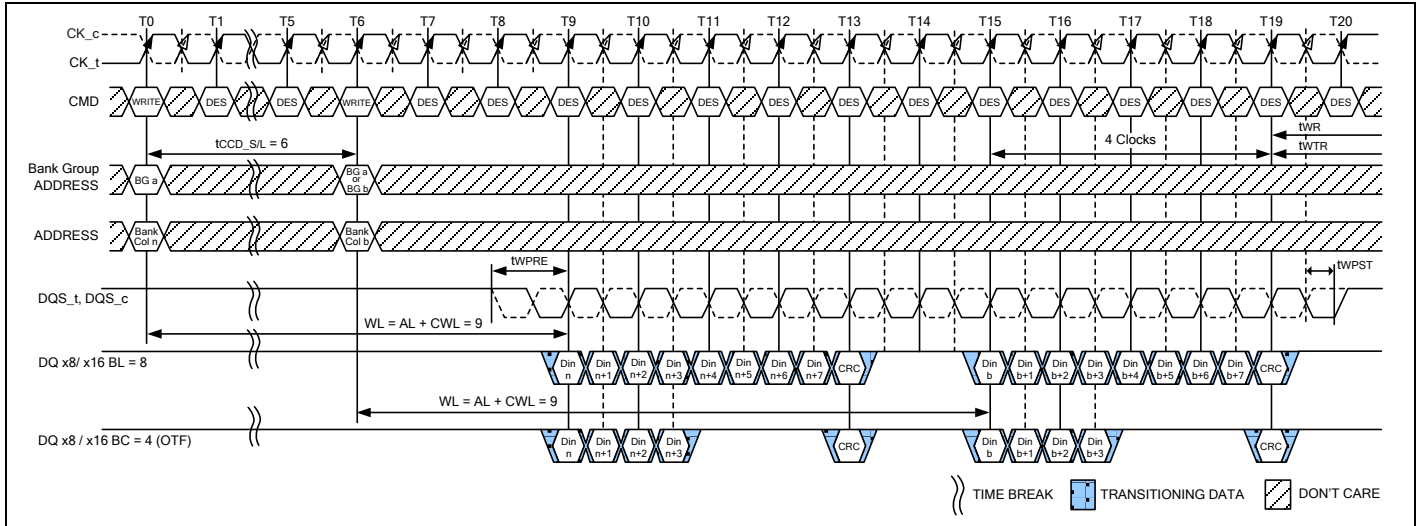

Notes:

1. (BL8/BC4 OTF), AL = 0, CWL = 9, Preamble = 1tCK, tCCD_S/L = 6
2. Din n (or b) = data-in to column n (or column b).
3. DES commands are shown for ease of illustration; other commands may be valid at these times.
4. BL8 setting activated by either MR0 A[1:0] = 00 or MR0 A[1:0] = 01 and A12 = 1 during WRITE command at T0 and T6.
5. BC4 setting activated by MR0 A[1:0] = 01 and A12 = 0 during WRITE command at T0 and T6.
6. CA Parity = Disable, CS to CA Latency = Disable, Write DBI = Disable, Write CRC = Enable
7. The write recovery time (tWR) and write timing parameter (tWTR) are referenced from the first rising clock edge after the last write data shown at T19.

Figure 135 – Nonconsecutive WRITE (BL8/BC4 OTF) with 1tCK Preamble and Write CRC in Same or Different Bank Group

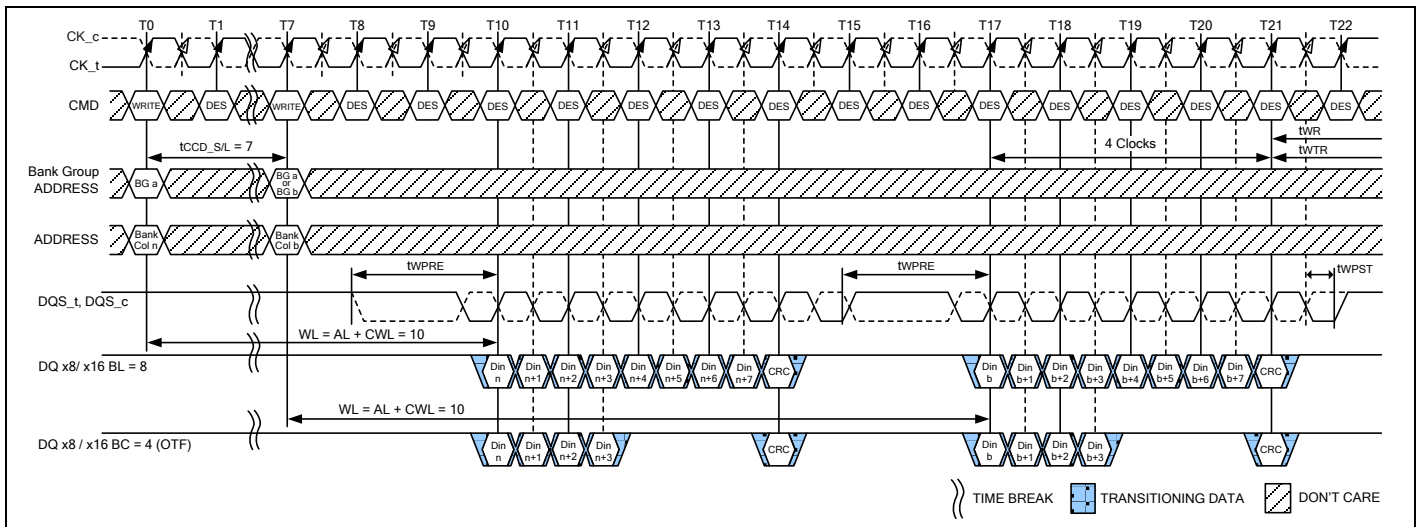

Notes:

1. (BL8/BC4 OTF), AL = 0, CWL = 9 + 1 = 10^{ns}, Preamble = 2tCK, tCCD_S/L = 7
2. Din n (or b) = data-in to column n (or column b).
3. DES commands are shown for ease of illustration; other commands may be valid at these times.
4. BL8 setting activated by either MR0 A[1:0] = 00 or MR0 A[1:0] = 01 and A12 = 1 during WRITE command at T0 and T7.
5. BC4 setting activated by MR0 A[1:0] = 01 and A12 = 0 during WRITE command at T0 and T7.
6. CA Parity = Disable, CS to CA Latency = Disable, Write DBI = Disable, Write CRC = Enable
7. tCCD_S/L = 6 isn't allowed in 2tCK preamble mode.
8. The write recovery time (tWR) and write timing parameter (tWTR) are referenced from the first rising clock edge after the last write data shown at T21.
9. When operating in 2tCK Write Preamble Mode, CWL must be programmed to a value at least 1 clock greater than the lowest CWL setting supported in the applicable tCK range. That means CWL = 9 is not allowed when operating in 2tCK Write Preamble Mode

Figure 136 – Nonconsecutive WRITE (BL8/BC4 OTF) with 2tCK Preamble and Write CRC in Same or Different Bank Group

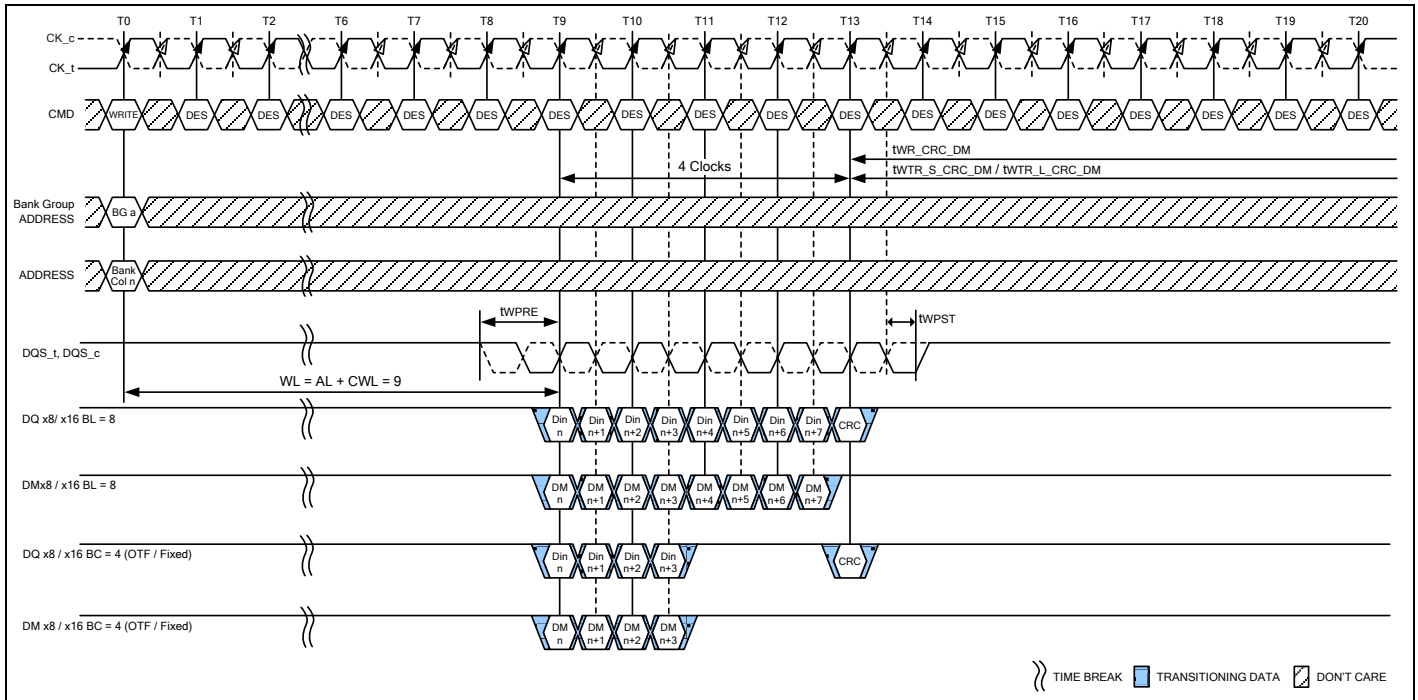

Notes:

1. BL = 8 / BC = 4, AL = 0, CWL = 9, Preamble = 1tCK
2. Din n = data-in to column n.
3. DES commands are shown for ease of illustration; other commands may be valid at these times.
4. BL8 setting activated by either MR0 A[1:0] = 00 or MR0 A[1:0] = 01 and A12 = 1 during WRITE command at T0.
5. BC4 setting activated by either MR0 A[1:0] = 10 or MR0 A[1:0] = 01 and A12 = 0 during WRITE command at T0.
6. CA Parity = Disable, CS to CA Latency = Disable, Write DBI = Disable, Write CRC = Enable, DM = Enable
7. The write recovery time (tWR_CRC_DM) and write timing parameter (tWR_S_CRC_DM/tWR_L_CRC_DM) are referenced from the first rising clock edge after the last write data shown at T13.

Figure 137 – WRITE (BL8/BC4 OTF/Fixed) with 1tCK Preamble and Write CRC and DM in Same or Different Bank Group

9.27.6 Read and Write Command Interval

Table 47 – Minimum Read and Write Command Timings

Bank Group	Timing Parameter	DDR4-1600 / 1866 / 2133 / 2400/ 2666 / 3200	Notes
same	Minimum Read to Write	CL - CWL + RBL / 2 + 1 tCK + tWPRE	1, 2
	Minimum Read after Write	CWL + WBL / 2 + tWTR_L	1, 3
different	Minimum Read to Write	CL - CWL + RBL / 2 + 1 tCK + tWPRE	1, 2
	Minimum Read after Write	CWL + WBL / 2 + tWTR_S	1, 3

Notes:

1. These timings require extended calibrations times tZQinit and tZQCS.
2. RBL: Read burst length associated with Read command
RBL = 8 for fixed 8 and on-the-fly mode 8
RBL = 4 for fixed BC4 and on-the-fly mode BC4
3. WBL: Write burst length associated with Write command
WBL = 8 for fixed 8 and on-the-fly mode 8 or BC4
WBL = 4 for fixed BC4 only



9.27.7 Write Timing Violations

9.27.7.1 Motivation

Generally, if Write timing parameters are violated, a complete reset/initialization procedure has to be initiated to make sure that the DRAM works properly. However, it is desirable, for certain violations as specified below, the DRAM is guaranteed to not “hang up,” and that errors are limited to that particular operation.

For the following, it will be assumed that there are no timing violations with regards to the Write command itself (including ODT, etc.) and that it does satisfy all timing requirements not mentioned below.

9.27.7.2 Data Setup and Hold Offset Violations

Should the data to strobe timing requirements (t_{DQS_off} , t_{DQH_off} , $t_{DQS_dd_off}$, $t_{DQH_dd_off}$) be violated, for any of the strobe edges associated with a write burst, then wrong data might be written to the memory locations addressed with this WRITE command. In the example (Figure 109), the relevant strobe edges for write burst A are associated with the clock edges: T9, T9.5, T10, T10.5, T11, T11.5, T12 and T12.5.

Subsequent reads from that location might result in unpredictable read data, however the DRAM will work properly otherwise.

9.27.7.3 Strobe and Strobe to Clock Timing Violations

Should the strobe timing requirements (t_{DQSH} , t_{DQSL} , t_{WPRE} , t_{WPST}) or the strobe to clock timing requirements (t_{DSS} , t_{DSH} , t_{DQSS}) be violated for any of the strobe edges associated with a Write burst, then wrong data might be written to the memory location addressed with the offending WRITE command. Subsequent reads from that location might result in unpredictable read data, however the DRAM will work properly otherwise with the following constraints:

- (1) Both Write CRC and data burst OTF are disabled; timing specifications other than t_{DQSH} , t_{DQSL} , t_{WPRE} , t_{WPST} , t_{DSS} , t_{DSH} , t_{DQSS} are not violated.
- (2) The offending write strobe (and preamble) arrive no earlier or later than six DQS transition edges from the Write-Latency position.
- (3) A Read command following an offending Write command from any open bank is allowed.
- (4) One or more subsequent WR or a subsequent WRA {to same bank as offending WR} may be issued t_{CCD_L} later but incorrect data could be written; subsequent WR and WRA can be either offending or non-offending Writes. Reads from these Writes may provide incorrect data.
- (5) One or more subsequent WR or a subsequent WRA {to a different bank group} may be issued t_{CCD_S} later but incorrect data could be written; subsequent WR and WRA can be either offending or non-offending Writes. Reads from these Writes may provide incorrect data.
- (6) Once one or more precharge commands (PRE or PREA) are issued to DDR4 after offending WRITE command and all banks become precharged state (idle state), a subsequent, non-offending WR or WRA to any open bank shall be able to write correct data.

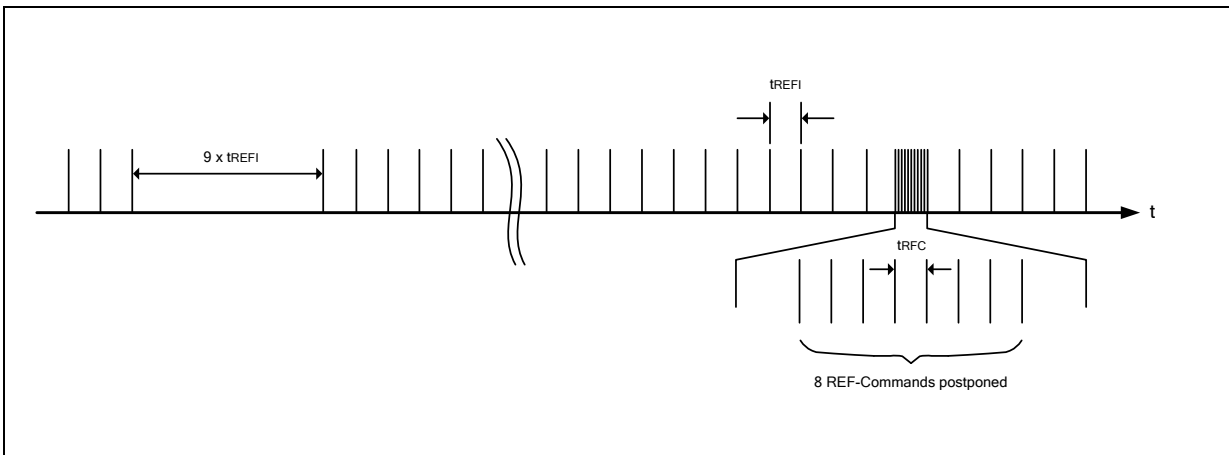

Figure 139 – Postponing Refresh Commands (Example of 1X Refresh mode)

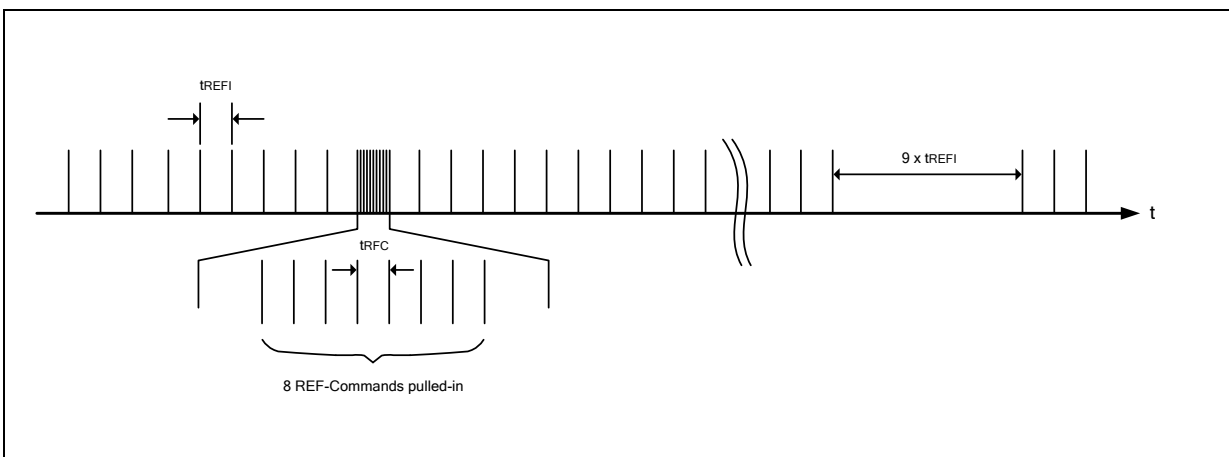

Figure 140 – Pulling-in Refresh Commands (Example of 1X Refresh mode)

9.29 Self Refresh Operation

The Self-Refresh command can be used to retain data in the DDR4 SDRAM, even if the rest of the system is powered down. When in the Self-Refresh mode, the DDR4 SDRAM retains data without external clocking. The DDR4 SDRAM device has a built-in timer to accommodate Self-Refresh operation. The Self-Refresh-Entry (SRE) Command is defined by having CS_n, RAS_n/A16, CAS_n/A15, and CKE held low with WE_n/A14 and ACT_n high at the rising edge of the clock.

Before issuing the Self-Refresh-Entry command, the DDR4 SDRAM must be idle with all bank precharge state with t_{RP} satisfied. 'Idle state' is defined as all banks are closed (t_{RP}, t_{DAL}, etc. satisfied), no data bursts are in progress, CKE is high, and all timings from previous operations are satisfied (t_{MRD}, t_{MOD}, t_{RFC}, t_{ZQinit}, t_{ZQoper}, t_{ZQCS}, etc.). Deselect command must be registered on last positive clock edge before issuing Self Refresh Entry command. Once the Self Refresh Entry command is registered, Deselect command must also be registered at the next positive clock edge. Once the Self-Refresh Entry command is registered, CKE must be held low to keep the device in Self-Refresh mode. DRAM automatically disables ODT termination and set Hi-Z as termination state regardless of ODT pin and RTT_PARK set when it enters in Self-Refresh mode. Upon exiting Self-Refresh, DRAM automatically enables ODT termination and set RTT_PARK asynchronously during t_{XSLL} when RTT_PARK is enabled. During normal operation (DLL on) the DLL is automatically disabled upon entering Self-Refresh and is automatically enabled (including a DLL-Reset) upon exiting Self-Refresh.



When the DDR4 SDRAM has entered Self-Refresh mode, all of the external control signals, except CKE and RESET_n, are “don’t care.” For proper Self-Refresh operation, all power supply and reference pins (VDD, VDDQ, VSS, VSSQ, VPP, and VREFCA) must be at valid levels. DRAM internal VREFDQ generator circuitry may remain ON or turned OFF depending on DRAM design. If DRAM internal VREFDQ circuitry is turned OFF in self refresh, when DRAM exits from self refresh state, it ensures that VREFDQ generator circuitry is powered up and stable within tXS period. First Write operation or first Write Leveling Activity may not occur earlier than tXS after exit from Self Refresh. The DRAM initiates a minimum of one Refresh command internally within tCKE period once it enters Self-Refresh mode.

The clock is internally disabled during Self-Refresh Operation to save power. The minimum time that the DDR4 SDRAM must remain in Self-Refresh mode is tCKESR. The user may change the external clock frequency or halt the external clock tCKSRE after Self-Refresh entry is registered, however, the clock must be restarted and stable tCKSRX before the device can exit Self-Refresh operation.

The procedure for exiting Self-Refresh requires a sequence of events. First, the clock must be stable prior to CKE going back HIGH. Once a Self-Refresh Exit command (SRX, combination of CKE going high and Deselect on command bus) is registered, following timing delay must be satisfied:

1. Commands that do not require locked DLL:

tXS - ACT, PRE, PREA, REF, SRE, PDE, WR, WRS4, WRS8, WRA, WRAS4, WRAS8

tXSFast - ZQCL, ZQCS, MRS commands. For MRS command, only DRAM CL and WR/RTP register and DLL Reset in MR0, RTT_NOM register in MR1, CWL and RTT_WR register in MR2 and gear-down mode in MR3, Write and Read Preamble register in MR4, RTT_PARK register in MR5, tCCD_L/tDLLK and VREFDQ Training Value in MR6 are allowed to be accessed provided DRAM is not in per DRAM addressability mode. Access to other DRAM mode registers must satisfy tXS timing.

Note that synchronous ODT for write commands (WR, WRS4, WRS8, WRA, WRAS4 and WRAS8) and dynamic ODT controlled by write command require locked DLL.

2. Commands that require locked DLL:

tXSDLL - RD, RDS4, RDS8, RDA, RDAS4, RDAS8

Depending on the system environment and the amount of time spent in Self-Refresh, ZQ calibration commands may be required to compensate for the voltage and temperature drift as described in “**ZQ Calibration Commands**” on section 9.14. To issue ZQ calibration commands, applicable timing requirements must be satisfied.

CKE must remain HIGH for the entire Self-Refresh exit period tXSDLL for proper operation except for Self-Refresh re-entry. Upon exit from Self-Refresh, the DDR4 SDRAM can be put back into Self-Refresh mode or Power down mode after waiting at least tXS period and issuing one refresh command (refresh period of tRFC). Deselect commands must be registered on each positive clock edge during the Self-Refresh exit interval tXS. Low level of ODT pin must be registered on each positive clock edge during tXSDLL when normal mode (DLL-on) is set. Under DLL-off mode, asynchronous ODT function might be allowed.

The use of Self-Refresh mode introduces the possibility that an internally timed refresh event can be missed when CKE is raised for exit from Self-Refresh mode. Upon exit from Self-Refresh, the DDR4 SDRAM requires a minimum of one extra refresh command before it is put back into Self-Refresh Mode.

The exit timing from self-refresh exit to first valid command not requiring a locked DLL is tXS.

The value of tXS is (tRFC+10nS). This delay is to allow for any refreshes started by the DRAM to complete. tRFC continues to grow with higher density devices so tXS will grow as well.

A Bit A9 in MR4 is defined to enable the self refresh abort mode. If the bit is disabled then the controller uses tXS timings. If the bit is enabled then the DRAM aborts any ongoing refresh and does not increment the refresh counter. The controller can issue a valid command not requiring a locked DLL after a delay of tXS_abort.

Upon exit from Self-Refresh, the DDR4 SDRAM requires a minimum of one extra refresh command before it is put back into Self-Refresh Mode. This requirement remains the same irrespective of the setting of the MRS bit for self refresh abort.

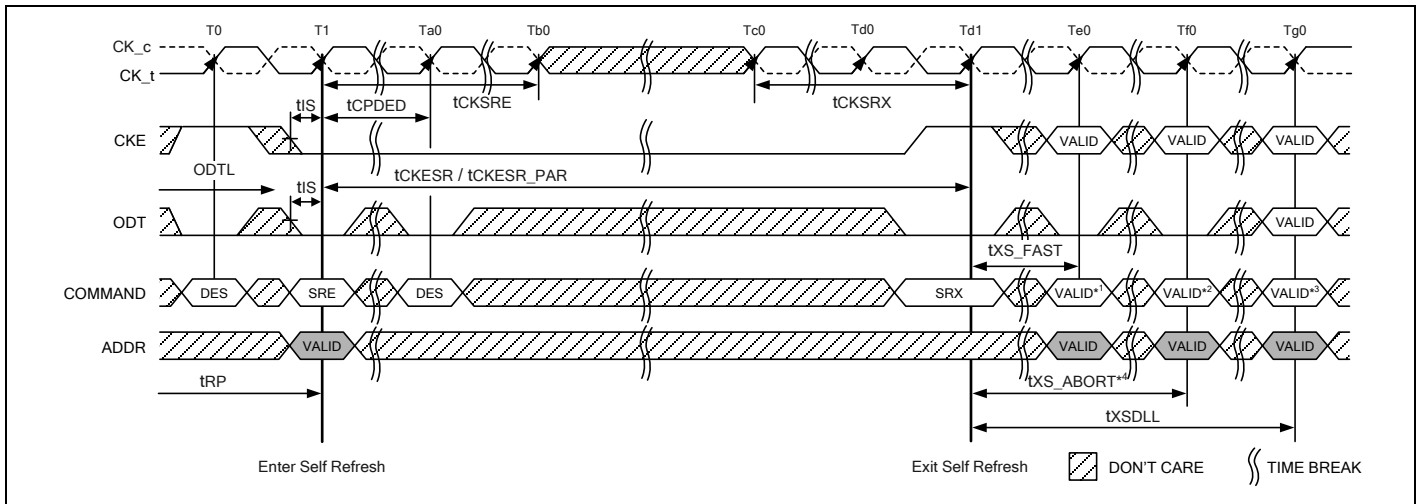

Notes:

1. Only MRS (limited to those described in the Self-Refresh Operation section). ZQCS or ZQCL command allowed.
2. Valid commands not requiring a locked DLL.
3. Valid commands requiring a locked DLL.
4. Only DES is allowed during tXS_ABORT.

Figure 141 – Self-Refresh Entry/Exit Timing

9.29.1 Low Power Auto Self Refresh

DDR4 devices support Low Power Auto Self-Refresh (LP ASR) operation at multiple temperatures ranges (See temperature table below). Mode Register MR2 – descriptions.

Table 48 – MR2 definitions for Low Power Auto Self-Refresh mode

A6	A7	Self-Refresh Operation Mode
0	0	Manual Mode – Normal operating temperature range
0	1	Manual Mode – Extended operating temperature range
1	0	Manual Mode – Lower power mode at a reduced operating temperature range
1	1	ASR Mode – automatically switching between all modes to optimize power for any of the temperature ranges listed above

Auto Self Refresh (ASR)

DDR4 DRAM provides an Auto Self-Refresh mode (ASR) for application ease. ASR mode is enabled by setting the above MR2 bits A6=1 and A7=1. The DRAM will manage Self Refresh entry through the supported temperature range of the DRAM. In this mode, the DRAM will change self-refresh rate as the DRAM operating temperature changes, lower at low temperatures and higher at high temperatures.

Manual Modes

If ASR mode is not enabled, the LP ASR Mode Register must be manually programmed to one the three self-refresh operating modes listed above. In this mode, the user has the flexibility to select a fixed self-refresh operating mode at the entry of the self refresh according to their system memory temperature conditions. The user is responsible to maintain the required memory temperature condition for the mode selected during the self-refresh operation. The user may change the selected mode after exiting from self refresh and before the next self-refresh entry. If the temperature condition is exceeded for the mode selected, there is risk to data retention resulting in loss of data.



Table 49 – Self Refresh Function table

MR2-A6	MR2-A7	LP ASR Mode	Self Refresh Operation	Allowed Operating Temperature Range for Self Refresh Mode (all reference to DRAM Tcase)
0	0	Normal	Variable or fixed normal self-Refresh rate to maintain data retention for the normal operating temperature. User is required to ensure 85°C DRAM Tcasemax is not exceeded to avoid any risk of data loss.	(-40°C – 85°C)
0	1	Extended Temperature range	Variable or fixed high self-Refresh rate to optimize data retention to support the extended temperature range	(-40°C – 105°C)
1	0	Reduced Temperature range	Variable or fixed self-Refresh rate or any other DRAM power consumption reduction control for the reduced temperature range. User is required to ensure 45°C DRAM Tcasemax is not exceeded to avoid any risk of data loss	(-40°C – 45°C)
1	1	Auto Self Refresh	ASR Mode Enabled. Self-Refresh power consumption and data retention are optimized for any given operating temperature conditions	All of the above



9.30 Power Down Mode

9.30.1 Power-Down Entry and Exit

Power-down is synchronously entered when CKE is registered low (along with Deselect command). CKE is not allowed to go low while mode register set command, MPR operations, ZQCAL operations, DLL locking or read / write operation are in progress. CKE is allowed to go low while any of other operations such as row activation, precharge or auto precharge and refresh are in progress, but power-down IDD spec will not be applied until finishing those operations. Timing diagrams are shown in Figure 143 through Figure 151 with details for entry and exit of Power-Down.

The DLL should be in a locked state when power-down is entered for fastest power-down exit timing. DRAM design provides all AC and DC timing and voltage specification as well as proper DLL operation with any CKE intensive operations as long as DRAM controller complies with DRAM specifications.

During Power-Down, if all banks are closed after any in-progress commands are completed, the device will be in precharge Power-Down mode; if any bank is open after in-progress commands are completed, the device will be in active Power-Down mode.

Entering power-down deactivates the input and output buffers, excluding CK_t, CK_c, CKE and RESET_n. In power-down mode, DRAM ODT input buffer deactivation is based on MR5 bit A5. If it is configured to 0b, ODT input buffer remains on and ODT input signal must be at valid logic level. If it is configured to 1b, ODT input buffer is deactivated and DRAM ODT input signal may be floating and DRAM does not provide Rtt_{Nom} termination. Note that DRAM continues to provide Rtt_{Park} termination if it is enabled in DRAM mode register MR5 bit A8:A6. To protect DRAM internal delay on CKE line to block the input signals, multiple Deselect commands are needed during the CKE switch off and cycle(s) after, this timing period are defined as tCPDED. CKE_{low} will result in deactivation of command and address receivers after tCPDED has expired.

Table 50 – Power-Down Entry Definitions

Status of DRAM	DLL	PD Exit	Relevant Parameters
Active (A bank or more Open)	On	Fast	tXP to any valid command
Precharged (All banks Precharged)	On	Fast	tXP to any valid command

Also, the DLL is kept enabled during precharge power-down or active power-down. In power-down mode, CKE low, RESET_n high, and a stable clock signal must be maintained at the inputs of the DDR4 SDRAM, and ODT should be in a valid state, but all other input signals are “Don’t Care.” (If RESET_n goes low during Power-Down, the DRAM will be out of PD mode and into reset state.) CKE low must be maintained until tCKE has been satisfied. Power-down duration is limited by 9 times tREFI of the device.

The power-down state is synchronously exited when CKE is registered high (along with a Deselect command). CKE high must be maintained until tCKE has been satisfied. DRAM ODT input signal must be at valid level when DRAM exits from power-down mode independent of MR5 bit A5 if Rtt_{Nom} is enabled in DRAM mode register. If DRAM Rtt_{Nom} is disabled then ODT input signal may remain floating. A valid, executable command can be applied with power-down exit latency, tXP after CKE goes high. Power-down exit latency is defined in the AC specifications Table.

Active Power Down Entry and Exit timing diagram example is shown in Figure 143. Timing Diagrams for CKE with PD Entry, PD Exit with Read and Read with Auto Precharge, Write, Write with Auto Precharge, Activate, Precharge, Refresh, and MRS are shown in Figure 144 through Figure 151. Additional clarification is shown in Figure 152.

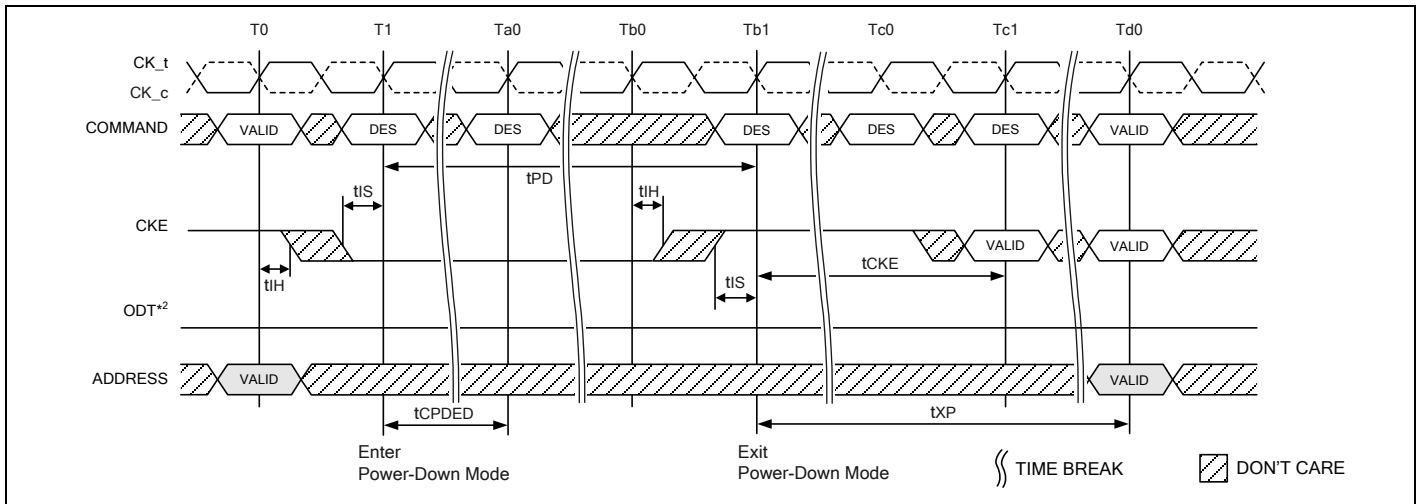

Notes:

1. VALID command at T0 is ACT, DES or Precharge with still one bank remaining open after completion of the precharge command.
2. ODT pin driven to a valid state. MR5 bit A5=0 (default setting) is shown.

Figure 142 – Active Power-Down Entry and Exit Timing Diagram MR5 bit A5 = 0

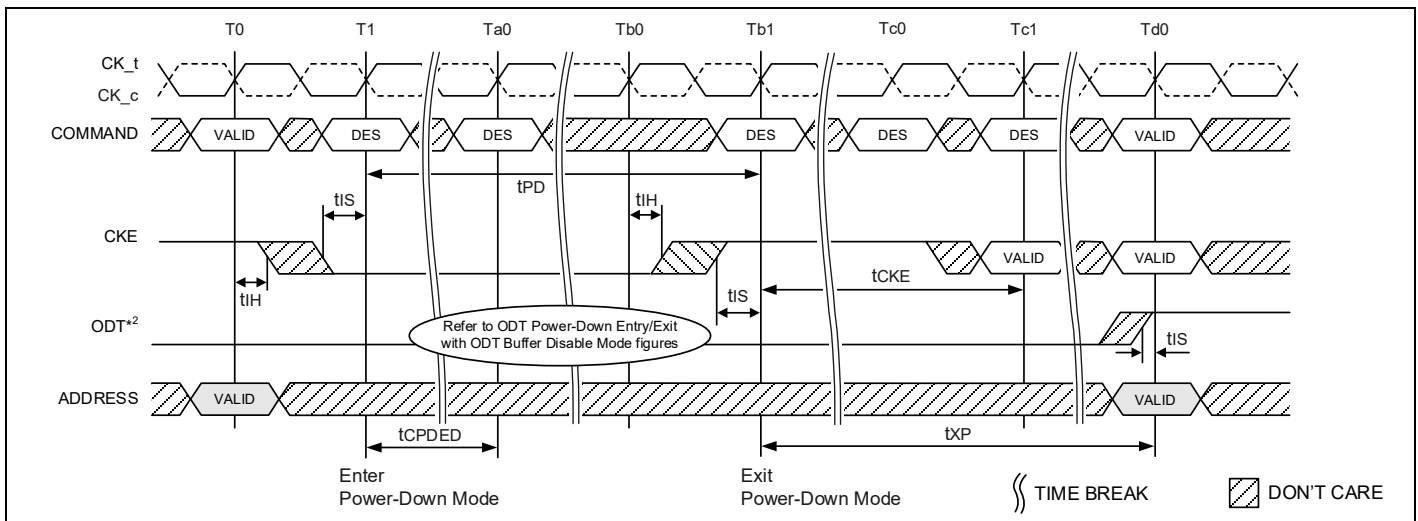

Notes:

1. VALID command at T0 is ACT, DES or Precharge with still one bank remaining open after completion of the precharge command.
2. ODT pin drive/float timing requirements for the ODT input buffer disable option (for additional power savings during active power-down) is described in the section for ODT buffer disabled mode for Power down (page 176); MR5 bit A5 = 1.

Figure 143 – Active Power-Down Entry and Exit Timing Diagram MR5 bit A5 = 1

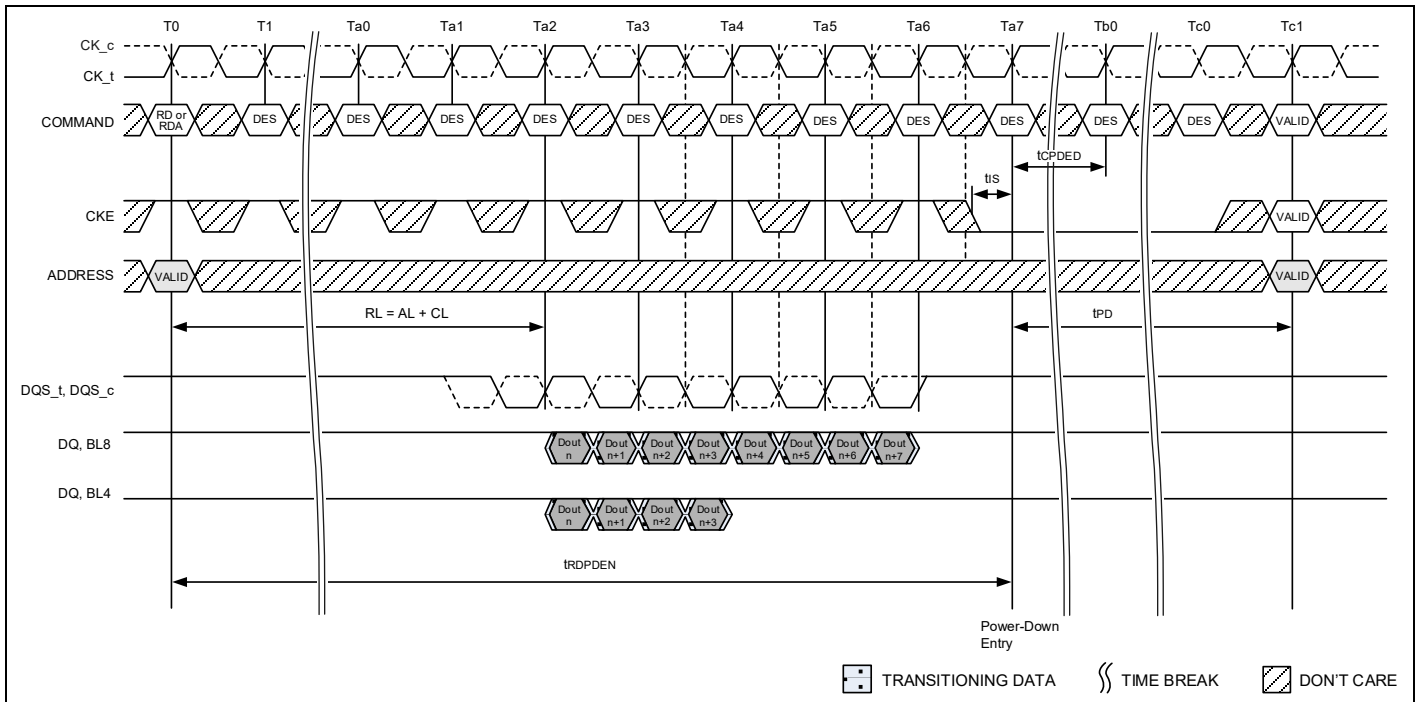

Note:

1. Dout n = data-out from column n.

Figure 144 – Power-Down Entry after Read or Read with Auto Precharge

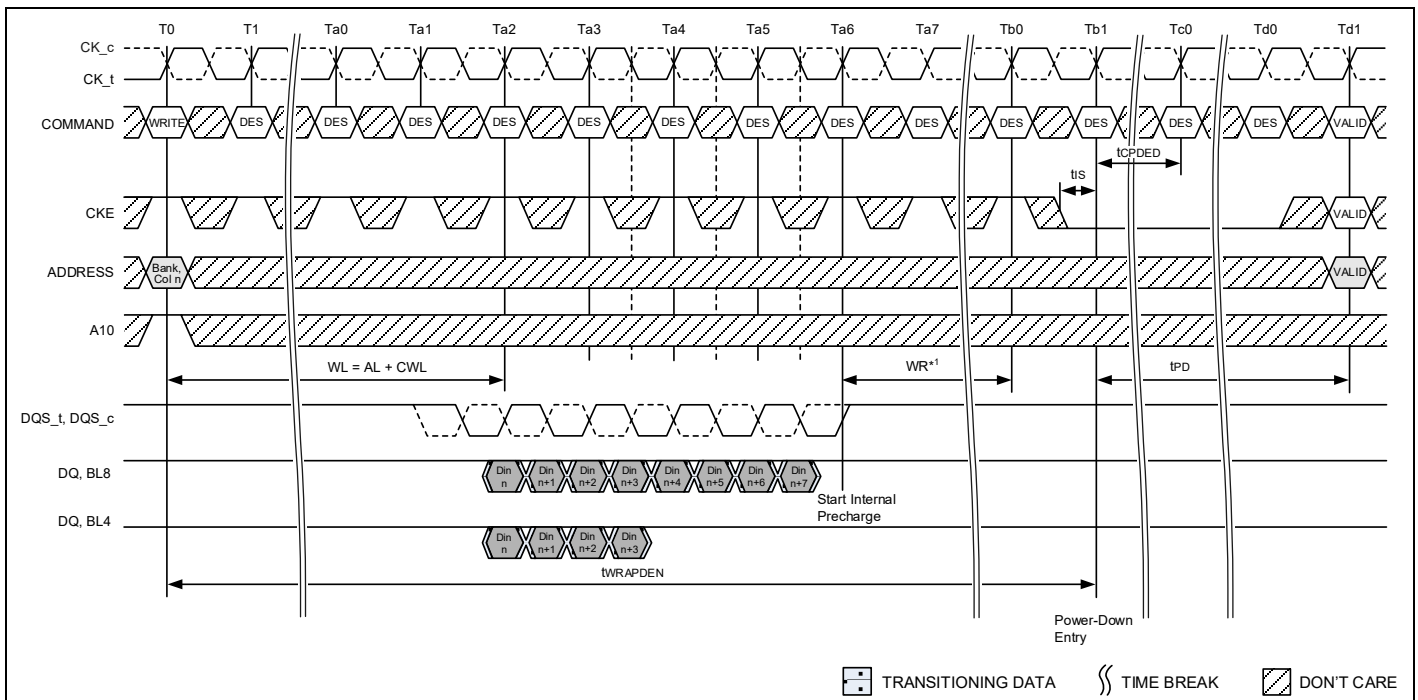

Notes:

1. Din n = data-in to column n.
2. WR is programmed through MR0.

Figure 145 – Power-Down Entry after Write with Auto Precharge

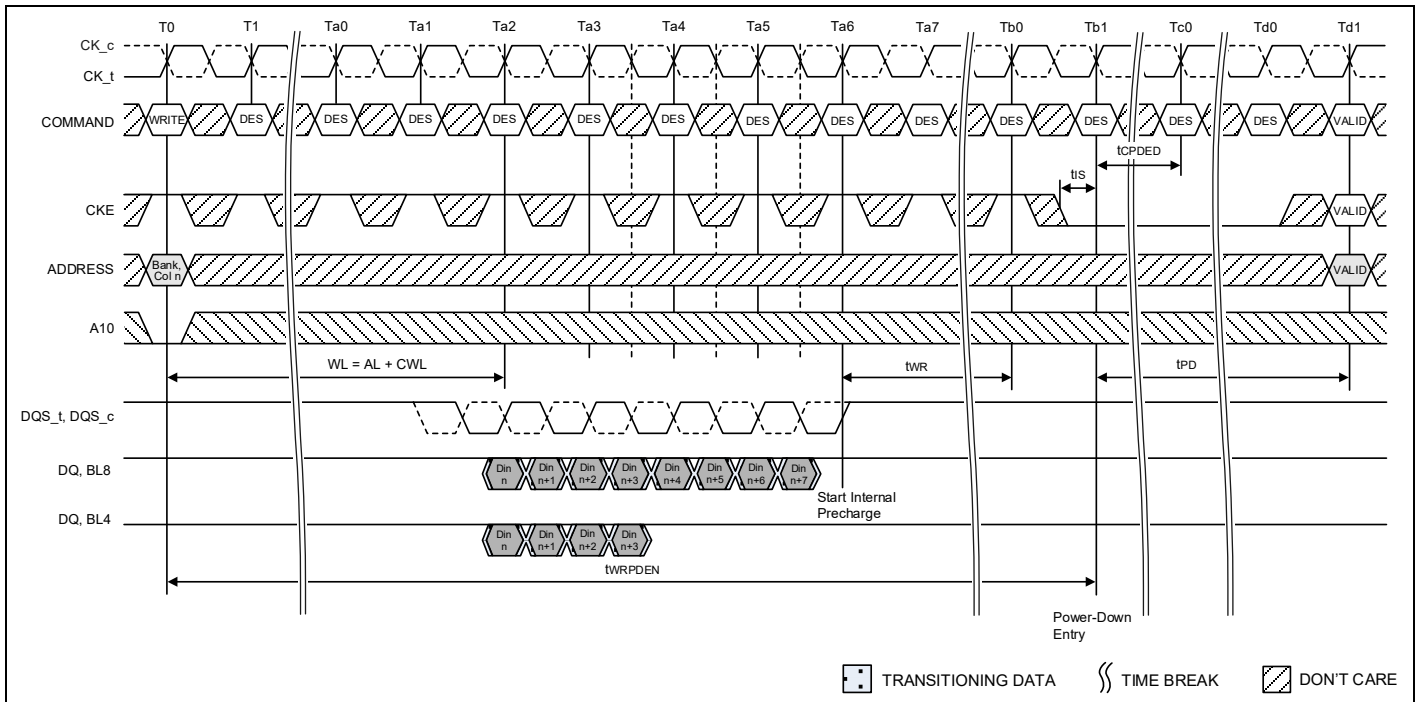

Note:

1. Din n = data-in to column n.

Figure 146 – Power-Down Entry after Write

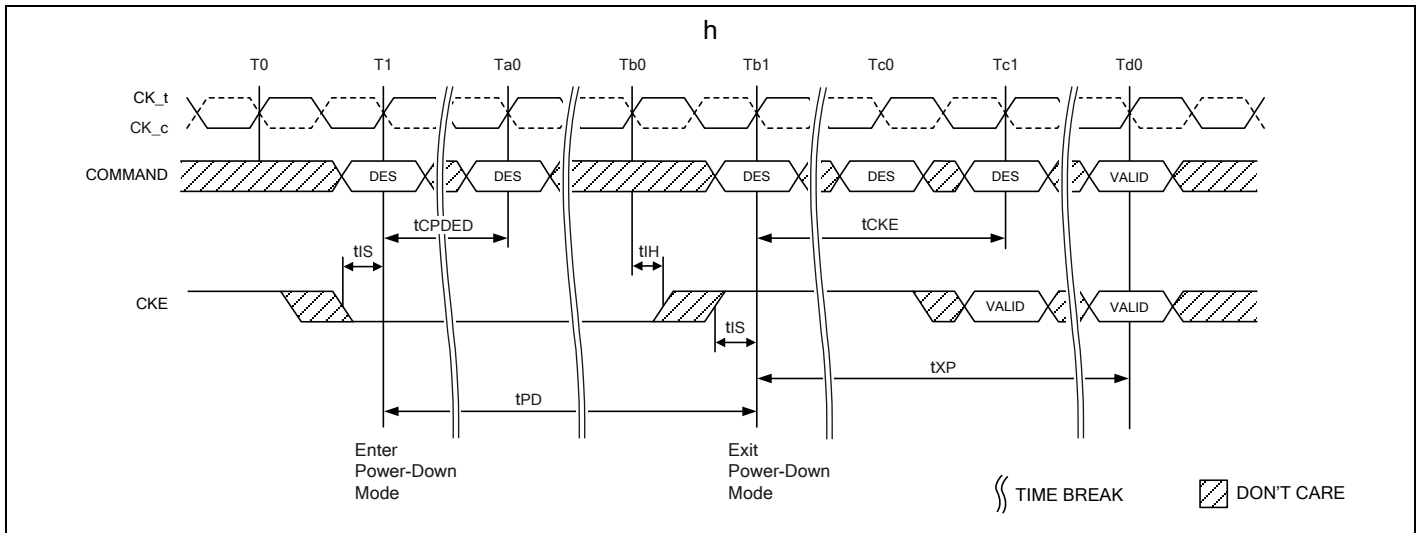

Figure 147 – Precharge Power-Down Entry and Exit

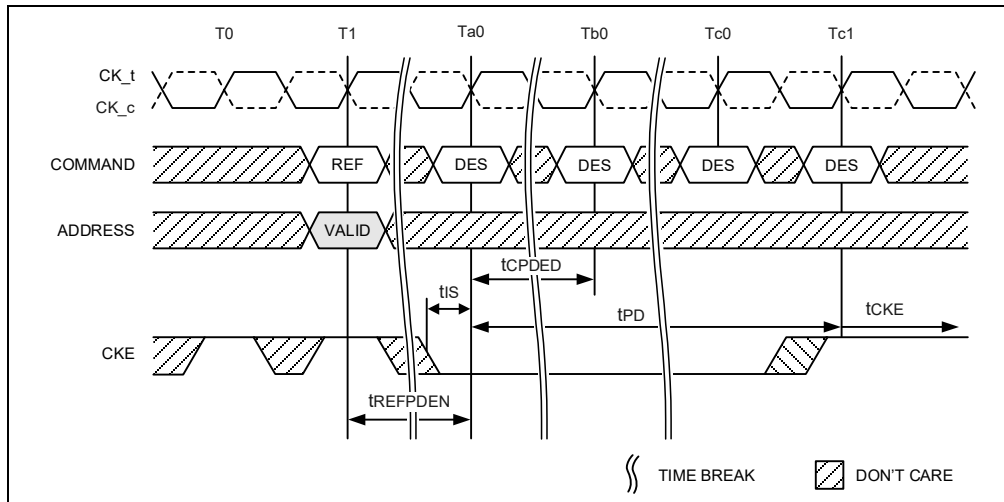

Figure 148 – Refresh Command to Power-Down Entry

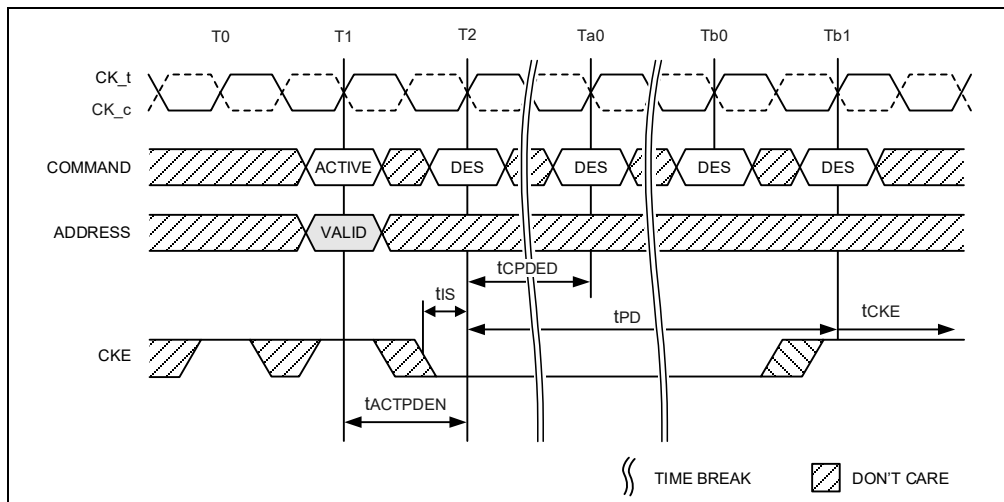

Figure 149 – Activate Command to Power-Down Entry

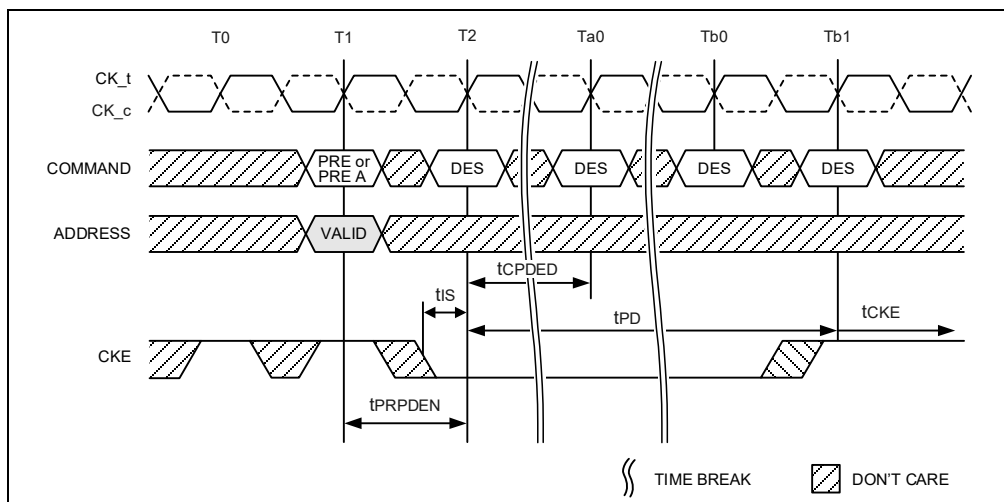

Figure 150 – Precharge/Precharge all Command to Power-Down Entry

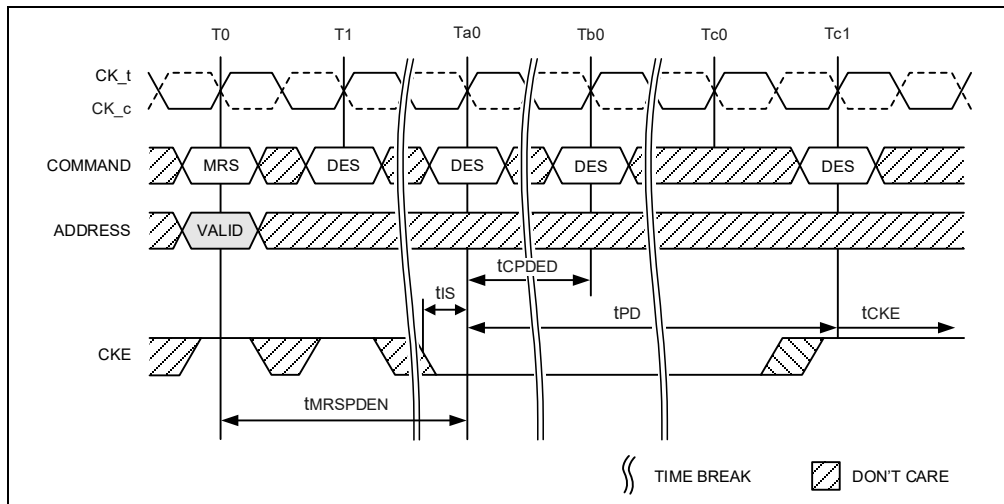

Figure 151 – MRS Command to Power-Down Entry

9.30.2 Power-Down Clarifications

When CKE is registered low for power-down entry, $t_{PD}(\min)$ must be satisfied before CKE can be registered high for power-down exit. The minimum value of parameter $t_{PD}(\min)$ is equal to the minimum value of parameter $t_{CKE}(\min)$ as shown in Table “Timing Parameters by Speed Grade”. A detailed example of Case1 is shown in Figure 152.

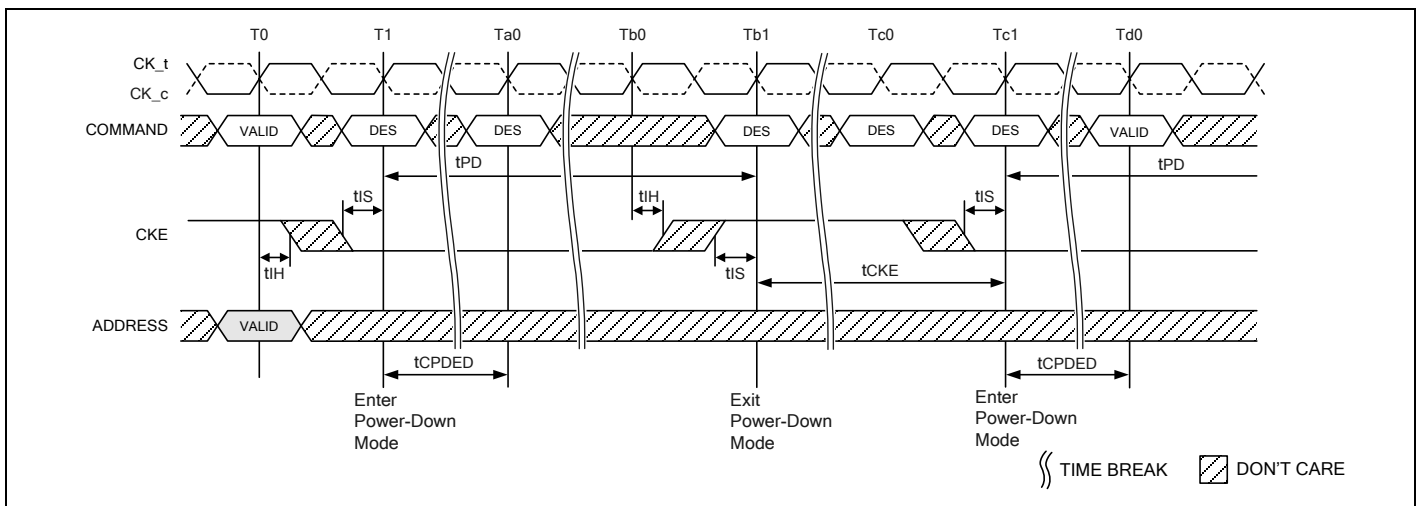
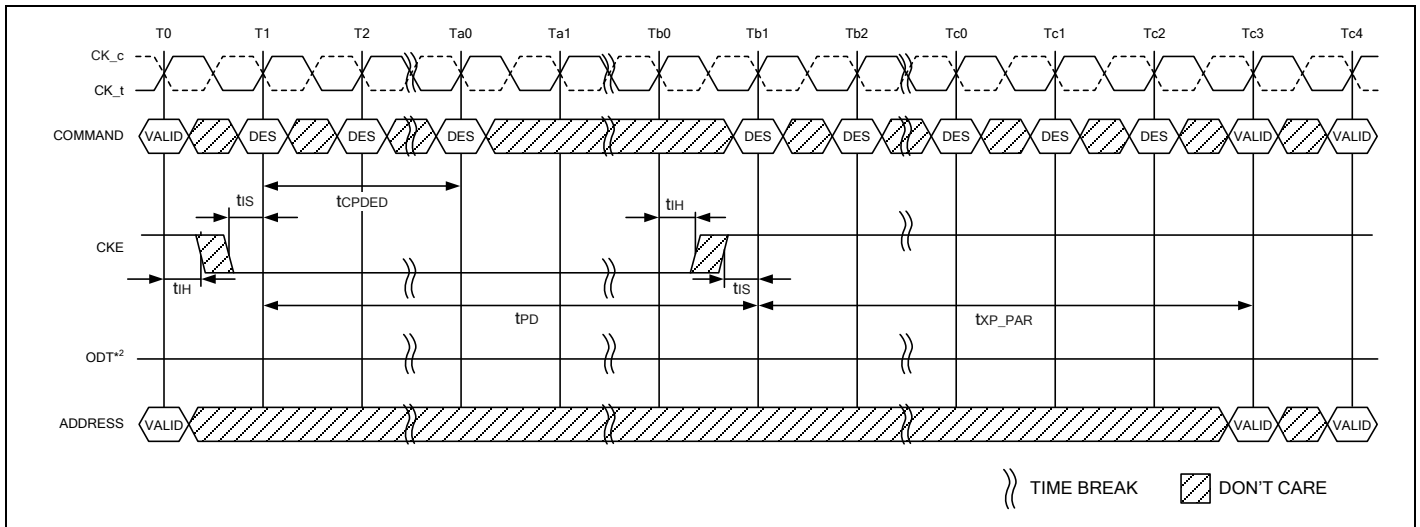

Figure 152 – Power-Down Entry/Exit Clarification



9.30.3 Power Down Entry and Exit timing during Command/Address Parity Mode is Enable

Power Down entry and exit timing during Command/Address parity mode is Enable are shown in Figure 153.



Notes:

1. VALID command at T0 is ACT, DES or Precharge with still one bank remaining open after completion of the precharge command.
2. ODT pin driven to a valid state. MR5 A[5] = 0 (default setting) is shown.
3. CA Parity = Enable

Figure 153 – Power Down Entry and Exit Timing with CA Parity

Table 51 – AC Timing Table

Speed		DDR4-1600,1866,2133,2400,2666,3200		Unit
Parameter	Symbol	MIN	MAX	
Exit Power Down with DLL on to any valid command; Exit Precharge Power Down with DLL frozen to commands not requiring a locked DLL when CA Parity is enabled	tXP_PAR	Max (4nCK,6nS) + PL	-	

9.31 Connectivity Test Mode

9.31.1 Introduction

The DDR4 memory device supports a connectivity test (CT) mode, which is designed to greatly speed up testing of electrical continuity of pin interconnection on the PC boards between the DDR4 memory devices and the memory controller on the SoC. Designed to work seamlessly with any boundary scan devices.

Contrary to other conventional shift register based test mode, where test patterns are shifted in and out of the memory devices serially in each clock, DDR4's CT mode allows test patterns to be entered in parallel into the test input pins and the test results extracted from the test output pins of the DDR4 memory device at the same time, significantly enhancing the speed of the connectivity check. RESET_n is registered to High and VREFCA must be stable prior to entering CT mode. Once put in the CT mode, the DDR4 memory device effectively appears as an asynchronous device to the external controlling agent; after the input test pattern is applied, the connectivity check test results are available for extraction in parallel at the test output pins after a fixed propagation delay. During CT mode, any ODT is turned off.

A reset of the DDR4 memory device is required after exiting the CT mode.



9.31.2 Pin Mapping in Connectivity Test (CT) Mode

Only digital pins can be tested via the CT mode. For the purpose of connectivity check, all pins that are used for the digital logic in the DDR4 memory device are classified as one of the following types:

1. Test Enable (TEN) pin: when asserted high, this pin causes the DDR4 memory device to enter the CT mode. In this mode, the normal memory function inside the DDR4 memory device is bypassed and the IO pins appear as a set of test input and output pins to the external controlling agent; additionally, the DRAM will set the internal VREFDQ to $VDDQ \cdot 0.5$ during CT mode (this is the only time the DRAM takes direct control over setting the internal VREFDQ). The TEN pin is dedicated to the connectivity check function and will not be used during normal memory operation.
2. Chip Select (CS_n) pin: when asserted low, this pin enables the test output pins in the DDR4 memory device. When de-asserted, the output pins in the DDR4 memory device will be tri-stated. The CS_n pin in the DDR4 memory device serves as the CS_n pin when in CT mode.
3. Test Input: a group of pins that are used during normal DDR4 DRAM operation are designated test input pins. These pins are used to enter the test pattern in CT mode.
4. Test Output: a group of pins that are used during normal DDR4 DRAM operation are designated test output pins. These pins are used for extraction of the connectivity test results in CT mode.
5. RESET_n: Fixed high level is required during CT mode same as normal function.

Table 52 below shows the pin classification of the DDR4 memory device.

Table 52 – Pin Classification of DDR4 Memory Device in Connectivity Test (CT) Mode

Pin Type in CT Mode		Pin Names during Normal Memory Operation
Test Enable		TEN
Chip Select		CS _n
Test Input	A	BA0-1, BG0, A0-A9, A10/AP, A12/BC _n , A13, WE _n /A14, CAS _n /A15, RAS _n /A16, CKE, ACT _n , ODT, CK _t , CK _c , PAR
	B	DML _n /DBIL _n , DMU _n /DBIU _n
	C	ALERT _n
	D	RESET _n
Test Output		DQ0 – DQ15, DQSU _t , DQSU _c , DQSL _t , DQSL _c

Table 53 – Signal Description

Symbol	Type	Function
TEN	Input	Connectivity Test Mode is active when TEN is HIGH and inactive when TEN is LOW. TEN must be LOW during normal operation. TEN is a CMOS rail-to-rail signal with DC high and low at 80% and 20% of VDD, i.e, 960mV for DC high and 240mV for DC low.

Table 54 – TEN Pin Weak Pull Down Strength Range

Symbol	Description	Min	Max	Unit
TEN	TEN pin should be internally pulled low to prevent DDR4 SDRAM from conducting Connectivity Test mode in case that TEN is not used.	0.05	10	μA

Note:

1. The host controller should use good enough strength when activating Connectivity Test mode to avoid current fighting at TEN signal and inability of Connectivity Test mode.



9.31.3 Logic Equations

9.31.3.1 Min Term Equations

MTx is an internal signal to be used to generate the signal to drive the output signals.

$MT0 = \text{XOR}(A1, A6, \text{PAR})$
 $MT1 = \text{XOR}(A8, \text{ALERT}, A9)$
 $MT2 = \text{XOR}(A2, A5, A13)$
 $MT3 = \text{XOR}(A0, A7, A11)$
 $MT4 = \text{XOR}(\text{CK}_c, \text{ODT}, \text{CAS}_n/A15)$
 $MT5 = \text{XOR}(\text{CKE}, \text{RAS}_n/A16, A10/AP)$
 $MT6 = \text{XOR}(\text{ACT}_n, A4, \text{BA}1)$
 $MT7 = \text{XOR}(\text{DMU}_n / \text{DBIU}_n, \text{DML}_n / \text{DBIL}_n, \text{CK}_t)$
 $MT8 = \text{XOR}(\text{WE}_n / A14, A12 / \text{BC}, \text{BA}0)$
 $MT9 = \text{XOR}(\text{BG}0, A3, (\text{Reset}_n \text{ and } \text{TEN}))$

9.31.3.2 Output equations for x16 devices

$DQ0 = MT0$
 $DQ1 = MT1$
 $DQ2 = MT2$
 $DQ3 = MT3$
 $DQ4 = MT4$
 $DQ5 = MT5$
 $DQ6 = MT6$
 $DQ7 = MT7$
 $DQ8 = !DQ0$
 $DQ9 = !DQ1$
 $DQ10 = !DQ2$
 $DQ11 = !DQ3$
 $DQ12 = !DQ4$
 $DQ13 = !DQ5$
 $DQ14 = !DQ6$
 $DQ15 = !DQ7$
 $DQSL_t = MT8$
 $DQSL_c = MT9$
 $DQSU_t = !DQSL_t$
 $DQSU_c = !DQSL_c$



9.31.4 Input level and Timing Requirement for Connectivity Test (CT) Mode

During CT Mode, input levels are defined below.

TEN pin: CMOS rail-to-rail with DC high and low at 80% and 20% of VDD.

CS_n: Pseudo differential signal referring to VREFCA

Test Input pin A: Pseudo differential signal referring to VREFCA

Test Input pin B: Pseudo differential signal referring to internal Vref 0.5*VDD

RESET_n: CMOS DC high above 70 % VDD

ALERT_n: CMOS rail-to-rail with DC high and low at 80% and 20% of VDD.

Prior to the assertion of the TEN pin, all voltage supplies must be valid and stable.

Upon the assertion of the TEN pin, the CK_t and CK_c signals will be ignored and the DDR4 memory device enter into the CT mode after tCT_Enable. In the CT mode, no refresh activities in the memory arrays, initiated either externally (i.e., auto-refresh) or internally (i.e., self-refresh), will be maintained.

The TEN pin may be asserted after the DRAM has completed power-on; once the DRAM is initialized and VREFDQ is calibrated, CT Mode may no longer be used.

The TEN pin may be de-asserted at any time in the CT mode. Upon exiting the CT mode, the states of the DDR4 memory device are unknown and the integrity of the original content of the memory array is not guaranteed and therefore the reset initialization sequence is required.

All output signals at the test output pins will be stable within tCT_Valid after the test inputs have been applied to the test input pins with TEN input and CS_n input maintained High and Low respectively.

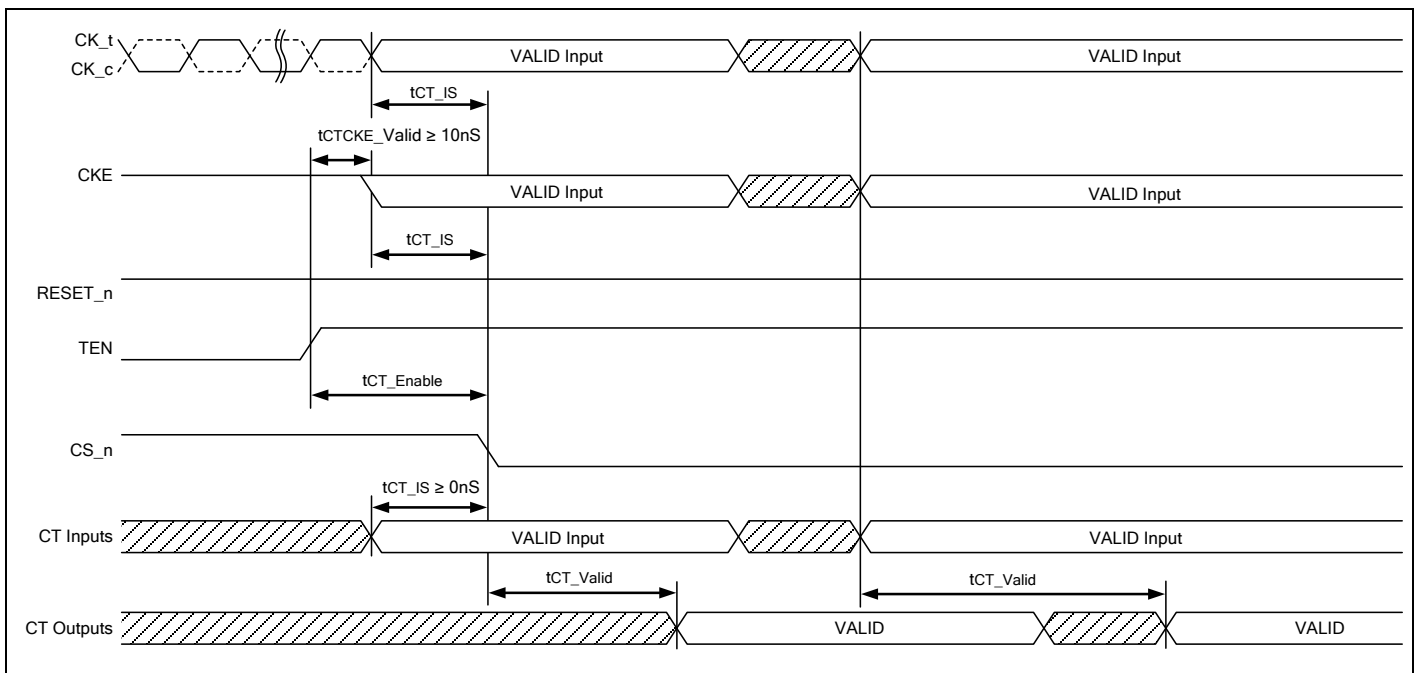

Figure 154 – Timing Diagram for Connectivity Test (CT) Mode

Table 55 – AC parameters for Connectivity Test (CT) Mode

Symbol	Min	Max	Unit
tCT_IS	0		nS
tCT_Enable	200	-	nS
tCT_Valid	-	200	nS



9.31.5 Connectivity Test (CT) Mode Input Levels

Following input parameters will be applied for DDR4 SDRAM Input Signal during Connectivity Test Mode.

Table 56 – CMOS rail to rail Input Levels for TEN

Parameter	Symbol	Min	Max	Unit	Notes
TEN AC Input High Voltage	VIH(AC)_TEN	0.8 * VDD	VDD	V	1
TEN DC Input High Voltage	VIH(DC)_TEN	0.7 * VDD	VDD	V	
TEN DC Input Low Voltage	VIL(DC)_TEN-	VSS	0.3 * VDD	V	
TEN AC Input Low Voltage	VIL(AC)_TEN	VSS	0.2 * VDD	V	2
TEN Input signal Falling time	TF_input_TEN	-	10	nS	
TEN Input signal Rising time	TR_input_TEN	-	10	nS	

Notes:

1. Overshoot might occur. It should be limited by the Absolute Maximum DC Ratings.
2. Undershoot might occur. It should be limited by Absolute Maximum DC Ratings.

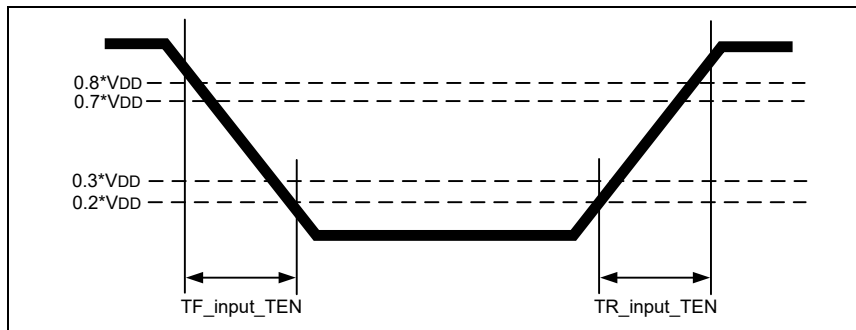

Figure 155 – TEN Input Slew Rate Definition

Table 57 – Single-Ended AC and DC Input levels for CS_n, BA0-1, BG0, A0-A9, A10/AP, A12/BC_n, A13, WE_n/A14, CAS_n/A15, RAS_n/A16, CKE, ACT_n, ODT, CK_t, CK_c, and PAR

Parameter	Symbol	Min	Max	Unit	Notes
CTipA AC Input High Voltage	VIH(AC)_CTipA	VREFCA + 0.2	Note 1	V	
CTipA DC Input High Voltage	VIH(DC)_CTipA	VREFCA + 0.15	VDD	V	
CTipA DC Input Low Voltage	VIL(DC)_CTipA	VSS	VREFCA - 0.15	V	
CTipA AC Input Low Voltage	VIL(AC)_CTipA	Note 1	VREFCA - 0.2	V	
CTipA Input signal Falling time	TF_input_CTipA	-	5	nS	
CTipA Input signal Rising time	TR_input_CTipA	-	5	nS	

Note:

1. See 12.3.4 and 12.3.5 "Overshoot and Undershoot Specifications".

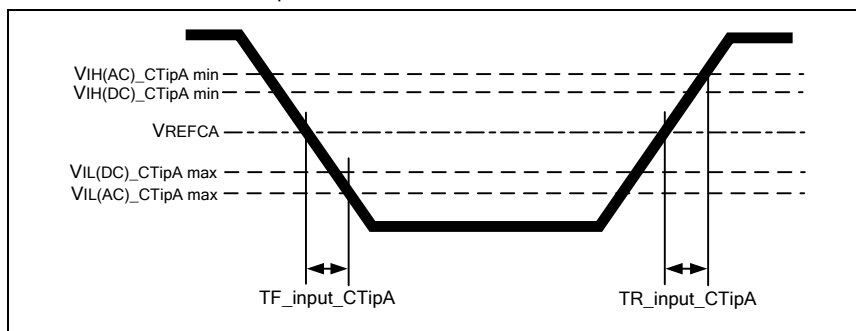

Figure 156 – CS_n and Input A Slew Rate Definition



Table 58 – Single-Ended AC and DC Input levels for DML_n/DBIL_n and DMU_n/DBIU_n

Parameter	Symbol	Min	Max	Unit	Notes
CTipB AC Input High Voltage	VIH(AC)_CTipB	VREFDQ + 0.3	Note 2	V	1
CTipB DC Input High Voltage	VIH(DC)_CTipB	VREFDQ + 0.2	VDDQ	V	1
CTipB DC Input Low Voltage	VIL(DC)_CTipB	VSSQ	VREFDQ - 0.2	V	1
CTipB AC Input Low Voltage	VIL(AC)_CTipB	Note 2	VREFDQ - 0.3	V	1
CTipB Input signal Falling time	TF_input_CTIPB	-	5	nS	
CTipB Input signal Rising time	TR_input_CTIPB	-	5	nS	

Notes:

1. VREFDQ is VDDQ*0.5.
2. See 12.3.6 "Overshoot and Undershoot Specifications".

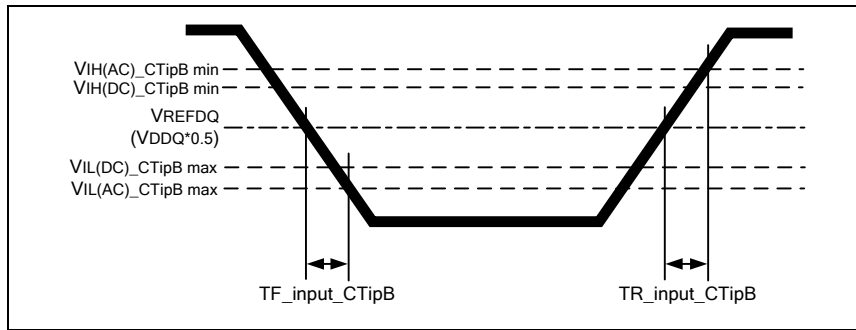

Figure 157 – Input B Slew Rate Definition

9.31.5.1 Input Levels for RESET_n

RESET_n input condition is the same as normal operation.

9.31.5.2 Input Levels for ALERT_n

Table of Input levels for ALERT_n

Parameter	Symbol	Min	Max	Unit	Notes
CTipC AC Input High Voltage	VIH(AC)_CTipC	0.8 * VDD	VDD	V	1
CTipC DC Input High Voltage	VIH(DC)_CTipC	0.7 * VDD	VDD	V	
CTipC DC Input Low Voltage	VIL(DC)_CTipC	VSS	0.3 * VDD	V	
CTipC AC Input Low Voltage	VIL(AC)_CTipC	VSS	0.2 * VDD	V	2
CTipC Input signal Falling time	TF_input_CTIPC	-	10	nS	
CTipC Input signal Rising time	TR_input_CTIPC	-	10	nS	

Notes:

1. Overshoot might occur. It should be limited by the Absolute Maximum DC Ratings.
2. Undershoot might occur. It should be limited by Absolute Maximum DC Ratings.

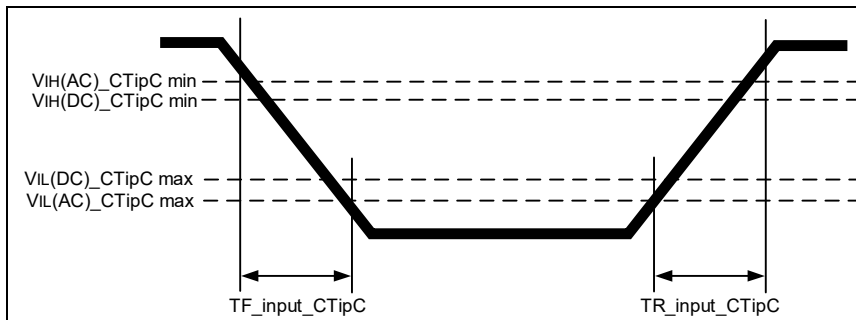

Figure of Input C Slew Rate Definition



9.32 Post Package Repair (hPPR)

DDR4 supports Fail Row address repair feature. PPR provides simple and easy repair method in the system and Fail Row address can be repaired by the electrical programming of Electrical-fuse scheme.

With hPPR, DDR4 can correct 1 Row per Bank.

Electrical-fuse cannot be switched back to un-fused states once it is programmed. The controller should prevent unintended hPPR mode entry and repair. (i.e. Command/Address training period)

DDR4 defines two hard fail row address repair sequences and users can choose to use among those 2 command sequences. The first command sequence uses a WRA command and ensures data retention with Refresh operations except for the 2 banks containing the rows being repaired, with BA[0] a don't care. Second command sequence is to use WR command and Refresh operation can't be performed in the sequence. So, the second command sequence doesn't ensure data retention for target DRAM.

When hard PPR Mode is supported, entry into hPPR Mode is to be is protected through a sequential MRS guard key to prevent unintentional hPPR programming. When soft PPR Mode, i.e. sPPR, is supported, entry into sPPR Mode is to be protected through a sequential MRS guard key to prevent unintentional sPPR programming. The sequential MRS guard key for hPPR mode and sPPR is the same Guard Key, i.e., hPPR/sPPR Guard Key.

The hPPR/sPPR Guard Key requires a sequence of four MR0 commands to be executed immediately after entering hPPR mode (setting MR4 bit 13 to a "1") or immediately after entering sPPR mode (setting MR4 bit 5 to a "1"). The hPPR/sPPR Guard Key's sequence must be entered in the specified order as stated and shown in the spec below. Any interruption of the hPPR/sPPR Guard Key sequence from other MR commands or non-MR commands such as ACT, WR, RD, PRE, REF, ZQ, NOP, RFU is not allowed. Although interruption of the hPPR/sPPR Guard Key entry is not allowed, if the hPPR/sPPR Guard Key is not entering in the required order or is interrupted by other commands, the hPPR Mode or sPPR Mode will not execute and the offending command terminating hPPR/sPPR Mode may or may not execute correctly; however, the offending command will not cause the DRAM to "lock up". Additionally, when the hPPR or sPPR entry sequence is interrupted, subsequent ACT and WR commands will be conducted as normal DRAM commands. If a hPPR operation was prematurely terminated, the MR4 bit 13 must be re-set "0" prior to performing another hPPR or sPPR operation. If a sPPR operation was prematurely terminated, the MR4 bit 5 must be re-set to "0" prior to performing another sPPR or hPPR operation. The DRAM does not provide an error indication if an incorrect hPPR/sPPR Guard Key sequence is entered.

Table 59 – hPPR and sPPR MR0 Guard Key Sequences

Guard Keys	BG0	BA1:0	A16:A12	A11	A10	A9	A8	A7	A6:A0
1 st MR0	00	00	X	1	1	0	0	1	Don't Care
2 nd MR0	00	00	X	0	1	1	1	1	Don't Care
3 rd MR0	00	00	X	1	0	1	1	1	Don't Care
4 th MR0	00	00	X	0	0	1	1	1	Don't Care

Notes:

1. A6:A0 are 'Don't Care'.
2. After completing hPPR and sPPR mode, MR0 must be re-programmed to pre-PPR mode state if the DRAM is to be accessed.



9.32.1 Hard Fail Row Address Repair (WRA Case)

The following is procedure of hPPR with WRA command.

1. Before entering "hPPR" mode, all banks must be precharged; DBI and CRC Modes must be disabled.
2. Enable hPPR using MR4 bit "A13 = 1" and wait tMOD.
3. Issue guard Key as four consecutive MR0 commands each with a unique address field A[16:0]. Each MR0 command should space by tMOD.
4. Issue ACT command with Fail Row address.
5. After tRCD, Issue WRA with VALID address. DRAM will consider valid address with WRA command as 'Don't Care'.
6. After WL ($WL=CWL+AL+PL$), All DQs of Target DRAM should be LOW for 4tCK. If HIGH is driven to All DQs of a DRAM consecutively for equal to or longer than 2tCK, then DRAM does not conduct hPPR and retains data if REF command is properly issued; if all DQs are neither LOW for 4tCK nor HIGH for equal to or longer than 2tCK, then hPPR mode not execution.
7. Wait tPGM to allow DRAM repair target Row Address internally and issue PRE.
8. Wait tPGM_Exit after PRE which allow DRAM to recognize repaired Row address.
9. Exit hPPR with setting MR4 bit "A13 = 0".
10. DDR4 will accept any valid command after tPGMPST.
11. In more than one fail address repair case, Repeat Step 2 to 9.

In addition to that, hPPR mode allows REF commands from $PL+WL+BL/2+tWR+tRP$ after WRA command during tPGM and tPGMPST for proper repair; provided multiple REF commands are issued at a rate of tREFI or tREFI/2, however back-to-back REF commands must be separated by at least tREFI/4 when the DRAM is in hPPR mode. Upon receiving REF command, DRAM performs normal Refresh operation and ensure data retention with Refresh operations except for the 2banks containing the rows being repaired, with BA[0] don't care. Other command except REF during tPGM can cause incomplete repair so no other command except REF is allowed during tPGM.

Once hPPR mode is exited, to confirm if target row is repaired correctly, host can verify by writing data into the target row and reading it back after hPPR exit with MR4 A[13] = 0 and tPGMPST.



9.32.2 Hard Fail Row Address Repair (WR Case)

The following is procedure of hPPR with WR command.

1. Before entering hPPR mode, all banks must be precharged; DBI and CRC modes must be disabled.
2. Enable hPPR using MR4 bit "A13 = 1" and wait tMOD.
3. Issue guard Key as four consecutive MR0 commands each with a unique address field A[16:0]. Each MR0 command should space by tMOD.
4. Issue ACT command with row address.
5. After tRCD, issue WR with valid address. DRAM consider the valid address with WR command as 'Don't Care'.
6. After WL (WL=CWL+AL+PL), All DQs of target DRAM should be LOW for 4tCK. If HIGH is driven to All DQs of a DRAM consecutively for equal to or longer than first 2 tCK, then DRAM does not conduct hPPR and retains data if REF command is properly issued; if all DQs are neither LOW for 4 tCK nor HIGH for equal to or longer than first 2tCK, then hPPR mode execution is unknown.
7. Wait tPGM to allow DRAM repair target Row Address internally and issue PRE.
8. Wait tPGM_Exit after PRE which allow DRAM to recognize repaired Row address.
9. Exit hPPR with setting MR4 bit "A13=0".
10. DDR4 will accept any valid command after tPGMPST.
11. In more than one fail address repair case, Repeat Step 2 to10.

In this sequence, Refresh command is not allowed between hPPR MRS entry and exit.

Once hPPR mode is exited, to confirm if target row is repaired correctly, host can verify by writing data into the target row and reading it back after hPPR exit with MR4 A[13] = 0 and tPGMPST.

9.32.3 Hard Fail Row Address Repair MR bits and timing diagram

Table 60, Figure 158, and Figure 159 show hPPR related MR bits and its operation.

Table 60 – hPPR Setting

MR4 A[13]	Description
0	hPPR Disabled
1	hPPR Enabled

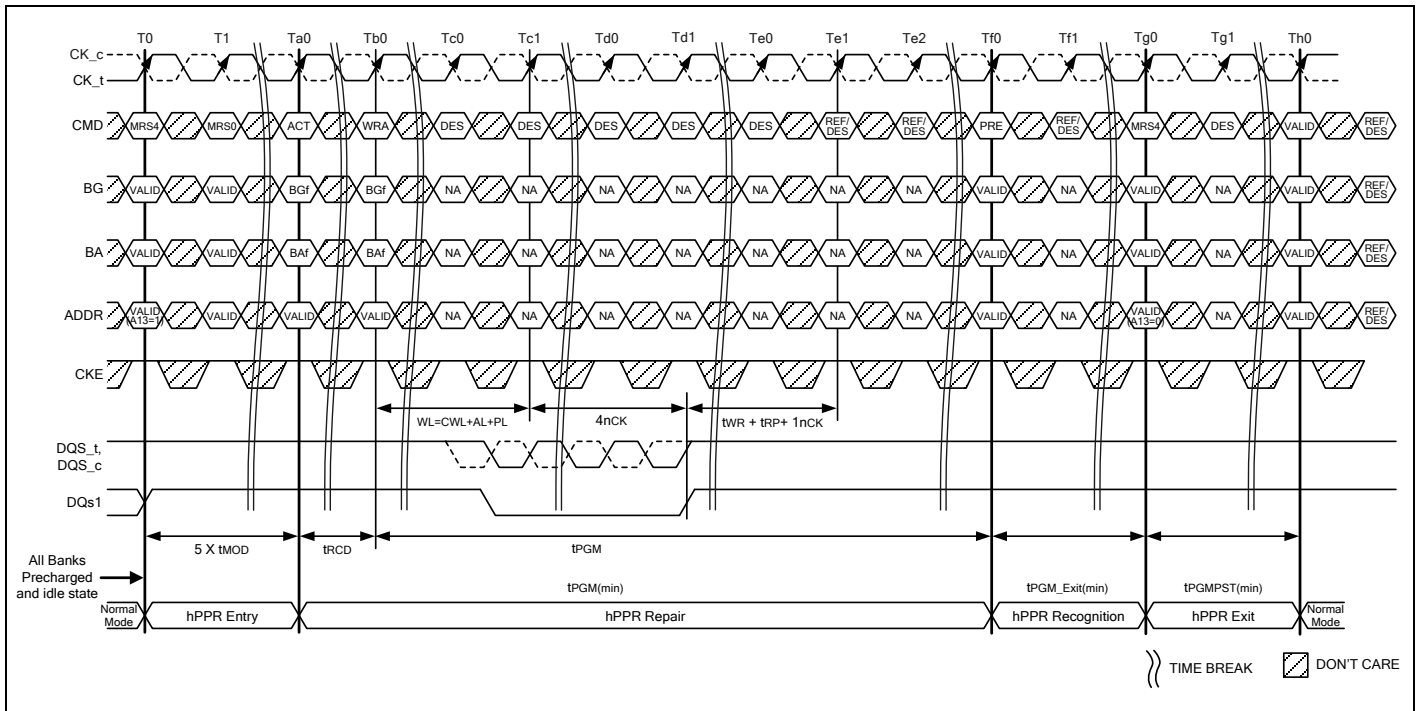

Notes:

1. Allow REF(1X) from $PL + WL + BL/2 + tWR + tRP$ after WR.
2. Timing diagram shows possible commands but not all shown can be issued at same time; for example if REF is issued at Te1, DES must be issued at Te2 as REF would be illegal at Te2. Likewise, DES must be issued tRFC prior to PRE at Tf0. All regular timings must still be satisfied.

Figure 158 – Hard Fail Row Repair (WRA Case)

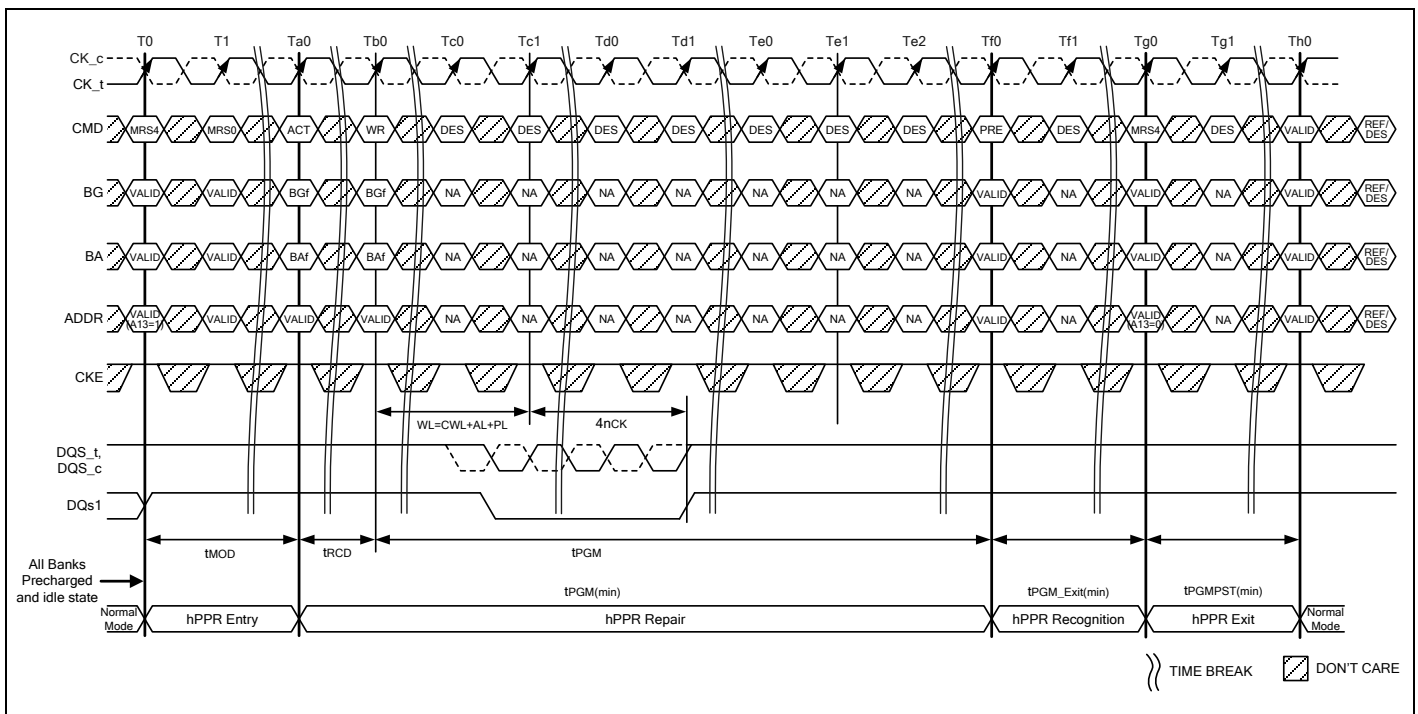

Figure 159 – Hard Fail Row Repair (WR Case)



9.32.4 Programming hPPR and sPPR support in MPR0 page2

hPPR and sPPR is a feature of DDR4 4Gb so Host can recognize if DRAM is supporting hPPR and sPPR or not by reading out MPR0 Page2.

MPR page2;

hard PPR is supported: [7]=1

hard PPR is not supported: [7]=0

soft PPR is supported: [6]=1

soft PPR is not supported: [6]=0

9.32.5 Required Timing Parameters for hPPR

Repair requires additional time period to repair Hard Fail Row Address into spare Row address and the followings are requirement timing parameters for hPPR.

Table 61 – hPPR Timing Parameters

Parameter	Symbol	DDR4-1600/1866/2133/2400		DDR4-2666/3200		Unit	Note
		min	max	min	max		
hPPR Programming Time (x16)	tPGMb	2,000	-	2,000	-	mS	
hPPR Exit Time	tPGM_Exit	15	-	15	-	nS	
New Address Setting time	tPGMPST	50	-	50	-	μS	

9.33 Soft Post Package Repair (sPPR)

Soft Post Package Repair (sPPR) is a way to quickly, but temporarily, repairs a row element in a Bank on a DDR4 DRAM device, contrasted to hard Post Package Repair which takes longer but is permanent repair of a row element. There are some limitations and differences between sPPR and hPPR.

Table 62 – Description and Comparison of hPPR and sPPR

Topic	Soft Repair	Hard Repair	Note
Persistence of Repair	Volatile – repair persists while power is within operating range	Non-Volatile – repair is permanent after the repair cycle	sPPR cleared after power off or device reset
tPGM (hPPR and sPPR programming Time)	WL + 4tCK + tWR	> 2000mS (tPGMb)	
# of Repair elements	1 Row per Bank	1 Row per Bank	Once hPPR is used within a BG, sPPR is no longer supported in that BG
Simultaneous use of soft and hard repair within a BG	Previous hPPR are allowed before soft repair to a different BG	Any outstanding sPPR must be cleared before a hard repair	Clearing sPPR occurs by either: (a) power down and power-up sequence or (b) Reset and re-initialize.
Repair Sequence	1 method – WR command	2 methods WRA and WR	
Bank*1 not having row repair retains array data	Yes	Yes, if WRA sequence; No, if WR sequence	WRA sequence requires use of REF commands
Bank*1 having row repair retain array data	Yes, except for seed and associated rows	No	sPPR must be performed outside of REF window (trFC)

Note:

1. If a BA pin is defined to be a "sPPR associated row" to the seed row, both states of the BA address input are affected. For example if BA0 is selected as a "sPPR associated row" to the seed row, addresses in both BA0 = 0 and BA0 = 1 are equally affected.



sPPR mode is entered in a similar fashion as hPPR, sPPR uses MR4 bit A5 while hPPR uses MR4 bit A13; sPPR requires the same guard key sequence as hPPR to qualify the MR4 PPR entry. Prior to sPPR entry, either a hPPR exit command or a sPPR exit command should be performed, whichever was the last PPR entry. After sPPR entry, an ACT command will capture the target bank and target row, herein seed row, where the row repair will be made. After tRCD time, a WR command is used to select the individual DRAM, through the DQ bits, to transfer the repair address into an internal register in the DRAM. After a write recovery time and PRE command, the sPPR mode can be exited and normal operation can resume. The DRAM will retain the sPPR change as long as VDD remains within the operating region. If the DRAM power is removed or the DRAM is RESET, all sPPR changes will revert to the unrepaired state. sPPR changes must be cleared by either a power-up sequence or re-initialization by RESET signal before hPPR mode is enabled.

DDR4 sPPR can repair one row per Bank, however when the hPPR resources for a bank have been used, sPPR resources are no longer available for that bank. If a sPPR or hPPR repair sequence is issued to a bank with PPR resource un-available, the DRAM will ignore the programming sequence.

The bank receiving sPPR change is expected to retain array data in all other rows except for the seed row and its associated row addresses. If the user does not require the data in the array in the bank under sPPR repair to be retained, then the handling of the seed row's associated row addresses is not of interest and can be ignored. If the user requires the data in the array to be retained in the bank under sPPR mode, then prior to executing the sPPR mode, the seed row and its associated row addresses should be backed up and restored after sPPR has been completed. The sPPR associated seed row addresses are specified in the Table below.

Table 63 – sPPR associated row address

sPPR Associated Row Addresses						
BA0	A16	A15	A14	A13	A1	A0

9.33.1 Soft Repair of a Fail Row Address

The following is the procedure of sPPR with WR command. Note that during the soft repair sequence, no refresh is allowed.

1. Before entering "sPPR" mode, all banks must be precharged; DBI and CRC Modes must be disabled.
2. Enable sPPR using MR4 bit "A5 = 1" and wait tMOD.
3. Issue Guard Key as four consecutive MR0 commands each with a unique address field A[16:0]. Each MR0 command should space by tMOD. MR0 Guard Key sequence is same as hPPR in Table 59.
4. Issue ACT command with the Bank and Row Fail address, Write data is used to select the individual DRAM in the Rank for repair.
5. A WR command is issued after tRCD, with VALID column address. The DRAM will ignore the column address given with the WR command.
6. After WL (WL=CWL+AL+PL), All DQs of Target DRAM should be LOW for 4tCK. If HIGH is driven to All DQs of a DRAM consecutively for equal to or longer than first 2tCK, then DRAM does not conduct sPPR. If all DQs are neither LOW for 4tCK nor HIGH for equal to or longer than first 2tCK, then sPPR mode execution is unknown.
7. Wait tWR for the internal repair register to be written and then issue PRE to the Bank.
8. Wait 20nS after PRE which allow DRAM to recognize repaired Row address.
9. Exit sPPR with setting MR4 bit "A5 = 0" and wait tMOD.
10. One soft repair address per Bank is allowed before a hard repair is required. When more than one sPPR request is made to the same Bank, the most recently issued sPPR address would replace the early issued one. In the case of conducting soft repair address in a different Bank, Repeat Step 2 to 9. During a soft Repair, Refresh command is not allowed between sPPR MRS entry and exit.

Once sPPR mode is exited, to confirm if target row is repaired correctly, the host can verify the repair by writing data into the target row and reading it back after sPPR exit with MR4 A[5] = 0.

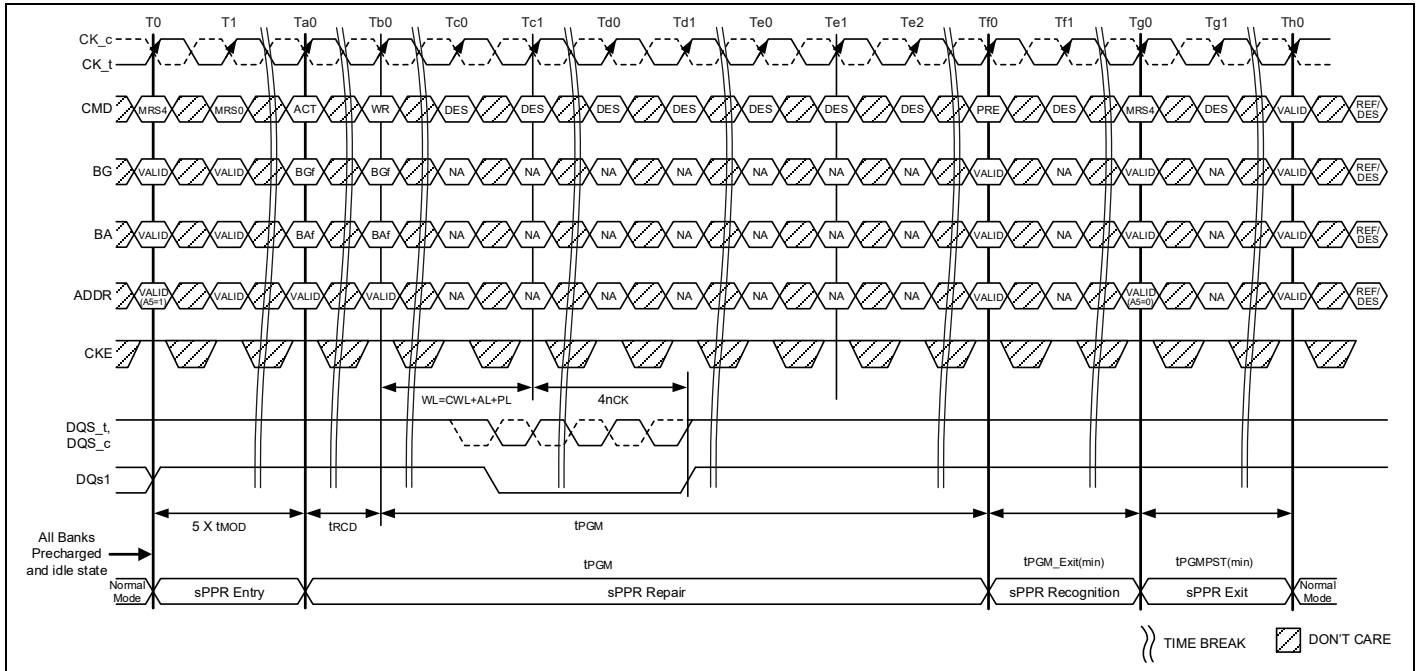

Figure 160 – Fail Row Soft PPR (WR Case)



10. On-Die Termination

ODT (On-Die Termination) is a feature of the DDR4 SDRAM that allows the DRAM to change termination resistance via the ODT control pin or Write Command or Default Parking value with MR setting. ODT is applied to each DQU, DQL, DQSU_t, DQSU_c, DQSL_t, DQSL_c, DMU_n and DML_n signal. The ODT feature is designed to improve signal integrity of the memory channel by allowing the DRAM controller to independently change termination resistance for any or all DRAM devices. More details about ODT control modes and ODT timing modes can be found further down in this section:

- The ODT control modes are described in section 10.1 “ODT Mode Register and ODT State Table”.
- The ODT synchronous mode is described in section 10.2 “Synchronous ODT Mode”.
- The Dynamic ODT feature is described in section 10.3 “Dynamic ODT”.
- The ODT asynchronous mode is described in section 10.4 “Asynchronous ODT mode”.
- The ODT buffer disable mode is described in section 10.5 “ODT buffer disabled mode for Power down”.

The ODT feature is turned off and not supported in Self-Refresh mode. A simple functional representation of the DRAM ODT feature is shown in Figure 161.

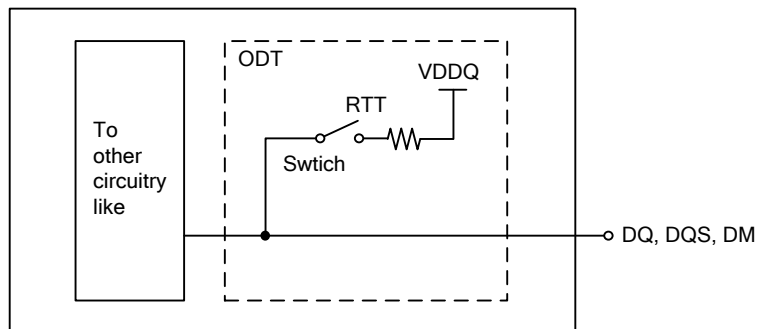

Figure 161 – Functional Representation of ODT

The switch is enabled by the internal ODT control logic, which uses the external ODT pin and Mode Register Setting and other control information, see below. The value of RTT is determined by the settings of Mode Register bits (see MR1 of section 8.5 Mode Register). The ODT pin will be ignored if the Mode Register MR1 is programmed to disable RTT_NOM (MR1 A[10:8] = 000) and in self-refresh mode.

10.1 ODT Mode Register and ODT State Table

The ODT Mode of DDR4 SDRAM has four states, Data Termination Disable, RTT_WR, RTT_NOM and RTT_PARK. And the ODT Mode is enabled if any of MR1 A[10:8] (RTT_NOM) or MR2 A[11:9] (RTT_WR) or MR5 A[8:6] (RTT_PARK) are non zero. In this case, the value of RTT is determined by the settings of those bits.

After entering Self-Refresh mode, DRAM automatically disables ODT termination and set Hi-Z as termination state regardless of these setting.

Application: Controller can control each RTT condition with WR/RD command and ODT pin.

- RTT_WR: The rank that is being written to provide termination regardless of ODT pin status. (either HIGH or LOW)
- RTT_NOM: DRAM turns ON RTT_NOM if it sees ODT asserted (except ODT is disabled by MR1).
- RTT_PARK: Default parked value set via MR5 to be enabled and ODT pin is driven LOW.
- Data Termination Disable: DRAM driving data upon receiving READ command disables the termination after RL-X and stays off for duration of BL/2 + X clock cycles. (X is 2 for 1tCK and 3 for 2tCK preamble mode.)



- The Termination State Table is shown in Table 64.

Those RTT values have priority as following.

1. Data Termination Disable
2. RTT_WR
3. RTT_NOM
4. RTT_PARK

which means if there is WRITE command along with ODT pin HIGH, then DRAM turns on RTT_WR not RTT_NOM, and also if there is READ command, then DRAM disables data termination regardless of ODT pin and goes into Driving mode.

Table 64 – Termination State Table

RTT_PARK MR5 A[8:6]	RTT_NOM MR1 A[10:8]	ODT pin	DRAM termination state	Note
Enabled	Enabled	HIGH	RTT_NOM	1, 2
		LOW	RTT_PARK	1, 2
	Disabled	Don't care*3	RTT_PARK	1, 2
Disabled	Enabled	HIGH	RTT_NOM	1, 2
		LOW	Hi-Z	1, 2
	Disabled	Don't care*3	Hi-Z	1, 2

Notes:

1. When a read command is executed, DRAM termination state will be Hi-Z for defined period independent of ODT pin and MR setting of RTT_PARK/RTT_NOM. This is described in section 10.2.3 “ODT during Reads”.
2. If RTT_WR is enabled, RTT_WR will be activated by Write command for defined period time independent of ODT pin and MR setting of RTT_PARK /RTT_NOM. This is described in section 10.3 “Dynamic ODT”.
3. If RTT_NOM MRS is disabled, ODT receiver power will be turned off to save power.

On-Die Termination effective resistance RTT is defined by MRS bits.

ODT is applied to the DQU[7:0], DQL[7:0], DQSU_t, DQSU_c, DQSL_t, DQSL_c, DMU_n and DML_n pins.

A functional representation of the on-die termination is shown in the figure below.

$$RTT = \frac{VDDQ - V_{out}}{|I_{out}|}$$

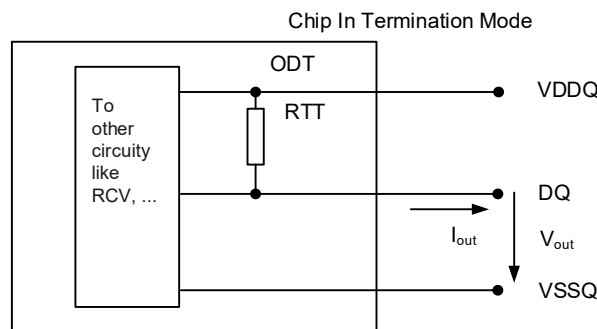

Figure 162 – On Die Termination

On die termination effective Rtt values supported are 240, 120, 80, 60, 48, 40, 34 ohms.



Table 65 – ODT Electrical Characteristics RZQ=240Ω ±1% entire temperature operation range; after proper ZQ calibration

RTT	Vout	Min	Nom	Max	Unit	Notes
240Ω	VOLdc= 0.5* VDDQ	0.9	1	1.25	RZQ	1,2,3,7
	VOMdc= 0.8* VDDQ	0.9	1	1.1	RZQ	1,2,3,7
	VOHdc= 1.1* VDDQ	0.8	1	1.1	RZQ	1,2,3,7
120Ω	VOLdc= 0.5* VDDQ	0.9	1	1.25	RZQ/2	1,2,3,7
	VOMdc= 0.8* VDDQ	0.9	1	1.1	RZQ/2	1,2,3,7
	VOHdc= 1.1* VDDQ	0.8	1	1.1	RZQ/2	1,2,3,7
80Ω	VOLdc= 0.5* VDDQ	0.9	1	1.25	RZQ/3	1,2,3,7
	VOMdc= 0.8* VDDQ	0.9	1	1.1	RZQ/3	1,2,3,7
	VOHdc= 1.1* VDDQ	0.8	1	1.1	RZQ/3	1,2,3,7
60Ω	VOLdc= 0.5* VDDQ	0.9	1	1.25	RZQ/4	1,2,3,7
	VOMdc= 0.8* VDDQ	0.9	1	1.1	RZQ/4	1,2,3,7
	VOHdc= 1.1* VDDQ	0.8	1	1.1	RZQ/4	1,2,3,7
48Ω	VOLdc= 0.5* VDDQ	0.9	1	1.25	RZQ/5	1,2,3,7
	VOMdc= 0.8* VDDQ	0.9	1	1.1	RZQ/5	1,2,3,7
	VOHdc= 1.1* VDDQ	0.8	1	1.1	RZQ/5	1,2,3,7
40Ω	VOLdc= 0.5* VDDQ	0.9	1	1.25	RZQ/6	1,2,3,7
	VOMdc= 0.8* VDDQ	0.9	1	1.1	RZQ/6	1,2,3,7
	VOHdc= 1.1* VDDQ	0.8	1	1.1	RZQ/6	1,2,3,7
34Ω	VOLdc= 0.5* VDDQ	0.9	1	1.25	RZQ/7	1,2,3,7
	VOMdc= 0.8* VDDQ	0.9	1	1.1	RZQ/7	1,2,3,7
	VOHdc= 1.1* VDDQ	0.8	1	1.1	RZQ/7	1,2,3,7
DQ-DQ Mismatch within byte	VOMdc= 0.8* VDDQ	0	-	10	%	1,2,4,5,6

Notes:

- The tolerance limits are specified after calibration with stable voltage and temperature. For the behavior of the tolerance limits if temperature or voltage changes after calibration, see following section on voltage and temperature sensitivity.
- Pull-up ODT resistors are recommended to be calibrated at 0.8*VDDQ. Other calibration schemes may be used to achieve the linearity spec shown above, e.g. calibration at 0.5*VDDQ and 1.1*VDDQ.
- The tolerance limits are specified under the condition that VDDQ=VDD and VSSQ=VSS
- DQ to DQ mismatch within byte variation for a given component including DQS_t and DQS_c (characterized)
- RTT variance range ratio to RTT Nominal value in a given component, including DQS_t and DQS_c.

$$\text{DQ Mismatch in a Device} = \frac{\text{RTTMax} - \text{RTTMin}}{\text{RTTNOM}} * 100$$

- This parameter of x16 device is specified for Upper byte and Lower byte.
- For Industrial/Industrial plus grade parts device, the minimum values are reduced by 9%.

10.1.1 ODT Temperature and Voltage sensitivity

If temperature and/or voltage change after calibration, the tolerance limits widen according to the following definitions are used:

$\Delta T = T - T$ (@calibration); $\Delta V = VDDQ - VDDQ$ (@calibration); $VDD = VDDQ$

ODT Sensitivity Definition

SYMBOL	MIN.	MAX.	UNIT
RTT	$0.9 - dR_{TTdT} \times \Delta T - dR_{TTdV} \times \Delta V $	$1.6 + dR_{TTdT} \times \Delta T + dR_{TTdV} \times \Delta V $	RZQ/2, 4, 5, 6, 7

ODT Voltage and Temperature Sensitivity

SYMBOL	MIN.	MAX.	UNIT
dR _{TTdT}	0	1.5	%/°C
dR _{TTdV}	0	0.15	%/mV

Note: These parameters may not be subject to production test. They are verified by design and characterization

Publication Release Date: Dec. 26, 2024

Revision: A03



10.2 Synchronous ODT Mode

Synchronous ODT mode is selected whenever the DLL is turned on and locked. Based on the power-down definition, these modes are:

- Any bank active with CKE high
- Refresh with CKE high
- Idle mode with CKE high
- Active power down mode
- Precharge power down mode

In synchronous ODT mode, RTT_NOM will be turned on DODTLon clock cycles after ODT is sampled HIGH by a rising clock edge and turned off DODTLoFF clock cycles after ODT is registered LOW by a rising clock edge. The ODT latency is tied to the Write Latency ($WL = CWL + AL + PL$) by: $DODTLon = WL - 2$; $DODTLoFF = WL - 2$.

When operating in 2tCK Preamble Mode, The ODT latency must be 1 clock smaller than in 1tCK Preamble Mode; $DODTLon = WL - 3$; $DODTLoFF = WL - 3$. ($WL = CWL + AL + PL$)

10.2.1 ODT Latency and Posted ODT

In Synchronous ODT Mode, the Additive Latency (AL) and the Parity Latency (PL) programmed into the Mode Register (MR1) applies to ODT Latencies as shown in Table 66 and Table 67. For details, refer to DDR4 SDRAM latency definitions.

Table 66 – ODT Latency

Symbol	Parameter	DDR4-1600/1866/2133/2400/2666/3200	Unit
DODTLon	Direct ODT turn on Latency	$CWL + AL + PL - 2$	tCK
DODTLoFF	Direct ODT turn off Latency	$CWL + AL + PL - 2$	
RODTLoFF	Read command to internal ODT turn off Latency	See detail Table 67	
RODTLon4	Read command to RTT_PARK turn on Latency in BC4	See detail Table 67	
RODTLon8	Read command to RTT_PARK turn on Latency in BC8/BL8	See detail Table 67	

Table 67 – Read command to ODT off/on Latency variation by Preamble

Symbol	1tCK Preamble	2tCK Preamble	Unit
RODTLoFF	$CL + AL + PL - 2$	$CL + AL + PL - 3$	tCK
RODTLon4	$RODTLoFF + 4$	$RODTLoFF + 5$	
RODTLon8	$RODTLoFF + 6$	$RODTLoFF + 7$	
ODTH4	4	5	
ODTH8	6	7	



10.2.2 Timing Parameters

In synchronous ODT mode, the following timing parameters apply:

DODTLon, DODTLoFF, RODTLoff, RODTLon4, RODTLon8, tADC,min,max.

tADC,min and tADC,max are minimum and maximum RTT change timing skew between different termination values. Those timing parameters apply to both the Synchronous ODT mode and the Data Termination Disable mode.

When ODT is asserted, it must remain HIGH until minimum ODT_{H4} (BL=4) or ODT_{H8} (BL=8) is satisfied. Additionally, depending on CRC or 2tCK preamble setting in MRS, ODT_H should be adjusted.

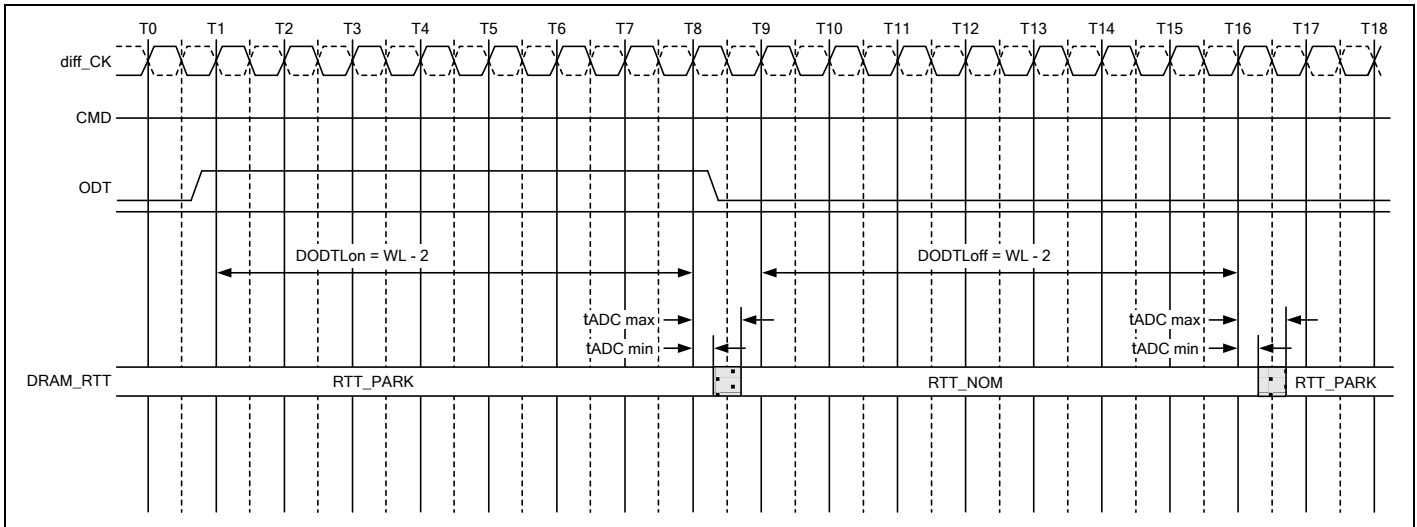

Figure 163 – Synchronous ODT Timing Example for CWL=9, AL=0, PL=0; DODTLon=WL-2=7; DODTLoFF=WL-2=7

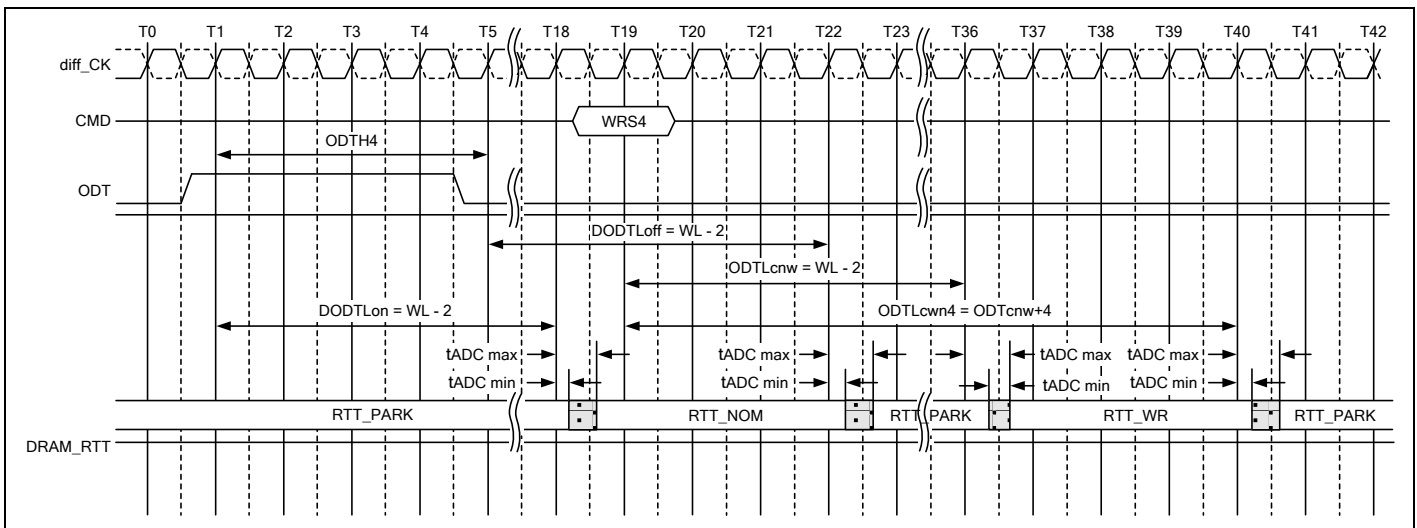

Figure 164 – Synchronous ODT example with BL=4, CWL=9, AL=10, PL=0; DODTLon/off=WL-2=17, ODTcHw=WL-2=17

ODT must be held HIGH for at least ODT_{H4} after assertion (T1). ODT_H is measured from ODT first registered HIGH to ODT first registered LOW, or from registration of Write command. Note that ODT_{H4} should be adjusted depending on CRC or 2tCK preamble setting



10.2.3 ODT during Reads

As the DDR4 SDRAM cannot terminate and drive at the same time. RTT may nominally not be enabled until the end of the postamble as shown in the example below. As shown in Figure 165 below at cycle T25, DRAM turns on the termination when it stops driving which is determined by tHZ. If DRAM stops driving early (i.e tHZ is early) then tADC, min timing may apply. If DRAM stops driving late (i.e. tHZ is late) then DRAM complies with tADC,max timing.

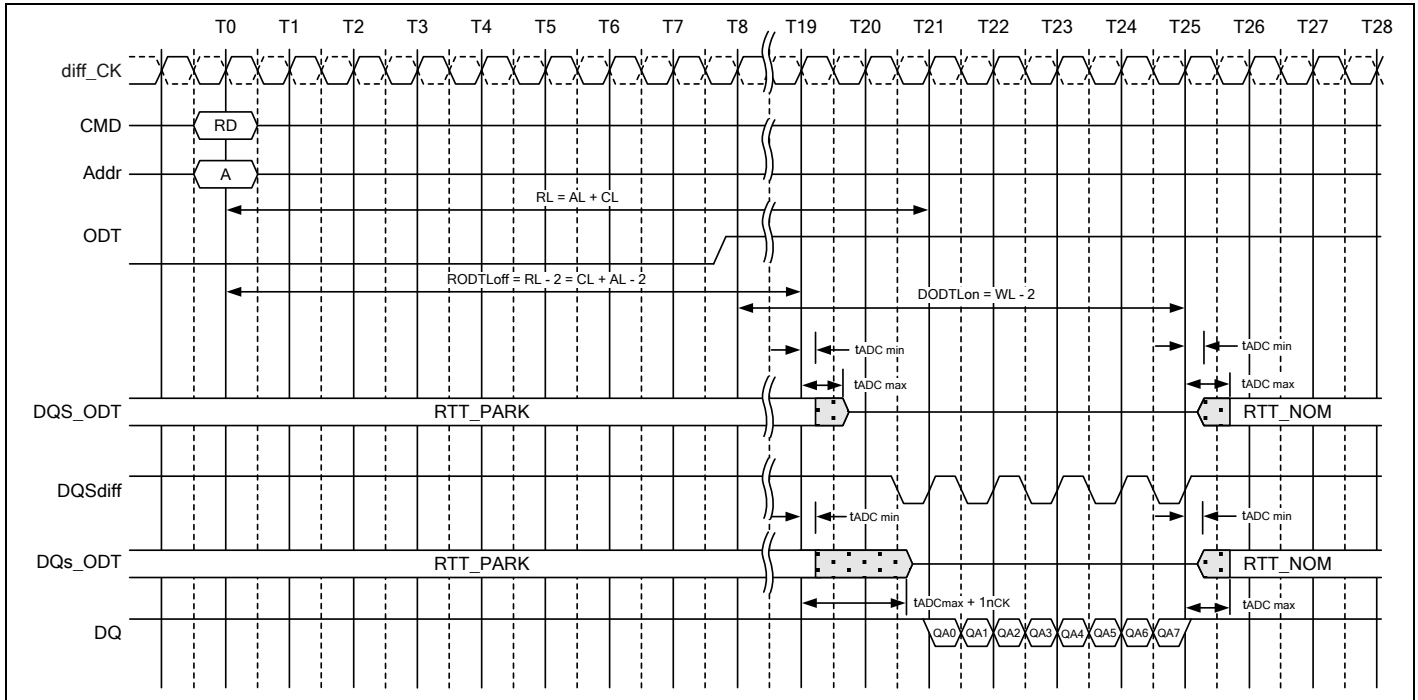

Figure 165 – Example: CL=11, PL=0; AL=CL-1=10; RL=AL+PL+CL=21; CWL=9; DODTLon=AL+CWL-2=17; RODTLoft=CL+AL-2=19; 1tCK preamble

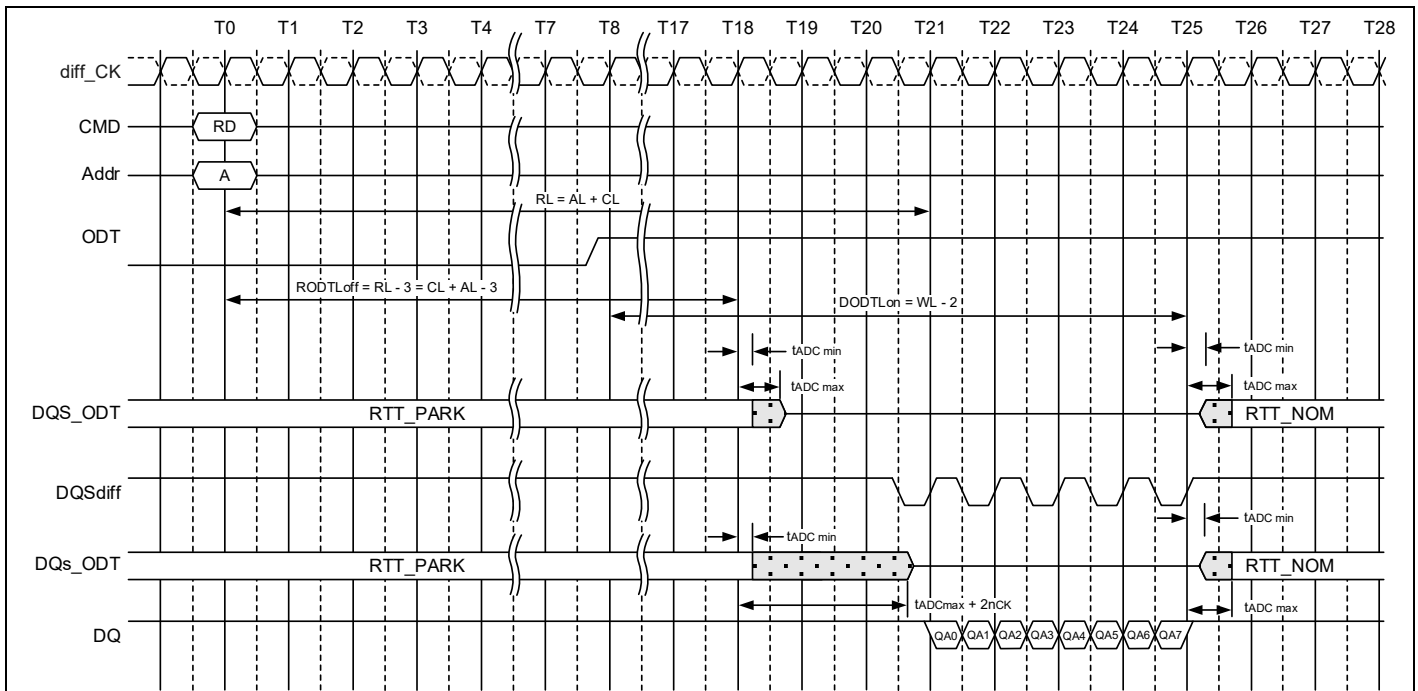

Figure 166 – Example: CL=11, PL=0; AL=CL-1=10; RL=AL+PL+CL=21; CWL=9; DODTLon=AL+CWL-2=17; RODTLoft=CL+AL-3=18; 2tCK preamble



10.3 Dynamic ODT

In certain application cases and to further enhance signal integrity on the data bus, it is desirable that the termination strength of the DDR4 SDRAM can be changed without issuing an MRS command. This requirement is supported by the “Dynamic ODT” feature as described as follows:

10.3.1 Functional Description

The Dynamic ODT Mode is enabled if bit A[9] or A[10] or A[11] of MR2 is set to “1”. The function is described as follows:

- Three RTT values are available: RTT_NOM, RTT_PARK and RTT_WR.
 - The value for RTT_NOM is preselected via bits A[10:8] in MR1
 - The value for RTT_PARK is preselected via bits A[8:6] in MR5
 - The value for RTT_WR is preselected via bits A[11:9] in MR2
- During operation without commands, the termination is controlled as follows;
 - Nominal termination strength RTT_NOM or RTT_PARK is selected.
 - RTT_NOM on/off timing is controlled via ODT pin and latencies DODTLon and DODTLoff and RTT_PARK is on when ODT is LOW.
- When a write command (WR, WRA, WRS4, WRS8, WRAS4, WRAS8) is registered, and if Dynamic ODT is enabled, the termination is controlled as follows:
 - A latency ODTLcnw after the write command, termination strength RTT_WR is selected.
 - A latency ODTLcwn8 (for BL8, fixed by MRS or selected OTF) or ODTLcwn4 (for BC4, fixed by MRS or selected OTF) after the write command, termination strength RTT_WR is de-selected.
 - 1 or 2 clocks will be added or subtracted into/from ODTLcwn8 and ODTLcwn4 depending on CRC and/or 2tCK preamble setting.

Table 68 shows latencies and timing parameters which are relevant for the on-die termination control in Dynamic ODT mode.

The Dynamic ODT feature is not supported at DLL-off mode. User must use MRS command to set Rtt_WR, MR2 A[11:9] = 000 externally.

Table 68 – Latencies and timing parameters relevant for Dynamic ODT with 1tCK preamble mode and CRC disabled

Name and Description	Abbr.	Defined from	Define to	1600/1866/ 2133/2400	2666	3200	Unit
ODT Latency for changing from RTT_PARK/RTT_NOM to RTT_WR	ODTLcnw	Registering external write command	Change RTT strength from RTT_PARK/RTT_Nom to RTT_WR	ODTLcnw = WL - 2			tCK
ODT Latency for change from RTT_WR to RTT_PARK/RTT_Nom (BL = 4)	ODTLcwn4	Registering external write command	Change RTT strength from RTT_WR to RTT_PARK/RTT_Nom	ODTLcwn4 = 4 + ODTLcnw			tCK
ODT Latency for change from RTT_WR to RTT_PARK/RTT_Nom (BL = 8)	ODTLcwn8	Registering external write command	Change RTT strength from RTT_WR to RTT_PARK/RTT_Nom	ODTLcwn8 = 6 + ODTLcnw			tCK(avg)
RTT change skew	tADC	ODTLcnw ODTLcwn	RTT valid	tADC(min) = 0.3 tADC(max) = 0.7	tADC(min) = 0.28 tADC(max) = 0.72	tADC(min) = 0.26 tADC(max) = 0.74	tCK(avg)

Table 69 – Latencies and timing parameters relevant for Dynamic ODT with 1 and 2tCK preamble mode and CRC en/disabled

Symbol	1tCK Preamble		2tCK Preamble		Unit
	CRC off	CRC on	CRC off	CRC on	
ODTLcnw	WL-2	WL-2	WL-3	WL-3	tCK
ODTLcwn4	ODTLcnw + 4	ODTLcnw + 7	ODTLcnw + 5	ODTLcnw + 8	
ODTLcwn8	ODTLcnw + 6	ODTLcnw + 7	ODTLcnw + 7	ODTLcnw + 8	



10.3.2 ODT Timing Diagrams

Figures 167 and 168 provide example Dynamic ODT timing diagrams.

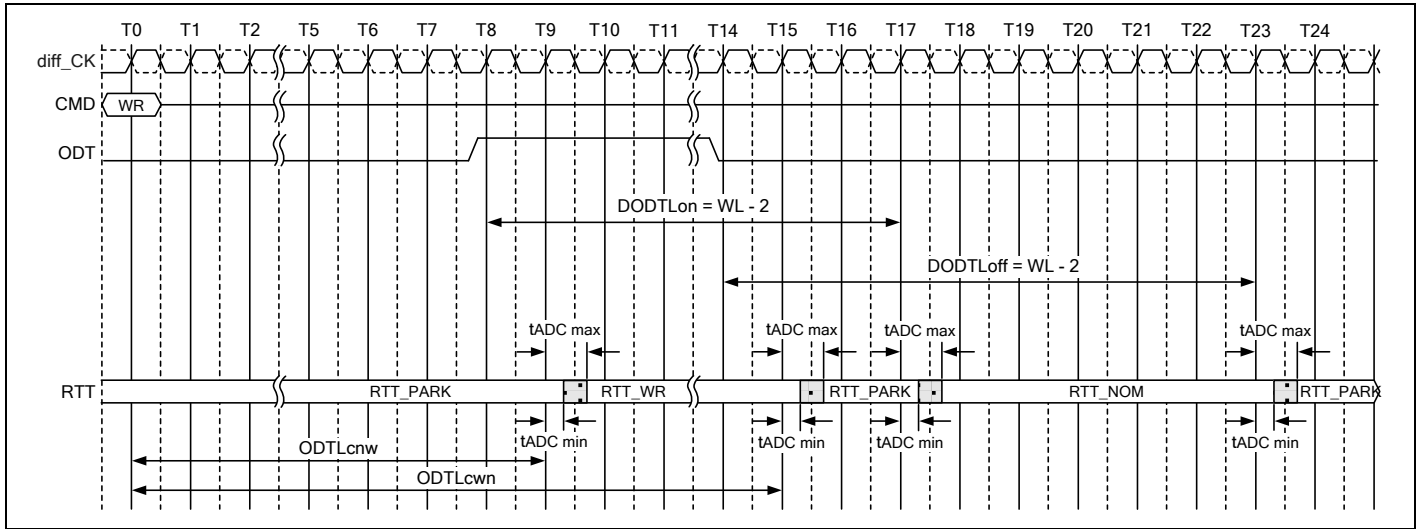

ODTLcwn = WL-2 (1tCK preamble), WL-3 (2tCK preamble)

ODTLcwn = WL+2 (BC4), WL+4 (BL8) w/o CRC or WL+5 (BC4, BL8 respectively) when CRC is enabled.

Figure 167 – ODT timing (Dynamic ODT, 1tCK preamble, CL=14, CWL=11, BL=8, AL=0, CRC Disabled)

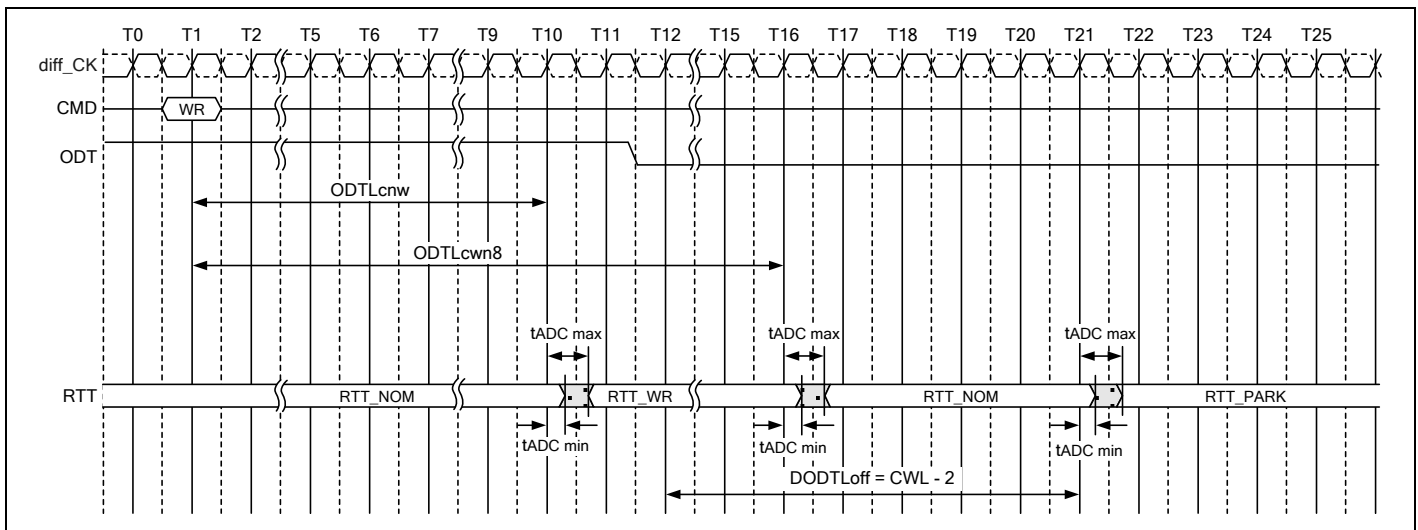

Behavior with WR command is issued while ODT is being registered high.

Figure 168 – Dynamic ODT overlapped with RTT_NOM (CL=14, CWL=11, BL=8, AL=0, CRC Disabled)



10.4 Asynchronous ODT mode

Asynchronous ODT mode is selected when DLL is disabled by MR1 bit A0 = “0”b.

In asynchronous ODT timing mode, internal ODT command is not delayed by either the Additive Latency (AL) or relative to the external ODT signal (RTT_NOM).

In asynchronous ODT mode, the following timing parameters apply tAONAS,min,max, tAOFAS,min,max.

Minimum RTT_NOM turn-on time (tAONASmin) is the point in time when the device termination circuit leaves RTT_PARK and ODT resistance begins to change. Maximum RTT_NOM turn on time (tAONASmax) is the point in time when the ODT resistance is reached RTT_NOM.

tAONASmin and tAONASmax are measured from ODT being sampled high.

Minimum RTT_NOM turn-off time (tAOFASmin) is the point in time when the devices termination circuit starts to leave RTT_NOM.

Maximum RTT_NOM turn-off time (tAOFASmax) is the point in time when the on-die termination has reached RTT_PARK.

tAOFASmin and tAOFASmax are measured from ODT being sampled low.

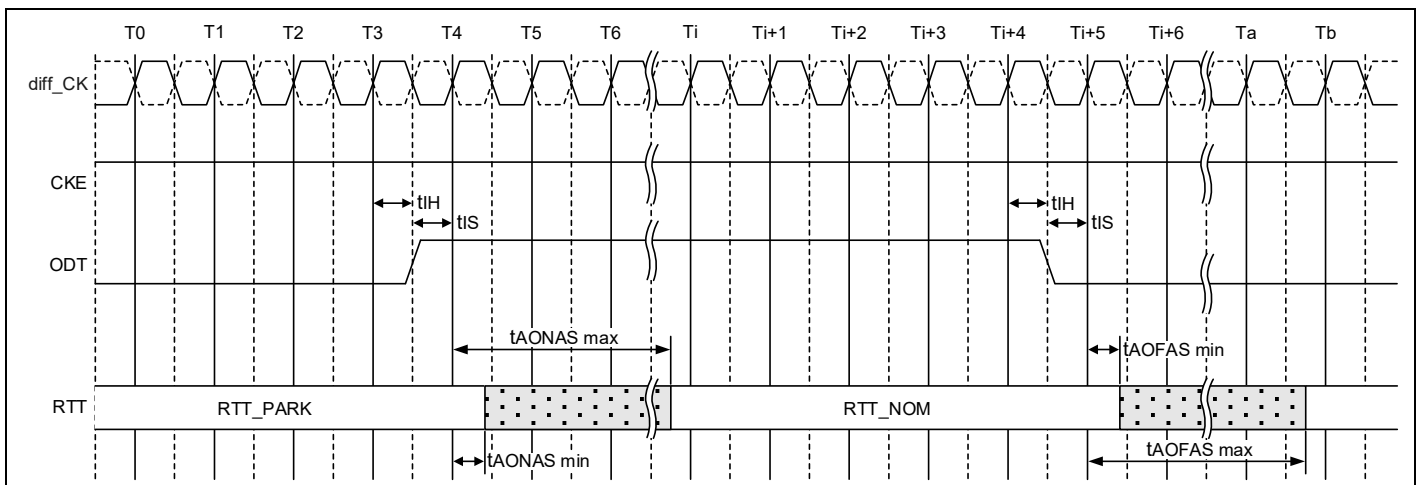

Figure 169 – Asynchronous ODT Timing on DDR4 SDRAM with DLL-off
ODT Timing on DDR4 SDRAM with DLL-off

Table 70 – Asynchronous ODT Timing Parameters for all Speed Bins

Description	Symbol	min	max	Unit
Asynchronous RTT turn-on delay	tAONAS	1	9	nS
Asynchronous RTT turn-off delay	tAOFAS	1	9	nS



10.5 ODT buffer disabled mode for Power down

DRAM does not provide RTT_NOM termination during power down when ODT input buffer deactivation mode is enabled in MR5 bit A5. To account for DRAM internal delay on CKE line to disable the ODT buffer and block the sampled output, the host controller must continuously drive ODT to either low or high when entering power down (from $t_{DODT\text{off}+1}$ prior to CKE low till t_{CPDED} after CKE low). The ODT signal is allowed to float after $t_{CPDED\text{min}}$ has expired. In this mode, RTT_NOM termination corresponding to sampled ODT at the input when CKE is registered low (and t_{ANPD} before that) may be either RTT_NOM or RTT_PARK. t_{ANPD} is equal to (WL-1) and is counted backwards from PDE.

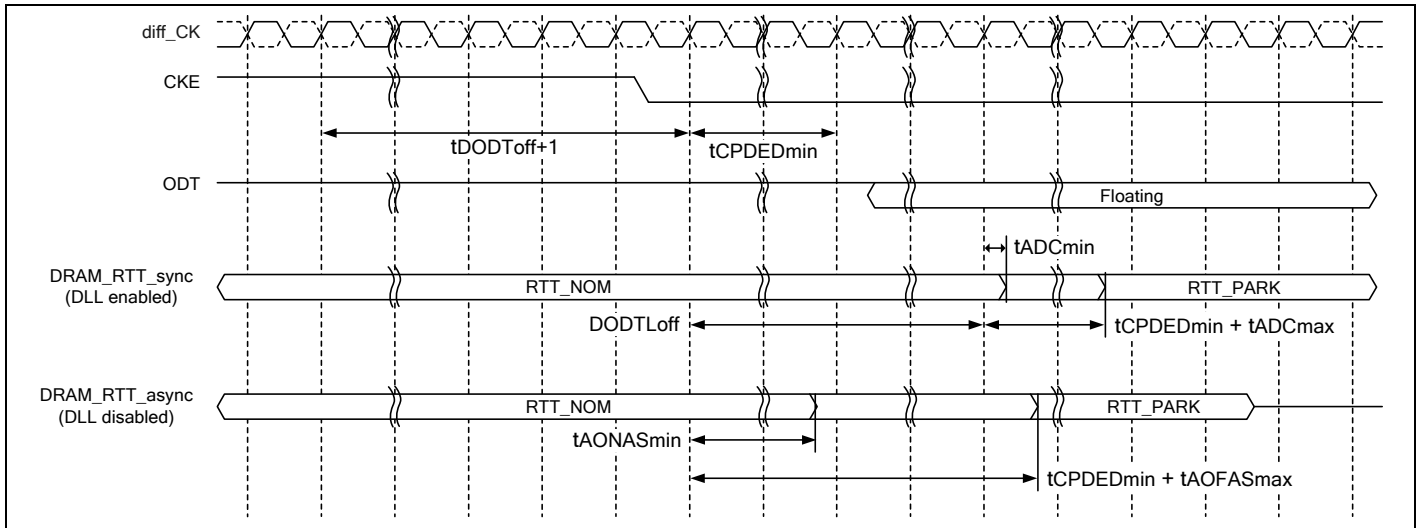

Figure 170 – ODT timing for power down entry with ODT buffer disable mode

When exit from power down, along with CKE being registered high, ODT input signal must be re-driven and maintained low until t_{XP} is met.

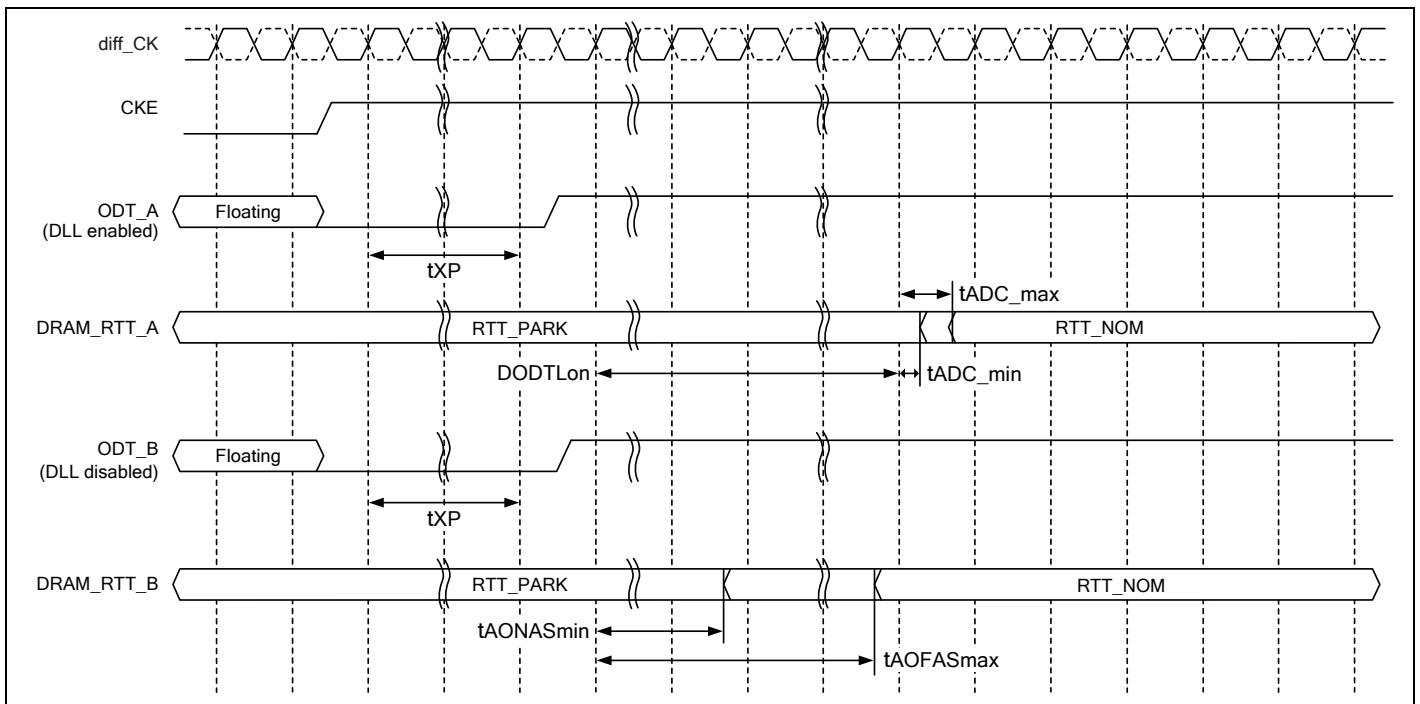

Figure 171 – ODT timing for power down exit with ODT buffer disable mode



10.6 ODT Timing Definitions

10.6.1 Test Load for ODT Timings

Different than for timing measurements, the reference load for ODT timings is defined in Figure 172.

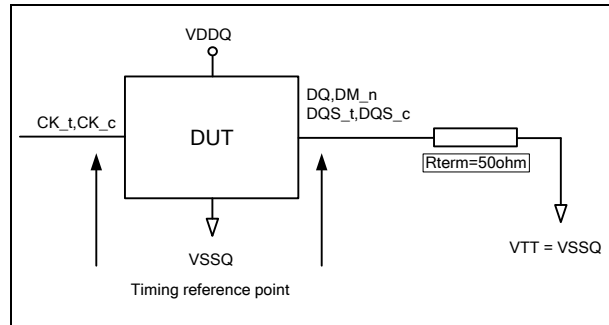

Figure 172 – ODT Timing Reference Load

10.6.2 ODT Timing Definitions

Definitions for tADC, tAONAS and tAOFAS are provided in Table 71 and subsequent figures. Measurement reference settings are provided in Table 72. tADC of Dynamic ODT case and Read Disable ODT case are represented by tADC of Direct ODT Control case.

Table 71 – ODT Timing Definitions

Symbol	Begin Point Definition	End Point Definition	Figure	Note
tADC	Rising edge of CK_t,CK_c defined by the end point of DODTLoff	Extrapolated point at VRTT_NOM	Figure 173	
	Rising edge of CK_t,CK_c defined by the end point of DODTLon	Extrapolated point at VSSQ		
	Rising edge of CK_t,CK_c defined by the end point of ODTLcnw	Extrapolated point at VRTT_NOM	Figure 174	
	Rising edge of CK_t,CK_c defined by the end point of ODTLcwn4 or ODTLcwn8	Extrapolated point at VSSQ		
tAONAS	Rising edge of CK_t,CK_c with ODT being first registered high	Extrapolated point at VSSQ	Figure 175	
tAOFAS	Rising edge of CK_t,CK_c with ODT being first registered low	Extrapolated point at VRTT_NOM		

Table 72 – Reference Settings for ODT Timing Measurements

Measured Parameter	RTT_PARK	RTT_NOM	RTT_WR	Vsw1	Vsw2	Figure	Note
tADC	Disable	RZQ/7	-	0.2V	0.4V	Figure 173	1, 2
	-	RZQ/7	Hi-Z	0.2V	0.4V	Figure 174	1, 3
tAONAS	Disable	RZQ/7	-	0.2V	0.4V	Figure 175	1, 2
tAOFAS	Disable	RZQ/7	-	0.2V	0.4V		

Notes:

- MR setting is as follows.
 - MR1 A10=1, A9=1, A8=1 (RTT_NOM_Setting)
 - MR5 A8=0, A7=0, A6=0 (RTT_PARK_Setting)
 - MR2 A11=0, A10=1, A9=1 (RTT_WR_Setting)
- ODT state change is controlled by ODT pin.
- ODT state change is controlled by Write Command.

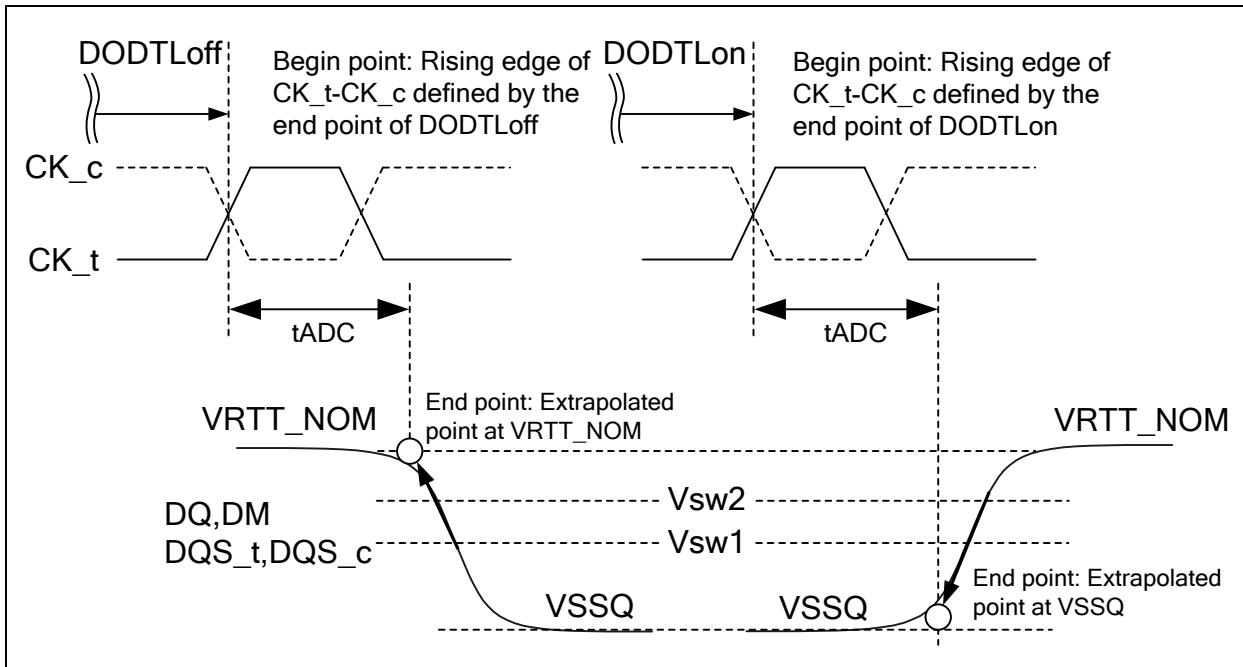

Figure 173 – Definition of tADC at Direct ODT Control

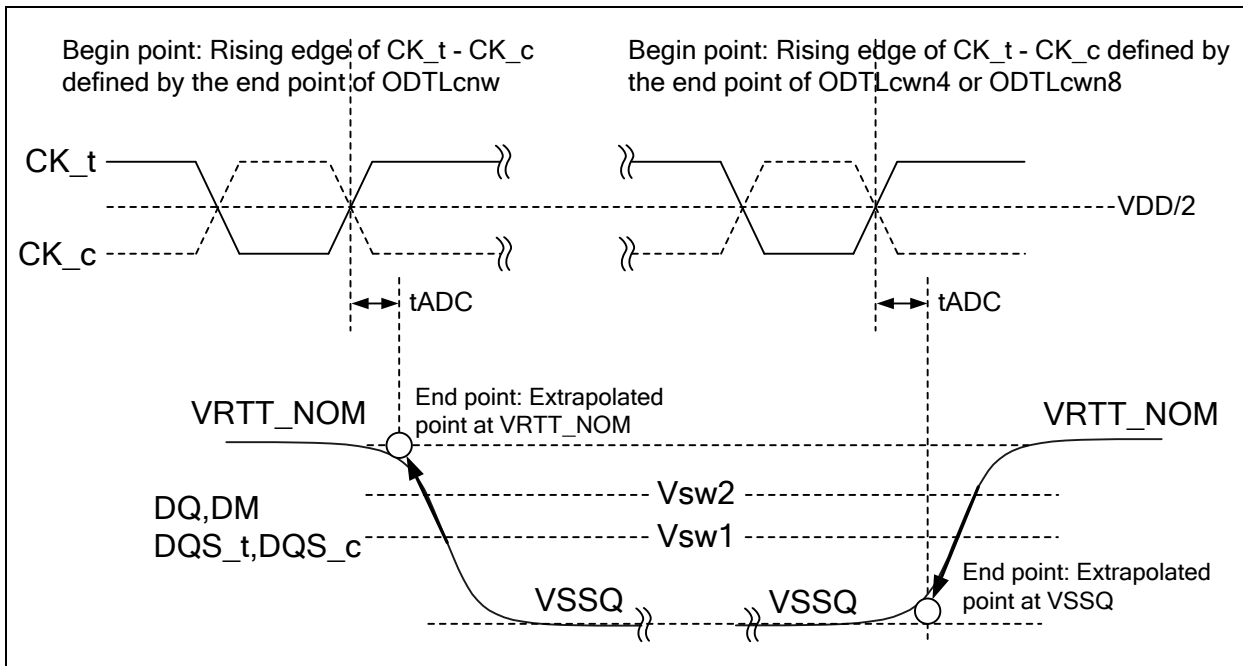

Figure 174 – Definition of tADC at Dynamic ODT Control

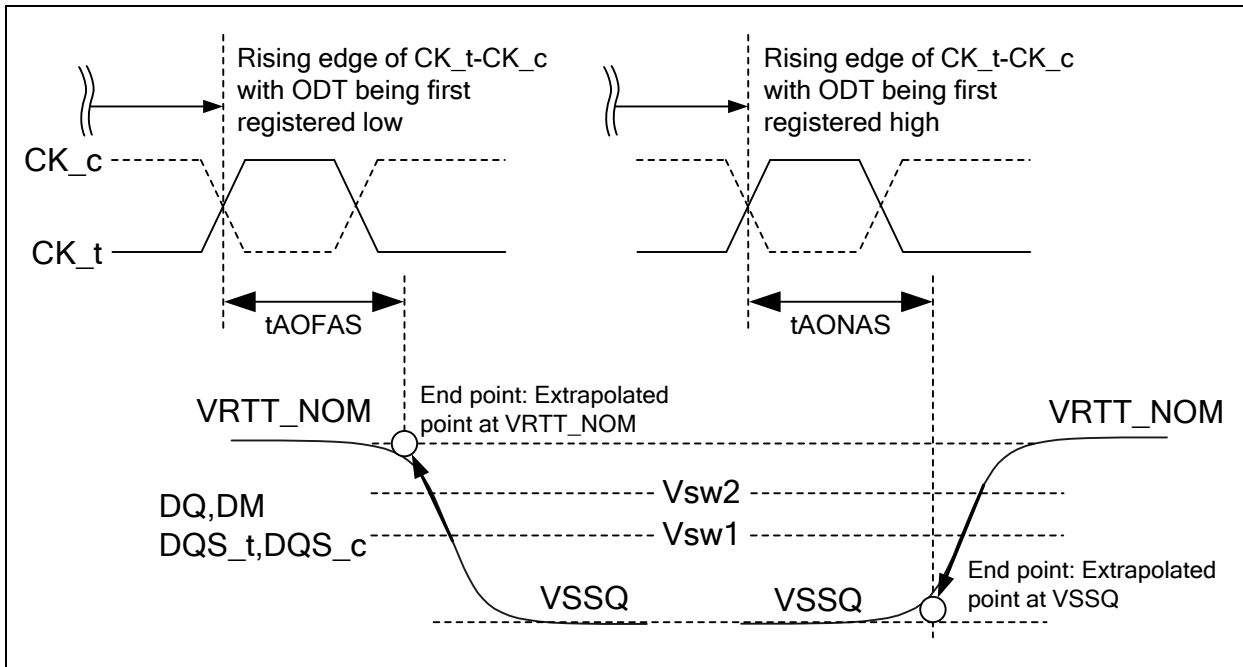

Figure 175 – Definition of t_{AOFAS} and t_{AONAS}



11. Absolute Maximum Ratings

Table 73 – Absolute Maximum DC Ratings

Symbol	Parameter	Rating	Units	Notes
VDD	Voltage on VDD pin relative to Vss	-0.3 ~ 1.5	V	1, 3
VDDQ	Voltage on VDDQ pin relative to Vss	-0.3 ~ 1.5	V	1, 3
VPP	Voltage on VPP pin relative to Vss	-0.3 ~ 3.0	V	4
V _{IN} , V _{OUT}	Voltage on any pin except VREFCA relative to Vss	-0.3 ~ 1.5	V	1, 3, 5
T _{STG}	Storage Temperature	-55 ~ 150	°C	1, 2

Notes:

- Stresses greater than those listed under “Absolute Maximum Ratings” may cause permanent damage to the device. This is a stress rating only and functional operation of the device at these or any other conditions above those indicated in the operational sections of this specification is not implied. Exposure to absolute maximum rating conditions for extended periods may affect reliability.
- Storage Temperature is the case surface temperature on the center/top side of the DRAM. For the measurement conditions, please refer to JEDEC51-2 standard.
- VDD and VDDQ must be within 300 mV of each other at all times; and VREFCA must be not greater than 0.6 x VDDQ, When VDD and VDDQ are less than 500 mV; VREFCA may be equal to or less than 300 mV
- VPP must be equal or greater than VDD/VDDQ at all times.
- Overshoot area above 1.5 V is specified in 12.3.4, 12.3.5, and 12.3.6.

12. AC and DC Operating Conditions

Table 74 – Recommended DC Operating Conditions

Symbol	Parameter	Rating			Unit	Notes
		Min	Typ	Max		
VDD	Supply Voltage	1.14	1.2	1.26	V	1, 2, 3
VDDQ	Supply Voltage for Output	1.14	1.2	1.26	V	1, 2, 3
VPP		2.375	2.5	2.75	V	3

Notes:

- Under all conditions VDDQ must be less than or equal to VDD.
- VDDQ tracks with VDD. AC parameters are measured with VDD and VDDQ tied together.
- DC bandwidth is limited to 20MHz.

12.1 AC and DC Logic input levels for single-ended signals

Table 75 – Single-ended AC & DC input levels for Command Address

Symbol	Parameter	DDR4-1600/1866/2133/2400		DDR4-2666/3200		Unit	Notes
		Min	Max	Min	Max		
V _{IH,CA} (DC75)	DC input logic high	V _{REFCA} + 0.075	V _{DD}	-	-	V	
V _{IL,CA} (DC75)	DC input logic low	V _{SS}	V _{REFCA} - 0.075	-	-	V	
V _{IH,CA} (DC65)	DC input logic high	-	-	V _{REFCA} + 0.065	V _{DD}	V	
V _{IL,CA} (DC65)	DC input logic low	-	-	V _{SS}	V _{REFCA} - 0.065	V	
V _{IH,CA} (AC100)	AC input logic high	V _{REF} + 0.1	Note 2	-	-	V	1
V _{IL,CA} (AC100)	AC input logic low	Note 2	V _{REF} - 0.1	-	-	V	1
V _{IH,CA} (AC90)	AC input logic high	-	-	V _{REF} + 0.09	Note 2	V	1
V _{IL,CA} (AC90)	AC input logic low	-	-	Note 2	V _{REF} - 0.09	V	1
V _{REFCA} (DC)	Reference Voltage for ADD, CMD inputs	0.49*V _{DD}	0.51*V _{DD}	0.49*V _{DD}	0.51*V _{DD}	V	2, 3

Notes:

- See “Overshoot and Undershoot Specifications” in 12.3.4.
- The AC peak noise on VREFCA may not allow VREFCA to deviate from VREFCA(DC) by more than ± 1% VDD (for reference: approx. ± 12mV)
- For reference: approx. VDD/2 ± 12 mV.



12.2 AC and DC Input Measurement Levels: VREF Tolerances

The DC-tolerance limits and ac-noise limits for the reference voltages VREFCA is illustrated in Figure 176. It shows a valid reference voltage VREF(t) as a function of time. (VREF stands for VREFCA).

VREF(DC) is the linear average of VREF(t) over a very long period of time (e.g. 1 sec). This average has to meet the min/max requirement in Table 75. Furthermore VREF(t) may temporarily deviate from VREF(DC) by no more than $\pm 1\%$ VDD.

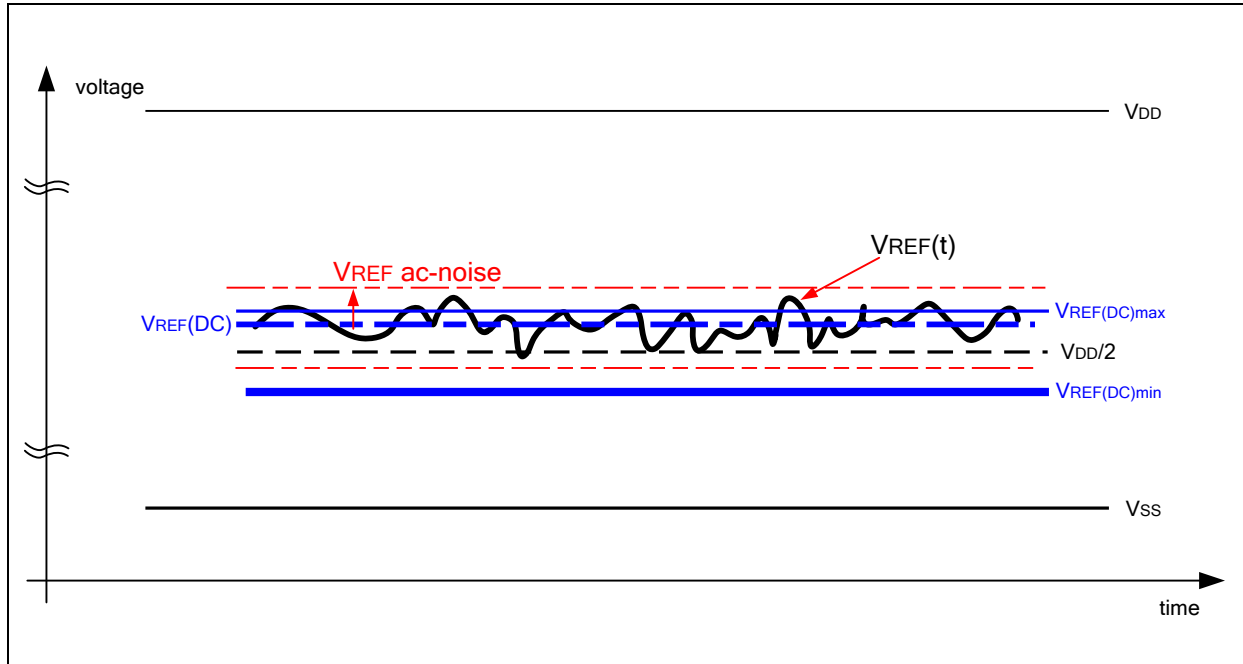

Figure 176 – Illustration of VREF(DC) tolerance and VREF AC-noise limits

The voltage levels for setup and hold time measurements VIH(AC), VIH(DC), VIL(AC) and VIL(DC) are dependent on VREF.

“VREF” shall be understood as VREF(DC), as defined in Figure 176.

This clarifies, that DC-variations of VREF affect the absolute voltage a signal has to reach to achieve a valid high or low level and therefore the time to which setup and hold is measured. System timing and voltage budgets need to account for VREF(DC) deviations from the optimum position within the data-eye of the input signals.

This also clarifies that the DRAM setup/hold specification and derating values need to include time and voltage associated with VREF AC-noise. Timing and voltage effects due to AC-noise on VREF up to the specified limit ($\pm 1\%$ of VDD) are included in DRAM timings and their associated deratings.



12.3 AC and DC Logic Input Levels for Differential Signals

12.3.1 Differential signal definition

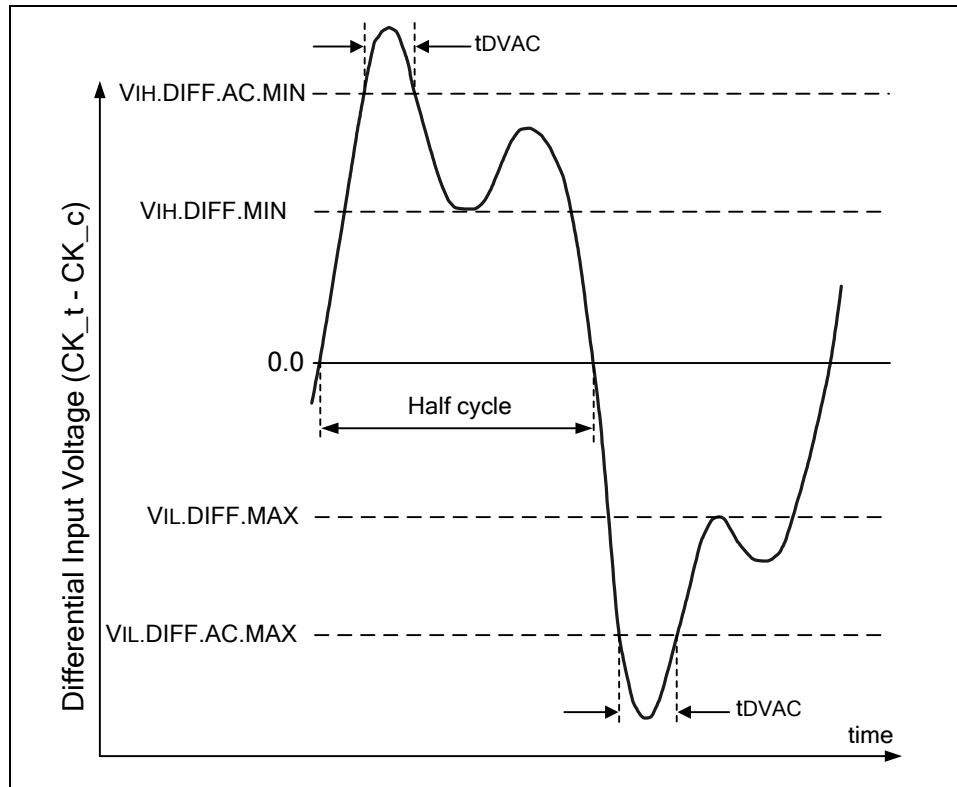

Notes:

1. Differential signal rising edge from VIL.DIFF.MAX to VIH.DIFF.MIN must be monotonic slope.
2. Differential signal falling edge from VIH.DIFF.MIN to VIL.DIFF.MAX must be monotonic slope.

Figure 177 – Definition of differential ac-swing and “time above ac-level” tdVAC

12.3.2 Differential swing requirements for clock (CK_t - CK_c)

Table 76 – Differential AC and DC Input Levels

Symbol	Parameter	DDR4-1600/1866/2133		DDR4-2400/2666		DDR4-3200		Unit	Notes
		Min	Max	Min	Max	Min	Max		
VIHdiff	differential input high	150	Note 3	135	Note 3	110	Note 3	mV	1
VILdiff	differential input low	Note 3	-150	Note 3	-135	Note 3	-110	mV	1
VIHdiff(AC)	differential input high ac	2 x (VIH(AC) - VREF)	Note 3	2 x (VIH(AC) - VREF)	Note 3	2 x (VIH(AC) - VREF)	Note 3	V	2
VILdiff(AC)	differential input low ac	Note 3	2 x (VIL(AC) - VREF)	Note 3	2 x (VIL(AC) - VREF)	Note 3	2 x (VIL(AC) - VREF)	V	2

Notes:

1. Used to define a differential signal slew-rate.
2. for CK_t - CK_c use VIH.CA/VIL.CA(AC) of ADD/CMD and VREFCA;
3. These values are not defined; however, the differential signals CK_t - CK_c, need to be within the respective limits (VIH.CA(DC) max, VIL.CA(DC) min) for single-ended signals as well as the limitations for overshoot and undershoot.



Table 77 – Allowed time before ring back (tDVAC) for CK_t - CK_c

Slew Rate [V/nS]	tDVAC [pS] @ VIH/Ldiff(AC) = 200mV	
	Min	Max
> 4.0	120	-
4.0	115	-
3.0	110	-
2.0	105	-
1.8	100	-
1.6	95	-
1.4	90	-
1.2	85	-
1.0	80	-
< 1.0	80	-

12.3.3 Single-ended requirements for differential signals (CK_t, CK_c)

Each individual component of a differential signal (CK_t, CK_c) has also to comply with certain requirements for single-ended signals.

CK_t and CK_c have to approximately reach VSEHmin / VSELmax (approximately equal to the ac-levels (VIH.CA(AC) / VIL.CA(AC)) for ADD/CMD signals) in every half-cycle.

Note that the applicable ac-levels for ADD/CMD might be different per speed-bin etc. E.g., if Different value than VIH.CA(AC100) / VIL.CA(AC100) is used for ADD/CMD signals, then these ac-levels apply also for the single-ended signals CK_t and CK_c

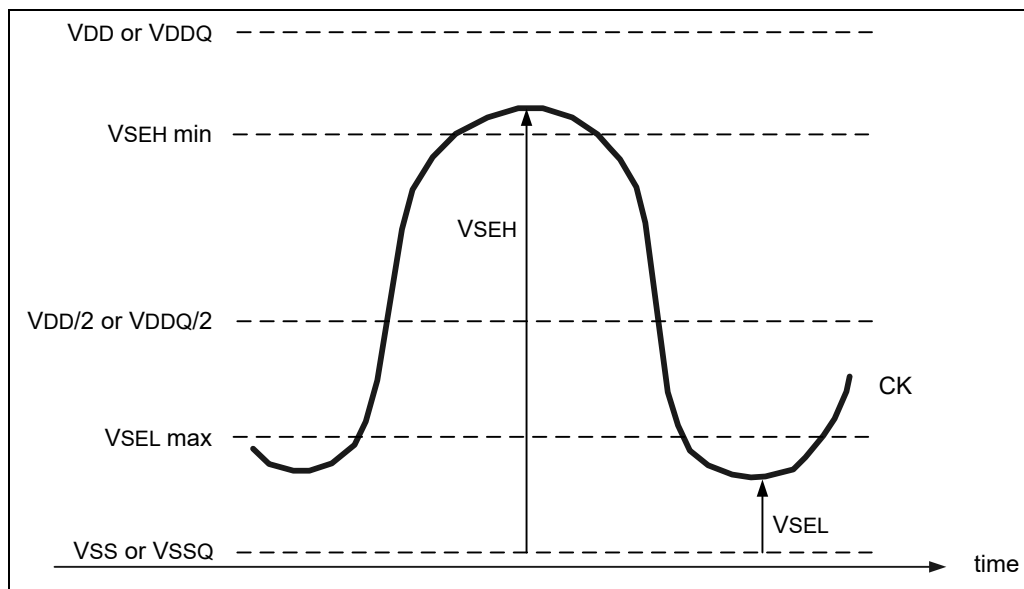

Figure 178 – Single-ended requirement for differential signals

Note that, while ADD/CMD signal requirements are with respect to VREFCA, the single-ended components of differential signals have a requirement with respect to VDD/2; this is nominally the same. The transition of single-ended signals through the ac-levels is used to measure setup time. For single-ended components of differential signals the requirement to reach VSELmax, VSEHmin has no bearing on timing, but adds a restriction on the common mode characteristics of these signals.



Table 78 – Single-ended levels for CK_t, CK_c

Symbol	Parameter	DDR4-1600/1866/2133		DDR4-2400/2666		DDR4-3200		Unit	Notes
		Min	Max	Min	Max	Min	Max		
VSEH	Single-ended high-level for CK_t-CK_c	(VDD/2) + 0.1	Note 3	(VDD/2) + 0.095	Note 3	(VDD/2) + 0.085	Note 3	V	1, 2
VSEL	Single-ended low-level for CK_t-CK_c	Note 3	(VDD/2) - 0.1	Note 3	(VDD/2) - 0.095	Note 3	(VDD/2) - 0.085	V	1, 2

Notes:

1. For CK_t - CK_c use VIH/VIL(AC) of ADD/CMD;
2. VIH(AC)/VIL(AC) for ADD/CMD is based on VREFCA;
3. These values are not defined, however the single-ended signals CK_t - CK_c need to be within the respective limits (VIH.CA(DC) max, VIL.CA(DC)min) for single-ended signals as well as the limitations for overshoot and undershoot.

12.3.4 Address, Command and Control Overshoot and Undershoot specifications

Table 79 – AC overshoot/undershoot specification for Address, Command and Control pins

Parameter	Symbol	Specification						Unit	Note
		DDR4-1600	DDR4-1866	DDR4-2133	DDR4-2400	DDR4-2666	DDR4-3200		
Maximum peak amplitude above VAOS	VAOSP	0.06						V	
Upper boundary of overshoot area AAOS1	VAOS	VDD + 0.24						V	1
Maximum peak amplitude allowed for undershoot	VAUS	0.30						V	
Maximum overshoot area per 1 tCK above VAOS	AAOS2	0.0083	0.0071	0.0062	0.0055		V-nS		
Maximum overshoot area per 1 tCK between VDD and VAOS	AAOS1	0.2550	0.2185	0.1914	0.1699		V-nS		
Maximum undershoot area per 1 tCK below VSS	AAUS	0.2644	0.2265	0.1984	0.1762		V-nS		

(A0-A13, BG0, BA0-BA1, ACT_n, RAS_n/A16, CAS_n/A15, WE_n/A14, CS_n, CKE, ODT)

Note:

1. The value of VAOS matches VDD absolute max as defined in Table 73 Absolute Maximum DC Ratings if VDD equals VDD max as defined in Table 74 Recommended DC Operating Conditions. If VDD is above the recommended operating conditions, VAOS remains at VDD absolute max as defined in Table 73.

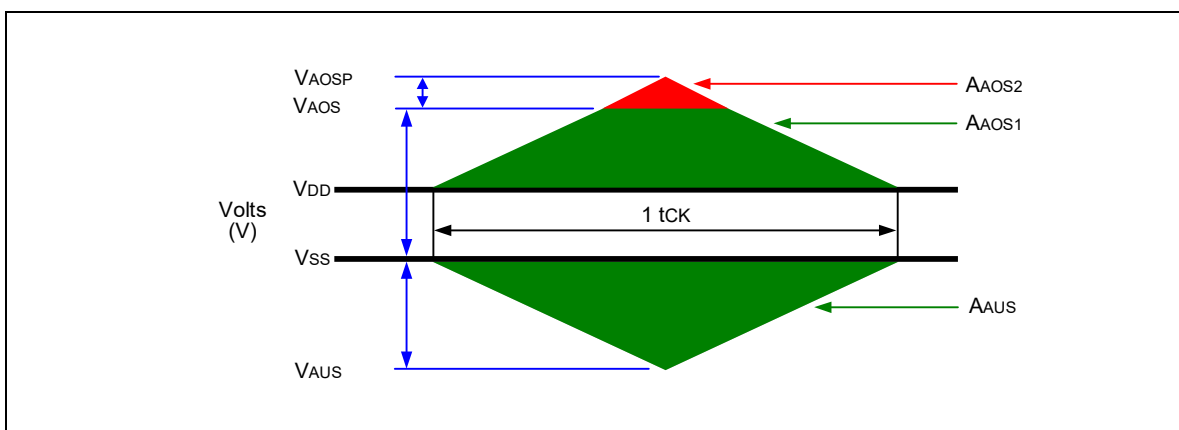

Figure 179 – Address, Command and Control Overshoot and Undershoot Definition



12.3.5 Clock Overshoot and Undershoot Specifications

Table 80 – AC overshoot/undershoot specification for Clock

Parameter	Symbol	Specification						Unit	Note
		DDR4-1600	DDR4-1866	DDR4-2133	DDR4-2400	DDR4-2666	DDR4-3200		
Maximum peak amplitude above VCOS	VCOSP	0.06						V	
Upper boundary of overshoot area ADOS1	VCOS	VDD + 0.24						V	1
Maximum peak amplitude allowed for undershoot	VCUS	0.3						V	
Maximum overshoot area per 1 UI above VCOS	ACOS2	0.0038	0.0032	0.0028	0.0025		V-nS		
Maximum overshoot area per 1 UI between VDD and VDOS	ACOS1	0.1125	0.0964	0.0844	0.075		V-nS		
Maximum undershoot area per 1 UI below VSS	ACUS	0.1144	0.098	0.0858	0.0762		V-nS		

(CK_t, CK_c)

Note:

- The value of VCOS matches VDD absolute max as defined in Table 73 Absolute Maximum DC Ratings if VDD equals VDD max as defined in Table 74 Recommended DC Operating Conditions. If VDD is above the recommended operating conditions, VCOS remains at VDD absolute max as defined in Table 73.

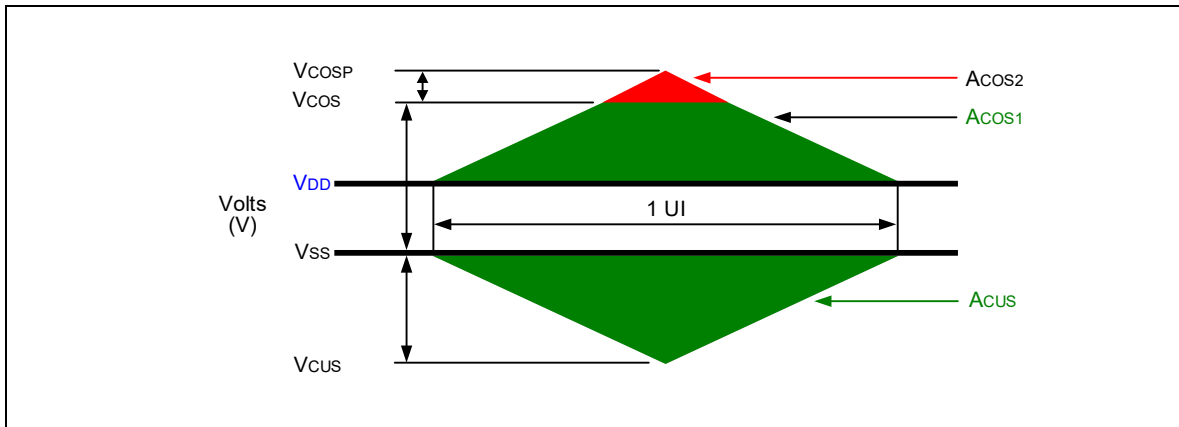

Figure 180 – Clock Overshoot and Undershoot Definition



12.3.6 Data, Strobe and Mask Overshoot and Undershoot Specifications

Table 81 – AC overshoot/undershoot specification for Data, Strobe and Mask

Parameter	Symbol	Specification						Unit	Note
		DDR4-1600	DDR4-1866	DDR4-2133	DDR4-2400	DDR4-2666	DDR4-3200		
Maximum peak amplitude above VDOS	VDOSP	0.16						V	
Upper boundary of overshoot area ADOS1	VDOS	VDDQ + 0.24						V	1
Lower boundary of undershoot area ADUS1	VDUS	0.3						V	2
Maximum peak amplitude below VDUS	VDUSP	0.1						V	
Maximum overshoot area per 1 UI above VDOS	ADOS2	0.015	0.0129	0.0113	0.01		V-nS		
Maximum overshoot area per 1 UI between VDDQ and VDOS	ADOS1	0.105	0.09	0.0788	0.07		V-nS		
Maximum undershoot area per 1 UI between VSSQ and VDUS1	ADUS1	0.105	0.09	0.0788	0.07		V-nS		
Maximum undershoot area per 1 UI below VDUS	ADUS2	0.015	0.0129	0.0113	0.01		V-nS		

(DQU0-DQU7, DQL0-DQL7, DQSU_t, DQSU_c, DQSL_t, DQSL_c, DML_n/DBIL_n, DMU_n/DBIU_n)

Notes:

- The value of VDOS matches (VIN, VOUT) max as defined in Table 73 Absolute Maximum DC Ratings if VDDQ equals VDDQ max as defined in Table 74 Recommended DC Operating Conditions. If VDDQ is above the recommended operating conditions, VDOS remains at (VIN, VOUT) max as defined in Table 73.
- The value of VDUS matches (VIN, VOUT) min as defined in Table 73 Absolute Maximum DC Ratings.

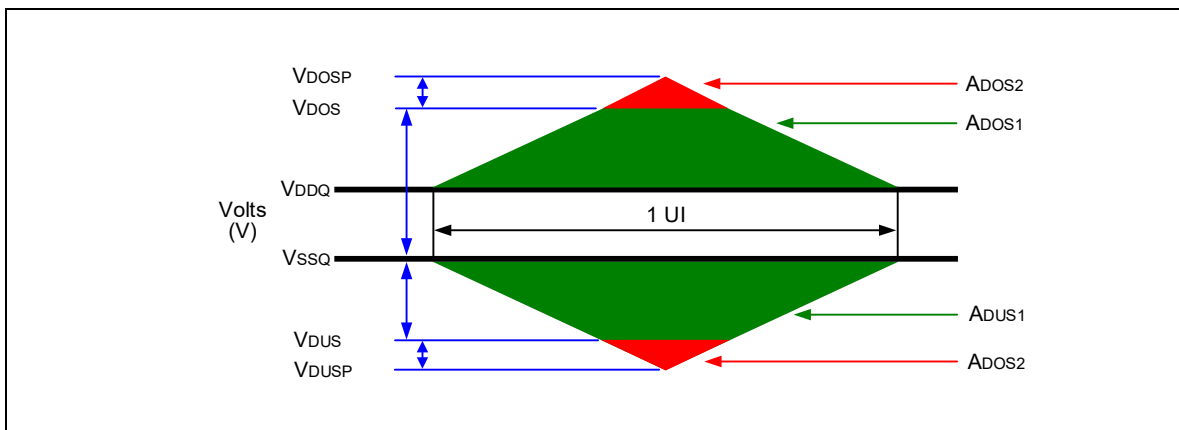

Figure 181 – Data, Strobe and Mask Overshoot and Undershoot Definition



12.4 Slew Rate Definitions

12.4.1 Slew Rate Definitions for Differential Input Signals (CK)

Input slew rate for differential signals (CK_t, CK_c) are defined and measured as shown in Table 82 and Figure 182.

Table 82 – Differential Input Slew Rate Definition

Description	from	to	Defined by
Differential input slew rate for rising edge(CK _t - CK _c)	V _{ILdiffmax}	V _{IHdiffmin}	$[V_{IHdiffmin} - V_{ILdiffmax}] / \Delta TR_{diff}$
Differential input slew rate for falling edge(CK _t - CK _c)	V _{IHdiffmin}	V _{ILdiffmax}	$[V_{IHdiffmin} - V_{ILdiffmax}] / \Delta TF_{diff}$

Note: The differential signal CK_t, CK_c must be linear between these thresholds.

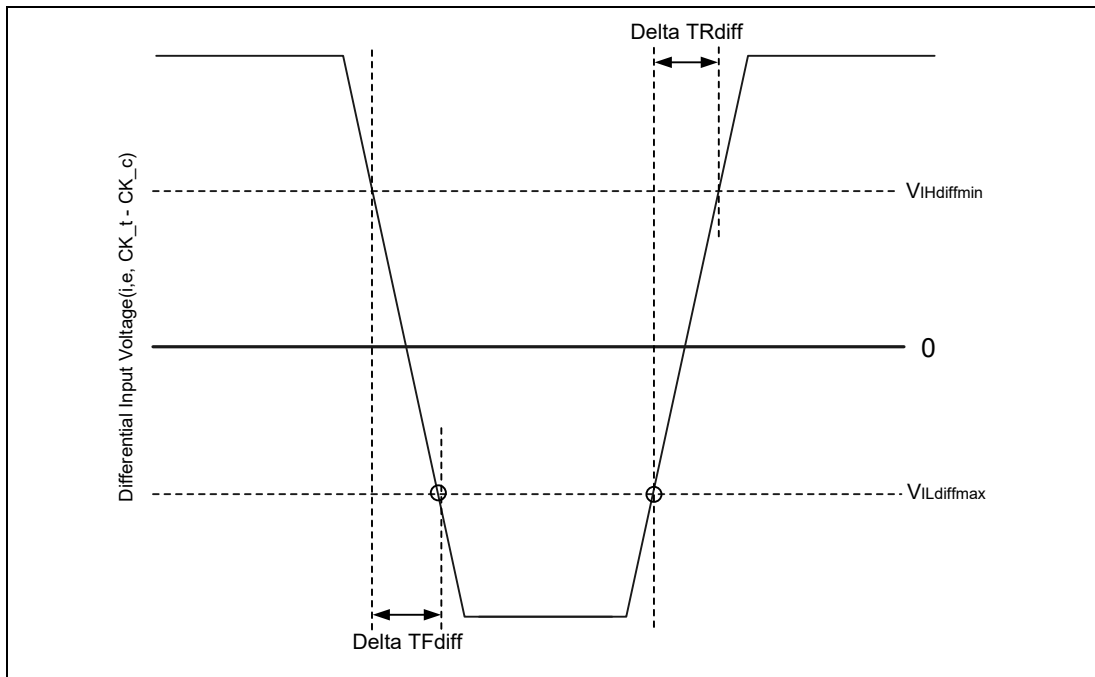
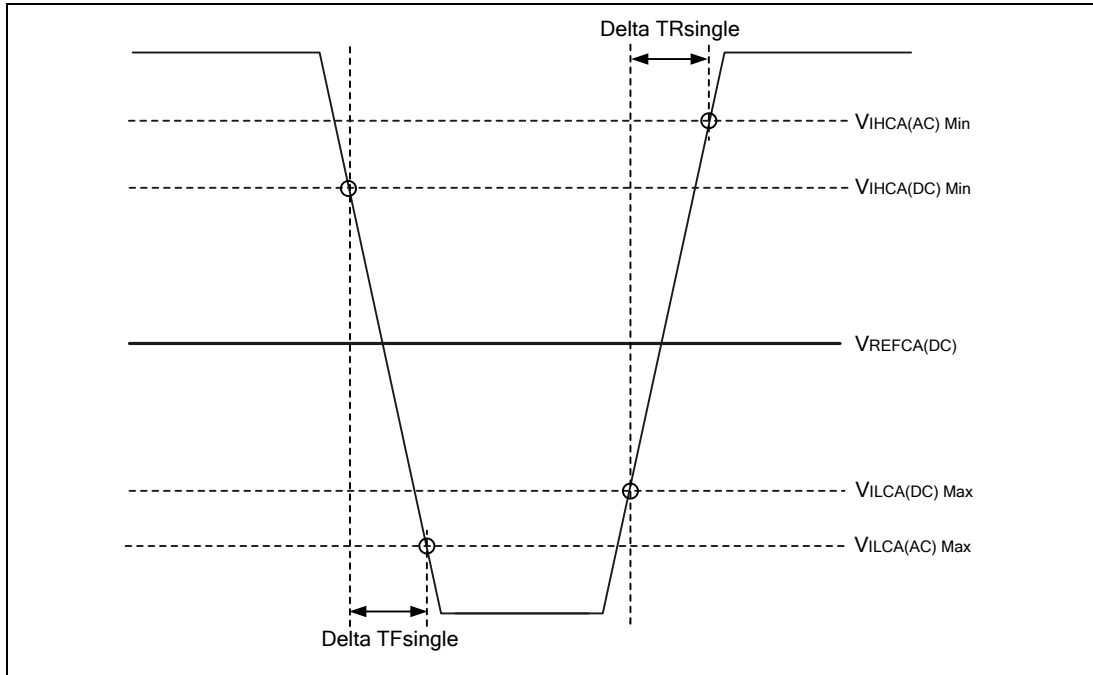

Figure 182 – Differential Input Slew Rate Definition for CK_t, CK_c



12.4.2 Slew Rate Definition for Single-ended Input Signals (CMD/ADD)



Notes:

1. Single-ended input slew rate for rising edge = { VIHCA(AC)Min - VILCA(DC)Max } / Delta TR single.
2. Single-ended input slew rate for falling edge = { VIHCA(DC)Min - VILCA(AC)Max } / Delta TF single.
3. Single-ended signal rising edge from VILCA(DC)Max to VIHCA(DC)Min must be monotonic slope.
4. Single-ended signal falling edge from VIHCA(DC)Min to VILCA(DC)Max must be monotonic slope.

Figure 183 – Single-ended Input Slew Rate definition for CMD and ADD

12.5 Differential Input Cross Point Voltage (CK)

To guarantee tight setup and hold times as well as output skew parameters with respect to clock, each cross point voltage of differential input signals (CK_t, CK_c) must meet the requirements in Table 83. The differential input cross point voltage Vix is measured from the actual cross point of true and complement signals to the midlevel between of VDD and VSS.

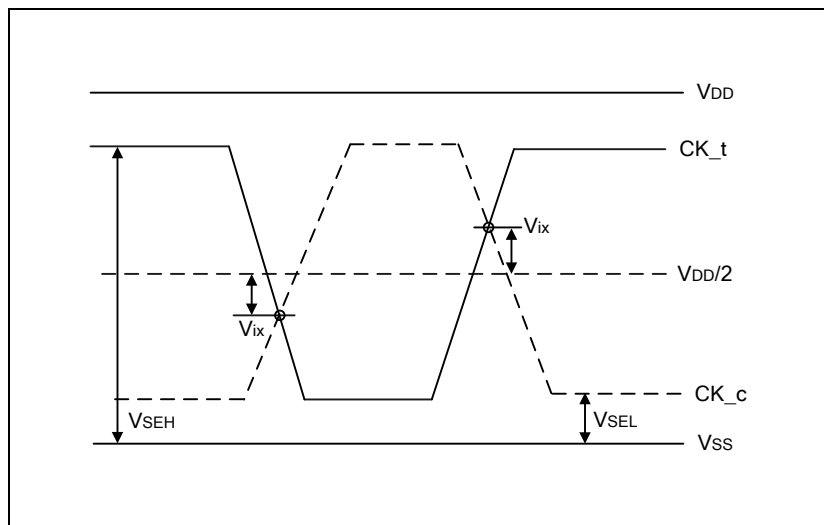

Figure 184 – Vix Definition (CK)



Table 83-1 – Cross point voltage for differential input signals (CK) at DDR4-1600/1866/2133/2400

Symbol	Parameter	Input Level	DDR4-1600/1866/2133/2400	
			Min	Max
VIX(CK)	Differential Input Cross Point Voltage relative to VDD/2 for CK_t, CK_c	$VDD/2 + 145\text{ mV} < VSEH$	-	120 mV
		$VDD/2 + 100\text{ mV} \leq VSEH \leq VDD/2 + 145\text{ mV}$	-	$(VSEH - VDD/2) - 25\text{ mV}$
		$VDD/2 - 145\text{ mV} \leq VSEL \leq VDD/2 - 100\text{ mV}$	$-(VDD/2 - VSEL) + 25\text{ mV}$	-
		$VSEL < VDD/2 - 145\text{ mV}$	-120 mV	-

Table 83-2 – Cross point voltage for differential input signals (CK) at DDR4-2666/3200

Symbol	Parameter	Input Level	DDR4-2666/3200	
			Min	Max
VIX(CK)	Differential Input Cross Point Voltage relative to VDD/2 for CK_t, CK_c	$VDD/2 + 145\text{ mV} < VSEH$	-	110 mV
		$VDD/2 + 100\text{ mV} \leq VSEH \leq VDD/2 + 145\text{ mV}$	-	$(VSEH - VDD/2) - 30\text{ mV}$
		$VDD/2 - 145\text{ mV} \leq VSEL \leq VDD/2 - 100\text{ mV}$	$-(VDD/2 - VSEL) + 30\text{ mV}$	-
		$VSEL < VDD/2 - 145\text{ mV}$	-110 mV	-

12.6 CMOS rail to rail Input Levels

12.6.1 CMOS rail to rail Input Levels for RESET_n

Table 84 – CMOS rail to rail Input Levels for RESET_n

Parameter	Symbol	Min	Max	Unit	Notes
AC Input High Voltage	VIH(AC)_RESET	0.8*VDD	VDD	V	6
DC Input High Voltage	VIH(DC)_RESET	0.7*VDD	VDD	V	2
DC Input Low Voltage	VIL(DC)_RESET	VSS	0.3*VDD	V	1
AC Input Low Voltage	VIL(AC)_RESET	VSS	0.2*VDD	V	7
Rising time	TR_RESET	-	1.0	μS	4
RESET pulse width	tPW_RESET	1.0	-	μS	3, 5

Notes:

1. After RESET_n is registered LOW, RESET_n level shall be maintained below VIL(DC)_RESET during tPW_RESET, otherwise, SDRAM may not be reset.
2. Once RESET_n is registered HIGH, RESET_n level must be maintained above VIH(DC)_RESET, otherwise, SDRAM operation will not be guaranteed until it is reset asserting RESET_n signal LOW.
3. RESET is destructive to data contents.
4. No slope reversal (ring back) requirement during its level transition from Low to High.
5. This definition is applied only “Reset Procedure at Power Stable”.
6. Overshoot might occur. It should be limited by the Absolute Maximum DC Ratings.
7. Undershoot might occur. It should be limited by Absolute Maximum DC Ratings.

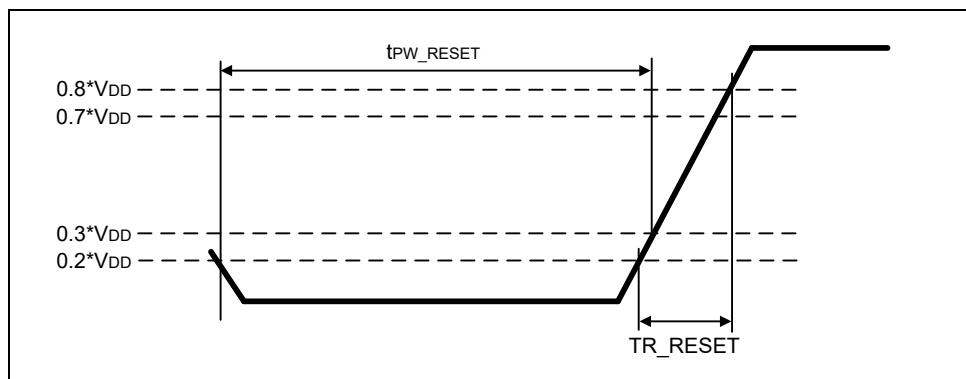

Figure 185 – RESET_n Input Slew Rate Definition



12.7 AC and DC Logic Input Levels for DQS Signals

12.7.1 Differential signal definition

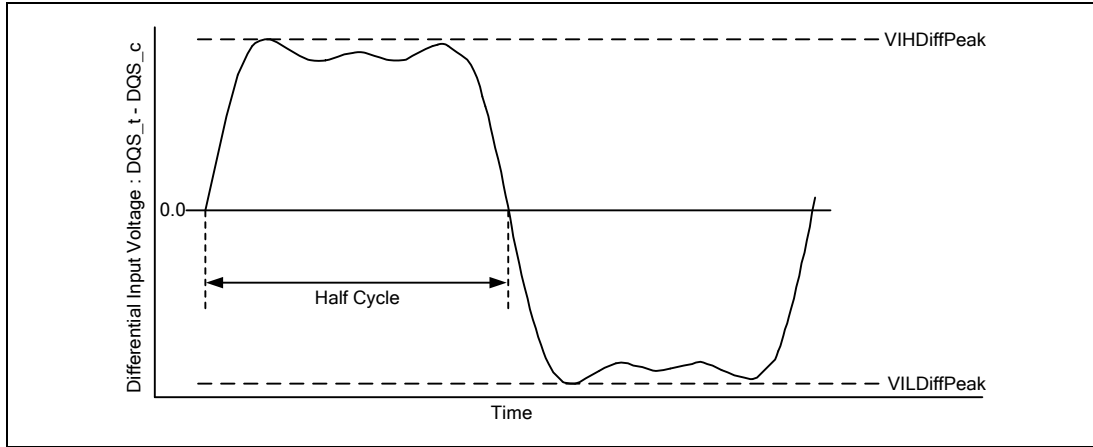

Figure 186 – Definition of differential DQS Signal AC-swing Level

12.7.2 Differential swing requirements for DQS (DQS_t - DQS_c)

Table 85 – Differential swing requirements for DQS (DQS_t - DQS_c)

Symbol	Parameter	DDR4-1600, 1866, 2133		DDR4-2400		DDR4-2666		DDR4-3200		Unit	Note
		Min	Max	Min	Max	Min	Max	Min	Max		
VIHDiffPeak	VIH.DIFF.Peak Voltage	186	Note 2	160	Note 2	150	Note 2	140	Note 2	mV	1, 2
VILDiffPeak	VIL.DIFF.Peak Voltage	Note 2	-186	Note 2	-160	Note 2	-150	Note 2	-140	mV	1, 2

Notes:

- Used to define a differential signal slew-rate.
- These values are not defined; however, the differential signals DQS_t - DQS_c, need to be within the respective limits Overshoot, Undershoot Specification for single-ended signals.

12.7.3 Peak voltage calculation method

The peak voltage of Differential DQS signals are calculated in a following equation.

$$VIH.DIFF.Peak Voltage = \text{Max}(f(t))$$

$$VIL.DIFF.Peak Voltage = \text{Min}(f(t))$$

$$f(t) = VDQS_t - VDQS_c$$

The Max(f(t)) or Min(f(t)) used to determine the midpoint which to reference the ±35% window of the exempt non-monotonic signaling shall be the smallest peak voltage observed in all UI's.

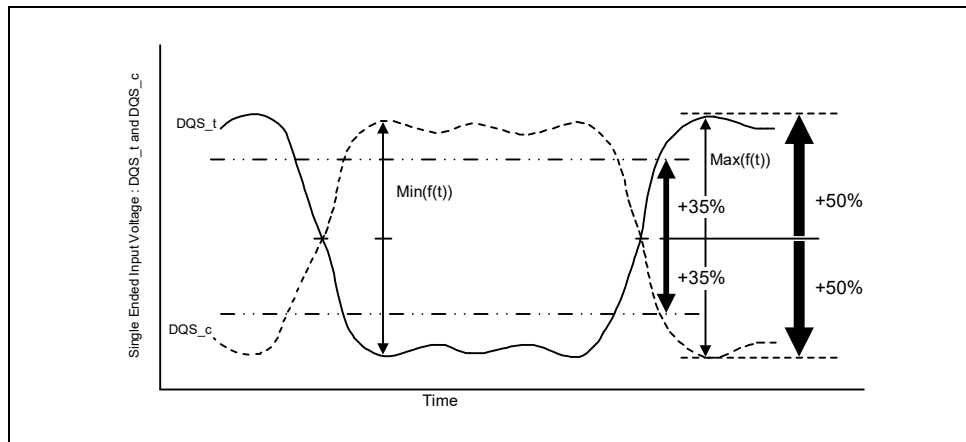

Figure 187 – Definition of differential DQS Peak Voltage and rage of exempt non-monotonic signaling



12.7.4 Differential Input Cross Point Voltage (DQS)

To achieve tight RxMask input requirements as well as output skew parameters with respect to strobe, the cross point voltage of differential input signals (DQS_t, DQS_c) must meet the requirements in Table 86. The differential input cross point voltage VIX_DQS (VIX_DQS_FR and VIX_DQS_RF) is measured from the actual cross point of DQS_t, DQS_c relative to the VDQSmid of the DQS_t and DQS_c signals.

VDQSmid is the midpoint of the minimum levels achieved by the transitioning DQS_t and DQS_c signals, and noted by VDQS_trans. VDQS_trans is the difference between the lowest horizontal tangent above VDQSmid of the transitioning DQS signals and the highest horizontal tangent below VDQSmid of the transitioning DQS signals.

A non-monotonic transitioning signal's ledge is exempt or not used in determination of a horizontal tangent provided the said ledge occurs within $\pm 35\%$ of the midpoint of either VIH.DIFF.Peak Voltage (DQS_t rising) or VIL.DIFF.Peak Voltage (DQS_c rising), refer to Figure 187 A secondary horizontal tangent resulting from a ring-back transition is also exempt in determination of a horizontal tangent. That is, a falling transition's horizontal tangent is derived from its negative slope to zero slope transition (point A in Figure 188 and a ring-back's horizontal tangent derived from its positive slope to zero slope transition (point B in Figure 188 is not a valid horizontal tangent; and a rising transition's horizontal tangent is derived from its positive slope to zero slope transition (point C in Figure 188 and a ring-back's horizontal tangent derived from its negative slope to zero slope transition (point D in Figure 188 is not a valid horizontal tangent).

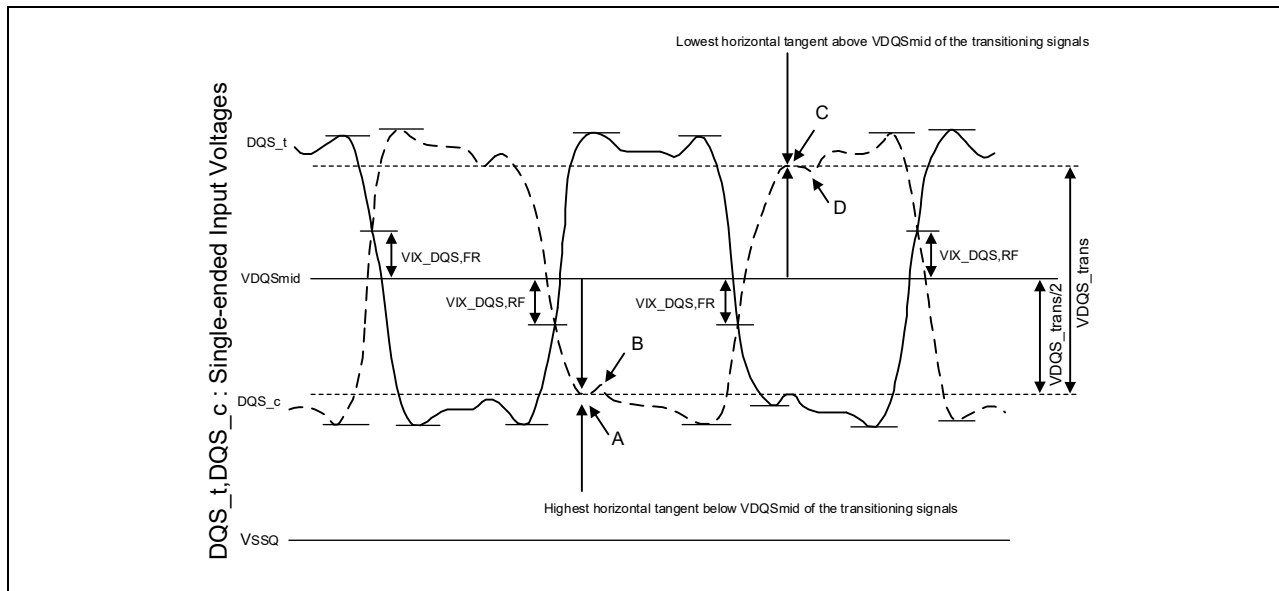

Figure 188 – Vix Definition (DQS)

Table 86 – Cross point voltage for differential input signals (DQS)

Parameter	Symbol	DDR4-1600, DDR4-1866, 2133, 2400, 2666, 3200		Unit	Notes
		Min	Max		
Vix_DQS_ratio	DQS_t and DQS_c crossing relative to the midpoint of the DQS_t and DQS_c signal swings	-	25	%	1,2
VDQSmid_to_Vcent	VDQSmid offset relative to Vcent_DQ(midpoint)	-	min(VIHdiff,50)	mV	3, 4, 5

Notes:

- Vix_DQS_Ratio is DQS VIX crossing (Vix_DQS_FR or Vix_DQS_RF) divided by VDQS_trans. VDQS_trans is the difference between the lowest horizontal tangent above VDQSmid of the transitioning DQS signals and the highest horizontal tangent below VDQSmid of the transitioning DQS signals.
- VDQSmid will be similar to the VREFDQ internal setting value obtained during VREF Training if the DQS and DQs drivers and paths are matched.
- The maximum limit shall not exceed the smaller of VIHdiff minimum limit or 50mV.
- VIX measurements are only applicable for transitioning DQS_t and DQS_c signals when toggling data, preamble and Hi-z states are not applicable conditions.
- The parameter VDQSmid is defined for simulation and ATE testing purposes, it is not expected to be tested in a system.



12.7.5 Differential Input Slew Rate Definition

Input slew rate for differential signals (DQS_t, DQS_c) are defined and measured as shown in Figure 188 and Figure 189

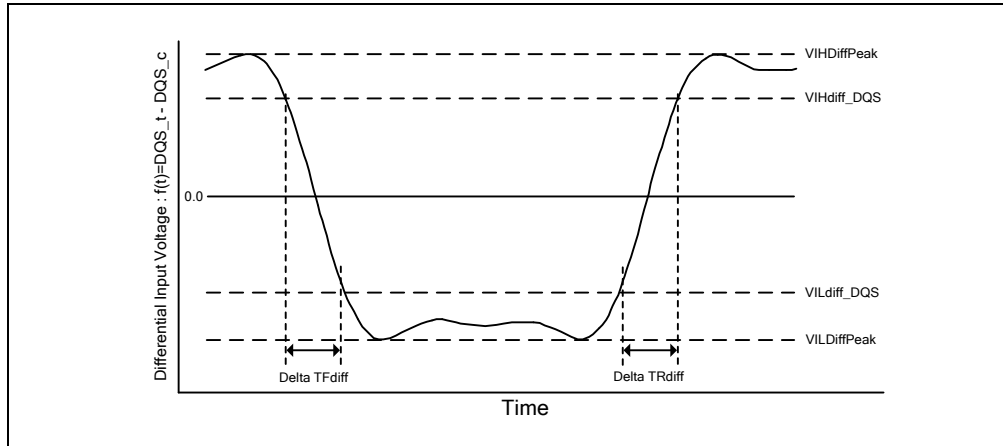

Notes:

1. Differential signal rising edge from VILdiff_DQS to VIHdiff_DQS must be monotonic slope.
2. Differential signal falling edge from VIHdiff_DQS to VILdiff_DQS must be monotonic slope.

Figure 189 – Differential Input Slew Rate Definition for DQS_t, DQS_c

Table 87 – Differential Input Slew Rate Definition for DQS_t, DQS_c

Description	from	to	Defined by
Differential input slew rate for rising edge(DQS_t - DQS_c)	VILdiff_DQS	VIHdiff_DQS	$ VILdiff_DQS - VIHdiff_DQS /DeltaTRdiff$
Differential input slew rate for falling edge(DQS_t - DQS_c)	VIHdiff_DQS	VILdiff_DQS	$ VILdiff_DQS - VIHdiff_DQS /DeltaTFdiff$

Table 88 – Differential Input Level for DQS_t, DQS_c

Symbol	Parameter	DDR4-1600, 1866, 2133		DDR4-2400, 2666		DDR4-3200		Unit	Note
		Min	Max	Min	Max	Min	Max		
VIHdiff_DQS	Differential Input High	136	-	130	-	110	-	mV	
VILdiff_DQS	Differential Input Low	-	-136	-	-130	-	-110	mV	

Table 89 – Differential Input Slew Rate for DQS_t, DQS_c

Symbol	Parameter	DDR4-1600, 1866, 2133		DDR4-2400		DDR4-2666, 3200		Unit	Note
		Min	Max	Min	Max	Min	Max		
SRIdiff	Differential Input Slew Rate	3	18	3	18	2.5	18	V/nS	



13. AC and DC Output Measurement Levels

13.1 Output Driver DC Electrical Characteristics

The DDR4 driver supports two different Ron values. These Ron values are referred as strong (low Ron) and weak mode (high Ron). A functional representation of the output buffer is shown in the figure below. Output driver impedance RON is defined as follows:

The individual pull-up and pull-down resistors (RONpu and RONpd) are defined as follows:

$$RON_{pu} = \frac{VDDQ - V_{out}}{|I_{out}|} \quad \text{under the condition that } RON_{pd} \text{ is off}$$

$$RON_{pd} = \frac{V_{out}}{|I_{out}|} \quad \text{under the condition that } RON_{pu} \text{ is off}$$

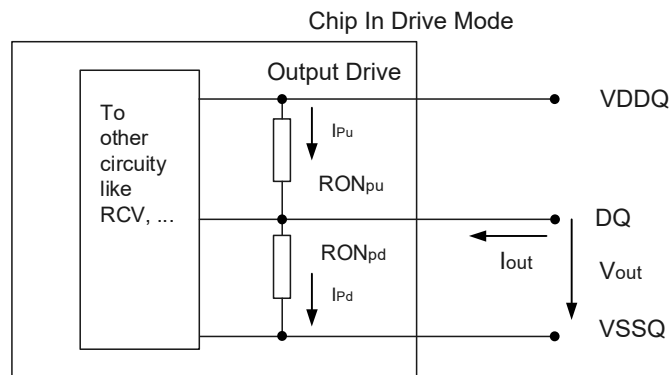

Figure 190 – Output driver



Table 90 – Output Driver DC Electrical Characteristics, assuming RZQ = 240ohm; entire operating temperature range; after proper ZQ calibration

RON _{NOM}	Resistor	Vout	Min	Nom	Max	Unit	Notes
34Ω	RON34Pd	VOLdc= 0.5*VDDQ	0.73	1	1.1	RZQ/7	1, 2, 6
		VOMdc= 0.8* VDDQ	0.83	1	1.1	RZQ/7	1, 2, 6
		VOHdc= 1.1* VDDQ	0.83	1	1.25	RZQ/7	1, 2, 6
	RON34Pu	VOLdc= 0.5*VDDQ	0.9	1	1.25	RZQ/7	1, 2, 6
		VOMdc= 0.8* VDDQ	0.9	1	1.1	RZQ/7	1, 2, 6
		VOHdc= 1.1* VDDQ	0.8	1	1.1	RZQ/7	1, 2, 6
48Ω	RON48Pd	VOLdc= 0.5*VDDQ	0.73	1	1.1	RZQ/5	1, 2, 6
		VOMdc= 0.8* VDDQ	0.83	1	1.1	RZQ/5	1, 2, 6
		VOHdc= 1.1* VDDQ	0.83	1	1.25	RZQ/5	1, 2, 6
	RON48Pu	VOLdc= 0.5*VDDQ	0.9	1	1.25	RZQ/5	1, 2, 6
		VOMdc= 0.8* VDDQ	0.9	1	1.1	RZQ/5	1, 2, 6
		VOHdc= 1.1* VDDQ	0.8	1	1.1	RZQ/5	1, 2, 6
Mismatch between pull-up and pull-down, MMPuPd		VOMdc= 0.8* VDDQ	-10		17	%	1, 2, 4, 3
Mismatch DQ-DQ within byte variation pull-up, MMPuDD		VOMdc= 0.8* VDDQ			10	%	1, 2, 4
Mismatch DQ-DQ within byte variation pull-down, MMPddd		VOMdc= 0.8* VDDQ			10	%	1, 2, 4

Notes :

- The tolerance limits are specified after calibration with stable voltage and temperature. For the behavior of the tolerance limits if temperature or voltage changes after calibration, see following section on voltage and temperature sensitivity.
- Pull-up and pull-down output driver impedances are recommended to be calibrated at 0.8 * VDDQ. Other calibration schemes may be used to achieve the linearity spec shown above, e.g. calibration at 0.5 * VDDQ and 1.1 * VDDQ.
- Measurement definition for mismatch between pull-up and pull-down, MMPuPd: Measure RONPu and RONPd both at 0.8*VDD separately; Ronnom is the nominal Ron value.

$$MMPuPd = \frac{RONPu - RONPd}{RONNOM} * 100$$

- RON variance range ratio to RON Nominal value in a given component, including DQS_t and DQS_c.

$$MMPuDD = \frac{RONPuMax - RONPuMin}{RONNOM} * 100$$

$$MMPddd = \frac{RONPdMax - RONPdMin}{RONNOM} * 100$$

- This parameter of x16 device is specified for Upper byte and Lower byte.
- For Industrial/Industrial plus grade parts device, the minimum values are reduced by 9%.



13.1.1 Alert_n Output Drive Characteristic

A functional representation of the output buffer is shown in the figure below. Output driver impedance RON is defined as follows:

$$RON_{Pd} = \frac{V_{out}}{|I_{out}|} \text{ under the condition that } RON_{Pu} \text{ is off}$$

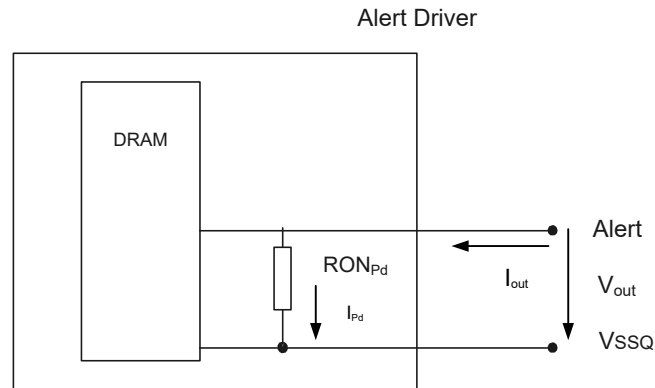

Resistor	Vout	Min	Max	Unit	Note
RONPd	VOLdc = 0.1 * VDDQ	0.3	1.2	34Ω	1
	VOMdc = 0.8 * VDDQ	0.4	1.2	34Ω	1
	VOHdc = 1.1 * VDDQ	0.4	1.4	34Ω	1

Note:

- 1. VDDQ voltage is at VDDQ DC.



13.1.2 Output Driver Characteristic of Connectivity Test (CT) Mode

Following Output driver impedance RON will be applied Test Output Pin during Connectivity Test (CT) Mode. The individual pull-up and pull-down resistors (RONPu_CT and RONPd_CT) are defined as follows:

$$RON_{Pu_CT} = \frac{V_{DDQ} - V_{OUT}}{|I_{out}|}$$

$$RON_{Pd_CT} = \frac{V_{OUT}}{|I_{out}|}$$

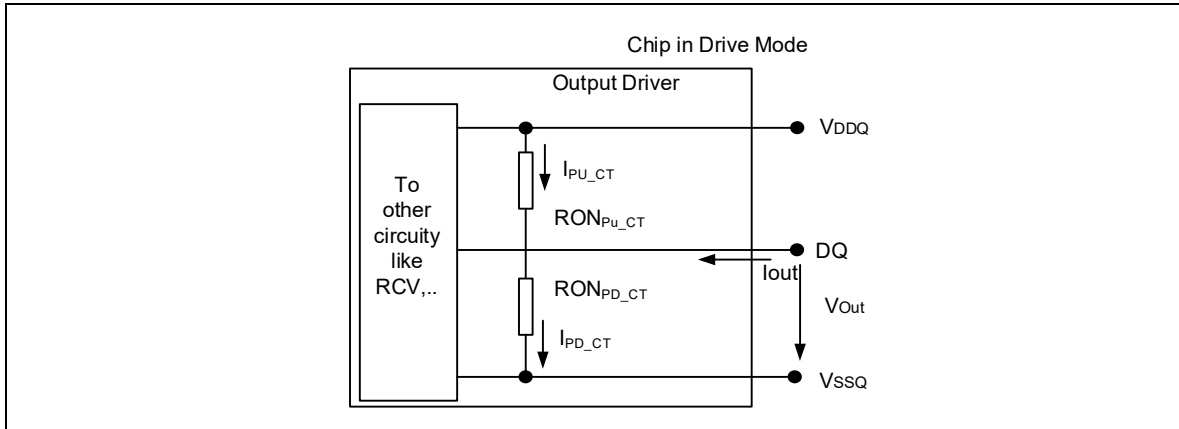

RON _{NOM_CT}	Resistor	Vout	Max	Units	Note
34Ω	RON _{Pd_CT}	VOB _{dc} = 0.2* VDDQ	1.9	34Ω	1
		VOL _{dc} = 0.5* VDDQ	2.0	34Ω	1
		VOM _{dc} = 0.8* VDDQ	2.2	34Ω	1
		VOH _{dc} = 1.1* VDDQ	2.5	34Ω	1
	RON _{Pu_CT}	VOB _{dc} = 0.2* VDDQ	2.5	34Ω	1
		VOL _{dc} = 0.5* VDDQ	2.2	34Ω	1
		VOM _{dc} = 0.8* VDDQ	2.0	34Ω	1
		VOH _{dc} = 1.1* VDDQ	1.9	34Ω	1

Note:

1. Connectivity test mode uses un-calibrated drivers, showing the full range over PVT. No mismatch between pull up and pull down is defined.

13.2 Single-ended AC & DC Output Levels

Table 91 – Single-ended AC & DC output levels

Symbol	Parameter	DDR4-1600/1866/2133/2400/2666/3200	Units	Note
VOH(DC)	DC output high measurement level (for IV curve linearity)	1.1 x VDDQ	V	
VOM(DC)	DC output mid measurement level (for IV curve linearity)	0.8 x VDDQ	V	
VOL(DC)	DC output low measurement level (for IV curve linearity)	0.5 x VDDQ	V	
VOH(AC)	AC output high measurement level (for output SR)	(0.7 + 0.15) x VDDQ	V	1
VOL(AC)	AC output low measurement level (for output SR)	(0.7 - 0.15) x VDDQ	V	1

Note:

1. The swing of ± 0.15 x VDDQ is based on approximately 50% of the static single-ended output peak-to-peak swing with a driver impedance of RZQ/7Ω and an effective test load of 50Ω to VTT = VDDQ.



13.3 Differential AC & DC Output Levels

Table 92 – Differential AC & DC output levels

Symbol	Parameter	DDR4-1600/1866/2133/2400/2666/3200	Units	Note
VOHdiff(AC)	AC differential output high measurement level (for output SR)	+0.3 x VDDQ	V	1
VOLdiff(AC)	AC differential output low measurement level (for output SR)	-0.3 x VDDQ	V	1

Note:

1. The swing of $\pm 0.3 \times VDDQ$ is based on approximately 50% of the static differential output peak-to-peak swing with a driver impedance of $RZQ/7\Omega$ and an effective test load of 50Ω to $VTT = VDDQ$ at each of the differential outputs.

13.4 Single-ended Output Slew Rate

With the reference load for timing measurements, output slew rate for falling and rising edges is defined and measured between VOL(AC) and VOH(AC) for single ended signals as shown in Table 93 and Figure 191

Table 93 – Single-ended output slew rate definition

Description	Measured		Defined by
	from	to	
Single ended output slew rate for rising edge	VOL(AC)	VOH(AC)	$[VOH(AC) - VOL(AC)] / \Delta TRse$
Single ended output slew rate for falling edge	VOH(AC)	VOL(AC)	$[VOH(AC) - VOL(AC)] / \Delta TFse$

Note:

1. Output slew rate is verified by design and characterization, and may not be subject to production test.

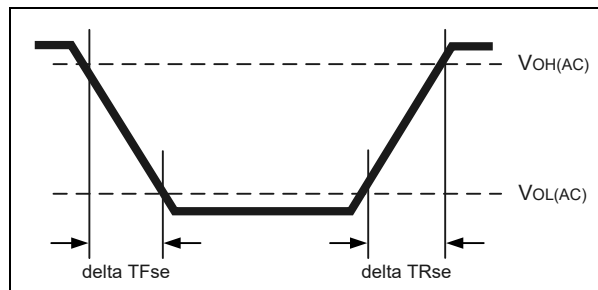

Figure 191 – Single-ended Output Slew Rate Definition

Table 94 – Single-ended output slew rate

Parameter	Symbol	DDR4-1600		DDR4-1866		DDR4-2133		DDR4-2400		DDR4-2666		DDR4-3200		Units
		Min	Max	Min	Max	Min	Max	Min	Max	Min	Max	Min	Max	
Single ended output slew rate	SRQse	4	9	4	9	4	9	4	9	4	9	4	9	V/nS

Description:

SR: Slew Rate

Q: Query Output (like in DQ, which stands for Data-in, Query-Output)

se: Single-ended Signals

For Ron = RZQ/7 setting

Note:

In two cases, a maximum slew rate of 12 V/nS applies for a single DQ signal within a byte lane.

- Case 1 is defined for a single DQ signal within a byte lane which is switching into a certain direction (either from high to low or low to high) while all remaining DQ signals in the same byte lane are static (i.e. they stay at either high or low).
- Case 2 is defined for a single DQ signal within a byte lane which is switching into a certain direction (either from high to low or low to high) while all remaining DQ signals in the same byte lane are switching into the opposite direction (i.e. from low to high or high to low respectively). For the remaining DQ signal switching into the opposite direction, the regular maximum limit of 9 V/nS applies.



13.5 Differential Output Slew Rate

With the reference load for timing measurements, output slew rate for falling and rising edges is defined and measured between VOLdiff(AC) and VOHdiff(AC) for differential signals as shown in Table 95 and Figure 192

Table 95 – Differential output slew rate definition

Description	Measured		Defined by
	from	to	
Differential output slew rate for rising edge	VOHdiff(AC)	VOHdiff(AC)	$[VOHdiff(AC) - VOLdiff(AC)] / \Delta TRdiff$
Differential output slew rate for falling edge	VOHdiff(AC)	VOHdiff(AC)	$[VOHdiff(AC) - VOLdiff(AC)] / \Delta TFdiff$

Note:

- Output slew rate is verified by design and characterization, and may not be subject to production test.

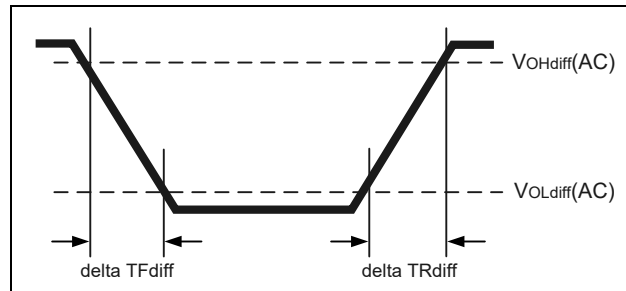

Figure 192 – Differential Output Slew Rate Definition

Table 96 – Differential output slew rate

Parameter	Symbol	DDR4-1600		DDR4-1866		DDR4-2133		DDR4-2400		DDR4-2666		DDR4-3200		Units
		Min	Max	Min	Max	Min	Max	Min	Max	Min	Max	Min	Max	
Differential output slew rate	SRQdiff	8	18	8	18	8	18	8	18	8	18	8	18	V/nS

Description:

SR: Slew Rate

Q: Query Output (like in DQ, which stands for Data-in, Query-Output)

diff: Differential Signals

For Ron = RZQ/7 setting



13.6 Single-ended AC and DC Output Levels of Connectivity Test Mode

Following output parameters will be applied for DDR4 SDRAM Output Signal during Connectivity Test Mode.

Table 97 – Single-ended AC & DC output levels of Connectivity Test Mode

Symbol	Parameter	DDR4-1600/1866/2133/2400/2666/3200	Units	Note
VOH(DC)	DC output high measurement level (for IV curve linearity)	1.1 x VDDQ	V	
VOM(DC)	DC output mid measurement level (for IV curve linearity)	0.8 x VDDQ	V	
VOL(DC)	DC output low measurement level (for IV curve linearity)	0.5 x VDDQ	V	
VOB(DC)	DC output below measurement level (for IV curve linearity)	0.2 x VDDQ	V	
VOH(AC)	AC output high measurement level (for output SR)	VTT + (0.1 x VDDQ)	V	1
VOL(AC)	AC output below measurement level (for output SR)	VTT - (0.1 x VDDQ)	V	1

Note:

- The effective test load is 50Ω terminated by VTT = 0.5 * VDDQ.

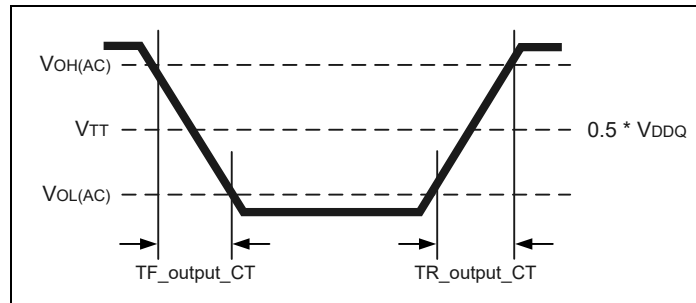

Figure 193 – Output Slew Rate Definition of Connectivity Test Mode

Table 98 – Single-ended output slew rate of Connectivity Test Mode

Symbol	Parameter	DDR4-1600/1866/2133/2400/2666/3200		Unit	Notes
		Min	Max		
TF_output_CT	Output signal Falling time	-	10	nS/V	
TR_output_CT	Output signal Rising time	-	10	nS/V	

13.7 Test Load for Connectivity Test Mode Timing

The reference load for Connectivity Test Mode timings is defined in Figure 194.

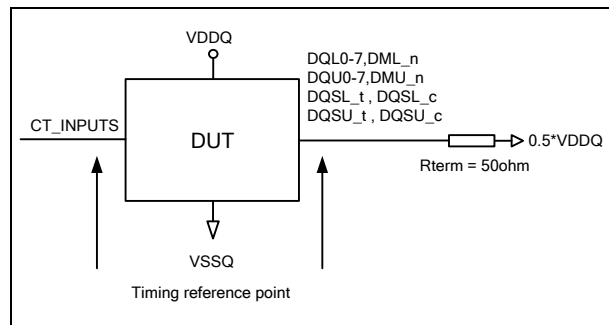

Figure 194 – Connectivity Test Mode Timing Reference Load



14. Speed Bins

Table 99 – DDR4-1600 Speed Bin and Operations

Speed Bin			DDR4-1600		Unit	Notes	
CL-nRCD-nRP			11-11-11				
Parameter		Symbol	Min.	Max.			
Internal read command to first data		tAA	13.75 ^{*13} (13.50) ^{*4,11}	18.00	nS	11	
Internal read command to first data with read DBI enabled		tAA_DBI	tAA(min) + 2nCK	tAA(max) + 2nCK	nS	11	
ACT to internal read or write delay time		tRCD	13.75 ^{*13} (13.50) ^{*4,11}	-	nS	11	
PRE command period		tRP	13.75 ^{*13} (13.50) ^{*4,11}	-	nS	11	
ACT to PRE command period		tRAS	35	9 x tREFI	nS	11	
ACT to ACT or REF command period		tRC	48.75 ^{*13} (48.50) ^{*4,11}	-	nS	11	
	Normal	Read DBI					
CWL = 9	CL = 9	CL = 11 (Optional) ^{*4,11}	tCK(AVG)	1.5 (Optional) ^{*4,11,13}	1.6	nS	1, 2, 3, 10
			tCK(AVG)	1.25			
CWL = 9,11	CL = 11	CL = 13	tCK(AVG)	1.25	< 1.5	nS	1, 2, 3
	CL = 12	CL = 14	tCK(AVG)	1.25	< 1.5	nS	1, 2, 3
Supported CL Settings			(9), 11, 12		nCK	12, 13	
Supported CL Settings with read DBI			(11), 13, 14		nCK	12	
Supported CWL Settings			9, 11		nCK		

Note:

Field value contents in blue font or parentheses are optional AC parameter and Read non DBI, Read DBI CL setting.



Table 100 – DDR4-1866 Speed Bin and Operations

Speed Bin			DDR4-1866		Unit	Notes	
CL-nRCD-nRP			13-13-13				
Parameter	Symbol		Min.	Max.			
Internal read command to first data	tAA		13.92 ^{*13} (13.50) ^{*4,11}	18.00	nS	11	
Internal read command to first data with read DBI enabled	tAA_DBI		tAA(min) + 2nCK	tAA(max) + 2nCK	nS	11	
ACT to internal read or write delay time	tRCD		13.92 ^{*13} (13.50) ^{*4,11}	-	nS	11	
PRE command period	tRP		13.92 ^{*13} (13.50) ^{*4,11}	-	nS	11	
ACT to PRE command period	tRAS		34	9 x tREFI	nS	11	
ACT to ACT or REF command period	tRC		47.92 ^{*13} (47.50) ^{*4,11}	-	nS	11	
	Normal	Read DBI					
CWL = 9	CL = 9	CL = 11 (Optional) ^{*4,11}	tCK(AVG)	1.5 (Optional) ^{*4,11,13}	1.6	nS	1, 2, 3, 5, 10
			tCK(AVG)	1.25 (Optional) ^{*4,11}			
CWL = 9,11	CL = 11	CL = 13	tCK(AVG)	1.25	< 1.5	nS	1, 2, 3, 5
			tCK(AVG)	1.25			
CWL = 10,12	CL = 12	CL = 14	tCK(AVG)	1.071	< 1.25	nS	1, 2, 3
			tCK(AVG)	1.071			
Supported CL Settings			(9), (11), 12, 13, 14		nCK	12, 13	
Supported CL Settings with read DBI			(11), (13), 14, 15, 16		nCK	12	
Supported CWL Settings			9, 10, 11, 12		nCK		

Note:

Field value contents in blue font or parentheses are optional AC parameter and Read non DBI, Read DBI CL setting.



Table 101 – DDR4-2133 Speed Bin and Operations

Speed Bin			DDR4-2133		Unit	Notes	
CL-nRCD-nRP			15-15-15				
Parameter	Symbol		Min.	Max.			
Internal read command to first data		tAA	14.06 ^{*13} (13.50) ^{*4,11}	18.00	nS	11	
Internal read command to first data with read DBI enabled		tAA_DBI	tAA(min) + 3nCK	tAA(max) + 3nCK	nS	11	
ACT to internal read or write delay time		tRCD	14.06 ^{*13} (13.50) ^{*4,11}	-	nS	11	
PRE command period		tRP	14.06 ^{*13} (13.50) ^{*4,11}	-	nS	11	
ACT to PRE command period		tRAS	33	9 x tREFI	nS	11	
ACT to ACT or REF command period		tRC	47.06 ^{*13} (46.50) ^{*4,11}	-	nS	11	
	Normal	Read DBI					
CWL = 9	CL = 9	CL = 11 (Optional) ^{*4,11}	tCK(AVG)	1.5 (Optional) ^{*4,11,13}	1.6	nS	1, 2, 3, 6, 10
			tCK(AVG)	1.25	< 1.5	nS	1, 2, 3, 6
CWL = 9,11	CL = 11	CL = 13	tCK(AVG)	(Optional) ^{*4,11}		nS	1, 2, 3, 6
			tCK(AVG)	1.25	< 1.5	nS	1, 2, 3, 6
CWL = 10,12	CL = 13	CL = 15	tCK(AVG)	1.071 (Optional) ^{*4,11}	< 1.25	nS	1, 2, 3, 6
			tCK(AVG)	1.071	< 1.25	nS	1, 2, 3, 6
CWL = 11,14	CL = 15	CL = 18	tCK(AVG)	0.937	< 1.071	nS	1, 2, 3
			tCK(AVG)	0.937	< 1.071	nS	1, 2, 3
Supported CL Settings			(9), (11), 12, (13), 14, 15, 16		nCK	12, 13	
Supported CL Settings with read DBI			(11), (13), 14, (15), 16, 18, 19		nCK	12	
Supported CWL Settings			9, 10, 11, 12, 14		nCK		

Note:

Field value contents in blue font or parentheses are optional AC parameter and Read non DBI, Read DBI CL setting.



Table 102 – DDR4-2400 Speed Bin and Operations

Speed Bin			DDR4-2400		Unit	Notes	
CL-nRCD-nRP			17-17-17				
Parameter	Symbol		Min.	Max.			
Internal read command to first data	tAA		14.16 (13.75)* ^{4,11}	18.00	nS	11	
Internal read command to first data with read DBI enabled	tAA_DBI		tAA(min) + 3nCK	tAA(max) + 3nCK	nS	11	
ACT to internal read or write delay time	tRCD		14.16 (13.75)* ^{4,11}	-	nS	11	
PRE command period	tRP		14.16 (13.75)* ^{4,11}	-	nS	11	
ACT to PRE command period	tRAS		32	9 x tREFI	nS	11	
ACT to ACT or REF command period	tRC		46.16 (45.75)* ^{4,11}	-	nS	11	
	Normal	Read DBI					
CWL = 9	CL = 10	CL = 12	tCK(AVG)	1.5	1.6	nS	1, 2, 3, 7, 10
CWL = 9,11	CL = 11	CL = 13	tCK(AVG)	1.25	< 1.5	nS	1, 2, 3, 7
			(Optional)* ^{4,11}				
CWL = 10,12	CL = 12	CL = 14	tCK(AVG)	1.25	< 1.5	nS	1, 2, 3, 7
			(Optional)* ^{4,11}				
CWL = 10,12	CL = 13	CL = 15	tCK(AVG)	1.071	< 1.25	nS	1, 2, 3, 7
			(Optional)* ^{4,11}				
CWL = 11,14	CL = 14	CL = 16	tCK(AVG)	1.071	< 1.25	nS	1, 2, 3, 7
			(Optional)* ^{4,11}				
CWL = 11,14	CL = 15	CL = 18	tCK(AVG)	0.937	< 1.071	nS	1, 2, 3, 7
			(Optional)* ^{4,11}				
CWL = 12,16	CL = 16	CL = 19	tCK(AVG)	0.937	< 1.071	nS	1, 2, 3, 7
			(Optional)* ^{4,11}				
CWL = 12,16	CL = 17	CL = 20	tCK(AVG)	0.833	< 0.937	nS	1, 2, 3
	CL = 18	CL = 21	tCK(AVG)	0.833	< 0.937		
Supported CL Settings				10, (11), 12, (13), 14, (15), 16, 17, 18	nCK	12	
Supported CL Settings with read DBI				12, (13), 14, (15), 16, (18), 19, 20, 21	nCK	12	
Supported CWL Settings				9, 10, 11, 12, 14, 16	nCK		

Note:

Field value contents in blue font or parentheses are optional AC parameter and Read non DBI, Read DBI CL setting.



Table 103 – DDR4-2666 Speed Bin and Operations

Speed Bin			DDR4-2666		Unit	Notes	
CL-nRCD-nRP			19-19-19				
Parameter	Symbol		Min.	Max.			
Internal read command to first data	tAA		14.25 (13.75)*4,11	18.00	nS	11	
Internal read command to first data with read DBI enabled	tAA_DBI		tAA(min) + 3nCK	tAA(max) + 3nCK	nS	11	
ACT to internal read or write delay time	tRCD		14.25 (13.75)*4,11	-	nS	11	
PRE command period	tRP		14.25 (13.75)*4,11	-	nS	11	
ACT to PRE command period	tRAS		32	9 x tREFI	nS	11	
ACT to ACT or REF command period	tRC		46.25 (45.75)*4,11	-	nS	11	
	Normal	Read DBI					
CWL = 9	CL = 10	CL = 12	tCK(AVG)	1.5	1.6	nS	1, 2, 3, 8, 10
CWL = 9,11	CL = 11	CL = 13	tCK(AVG)	1.25	< 1.5	nS	1, 2, 3, 8
				(Optional)*4,11			
CWL = 10,12	CL = 12	CL = 14	tCK(AVG)	1.25	< 1.5	nS	1, 2, 3, 8
	CL = 13	CL = 15	tCK(AVG)	1.071	< 1.25	nS	1, 2, 3, 8
CWL = 11,14	CL = 14	CL = 16	tCK(AVG)	1.071	< 1.25	nS	1, 2, 3, 8
	CL = 15	CL = 18	tCK(AVG)	0.937	< 1.071	nS	1, 2, 3, 8
CWL = 12,16	CL = 16	CL = 19	tCK(AVG)	0.937	< 1.071	nS	1, 2, 3, 8
	CL = 17	CL = 20	tCK(AVG)	0.833	< 0.937	nS	1, 2, 3, 8
CWL = 14,18	CL = 18	CL = 21	tCK(AVG)	0.833	< 0.937	nS	1, 2, 3, 8
	CL = 19	CL = 22	tCK(AVG)	0.75	< 0.833	nS	1, 2, 3
	CL = 20	CL = 23	tCK(AVG)	0.75	< 0.833	nS	1, 2, 3
Supported CL Settings				10, (11), 12, (13), 14, (15), 16, (17), 18, 19, 20	nCK	12	
Supported CL Settings with read DBI				12, (13), 14, (15), 16, (18), 19, (20), 21, 22, 23	nCK	12	
Supported CWL Settings				9, 10, 11, 12, 14, 16, 18	nCK		

Note:

Field value contents in blue font or parentheses are optional AC parameter and Read non DBI, Read DBI CL setting.



Table 104 – DDR4-3200 Speed Bin and Operations

Speed Bin			DDR4-3200		Unit	Notes	
CL-nRCD-nRP			22-22-22				
Parameter	Symbol		Min.	Max.			
Internal read command to first data	tAA		13.75	18.00	nS	11	
Internal read command to first data with read DBI enabled	tAA_DBI		tAA(min) + 4nCK	tAA(max) + 4nCK	nS	11	
ACT to internal read or write delay time	tRCD		13.75	-	nS	11	
PRE command period	tRP		13.75	-	nS	11	
ACT to PRE command period	tRAS		32	9 x tREFI	nS	11	
ACT to ACT or REF command period	tRC		45.75	-	nS	11	
	Normal	Read DBI					
CWL = 9	CL = 10	CL = 12	tCK(AVG)	1.5	1.6	nS	1, 2, 3, 9, 10
CWL = 9,11	CL = 11	CL = 13	tCK(AVG)	1.25	< 1.5	nS	1, 2, 3, 9
	CL = 12	CL = 14	tCK(AVG)	1.25	< 1.5	nS	1, 2, 3, 9
CWL = 10,12	CL = 13	CL = 15	tCK(AVG)	1.071	< 1.25	nS	1, 2, 3, 9
	CL = 14	CL = 16	tCK(AVG)	1.071	< 1.25	nS	1, 2, 3, 9
CWL = 11,14	CL = 15	CL = 18	tCK(AVG)	0.937	< 1.071	nS	1, 2, 3, 9
	CL = 16	CL = 19	tCK(AVG)	0.937	< 1.071	nS	1, 2, 3, 9
CWL = 12,16	CL = 17	CL = 20	tCK(AVG)	0.833	< 0.937	nS	1, 2, 3, 9
	CL = 18	CL = 21	tCK(AVG)	0.833	< 0.937	nS	1, 2, 3, 9
CWL = 14,18	CL = 19	CL = 22	tCK(AVG)	0.75	< 0.833	nS	1, 2, 3, 9
	CL = 20	CL = 23	tCK(AVG)	0.75	< 0.833	nS	1, 2, 3, 9
CWL = 16,20	CL = 21	CL = 25	tCK(AVG)	0.682	< 0.75	nS	1, 2, 3, 9
	CL = 22	CL = 26	tCK(AVG)	0.682	< 0.75	nS	1, 2, 3, 9
	CL = 24	CL = 28	tCK(AVG)	0.682	< 0.75	nS	1, 2, 3, 9
CWL = 16,20	CL = 22	CL = 26	tCK(AVG)	0.625	< 0.682	nS	1, 2, 3
	CL = 24	CL = 28	tCK(AVG)	0.625	< 0.682	nS	1, 2, 3
Supported CL Settings			10, 11, 12, 13, 14, 15, 16, 17, 18, 19, 20, 21, 22, 24		nCK		
Supported CL Settings with read DBI			12, 13, 14, 15, 16, 18, 19, 20, 21, 22, 23, 25, 26, 28		nCK		
Supported CWL Settings			9, 10, 11, 12, 14, 16, 18, 20		nCK		



14.1 Speed Bin Table Note

Absolute Specification

- VDDQ = VDD = 1.2V ± 0.06V
- VPP = 2.5V +0.25/-0.125V
- The values defined with above-mentioned table are DLL ON case.
- DDR4-1600, 1866, 2133 and 2400 Speed Bin Tables are valid only when Gear-down Mode is disabled.

1. The CL setting and CWL setting result in tCK(avg).MIN and tCK(avg).MAX requirements. When making a selection of tCK(avg), both need to be fulfilled: Requirements from CL setting as well as requirements from CWL setting.
2. tCK(avg).MIN limits: Since CAS Latency is not purely analog - data and strobe output are synchronized by the DLL - all possible intermediate frequencies may not be guaranteed. CL in clock cycle is calculated from tAA following rounding algorithm defined in Section 17.5.
3. tCK(avg).MAX limits: Calculate $tCK(avg) = tAA.MAX / CL\ SELECTED$ and round the resulting tCK(avg) down to the next valid speed bin (i.e. 1.5nS or 1.25nS or 1.071nS or 0.937nS or 0.833nS). This result is tCK(avg).MAX corresponding to CL SELECTED.
4. "Optional" settings allow certain devices in the industry to support this setting. Any combination of the "optional" CL's is supported. The associated "optional" tAA, tRCD, tRP, and tRC values must be adjusted based upon the CL combination supported.
5. Any DDR4-1866 speed bin also supports functional operation at lower frequencies as shown in the table which are not subject to Production Tests but verified by Design/Characterization.
6. Any DDR4-2133 speed bin also supports functional operation at lower frequencies as shown in the table which are not subject to Production Tests but verified by Design/Characterization.
7. Any DDR4-2400 speed bin also supports functional operation at lower frequencies as shown in the table which are not subject to Production Tests but verified by Design/Characterization.
8. Any DDR4-2666 speed bin also supports functional operation at lower frequencies as shown in the table which are not subject to Production Tests but verified by Design/Characterization.
9. Any DDR4-3200 speed bin also supports functional operation at lower frequencies as shown in the table which are not subject to Production Tests but verified by Design/Characterization.
10. DDR4-1600 AC timing apply if DRAM operates at lower than 1600 MT/s data rate.
11. Parameters apply from tCK(avg)min to tCK(avg)max at all standard JEDEC clock period values as stated in the Speed Bin Tables.
12. CL number in parentheses, it means that these numbers are optional.
13. DDR4 SDRAM supports CL=9 as long as a system meets tAA(min), tRCD(min), tRP(min), and tRC(min).



15. IDD and IDDQ Specification Parameters and Test Conditions

15.1 IDD, IPP and IDDQ Measurement Conditions

In this chapter, IDD, IPP and IDDQ measurement conditions such as test load and patterns are defined. Figure 195 shows the setup and test load for IDD, IPP and IDDQ measurements.

- IDD currents (such as IDD0, IDD0A, IDD1, IDD1A, IDD2N, IDD2NA, IDD2NL, IDD2NT, IDD2P, IDD2Q, IDD3N, IDD3NA, IDD3P, IDD4R, IDD4RA, IDD4W, IDD4WA, IDD5B, IDD5F2, IDD5F4, IDD6N, IDD6E, IDD6R, IDD6A and IDD7) are measured as time-averaged currents with all VDD balls of the DDR4 SDRAM under test tied together. Any IPP or IDDQ current is not included in IDD currents.
- IPP currents have the same definition as IDD except that the current on the VPP supply is measured.
- IDDQ currents (such as IDDQ2NT and IDDQ4R) are measured as time-averaged currents with all VDDQ balls of the DDR4 SDRAM under test tied together. Any IDD current is not included in IDDQ currents. Attention: IDDQ values cannot be directly used to calculate IO power of the DDR4 SDRAM. They can be used to support correlation of simulated IO power to actual IO power as outlined in Figure 196. In DRAM module application, IDDQ cannot be measured separately since VDD and VDDQ are using one merged-power layer in Module PCB.

For IDD, IPP and IDDQ measurements, the following definitions apply:

- “0” and “LOW” is defined as $V_{IN} \leq V_{ILAC}(\max)$.
- “1” and “HIGH” is defined as $V_{IN} \geq V_{IHAC}(\min)$.
- “MID-LEVEL” is defined as inputs are $V_{REF} = V_{DD} / 2$.
- Timings used for IDD, IPP and IDDQ Measurement-Loop Patterns are provided in Table 105.
- Basic IDD, IPP and IDDQ Measurement Conditions are described in Table 106.
- Detailed IDD, IPP and IDDQ Measurement-Loop Patterns are described in Table 107 through Table 115.
- IDD Measurements are done after properly initializing the DDR4 SDRAM. This includes but is not limited to setting
 - RON = RZQ/7 (34 Ohm in MR1);
 - RTT_NOM = RZQ/6 (40 Ohm in MR1);
 - RTT_WR = RZQ/2 (120 Ohm in MR2);
 - RTT_PARK = Disable;
 - Qoff = 0_B (Output Buffer enabled) in MR1;
 - CRC disabled in MR2;
 - CA parity feature disabled in MR5;
 - Gear-down mode disabled in MR3
 - Read/Write DBI disabled in MR5;
 - DM disabled in MR5
- Attention: The IDD, IPP and IDDQ Measurement-Loop Patterns need to be executed at least one time before actual IDD or IDDQ measurement is started.
- Define D = {CS_n, ACT_n, RAS_n, CAS_n, WE_n} := {HIGH, LOW, LOW, LOW, LOW}; apply BG/BA changes when directed
- Define D# = {CS_n, ACT_n, RAS_n, CAS_n, WE_n} := {HIGH, HIGH, HIGH, HIGH, HIGH}; apply invert of BG/BA changes when directed above

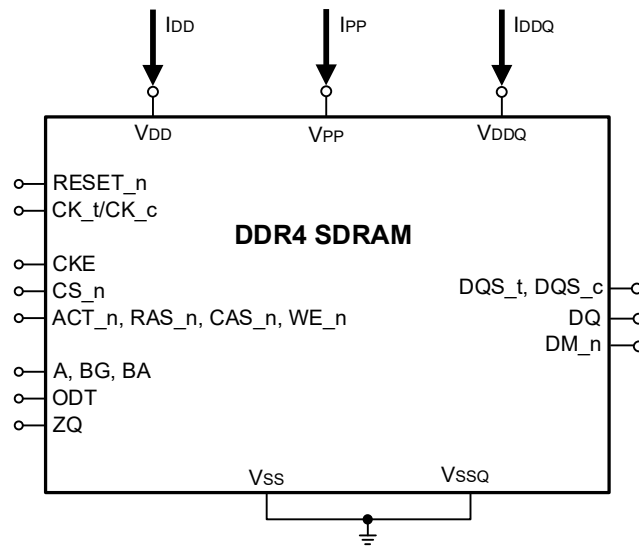

Note:

1. DIMM level Output test load condition may be different from above.

Figure 195 – Measurement Setup and Test Load for IDD, IPP and IDDQ Measurements

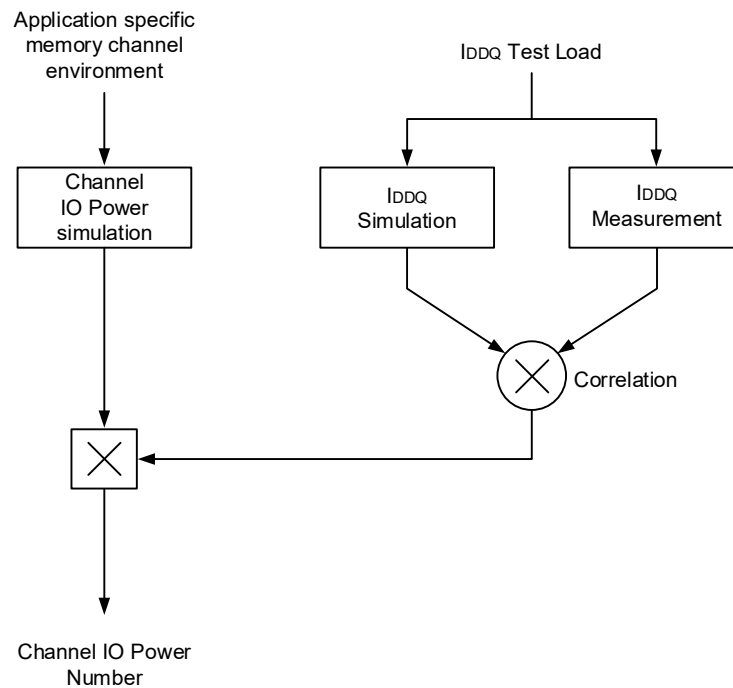

Figure 196 – Correlation from simulated Channel IO Power to actual Channel IO Power supported by IDDQ Measurement



Table 105 – Timings used for IDD, IPP and IDDQ Measurement-Loop Patterns

Symbol	DDR4-1600	DDR4-1866	DDR4-2133	DDR4-2400	DDR4-2666	DDR4-3200	Unit
	11-11-11	13-13-13	15-15-15	17-17-17	19-19-19	22-22-22	
tCK	1.25	1.071	0.938	0.833	0.75	0.625	nS
CL	11	13	15	17	19	22	nCK
CWL	11	12	14	16	18	20	nCK
nRCD	11	13	15	17	19	22	nCK
nRC	39	45	51	56	62	74	nCK
nRAS	28	32	36	39	43	52	nCK
nRP	11	13	15	17	19	22	nCK
nFAW	28	28	32	36	40	48	nCK
nRRDS	5	6	6	7	8	9	nCK
nRRDL	6	6	7	8	9	11	nCK
tCCD_S	4	4	4	4	4	4	nCK
tCCD_L	5	5	6	6	7	8	nCK
tWTR_S	2	3	3	3	4	4	nCK
tWTR_L	6	7	8	9	10	12	nCK
nRFC 4Gb	208	243	278	313	347	416	nCK



Table 106 – Basic IDD, IPP and IDDQ Measurement Conditions

Symbol	Description
IDD0	Operating One Bank Active-Precharge Current (AL=0) CKE: High; External clock: On; tCK, nRC, nRAS, CL: see Table 105; BL: 8*1; AL: 0; CS_n: High between ACT and PRE; Command, Address, Bank Group Address, Bank Address Inputs: partially toggling according to Table 107; Data IO: VDDQ, DM_n: stable at 1; Bank Activity: Cycling with one bank active at a time: 0,0,1,1,2,2,... (see Table 107); Output Buffer and RTT: Enabled in Mode Registers*2; ODT Signal: stable at 0; Pattern Details: see Table 107
IDD0A	Operating One Bank Active-Precharge Current (AL=CL-1) AL=CL-1, other conditions: see IDD0
IPP0	Operating One Bank Active-Precharge IPP Current Same condition with IDD0
IDD1	Operating One Bank Active-Read-Precharge Current (AL=0) CKE: High; External clock: On; tCK, nRC, nRAS, nRCD, CL: see Table 105; BL: 8*1; AL: 0; CS_n: High between ACT, RD and PRE; Command, Address, Bank Group Address, Bank Address Inputs, Data IO: partially toggling according to Table 108; DM_n: stable at 1; Bank Activity: Cycling with one bank active at a time: 0,0,1,1,2,2,... (see Table 108); Output Buffer and RTT: Enabled in Mode Registers*2; ODT Signal: stable at 0; Pattern Details: see Table 108
IDD1A	Operating One Bank Active-Read-Precharge Current (AL=CL-1) AL=CL-1, other conditions: see IDD1
IPP1	Operating One Bank Active-Read-Precharge IPP Current Same condition with IDD1
IDD2N	Precharge Standby Current (AL=0) CKE: High; External clock: On; tCK, CL: see Table 105; BL: 8*1; AL: 0; CS_n: stable at 1; Command, Address, Bank Group Address, Bank Address Inputs: partially toggling according to Table 109; Data IO: VDDQ; DM_n: stable at 1; Bank Activity: all banks closed; Output Buffer and RTT: Enabled in Mode Registers*2; ODT Signal: stable at 0; Pattern Details: see Table 109
IDD2NA	Precharge Standby Current (AL=CL-1) AL=CL-1, other conditions: see IDD2N
IPP2N	Precharge Standby IPP Current Same condition with IDD2N
IDD2NT	Precharge Standby ODT Current CKE: High; External clock: On; tCK, CL: see Table 105; BL: 8*1; AL: 0; CS_n: stable at 1; Command, Address, Bank Group Address, Bank Address Inputs: partially toggling according to Table 111; Data IO: VSSQ; DM_n: stable at 1; Bank Activity: all banks closed; Output Buffer and RTT: Enabled in Mode Registers*2; ODT Signal: toggling according to Table 110; Pattern Details: see Table 110
IDDQ2NT	Precharge Standby ODT IDDQ Current Same definition like for IDD2NT, however measuring IDDQ current instead of IDD current
IDD2NL	Precharge Standby Current with CAL enabled Same definition like for IDD2N, CAL enabled*3
IDD2NG	Precharge Standby Current with Gear-Down mode enabled Same definition like for IDD2N, Gear-Down mode enabled*3,5
IDD2ND	Precharge Standby Current with DLL disabled Same definition like for IDD2N, DLL disabled*3
IDD2N_par	Precharge Standby Current with CA parity enabled Same definition like for IDD2N, CA parity enabled*3
IDD2P	Precharge Power-Down Current CKE: Low; External clock: On; tCK, CL: see Table 105; BL: 8*1; AL: 0; CS_n: stable at 1; Command, Address, Bank Group Address, Bank Address Inputs: stable at 0; Data IO: VDDQ; DM_n: stable at 1; Bank Activity: all banks closed; Output Buffer and RTT: Enabled in Mode Registers*2; ODT Signal: stable at 0



Symbol	Description
IPP2P	Precharge Power-Down IPP Current Same condition with IDD2P
IDD2Q	Precharge Quiet Standby Current CKE: High; External clock: On; tCK, CL: see Table 105; BL: 8*1; AL: 0; CS_n: stable at 1; Command, Address, Bank Group Address, Bank Address Inputs: stable at 0; Data IO: VDDQ; DM_n: stable at 1; Bank Activity: all banks closed; Output Buffer and RTT: Enabled in Mode Registers*2; ODT Signal: stable at 0
IDD3N	Active Standby Current CKE: High; External clock: On; tCK, CL: see Table 105; BL: 8*1; AL: 0; CS_n: stable at 1; Command, Address, Bank Group Address, Bank Address Inputs: partially toggling according to Table 109; Data IO: VDDQ; DM_n: stable at 1; Bank Activity: all banks open; Output Buffer and RTT: Enabled in Mode Registers*2; ODT Signal: stable at 0; Pattern Details: see Table 109
IDD3NA	Active Standby Current (AL=CL-1) AL=CL-1, other conditions: see IDD3N
IPP3N	Active Standby IPP Current Same condition with IDD3N
IDD3P	Active Power-Down Current CKE: Low; External clock: On; tCK, CL: see Table 105; BL: 8*1; AL: 0; CS_n: stable at 1; Command, Address, Bank Group Address, Bank Address Inputs: stable at 0; Data IO: VDDQ; DM_n: stable at 1; Bank Activity: all banks open; Output Buffer and RTT: Enabled in Mode Registers*2; ODT Signal: stable at 0
IPP3P	Active Power-Down IPP Current Same condition with IDD3P
IDD4R	Operating Burst Read Current CKE: High; External clock: On; tCK, CL: see Table 105; BL: 8*1; AL: 0; CS_n: High between RD; Command, Address, Bank Group Address, Bank Address Inputs: partially toggling according to Table 111; Data IO: seamless read data burst with different data between one burst and the next one according to Table 111; DM_n: stable at 1; Bank Activity: all banks open, RD commands cycling through banks: 0,0,1,1,2,2,... (see Table 111); Output Buffer and RTT: Enabled in Mode Registers*2; ODT Signal: stable at 0; Pattern Details: see Table 111
IDD4RA	Operating Burst Read Current (AL=CL-1) AL=CL-1, other condition: see IDD4R
IDD4RB	Operating Burst Read Current with Read DBI Read DBI enabled*3, other conditions: see IDD4R
IPP4R	Operating Burst Read IPP Current Same condition with IDD4R
IDDQ4R	Operating Burst Read IDDQ Current Same definition like for IDD4R, however measuring IDDQ current instead of IDD current
IDDQ4RB	Operating Burst Read IDDQ Current with Read DBI Same definition like for IDD4RB, however measuring IDDQ current instead of IDD current
IDD4W	Operating Burst Write Current CKE: High; External clock: On; tCK, CL: see Table 105; BL: 8*1; AL: 0; CS_n: High between WR; Command, Address, Bank Group Address, Bank Address Inputs: partially toggling according to Table 112; Data IO: seamless write data burst with different data between one burst and the next one according to Table 112; DM_n: stable at 1; Bank Activity: all banks open, WR commands cycling through banks: 0,0,1,1,2,2,... (see Table 112); Output Buffer and RTT: Enabled in Mode Registers*2; ODT Signal: stable at HIGH; Pattern Details: see Table 112
IDD4WA	Operating Burst Write Current (AL=CL-1) AL=CL-1, other condition: see IDD4W
IDD4WB	Operating Burst Read Current with Write DBI Read DBI enabled*3, other conditions: see IDD4W



Symbol	Description
IDD4WC	Operating Burst Write Current with CRC Write CRC enable* ³ , Other condition: see IDD4W
IDDW4W_par	Operating Burst Write Current with CA Parity CA Parity enabled* ³ , Other condition: see IDD4W
IPP4W	Operating Burst Write IPP Current Same condition with IDD4W
IDD5B	Burst Refresh Current (1X REF) CKE: High; External clock: On; tCK, CL, nRFC: see Table 105; BL: 8* ¹ ; AL: 0; CS_n: High between REF; Command, Address, Bank Group Address, Bank Address Inputs: partially toggling according to Table 114; Data IO: VDDQ; DM_n: stable at 1; Bank Activity: REF command every nRFC (see Table 114); Output Buffer and RTT: Enabled in Mode Registers* ² ; ODT Signal: stable at 0; Pattern Details: see Table 114
IPP5B	Burst Refresh Write IPP Current (1X REF) Same condition with IDD5B
IDD5F2	Burst Refresh Current (2X REF) tREF=tREFC_x2, other conditions: see IDD5B
IPP5F2	Burst Refresh Write IPP Current (2X REF) Same condition with IDD5F2
IDD5F4	Burst Refresh Current (4X REF) tREF=tREFC_x4, other conditions: see IDD5B
IPP5F4	Burst Refresh Write IPP Current (4X REF) Same condition with IDD5F4
IDD6N	Self Refresh Current: Normal Temperature Range TCASE: -40~85°C; Low Power Auto Self-Refresh (LP ASR): Normal* ⁴ ; CKE: Low; External clock: Off; CK_t and CK_c#: LOW; CL: see Table 105; BL: 8* ¹ ; AL: 0; CS_n#, Command, Address, Bank Group Address, Bank Address, Data IO: High; DM_n: stable at 1; Bank Activity: Self-Refresh operation; Output Buffer and RTT: Enabled in Mode Registers* ² ; ODT Signal: MID-LEVEL
IPP6N	Self Refresh IPP Current: Normal Temperature Range Same condition with IDD6N
IDD6E	Self-Refresh Current: Extended Temperature Range TCASE: -40~95°C; Low Power Auto Self-Refresh (LP ASR): Extended* ⁴ ; CKE: Low; External clock: Off; CK_t and CK_c#: LOW; CL: see Table 105; BL: 8* ¹ ; AL: 0; CS_n, Command, Address, Bank Group Address, Bank Address, Data IO: High; DM_n: stable at 1; Bank Activity: Extended Temperature Self-Refresh operation; Output Buffer and RTT: Enabled in Mode Registers* ² ; ODT Signal: MID-LEVEL
IPP6E	Self Refresh IPP Current: Extended Temperature Range Same condition with IDD6E
IDD6R	Self-Refresh Current: Reduced Temperature Range TCASE: -40~45°C; Low Power Auto Self-Refresh (LP ASR): Reduced* ⁴ ; CKE: Low; External clock: Off; CK_t and CK_c#: LOW; CL: see Table 105; BL: 8* ¹ ; AL: 0; CS_n#, Command, Address, Bank Group Address, Bank Address, Data IO: High; DM_n: stable at 1; Bank Activity: Extended Temperature Self-Refresh operation; Output Buffer and RTT: Enabled in Mode Registers* ² ; ODT Signal: MID-LEVEL
IPP6R	Self Refresh IPP Current: Reduced Temperature Range Same condition with IDD6R
IDD6A	Auto Self-Refresh Current TCASE: -40~95°C; Low Power Auto Self-Refresh (LP ASR): Auto* ⁴ ; CKE: Low; External clock: Off; CK_t and CK_c#: LOW; CL: see Table 105; BL: 8* ¹ ; AL: 0; CS_n#, Command, Address, Bank Group Address, Bank Address, Data IO: High; DM_n: stable at 1; Bank Activity: Auto Self-Refresh operation; Output Buffer and RTT: Enabled in Mode Registers* ² ; ODT Signal: MID-LEVEL
IPP6A	Auto Self Refresh IPP Current Same condition with IDD6A



Symbol	Description
IDD7	Operating Bank Interleave Read Current CKE: High; External clock: On; tCK, nRC, nRAS, nRCD, nRRD, nFAW, CL: see Table 105; BL: 8*1; AL: CL-1; CS_n: High between ACT and RDA; Command, Address, Bank Group Address, Bank Address Inputs: partially toggling according to Table 115; Data IO: read data bursts with different data between one burst and the next one according to Table 115; DM_n: stable at 1; Bank Activity: two times interleaved cycling through banks (0, 1, ...7) with different addressing, see Table 115; Output Buffer and RTT: Enabled in Mode Registers*2; ODT Signal: stable at 0; Pattern Details: see Table 115
IPP7	Operating Bank Interleave Read IPP Current Same condition with IDD7

Notes:

- Burst Length: BL8 fixed by MRS: set MR0 A[1:0] = 00.
- Output Buffer Enable
 - set MR1 A[12] = 0: Qoff = Output buffer enabled
 - set MR1 A[2:1] = 00: Output Driver Impedance Control = RZQ/7
 - RTT_Nom enable
 - set MR1 A[10:8] = 011: RTT_NOM = RZQ/6
 - RTT_WR enable
 - set MR2 A[10:9] = 01: RTT_WR = RZQ/2
 - RTT_PARK disable
 - set MR5 A[8:6] = 000
- CAL Enabled:
 - Gear-Down mode Disabled:
 - Set MR4 A[8:6] = 001 (CAL = 3 tCK cycles): 1600MT/s
 - 010 (CAL = 4 tCK cycles): 1866MT/s, 2133MT/s
 - 011 (CAL = 5 tCK cycles): 2400MT/s, 2666MT/s
 - 100 (CAL = 6 tCK cycles): 3200MT/s
 - Gear-Down mode Enabled:
 - Set MR4 A[8:6] = 100 (CAL = 6 tCK cycles): 2666MT/s, 3200MT/s
 - Gear-Down mode Enabled: set MR3 A[3] = 1: 1/4 Rate
 - DLL Disabled: set MR1 A[0] = 0
 - CA parity Enabled: set MR5 A[2:0] = 001: 1600MT/s, 1866MT/s, 2133MT/s
 - 010: 2400MT/s, 2666MT/s
 - 011: 3200MT/s
 - Read DBI Enabled: set MR5 A[12] = 1
 - Write DBI Enabled: set MR5 A[11] = 1
- Low Power Auto Self Refresh (LP ASR): set MR2 A[7:6] = 00: Normal
 - 01: Reduced Temperature range
 - 10: Extended Temperature range
 - 11: Auto Self Refresh
- IDD2NG should be measured after sync pulse (NOP) input.



Table 107 – IDD0, IDD0A and IPP0 Measurement-Loop Pattern*1

CK_t, CK_c	CKE	Sub-Loop	Cycle Number	Command	CS_n	ACT_n	RAS_n, A16	CAS_n, A15	WE_n, A14	ODT	BG0	BA[1:0]	A12, BC_n	A[13,11]	A[10], AP	A[9:7]	A[6:3]	A[2:0]	Data*2		
toggling	Static High	0	0	ACT	0	0	0	0	0	0	0	0	0	0	0	0	0	0	-		
			1, 2	D, D	1	0	0	0	0	0	0	0	0	0	0	0	0	0	0	0	-
			3, 4	D_#, D_#	1	1	1	1	1	1	0	1	3	0	0	0	7	F	0	0	-
			...	Repeat pattern 1...4 until nRAS - 1, truncate if necessary																	
			nRAS	PRE	0	1	0	1	0	0	0	0	0	0	0	0	0	0	0	0	-
			...	Repeat pattern 1...4 until nRC - 1, truncate if necessary																	
		1	1*nRC	Repeat Sub-Loop 0, use BG0 = 1, BA[1:0] = 1 instead																	
		2	2*nRC	Repeat Sub-Loop 0, use BG0 = 0, BA[1:0] = 2 instead																	
		3	3*nRC	Repeat Sub-Loop 0, use BG0 = 1, BA[1:0] = 3 instead																	
		4	4*nRC	Repeat Sub-Loop 0, use BG0 = 0, BA[1:0] = 1 instead																	
		5	5*nRC	Repeat Sub-Loop 0, use BG0 = 1, BA[1:0] = 2 instead																	
		6	6*nRC	Repeat Sub-Loop 0, use BG0 = 0, BA[1:0] = 3 instead																	
		7	7*nRC	Repeat Sub-Loop 0, use BG0 = 1, BA[1:0] = 0 instead																	

Notes:

1. DQS_t, DQS_c are VDDQ.
2. DQ signals are VDDQ



Table 108 – IDD1, IDD1A and IPP1 Measurement-Loop Pattern*1

CK_t, CK_c	CKE	Sub-Loop	Cycle Number	Command	CS_n	ACT_n	RAS_n, A16	CAS_n, A15	WE_n, A14	ODT	BG0	BA[1:0]	A12, BC_n	A[13,14]	A[10], AP	A[9:7]	A[6:3]	A[2:0]	Data*2			
toggling	Static High	0	0	ACT	0	0	0	0	0	0	0	0	0	0	0	0	0	0	0	-		
			1, 2	D, D	1	0	0	0	0	0	0	0	0	0	0	0	0	0	0	0	-	
			3, 4	D#, D#	1	1	1	1	1	1	0	1	3	0	0	0	7	F	0	0	-	
			...	Repeat pattern 1...4 until nRCD - AL - 1, truncate if necessary																		
			nRCD - AL	RD	0	1	1	0	1	0	0	0	0	0	0	0	0	0	0	0	0	D0=00, D1=FF D2=FF, D3=00 D4=FF, D5=00 D6=00, D7=FF
			...	Repeat pattern 1...4 until nRAS - 1, truncate if necessary																		
			nRAS	PRE	0	1	0	1	0	0	0	0	0	0	0	0	0	0	0	0	0	-
			...	Repeat pattern 1...4 until nRC - 1, truncate if necessary																		
		1*nRC + 0	ACT	0	0	0	1	1	0	1	1	0	1	1	0	0	0	0	0	0	-	
		1*nRC + 1,2	D, D	1	0	0	0	0	0	0	0	0	0	0	0	0	0	0	0	0	-	
		1*nRC + 3,4	D#, D#	1	1	1	1	1	1	1	0	1	3	0	0	0	7	F	0	0	-	
		...	Repeat pattern 1...4 until 1*nRC + nRAS - 1, truncate if necessary																			
		1*nRC + nRCD - AL	RD	0	1	1	0	1	0	1	0	1	1	0	0	0	0	0	0	0	D0=FF, D1=00 D2=00, D3=FF D4=00, D5=FF D6=FF, D7=00	
		...	Repeat pattern 1...4 until nRAS - 1, truncate if necessary																			
		1*nRC + nRAS	PRE	0	1	0	1	0	0	0	0	1	1	0	0	0	0	0	0	0	-	
		...	Repeat nRC + 1...4 until 2*nRC - 1, truncate if necessary																			
		2	2*nRC	Repeat Sub-Loop 0, use BG0 = 0, BA[1:0] = 2 instead																		
		3	3*nRC	Repeat Sub-Loop 1, use BG0 = 1, BA[1:0] = 3 instead																		
		4	4*nRC	Repeat Sub-Loop 0, use BG0 = 0, BA[1:0] = 1 instead																		
		5	5*nRC	Repeat Sub-Loop 1, use BG0 = 1, BA[1:0] = 2 instead																		
		6	6*nRC	Repeat Sub-Loop 0, use BG0 = 0, BA[1:0] = 3 instead																		
		8	7*nRC	Repeat Sub-Loop 1, use BG0 = 1, BA[1:0] = 0 instead																		

Notes:

1. DQS_t, DQS_c are used according to RD Commands, otherwise VDDQ
2. Burst Sequence driven on each DQ signal by Read Command. Outside burst operation, DQ signals are VDDQ.



Table 109 – IDD2N, IDD2NA, IDD2NL, IDD2NG, IDD2ND, IDD2N_par, IPP2, IDD3N, IDD3NA and IDD3P
Measurement-Loop Pattern*1

CK_t, CK_c	CKE	Sub-Loop	Cycle Number	Command	CS_n	ACT_n	RAS_n, A16	CAS_n, A15	WE_n, A14	ODT	BG0	BA[1:0]	A12, BC_n	A[13,11]	A[10], AP	A[9:7]	A[6:3]	A[2:0]	Data*2			
toggling	Static High	0	0	D, D	1	0	0	0	0	0	0	0	0	0	0	0	0	0	0	0		
			1	D, D	1	0	0	0	0	0	0	0	0	0	0	0	0	0	0	0	0	0
			2	D#, D#	1	1	1	1	1	1	0	1	3	0	0	0	0	7	F	0	0	0
			3	D#, D#	1	1	1	1	1	1	0	1	3	0	0	0	0	7	F	0	0	0
		1	4-7	Repeat Sub-Loop 0, but ODT = 1 and BG0 = 1, BA[1:0] = 1 instead																		
		2	8-11	Repeat Sub-Loop 0, but ODT = 0 and BG0 = 0, BA[1:0] = 2 instead																		
		3	12-15	Repeat Sub-Loop 0, but ODT = 1 and BG0 = 1, BA[1:0] = 3 instead																		
		4	16-19	Repeat Sub-Loop 0, but ODT = 0 and BG0 = 0, BA[1:0] = 1 instead																		
		5	20-23	Repeat Sub-Loop 0, but ODT = 1 and BG0 = 1, BA[1:0] = 2 instead																		
		6	24-27	Repeat Sub-Loop 0, but ODT = 0 and BG0 = 0, BA[1:0] = 3 instead																		
7	28-31	Repeat Sub-Loop 0, but ODT = 1 and BG0 = 1, BA[1:0] = 0 instead																				

Notes:

1. DQS_t, DQS_c are VDDQ.
2. DQ signals are VDDQ.



Table 110 – IDD2NT and IDDQ2NT Measurement-Loop Pattern*1

CK_t, CK_c	CKE	Sub-Loop	Cycle Number	Command	CS_n	ACT_n	RAS_n, A16	CAS_n, A15	WE_n, A14	ODT	BG0	BA[1:0]	A12, BC_n	A[13,11]	A[10], AP	A[9:7]	A[6:3]	A[2:0]	Data*2		
toggling	Static High	0	0	D, D	1	0	0	0	0	0	0	0	0	0	0	0	0	0	0	-	
			1	D, D	1	0	0	0	0	0	0	0	0	0	0	0	0	0	0	0	-
			2	D#, D#	1	1	1	1	1	1	0	1	3	0	0	0	0	7	F	0	-
			3	D#, D#	1	1	1	1	1	1	0	1	3	0	0	0	0	7	F	0	-
		1	4-7	Repeat Sub-Loop 0, but ODT = 1 and BG0 = 1, BA[1:0] = 1 instead																	
		2	8-11	Repeat Sub-Loop 0, but ODT = 0 and BG0 = 0, BA[1:0] = 2 instead																	
		3	12-15	Repeat Sub-Loop 0, but ODT = 1 and BG0 = 1, BA[1:0] = 3 instead																	
		4	16-19	Repeat Sub-Loop 0, but ODT = 0 and BG0 = 0, BA[1:0] = 1 instead																	
		5	20-23	Repeat Sub-Loop 0, but ODT = 1 and BG0 = 1, BA[1:0] = 2 instead																	
		6	24-27	Repeat Sub-Loop 0, but ODT = 0 and BG0 = 0, BA[1:0] = 3 instead																	
7	28-31	Repeat Sub-Loop 0, but ODT = 1 and BG0 = 1, BA[1:0] = 0 instead																			

Notes:

1. DQS_t, DQS_c are VDDQ.
2. DQ signals are VDDQ.



Table 111 – IDD4R, IDDR4RA, IDD4RB and IDDQ4R Measurement-Loop Pattern*1

CK_t, CK_c	CKE	Sub-Loop	Cycle Number	Command	CS_n	ACT_n	RAS_n, A16	CAS_n, A15	WE_n, A14	ODT	BG0	BA[1:0]	A12, BC_n	A[13,11]	A[10], AP	A[9:7]	A[6:3]	A[2:0]	Data*2		
toggling	Static High	0	0	RD	0	1	1	0	1	0	0	0	0	0	0	0	0	0	D0=00, D1=FF D2=FF, D3=00 D4=FF, D5=00 D6=00, D7=FF		
			1	D	1	0	0	0	0	0	0	0	0	0	0	0	0	0	-		
			2,3	D#, D#	1	1	1	1	1	1	0	1	3	0	0	0	7	F	0	-	
		1	4	RD	0	1	1	0	1	0	0	1	1	0	0	0	7	F	0	D0=FF, D1=00 D2=00, D3=FF D4=00, D5=FF D6=FF, D7=00	
			5	D	1	0	0	0	0	0	0	0	0	0	0	0	0	0	0	0	-
			6,7	D#, D#	1	1	1	1	1	1	0	1	3	0	0	0	7	F	0	-	
		2	8-11	Repeat Sub-Loop 0, use BG0 = 0, BA[1:0] = 2 instead																	
		3	12-15	Repeat Sub-Loop 1, use BG0 = 1, BA[1:0] = 3 instead																	
		4	16-19	Repeat Sub-Loop 0, use BG0 = 0, BA[1:0] = 1 instead																	
		5	20-23	Repeat Sub-Loop 1, use BG0 = 1, BA[1:0] = 2 instead																	
		6	24-27	Repeat Sub-Loop 0, use BG0 = 0, BA[1:0] = 3 instead																	
		7	28-31	Repeat Sub-Loop 1, use BG0 = 1, BA[1:0] = 0 instead																	

Notes:

1. DQS_t, DQS_c are used according to RD Commands, otherwise VDDQ.
2. Burst Sequence driven on each DQ signal by Read Command.



Table 112 – IDD4W, IDD4WA, IDD4WB and IDD4W_par Measurement-Loop Pattern*1

CK_t, CK_c	CKE	Sub-Loop	Cycle Number	Command	CS_n	ACT_n	RAS_n, A16	CAS_n, A15	WE_n, A14	ODT	BG0	BA[1:0]	A12, BC_n	A[13,11]	A[10], AP	A[9:7]	A[6:3]	A[2:0]	Data*2		
toggling	Static High	0	0	WR	0	1	1	0	0	1	0	0	0	0	0	0	0	0	D0=00, D1=FF D2=FF, D3=00 D4=FF, D5=00 D6=00, D7=FF		
			1	D	1	0	0	0	0	0	1	0	0	0	0	0	0	0	0	-	
			2,3	D#, D#	1	1	1	1	1	1	1	1	3	0	0	0	7	F	0	-	
		1	4	WR	0	1	1	0	0	0	1	1	1	0	0	0	7	F	0	D0=FF, D1=00 D2=00, D3=FF D4=00, D5=FF D6=FF, D7=00	
			5	D	1	0	0	0	0	0	1	0	0	0	0	0	0	0	0	0	-
			6,7	D#, D#	1	1	1	1	1	1	1	1	3	0	0	0	7	F	0	-	
		2	8-11	Repeat Sub-Loop 0, use BG0 = 0, BA[1:0] = 2 instead																	
		3	12-15	Repeat Sub-Loop 1, use BG0 = 1, BA[1:0] = 3 instead																	
		4	16-19	Repeat Sub-Loop 0, use BG0 = 0, BA[1:0] = 1 instead																	
		5	20-23	Repeat Sub-Loop 1, use BG0 = 1, BA[1:0] = 2 instead																	
		6	24-27	Repeat Sub-Loop 0, use BG0 = 0, BA[1:0] = 3 instead																	
		7	28-31	Repeat Sub-Loop 1, use BG0 = 1, BA[1:0] = 0 instead																	

Notes:

1. DQS_t, DQS_c are used according to WR Commands, otherwise VDDQ.
2. Burst Sequence driven on each DQ signal by Write Command.



Table 113 – IDD4WC Measurement-Loop Pattern*1

CK_t, CK_c	CKE	Sub-Loop	Cycle Number	Command	CS_n	ACT_n	RAS_n, A16	CAS_n, A15	WE_n, A14	ODT	BG0	BA[1:0]	A12, BC_n	A[13,11]	A[10], AP	A[9:7]	A[6:3]	A[2:0]	Data*2		
toggling	Static High	0	0	WR	0	1	1	0	0	1	0	0	0	0	0	0	0	0	0	D0=00, D1=FF D2=FF, D3=00 D4=FF, D5=00 D6=00, D7=FF D8=CRC	
			1,2	D, D	1	0	0	0	0	0	1	0	0	0	0	0	0	0	0	0	-
			3,4	D#, D#	1	1	1	1	1	1	1	1	3	0	0	0	7	F	0	0	-
			5	WR	0	1	1	0	0	0	1	1	1	0	0	0	7	F	0	0	D0=FF, D1=00 D2=00, D3=FF D4=00, D5=FF D6=FF, D7=00 D8=CRC
			6,7	D, D	1	0	0	0	0	0	1	0	0	0	0	0	0	0	0	0	-
			8,9	D#, D#	1	1	1	1	1	1	1	1	3	0	0	0	7	F	0	0	-
		2	10-14	Repeat Sub-Loop 0, use BG0 = 0, BA[1:0] = 2 instead																	
		3	15-19	Repeat Sub-Loop 1, use BG0 = 1, BA[1:0] = 3 instead																	
		4	20-24	Repeat Sub-Loop 0, use BG0 = 0, BA[1:0] = 1 instead																	
		5	25-29	Repeat Sub-Loop 1, use BG0 = 1, BA[1:0] = 2 instead																	
		6	30-34	Repeat Sub-Loop 0, use BG0 = 0, BA[1:0] = 3 instead																	
		7	35-39	Repeat Sub-Loop 1, use BG0 = 1, BA[1:0] = 0 instead																	

Notes:

1. DQS_t, DQS_c are VDDQ.
2. Burst Sequence driven on each DQ signal by Write Command.



Table 114 – IDD5B Measurement-Loop Pattern*1

CK_t, CK_c	CKE	Sub-Loop	Cycle Number	Command	CS_n	ACT_n	RAS_n, A16	CAS_n, A15	WE_n, A14	ODT	BG0	BA[1:0]	A12, BC_n	A[13,11]	A[10], AP	A[9:7]	A[6:3]	A[2:0]	Data*2			
toggling	Static High	0	0	REF	1	0	0	0	0	0	0	0	0	0	0	0	0	0	0	-		
		1	1	D	1	0	0	0	0	0	0	0	0	0	0	0	0	0	0	0	-	
			2	D	1	0	0	0	0	0	0	0	0	0	0	0	0	0	0	0	-	
			3	D#, D#	1	1	1	1	1	1	0	1	3	0	0	0	7	F	0	0	-	
			4	D#, D#	1	1	1	1	1	1	0	1	3	0	0	0	7	F	0	0	-	
			4-7	Repeat pattern 1 ...4, use BG0 = 1, BA[1:0] = 1 instead																		
			8-11	Repeat pattern 1 ...4, use BG0 = 0, BA[1:0] = 2 instead																		
			12-15	Repeat pattern 1 ...4, use BG0 = 1, BA[1:0] = 3 instead																		
			16-19	Repeat pattern 1 ...4, use BG0 = 0, BA[1:0] = 1 instead																		
			20-23	Repeat pattern 1 ...4, use BG0 = 1, BA[1:0] = 2 instead																		
			24-27	Repeat pattern 1 ...4, use BG0 = 0, BA[1:0] = 3 instead																		
		28-31	Repeat pattern 1 ...4, use BG0 = 1, BA[1:0] = 0 instead																			
		2	32 ...nRFC -1	Repeat Sub-Loop 1, Truncate, if necessary																		

Notes:

1. DQS_t, DQS_c are VDDQ.
2. DQ signals are VDDQ.



Table 115 – IDD7 Measurement-Loop Pattern*1

CK_t, CK_c	CKE	Sub-Loop	Cycle Number	Command	CS_n	ACT_n	RAS_n, A16	CAS_n, A15	WE_n, A14	ODT	BG0	BA[1:0]	A12, BC_n	A[13,11]	A[10], AP	A[9:7]	A[6:3]	A[2:0]	Data*2			
toggling	Static High	0	0	ACT	0	0	0	0	0	0	0	0	0	0	0	0	0	0	0	-		
			1	RDA	0	1	1	0	1	0	0	0	0	0	0	1	0	0	0	0	D0=00, D1=FF D2=FF, D3=00 D4=FF, D5=00 D6=00, D7=FF	
			2	D	1	0	0	0	0	0	0	0	0	0	0	0	0	0	0	0	-	
			3	D#	1	1	1	1	1	1	0	1	3	0	0	0	7	F	0	0	-	
			...	Repeat pattern 2...3 until nRCD - 1, if nRRD > 4, truncate if necessary																		
		1	nRRD	ACT	0	0	0	0	0	0	0	0	1	1	0	0	0	0	0	0	0	-
			nRRD + 1	RDA	0	1	1	0	1	0	1	0	1	1	0	0	1	0	0	0	0	D0=FF, D1=00 D2=00, D3=FF D4=00, D5=FF D6=FF, D7=00
			...	Repeat pattern 2...3 until 2*nRRD - 1, if nRRD > 4. Truncate if necessary																		
		2	2*nRRD	Repeat Sub-Loop 0, use BG0 = 0, BA[1:0] = 2 instead																		
		3	3*nRRD	Repeat Sub-Loop 1, use BG0 = 1, BA[1:0] = 3 instead																		
4	4*nRRD	Repeat pattern 2...3 until nFAW - 1, if nFAW > 4*nRRD. Truncate if necessary																				
5	nFAW	Repeat Sub-Loop 0, use BG0 = 0, BA[1:0] = 1 instead																				
6	nFAW + nRRD	Repeat Sub-Loop 1, use BG0 = 1, BA[1:0] = 2 instead																				
7	nFAW + 2*nRRD	Repeat Sub-Loop 0, use BG0 = 0, BA[1:0] = 3 instead																				
8	nFAW + 3*nRRD	Repeat Sub-Loop 1, use BG0 = 1, BA[1:0] = 0 instead																				
9	nFAW + 4*nRRD	Repeat Sub-Loop 4																				
10	4*nFAW	Repeat pattern 2...3 until nRC - 1, if nRC > 4*nEAW. Truncate if necessary																				

Notes:

1. DQS_t, DQS_c are VDDQ.
2. Burst Sequence driven on each DQ signal by Read Command. Outside burst operation, DQ signals are VDDQ.



15.2 IDD, IDDQ & IPP Specifications

Table 116 – IDD and IDDQ Current Maximum Limits

Symbol	Description	DDR4-2400	DDR4-2666	DDR4-3200	Unit
IDD0	Operating One Bank Active-Precharge Current (AL=0)	40	43	45	mA
IDD0A	Operating One Bank Active-Precharge Current (AL=CL-1)	40	42	45	mA
IDD1	Operating One Bank Active-Read-Precharge Current (AL=0)	75	81	88	mA
IDD1A	Operating One Bank Active-Read-Precharge Current (AL=CL-1)	77	83	92	mA
IDD2N	Precharge Standby Current (AL=0)	23	24	26	mA
IDD2NA	Precharge Standby Current (AL=CL-1)	22	24	26	mA
IDD2NT	Precharge Standby ODT Current	26	28	30	mA
IDDQ2NT	Precharge Standby ODT IDDQ Current	6	6	6	mA
IDD2NL	Precharge Standby Current with CAL enabled	20	22	26	mA
IDD2NG	Precharge Standby Current with Gear-Down mode enabled	NA*1	25	27	mA
IDD2ND	Precharge Standby Current with DLL disabled	20	21	23	mA
IDD2N_par	Precharge Standby Current with CA parity enabled	20	21	23	mA
IDD2P	Precharge Power-Down Current	17	17	18	mA
IDD2Q	Precharge Quiet Standby Current	21	22	24	mA
IDD3N	Active Standby Current	34	35	37	mA
IDD3NA	Active Standby Current (AL=CL-1)	33	35	37	mA
IDD3P	Active Power-Down Current	20	21	22	mA
IDD4R	Operating Burst Read Current	152	168	195	mA
IDD4RA	Operating Burst Read Current (AL=CL-1)	155	172	200	mA
IDD4RB	Operating Burst Read Current with Read DBI	156	172	200	mA
IDDQ4R	Operating Burst Read IDDQ Current	33	38	44	mA
IDDQ4RB	Operating Burst Read IDDQ Current with Read DBI	31	35	40	mA
IDD4W	Operating Burst Write Current	142	157	183	mA
IDD4WA	Operating Burst Write Current (AL=CL-1)	145	160	187	mA
IDD4WB	Operating Burst Read Current with Write DBI	143	157	184	mA
IDD4WC	Operating Burst Write Current with CRC	126	139	162	mA
IDD4W_par	Operating Burst Write Current with CA Parity	151	166	191	mA
IDD5B	Burst Refresh Current (1X REF)	139	142	144	mA
IDD5F2	Burst Refresh Current (2X REF)	123	125	130	mA
IDD5F4	Burst Refresh Current (4X REF)	105	106	107	mA
IDD6N	Self Refresh IDD Current: Normal Temperature Range	15	15	15	mA
IDD6E	Self Refresh IDD Current: Extended Temperature Range	16	16	16	mA
IDD6R	Self Refresh IDD Current: Reduced Temperature Range	14	14	14	mA
IDD6A	Auto Self Refresh IDD Current	16	16	16	mA
IDD7	Operating Bank Interleave Read Current	173	179	187	mA

Notes:

- Gear-down mode is not supported for speed below DDR4-2666.
- The above Max. values for IDD currents are restricted to TCASE ≤ 85°C.
- The IDD current specification must be derated (increased) as below when operating temperature, TCASE large than 85°C.
 - When 85°C < TCASE ≤ 95°C: IDDQ2NT and IDD5B, must be derated by 10%.
 - When 85°C < TCASE ≤ 95°C: IDD1, IDD4R, IDD4RB, IDDQ4RB, IDD1A, IDD4RA, IDD4WA, IDD4W, IDD4WB, IDD4WC, IDD4W_par, IDD5F2, IDD5F4 and IDD7 must be derated by 20%.
 - When 85°C < TCASE ≤ 95°C: IDD0 and IDD0A must be derated by 30%.
 - When 85°C < TCASE ≤ 95°C: IDD2NT and IDDQ4R must be derated by 40%.
 - When 85°C < TCASE ≤ 95°C: IDD2N, IDD2NL, IDD2NG, IDD2ND, IDD2N_par, IDD2P, IDD2Q, IDD3N, IDD3P, IDD2NA and IDD3NA must be derated by 50%.
 - When TCASE > 95°C: All IDD current specification except IDD6N and IDD6R must be derated (increased) more.
- IDD6N applicable for MR2 settings A7 = 0 and A6 = 0; manual mode with normal temperature range of operation (-40~85°C).
- IDD6E applicable for MR2 settings A7 = 1 and A6 = 0; manual mode with extended temperature range of operation (-40~95°C).
- IDD6R applicable for MR2 settings A7 = 0 and A6 = 1; manual mode with reduced temperature range of operation (-40~45°C). IDD6R is verified by design and characterization, and may not be subject to production test.
- IDD6A applicable for MR2 settings A7 = 1 and A6 = 1; ASR mode (Auto Self Refresh) enabled. IDD6A is typical value.

Publication Release Date: Dec. 26, 2024

Revision: A03



Table 117 – IPP Current Maximum Limits

Symbol	Description	DDR4-2400	DDR4-2666	DDR4-3200	Unit
IPP0	Operating One Bank Active-Precharge IPP Current	6	6	6	mA
IPP1	Operating One Bank Active-Read-Precharge IPP Current	6	6	6	mA
IPP2N	Precharge Standby IPP Current	1	1	1	mA
IPP2P	Precharge Power-Down IPP Current	1	1	1	mA
IPP3N	Active Standby IPP Current	6	6	6	mA
IPP3P	Active Power-Down IPP Current	1	1	1	mA
IPP4R	Operating Burst Read IPP Current	11	11	11	mA
IPP4W	Operating Burst Write IPP Current	11	11	11	mA
IPP5B	Burst Refresh Write IPP Current (1X REF)	17	17	17	mA
IPP5F2	Burst Refresh Write IPP Current (2X REF)	14	14	14	mA
IPP5F4	Burst Refresh Write IPP Current (4X REF)	14	14	14	mA
IPP6N	Self Refresh IPP Current: Normal Temperature Range	1.6	1.6	1.6	mA
IPP6E	Self Refresh IPP Current: Extended Temperature Range	2	2	2	mA
IPP6R	Self Refresh IPP Current: Reduced Temperature Range	1.5	1.5	1.5	mA
IPP6A	Auto Self Refresh IPP Current	2	2	2	mA
IPP7	Operating Bank Interleave Read IPP Current	15	15	15	mA

Notes:

- The above Max. values for IDD currents are restricted to TCASE \leq 85°C.
- The IDD current specification must be derated (increased) as below when operating temperature, TCASE large than 85°C.
 - When 85°C < TCASE \leq 95°C: IPP0, IPP1, IPP2N, IPP2P, IPP3N, IPP3P, IPP4R, IPP4W, IPP5B, IPP5F2, IPP5F4 and IPP7 must be derated by 10%.
 - When TCASE > 95°C: All IDD current specification except IPP6N and IPP6R must be derated (increased) more.
- IPP6N applicable for MR2 settings A7 = 0 and A6 = 0; manual mode with normal temperature range of operation (-40~85°C).
- IPP6E applicable for MR2 settings A7 = 1 and A6 = 0; manual mode with extended temperature range of operation (-40~95°C).
- IPP6R applicable for MR2 settings A7 = 0 and A6 = 1; manual mode with reduced temperature range of operation (-40~45°C). IPP6R is verified by design and characterization, and may not be subject to production test.
- IPP6A applicable for MR2 settings A7 = 1 and A6 = 1; ASR mode (Auto Self Refresh) enabled. IPP6A is typical value.



16. Input/Output Capacitance

Table 118 – DRAM package electrical specifications (x16)

Symbol	Parameter	DDR4-2400, 2666, 3200		Unit	Notes
		min	max		
Z _{IO}	Input/output Zpkg	45	85	Ω	1,2,4,5,10,11
T _{dIO}	Input/output Pkg Delay	14	45	pS	1,3,4,5,11
L _{io}	Input/output Lpkg	-	3.4	nH	11,12
C _{io}	Input/output Cpkg	-	0.82	pF	11,13
Z _{IO DQS}	DQS_t and DQS_c Zpkg	45	85	Ω	1,2,5,10,11
T _{dIO DQS}	DQS_t and DQS_c Pkg Delay	14	45	pS	1,3,5,10,11
L _{io DQS}	DQS Lpkg	-	3.4	nH	11,12
C _{io DQS}	DQS Cpkg	-	0.82	pF	11,13
DZ _{DIO DQS}	Delta Zpkg DQSU_t and DQSU_c	-	10	Ω	1,2,5,7,10
	Delta Zpkg DQSL_t and DQSL_c	-	10	Ω	1,2,5,7,10
D _{TDIO DQS}	Delta Delay DQSU_t and DQSU_c	-	5	pS	1,3,5,7,10
	Delta Delay DQSL_t and DQSL_c	-	5	pS	1,3,5,7,10
Z _{I CTRL}	Input CTRL pins Zpkg	50	90	Ω	1,2,5,9,10,11
T _{dI CTRL}	Input CTRL pins Pkg Delay	14	42	pS	1,3,5,9,10,11
L _{I CTRL}	Input CTRL Lpkg	-	3.4	nH	11,12
C _{I CTRL}	Input CTRL Cpkg	-	0.7	pF	11,13
Z _{I ADD CMD}	Input CMD ADD pins Zpkg	50	90	Ω	1,2,5,8,10,11
T _{dI ADD CMD}	Input CMD ADD pins Pkg Delay	14	52	pS	1,3,5,8,10,11
L _{I ADD CMD}	Input CMD ADD pins Lpkg	-	3.9	nH	11,12
C _{I ADD CMD}	Input CMD ADD pins Cpkg	-	0.86	pF	11,13
Z _{CK}	CK_t and CK_c Zpkg	50	90	Ω	1,2,5,10,11
T _{dCK}	CK_t and CK_c Pkg Delay	14	42	pS	1,3,5,10,11
L _{I CLK}	Input CLK Lpkg	-	3.4	nH	11,12
C _{I CLK}	Input CLK Cpkg	-	0.7	pF	11,13
DZ _{DCK}	Delta Zpkg CK_t and CK_c	-	10	Ω	1,2,5,6,10
D _{TdCK}	Delta Delay CK_t and CK_c	-	5	pS	1,3,5,6,10
Z _{OZQ}	ZQ Zpkg	-	100	Ω	1,2,5,10,11
T _{dO ZQ}	ZQ Delay	20	90	pS	1,3,5,10,11
Z _{O ALERT}	ALERT Zpkg	40	100	Ω	1,2,5,10,11
T _{dO ALERT}	ALERT Delay	20	55	pS	1,3,5,10,11

Notes:

- This parameter is not subject to production test. It is verified by design and characterization. The package parasitic (L and C) are validated using package only samples. The capacitance is measured with VDD, VDDQ, VSS, VSSQ shorted with all other signal pins floating. The inductance is measured with VDD, VDDQ, VSS and VSSQ shorted and all other signal pins shorted at the die side (not pin).
- Package only impedance (Zpkg) is calculated based on the Lpkg and Cpkg total for a given pin where:

$$Z_{pkg} \text{ (total per pin)} = \sqrt{L_{pkg}/C_{pkg}}$$
- Package only delay (Tpkg) is calculated based on Lpkg and Cpkg total for a given pin where:

$$T_{pkg} \text{ (total per pin)} = \sqrt{L_{pkg} * C_{pkg}}$$
- Z_{IO} and T_{dIO} apply to DQ and DM.
- This parameter applies to monolithic devices only; stacked/dual-die devices are not covered here.
- Absolute value of ZCK_t-ZCK_c for impedance (Z) or absolute value of TdCK_t-TdCK_c for delay (Td).
- Absolute value of ZIO(DQS_t)-ZIO(DQS_c) for impedance (Z) or absolute value of TdIO(DQS_t)-TdIO(DQS_c) for delay (Td).
- ZI & Td ADD CMD applies to A0-A13, ACT_n, BA0-BA1, BG0, RAS_n/A16, CAS_n/A15, WE_n/A14 and PAR.
- ZI & Td CTRL applies to ODT, CS_n and CKE.
- This table applies to monolithic x16 devices.
- Package implementations shall meet spec if the Zpkg and Pkg Delay fall within the ranges shown, and the maximum Lpkg and Cpkg do not exceed the maximum values shown.
- It is assumed that Lpkg can be approximated as Lpkg = Zo*Td.
- It is assumed that Cpkg can be approximated as Cpkg = Td/Zo.



17. Electrical Characteristics and AC Timing

17.1 Reference Load for AC Timing and Output Slew Rate

Figure 197 represents the effective reference load of 50 ohms used in defining the relevant AC timing parameters of the device as well as output slew rate measurements.

Ron nominal of DQ, DQS_t and DQS_c drivers uses 34 ohms to specify the relevant AC timing parameter values of the device.

The maximum DC High level of Output signal = 1.0 * VDDQ,

The minimum DC Low level of Output signal = $\{34/(34 + 50)\} * VDDQ = 0.4 * VDDQ$

The nominal reference level of an Output signal can be approximated by the following:

The center of maximum DC High and minimum DC Low = $\{(1 + 0.4)/2\} * VDDQ = 0.7 * VDDQ$

The actual reference level of Output signal might vary with driver Ron and reference load tolerances. Thus, the actual reference level or midpoint of an output signal is at the widest part of the output signal's eye. Prior to measuring AC parameters, the reference level of the verification tool should be set to an appropriate level.

It is not intended as a precise representation of any particular system environment or a depiction of the actual load presented by a production tester. System designers should use IBIS or other simulation tools to correlate the timing reference load to a system environment. Manufacturers correlate to their production test conditions, generally one or more coaxial transmission lines terminated at the tester electronics.

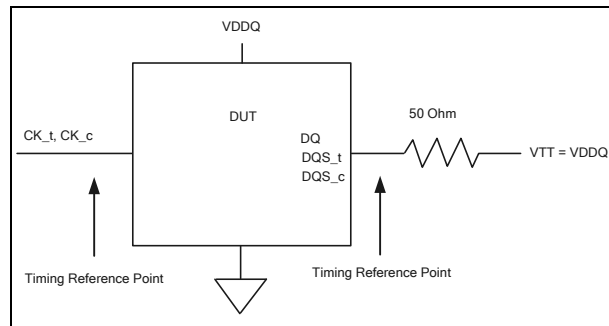

Figure 197 – Reference Load for AC Timing and Output Slew Rate

17.2 tREFI

Average periodic Refresh interval (tREFI) of DDR4 SDRAM is defined as shown in below table.

Table 119 – tREFI refresh timing

Parameter	Symbol	4Gb	Units	
Average periodic refresh interval	tREFI	-40°C ≤ TCASE ≤ 85°C	7.8	μS
		85°C < TCASE ≤ 95°C	3.9	μS
		95°C < TCASE ≤ 105°C	1.95	μS



17.2.1 Operating Temperature Condition

Parameter	Symbol	Rating	Unit	Notes
Commercial grade parts operating temperature range (for -06/-07/-08)	TOPER	0 ~ 85	°C	1, 2
		0 ~ 95	°C	1, 2, 4
Industrial grade parts operating temperature range (for 06I/07I/08I)	TOPER	-40 ~ 85	°C	1, 3
		-40 ~ 95	°C	1, 3, 4
Industrial Plus grade parts operating temperature range (for 06J/07J/08J)	TOPER	-40 ~ 85	°C	1, 3
		-40 ~ 105	°C	1, 3, 4

Notes:

- Operating Temperature TOPER is the case surface temperature on the center / top side of the DRAM. For measurement conditions, please refer to the JEDEC document JESD51-2.
- During operation, the DRAM case temperature must be maintained between 0 to 95°C for Commercial parts under all specification parameters.
- During operation, the DRAM case temperature must be maintained between -40 to 95°C for Industrial parts and -40 to 105°C for Industrial Plus parts under all specification parameters.
- Some applications require operation of the 85°C < TCASE ≤ 105°C operating temperature. Full specifications are provided in this range, but the following additional conditions apply:
 - If Self-Refresh operation is required in 85°C < TCASE ≤ 105°C operating temperature range, than it is mandatory to either use the disable Temperature Controlled Refresh mode with Extended Temperature Range capability (MR4 A3 = 0_b and MR4 A2 = 1_b) or enable the Temperature Controlled Refresh mode (MR4 A3 = 1_b, MR4 A2 = 1_b).
 - In 85°C < TCASE ≤ 95°C, with Refresh commands in frequency to a 32 mS period (tREFI = 3.9 μS).
 - In 95°C < TCASE ≤ 105°C, with Refresh commands in frequency to a 16 mS period (tREFI = 1.95 μS).

17.3 Clock Specification

The jitter specified is a random jitter meeting a Gaussian distribution. Input clocks violating the min/max values may result in malfunction of the DDR4 SDRAM device.

Definition for tCK(abs)

tCK(abs) is defined as the absolute clock period, as measured from one rising edge to the next consecutive rising edge. tCK(abs) is not subject to production test.

Definition for tCK(avg)

tCK(avg) is calculated as the average clock period across any consecutive 200 cycle window, where each clock period is calculated from rising edge to rising edge.

$$tCK(avg) = \left[\sum_{j=1}^N tCK(abs)_j \right] / N \quad N = 200$$

Definition for tCH(avg) and tCL(avg)

tCH(avg) is defined as the average high pulse width, as calculated across any consecutive 200 high pulses.

$$tCH(avg) = \left[\sum_{j=1}^N tCH_j \right] / \{N \times tCK(avg)\} \quad N = 200$$

tCL(avg) is defined as the average low pulse width, as calculated across any consecutive 200 low pulses.

$$tCL(avg) = \left[\sum_{j=1}^N tCL_j \right] / \{N \times tCK(avg)\} \quad N = 200$$

Definition for tERR(nper)

tERR is defined as the cumulative error across n consecutive cycles of n x tCK(avg). tERR is not subject to production test.



17.4 Timing Parameters by Speed Grade

Table 120 – Timing Parameters by Speed Grade for DDR4-1600 to DDR4-2400

Speed		DDR4-1600		DDR4-1866		DDR4-2133		DDR4-2400		Units	Notes
Parameter	Symbol	Min.	Max.	Min.	Max.	Min.	Max.	Min.	Max.		
Clock Timing											
Minimum clock cycle time (DLL-off mode)	tCK(DLL-off)	8	20	8	20	8	20	8	20	nS	
Average Clock Period	tCK(avg)	1.25	< 1.5	1.071	< 1.25	0.937	< 1.071	0.833	< 0.937	nS	35,36
Average high pulse width	tCH(avg)	0.48	0.52	0.48	0.52	0.48	0.52	0.48	0.52	tCK(avg)	
Average low pulse width	tCL(avg)	0.48	0.52	0.48	0.52	0.48	0.52	0.48	0.52	tCK(avg)	
Absolute Clock Period	tCK(abs)	Min. = tCK(avg)min + tJIT(per)min_tot Max. = tCK(avg)max + tJIT(per)max_tot								pS	
Absolute clock high pulse width	tCH(abs)	0.45	–	0.45	–	0.45	–	0.45	–	tCK(avg)	23
Absolute clock low pulse width	tCL(abs)	0.45	–	0.45	–	0.45	–	0.45	–	tCK(avg)	24
Clock Period Jitter – total	tJIT(per)_tot	-63	63	-54	54	-47	47	-42	42	pS	23
Clock Period Jitter – deterministic	tJIT(per)_dj	-31	31	-27	27	-23	23	-21	21	pS	26
Clock Period Jitter during DLL locking period	tJIT(per)_lck	-50	50	-43	43	-38	38	-33	33	pS	
Cycle to Cycle Period Jitter	tJIT(cc)	–	125	–	107	–	94	–	83	pS	
Cycle to Cycle Period Jitter during DLL locking period	tJIT(cc)_lck	–	100	–	86	–	75	–	67	pS	
Cumulative error across 2 cycles	tERR(2per)	-92	92	-79	79	-69	69	-61	61	pS	
Cumulative error across 3 cycles	tERR(3per)	-109	109	-94	94	-82	82	-73	73	pS	
Cumulative error across 4 cycles	tERR(4per)	-121	121	-104	104	-91	91	-81	81	pS	
Cumulative error across 5 cycles	tERR(5per)	-131	131	-112	112	-98	98	-87	87	pS	
Cumulative error across 6 cycles	tERR(6per)	-139	139	-119	119	-104	104	-92	92	pS	
Cumulative error across 7 cycles	tERR(7per)	-145	145	-124	124	-109	109	-97	97	pS	
Cumulative error across 8 cycles	tERR(8per)	-151	151	-129	129	-113	113	-101	101	pS	
Cumulative error across 9 cycles	tERR(9per)	-156	156	-134	134	-117	117	-104	104	pS	
Cumulative error across 10 cycles	tERR(10per)	-160	160	-137	137	-120	120	-107	107	pS	
Cumulative error across 11 cycles	tERR(11per)	-164	164	-141	141	-123	123	-110	110	pS	
Cumulative error across 12 cycles	tERR(12per)	-168	168	-144	144	-126	126	-112	112	pS	
Cumulative error across 13 cycles	tERR(13per)	-172	172	-147	147	-129	129	-114	114	pS	
Cumulative error across 14 cycles	tERR(14per)	-175	175	-150	150	-131	131	-116	116	pS	
Cumulative error across 15 cycles	tERR(15per)	-178	178	-152	152	-133	133	-118	118	pS	



Speed		DDR4-1600		DDR4-1866		DDR4-2133		DDR4-2400		Units	Notes
Parameter	Symbol	Min.	Max.	Min.	Max.	Min.	Max.	Min.	Max.		
Cumulative error across 16 cycles	tERR(16per)	-180	180	-155	155	-135	135	-120	120	pS	
Cumulative error across 17 cycles	tERR(17per)	-183	183	-157	157	-137	137	-122	122	pS	
Cumulative error across 18 cycles	tERR(18per)	-185	185	-159	159	-139	139	-124	124	pS	
Cumulative error across n = 13, 14...49, 50 cycles	tERR(nper)	Min. = $((1 + 0.68\ln(n)) * tJIT(per_total\ min))$ Max. = $((1 + 0.68\ln(n)) * tJIT(per_total\ max))$								pS	
Command and Address Timing											
Command and Address setup time to CK_t, CK_c referenced to Vih(ac) / Vil(ac) levels	tIS(base)	115	-	100	-	80	-	62	-	pS	
Command and Address setup time to CK_t, CK_c referenced to Vref levels	tIS(Vref)	215	-	200	-	180	-	162	-	pS	
Command and Address hold time to CK_t, CK_c referenced to Vih(dc) / Vil(dc) levels	tIH(base)	140	-	125	-	105	-	87	-	pS	
Command and Address hold time to CK_t, CK_c referenced to Vref levels	tIH(Vref)	215	-	200	-	180	-	162	-	pS	
Control and Address Input pulse width for each input	tIPW	600	-	525	-	460	-	410	-	pS	
CAS_n to CAS_n command delay for same bank group	tCCD_L	Max(5nCK, 6.250nS)	-	Max(5nCK, 5.355nS)	-	Max(5nCK, 5.355nS)	-	Max(5nCK, 5nS)	-	nCK	34
CAS_n to CAS_n command delay for different bank group	tCCD_S	4	-	4	-	4	-	4	-	nCK	34
ACTIVATE to ACTIVATE Command delay to different bank group for 2KB page size	tRRD_S(2K)	Max(4nCK, 6nS)	-	Max(4nCK, 5.3nS)	-	Max(4nCK, 5.3nS)	-	Max(4nCK, 5.3nS)	-	nCK	34
ACTIVATE to ACTIVATE Command delay to same bank group for 2KB page size	tRRD_L(2K)	Max(4nCK, 7.5nS)	-	Max(4nCK, 6.4nS)	-	Max(4nCK, 6.4nS)	-	Max(4nCK, 6.4nS)	-	nCK	34
Four activate window for 2KB page size	tFAW_2K	Max(28nCK, 35nS)	-	Max(28nCK, 30nS)	-	Max(28nCK, 30nS)	-	Max(28nCK, 30nS)	-	nS	34
Delay from start of internal write transaction to internal read command for different bank group	tWTR_S	Max(2nCK, 2.5nS)	-	Max(2nCK, 2.5nS)	-	Max(2nCK, 2.5nS)	-	Max(2nCK, 2.5nS)	-		1,2,34
Delay from start of internal write transaction to internal read command for same bank group	tWTR_L	Max(4nCK, 7.5nS)	-	Max(4nCK, 7.5nS)	-	Max(4nCK, 7.5nS)	-	Max(4nCK, 7.5nS)	-		1,34
Internal READ Command to PRECHARGE Command delay	tRTP	Max(4nCK, 7.5nS)	-	Max(4nCK, 7.5nS)	-	Max(4nCK, 7.5nS)	-	Max(4nCK, 7.5nS)	-		
WRITE recovery time	tWR	15	-	15	-	15	-	15	-	nS	1
Write recovery time when CRC and DM are enabled	tWR_CRC_DM	tWR + max(4nCK, 3.75nS)	-	tWR + max(5nCK, 3.75nS)	-	tWR + max(5nCK, 3.75nS)	-	tWR + max(5nCK, 3.75nS)	-	nS	1,28



Speed		DDR4-1600		DDR4-1866		DDR4-2133		DDR4-2400		Units	Notes
Parameter	Symbol	Min.	Max.	Min.	Max.	Min.	Max.	Min.	Max.		
Delay from start of internal write transaction to internal read command for different bank group with both CRC and DM enabled	tWTR_S_CRC_DM	tWTR_S + max(4nCK, 3.75nS)	-	tWTR_S + max(5nCK, 3.75nS)	-	tWTR_S + max(5nCK, 3.75nS)	-	tWTR_S + max(5nCK, 3.75nS)	-	nS	2,29,34
Delay from start of internal write transaction to internal read command for same bank group with both CRC and DM enabled	tWTR_L_CRC_DM	tWTR_L + max(4nCK, 3.75nS)	-	tWTR_L + max(5nCK, 3.75nS)	-	tWTR_L + max(5nCK, 3.75nS)	-	tWTR_L + max(5nCK, 3.75nS)	-	nS	3,30,34
DLL locking time	tDLLK	597	-	597	-	768	-	768	-	nCK	
Mode Register Set command cycle time	tMRD	8	-	8	-	8	-	8	-	nCK	
Mode Register Set command update delay	tMOD	Max(24nCK, 15nS)	-	Max(24nCK, 15nS)	-	Max(24nCK, 15ns)	-	Max(24nCK, 15ns)	-	-	50
Multi-Purpose Register Recovery Time	tMPRR	1	-	1	-	1	-	1	-	nCK	33
Multi-Purpose Register Write Recovery Time	tWR_MPR	tMOD(min) + AL + PL	-	tMOD(min) + AL + PL	-	tMOD(min) + AL + PL	-	tMOD(min) + AL + PL	-	-	
Auto precharge write recovery + precharge time	tDAL(min)	Programmed WR + roundup (tRP/tCK(avg))								nCK	51
DQL0 driven to 0 setup time to first DQS rising edge	tPDA_S	0.5	-	0.5	-	0.5	-	0.5	-	UI	45,47
DQL0 driven to 0 hold time from last DQS falling edge	tPDA_H	0.5	-	0.5	-	0.5	-	0.5	-	UI	46,47
CS_n to Command Address Latency											
CS_n to Command Address Latency	tCAL	Max(3nCK, 3.748nS)	-	Max(3nCK, 3.748nS)	-	Max(3nCK, 3.748nS)	-	Max(3nCK, 3.748nS)	-	nCK	
Mode Register Set command cycle time in CAL mode	tMRD_tCAL	tMOD + tCAL	-	tMOD + tCAL	-	tMOD + tCAL	-	tMOD + tCAL	-	nCK	
Mode Register Set update delay in CAL mode	tMOD_tCAL	tMOD + tCAL	-	tMOD + tCAL	-	tMOD + tCAL	-	tMOD + tCAL	-	nCK	
DRAM Data Timing											
DQS_t, DQS_c to DQ skew, per group, per access	tDQSQ	-	0.16	-	0.16	-	0.16	-	0.17	tCK(avg)/2	13,18,39,49
DQ output hold time per group, per access from DQS_t, DQS_c	tQH	0.76	-	0.76	-	0.76	-	0.74	-	tCK(avg)/2	13,17,18,39,49
Data Valid Window per device per UI: (tQH - tDQSQ) of each UI on a given DRAM	tDVWd	0.63	-	0.63	-	0.64	-	0.64	-	UI	17,18,39,49
Data Valid Window per pin per UI: (tQH - tDQSQ) each UI on a pin of a given DRAM	tDVWp	0.66	-	0.66	-	0.69	-	0.72	-	UI	17,18,39,49
DQ low impedance time from CK_t, CK_c	tLZ(DQ)	-450	225	-390	195	-360	180	-330	175	pS	39
DQ high impedance time from CK_t, CK_c	tHZ(DQ)	-	225	-	195	-	180	-	175	pS	39
Data Strobe Timing											
DQS_t, DQS_c differential READ Preamble (1 clock preamble)	tRPRE	0.9	Note 44	0.9	Note 44	0.9	Note 44	0.9	Note 44	tCK	40
DQS_t, DQS_c differential READ Preamble (2 clock preamble)	tRPRE2	NA	NA	NA	NA	NA	NA	1.8	Note 44	tCK	41



Speed		DDR4-1600		DDR4-1866		DDR4-2133		DDR4-2400		Units	Notes
Parameter	Symbol	Min.	Max.	Min.	Max.	Min.	Max.	Min.	Max.		
DQS_t, DQS_c differential READ Postamble	tRPST	0.33	Note 45	0.33	Note 45	0.33	Note 45	0.33	Note 45	tCK	
DQS_t, DQS_c differential output high time	tQSH	0.4	-	0.4	-	0.4	-	0.4	-	tCK	21
DQS_t, DQS_c differential output low time	tQSL	0.4	-	0.4	-	0.4	-	0.4	-	tCK	20
DQS_t, DQS_c differential WRITE Preamble (1 clock preamble)	tWPRE	0.9	-	0.9	-	0.9	-	0.9	-	tCK	42
DQS_t, DQS_c differential WRITE Preamble (2 clock preamble)	tWPRE2	NA	-	NA	-	NA	-	1.8	-	tCK	43
DQS_t, DQS_c differential WRITE Postamble	tWPST	0.33	-	0.33	-	0.33	-	0.33	-	tCK	
DQS_t and DQS_c low impedance time (Referenced from RL-1)	tLZ(DQS)	-450	225	-390	195	-360	180	-330	175	pS	39
DQS_t and DQS_c high impedance time (Referenced from RL+BL/2)	tHZ(DQS)	-	225	-	195	-	180	-	175	pS	39
DQS_t, DQS_c differential input low pulse width	tDQSL	0.46	0.54	0.46	0.54	0.46	0.54	0.46	0.54	tCK	
DQS_t, DQS_c differential input high pulse width	tDQSH	0.46	0.54	0.46	0.54	0.46	0.54	0.46	0.54	tCK	
DQS_t, DQS_c rising edge to CK_t, CK_c rising edge (1 clock preamble)	tDQSS	-0.27	0.27	-0.27	0.27	-0.27	0.27	-0.27	0.27	tCK	42
DQS_t, DQS_c rising edge to CK_t, CK_c rising edge (2 clock preamble)	tDQSS2	NA	NA	NA	NA	NA	NA	-0.50	0.50	tCK	43
DQS_t, DQS_c falling edge setup time to CK_t, CK_c rising edge	tDSS	0.18	-	0.18	-	0.18	-	0.18	-	tCK	
DQS_t, DQS_c falling edge hold time from CK_t, CK_c rising edge	tDSH	0.18	-	0.18	-	0.18	-	0.18	-	tCK	
DQS_t, DQS_c rising edge output timing location from rising CK_t, CK_c with DLL On mode	tDQSCK (DLL On)	-225	225	-195	195	-180	180	-175	175	pS	37,38,39
DQS_t, DQS_c rising edge output variance window per DRAM	tDQSCKI (DLL On)	-	370	-	330	-	310	-	290	pS	37,38,39
Calibration Timing											
Power-up and RESET calibration time	tZQinit	1024	-	1024	-	1024	-	1024	-	nCK	
Normal operation Full calibration time	tZQoper	512	-	512	-	512	-	512	-	nCK	
Normal operation Short calibration time	tZQCS	128	-	128	-	128	-	128	-	nCK	
Reset/Self Refresh Timing											
Exit Reset from CKE HIGH to a valid command	tXPR	max(5nCK, tRFC(min) + 10nS)	-	max(5nCK, tRFC(min) + 10nS)	-	max(5nCK, tRFC(min) + 10nS)	-	max(5nCK, tRFC(min) + 10nS)	-		
Exit Self Refresh to commands not requiring a locked DLL	tXS	tRFC(min) + 10nS	-	tRFC(min) + 10nS	-	tRFC(min) + 10nS	-	tRFC(min) + 10nS	-		



Speed		DDR4-1600		DDR4-1866		DDR4-2133		DDR4-2400		Units	Notes
Parameter	Symbol	Min.	Max.	Min.	Max.	Min.	Max.	Min.	Max.		
SRX to commands not requiring a locked DLL in Self Refresh ABORT	tXS_ABORT (min)	tRFC4(min) + 10nS	-	tRFC4(min) + 10nS	-	tRFC4(min) + 10nS	-	tRFC4(min) + 10nS	-		
Exit Self Refresh to ZQCL, ZQCS and MRS (CL,CWL,WR,RTP)	tXS_FAST (min)	tRFC4(min) + 10nS	-	tRFC4(min) + 10nS	-	tRFC4(min) + 10nS	-	tRFC4(min) + 10nS	-		
Exit Self Refresh to commands requiring a locked DLL	tXSDLL	tDLLK(min)	-	tDLLK(min)	-	tDLLK(min)	-	tDLLK(min)	-		
Minimum CKE low width for Self refresh entry to exit timing	tCKESR	tCKE(min)+ 1nCK	-	tCKE(min)+ 1nCK	-	tCKE(min)+ 1nCK	-	tCKE(min)+ 1nCK	-		
Minimum CKE low width for Self refresh entry to exit timing with CA Parity enabled	tCKESR_PAR	tCKE(min)+ 1nCK + PL	-	tCKE(min)+ 1nCK + PL	-	tCKE(min)+ 1nCK + PL	-	tCKE(min)+ 1nCK + PL	-		
Valid Clock Requirement after Self Refresh Entry (SRE) or Power-Down Entry (PDE)	tCKSRE	max(5nCK, 10nS)	-	max(5nCK, 10nS)	-	max(5nCK, 10nS)	-	max(5nCK, 10nS)	-		
Valid Clock Requirement after Self Refresh Entry (SRE) or Power-Down when CA Parity is enabled	tCKSRE_PAR	max(5nCK, 10nS) + PL	-	max(5nCK, 10nS) + PL	-	max(5nCK, 10nS) + PL	-	max(5nCK, 10nS) + PL	-		
Valid Clock Requirement before Self Refresh Exit (SRX) or Power-Down Exit (PDX) or Rese Exit	tCKSRX	max(5nCK, 10nS)	-	max(5nCK, 10nS)	-	max(5nCK, 10nS)	-	max(5nCK, 10nS)	-		
Power Down Timing											
Exit Power Down with DLL on to any valid command; Exit Precharge Power Down with DLL frozen to commands not requiring a locked DLL	tXP	max(4nCK, 6nS)	-	max(4nCK, 6nS)	-	max(4nCK, 6nS)	-	max(4nCK, 6nS)	-		
CKE minimum pulse width	tCKE	max(3nCK, 5nS)	-	max(3nCK, 5nS)	-	max(3nCK, 5nS)	-	max(3nCK, 5nS)	-		31,32
Command pass disable delay	tCPDED	4	-	4	-	4	-	4	-	nCK	
Power Down Entry to Exit Timing	tPD	tCKE(min)	9*tREFI	tCKE(min)	9*tREFI	tCKE(min)	9*tREFI	tCKE(min)	9*tREFI		6
Timing of ACT command to Power Down entry	tACTPDEN	1	-	1	-	2	-	2	-	nCK	7
Timing of PRE or PREA command to Power Down entry	tPRPDEN	1	-	1	-	2	-	2	-	nCK	7
Timing of RD/RDA command to Power Down entry	tRDPDEN	RL + 4 + 1	-	RL + 4 + 1	-	RL + 4 + 1	-	RL + 4 + 1	-	nCK	
Timing of WR command to Power Down entry (BL8OTF, BL8MRS, BC4OTF)	tWRPDEN	WL+4+(tWR /tCK(avg))	-	WL+4+(tWR /tCK(avg))	-	WL+4+(tWR /tCK(avg))	-	WL+4+(tWR /tCK(avg))	-	nCK	4
Timing of WRA command to Power Down entry (BL8OTF, BL8MRS, BC4OTF)	tWRAPDEN	WL + 4 + WR + 1	-	WL + 4 + WR + 1	-	WL + 4 + WR + 1	-	WL + 4 + WR + 1	-	nCK	5
Timing of WR command to Power Down entry (BC4MRS)	tWRPBC4DEN	WL+2+(tWR /tCK(avg))	-	WL+2+(tWR /tCK(avg))	-	WL+2+(tWR /tCK(avg))	-	WL+2+(tWR /tCK(avg))	-	nCK	4



Speed		DDR4-1600		DDR4-1866		DDR4-2133		DDR4-2400		Units	Notes
Parameter	Symbol	Min.	Max.	Min.	Max.	Min.	Max.	Min.	Max.		
Timing of WRA command to Power Down entry (BC4MRS)	tWRAPBC4DEN	WL + 2 + WR + 1	-	WL + 2 + WR + 1	-	WL + 2 + WR + 1	-	WL + 2 + WR + 1	-	nCK	5
Timing of REF command to Power Down entry	tREFPDEN	1	-	1	-	2	-	2	-	nCK	7
Timing of MRS command to Power Down entry	tMRSPDEN	tMOD(min)	-	tMOD(min)	-	tMOD(min)	-	tMOD(min)	-		
PDA Timing											
Mode Register Set command cycle time in PDA mode	tMRD_PDA	max(16nCK, 10nS)	-	max(16nCK, 10nS)	-	max(16nCK, 10nS)	-	max(16nCK, 10nS)	-	nCK	
Mode Register Set command update delay in PDA mode	tMOD_PDA	tMOD		tMOD		tMOD		tMOD		nCK	
ODT Timing											
Asynchronous RTT turn-on delay (Power-Down with DLL frozen)	tAONAS	1.0	9.0	1.0	9.0	1.0	9.0	1.0	9.0	nS	
Asynchronous RTT turn-off delay (Power-Down with DLL frozen)	tAOFAS	1.0	9.0	1.0	9.0	1.0	9.0	1.0	9.0	nS	
RTT dynamic change skew	tADC	0.3	0.7	0.3	0.7	0.3	0.7	0.3	0.7	tCK(avg)	
Write Leveling Timing											
First DQS_t/DQS_c rising edge after write leveling mode is programmed	tWLMRD	40	-	40	-	40	-	40	-	nCK	12
DQS_t/DQS_c delay after write leveling mode is programmed	tWLDQSEN	25	-	25	-	25	-	25	-	nCK	12
Write leveling setup time from rising CK_t, CK_c crossing to rising DQS_t/DQS_c crossing	twLS	0.13	-	0.13	-	0.13	-	0.13	-	tCK(avg)	
Write leveling hold time from rising DQS_t/DQS_c crossing to rising CK_t, CK_c crossing	twLH	0.13	-	0.13	-	0.13	-	0.13	-	tCK(avg)	
Write leveling output delay	twLO	0	9.5	0	9.5	0	9.5	0	9.5	nS	
Write leveling output error	twLOE	0	2	0	2	0	2	0	2	nS	
CA Parity Timing											
Commands not guaranteed to be executed during this time	tPAR_UNKN OWN	-	PL	-	PL	-	PL	-	PL		
Delay from errant command to ALERT_n assertion	tPAR_ALERT _ON	-	PL + 6nS	-	PL + 6nS	-	PL + 6nS	-	PL + 6nS		
Pulse width of ALERT_n signal when asserted	tPAR_ALERT _PW	48	96	56	112	64	128	72	144	nCK	
Time from when Alert is asserted till controller must start providing DES commands in Persistent CA parity mode	tPAR_ALERT _RSP	-	43	-	50	-	57	-	64	nCK	
Parity Latency	PL	4		4		4		5		nCK	
CRC Error Reporting											
CRC error to ALERT_n latency	tCRC_ALERT	3	13	3	13	3	13	3	13	nS	



Speed		DDR4-1600		DDR4-1866		DDR4-2133		DDR4-2400		Units	Notes
Parameter	Symbol	Min.	Max.	Min.	Max.	Min.	Max.	Min.	Max.		
CRC ALERT_n pulse width	CRC_ALERT_PW	6	10	6	10	6	10	6	10	nCK	
tREFI											
tRFC1 (min)	4Gb	260	-	260	-	260	-	260	-	nS	34
tRFC2 (min)	4Gb	160	-	160	-	160	-	160	-	nS	34
tRFC4 (min)	4Gb	110	-	110	-	110	-	110	-	nS	34



Table 121 – Timing Parameters by Speed Grade for DDR4-2666 and DDR4-3200

Speed		DDR4-2666		DDR4-3200		Units	Notes
Parameter	Symbol	Min.	Max.	Min.	Max.		
Clock Timing							
Minimum clock cycle time (DLL-off mode)	tCK(DLL-off)	8	20	8	20	nS	
Average Clock Period	tCK(avg)	0.75	< 0.833	0.625	< 0.682	nS	35, 36
Average high pulse width	tCH(avg)	0.48	0.52	0.48	0.52	tCK(avg)	
Average low pulse width	tCL(avg)	0.48	0.52	0.48	0.52	tCK(avg)	
Absolute Clock Period	tCK(abs)	Min. = tCK(avg)min + tJIT(per)min_tot Max. = tCK(avg)max + tJIT(per)max_tot				pS	
Absolute Clock high pulse width	tCH(abs)	0.45	-	0.45	-	tCK(avg)	23
Absolute Clock low pulse width	tCL(abs)	0.45	-	0.45	-	tCK(avg)	24
Clock Period Jitter – total	tJIT(per)_tot	-38	38	-32	32	pS	25
Clock Period Jitter – deterministic	tJIT(per)_dj	-19	19	-16	16	pS	26
Clock Period Jitter during DLL locking period	tJIT(per,lck)	-30	30	-25	25	pS	
Cycle to Cycle Period Jitter	tJIT(cc)	-	75	-	62	pS	
Cycle to Cycle Period Jitter during DLL locking period	tJIT(cc,lck)	-	60	-	50	pS	
Cumulative error across 2 cycles	tERR(2per)	-55	55	-46	46	pS	
Cumulative error across 3 cycles	tERR(3per)	-66	66	-55	55	pS	
Cumulative error across 4 cycles	tERR(4per)	-73	73	-61	61	pS	
Cumulative error across 5 cycles	tERR(5per)	-78	78	-65	65	pS	
Cumulative error across 6 cycles	tERR(6per)	-83	83	-69	69	pS	
Cumulative error across 7 cycles	tERR(7per)	-87	87	-73	73	pS	
Cumulative error across 8 cycles	tERR(8per)	-91	91	-76	76	pS	
Cumulative error across 9 cycles	tERR(9per)	-94	94	-78	78	pS	
Cumulative error across 10 cycles	tERR(10per)	-96	96	-80	80	pS	
Cumulative error across 11 cycles	tERR(11per)	-99	99	-83	83	pS	
Cumulative error across 12 cycles	tERR(12per)	-101	101	-84	84	pS	
Cumulative error across 13 cycles	tERR(13per)	-103	103	-86	86	pS	
Cumulative error across 14 cycles	tERR(14per)	-104	104	-87	87	pS	
Cumulative error across 15 cycles	tERR(15per)	-106	106	-89	89	pS	
Cumulative error across 16 cycles	tERR(16per)	-108	108	-90	90	pS	
Cumulative error across 17 cycles	tERR(17per)	-110	110	-92	92	pS	
Cumulative error across 18 cycles	tERR(18per)	-112	112	-93	93	pS	
Cumulative error across n = 13, 14...49, 50 cycles	tERR(nper)	Min. = ((1 + 0.68ln(n)) * tJIT(per)_total min) Max. = ((1 + 0.68ln(n)) * tJIT(per)_total max)				pS	
Command and Address Timing							
Command and Address setup time to CK_t, CK_c referenced to Vih(ac) / Vil(ac) levels	tIS(base)	55	-	40	-	pS	
Command and Address setup time to CK_t, CK_c referenced to VREF levels	tIS(VREF)	145	-	130	-	pS	
Command and Address hold time to CK_t, CK_c referenced to Vih(dc) / Vil(dc) levels	tIH(base)	80	-	65	-	pS	
Command and Address hold time to CK_t, CK_c referenced to VREF levels	tIH(VREF)	145	-	130	-	pS	



Speed		DDR4-2666		DDR4-3200		Units	Notes	
Parameter	Symbol	Min.	Max.	Min.	Max.			
Control and Address Input pulse width for each input	tIPW	385	-	340	-	pS		
CAS_n to CAS_n command delay for same bank group	tCCD_L	Max(5nCK, 5nS)	-	Max(5nCK, 5nS)	-	nCK	34	
CAS_n to CAS_n command delay for different bank group	tCCD_S	4	-	4	-	nCK	34	
ACTIVATE to ACTIVATE Command delay to different bank group for 2KB page size	tRRD_S(2K)	Max(4nCK, 5.3nS)	-	Max(4nCK, 5.3nS)	-	nCK	34	
ACTIVATE to ACTIVATE Command delay to same bank group for 2KB page size	tRRD_L(2K)	Max(4nCK, 6.4nS)	-	Max(4nCK, 6.4nS)	-	nCK	34	
Four activate window for 2KB page size	tFAW_2K	Max(28nCK, 30nS)	-	Max(28nCK, 30nS)	-	nS	34	
Delay from start of internal write transaction to internal read command for different bank group	tWTR_S	Max(2nCK, 2.5nS)	-	Max(2nCK, 2.5nS)	-		1, 2, 34	
Delay from start of internal write transaction to internal read command for same bank group	tWTR_L	Max(4nCK, 7.5nS)	-	Max(4nCK, 7.5nS)	-		1, 34	
Internal READ Command to PRECHARGE Command delay	tRTP	Max(4nCK, 7.5nS)	-	Max(4nCK, 7.5nS)	-			
WRITE recovery time	tWR	15	-	15	-	nS	1	
Write recovery time when CRC and DM are enabled	tWR_CRC_DM	tWR + max(5nCK, 3.75nS)	-	tWR + max(5nCK, 3.75nS)	-	nS	1, 28	
Delay from start of internal write transaction to internal read command for different bank group with both CRC and DM enabled	tWTR_S_CRC_DM	tWTR_S + max(5nCK, 3.75nS)	-	tWTR_S + max(5nCK, 3.75nS)	-	nS	2, 29, 34	
Delay from start of internal write transaction to internal read command for same bank group with both CRC and DM enabled	tWTR_L_CRC_DM	tWTR_L + max(5nCK, 3.75nS)	-	tWTR_L + max(5nCK, 3.75nS)	-	nS	3, 30, 34	
DLL locking time	tDLLK	1024	-	1024	-	nCK		
Mode Register Set command cycle time	tMRD	8	-	8	-	nCK		
Mode Register Set command update delay	tMOD	Max(24nCK, 15nS)	-	Max(24nCK, 15nS)	-	nCK	50	
Multi-Purpose Register Recovery Time	tMPRR	1	-	1	-	nCK	33	
Multi-Purpose Register Write Recovery Time	tWR_MPR	tMOD(min) + AL + PL	-	tMOD(min) + AL + PL	-	nCK		
Auto precharge write recovery + precharge time	tDAL(min)	Programmed WR + roundup (tRP/tCK(avg))					nCK	51
DQL0 driven to 0 setup time to first DQS rising edge	tPDA_S	0.5	-	0.5	-	UI	45, 47	
DQL0 driven to 0 hold time from last DQS falling edge	tPDA_H	0.5	-	0.5	-	UI	46, 47	
CS_n to Command Address Latency								
CS_n to Command Address Latency	tCAL	Max(3nCK, 3.748nS)	-	Max(3nCK, 3.748nS)	-	nCK		
Mode Register Set command cycle time in CAL mode	tMRD_tCAL	tMOD + tCAL	-	tMOD + tCAL	-	nCK		
Mode Register Set update delay in CAL mode	tMOD_tCAL	tMOD + tCAL	-	tMOD + tCAL	-	nCK		



Speed		DDR4-2666		DDR4-3200		Units	Notes
Parameter	Symbol	Min.	Max.	Min.	Max.		
DRAM Data Timing							
DQS_t, DQS_c to DQ skew, per group, per access	tDQSQ	-	0.18	-	0.20	tCK(avg)/2	13, 18, 39, 49
DQ output hold time per group, per access from DQS_t, DQS_c	tQH	0.74	-	0.70	-	tCK(avg)/2	13, 17, 18, 39, 49
Data Valid Window per device per UI: (tQH - tDQSQ) of each UI on a given DRAM	tDVWd	0.64	-	0.64	-	UI	17, 18, 39, 49
Data Valid Window per pin per UI: (tQH - tDQSQ) each UI on a pin of a given DRAM	tDVWp	0.72	-	0.72	-	UI	17, 18, 39, 49
DQ low impedance time from CK_t, CK_c	tLZ(DQ)	-310	170	-250	160	pS	39
DQ high impedance time from CK_t, CK_c	tHZ(DQ)	-	170	-	160	pS	39
Data Strobe Timing							
DQS_t, DQS_c differential READ Preamble (1 clock preamble)	tRPRE	0.9	Note 44	0.9	Note 44	nCK	39, 40
DQS_t, DQS_c differential READ Preamble (2 clock preamble)	tRPRE2	1.8	Note 44	1.8	Note 44	nCK	39, 41
DQS_t, DQS_c differential READ Postamble	tRPST	0.33	Note 45	0.33	Note 45	tCK	
DQS_t, DQS_c differential output high time	tQSH	0.4	-	0.4	-	tCK	21, 39
DQS_t, DQS_c differential output low time	tQSL	0.4	-	0.4	-	tCK	20, 39
DQS_t, DQS_c differential WRITE Preamble (1 clock preamble)	tWPRE	0.9	-	0.9	-	tCK	42
DQS_t, DQS_c differential WRITE Preamble (2 clock preamble)	tWPRE2	1.8	-	1.8	-	tCK	43
DQS_t, DQS_c differential WRITE Postamble	tWPST	0.33	-	0.33	-	tCK	
DQS_t and DQS_c low impedance time (Referenced from RL-1)	tLZ(DQS)	-310	170	-250	160	pS	39
DQS_t and DQS_c high impedance time (Referenced from RL+BL/2)	tHZ(DQS)	-	170	-	160	pS	39
DQS_t, DQS_c differential input low pulse width	tDQSL	0.46	0.54	0.46	0.54	tCK	
DQS_t, DQS_c differential input high pulse width	tDQSH	0.46	0.54	0.46	0.54	tCK	
DQS_t, DQS_c rising edge to CK_t, CK_c rising edge (1 clock preamble)	tDQSS	-0.27	0.27	-0.27	0.27	tCK	42
DQS_t, DQS_c rising edge to CK_t, CK_c rising edge (2 clock preamble)	tDQSS2	-0.50	0.50	-0.50	0.50	tCK	43
DQS_t, DQS_c falling edge setup time to CK_t, CK_c rising edge	tDSS	0.18	-	0.18	-	tCK	
DQS_t, DQS_c falling edge hold time from CK_t, CK_c rising edge	tDSH	0.18	-	0.18	-	tCK	
DQS_t, DQS_c rising edge output timing location from rising CK_t, CK_c with DLL On mode	tDQSCK (DLL On)	-170	170	-160	160	pS	37, 38, 39
DQS_t, DQS_c rising edge output variance window per DRAM	tDQSCKI (DLL On)	-	270	-	260	pS	37, 38, 39



Speed		DDR4-2666		DDR4-3200		Units	Notes
Parameter	Symbol	Min.	Max.	Min.	Max.		
Calibration Timing							
Power-up and RESET calibration time	tZQinit	1024	-	1024	-	nCK	
Normal operation Full calibration time	tZQoper	512	-	512	-	nCK	
Normal operation Short calibration time	tZQCS	128	-	128	-	nCK	
Reset/Self Refresh Timing							
Exit Reset from CKE HIGH to a valid command	tXPR	max(5nCK, tRFC(min) + 10nS)	-	max(5nCK, tRFC(min) + 10nS)	-	nCK	
Exit Self Refresh to commands not requiring a locked DLL	tXS	tRFC(min) + 10nS	-	tRFC(min) + 10nS	-	nCK	
SRX to commands not requiring a locked DLL in Self Refresh ABORT	tXS_ABORT(min)	tRFC4(min) + 10nS	-	tRFC4(min) + 10nS	-	nCK	
Exit Self Refresh to ZQCL, ZQCS and MRS (CL, CWL, WR, RTP and Gear-Down)	tXS_FAST(min)	tRFC4(min) + 10nS	-	tRFC4(min) + 10nS	-	nCK	
Exit Self Refresh to commands requiring a locked DLL	tXSDLL	tDLLK(min)	-	tDLLK(min)	-	nCK	
Minimum CKE low width for Self refresh entry to exit timing	tCKESR	tCKE(min) + 1nCK	-	tCKE(min) + 1nCK	-	nCK	
Minimum CKE low width for Self refresh entry to exit timing with CA Parity enabled	tCKESR_PAR	tCKE(min) + 1nCK + PL	-	tCKE(min) + 1nCK + PL	-	nCK	
Valid Clock Requirement after Self Refresh Entry (SRE) or Power-Down Entry (PDE)	tCKSRE	max(5nCK, 10nS)	-	max(5nCK, 10nS)	-	nCK	
Valid Clock Requirement after Self Refresh Entry (SRE) or Power-Down when CA Parity is enabled	tCKSRE_PAR	max(5nCK, 10nS) + PL	-	max(5nCK, 10nS) + PL	-	nCK	
Valid Clock Requirement before Self Refresh Exit (SRX) or Power-Down Exit (PDX) or Reset Exit	tCKSRX	max(5nCK, 10nS)	-	max(5nCK, 10nS)	-	nCK	
Power Down Timing							
Exit Power Down with DLL on to any valid command; Exit Precharge Power Down with DLL frozen to commands not requiring a locked DLL	tXP	max(4nCK, 6nS)	-	max(4nCK, 6nS)	-	nCK	
CKE minimum pulse width	tCKE	max(3nCK, 5nS)	-	max(3nCK, 5nS)	-	nCK	31, 32
Command pass disable delay	tCPDED	4	-	4	-	nCK	
Power Down Entry to Exit Timing	tPD	tCKE(min)	9*tREFI	tCKE(min)	9*tREFI	nCK	6
Timing of ACT command to Power Down entry	tACTPDEN	2	-	2	-	nCK	7
Timing of PRE or PREA command to Power Down entry	tPRPDEN	2	-	2	-	nCK	7
Timing of RD/RDA command to Power Down entry	tRDPDEN	RL + 4 + 1	-	RL + 4 + 1	-	nCK	
Timing of WR command to Power Down entry (BL8OTF, BL8MRS, BC4OTF)	tWRPDEN	WL + 4 + (tWR/tCK(avg))	-	WL + 4 + (tWR/tCK(avg))	-	nCK	4
Timing of WRA command to Power Down entry (BL8OTF, BL8MRS, BC4OTF)	tWRAPDEN	WL + 4 + WR + 1	-	WL + 4 + WR + 1	-	nCK	5
Timing of WR command to Power Down entry (BC4MRS)	tWRPBC4DEN	WL + 2 + (tWR/tCK(avg))	-	WL + 2 + (tWR/tCK(avg))	-	nCK	4



Speed		DDR4-2666		DDR4-3200		Units	Notes
Parameter	Symbol	Min.	Max.	Min.	Max.		
Timing of WRA command to Power Down entry (BC4MRS)	tWRAPBC4DEN	WL + 2 + WR + 1	-	WL + 2 + WR + 1	-	nCK	5
Timing of REF command to Power Down entry	tREFPDEN	2	-	2	-	nCK	7
Timing of MRS command to Power Down entry	tMRSPDEN	tMOD(min)	-	tMOD(min)	-	nCK	
PDA Timing							
Mode Register Set command cycle time in PDA mode	tMRD_PDA	max(16nCK, 10nS)	-	max(16nCK, 10nS)	-	nCK	
Mode Register Set command update delay in PDA mode	tMOD_PDA	tMOD		tMOD		nCK	
ODT Timing							
Asynchronous RTT turn-on delay (Power-Down with DLL frozen)	tAONAS	1.0	9.0	1.0	9.0	nS	
Asynchronous RTT turn-off delay (Power-Down with DLL frozen)	tAOFAS	1.0	9.0	1.0	9.0	nS	
RTT dynamic change skew	tADC	0.28	0.72	0.26	0.74	tCK(avg)	
Write Leveling Timing							
First DQS_t/DQS_c rising edge after write leveling mode is programmed	tWLMRD	40	-	40	-	nCK	12
DQS_t/DQS_c delay after write leveling mode is programmed	tWLDQSEN	25	-	25	-	nCK	12
Write leveling setup time from rising CK_t, CK_c crossing to rising DQS_t/DQS_c crossing	tWLS	0.13	-	0.13	-	tCK(avg)	
Write leveling hold time from rising DQS_t/DQS_c crossing to rising CK_t, CK_c crossing	tWLH	0.13	-	0.13	-	tCK(avg)	
Write leveling output delay	tWLO	0	9.5	0	9.5	nS	
Write leveling output error	tWLOE	0	2	0	2	nS	
CA Parity Timing							
Commands not guaranteed to be executed during this time	tPAR_UNKNOWN	-	PL	-	PL	nCK	
Delay from errant command to ALERT_n assertion	tPAR_ALERT_ON		PL + 6nS		PL + 6nS	nCK	
Pulse width of ALERT_n signal when asserted	tPAR_ALERT_PW	80	160	96	192	nCK	
Time from when Alert is asserted till controller must start providing DES commands in Persistent CA parity mode	tPAR_ALERT_RSP	-	71	-	85	nCK	
Parity Latency	PL	5		6		nCK	
CRC Error Reporting							
CRC error to ALERT_n latency	tCRC_ALERT	3	13	3	13	nS	
CRC ALERT_n pulse width	CRC_ALERT_PW	6	10	6	10	nCK	
Gear-Down timing							
Exit RESET from CKE HIGH to a valid MRS gear-down (T2/Reset)	tXPR_GEAR	tXPR	-	tXPR	-	nCK	
CKE High Assert to Gear-Down Enable time (T2/CKE)	tXS_GEAR	tXS	-	tXS	-	nCK	
MRS command to Sync pulse time (T3)	tSYNC_GEAR	tMOD + 4nCK	-	tMOD + 4nCK	-	nCK	27



Speed		DDR4-2666		DDR4-3200		Units	Notes
Parameter	Symbol	Min.	Max.	Min.	Max.		
Sync pulse to First valid command (T4)	tCMD_GEAR	tMOD	-	tMOD	-	nCK	27
Gear-down setup time	tGEAR_setup	2	-	2	-	nCK	
Gear-down hold time	tGEAR_hold	2	-	2	-	nCK	
tREFI							
tRFC1 (min)	4Gb	260	-	260	-	nS	34
tRFC2 (min)	4Gb	160	-	160	-	nS	34
tRFC4 (min)	4Gb	110	-	110	-	nS	34



Notes to Table 120 and Table 121

1. Start of internal write transaction is defined as follows:
 For BL8 (Fixed by MRS and on-the-fly): Rising clock edge 4 clock cycles after WL.
 For BC4 (On-the-fly): Rising clock edge 4 clock cycles after WL.
 For BC4 (Fixed by MRS): Rising clock edge 2 clock cycles after WL.
2. A separate timing parameter will cover the delay from write to read when CRC and DM are simultaneously enabled.
3. Commands requiring a locked DLL are: READ (and RAP) and synchronous ODT commands.
4. tWR is defined in ns, for calculation of tWRPDEN it is necessary to round up tWR/tCK following rounding algorithm defined in Section 17.5.
5. WR in clock cycles as programmed in MR0.
6. tREFI depends on TOPER.
7. CKE is allowed to be registered low while operations such as row activation, precharge, auto precharge or refresh are in progress, but power-down IDD spec will not be applied until finishing those operations.
8. For these parameters, the DDR4 SDRAM device supports $t_n\text{PARAM}[n\text{CK}] = \text{RU}\{t\text{PARAM}[n\text{S}]/t\text{CK}(\text{avg})[n\text{S}]\}$, which is in clock cycles assuming all input clock jitter specifications are satisfied.
9. When CRC and DM are both enabled, tWR_CRC_DM is used in place of tWR.
10. When CRC and DM are both enabled tWTR_S_CRC_DM is used in place of tWTR_S.
11. When CRC and DM are both enabled tWTR_L_CRC_DM is used in place of tWTR_L.
12. The max values are system dependent.
13. DQ to DQS total timing per group where the total includes the sum of deterministic and random timing terms for a specified BER.
14. The deterministic component of the total timing.
15. DQ to DQ static offset relative to strobe per group.
16. This parameter will be characterized and guaranteed by design.
17. When the device is operated with the input clock jitter, this parameter needs to be derated by the actual tjit(per)_total of the input clock. (Output deratings are relative to the SDRAM input clock).
18. DRAM DBI mode is off.
19. DRAM DBI mode is enabled. Applicable to x8 and x16 DRAM only.
20. tQSL describes the instantaneous differential output low pulse width on DQS_t - DQS_c, as measured from on falling edge to the next consecutive rising edge.
21. tQSH describes the instantaneous differential output high pulse width on DQS_t - DQS_c, as measured from on falling edge to the next consecutive rising edge.
22. There is no maximum cycle time limit besides the need to satisfy the refresh interval tREFI.
23. tCH(abs) is the absolute instantaneous clock high pulse width, as measured from one rising edge to the following falling edge.
24. tCL(abs) is the absolute instantaneous clock low pulse width, as measured from one falling edge to the following rising edge.
25. Total jitter includes the sum of deterministic and random jitter terms for a specified BER.
26. The deterministic jitter component out of the total jitter. This parameter is characterized and guaranteed by design.
27. This parameter has to be even number of clocks
28. When CRC and DM are both enabled, tWR_CRC_DM is used in place of tWR.
29. When CRC and DM are both enabled tWTR_S_CRC_DM is used in place of tWTR_S.
30. When CRC and DM are both enabled tWTR_L_CRC_DM is used in place of tWTR_L.
31. After CKE is registered LOW, CKE signal level shall be maintained below VILDC for tCKE specification (Low pulse width).
32. After CKE is registered HIGH, CKE signal level shall be maintained above VIHDC for tCKE specification (HIGH pulse width).
33. Defined between end of MPR read burst and MRS which reloads MPR or disables MPR function.
34. Parameters apply from tCK(avg)min to tCK(avg)max at all standard JEDEC clock period values as stated in the Speed Bin Tables.
35. This parameter must keep consistency with Speed-Bin Tables shown in section 14.
36. DDR4-1600 AC timing apply if DRAM operates at lower than 1600 MT/s data rate. $UI = t\text{CK}(\text{avg})_{\text{min}}/2$
37. Applied when DRAM is in DLL ON mode.
38. Assume no jitter on input clock signals to the DRAM.
39. Value is only valid for RONNOM = 34 ohms.
40. 1tCK toggle mode with setting MR4:A11 to 0.
41. 2tCK toggle mode with setting MR4:A11 to 1, which is valid for DDR4-2400/2666/3200 speed grade.
42. 1tCK mode with setting MR4:A12 to 0.
43. 2tCK mode with setting MR4:A12 to 1, which is valid for DDR4-2400/2666/3200 speed grade.
44. The maximum read preamble is bounded by tLZ(DQS)min on the left side and tDQSCK(max) on the right side. See Figure 65 on page 97 "Clock to Data Strobe Relationship". Boundary of DQS Low-Z occur one cycle earlier in 2tCK toggle mode which is illustrated in section 9.22.2 "Read Preamble".
45. DQ falling signal middle-point of transferring from High to Low to first rising edge of DQS diff-signal cross-point.
46. Last falling edge of DQS diff-signal cross-point to DQ rising signal middle-point of transferring from Low to High.
47. VrefDQ value must be set to either its midpoint or Vcent_DQ(midpoint) in order to capture DQL0 low level for entering PDA mode.
48. The maximum read postamble is bound by tDQSCK(min) plus tQSH(min) on the left side and tHZ(DQS)max on the right side. See Figure 65 on page 97.
49. Reference level of DQ output signal is specified with a midpoint as a widest part of output signal eye which should be approximately $0.7 * VDDQ$ as a center level of the static single-ended output peak-to-peak swing with a driver impedance of 34 ohms and an effective test load of 50 ohms to $V_{TT} = VDDQ$.
50. For MR7 commands, the minimum delay to a subsequent non-MRS command is 5nCK.
51. tDALmin is required to refer to the rounding algorithm specified in section 17.5.



17.5 Rounding Algorithms

Software algorithms for calculation of timing parameters are subject to rounding errors from many sources. For example, a system may use a memory clock with a nominal frequency of 933.33... MHz, or a clock period of 1.0714... nS. Similarly, a system with a memory clock frequency of 1066.66... MHz yields mathematically a clock period of 0.9375... nS. In most cases, it is impossible to express all digits after the decimal point exactly, and rounding must be done because the DDR4 SDRAM specification establishes a minimum granularity for timing parameters of 1 pS.

Rules for rounding must be defined to allow optimization of device performance without violating device parameters. These algorithms rely on results that are within correction factors on device testing and specification to avoid losing performance due to rounding errors.

These rules are:

- Clock periods such as tCKAVGmin are defined to 1 pS of accuracy; for example, 0.9375... nS is defined as 937 pS and 1.0714... ns is defined as 1071 pS.
- Using real math, parameters like tAAmin, tRCDmin, etc. which are programmed in systems in numbers of clocks (nCK) but expressed in units of time (in nS) are divided by the clock period (in nS) yielding a unitless ratio, a correction factor of 2.5% is subtracted, then the result is set to the next higher integer number of clocks:

$$\text{nCK} = \text{ceiling} [(\text{parameter_in_ns} / \text{application_tCK_in_ns}) - 0.025]$$

- Alternatively, programmers may prefer to use integer math instead of real math by expressing timing in ps, scaling the desired parameter value by 1000, dividing by the application clock period, adding an inverse correction factor of 97.4%, dividing the result by 1000, then truncating down to the next lower integer value:

$$\text{nCK} = \text{truncate} [\{ (\text{parameter_in_pS} \times 1000) / (\text{application_tCK_in_pS}) + 974 \} / 1000]$$

- Either algorithm yields identical results. In case of conflict between results, the preferred algorithm is the integer math algorithm.
- This algorithm applies to all timing parameters documented in a Serial Presence Detect (SPD) when converting from ns to nCK. Other timing parameters may use a simpler algorithm,
 $\text{nCK} = \text{ceiling} (\text{parameter_in_nS} \div \text{application_tCK_in_nS})$.



Example 1, using REAL math to convert t_{AAmin} from nS to nCK:

```
// This algorithm subtracts 2.5% correction factor and rounds up to next integer value
real MTB, FTB, TaaMin, Correction, ClockPeriod, TempNck;
int TaaInNck;

TaaMin = 15.0; // Calculate tAAmin in ns (FTB is negative offset)
Correction = 0.025; // 2.5%, per rounding algorithm
ClockPeriod = ApplicationTck; // Frequency (clock period) is application dependent
TempNck = TaaMin / ClockPeriod; // Initial calculation of nCK
TempNck = TempNck - Correction; // Subtract correction factor from nCK
TaaInNck = (int)ceiling(TempNck); // Ceiling to next higher integer value//
```

DDR4-2666(20-20-20) Device Operating at Standard Application Data Rates (Full & Downbinned)						
Timing Parameter: $t_{AAmin} = 15.0nS$						
Application Speed Grade	Device t_{AA}	Application t_{CK}	Device $t_{AA} \div$ Application t_{CK}	2.5% Correction	$t_{AA} / t_{CK} -$ Correction	Ceiling Result
	nS	nS	ratio (real)	(real)	ratio (real)	nCK (integer)
2666	15.00	0.750	20.0	0.025	19.975	20
2400	15.00	0.833	18.0072	0.025	17.9822	18
2133	15.00	0.937	16.00854	0.025	15.9835	16
1866	15.00	1.071	14.0056	0.025	13.9806	14
1600	15.00	1.250	12.0	0.025	11.975	12

Notes:

- Roundup values for bins 2400, 2133, and 1866 would have lost one clock of performance without the application of the rounding algorithm. For example, a DDR4-2666(20-20-20) device running at DDR4-2400 data rates would have been required to set t_{AA} to 19 clocks without correction, but with correction t_{AA} may be safely programmed to 18 clocks.
- The more detailed SPD rounding algorithm examples are also described in Annex L-4.1.2, in JESD21C.

Example 2, using INT math to convert t_{AAmin} from nS to nCK:

```
// This algorithm uses adds 97.4% of a clock and truncates down to the next lower integer value
int MTB, FTB, TaaMin, ClockPeriod, TempNck, TaaInNck;

TaaMin = 15000; // Calculate tAAmin in nS (FTB is negative offset)
ClockPeriod = ApplicationTckInPs; // Clock period is application specific
TempNck = (TaaMin * 1000) / ApplicationTckInPs; // Preliminary nCK calculation, scaled by 1000
TempNck = TempNck + 974; // Apply inverse of 2.5% correction factor
TaaInNck = (int)(TempNck / 1000); // Truncate to next lower integer
```

DDR4-2666(20-20-20) Device Operating at Standard Application Data Rates (Full & Downbinned)					
Timing Parameter: $t_{AAmin} = 15.0nS$ (15000pS)					
Application Speed Grade	Device t_{AA}	Application t_{CK}	(Device $t_{AA} * 1000$) Application t_{CK}	Add Inverse Correction	Truncate Corrected nCK / 1000
	pS	pS	Scaled nCK	Scaled nCK	nCK (integer)
2666	15000	750	20000	220974	20
2400	15000	833	18007	18981	18
2133	15000	937	16008	16982	16
1866	15000	1071	14005	14979	14
1600	15000	1250	12000	12974	12

Note:

- The more detailed SPD rounding algorithm examples are also described in Annex L-4.1.2, in JESD21C.



17.6 The DQ input receiver compliance mask for voltage and timing

The DQ input receiver compliance mask for voltage and timing is shown in the figure below. The receiver mask (Rx Mask) defines area the input signal must not encroach in order for the DRAM input receiver to be expected to be able to successfully capture a valid input signal with BER of 1e-16; any input signal encroaching within the Rx Mask is subject to being invalid data. The Rx Mask is the receiver property for each DQ input pin and it is not the valid data-eye.

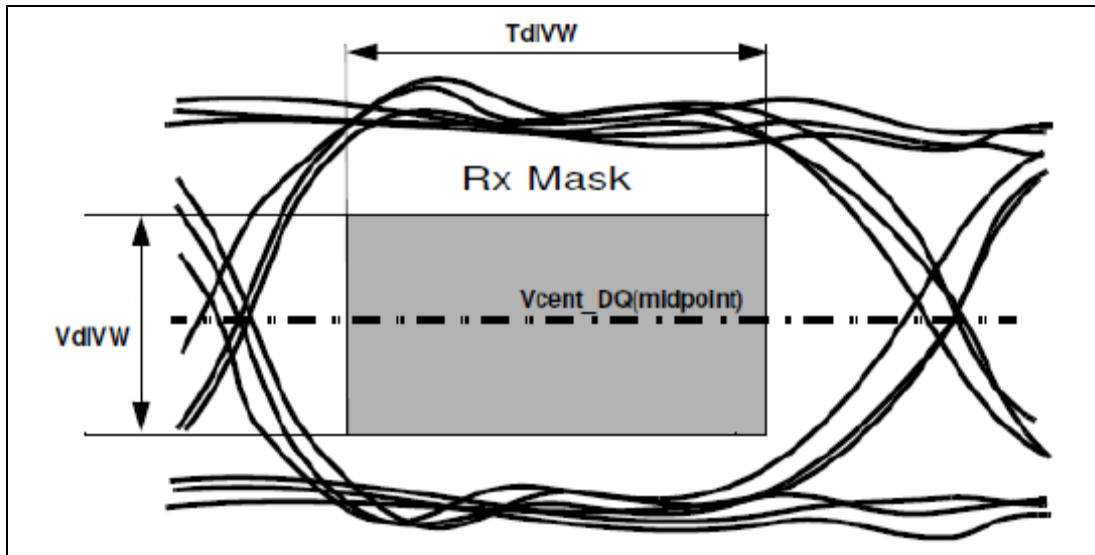

Figure 198 – DQ Receiver (Rx) compliance mask

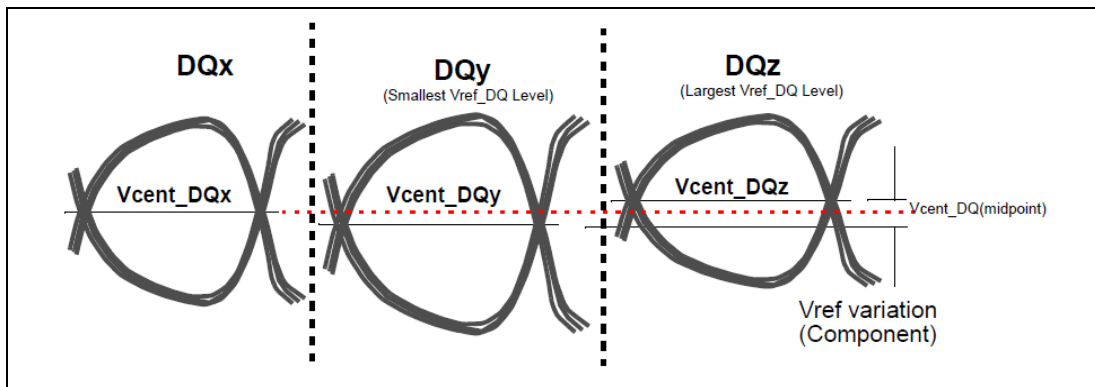
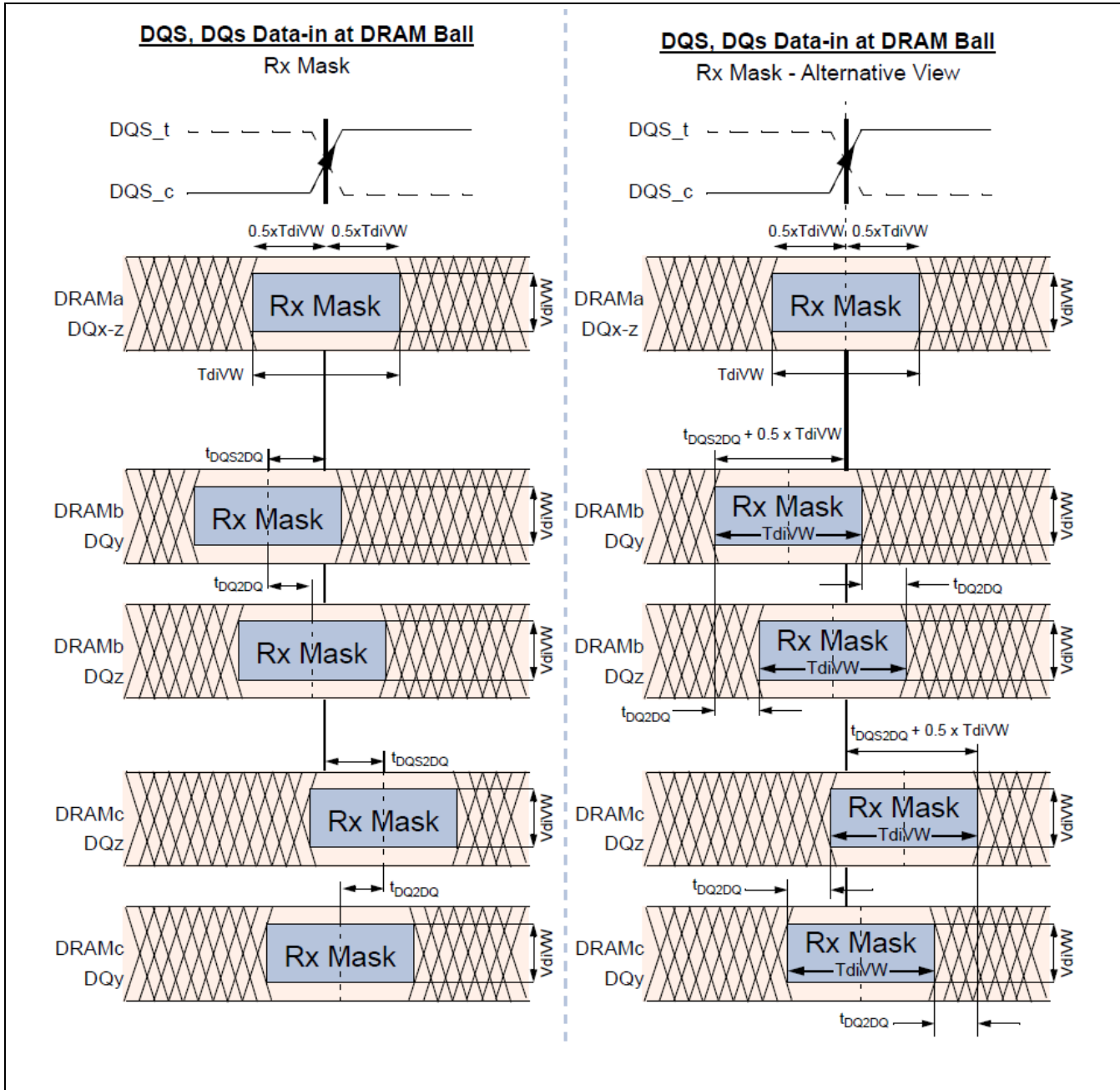

Figure 199 – Vcent_DQ Variation to Vcent_DQ(midpoint)

The Vref_DQ voltage is an internal reference voltage level that shall be set to the properly trained setting, which is generally Vcent_DQ(midpoint), in order to have valid Rx Mask values.

Vcent_DQ(midpoint) is defined as the midpoint between the largest Vref_DQ voltage level and the smallest Vref_DQ voltage level across all DQ pins for a given DDR4 DRAM component. Each DQ pin Vref level is defined by the center, i.e. widest opening, of the cumulative data input eye as depicted in Figure 199. This clarifies that any DDR4 DRAM component level variation must be accounted for within the DDR4 DRAM Rx mask. The component level Vref will be set by the system to account for Ron and ODT settings.



Notes: DQx represents an optimally centered mask. DQy represents earliest valid mask. DQz represents latest valid mask. **Notes:** DRAMa represents a DRAM without any DQS/DQ skews. DRAMB represents a DRAM with early skews (negative t_{DQS2DQ}). DRAMc represents a DRAM with delayed skews (positive t_{DQS2DQ}).

Note: Figures show skew allowed between DRAM to DRAM and DQ to DQ for a DRAM. Signals assume data centered aligned at DRAM Latch. T_{diPW} is not shown; composite data-eyes shown would violate T_{diPW} . $V_{CENT} DQ(\text{midpoint})$ is not shown but is assumed to be midpoint of V_{diVW}

Figure 200 – DQS to DQ and DQ to DQ Timings at DRAM Balls

All of the timing terms in Figure 200 are measured at the V_{diVW} voltage levels centered around $V_{cent_DQ}(\text{midpoint})$ and are referenced to the DQS_t/DQS_c center aligned to the DQ per pin.



The rising edge slew rates are defined by srr1 and srr2. The slew rate measurement points for a rising edge are shown in Figure 201 below: A low to high transition t_{r1} is measured from $0.5 \cdot V_{dIVW}(\max)$ below $V_{cent_DQ}(\text{midpoint})$ to the last transition through $0.5 \cdot V_{dIVW}(\max)$ above $V_{cent_DQ}(\text{midpoint})$ while t_{r2} is measured from the last transition through $0.5 \cdot V_{dIVW}(\max)$ above $V_{cent_DQ}(\text{midpoint})$ to the first transition through the $0.5 \cdot V_{IHL_AC}(\min)$ above $V_{cent_DQ}(\text{midpoint})$.

Rising edge slew rate equations:

$$srr1 = V_{dIVW}(\max) / t_{r1}$$

$$srr2 = (V_{IHL_AC}(\min) - V_{dIVW}(\max)) / (2 \cdot t_{r2})$$

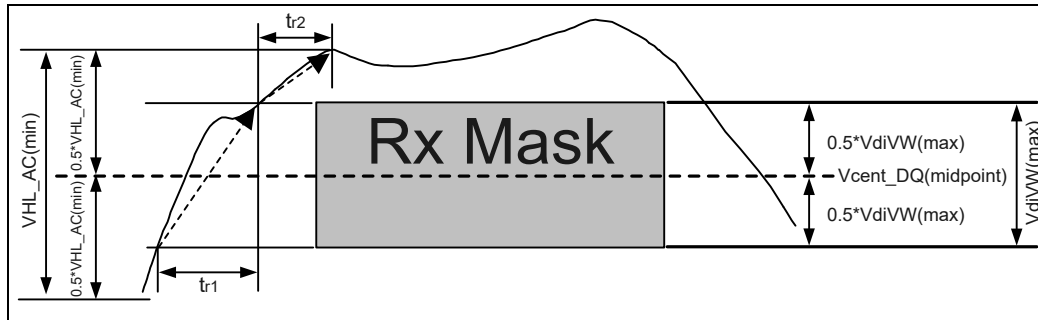

Figure 201 – Slew Rate Conditions for Rising Transition

The falling edge slew rates are defined by srf1 and srf2. The slew rate measurement points for a falling edge are shown in Figure 202 below: A high to low transition t_{f1} is measured from $0.5 \cdot V_{dIVW}(\max)$ above $V_{cent_DQ}(\text{midpoint})$ to the last transition through $0.5 \cdot V_{dIVW}(\max)$ below $V_{cent_DQ}(\text{midpoint})$ while t_{f2} is measured from the last transition through $0.5 \cdot V_{dIVW}(\max)$ below $V_{cent_DQ}(\text{midpoint})$ to the first transition through the $0.5 \cdot V_{IHL_AC}(\min)$ below $V_{cent_DQ}(\text{pin mid})$.

Falling edge slew rate equations:

$$srf1 = V_{dIVW}(\max) / t_{f1}$$

$$srf2 = (V_{IHL_AC}(\min) - V_{dIVW}(\max)) / (2 \cdot t_{f2})$$

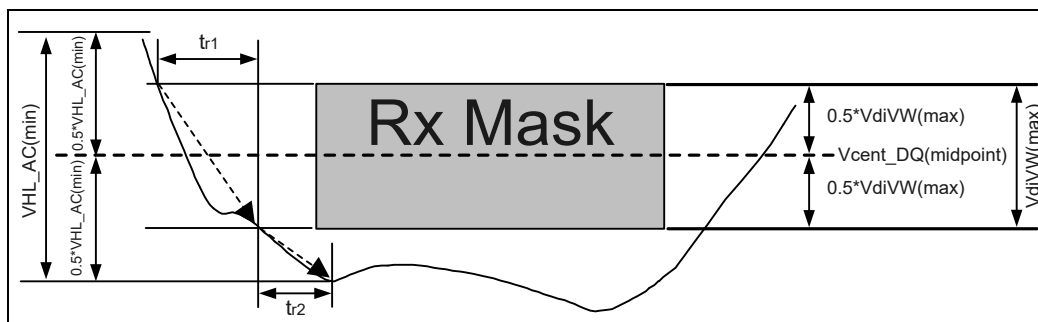

Figure 202 – Slew Rate Conditions for Falling Transition



Table 122 – DRAM DQs In Receive Mode; * UI=tCK(avg)min/2

Symbol	Parameter	1600,1866,2133		2400		2666		3200		Unit	Notes
		min	max	min	max	min	max	min	max		
VdIVW	Rx Mask voltage - pk-pk	-	136	-	130	-	120	-	110	mV	1, 2, 10
TdIVW	Rx timing window	-	0.2	-	0.2	-	0.22	-	0.23	UI*	1, 2, 10
VIHL_AC	DQ AC input swing pk-pk	186	-	160	-	150	-	140	-	mV	3, 4, 10
TdiPW	DQ input pulse width	0.58	-	0.58	-	0.58	-	0.58	-	UI*	5, 10
tdQS2DQ	Rx Mask DQS to DQ offset	-0.17	0.17	-0.17	0.17	-0.19	0.19	-0.22	0.22	UI*	6, 10
tdQ2DQ	Rx Mask DQ to DQ offset	-	0.1	-	0.1	-	0.105	-	0.125	UI*	7
srr1, srf1	Input Slew Rate over VdIVW if tCK ≥ 0.937nS	1	9	1	9	1	9	1	9	V/nS	8, 10
	Input Slew Rate over VdIVW if 0.937ns > tCK ≥ 0.625nS	-	-	1.25	9	1.25	9	1.25	9	V/nS	8, 10
srr2	Rising Input Slew Rate over 1/2 VIHL_AC	0.2*srr1	9	0.2*srr1	9	0.2*srr1	9	0.2*srr1	9	V/nS	9, 10
srf2	Falling Input Slew Rate over 1/2 VIHL_AC	0.2*srf1	9	0.2*srf1	9	0.2*srf1	9	0.2*srf1	9	V/nS	9, 10

Notes:

1. Data Rx mask voltage and timing total input valid window where VdIVW is centered around Vcent_DQ(midpoint) after VREFDQ training is completed. The data Rx mask is applied per bit and should include voltage and temperature drift terms. The input buffer design specification is to achieve at least a BER = e-16 when the RxMask is not violated.
2. Defined over the DQ internal VREF range 1.
3. Overshoot and Undershoot Specifications see Table 81 on page 183.
4. DQ input pulse signal swing into the receiver must meet or exceed VIHL AC(min). VIHL_AC(min) is to be achieved on an UI basis when a rising and falling edge occur in the same UI, i.e. a valid TdiPW.
5. DQ minimum input pulse width defined at the Vcent_DQ(midpoint).
6. DQS to DQ offset is skew between DQS and DQs within a word at the DDR4 SDRAM balls over process, voltage, and temperature.
7. DQ to DQ offset is skew between DQs within a word at the DDR4 SDRAM balls for a given component over process, voltage, and temperature.
8. Input slew rate over VdIVW Mask centered at Vcent_DQ(midpoint). Slowest DQ slew rate to fastest DQ slew rate per transition edge must be within 1.7 V/nS of each other.
9. Input slew rate between VdIVW Mask edge and VIHL_AC(min) points.
10. All Rx Mask specifications must be satisfied for each UI. For example, if the minimum input pulse width is violated when satisfying TdIVW(min), VdIVW(max), and minimum slew rate limits, then either TdIVW(min) or minimum slew rates would have to be increased to the point where the minimum input pulse width would no longer be violated.



17.7 Command, Control, and Address Setup, Hold, and Derating

The total tIS (setup time) and tIH (hold time) required is calculated to account for slew rate variation by adding the data sheet tIS (base) values, the VIL(AC)/VIH(AC) points, and tIH (base) values, the VIL(DC)/VIH(DC) points; to the ΔtIS and ΔtIH derating values, respectively. The base values are derived with single-end signals at 1V/ns and differential clock at 2V/nS. Example: tIS (total setup time) = tIS (base) + ΔtIS . For a valid transition, the input signal has to remain above/below VIH(AC)/VIL(AC) for the time defined by tVAC.

Although the total setup time for slow slew rates might be negative (for example, a valid input signal will not have reached VIH(AC)/VIL(AC) at the time of the rising clock transition), a valid input signal is still required to complete the transition and to reach VIH(AC)/VIL(AC). For slew rates that fall between the values listed in derating tables, the derating values may be obtained by linear interpolation.

Setup (tIS) nominal slew rate for a rising signal is defined as the slew rate between the last crossing of VIL(DC)max and the first crossing of VIH(AC)min that does not ring back below VIH(DC)min. Setup (tIS) nominal slew rate for a falling signal is defined as the slew rate between the last crossing of VIH(DC)min and the first crossing of VIL(AC)max that does not ring back above VIL(DC)max. Hold (tIH) nominal slew rate for a rising signal is defined as the slew rate between the last crossing of VIL(DC)max and the first crossing of VIH(AC)min that does not ring back below VIH(DC)min. Hold (tIH) nominal slew rate for a falling signal is defined as the slew rate between the last crossing of VIH(DC)min and the first crossing of VIL(AC)min that does not ring back above VIL(DC)max.

Table 123 – Command, Address, Control Setup and Hold Values

DDR4	1600	1866	2133	2400	2666	3200	Unit	Reference
tIS(base, AC100)	115	100	80	62	-	-	pS	VIH/L(ac)
tIH(base, DC75)	140	125	105	87	-	-	pS	VIH/L(dc)
tIS(base, AC 90)	-	-	-	-	55	40	pS	VIH/L(ac)
tIH(base, DC65)	-	-	-	-	80	65	pS	VIH/L(dc)
tIS/tIH @ VREF	215	200	180	162	145	130	pS	

Notes:

1. Base ac/dc referenced for 1V/nS slew rate and 2 V/nS clock slew rate.
2. Values listed are referenced only; applicable limits are defined elsewhere.

Table 124 – Command, Address, Control Input Voltage Values

DDR4	1600	1866	2133	2400	2666	3200	Unit	Reference
VIH.CA(AC)min	100	100	100	100	90	90	mV	VIH/L(ac)
VIH.CA(DC)min	75	75	75	75	65	65	mV	VIH/L(dc)
VIL.CA(DC)max	-75	-75	-75	-75	-65	-65	mV	VIH/L(ac)
VIL.CA(AC)max	-100	-100	-100	-100	-90	-90	mV	VIH/L(dc)

Notes:

1. Command, Address, Control input levels relative to VREFCA.
2. Values listed are referenced only; applicable limits are defined elsewhere.



Table 125 – Derating values DDR4-1600/1866/2133/2400 tIS/tIH - ac/dc based

ΔtIS, ΔIH derating in [pS] AC/DC based*1																
CMD/ADDR Slew Rate V/nS	CK_t, CK_c Differential Slew Rate															
	10.0 V/nS		8.0 V/nS		6.0 V/nS		4.0 V/nS		3.0 V/nS		2.0 V/nS		1.5 V/nS		1.0 V/nS	
	ΔtIS	ΔtIH	ΔtIS	ΔtIH	ΔtIS	ΔtIH	ΔtIS	ΔtIH	ΔtIS	ΔtIH	ΔtIS	ΔtIH	ΔtIS	ΔtIH	ΔtIS	ΔtIH
7.0	76	54	76	55	77	56	79	58	82	60	86	64	94	73	111	89
6.0	73	53	74	53	75	54	77	56	79	58	83	63	92	71	108	88
5.0	70	50	71	51	72	52	74	54	76	56	80	60	88	68	105	85
4.0	65	46	66	47	67	48	69	50	71	52	75	56	83	65	100	81
3.0	57	40	57	41	58	42	60	44	63	46	67	50	75	58	92	75
2.0	40	28	41	28	42	29	44	31	46	33	50	38	58	46	75	63
1.5	23	15	24	16	25	17	27	19	29	21	33	25	42	33	58	50
1.0	-10	-10	-9	-9	-8	-8	-6	-6	-4	-4	0	0	8	8	25	25
0.9	-17	-14	-16	-14	-15	-13	-13	-10	-11	-8	-7	-4	1	4	18	21
0.8	-26	-19	-25	-19	-24	-18	-22	-16	-20	-14	-16	-9	-7	-1	9	16
0.7	-37	-26	-36	-25	-35	-24	-33	-22	-31	-20	-27	-16	-18	-8	-2	9
0.6	-52	-35	-51	-34	-50	-33	-48	-31	-46	-29	-42	-25	-33	-17	-17	-0
0.5	-73	-48	-72	-47	-71	-46	-69	-44	-67	-42	-63	-38	-54	-29	-38	-13
0.4	-104	-66	-103	-66	-102	-65	-100	-63	-98	-60	-94	-56	-85	-48	-69	-31

Note:

1. VIH/L(ac) = ±100 mV, VIH/L(dc) = ±75 mV; relative to VREFCA.

Table 126 – Derating values DDR4-2666/3200 tIS/tIH - ac/dc based

ΔtIS, ΔIH derating in [pS] AC/DC based*1																
CMD/ADDR Slew Rate V/nS	CK_t, CK_c Differential Slew Rate															
	10.0 V/nS		8.0 V/nS		6.0 V/nS		4.0 V/nS		3.0 V/nS		2.0 V/nS		1.5 V/nS		1.0 V/nS	
	ΔtIS	ΔtIH	ΔtIS	ΔtIH	ΔtIS	ΔtIH	ΔtIS	ΔtIH	ΔtIS	ΔtIH	ΔtIS	ΔtIH	ΔtIS	ΔtIH	ΔtIS	ΔtIH
7.0	68	47	69	47	70	48	72	50	73	52	77	56	85	63	100	78
6.0	66	45	67	46	68	47	69	49	71	50	75	54	83	62	98	77
5.0	63	43	64	44	65	45	66	46	68	48	72	52	80	60	95	75
4.0	59	40	59	40	60	41	62	43	64	45	68	49	75	56	90	71
3.0	51	34	52	35	53	36	54	38	56	40	60	43	68	51	83	66
2.0	36	24	37	24	38	25	39	27	41	29	45	33	53	40	68	55
1.5	21	13	22	13	23	14	24	16	26	18	30	22	38	29	53	44
1.0	-9	-9	-8	-8	-8	-8	-6	-6	-4	-4	0	0	8	8	23	23
0.9	-15	-13	-15	-12	-14	-11	-12	-9	-10	-7	-6	-4	1	4	16	19
0.8	-23	-17	-23	-17	-22	-16	-20	-14	-18	-12	-14	-8	-7	-1	8	14
0.7	-34	-23	-33	-22	-32	-21	-30	-20	-28	-18	-25	-14	-17	-6	-2	9
0.6	-47	-31	-47	-30	-46	-29	-44	-27	-42	-25	-38	-22	-31	-14	-16	1
0.5	-67	-42	-66	-41	-65	-40	-63	-38	-61	-36	-58	-33	-50	-25	-35	-10
0.4	-95	-58	-95	-57	-94	-56	-92	-54	-90	-53	-86	-49	-79	-41	-64	-26

Note:

1. VIH/L(ac) = ±90 mV, VIH/L(dc) = ±65 mV; relative to VREFCA.



17.8 Function Matrix

Table 127 – W664GG6RB functions supported (V: Supported, Blank: Not supported)

Functions	W664GG6RB
Write Leveling	V
Temperature Controlled Refresh	V
Low Power Auto Self Refresh	V
Fine Granularity Refresh	V
Multi Purpose Register	V
Data Mask	V
Data Bus Inversion	V
TDQS	
ZQ calibration	V
DQ VREF Training	V
Per DRAM Addressability	V
Mode Register Readout	V
CAL	V
WRITE CRC	V
CA Parity	V
Control Gear-Down Mode	V
Programmable Preamble	V
Connectivity Test Mode	V
Additive Latency	V
Hard post package repair mode	V
Soft post package repair mode	V



Table 128 – W664GG6RB functions supported by speed (V: Supported, Blank: Not supported)

Functions	DLL Off mode	DLL On mode (Data Rate: Mbps)					
	equal or slower than 250Mbps	1600	1866	2133	2400	2666	3200
Write Leveling	V	V	V	V	V	V	V
Temperature Controlled Refresh	V	V	V	V	V	V	V
Low Power Auto Self Refresh	V	V	V	V	V	V	V
Fine Granularity Refresh	V	V	V	V	V	V	V
Multi Purpose Register	V	V	V	V	V	V	V
Data Mask	V	V	V	V	V	V	V
Data Bus Inversion	V	V	V	V	V	V	V
TDQS							
ZQ calibration	V	V	V	V	V	V	V
DQ VREF Training	V	V	V	V	V	V	V
Per DRAM Addressability		V	V	V	V	V	V
Mode Register Readout	V	V	V	V	V	V	V
CAL		V	V	V	V	V	V
WRITE CRC		V	V	V	V	V	V
CA Parity		V	V	V	V	V	V
Control Gear-Down Mode						V	V
Programmable Preamble (= 2tCK)					V	V	V
Connectivity Test Mode	V	V	V	V	V	V	V
Additive Latency	V	V	V	V	V	V	V
Hard post package repair mode		V	V	V	V	V	V
Soft post package repair mode		V	V	V	V	V	V



18. Package Specification

Package Outline VFBGA96 Ball (7.5x13 mm², ball pitch: 0.8mm) – (Window BGA Type)

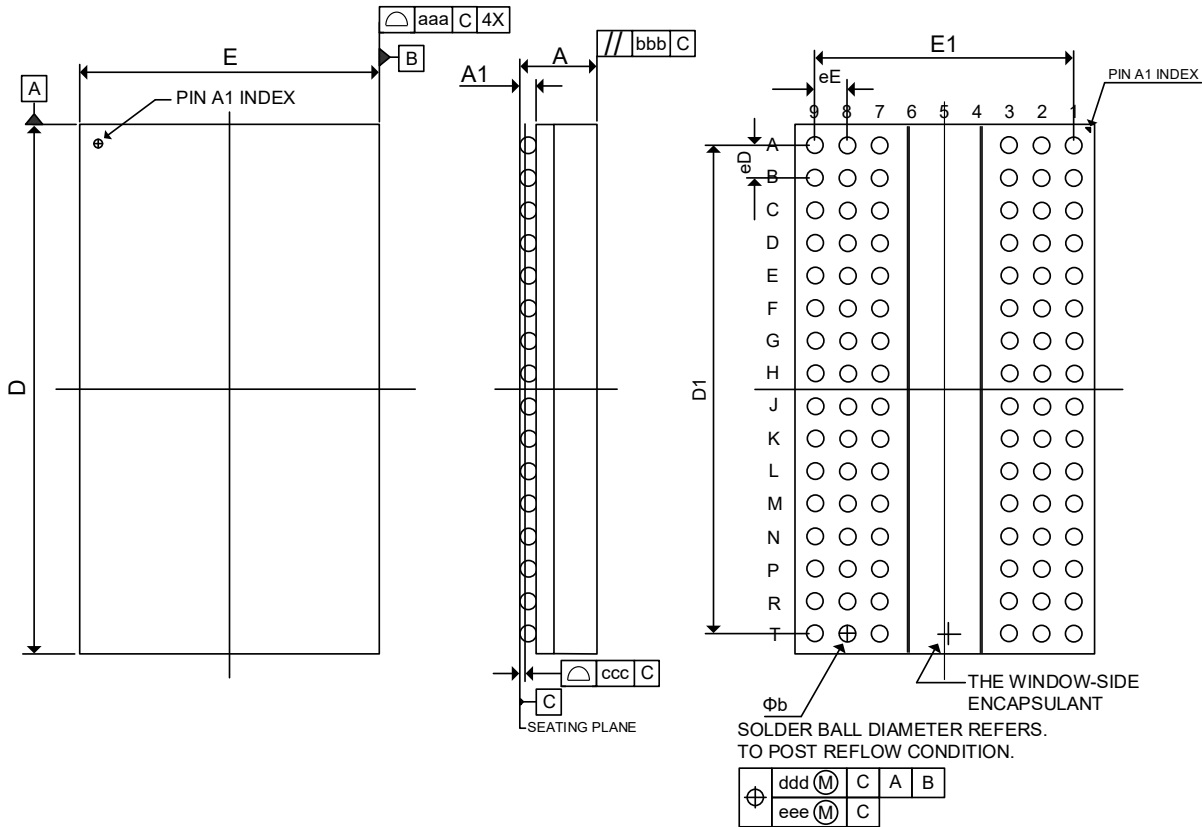

SYMBOL	DIMENSION (MM)			DIMENSION (INCH)		
	MIN.	NOM.	MAX.	MIN.	NOM.	MAX.
A	0.80	0.90	1.00	0.031	0.035	0.039
A1	0.25	---	0.40	0.010	---	0.016
b	0.40	---	0.50	0.016	---	0.020
D	12.90	13.00	13.10	0.508	0.512	0.516
E	7.40	7.50	7.60	0.291	0.295	0.299
D1	12.00 BSC.			0.472 BSC.		
E1	6.40 BSC.			0.252 BSC.		
eE	0.80 BSC.			0.032 BSC.		
eD	0.80 BSC.			0.032 BSC.		
aaa	---	---	0.15	---	---	0.006
bbb	---	---	0.20	---	---	0.008
ccc	---	---	0.10	---	---	0.004
ddd	---	---	0.15	---	---	0.006
eee	---	---	0.08	---	---	0.003

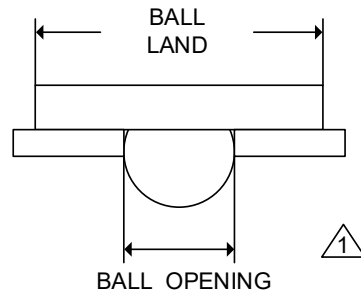

Note:
 1. Ball land: 0.5mm, Ball opening: 0.4mm,
 PCB Ball land suggested ≤ 0.4mm



19. Revision History

VERSION	DATE	PAGE	DESCRIPTION
A01	Jul. 26, 2024	All	Initial formal datasheet
A02	Sep. 16, 2024	7, 204	Correct last CWL = 16,20 setting of Read non DBI and Read DBI max. value in DDR4-3200 speed bin table typos from < 0.75 nS to < 0.682 nS
		222, 223	Update of IDD6A and IPP6A parameters spec value
A03	Dec. 26, 2024	157, 158	Remove original section 9.32 CLK to Read DQS timing parameters (Include original Table 59, Figure 158, 159 and 160)
		180	Remove redundant TBD spec of Table 77
		191, 192, 222, 238, 244	Remove redundant with TBD wording
		224	Remove orginial Silicon pad I/O Capacitance spec Table

*Please note that all data and specifications are subject to change without notice.
All the trademarks of products and companies mentioned in this datasheet belong to their respective owners.*

*Publication Release Date: Dec. 26, 2024
Revision: A03*

Looking for pricing, stock, or lifecycle information?

Click below to explore more details on WIN SOURCE:

- ⊖ [View W664GG6RB-06](#) on WIN SOURCE
- ⊖ [Winbond Electronics](#) Information

Optimize Your Supply Chain with WIN SOURCE Solutions

- ✓ Global Sourcing Solution
- ✓ Obsolete Management
- ✓ Cost Control Management
- ✓ Shortage Management
- ✓ Alternative Solution
- ✓ Excess Inventory Management