



THE DATASHEET OF
180-026-203L011



DESCRIPTION: HIGH DENSITY FEMALE - SOLDER CUP

DIMENSIONS

No. OF PINS		A	B	C	D	E	F	G	H
		inch	1.213	0.984	0.643	0.311	0.090	0.756	0.496
15	mm	30.80	24.99	16.34	7.90	2.29	19.20	12.60	10.90
	inch	1.543	1.312	0.966	0.311	0.090	1.091	0.496	0.429
26	mm	39.15	33.32	24.53	7.90	2.29	27.70	12.60	10.90
	inch	2.087	1.852	1.512	0.311	0.090	1.618	0.496	0.429
44	mm	53.00	47.04	38.40	7.90	2.29	41.10	12.60	10.90
	inch	2.728	2.500	2.156	0.311	0.095	2.256	0.496	0.429
62	mm	69.30	63.50	54.76	7.90	2.41	57.30	12.60	10.90
	inch	2.638	2.406	2.057	0.429	0.095	2.169	0.606	0.526
78	mm	67.00	61.10	52.26	10.90	2.41	55.10	15.40	13.35

4 ROWS

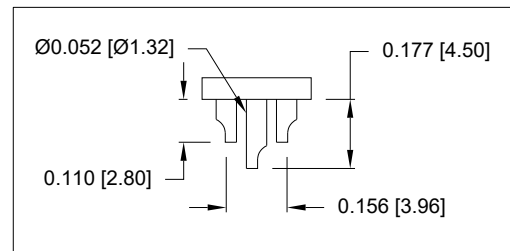
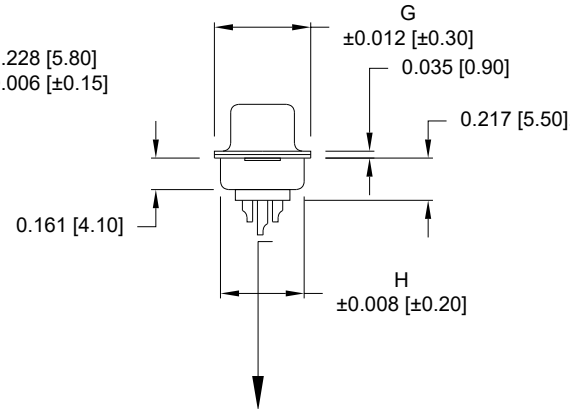
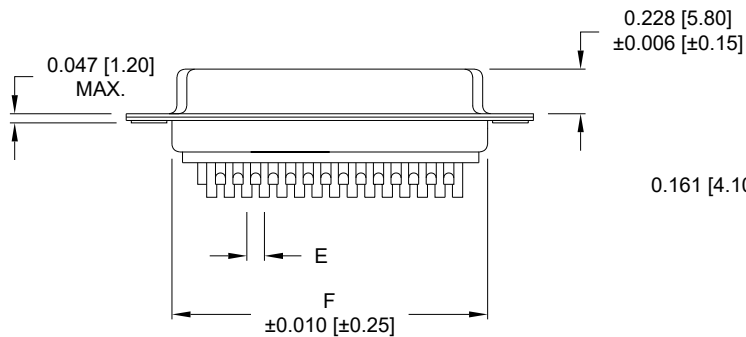
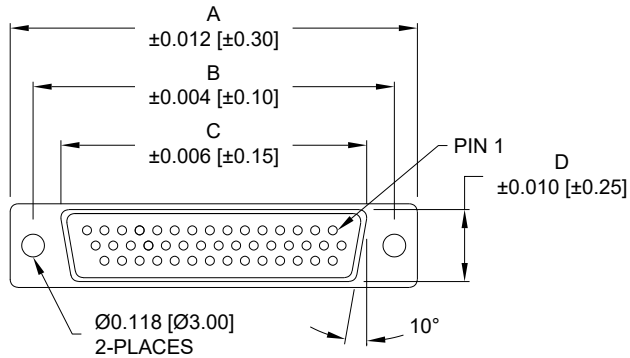

NOTE: WILL ACCEPT UP TO 24 AWG WIRE

SPECIFICATIONS:

MATERIALS:

INSULATOR: PBT 30% GF, UL94 V-0 (PROCESS TEMP 230°C)
 CONTACTS: GOLD PLATED BRASS OVER NICKEL
 SHELL: NICKEL OR TIN PLATED STEEL

ELECTRICAL:

RATED CURRENT: 3A
 VOLTAGE: 500VAC FOR 1 MINUTE
 INSULATION RESISTANCE: 1000 MOhms MIN.
 CONTACT RESISTANCE: 15 mOhms MAX.

ENVIRONMENT:

OPERATING TEMPERATURE: -50°C TO +100°C

180-YYY-20YLYY1

SERIES _____
 POSITIONS _____
 015
 026
 044
 062
 078
 GENDER _____
 2 = FEMALE
 TERMINATION _____
 0 = SOLDER CUP
 SHELL PLATING _____
 2 = TIN (DISCONTINUED)
 3 = NICKEL
 HARDWARE OPTIONS _____
 00 = NO HARDWARE
 01 = .098" CLINCH NUT (SOLDER SIDE)
 02 = .236" CLINCH NUT (SOLDER SIDE)
 03 = .236" CLINCH NUT (MATING SIDE)
 PLATING OPTIONS _____
 1 = GOLD FLASH
 2 = 30u" GOLD MATING AREA; GF ON TAILS

RoHS COMPLIANT

UNITS = inch [mm]

DO NOT SCALE FROM DRAWING



THESE DRAWINGS AND SPECIFICATIONS ARE THE PROPERTY OF NorComp AND SHALL NOT BE REPRODUCED, COPIED OR USED AS THE BASIS FOR THE MANUFACTURE OR SALE OF APPARATUS WITHOUT WRITTEN PERMISSION.

DRAWN: P. JENKINS

DATE: 08/12/1998

NorComp

SCALE: NTS SHEET 1 OF 2 REV 14

DWG NO. 180-YYY-20YLYY1

ALL CLINCH-NUTS ARE 4-40 INTERNAL THREADS

01 0.098" (SOLDER SIDE)

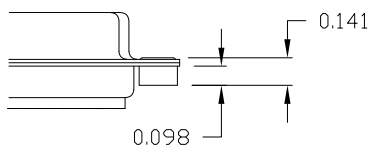

02 0.236" (SOLDER SIDE)

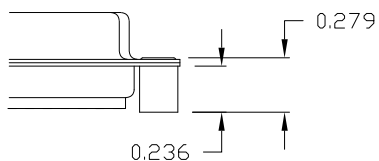

03 0.236" (MATING SIDE)

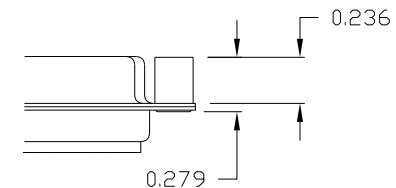

RoHS COMPLIANT

UNITS = inch

DO NOT SCALE FROM DRAWING



THESE DRAWINGS AND SPECIFICATIONS ARE THE PROPERTY OF NorComp AND SHALL NOT BE REPRODUCED, COPIED OR USED AS THE BASIS FOR THE MANUFACTURE OR SALE OF APPARATUS WITHOUT WRITTEN PERMISSION.

DRAWN:
P. JENKINS

DATE:
08/12/1998

NorComp

SCALE:
NTS

SHEET OF
2 2

REV
14

DWG NO.

180-YYY-20YLYY1

Looking for pricing, stock, or lifecycle information?

Click below to explore more details on WIN SOURCE:

 [View 180-026-203L011 on WIN SOURCE](#)

 [NorComp Inc. Information](#)

Optimize Your Supply Chain with WIN SOURCE Solutions

-  Global Sourcing Solution
-  Obsolete Management
-  Cost Control Management
-  Shortage Management
-  Alternative Solution
-  Excess Inventory Management