



**THE DATASHEET OF**  
**180-026-203L021**



DESCRIPTION: HIGH DENSITY FEMALE - SOLDER CUP

DIMENSIONS

No. OF PINS		A	B	C	D	E	F	G	H
		inch	1.213	0.984	0.643	0.311	0.090	0.756	0.496
15	mm	30.80	24.99	16.34	7.90	2.29	19.20	12.60	10.90
	inch	1.543	1.312	0.966	0.311	0.090	1.091	0.496	0.429
26	mm	39.15	33.32	24.53	7.90	2.29	27.70	12.60	10.90
	inch	2.087	1.852	1.512	0.311	0.090	1.618	0.496	0.429
44	mm	53.00	47.04	38.40	7.90	2.29	41.10	12.60	10.90
	inch	2.728	2.500	2.156	0.311	0.095	2.256	0.496	0.429
62	mm	69.30	63.50	54.76	7.90	2.41	57.30	12.60	10.90
	inch	2.638	2.406	2.057	0.429	0.095	2.169	0.606	0.526
78	mm	67.00	61.10	52.26	10.90	2.41	55.10	15.40	13.35

4 ROWS

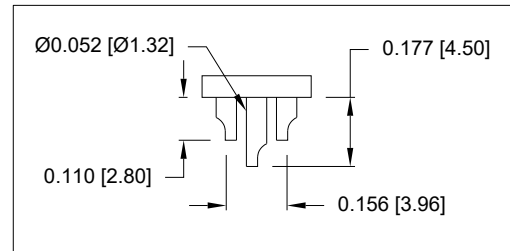
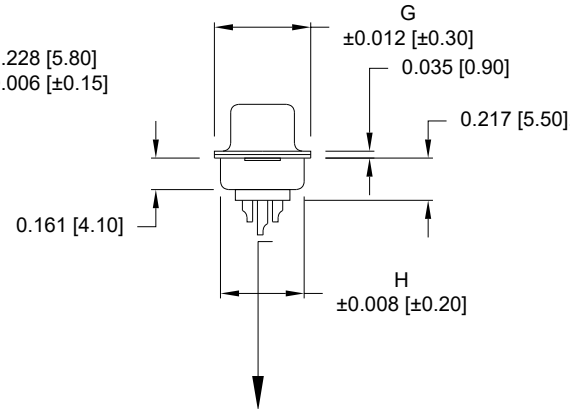
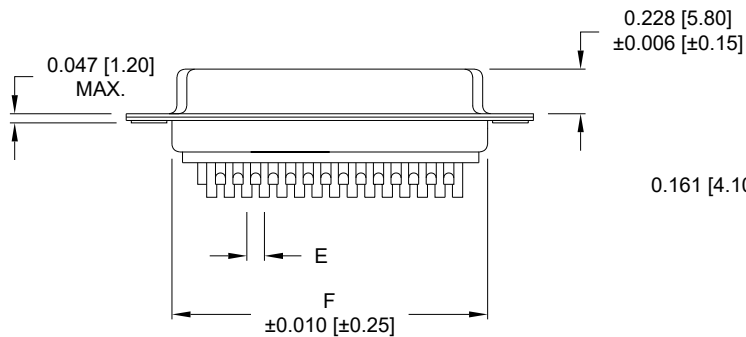
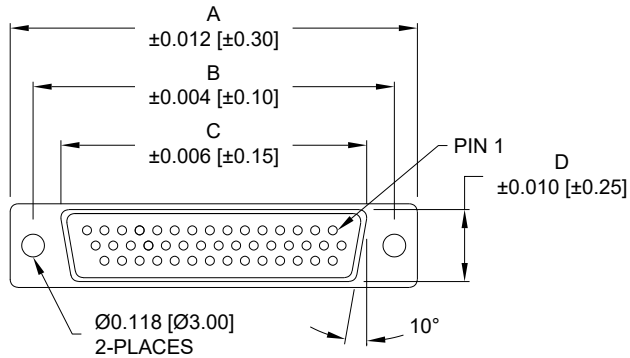

NOTE: WILL ACCEPT UP TO 24 AWG WIRE

SPECIFICATIONS:

**MATERIALS:**

INSULATOR:

PBT 30% GF, UL94 V-0  
(PROCESS TEMP 230°C)

CONTACTS:

GOLD PLATED BRASS OVER NICKEL

SHELL:

NICKEL OR TIN PLATED STEEL

**ELECTRICAL:**

RATED CURRENT:

3A

VOLTAGE:

500VAC FOR 1 MINUTE

INSULATION RESISTANCE:

1000 MOhms MIN.

CONTACT RESISTANCE:

15 mOhms MAX.

**ENVIRONMENT:**

OPERATING TEMPERATURE: -50°C TO +100°C

**180-YYY-20YLYY1**

SERIES	180-YYY-20YLYY1
POSITIONS	180-YYY-20YLYY1
015	180-YYY-20YLYY1
026	180-YYY-20YLYY1
044	180-YYY-20YLYY1
062	180-YYY-20YLYY1
078	180-YYY-20YLYY1
GENDER	2 = FEMALE
TERMINATION	0 = SOLDER CUP
SHELL PLATING	2 = TIN (DISCONTINUED) 3 = NICKEL
HARDWARE OPTIONS	00 = NO HARDWARE 01 = .098" CLINCH NUT (SOLDER SIDE) 02 = .236" CLINCH NUT (SOLDER SIDE) 03 = .236" CLINCH NUT (MATING SIDE)
PLATING OPTIONS	1 = GOLD FLASH 2 = 30u" GOLD MATING AREA; GF ON TAILS

RoHS COMPLIANT

UNITS = inch [mm]

DO NOT SCALE FROM DRAWING



THESE DRAWINGS AND SPECIFICATIONS ARE THE PROPERTY OF NorComp AND SHALL NOT BE REPRODUCED, COPIED OR USED AS THE BASIS FOR THE MANUFACTURE OR SALE OF APPARATUS WITHOUT WRITTEN PERMISSION.

DRAWN:

P. JENKINS

DATE:

08/12/1998

NorComp

SCALE:  
NTS

SHEET 1 OF 2

REV 14

DWG NO.

180-YYY-20YLYY1

**ALL CLINCH-NUTS ARE 4-40 INTERNAL THREADS**

01 ..... 0.098" (SOLDER SIDE)

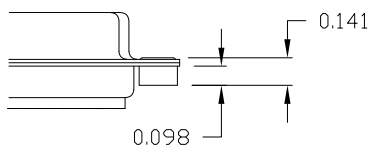

02 ..... 0.236" (SOLDER SIDE)

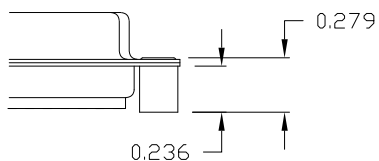

03 ..... 0.236" (MATING SIDE)

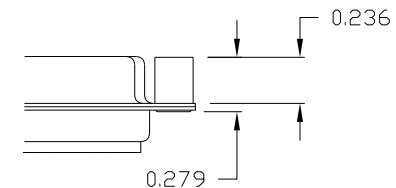

**RoHS COMPLIANT**

UNITS = inch

**DO NOT SCALE FROM DRAWING**



THESE DRAWINGS AND SPECIFICATIONS ARE THE PROPERTY OF NorComp AND SHALL NOT BE REPRODUCED, COPIED OR USED AS THE BASIS FOR THE MANUFACTURE OR SALE OF APPARATUS WITHOUT WRITTEN PERMISSION.

DRAWN:  
**P. JENKINS**

DATE:  
**08/12/1998**

**NorComp**

SCALE:  
NTS

SHEET OF  
2 2

REV  
14

DWG NO.

**180-YYY-20YLYY1**

## Looking for pricing, stock, or lifecycle information?

Click below to explore more details on WIN SOURCE:

 [View 180-026-203L021 on WIN SOURCE](#)

 [NorComp Inc. Information](#)

## Optimize Your Supply Chain with WIN SOURCE Solutions

-  Global Sourcing Solution
-  Obsolete Management
-  Cost Control Management
-  Shortage Management
-  Alternative Solution
-  Excess Inventory Management