



**THE DATASHEET OF
DF1EC-10P-2.5DSA(36)**



2.5mm Pitch Connectors for Full Lock and Discrete Wire Connection

DF1E Series

UL, C-UL Listed

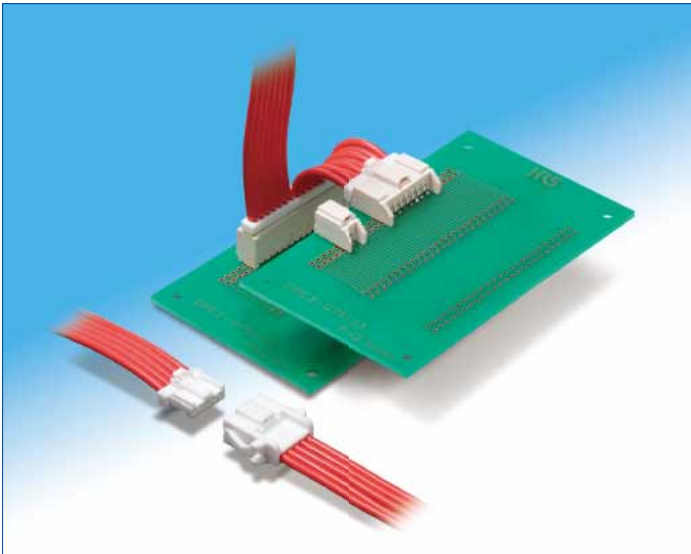

Full lock function added

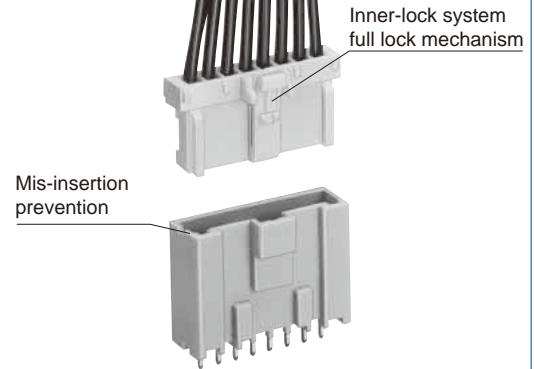

Fig.1

■ Features

1. Full Lock Function Added

The inner lock system adopts a full lock mechanism. This mechanism prevents disengagement to occur due to an unexpected external shock. (Fig.1)

2. Increase in Crimping Contact Fixation Force and Semi-insertion Prevention

The double lock is activated for the use method to give a stress to the cable, to increase crimping contact fixation force, and to prevent the semi-insertion of the crimping contact. (Fig.2)

3. Mold Lance Adopted

Since the contact lance may be deformed involving in the contact after the crimping process, the mold lance has been adopted.

4. Mis-insertion Prevention

Equipped with the mechanism to completely prevent reverse insertion and insertion between dissimilar contacts. (Fig.1)

5. Means to Prevent Solder Crack

The glass enforcement resin is adopted for the pin header to prevent a solder crack to occur due to heat compression.

6. Production Facility Cost Reduction

The female crimping contact uses the DF1B series crimping contact, which has been conventionally marketed. Investment for new facilities isn't needed. However, if the retainer is installed in the cable with 22 AWG or more wire, use the DF1E crimping contact. The female crimping contact for in-line is used together with the DF1B applicator. Therefore, no investment is needed for new facilities.

Double lock engaged

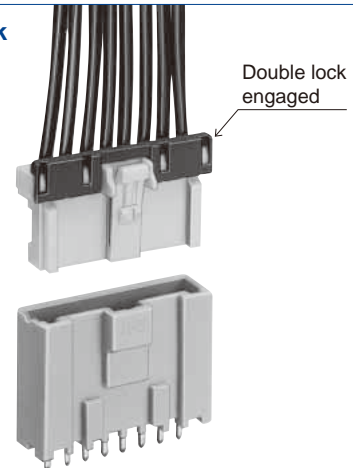

Fig.2

7. Various Applications

With the same series, various applications can be used for the board solder dip type and in-line.

8. Listed by UL, C-UL

Products Specifications

Rating	Current rating (Note 1) 20 to 24 AWG : 3A/pin 26 AWG : 2A/pin 28 AWG : 1A/pin 30 AWG : 0.5A/pin	Operating Temperature : -35 to +85°C (Note 2)	Storage Temperature Range : -10 to +60°C (Note 4)
	Voltage rating 250V AC/DC	Operating Moisture Range : 40 to 80% (Note 3)	Storage Moisture Range : 40 to 70% (Notes 4)

UL, C-UL Rating		
Rating	Current rating	20 to 22 AWG : 3A/pin 24 to 28 AWG : 1A/pin 30 AWG : 0.5A/pin
	Voltage rating	29.9V AC/DC

■UL/C-UL File No. and Recognition No.

UL : E52653

C-UL : E52653

Item	Specification	Condition
1. Contact Resistance	30mΩ max.	Measured at 20mV max. and 1mA
2. Insulation Resistance	1000MΩ min.	500V DC
3. Withstanding voltage	No flashover or insulation breakdown.	650V AC/1 minute
4. Durability (Mating/un-mating)	30mΩ max	Tin plated : 30 cycles, Gold plated : 50 cycles
5. Vibration	No electrical discontinuity of 1μs or more	Frequency : 10 to 55 Hz, single amplitude of 0.75 mm, 2 hours in each of the 3 directions.
6. Shock	No electrical discontinuity of 1μs or more	Acceleration of 490 m/s ² , 11 ms duration, sine half-wave waveform, 3 cycles in each of the 3 axis
7. Humidity (Steady state)	30mΩ max	96 hours at temperature of 40±2°C and humidity of 90% to 95%
8. Temperature Cycle	30mΩ max.	(-55°C : 30 minutes-> 5 to 35°C : 5 minutes-> 85°C : 30 minutes-> 5 to 35°C : 5 minutes) 5 cycles
9. Resistance to Soldering heat	No deformation of components affecting performance.	Flow : 260°C for 10 seconds
		Manual soldering : 300°C for 3 seconds

Note 1 : Current rating of header is 3A.

Note 2 : Includes temperature rise caused by current flow.

Note 3 : Use without condensation on parts.

Note 4 : Applied for the product unused and packaged.

Note 5 : Information contained in this catalog represents general requirements for this Series.

Contact us for the drawings and specifications for a specific part number shown.

Materials / Finish

Product	Part	Material	Finish	Remarks	RoHS2
Socket	Insulator	Polyamide	White	UL94V-0	Yes
	Header	Polyamide	Beige	UL94V-0	
Header	Contact	Brass	Tin plated or Gold plated	————	
	In-line Plug	Polyamide	White	UL94V-0	
Retainer	Insulator	Polyamide	Black	UL94V-0	
Crimping contact	Contact	Phosphor copper	Tin plated or Gold plated	————	

◆ Application Pattern

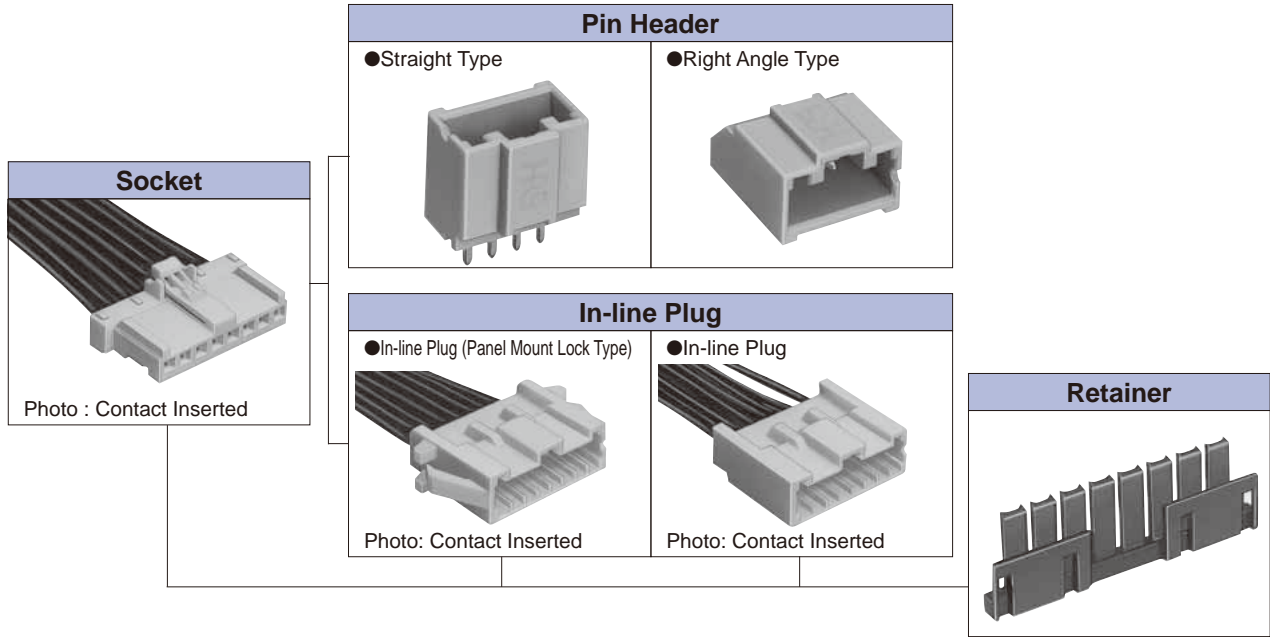

◆ Mated Dimensions

● Standard Header

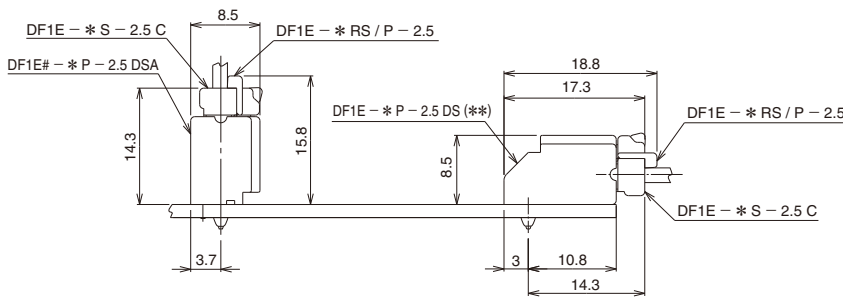

● Panel Mounting Lock In-line Plug

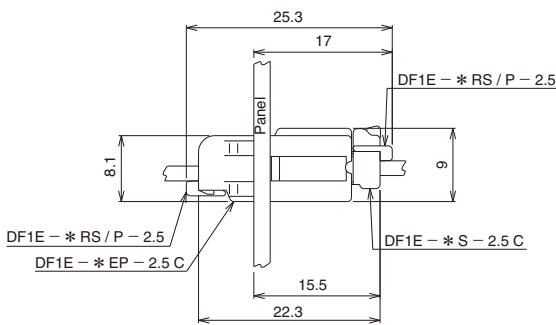

● In-line Plug

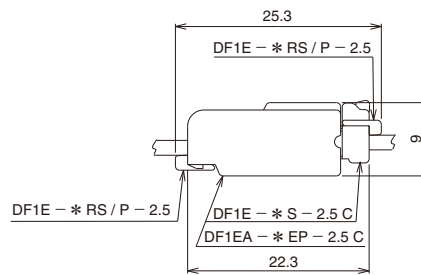

Right Angle Pin Header

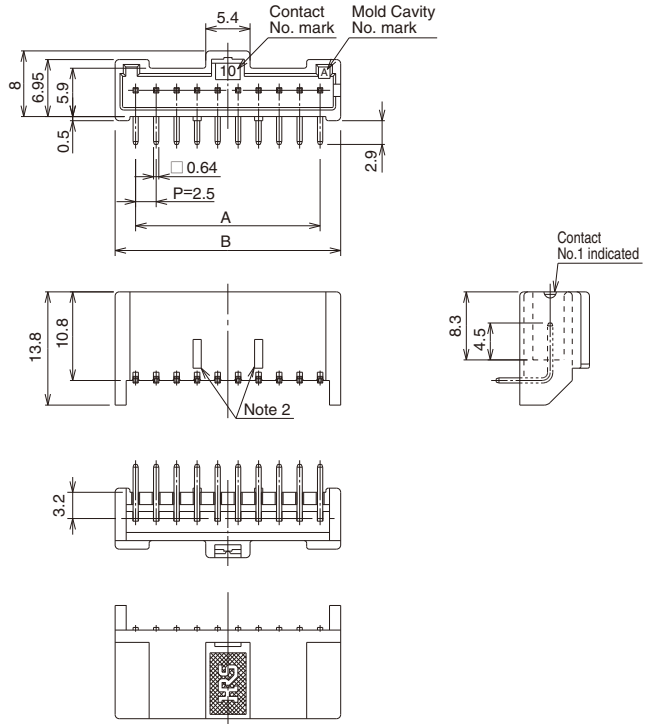
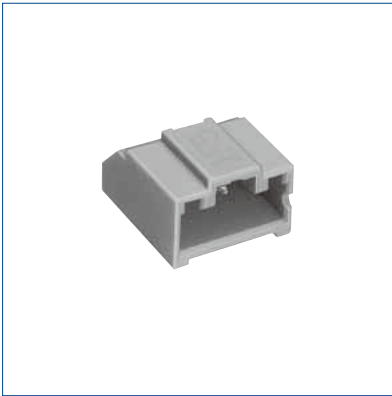

Unit : mm

Part No.	HRS No.	No. of Contacts	A	B
DF1E- 2P-2.5DS(**)	541-0985-0 **	2	2.5	7.5
DF1E- 3P-2.5DS(**)	541-0986-3 **	3	5.0	10.0
DF1E- 4P-2.5DS(**)	541-0987-6 **	4	7.5	12.5
DF1E- 5P-2.5DS(**)	541-0988-9 **	5	10.0	15.0
DF1E- 6P-2.5DS(**)	541-0989-1 **	6	12.5	17.5
DF1E- 7P-2.5DS(**)	541-0990-0 **	7	15.0	20.0
DF1E- 8P-2.5DS(**)	541-0991-3 **	8	17.5	22.5
DF1E- 9P-2.5DS(**)	541-0992-6 **	9	20.0	25.0
DF1E-10P-2.5DS(**)	541-0993-9 **	10	22.5	27.5
DF1E-11P-2.5DS(**)	541-0994-1 **	11	25.0	30.0
DF1E-12P-2.5DS(**)	541-0995-4 **	12	27.5	32.5
DF1E-14P-2.5DS(**)	541-0997-0 **	14	32.5	37.5
DF1E-15P-2.5DS(**)	541-0998-2 **	15	35.0	40.0

[Specific No.] -* *, (* *)
 (36) : Gold plated
 (35) : Tin plated

Note 1 : A packaging quantity is delivered by the bag unit (100 pcs.). If needed, please order the products per bag. However, the quantity for delivery will be changed according to the Specific No.

Note 2 : The 2 to 4 contacts differ in two convex portions from those in above figures. The 2 and 3 contacts are not contained, but the 4 contact connector is contained in the center at one point.

Note 3 : Styles of 2 to 4 contact connectors partially differ from those in above figures.

PCB mounting pattern (Board Thickness $t = 1.6 \pm 0.1$)

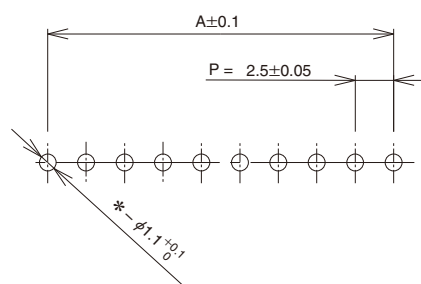

■ Straight Pin Header

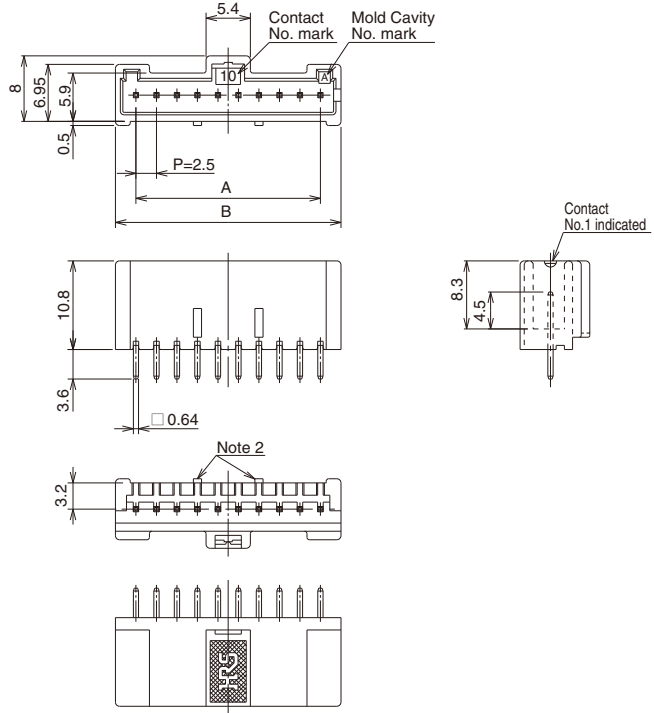
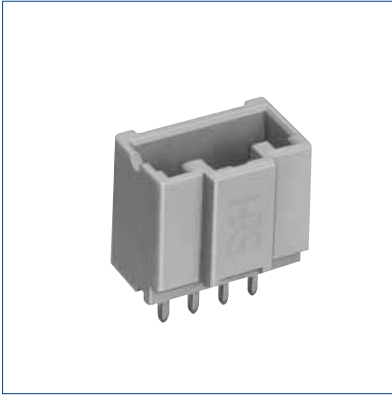

Unit : mm

Part No.	HRS No.	No. of Contacts	A	B
DF1EC- 2P-2.5DSA(**)	541-0867-4 **	2	2.5	7.5
DF1EC- 3P-2.5DSA(**)	541-0868-7 **	3	5.0	10.0
DF1EC- 4P-2.5DSA(**)	541-0869-0 **	4	7.5	12.5
DF1EC- 5P-2.5DSA(**)	541-0870-9 **	5	10.0	15.0
DF1EC- 6P-2.5DSA(**)	541-0871-1 **	6	12.5	17.5
DF1EC- 7P-2.5DSA(**)	541-0872-4 **	7	15.0	20.0
DF1EC- 8P-2.5DSA(**)	541-0873-7 **	8	17.5	22.5
DF1EC- 9P-2.5DSA(**)	541-0874-0 **	9	20.0	25.0
DF1EC-10P-2.5DSA(**)	541-0875-2 **	10	22.5	27.5
DF1EC-11P-2.5DSA(**)	541-0876-5 **	11	25.0	30.0
DF1EC-12P-2.5DSA(**)	541-0877-8 **	12	27.5	32.5
DF1EC-14P-2.5DSA(**)	541-0879-3 **	14	32.5	37.5
DF1EC-15P-2.5DSA(**)	541-0880-2 **	15	35.0	40.0

[Specific No.] -* *, (* *)
 (36) : Gold plated
 (35) : Tin plated

Note 1 : A packaging quantity is delivered by the bag unit (100 pcs.). If needed, please order the products per bag. However, the quantity for delivery will be changed according to the Specific No.

Note 2 : The 2 to 4 contacts differ in two convex portions from those in above figures. The 2 and 3 contacts are not contained, but the 2 and 3 contacts are not contained, and 4 contact is in the center at one point.

Note 3 : Styles of 2 to 4 contacts partially differ from those in above figures.

● PCB mounting pattern (Board Thickness $t = 1.6 \pm 0.1$)

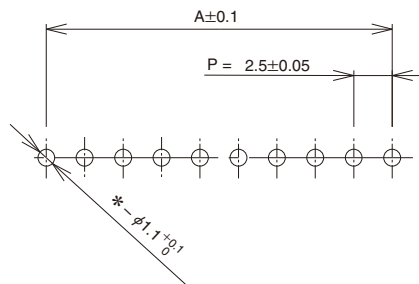

In-line Plug (Panel Mount Lock Type)

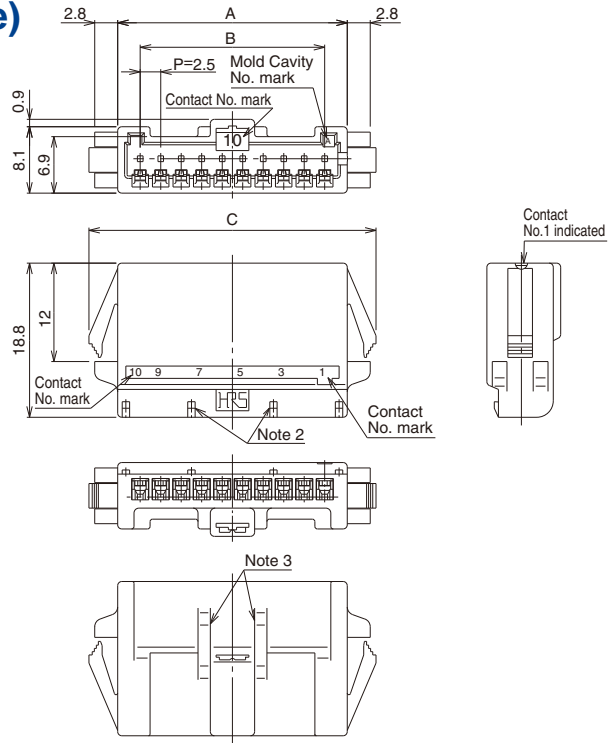
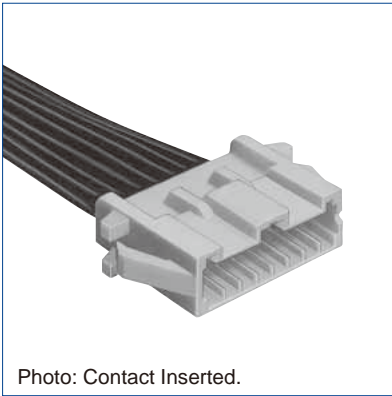

Unit : mm

Part No.	HRS No.	No. of Contacts	A	B	C	D	E
DF1E- 2EP-2.5C	541-0943-0	2	8.0	2.5	15.0	8.4	11.9
DF1E- 3EP-2.5C	541-0944-3	3	10.5	5.0	17.5	10.9	14.4
DF1E- 4EP-2.5C	541-0945-6	4	13.0	7.5	20.0	13.4	16.9
DF1E- 5EP-2.5C	541-0946-9	5	15.5	10.0	22.5	15.9	19.4
DF1E- 6EP-2.5C	541-0947-1	6	18.0	12.5	25.0	18.4	21.9
DF1E- 8EP-2.5C	541-0949-7	8	23.0	17.5	30.0	23.4	26.9
DF1E-10EP-2.5C	541-0951-9	10	28.0	22.5	35.0	28.4	31.9

Note 1 : A packaging quantity is delivered by the bag unit (100 pcs.). If needed, please order the products per bag. However, the quantity for delivery will be changed according to the Specific No.

Note 2 : In regard to 2 to 5 contacts, the retainer fixed convex portions are located at both ends.

Note 3 : In regard to 2 to 7 contacts, 2 convex portions are different from those in the above figures.

Note 4 : Use the no radius side at the panel edge in the looking area.

Note 5 : Panel fixation is loosened. (May be enlarged according to the panel board thickness.)

Note 6 : Styles of 2 to 4 contact partially differ from those in the above figures.

* Refer to page 11 for the retainer.

Panel Cutout

Unit : mm

Panel Thickness	X
1.7 to 2.0	1.5
1.3 to 1.6	1.0
0.9 to 1.2	0.5
0.7 to 0.8	0.0

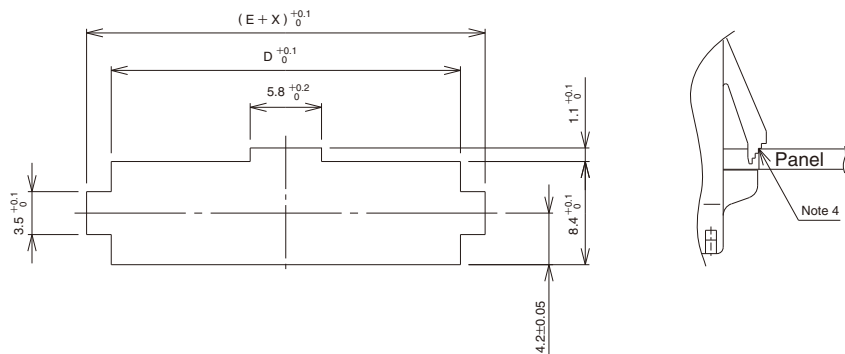

In-line Plug

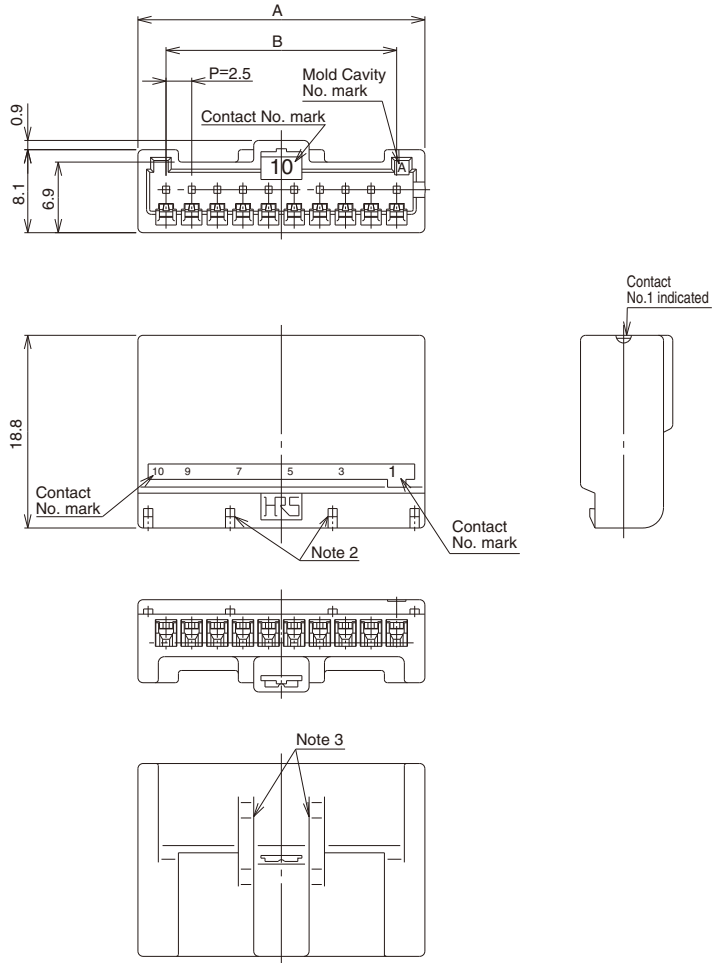
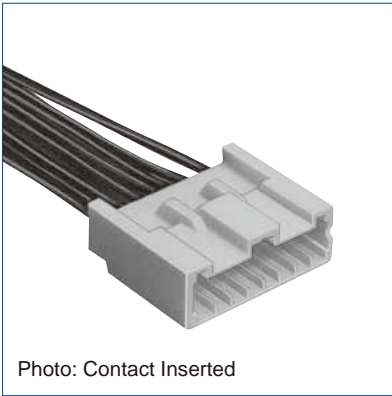

Unit : mm

Part No.	HRS No.	No. of Contacts	A	B
DF1EA- 2EP-2.5C	541-0957-5	2	8.0	2.5
DF1EA- 3EP-2.5C	541-0958-8	3	10.5	5.0
DF1EA- 4EP-2.5C	541-0959-0	4	13.0	7.5
DF1EA- 5EP-2.5C	541-0960-0	5	15.5	10.0
DF1EA- 6EP-2.5C	541-0961-2	6	18.0	12.5
DF1EA- 9EP-2.5C	541-0964-0	9	25.5	20.0
DF1EA-10EP-2.5C	541-0965-3	10	28.0	22.5

Note 1 : A packaging quantity is delivered by the bag unit (100 pcs.). If needed, please order the products per bag. However, the quantity for delivery will be changed according to the Specific No.

Note 2 : In regard to 2 to 5 contacts, the retainer fixed convex portions are located at both ends.

Note 3 : 2 to 7 contacts do not contain two convex portions, which is different from the above figure.

Note 4 : Styles of 2 to 4 contacts partially differ from the above figures.

* Refer to page 11 for retainer.

Socket

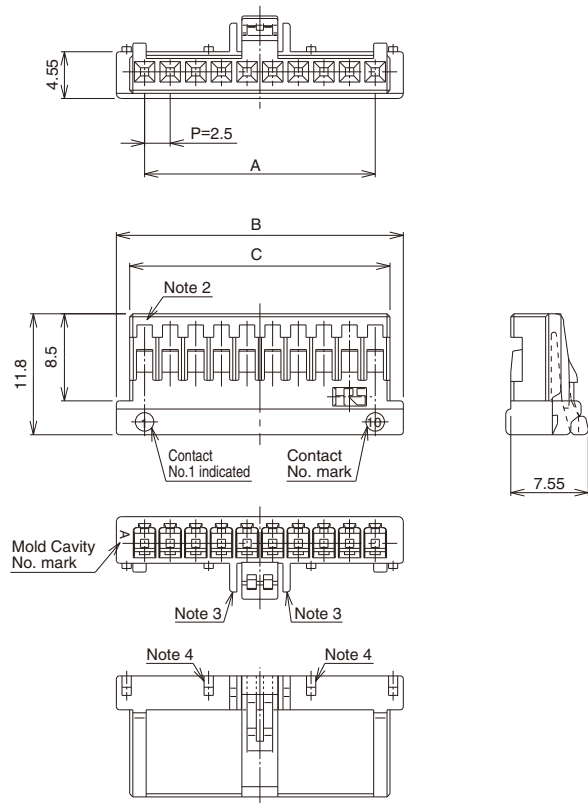
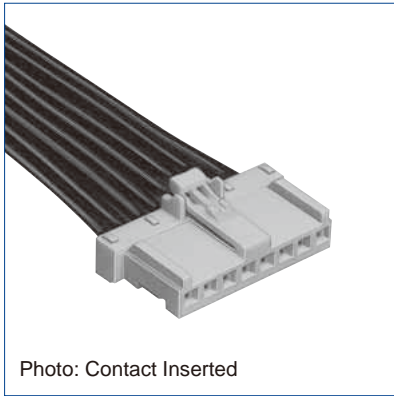

Unit : mm

Part No.	HRS No.	No. of Contacts	A	B	C
DF1E- 2S-2.5C	541-0811-0	2	2.5	8.0	5.4
DF1E- 3S-2.5C	541-0812-2	3	5.0	10.5	7.9
DF1E- 4S-2.5C	541-0813-5	4	7.5	13.0	10.4
DF1E- 5S-2.5C	541-0814-8	5	10.0	15.5	12.9
DF1E- 6S-2.5C	541-0815-0	6	12.5	18.0	15.4
DF1E- 7S-2.5C	541-0816-3	7	15.0	20.5	17.9
DF1E- 8S-2.5C	541-0817-6	8	17.5	23.0	20.4
DF1E- 9S-2.5C	541-0818-9	9	20.0	25.5	22.9
DF1E-10S-2.5C	541-0819-1	10	22.5	28.0	25.4
DF1E-11S-2.5C	541-0820-0	11	25.0	30.5	27.9
DF1E-12S-2.5C	541-0821-3	12	27.5	33.0	30.4
DF1E-14S-2.5C	541-0823-9	14	32.5	38.0	35.4
DF1E-15S-2.5C	541-0824-1	15	35.0	40.5	37.9

Note 1 : A packaging quantity is delivered by the bag unit (100 pcs.). If needed, please order the products per bag. However, the quantity for delivery will be changed according to spec number.

Note 2 : The 2 contact connector is equipped with the convex portion to prevent false-insertion.

Note 3 : The 2 consult Has no wall on the locking side

Note 4 : The 2 to 5 contacts contain the retainer fixed convex portions at both ends.

* Refer to page 11 for the retainer.

Retainer

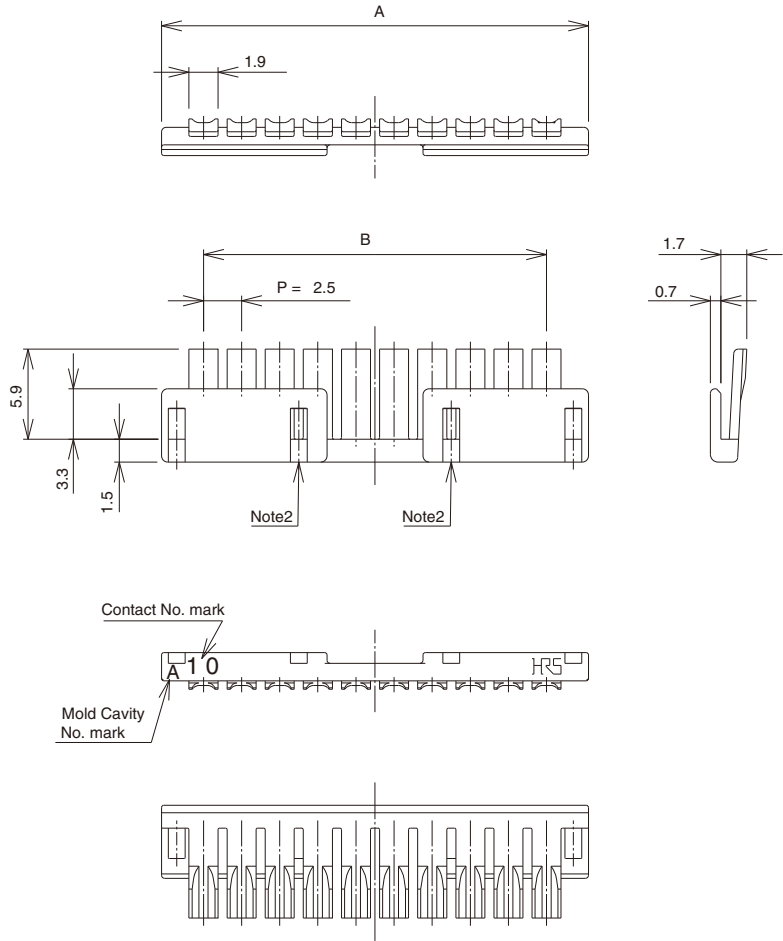
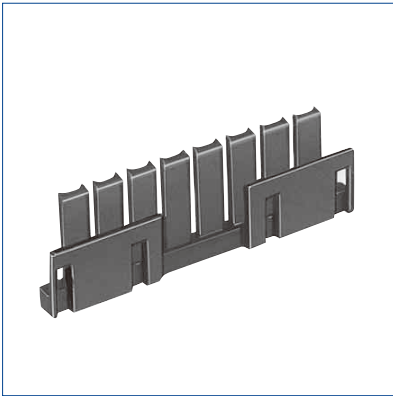

Unit : mm

Part No.	HRS No.	No. of Contacts	A	B
DF1E- 2RS/P-2.5	541-0971-6	2	8.0	2.5
DF1E- 3RS/P-2.5	541-0972-9	3	10.5	5.0
DF1E- 4RS/P-2.5	541-0973-1	4	13.0	7.5
DF1E- 5RS/P-2.5	541-0974-4	5	15.5	10.0
DF1E- 6RS/P-2.5	541-0975-7	6	18.0	12.5
DF1E- 8RS/P-2.5	541-0977-2	8	23.0	17.5
DF1E-10RS/P-2.5	541-0979-8	10	28.0	22.5

Note 1 : A packaging quantity is delivered by the bag unit (100 pcs.). If needed, please order the products per bag. However, the quantity for delivery will be changed according to spec number.

Note 2 : The 2 to 4 contacts contain socket and plug fixed holes at both ends.

* This retainer can be used together with the socket and In-line plug.

■ Plug Crimping Contact

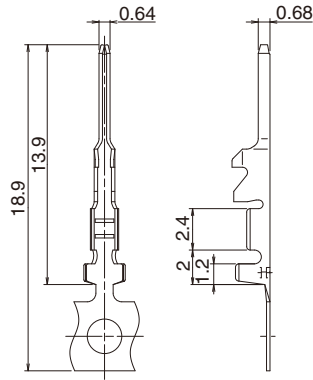

● Reel Contact Applicable Tool : Applicator

Part No.	HRS No.	Applicable Cable (Tin Plated Annealing Copper Wire)				Purchase Unit	Finish
		UL Style	Jacket Diameter	AWG	Wire Construction		
DF1E-2022PCF	541-0937-8	UL1007 UL1061	1.2 to 1.9mm	20 AWG	21/0.18	10000	Tin plated
DF1E-2022PCFA	541-1003-0			22 AWG	17/0.16		Gold plated
DF1E-2428PCF	541-0939-3			20 AWG	21/0.18		Tin plated
				22 AWG	17/0.16		
			24 AWG	11/0.16			
			26 AWG	7/0.16			
DF1E-2428PCFA	541-1005-6		28 AWG	7/0.127	Gold plated		
			24 AWG	11/0.16			
		26 AWG	7/0.16				
		28 AWG	7/0.127				

Note : When using cables other than those specified, contact a Hirose sales representative.

● Loose Contact Applicable Tool : Manual Crimping Tool

Part No.	HRS No.	Applicable Cable (Tin Plated Annealing Copper Wire)				Purchase Unit	Finish
		UL Style	Jacket Diameter	AWG	Wire Construction		
DF1E-2022PCA	541-1004-3	UL1007	1.8mm	20 AWG	21/0.18	100	Gold plated
DF1E-2428PC	541-0940-2		1.6mm	22 AWG	17/0.16		Tin plated
			1.5mm	24 AWG	11/0.16		
			1.3mm	26 AWG	7/0.16		
			1.2mm	28 AWG	7/0.127		

Note : Only the above cables are suitable when using the manual crimping tool.

■ Socket Crimping Contact

● DF1E-2022SCF (A)

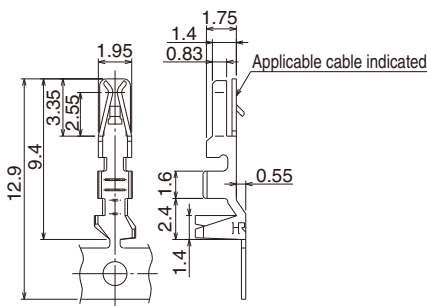

● DF1B - * * * * SCF (A)

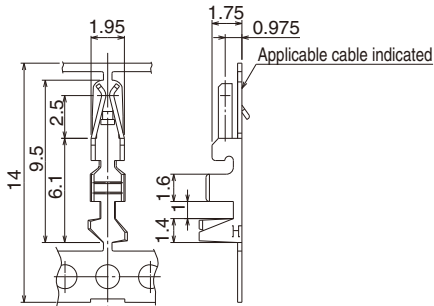

● Reel Contact Applicable Tool : Applicator

Part No.	HRS No.	Applicable Cable (Tin Plated Annealing Copper Wire)				Purchase Unit	Finish
		UL Style	Jacket Diameter	AWG	Wire Construction		
DF1E-2022SCF	541-0999-5	UL1007 UL1061	1.2 to 1.9mm	20 AWG	21/0.18	10000	Tin plated
DF1E-2022SCFA	541-1001-5			22 AWG	17/0.16		Gold plated
DF1B-2022SCF	541-0223-1		20 AWG	21/0.18	Tin plated		
DF1B-2022SCFA	541-0662-1		22 AWG	17/0.16	Gold plated		
			24 AWG	11/0.16	Tin plated		
DF1B-2428SCF	541-0678-1		26 AWG	7/0.16			Gold plated
			28 AWG	7/0.127			
DF1B-2428SCFA	541-0680-3		24 AWG	11/0.16	Gold plated		
			26 AWG	7/0.16			
			28 AWG	7/0.127			
DF1B-30SCF	541-0682-9		0.6 to 1.2mm	30 AWG	7/0.1		Tin plated
DF1B-30SCFA	541-0684-4		0.6 to 1.2mm	30 AWG	7/0.1		Gold plated

Note : When using cables other than those specified, contact a Hirose sales representative.

● Loose Contact Applicable Tool : Manual Crimping Tool

Part No.	HRS No.	Applicable Cable (Tin Plated Annealing Copper Wire)				Purchase Unit	Finish
		UL Style	Jacket Diameter	AWG	Wire Construction		
DF1E-2022SC	541-1000-2	UL1007	1.8mm	20 AWG	21/0.18	100	Tin plated
			1.6mm	22 AWG	17/0.16		Gold plated
DF1E-2022SCA	541-1002-8		1.8mm	20 AWG	21/0.18		Gold plated
			1.6mm	22 AWG	17/0.16		
DF1B-2022SC	541-0224-4		1.8mm	20 AWG	21/0.18		Tin plated
			1.6mm	22 AWG	17/0.16		
DF1B-2022SCA	541-0663-4		1.8mm	20 AWG	21/0.18		Gold plated
			1.6mm	22 AWG	17/0.16		
DF1B-2428SC	541-0679-4		1.5mm	24 AWG	11/0.16		Tin plated
			1.3mm	26 AWG	7/0.16		
			1.2mm	28 AWG	7/0.127		
DF1B-2428SCA	541-0681-6		1.5mm	24 AWG	11/0.16		Gold plated
			1.3mm	26 AWG	7/0.16		
			1.2mm	28 AWG	7/0.127		
DF1B-30SC	541-0683-1	1.1mm	30 AWG	7/0.1	Tin plated		
DF1B-30SCA	541-0685-7	1.1mm	30 AWG	7/0.1	Gold plated		

Note : Only the above cables are suitable when using the manual crimping tool.

◆ Crimping Tools

Item	Part No.	HRS No.	Applicable Contact
Applicator	AP105-DF1E-2022S	901-4561-0	DF1E-2022SCF DF1E-2022SCFA
	AP105-DF1B-2022S ◎	901-4510-9	DF1B-2022SCF DF1B-2022SCFA
	AP105-DF1B-2428S ◎	901-4518-0	DF1B-2428SCF DF1B-2428SCFA
	AP105-DF1B-30S ◎	901-4517-8	DF1B-30SCF DF1B-30SCFA
	AP105-DF1B-2022P ◎	901-4509-0	DF1E-2022PCF DF1E-2022PCFA
	AP105-DF1B-2428P ◎	901-4521-5	DF1E-2428PCF DF1E-2428PCFA
Main Press Unit	CM-105C ◎	901-0001-0	—
Manual Crimping Tool	HT102/DF1E-2022S	550-0277-1	DF1E-2022SC DF1E-2022SCA
	DF1B-TA2022SHC ◎	550-0182-7	DF1B-2022SC DF1B-2022SCA
	DF1B-TA2428SHC ◎	550-0209-1	DF1B-2428SC DF1B-2428SCA
	DF1B-TA30SHC ◎	550-0211-3	DF1B-30SC DF1B-30SCA
	HT102/DF1BE-2022P	550-0278-4	DF1E-2022PC DF1E-2022PCA
	HT102/DF1BE-2428P	550-0279-7	DF1E-2428PC DF1E-2428PCA
Contact Extraction Tool	DF-C-PO (B)	550-0179-2	DF1E-2022SC (F) (A) DF1B- * * * * SC (F) (A) DF1E- * * * * PC (F) (A)

Note 1 : Add "◎" to the last number of the product, in order to use DF1B series tools, which have been conventionally merchandized.

Note 2 : If any trouble has occurred due to other tools, which are not designated by Hirose, Hirose won't guarantee any products.

Note 3 : Please perform crimping work in accordance with the "Crimp Quality Standard" (ETAD-H0947-00, ETAD-H0949-00) and the "Crimp Condition Table".

Note.4 : Please contact a Hirose sales representative to request the tooth profile drawings when using other than tools specified by our company.

◆ Crimping Precautions

■ Items Required Prior to Crimping

The work-related documents shown below are required before starting the harness assembly.

(The ● mark represents required documents.)

Please contact your Hirose sales representative if you do not have these documents.

Document Title	Description	Automatic Crimping Machine	Hand Crimping Tool	Remarks
(1) Crimping Machine Main Unit Instruction Manual	Explanation of main press unit	●	—	Bundled with purchase of main press machine unit.
(2) Applicator Instruction Manual	Crimp Method	●	—	Bundled with purchase of applicator.
(3) Applicator Spare Parts List	Applicator Installation Instruction	●	—	
(4) Crimp Conditions	Crimp height, tensile strength standard value	●	—	
(5) Crimp Quality Standards	Various standards for crimping conditions	●	—	Bundled with purchase of hand tool.
(6) Hand Tool Operating Instructions	Crimp method, crimp height and tensile height standard value	—	●	

■ Tools

- Use tools designated by Hirose when crimping.
- Crimping performed using tools other than those specified is outside the scope of warranty.
- The operating instructions are available for the crimping machine and the applicator. Be sure to carefully read the operating instructions manual before beginning work.

■ Applicable Cables

Check that the cables to be used are within the applicable range.

If you intend to use a cable other than those recommended, contact a sales representative.

[Precautions]

- Cables applicable to crimping connectors are tin-plated stranded soft-copper wire.
- Avoid crimping solid wire, wires with polyester threads or tin coated wires.
- Avoid crimping two cables together.
- The crimp height setting values (Note 1) may vary between tin-plated and gold-plated terminals even if the same electric wires are used.
- The crimp height setting values (Note 1) may vary depending on the difference in the core wire configuration even if the computed cross-sectional area is the same.

Note 1 : The crimp height is an important item that determines crimping quality. We execute crimping tests for each electric wire to ensure the optimal value for the crimp height with high precision, thereby ensuring optimal setup values.

◆ Precautions

1. Cleaning Condition	Refer to Wire-to-Board Connector Use Hand book.
2. Connection Condition	Refer to Wire-to-Board Connector Use Hand book.
3. Cautions	<ul style="list-style-type: none"> ■ To remove the connector, if the connector is forcedly removed, it will cause connector damage. If the connector is hardly removed, slightly push the connector once, and then remove it using the lock. ■ In some method for laying the cable within equipment, a tension may be applied to the cable so as to remove the contact. In this case, it is recommended to use the retainer. ■ Incomplete insertion of the contact can be prevented by mounting a retainer; however, mounting of a retainer might not be possible when the contact protrudes beyond the socket. Insert the contact securely and then mount the retainer. ■ The color phase of this product may be slightly different from that of the forming product according to the manufacturing lot and future storage conditions, however the difference doesn't affect the performance. ■ Black spots may appear on the mold resin but this does not affect the product quality.
4. Precautions	<p>Please refer to the following documents when handling the product.</p> <ul style="list-style-type: none"> ■ Crimp Quality Standard (ETAD-H0947-00, ETAD-H0949-00) ■ Wire-to-Board Connector Use Handbook

May.1.2024 Copyright 2024 HIROSE ELECTRIC CO., LTD. All Rights Reserved.



HIROSE ELECTRIC CO.,LTD.

2-6-3,Nakagawa Chuoh,Tsuzuki-Ku,Yokohama-Shi 224-8540,JAPAN
<https://www.hirose.com/>

Looking for pricing, stock, or lifecycle information?

Click below to explore more details on WIN SOURCE:

- ⊖ [View DF1EC-10P-2.5DSA\(36\) on WIN SOURCE](#)
- ⊖ [Hirose Electric Co Ltd Information](#)

Optimize Your Supply Chain with WIN SOURCE Solutions

- ✓ Global Sourcing Solution
- ✓ Obsolete Management
- ✓ Cost Control Management
- ✓ Shortage Management
- ✓ Alternative Solution
- ✓ Excess Inventory Management