



# THE DATASHEET OF GBPC2506M



## 15A, 25A, 35A, 50V - 1000V Standard Bridge Rectifier

### FEATURES

- Glass passivated chip junction
- Integrally molded heatsink provide very low thermal resistance for maximum heat dissipation
- Typical  $I_R$  less than  $0.2\mu A$
- High surge current capability
- UL Recognized File # E-326243
- RoHS Compliant

### APPLICATIONS

- Switching mode power supply (SMPS)
- AC to DC converter

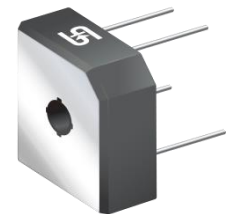
### MECHANICAL DATA

- Case: GBPC  
GBPC-W: Wire structure  
GBPC40-M: Terminal cathode parallel to anode
- Molding compound meets UL 94V-0 flammability rating
- Terminal: Matte tin plated leads, solderable per J-STD-002
- Meet JESD 201 class 1A whisker test
- Mounting torque: 20 in-lbs maximum
- Polarity: As marked
- Weight: 16.95g (approximately)

KEY PARAMETERS		
PARAMETER	VALUE	UNIT
$I_F$	15, 25, 35	A
$V_{RRM}$	50 - 1000	V
$I_{FSM}$	300, 400	A
$T_{JMAX}$	150	°C
Package	GBPC	
Configuration	Quad	



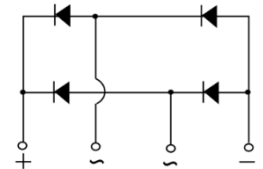
GBPC



GBPC-W



GBPC-M



### ABSOLUTE MAXIMUM RATINGS ( $T_A = 25^\circ C$ unless otherwise noted)

PARAMETER	SYMBOL	GBPC15, 25, 35							UNIT
		005	01	02	04	06	08	10	
Repetitive peak reverse voltage	$V_{RRM}$	50	100	200	400	600	800	1000	V
Reverse voltage, total rms value	$V_{R(RMS)}$	35	70	140	280	420	560	700	V
Forward current	GBPC15	15							A
	GBPC25	25							A
	GBPC35	35							A
Peak forward surge current, 8.3ms single half sine-wave superimposed on rated load	GBPC15	300							A
	GBPC25	400							A
	GBPC35	400							A
Rating for fusing ( $t < 8.3ms$ )	GBPC15	373							$A^2s$
	GBPC25	664							$A^2s$
	GBPC35	664							$A^2s$
Junction temperature	$T_J$	- 55 to +150							°C
Storage temperature	$T_{STG}$	- 55 to +150							°C

<b>THERMAL PERFORMANCE</b>			
<b>PARAMETER</b>	<b>SYMBOL</b>	<b>TYP</b>	<b>UNIT</b>
Junction-to-case thermal resistance	$R_{\theta JC}$	1.5	°C/W

<b>ELECTRICAL SPECIFICATIONS</b> ( $T_A = 25^\circ\text{C}$ unless otherwise noted)						
<b>PARAMETER</b>		<b>CONDITIONS</b>	<b>SYMBOL</b>	<b>TYP</b>	<b>MAX</b>	<b>UNIT</b>
Forward voltage per diode <sup>(1)</sup>	GBPC15	$I_F = 7.5\text{A}, T_J = 25^\circ\text{C}$	$V_F$	-	1.1	V
	GBPC25	$I_F = 12.5\text{A}, T_J = 25^\circ\text{C}$		-	1.1	V
	GBPC35	$I_F = 17.5\text{A}, T_J = 25^\circ\text{C}$		-	1.1	V
Reverse current @ rated $V_R$ per diode <sup>(2)</sup>		$T_J = 25^\circ\text{C}$	$I_R$	-	5	$\mu\text{A}$

**Notes:**

1. Pulse test with  $PW = 0.3\text{ms}$
2. Pulse test with  $PW = 30\text{ms}$

<b>ORDERING INFORMATION</b>		
<b>ORDERING CODE<sup>(1)</sup></b>	<b>PACKAGE</b>	<b>PACKING</b>
GBPC*x	GBPC	50 / Tray
GBPC*xM	GBPC-M	50 / Tray
GBPC*xW	GBPC-W	50 / Tray

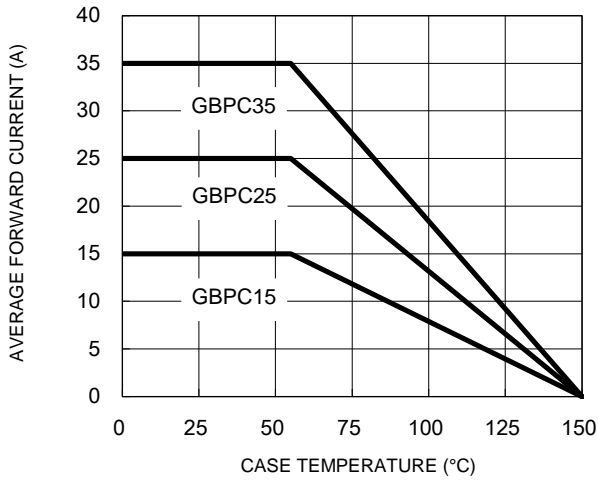
**Notes:**

1. "\*" defines current from 15A (GBPC15x/GBPC15xM/GBPC15xW) to 35A (GBPC35x/GBPC35xM/GBPC35xW), "x" defines voltage from 50V(GBPC\*005/GBPC\*005M/GBPC\*005W) to 1000V(GBPC\*10/GBPC\*10M/GBPC\*10W)

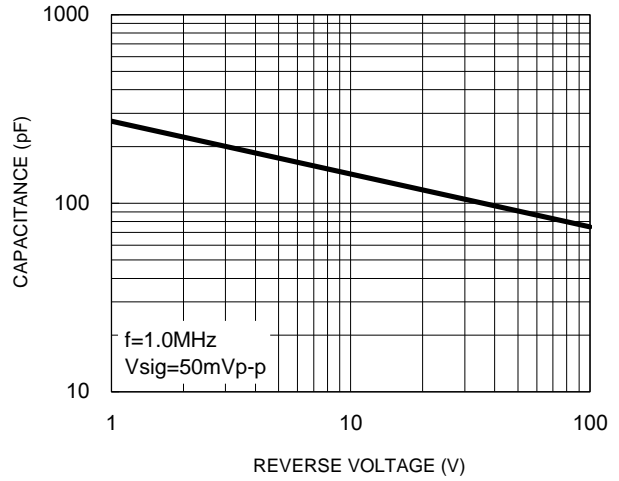
**CHARACTERISTICS CURVES**

( $T_A = 25^\circ\text{C}$  unless otherwise noted)

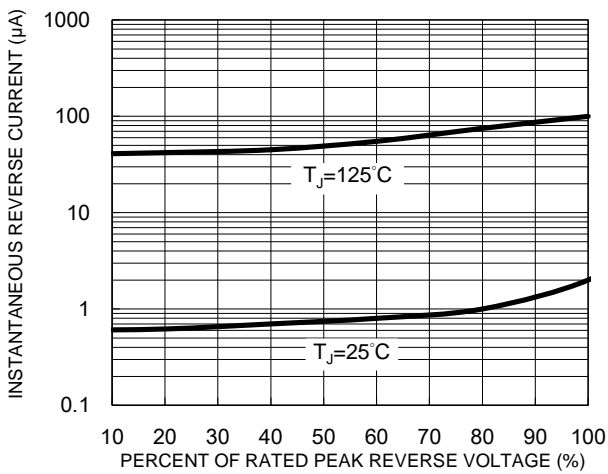
**Fig.1 Forward Current Derating Curve**



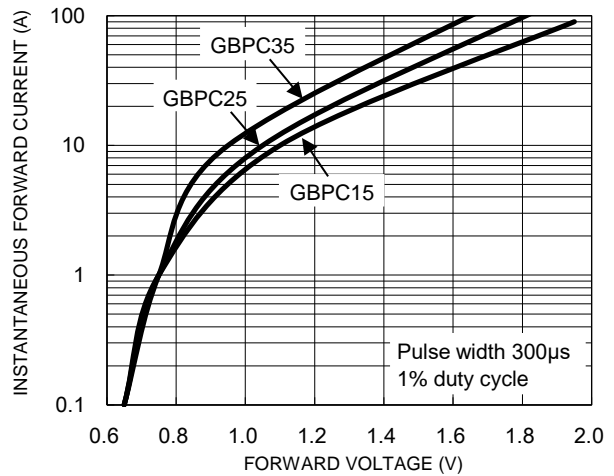
**Fig.2 Typical Junction Capacitance**



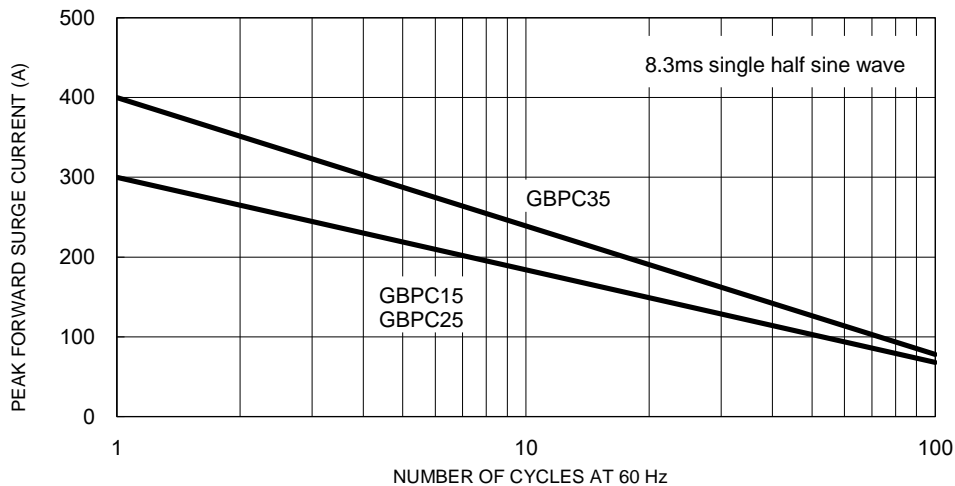
**Fig.3 Typical Reverse Characteristics**



**Fig.4 Typical Forward Characteristics**

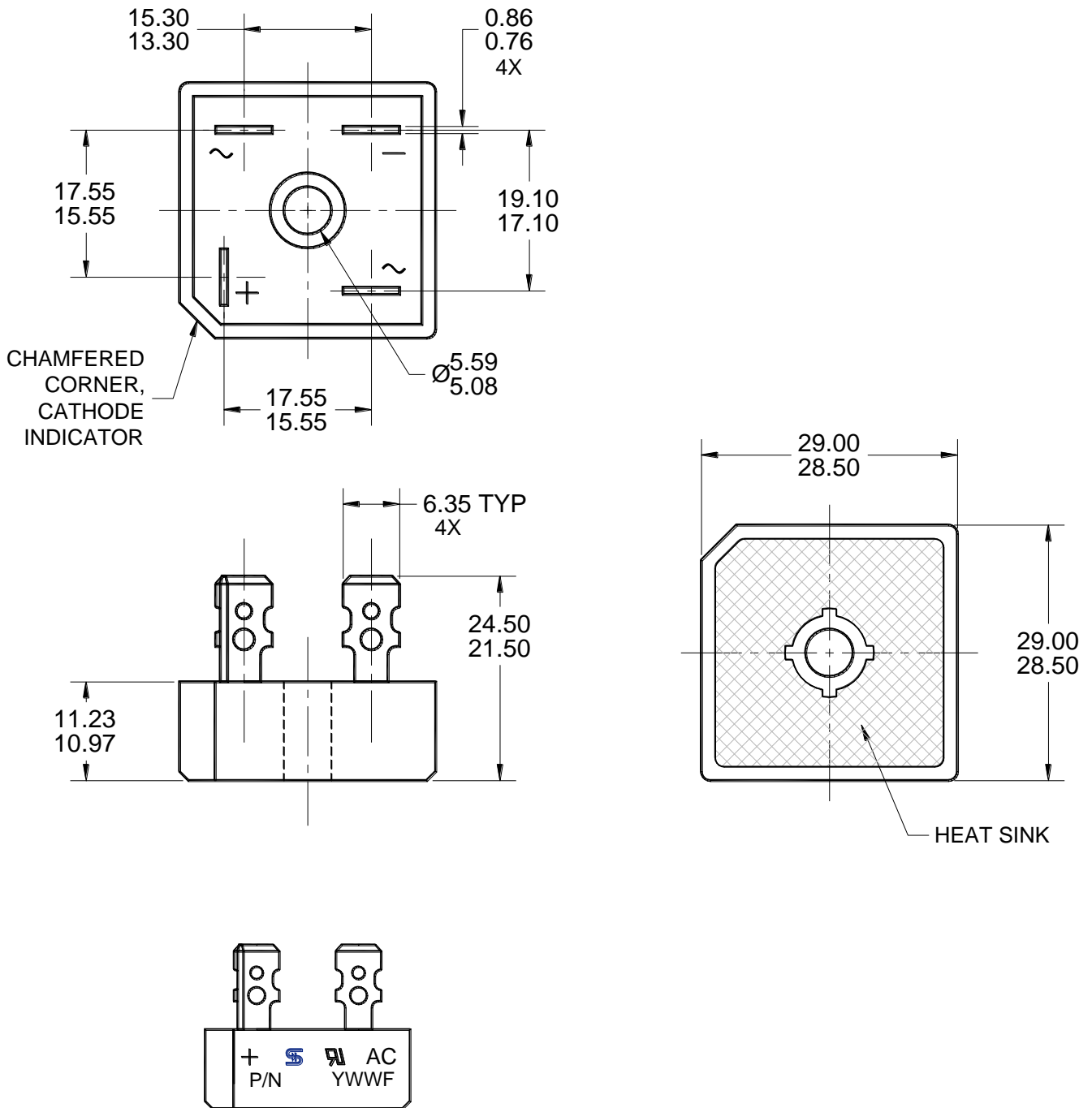


**Fig.5 Maximum Non-Repetitive Forward Surge Current**



**PACKAGE OUTLINE DIMENSIONS**

**GBPC**



**MARKING DIAGRAM**

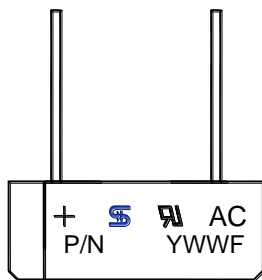
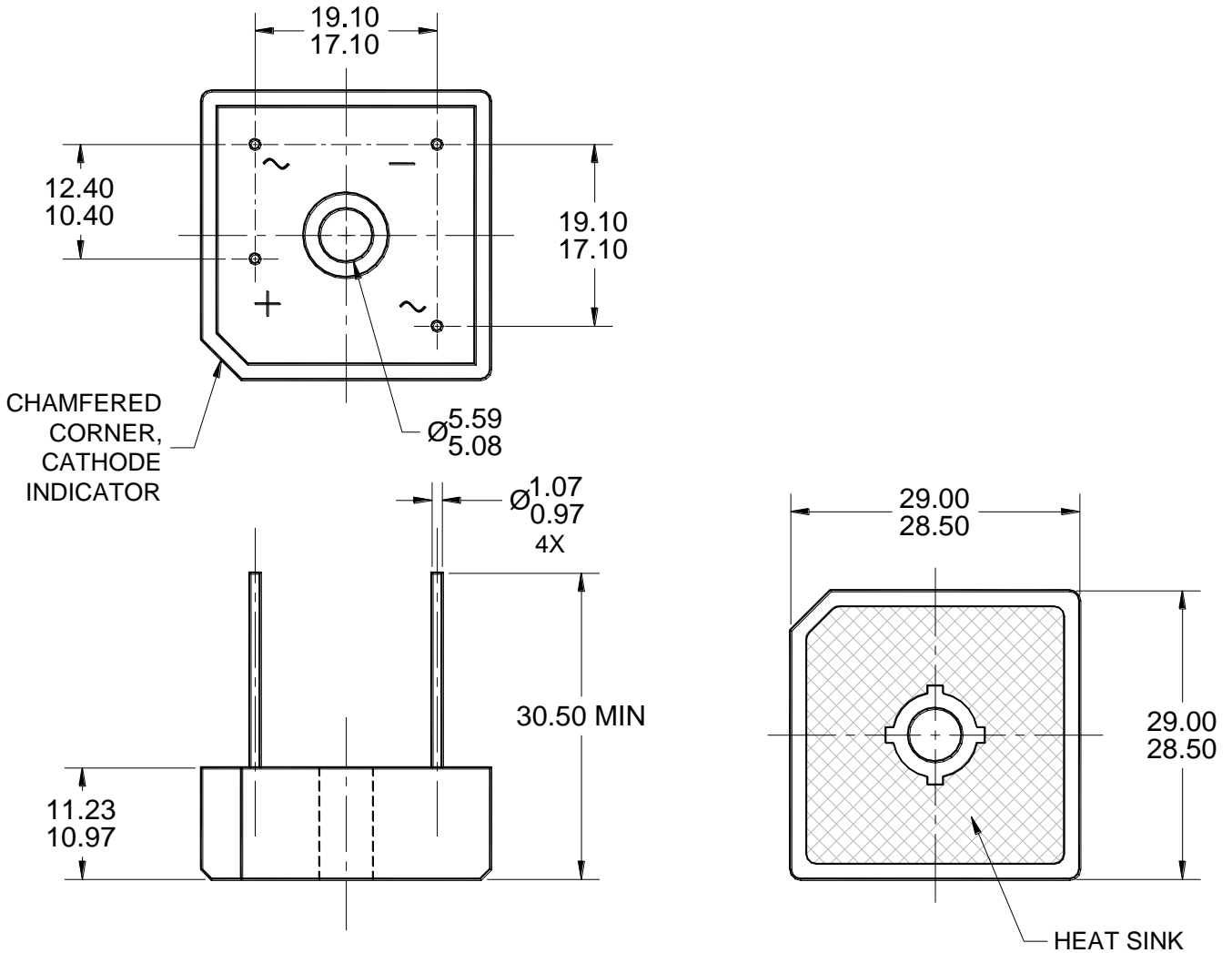
P/N = MARKING CODE  
 YWW = DATE CODE  
 F = FACTORY CODE

**NOTES: UNLESS OTHERWISE SPECIFIED**

1. ALL DIMENSIONS ARE IN MILLIMETERS.
2. DIMENSIONING AND TOLERANCING PER ASME Y14.5M-1994.
3. DWG NO. REF: HQ2SD07-GBPC-054 REV A.

**PACKAGE OUTLINE DIMENSIONS**

**GBPC-W**



**MARKING DIAGRAM**

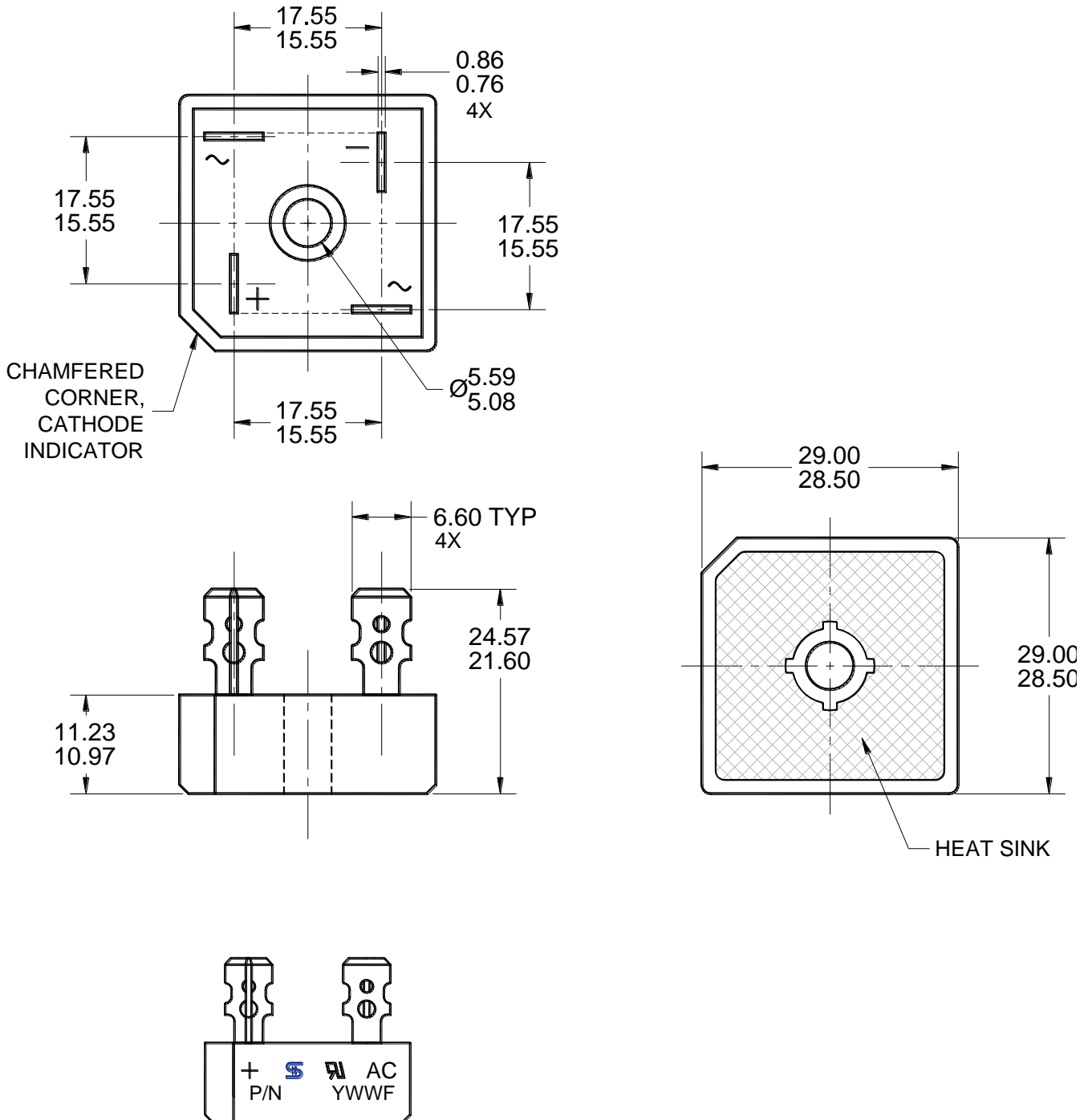
P/N = MARKING CODE  
 YWW = DATE CODE  
 F = FACTORY CODE

**NOTES: UNLESS OTHERWISE SPECIFIED**

1. ALL DIMENSIONS ARE IN MILLIMETERS.
2. DIMENSIONING AND TOLERANCING PER ASME Y14.5M-1994.
3. DWG NO. REF: HQ2SD07-GBPCW-056 REV A.

**PACKAGE OUTLINE DIMENSIONS**

**GBPC-M**



**MARKING DIAGRAM**

P/N = MARKING CODE  
 YWW = DATE CODE  
 F = FACTORY CODE

**NOTES: UNLESS OTHERWISE SPECIFIED**

1. ALL DIMENSIONS ARE IN MILLIMETERS.
2. DIMENSIONING AND TOLERANCING PER ASME Y14.5M-1994.
3. DWG NO. REF: HQ2SD07-GBPCM-055 REV A.

## **Notice**

Specifications of the products displayed herein are subject to change without notice. TSC or anyone on its behalf, assumes no responsibility or liability for any errors or inaccuracies.

Purchasers are solely responsible for the choice, selection, and use of TSC products and TSC assumes no liability for application assistance or the design of Purchasers' products.

Information contained herein is intended to provide a product description only. No license, express or implied, to any intellectual property rights is granted by this document. Except as provided in TSC's terms and conditions of sale for such products, TSC assumes no liability whatsoever, and disclaims any express or implied warranty, relating to sale and/or use of TSC products including liability or warranties relating to fitness for a particular purpose, merchantability, or infringement of any patent, copyright, or other intellectual property right.

The products shown herein are not designed for use in medical, life-saving, or life-sustaining applications. Customers using or selling these products for use in such applications do so at their own risk and agree to fully indemnify TSC for any damages resulting from such improper use or sale..

## Looking for pricing, stock, or lifecycle information?

Click below to explore more details on WIN SOURCE:

- ⊖ [View GBPC2506M](#) on WIN SOURCE
- ⊖ [Taiwan Semiconductor](#) Information

## Optimize Your Supply Chain with WIN SOURCE Solutions

- ✓ Global Sourcing Solution
- ✓ Obsolete Management
- ✓ Cost Control Management
- ✓ Shortage Management
- ✓ Alternative Solution
- ✓ Excess Inventory Management