

- **Smallest encapsulated 15 W Converter!**
Ultra compact size: 1.0" x 1.0" x 0.4"
- **Shielded metal case with isolated baseplate**
- **Ultrawide 4:1 input ranges:**
9-36 VDC or 18-75 VDC
- **Output voltage Trim**
- **5 Vout models with trim up to 6 VDC**
ideal for LDO applications
- **I/O isolation voltage 1600 VDC**
- **Very high efficiency up to 91%**
- **Operating temp. range:**
-40°C to +85°C
- **Remote On/Off control**
- **3-year product warranty**



The THN 15WI series is the latest generation of high performance DC/DC converter modules setting new standards concerning power density. This product with 15 W comes in a encapsulated, shielded metal package with dimensions of only 1.0" x 1.0" x 0.4" and occupies 50% (!) less board space. All models have ultra wide 4:1 input voltage range and precisely regulated output voltages. Advanced circuit design provides high efficiency up to 87% which allows an operating temperature range of -40°C to +85°C (with derating) Further features include remote On/Off and trimmable output. Typical applications for these converters are battery operated equipment, mobile instrumentation, distributed power architectures in communication and industrial electronics and everywhere where space on PCB is critical.

Models						
Order Code	Input Voltage Range	Output 1		Output 2		Efficiency typ.
		Vnom	I _{max}	Vnom	I _{max}	
THN 15-2410WI	9 - 36 VDC (24 VDC nom.)	3.3 VDC	4'000 mA			86 %
THN 15-2411WI		5 VDC	3'000 mA			86 %
THN 15-2411WI-A1		5 VDC	3'000 mA			86 %
THN 15-2412WI		12 VDC	1'300 mA			87 %
THN 15-2413WI		15 VDC	1'000 mA			87 %
THN 15-2415WI		24 VDC	625 mA			90 %
THN 15-2421WI		+5 VDC	1'500 mA	-5 VDC	1'500 mA	85 %
THN 15-2422WI		+12 VDC	625 mA	-12 VDC	625 mA	87 %
THN 15-2423WI		+15 VDC	500 mA	-15 VDC	500 mA	88 %
THN 15-2425WI		+24 VDC	315 mA	-24 VDC	315 mA	91 %
THN 15-4810WI	18 - 75 VDC (48 VDC nom.)	3.3 VDC	4'000 mA			86 %
THN 15-4811WI		5 VDC	3'000 mA			87 %
THN 15-4811WI-A1		5 VDC	3'000 mA			87 %
THN 15-4812WI		12 VDC	1'300 mA			87 %
THN 15-4813WI		15 VDC	1'000 mA			87 %
THN 15-4815WI		24 VDC	625 mA			91 %
THN 15-4821WI		+5 VDC	1'500 mA	-5 VDC	1'500 mA	85 %
THN 15-4822WI		+12 VDC	625 mA	-12 VDC	625 mA	86 %
THN 15-4823WI		+15 VDC	500 mA	-15 VDC	500 mA	87 %
THN 15-4825WI		+24 VDC	315 mA	-24 VDC	315 mA	91 %

Options	
Suffix A1	- Adjustable output up to 6VDC, ideal for low Ripple and Noise with an LDO regulator
THN-HS1	- Optional Heat Sink: www.tracopower.com/overview/thn-hs1

Note - ±24 Vout models: The output can also be used in serial circuit for single 48 VDC operation.

Input Specifications

Input Current	- At no load	24 Vin models: 45 mA typ. 48 Vin models: 20 mA typ.
Surge Voltage		24 Vin models: 50 VDC max. (100 ms max.) 48 Vin models: 100 VDC max. (100 ms max.)
Under Voltage Lockout		24 Vin models: 7 VDC min. / 8 VDC typ. / 8.8 VDC max. 48 Vin models: 14.5 VDC min. / 16 VDC typ. / 17.5 VDC max.
Reflected Ripple Current		30 mA_{p-p} typ.
Recommended Input Fuse		24 Vin models: 3'150 mA (slow blow) 48 Vin models: 1'600 mA (slow blow) (The need of an external fuse has to be assessed in the final application.)
Input Filter		Internal Pi-Type

Output Specifications

Output Voltage Adjustment		-10% to +20% (A1 & 24 Vout models) ±10% (other models) (single output models only) (By external trim resistor) See application note: www.tracopower.com/thn15wi-adj Output power must not exceed rated power!
Voltage Set Accuracy		±1% max.
Regulation	- Input Variation (V _{min} - V _{max})	single output models: 0.2% max. dual output models: 0.5% max.
	- Load Variation (0 - 100%)	single output models: 0.2% max. dual output models: 1% max. (Output 1) 1% max. (Output 2)
	- Cross Regulation (25% / 100% asym. load)	dual output models: 5% max.
Ripple and Noise (20 MHz Bandwidth)	- single output	3.3 Vout models: 75 mV_{p-p} typ. (w/ 1 μF X7R 10 μF TC) 5 Vout models: 75 mV_{p-p} typ. (w/ 1 μF X7R 10 μF TC) 12 Vout models: 100 mV_{p-p} typ. (w/ 1 μF X7R 10 μF TC) 15 Vout models: 100 mV_{p-p} typ. (w/ 1 μF X7R 10 μF TC) 24 Vout models: 100 mV_{p-p} typ. (w/ 6.8 μF X7R)
	- dual output	5 / -5 Vout models: 100 / 100 mV_{p-p} typ. (w/ 1 μF X7R 10 μF TC) 12 / -12 Vout models: 100 / 100 mV_{p-p} typ. (w/ 1 μF X7R 10 μF TC) 15 / -15 Vout models: 100 / 100 mV_{p-p} typ. (w/ 1 μF X7R 10 μF TC) 24 / -24 Vout models: 100 / 100 mV_{p-p} typ. (w/ 4.7 μF X7R)
Capacitive Load	- single output	3.3 Vout models: 12'000 μF max. 5 Vout models: 6'000 μF max. 12 Vout models: 1'000 μF max. 15 Vout models: 660 μF max. 24 Vout models: 200 μF max.
	- dual output	5 / -5 Vout models: 3'000 / 3'000 μF max. 12 / -12 Vout models: 520 / 520 μF max. 15 / -15 Vout models: 330 / 330 μF max. 24 / -24 Vout models: 100 / 100 μF max.
Minimum Load		Not required
Temperature Coefficient		±0.02 %/K max.
Start-up Time		30 ms max.
Short Circuit Protection		Continuous, Automatic recovery
Output Current Limitation		135 - 204% of I_{out} max. 150% typ. of I_{out} max.
Overvoltage Protection		112 - 164% of V_{out} nom.
Transient Response	- Response Time	250 μs typ. (25% Load Step)

All specifications valid at nominal voltage, resistive full load and +25°C after warm-up time, unless otherwise stated.

Safety Specifications

Standards	- IT / Multimedia Equipment	EN 60950-1 EN 62368-1 IEC 60950-1 IEC 62368-1 UL 60950-1 UL 62368-1
	- Certification Documents	www.tracopower.com/thn15wi-safety-cert
Pollution Degree		PD 2
Over Voltage Category		OVC I

EMC Specifications

EMI (Emissions)	- Conducted Emissions	EN 55032 class A (with external filter) EN 55032 class B (with external filter)
	- Radiated Emissions	EN 55032 class A (with external filter) EN 55032 class B (with external filter)
	External filter proposal:	www.tracopower.com/thn15wi-emc-filter
EMS (Immunity)	- Electrostatic Discharge	Air: EN 61000-4-2, ± 8 kV, perf. criteria A Contact: EN 61000-4-2, ± 6 kV, perf. criteria A
	- RF Electromagnetic Field	EN 61000-4-3, 10 V/m, perf. criteria A
	- EFT (Burst) / Surge	EN 61000-4-4, ± 2 kV, perf. criteria A EN 61000-4-5, ± 1 kV, perf. criteria A
	- Conducted RF Disturbances	Ext. input component: 220 μ F, 100 V EN 61000-4-6, 3 Vrms, perf. criteria A
	- PF Magnetic Field	Continuous: EN 61000-4-8, 100 A/m, perf. criteria A 1 s: EN 61000-4-8, 1000 A/m, perf. criteria A

General Specifications

Relative Humidity		95% max. (non condensing)
Temperature Ranges	- Operating Temperature	-40°C to +85°C -40°C to +90°C (with Heat Sink)
	- Case Temperature	+105°C max.
	- Storage Temperature	-55°C to +125°C
Power Derating	- High Temperature	2.5 %/K above 60°C 2.9 %/K above 70°C (with Heat Sink)
		See application note: www.tracopower.com/thn15wi-cc
Cooling System		Natural convection (20 LFM)
Remote Control	- Voltage Controlled Remote (passive = on)	On: 3.0 to 15 VDC or open circuit Off: 0 to 1.2 VDC or short circuit Refers to 'Remote' and '-Vin' Pin
	- Off Idle Input Current	2.5 mA typ.
	- Remote Pin Input Current	-0.5 to 1.0 mA
Altitude During Operation		5'000 m max.
Regulator Topology		Flyback Converter
Switching Frequency		360 - 440 kHz (PWM)
		400 kHz typ. (PWM)
Insulation System		Functional Insulation
Isolation Test Voltage	- Input to Output, 60 s	1'600 VDC
	- Input to Case, 60 s	1'000 VDC
	- Output to Case, 60 s	1'000 VDC
Isolation Resistance	- Input to Output, 500 VDC	1'000 M Ω min.
Isolation Capacitance	- Input to Output, 100 kHz, 1 V	1'000 pF max.
Reliability	- Calculated MTBF	1'400'000 h (MIL-HDBK-217F, ground benign)
Washing Process		According to Cleaning Guideline www.tracopower.com/info/cleaning.pdf

All specifications valid at nominal voltage, resistive full load and +25°C after warm-up time, unless otherwise stated.

Environment	- Vibration - Thermal Shock	MIL-STD-810F MIL-STD-810F
Housing Material		Copper, Nickel plated
Base Material		Non-conductive FR4 (UL 94 V-0 rated)
Potting Material		Epoxy (UL 94 V-0 rated)
Pin Material		Copper
Pin Foundation Plating		Nickel (2 - 3 μm)
Pin Surface Plating		Tin (3 - 5 μm), matte
Housing Type		Metal Case
Mounting Type		PCB Mount
Connection Type		THD (Through-Hole Device)
Footprint Type		1" x 1"
Soldering Profile		Lead-Free Wave Soldering 265°C / 10 s max.
Weight		15 g
Thermal Impedance	- Case to Ambient	18.2 K/W typ. 15.8 K/W typ. (with Heat Sink)
Environmental Compliance	- REACH Declaration - RoHS Declaration - SCIP Reference Number	www.tracopower.com/info/reach-declaration.pdf REACH SVHC list compliant REACH Annex XVII compliant www.tracopower.com/info/rohs-declaration.pdf Exemptions: 7(a), 7(c)-I (RoHS exemptions refer to the component concentration only, not to the overall concentration in the product (O5A rule).) 264a8e95-274a-487c-8a57-a20af46e4226

Additional Information

Supporting Documents	www.tracopower.com/overview/thn15wi
Frequently Asked Questions	www.tracopower.com/glossary-faq
Glossary	www.tracopower.com/info/glossary.pdf

Outline Dimensions

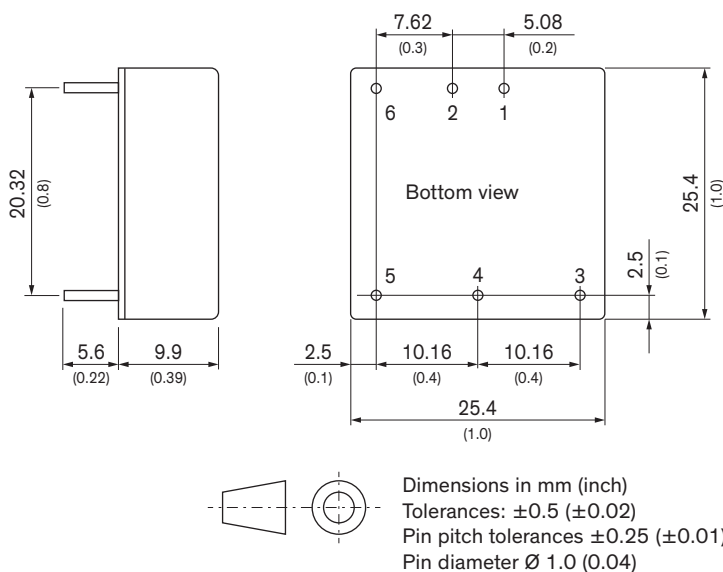

Pinout		
Pin	Single	Dual
1	+Vin (Vcc)	+Vin (Vcc)
2	-Vin (GND)	-Vin (GND)
3	+Vout	+Vout
4	Trim	Common
5	-Vout	-Vout
6	Remote On/Off	Remote On/Off

Looking for pricing, stock, or lifecycle information?

Click below to explore more details on WIN SOURCE:

 [View THN 15-4811WI on WIN SOURCE](#)

 [Traco Power Information](#)

Optimize Your Supply Chain with WIN SOURCE Solutions

-  Global Sourcing Solution
-  Obsolete Management
-  Cost Control Management
-  Shortage Management
-  Alternative Solution
-  Excess Inventory Management