



**THE DATASHEET OF  
AS1923A-BSTT-I**





**austriamicrosystems AG**

**is now**

**ams AG**

The technical content of this austriamicrosystems datasheet is still valid.

**Contact information:**

**Headquarters:**

ams AG

Tobelbaderstrasse 30

8141 Unterpremstaetten, Austria

Tel: +43 (0) 3136 500 0

e-Mail: [ams\\_sales@ams.com](mailto:ams_sales@ams.com)

Please visit our website at [www.ams.com](http://www.ams.com)

# AS1923

## Quad-Voltage Microprocessor Supervisory Circuit

### 1 General Description

The AS1923 microprocessor supervisory circuit was designed to monitor up to four system supply voltages without the need for external components, and asserts a single reset if any of the monitored supply voltages drops below its reset threshold.

The AS1923 features an active-low reset output that is asserted when any of the 4 monitored voltages are below their respective reset threshold. The reset output is open-drain with a weak internal pullup (10µA) to IN2. Reset remains low for a specified reset timeout period (120ms min) after all voltages have stabilized. The output is valid as long as the IN1 or IN2 input voltage remains >1V.

Minimal external component requirements, small size, and wide temperature range (-40 to +85°C) greatly improves reliability compared to individual supervisory circuits or discrete components.

A wide range of factory-trimmed threshold voltages are available to accommodate many different supply voltages/tolerances with minimal external component requirements.

Factory-trimmed options are available for monitoring +5.0, +3.3, +3.0, +2.5, +1.8, and -5.0V supplies with -5% and/or -10% tolerances. The device is also available with one or two user-adjustable threshold options (via external resistor-divider network) if non-standard voltage thresholds are required.

The AS1923 is available in an 6-pin SOT23 package.

### 2 Key Features

- Simultaneous Quad-Voltage Monitoring
- Precision Factory-Trimmed Reset Threshold Options: +5.0, +3.3, +3.0, +2.5, +1.8, and -5.0V
- User-Adjustable Voltage Monitoring Threshold Options
- Low Supply Current: 55µA
- Open-Drain – AS1923A
- 10µA Current Source Pullup – AS1923B
- Reset Timeout Period: 120ms
- RESET Valid to IN1 = 1V or IN2 = 1V
- Immune to Fast IN<sub>x</sub> Transients
- External Components not Required
- Guaranteed Performance: Operating Temperature Range = -40 to +85°C
- 6-pin SOT23 Package

### 3 Applications

The device is ideal for portable and battery-powered systems, embedded controllers, intelligent instruments, automotive systems, critical CPU monitoring, and any multi-supply application.

Figure 1. AS1923 - Typical Application

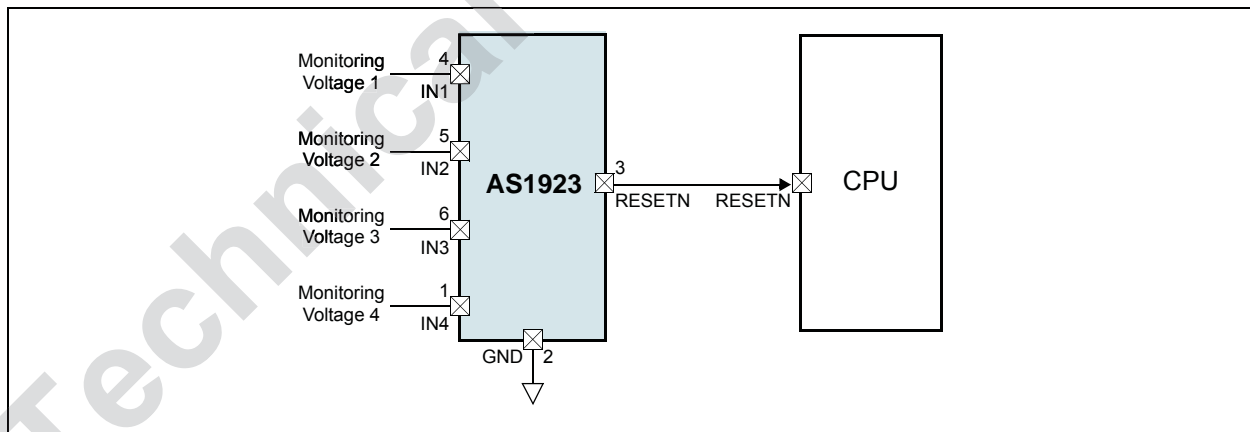

## 4 Pinout

### Pin Assignments

Figure 2. Pin Assignments (Top View)

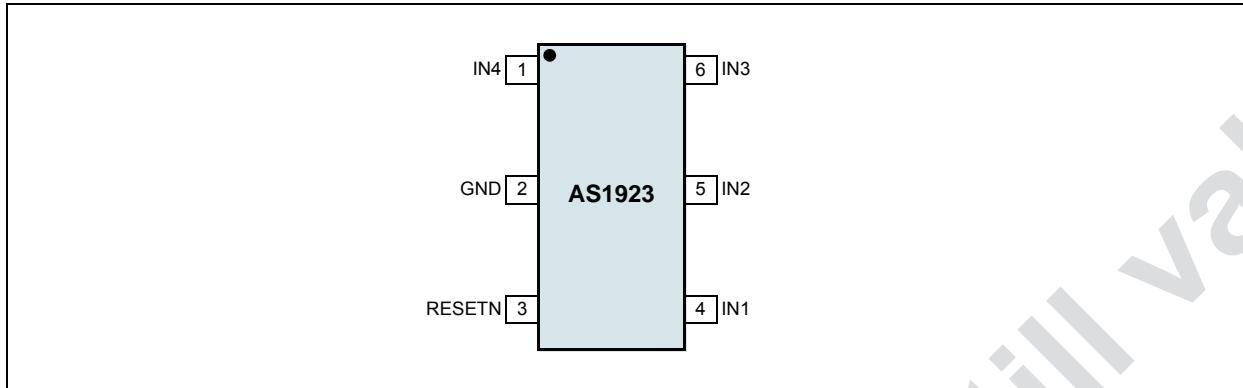

### Pin Descriptions

Table 1. Pin Descriptions

Pin Number	Pin Name	Description
1	IN4	Input Voltage 4. See Ordering Information on page 14 for monitored voltages.
2	GND	Ground
3	RESETN	Reset Output. AS1923A (see Ordering Information on page 14) supports an external pullup resistor; AS1923B contains an internal 10µA current source pullup. RESETN goes low (reset asserted) when any one of the IN <sub>x</sub> voltages goes below its specified threshold. After all inputs have stabilized, RESETN remains low for at least 120ms (min) before going high.
4	IN1	Input Voltage 1. See Ordering Information on page 14 for monitored voltages.
5	IN2	Input Voltage 2. See Ordering Information on page 14 for monitored voltages. <b>Note:</b> IN2 is the power supply input for the AS1923.
6	IN3	Input Voltage 3. See Ordering Information on page 14 for monitored voltages.

## 5 Absolute Maximum Ratings

Stresses beyond those listed in Table 2 may cause permanent damage to the device. These are stress ratings only, and functional operation of the device at these or any other conditions beyond those indicated in Electrical Characteristics on page 4 is not implied. Exposure to absolute maximum rating conditions for extended periods may affect device reliability.

Table 2. Absolute Maximum Ratings

Parameter	Min	Max	Units	Comments
<b>Electrical Parameters</b>				
IN1, IN2 (Monitored Voltage), IN3, IN4 to GND	-0.3	+7	V	
IN4 to GND (Device Variants M, N, O, and P, see Table 5 on page 14)	-7	+0.3	V	
RESETN to GND	-0.3	+6	V	
Latchup immunity				Class I Level A in accordance with EIA/JEDEC 78
<b>Continuous Power Dissipation</b>				
Continuous Power Dissipation (T <sub>AMB</sub> = +70°C)		696	mW	Derate 8.7mW/°C above +70°C
<b>Temperature Ranges and Storage Conditions</b>				
Junction Temperature		+150	°C	
Storage Temperature Range	-55	+150	°C	
Package Body Temperature		+260	°C	The reflow peak soldering temperature (body temperature) specified is in accordance with IPC/JEDEC J-STD-020 "Moisture/Reflow Sensitivity Classification for Non-Hermetic Solid State Surface Mount Devices". The lead finish for Pb-free leaded packages is matte tin (100% Sn).
Humidity non-condensing	5	85	%	
Moisture Sensitive Level		1		Represents a max. floor life time of unlimited

## 6 Electrical Characteristics

$V_{IN2} = +1V$  to  $+5.5V$ , Typ values @  $V_{IN2} = +3.0V$  to  $+3.3V$ ,  $T_{AMB} = +25^{\circ}C$  (unless otherwise specified).

Table 3. Electrical Characteristics

Symbol	Parameter <sup>1</sup>	Conditions	Min	Typ	Max	Units
$T_{amb}$	Operating Temperature Range		-40		85	$^{\circ}C$
$V_{IN2}$	Supply Voltage Range <sup>2,3</sup>		1.0		5.5	V
$I_{INx}$	Input Current	$V_{INx}$ = Input Threshold Voltage (Input Threshold Voltage of 1.8, 2.5, or 5V)		25	40	$\mu A$
		$V_{IN2}$ = Input Threshold Voltage (Input Threshold Voltage of 3.0 or 3.3V) <sup>4</sup>		55	115	
		$V_{INx} = 0$ to $V_{IN2}$ (Input Threshold Voltage = $+1.23V$ ) <sup>5</sup>	-0.1		0.1	
		$V_{IN1} = 1.5V$ (AS1923 K/L only)		0.4	1.5	
		$V_{INx} = -5V$ (Input Threshold Voltage = $-5V$ )		-15	-20	
$V_{TH}$	Reset Threshold Voltage	$V_{INx}$ Decreasing, $+5V$ (-5%) Threshold	4.50	4.63	4.75	V
		$V_{INx}$ Decreasing, $+5V$ (-10%) Threshold	4.25	4.38	4.50	
		$V_{INx}$ Decreasing, $+3.3V$ (-5%) Threshold	3.00	3.08	3.15	
		$V_{INx}$ Decreasing, $+3.3V$ (-10%) Threshold	2.85	2.93	3.00	
		$V_{INx}$ Decreasing, $+3.0V$ (-5%) Threshold	2.70	2.78	2.85	
		$V_{INx}$ Decreasing, $+3.0V$ (-10%) Threshold	2.55	2.63	2.70	
		$V_{INx}$ Decreasing, $+2.5V$ (-10%) Threshold	2.13	2.19	2.25	
		$V_{INx}$ Decreasing, $+1.8V$ (-10%) Threshold	1.53	1.58	1.62	
		$V_{INx}$ Increasing, $-5V$ (+5%) Threshold	-4.75	-4.63	-4.50	
$V_{INx}$ Increasing, $-5V$ (+10%) Threshold	-4.50	-4.38	-4.25			
$V_{TH}$	Adjustable Threshold	$V_{INx}$ Decreasing	1.20	1.23	1.26	V
	Threshold Voltage Temperature Coefficient			60		ppm/ $^{\circ}C$
$V_{HYS}$	Threshold Hysteresis			0.5		%
$t_{RD}$	Reset Delay	$V_{INx} = V_{TH}$ to $(V_{TH} - 50mV)$ , All Inputs Except $-5V$ , or $V_{INx} = V_{TH}$ to $(V_{TH} + 50mV)$ , $-5V$ Input Only		20		$\mu s$
$t_{RP}$	Reset Active Timeout Period		120	200	280	ms

Table 3. Electrical Characteristics (Continued)

Symbol	Parameter <sup>1</sup>	Conditions	Min	Typ	Max	Units
VOL	Output Low Voltage	VIN2 = 5V, ISINK = 2mA			0.4	V
		VIN2 = 2.5V, ISINK = 1.2mA			0.4	
		VIN1 = VIN2 = 1V, ISINK = 50µA			0.4	
VOH <sup>6</sup>	Output High Voltage, Output High Source Current	VIN2 > 2.55V, ISOURCE = 6µA (Reset Not Asserted)	0.8 x VIN2			V
IOH <sup>5</sup>	Output High Source Current	VIN2 ≥ 2.55V (Reset Not Asserted), VOUT ≥ 0.8 x VIN2	6	10		µA

- 100% production tested at TAMB = +25°C. Limits over temperature guaranteed by design.
- The device is powered from input IN2.
- The RESETN output is guaranteed to be in the correct state for IN1 or IN2 down to 1V.
- Monitored voltage at IN2 (+3.3V, +3.0V) is also the device power supply. Supply current split is 25µA for the resistor-divider network (for the monitored voltage) and 30µA for other circuits.
- Adjustable pin only.
- AS1923B only.

**Note:** All limits are guaranteed. The parameters with min and max values are guaranteed with production tests or SQC (Statistical Quality Control) methods.

## 7 Typical Operating Characteristics

$T_{amb} = +25^{\circ}\text{C}$ , unless otherwise noted

Figure 3. IN2 Input Current vs. IN2 Input Voltage

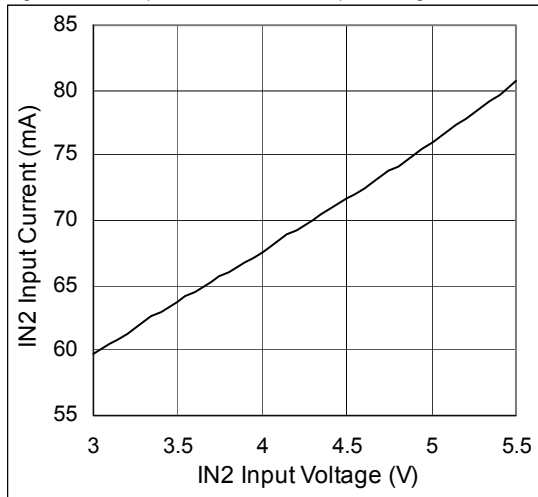

Figure 4. IN2 Input Current vs. Temperature

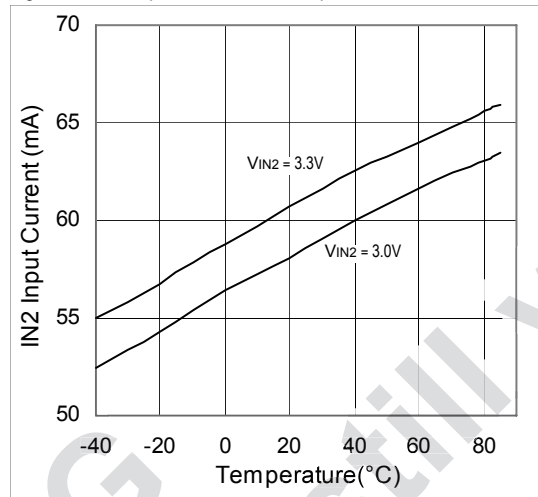

Figure 5. Reset Delay vs. Reset Threshold Overdrive;  
 $V_{IN2} = 3.0\text{V}$ , IN decreasing  $V_{IN2} = 3.0\text{V}$ , IN decreasing

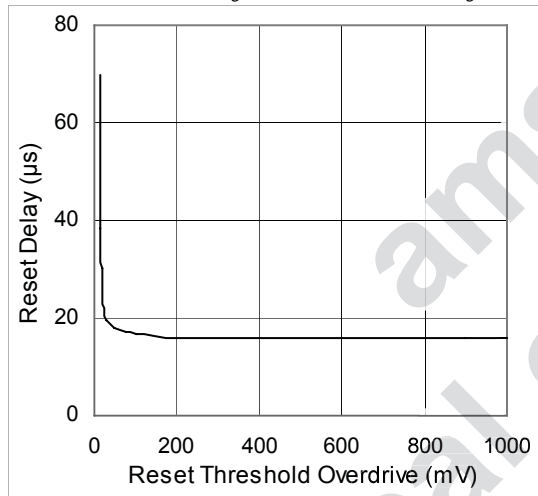

Figure 6. Reset Timeout Period vs. Temperature;

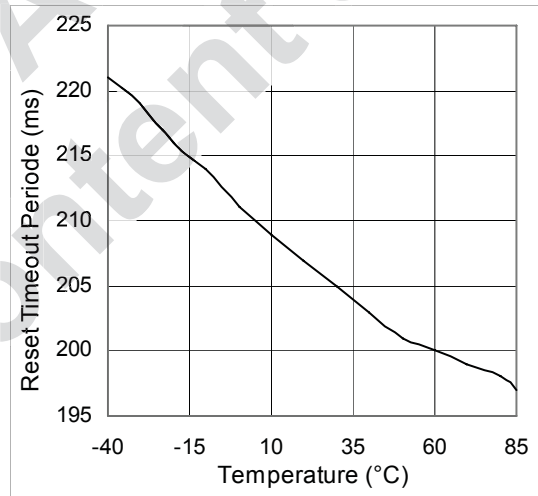

Figure 7. Normalized Threshold Error vs. Temperature;  
VIN2 = 3.0V

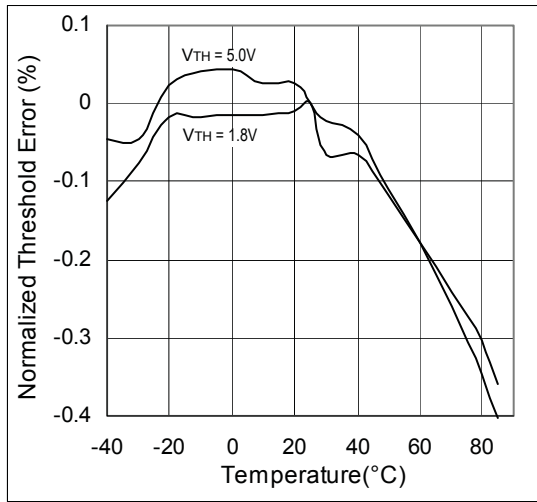

Figure 8. Reset Delay; VIN2 = 3.0V

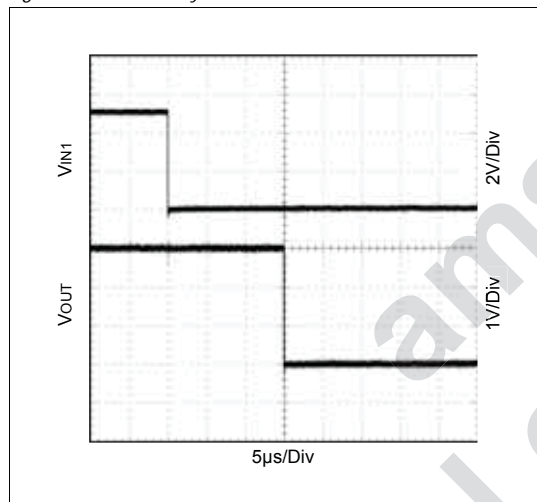
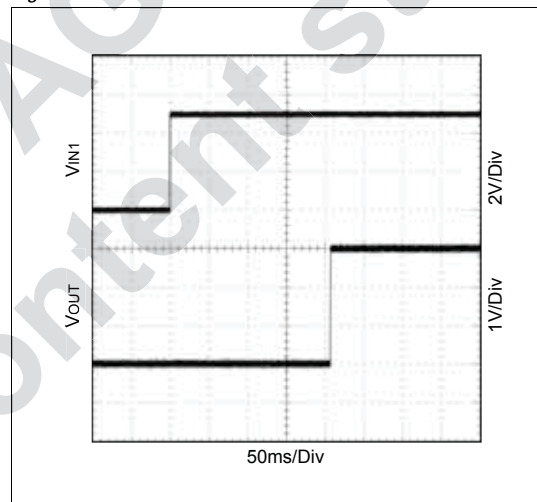

Figure 9. Reset Active Timeout Period; VIN2 = 3.0V



## 8 Detailed Description

The AS1923 is a very small, low-power, quad-voltage microprocessor supervisory circuit designed to maintain system integrity in multi-supply systems (see Figure 10). The device offers several factory-trimmed under-voltage threshold values that minimize or eliminate the need for external components.

Preset voltage monitoring values of +5.0, +3.3, +3.0, +2.5, +1.8, and -5.0V (see Ordering Information on page 14) are available for a wide range of applications such as telecommunications equipment, desktop and notebook computers, high-end printers, data storage equipment, and networking equipment applications.

The device is powered via the IN2 input (3.0 to 3.3V) and a reset is asserted if VIN1 or VIN2 is > 1V. For improved performance, the AS1923 was also designed to ignore fast INx transients.

Figure 10. AS1923 - Block Diagram

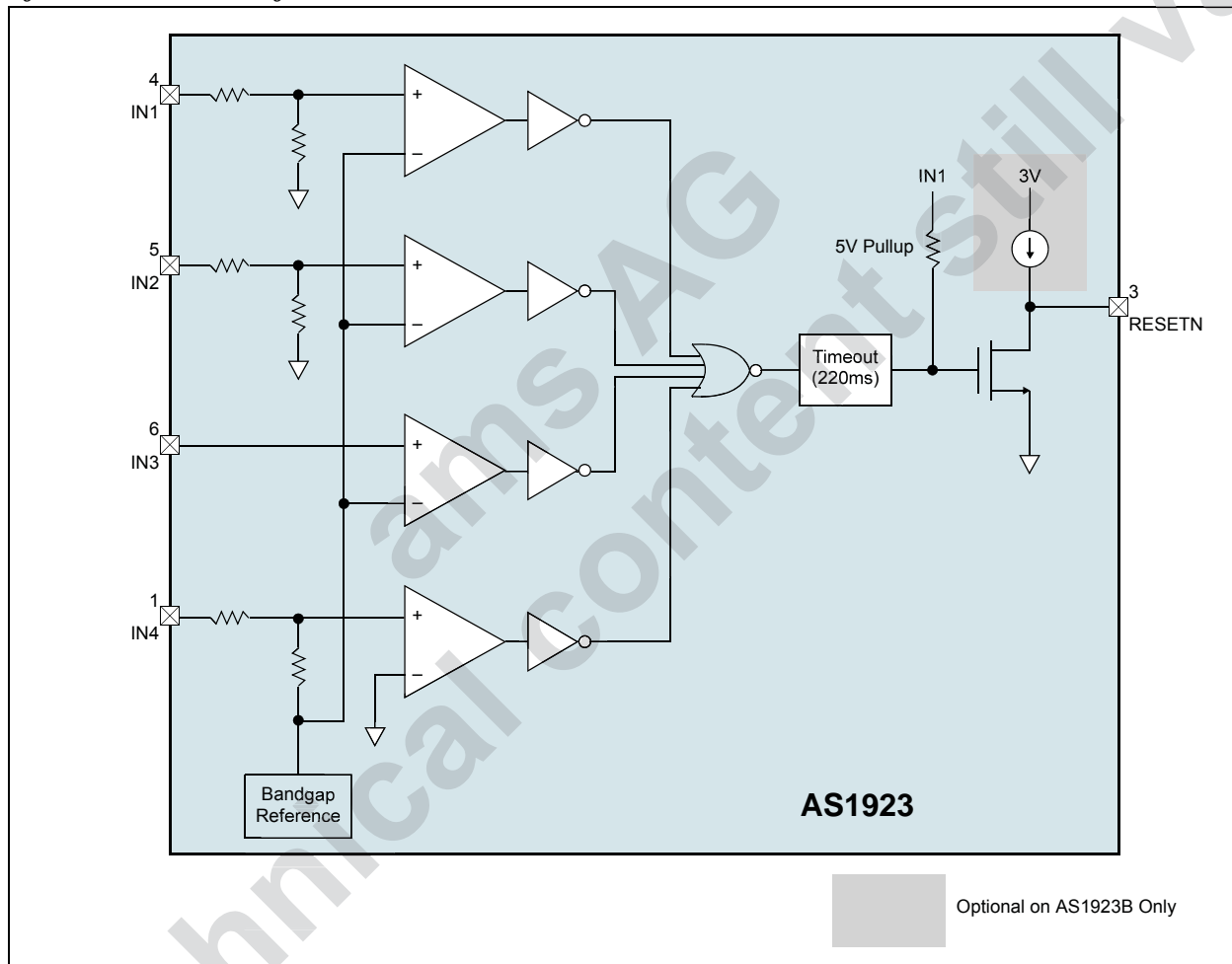

The quad-voltage monitor/reset circuitry includes an accurate bandgap reference, four precision comparators, and a series of internal trimmed resistor-divider networks to set the factory-trimmed reset threshold values.

The resistor networks scale the specified INx reset voltages to match the internal bandgap reference/comparator voltage. User-adjustable threshold options bypass the internal resistor networks and connect directly to one of the comparator inputs (an external resistor-divider network is required for threshold matching).

Each of the internal comparators has a typical hysteresis of 0.5% with respect to its reset threshold. This built-in hysteresis improves device immunity to ambient noise without significantly reducing threshold accuracy when an input sits at its specified reset voltage.

**Note:** Threshold voltage options (fixed and adjustable) are designated by the single-letter code in the model number (see Ordering Information on page 14).

## 9 Application Information

### Reset Output

The AS1923 RESETN output is asserted low when any of the monitored  $IN_x$  voltages drop below its specified reset threshold (above for -5V option) and remains asserted for the duration of the reset timeout period (120ms minimum) after all inputs have stabilized (Figure 11).

Figure 11. RESETN Output Timing Diagram

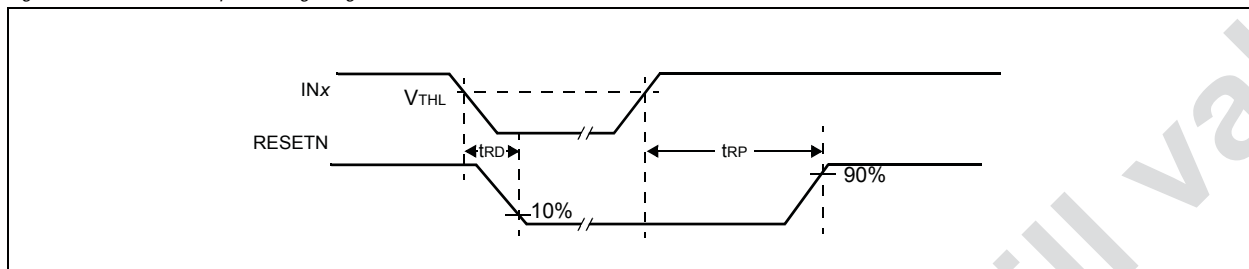

The AS1923B output driver is driven by an internal  $10\mu\text{A}$  current source pullup resistor. For most applications there is no need for an external pullup resistor to interface with other logic supplies.

**Note:** An external pullup resistor must not be connected to the AS1923B.

The AS1923A supports an external pullup resistor to any voltage from 0 to +5.5V if interfaced to non-standard logic supply voltages (see Figure 12).

Figure 12. Interfacing to Various Logic Supply Voltages

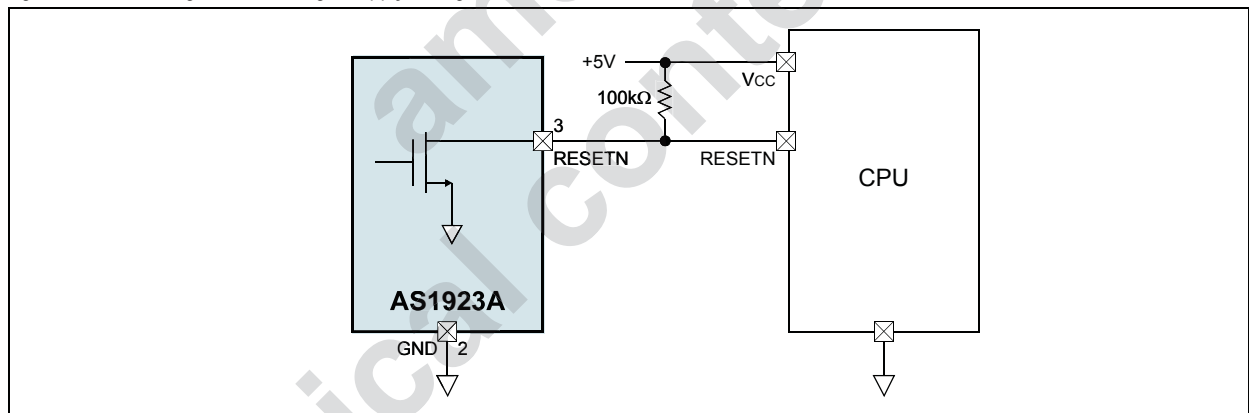

## User-Adjustable Thresholds

The AS1923 provides several voltage monitoring values as well as user-adjustable reset thresholds.

The threshold voltage at each adjustable IN $x$  input is typically 1.23V. To monitor a voltage >1.23V, connect a resistor-divider network to the circuit as shown in Figure 13.

Figure 13. Setting User-Adjustable Thresholds

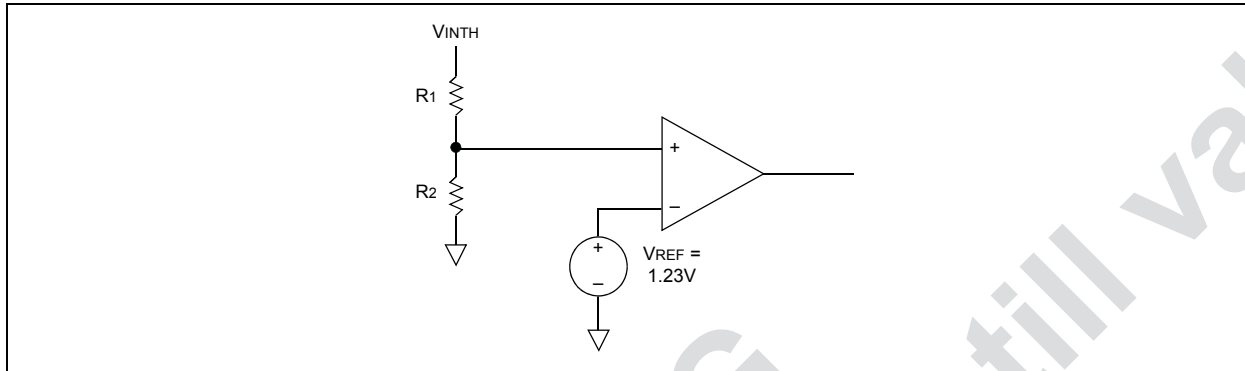

For the circuit shown in Figure 13, calculate R1 and R2 as:

$$V_{INTH} = 1,23V \times \frac{R_1 + R_2}{R_2} \quad (EQ 1)$$

or, calculated in terms of R1:

$$R_1 = R_2 \times \left( \frac{V_{INTH}}{1,23V} - 1 \right) \quad (EQ 2)$$

**Note:** Because the AS1923 has a guaranteed input current of  $\pm 0.1\mu A$  on its adjustable inputs, resistor values up to 100k $\Omega$  can be used for R2 with <1% error.

## Unused Inputs

The IN2 input must always be used for normal operation (AS1923 power-supply pin). Otherwise, in cases where one or more of the AS1923 monitoring inputs will not be used, these inputs must be tied to a supply voltage greater in magnitude than their specified threshold voltages.

### Notes:

1. For unused IN3 or IN4 applications with positive thresholds (fixed or adjustable), the inputs can be connected directly to the IN2 supply.
2. For unused IN4 options with negative thresholds, the input must be tied to a more negative supply.
3. Unused pins must not be connected to ground or allowed to float.

## Negative Voltage Monitoring Beyond -5V

The AS1923 is available with options to monitor -5V supplies using internally trimmed thresholds. In cases where monitored supplies are more negative than -5V, an external low-impedance resistor-divider network can be used as shown in Figure 14.

The current through the external resistor-divider should be greater than the input current for the -5V monitor options. For an input monitor current error of <1%, the resistor-divider current should be  $\geq 2\text{mA}$  (for  $\text{IN4} = 20\mu\text{A}$  max).

Figure 14. Negative Voltage Monitoring Beyond -5V

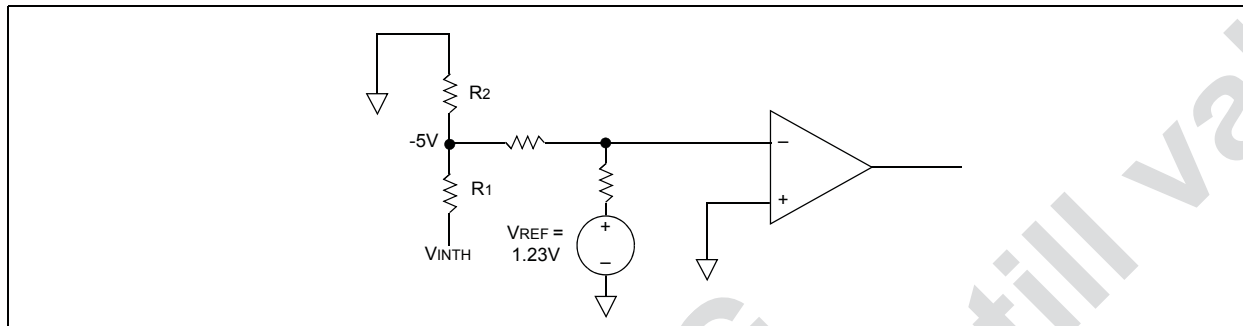

For the circuit shown in Figure 14, calculate R1 based on the desired  $\text{VIN}_x$  reset threshold voltage:

$$R1 = R2 \times \left( \frac{\text{VINTH}}{1.23\text{V}} - 1 \right) \quad (\text{EQ 3})$$

### Where:

$$R2 \leq 2.49\text{k}\Omega$$

$\text{VINTH}$  is the desired threshold voltage.

$\text{VTH}$  is the internal threshold voltage.

For  $-\text{VIN} = -12\text{V}$  nominal:

$$\text{VINTH} = -11.1\text{V},$$

$$\text{VTH} = -4.63\text{V},$$

$$R2 = 2.49\text{k}\Omega.$$

Using the equation given in (EQ 3), R1 can be calculated as:

$$R1 = 2.49\text{k}\Omega \times \left( \frac{-11.1\text{V}}{-4.63\text{V}} - 1 \right)$$

Therefore,  $R1 = 3.48\text{k}\Omega$

## Power-Supply Bypassing and Grounding

The AS1923 is powered from the IN2 supply input. All monitor inputs are immune to fast supply transients.

If higher immunity is required in noisy systems, connect  $0.1\mu\text{F}$  bypass capacitors from the IN2 input to ground (see Figure 15). Additional capacitance can be added to IN1, IN3, and IN4 to improve noise immunity at these inputs.

Figure 15. IN2 Additional Noise Immunity

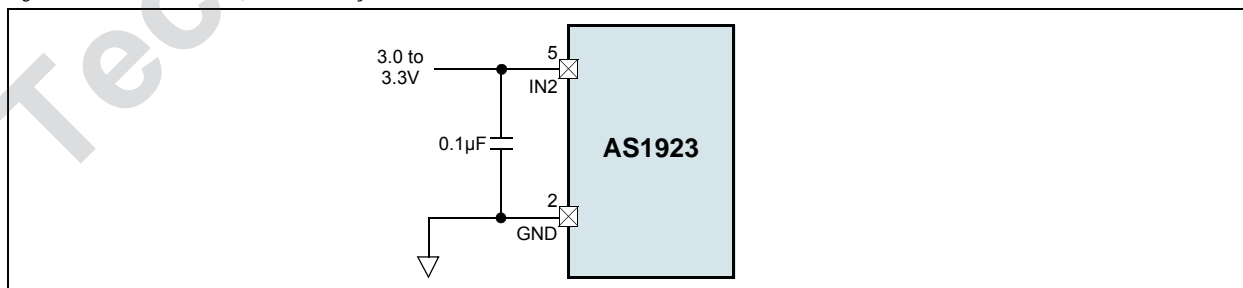

## 10 Package Drawings and Markings

Figure 16. 6-pin SOT23 Marking

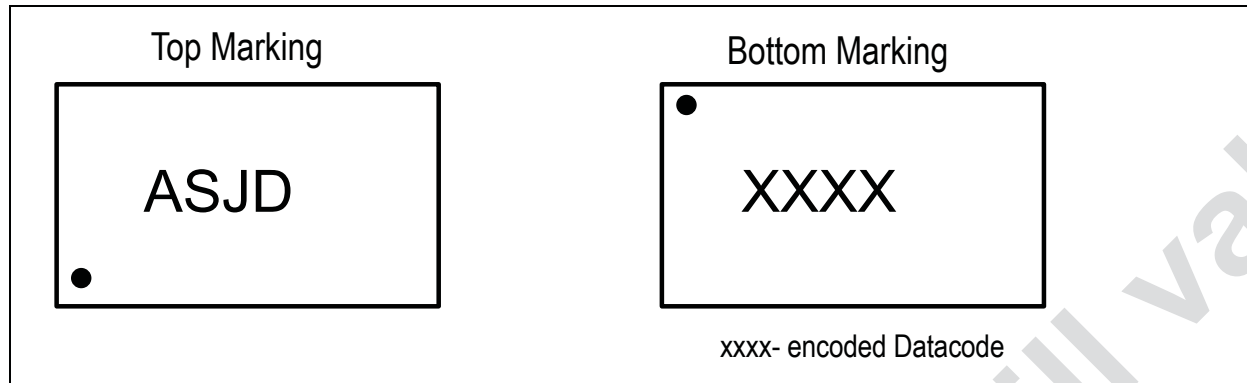
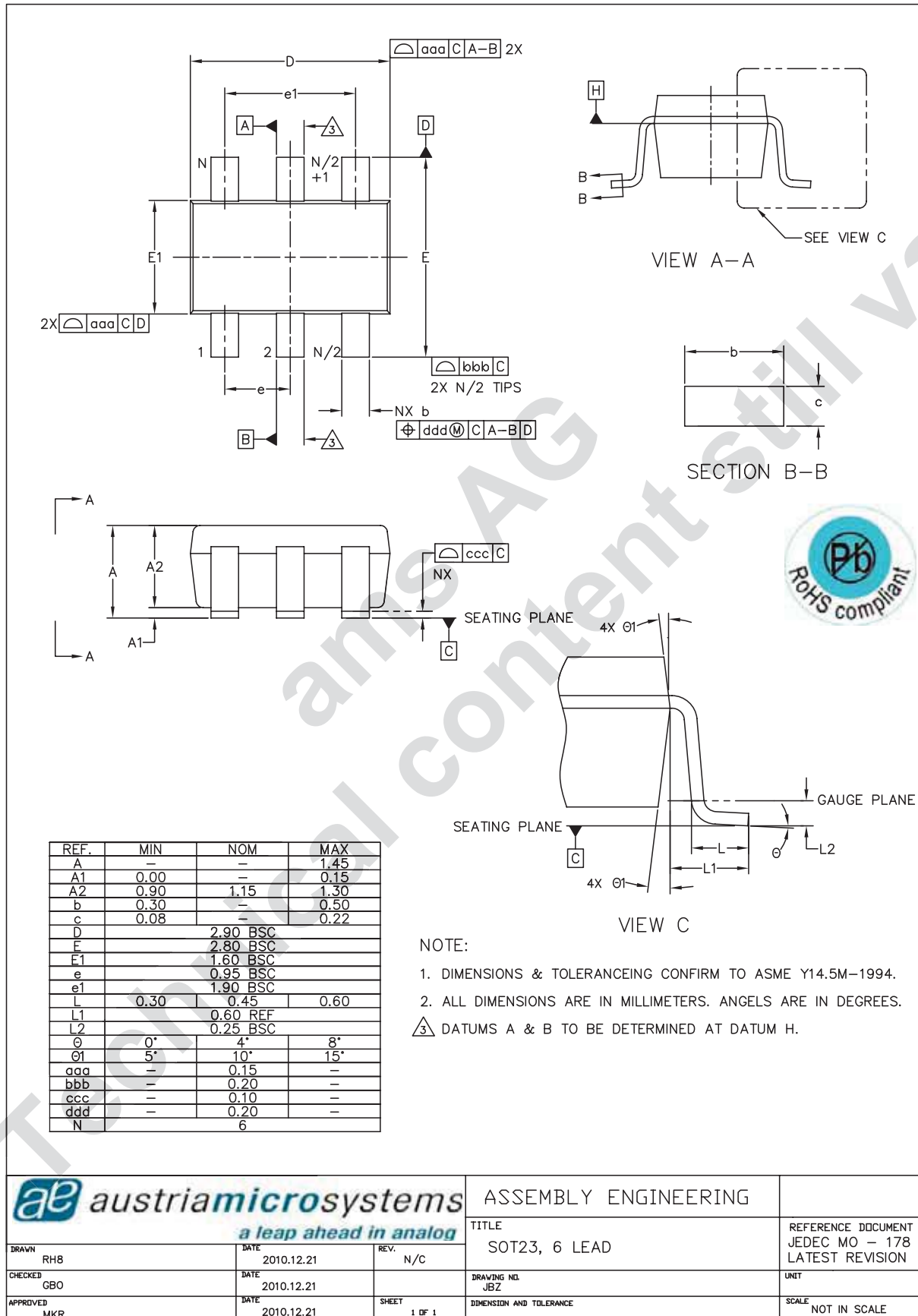

Figure 17. 6-pin SOT23 Package



## 11 Ordering Information

The device is available as the standard products listed in [Table 4](#).

Table 4. Ordering Information

Ordering Code	Marking	Description	Delivery Form	Package
AS1923A-BSTT-A	ASJD	Quad-Voltage Microprocessor Supervisory Circuit with Open Drain Output	Tape and Reel	6-pin SOT23
AS1923A-BSTT-C	ASJF	Quad-Voltage Microprocessor Supervisory Circuit with Open Drain Output	Tape and Reel	6-pin SOT23
AS1923A-BSTT-I	ASJP	Quad-Voltage Microprocessor Supervisory Circuit with Open Drain Output	Tape and Reel	6-pin SOT23
AS1923A-BSTT-K	ASJR	Quad-Voltage Microprocessor Supervisory Circuit with Open Drain Output	Tape and Reel	6-pin SOT23
AS1923A-BSTT-O	ASJV	Quad-Voltage Microprocessor Supervisory Circuit with Open Drain Output	Tape and Reel	6-pin SOT23
AS1923A-BSTT-x*	tbd	Quad-Voltage Microprocessor Supervisory Circuit with Open Drain Output	Tape and Reel	6-pin SOT23
AS1923B-BSTT-x*	tbd	Quad-Voltage Microprocessor Supervisory Circuit with Internal 10µA Current Source Pullup Output	Tape and Reel	6-pin SOT23

\*) on request

**Note:** All products are RoHS compliant.

Buy our products or get free samples online at ICdirect: <http://www.austriamicrosystems.com/ICdirect>

For further information and requests, please contact us <mailto:sales@austriamicrosystems.com> or find your local distributor at <http://www.austriamicrosystems.com/distributor>

These devices are available in factory-set input voltage thresholds. Choose the desired reset threshold suffix from [Table 5](#) and insert it instead of "x" in the part number.

Table 5. Variants Suffix Guide (x)

Variant (x)	Thresholds				Tolerance
	IN1	IN2	IN3	IN4	
A	5.0V	3.3V	2.5V	adjustable	10%
B <sup>1</sup>	5.0V	3.3V	2.5V <sup>2</sup>	adjustable	5%
C	5.0V	3.3V	1.8V	adjustable	10%
D <sup>1</sup>	5.0V	3.3V	1.8V <sup>2</sup>	adjustable	5%
E <sup>1</sup>	5.0V	3.0V	2.5V	adjustable	10%
F <sup>1</sup>	5.0V	3.0V	2.5V <sup>2</sup>	adjustable	5%
G <sup>1</sup>	5.0V	3.0V	1.8V	adjustable	10%
H <sup>1</sup>	5.0V	3.0V	1.8V <sup>2</sup>	adjustable	5%

Table 5. Variants Suffix Guide (x)

Variant (x)	Thresholds				Tolerance
	IN1	IN2	IN3	IN4	
I	5.0V	3.3V	2.5V <sup>2</sup>	1.8V	10%
J	5.0V	3.3V	2.5V <sup>2</sup>	1.8V <sup>2</sup>	5%
K	adjustable	3.3V	2.5V	adjustable	10%
L <sup>1</sup>	adjustable	3.3V	2.5V <sup>2</sup>	adjustable	5%
M <sup>1</sup>	5.0V	3.0V	adjustable	-5.0V	10%
N <sup>1</sup>	5.0V	3.0V	adjustable	-5.0V	5%
O	5.0V	3.3V	adjustable	-5.0V	10%
P	5.0V	3.3V	adjustable	-5.0V	5%

1. Available upon request
2. Specified for 10% tolerances

## Copyrights

Copyright © 1997-2011, austriamicrosystems AG, Tobelbaderstrasse 30, 8141 Unterpremstaetten, Austria-Europe. Trademarks Registered ©. All rights reserved. The material herein may not be reproduced, adapted, merged, translated, stored, or used without the prior written consent of the copyright owner.

All products and companies mentioned are trademarks or registered trademarks of their respective companies.

## Disclaimer

Devices sold by austriamicrosystems AG are covered by the warranty and patent indemnification provisions appearing in its Term of Sale. austriamicrosystems AG makes no warranty, express, statutory, implied, or by description regarding the information set forth herein or regarding the freedom of the described devices from patent infringement. austriamicrosystems AG reserves the right to change specifications and prices at any time and without notice. Therefore, prior to designing this product into a system, it is necessary to check with austriamicrosystems AG for current information. This product is intended for use in normal commercial applications. Applications requiring extended temperature range, unusual environmental requirements, or high reliability applications, such as military, medical life-support or life-sustaining equipment are specifically not recommended without additional processing by austriamicrosystems AG for each application. For shipments of less than 100 parts the manufacturing flow might show deviations from the standard production flow, such as test flow or test location.

The information furnished here by austriamicrosystems AG is believed to be correct and accurate. However, austriamicrosystems AG shall not be liable to recipient or any third party for any damages, including but not limited to personal injury, property damage, loss of profits, loss of use, interruption of business or indirect, special, incidental or consequential damages, of any kind, in connection with or arising out of the furnishing, performance or use of the technical data herein. No obligation or liability to recipient or any third party shall arise or flow out of austriamicrosystems AG rendering of technical or other services.



## Contact Information

### Headquarters

austriamicrosystems AG  
Tobelbaderstrasse 30  
A-8141 Unterpremstaetten, Austria

Tel: +43 (0) 3136 500 0  
Fax: +43 (0) 3136 525 01

For Sales Offices, Distributors and Representatives, please visit:

<http://www.austriamicrosystems.com/contact>

## Looking for pricing, stock, or lifecycle information?

Click below to explore more details on WIN SOURCE:

- ⊖ [View AS1923A-BSTT-I on WIN SOURCE](#)
- ⊖ [OSRAM Opto Semiconductors Inc. Information](#)

## Optimize Your Supply Chain with WIN SOURCE Solutions

- ✓ Global Sourcing Solution
- ✓ Obsolete Management
- ✓ Cost Control Management
- ✓ Shortage Management
- ✓ Alternative Solution
- ✓ Excess Inventory Management