



THE DATASHEET OF
09670029078





Pushing Performance

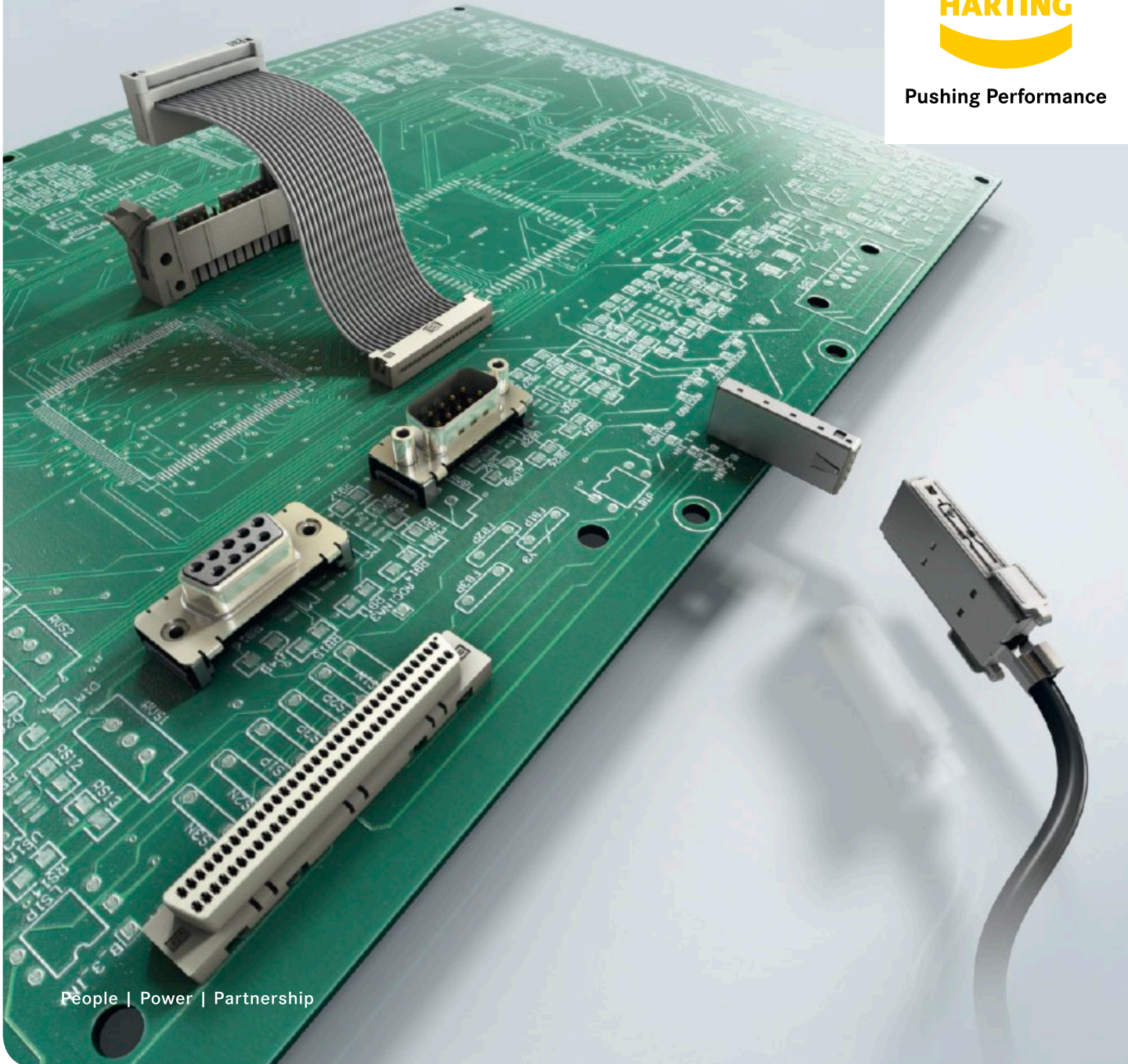

People | Power | Partnership

HARTING

Interface Connectors

Transforming customer wishes into concrete solutions



The HARTING Technology Group is skilled in the fields of electrical, electronic and optical connection, transmission and networking, as well as in manufacturing, mechatronics and software creation. The Group uses these skills to develop customized solutions and products such as connectors for energy and data transmission applications including, for example, mechanical engineering, rail technology, wind energy plants, factory automation and the telecommunications sector. In addition, HARTING also produces electro-magnetic components for the automobile industry and offers solutions in the field of Enclosures and Shop Systems.

The HARTING Group currently comprises 37 subsidiary companies and worldwide distributors employing a total of more than 3,500 staff.



HARTING Subsidiary company



HARTING Representatives



We aspire to top performance.

Connectors ensure functionality. As core elements of electrical and optical wiring, connection and infrastructure technologies, they are essential in enabling the modular construction of devices, machines and systems across a very wide range of industrial applications. Their reliability is a crucial factor guaranteeing smooth functioning in the manufacturing area, in telecommunications, applications in medical technology – in fact, connectors are at work in virtually every conceivable application area. Thanks to the consistent further development of our technologies, customers enjoy investment security and benefit from durable, long term functionality.

Always at hand, wherever our customers may be.

Increasing industrialization is creating growing markets characterized by widely diverging demands and requirements. The search for perfection, increasingly efficient processes and reliable technologies is a common factor in all sectors across the globe.

HARTING is providing these technologies – in Europe, America and Asia. The **HARTING** professionals at our international subsidiaries engage in close, partnership based interaction with our customers, right from the very early product development phases, in order to realize customer demands and requirements in the best possible manner.

Our people on location form the interface to the centrally coordinated development and production departments. In this way, our customers can rely on consistently high, superior product quality – worldwide.

Our claim: Pushing Performance.

HARTING provides more than optimally attuned components. In order to serve our customers with the best possible solutions, **HARTING** is able to contribute a great deal more and play a closely integrative role in the value creation process.

From ready assembled cables through to control racks or ready-to-go control desks: Our aim is to generate the maximum benefits for our customers – without compromise!

Quality creates reliability – and warrants trust.

The **HARTING** brand stands for superior quality and reliability – worldwide. The standards we set are the result of consistent, stringent quality management that is subject to regular certifications and audits.

EN ISO 9001, the EU Eco-Audit and ISO 14001:2004 are key elements here. We take a proactive stance to new requirements, which is why **HARTING** ranks among the first companies worldwide to have obtained the new IRIS quality certificate for rail vehicles.



HARTING technology creates added value for customers. Technologies by HARTING are at work worldwide. HARTING's presence stands for smoothly functioning systems, powered by intelligent connectors, smart infrastructure solutions and mature network systems. In the course of many years of close, trust-based cooperation with its customers, the HARTING Technology Group has advanced to one of the worldwide leading specialists for connector technology. Extending beyond the basic functionalities demanded, we offer individual customers specific and innovative solutions. These tailored solutions deliver sustained effects, provide investment security and enable customers to achieve strong added value.

Opting for HARTING opens up an innovative, complex world of concepts and ideas.

In order to develop connectivity and network solutions serving an exceptionally wide range of connector applications and task scopes in a professional and cost optimized manner, HARTING not only commands the full array of conventional tools and basic technologies. Over and beyond these capabilities, HARTING is constantly harnessing and refining its broad base of knowledge and experience to create new solutions that ensure continuity at the same time. In securing this know-how lead, HARTING draws on a wealth of sources from both in-house research and the world of applications alike.

Salient examples of these sources of innovative knowledge include microstructure technologies, 3D design and construction technology, as well as high temperature

or ultrahigh frequency applications that are finding use in telecommunications or automation networks, in the automotive industry, or in industrial sensor and actuator applications, RFID and wireless technologies, in addition to packaging and housing made of plastics, aluminum or stainless steel.

HARTING solutions extend across technology boundaries.

Drawing on the comprehensive resources of the group's technology pool, HARTING devises practical solutions for its customers. Whether this involves industrial networks for manufacturing automation, or hybrid interface solutions for wireless telecommunication infrastructures, 3D circuit carriers with microstructures, or cable assemblies for high-temperature applications in the automotive industry – HARTING technologies offer far more than components, and represent mature, comprehensive solutions attuned to individual customer requirements and wishes. The range covers ready-to-use cable configurations, completely assembled backplanes and board system carriers, as well as fully wired and tested control panels.

In order to ensure the future proof design of RF- and EMC-compatible interface solutions, the central HARTING laboratory (certified to EN 45001) provides simulation tools, as well as experimental, testing and diagnostics facilities all the way through to scanning electron microscopes. In the selection of materials and processes, lifecycle and environmental aspects play a key role, in addition to product and process capability considerations.



HARTING knowledge is practical know-how generating synergy effects.

HARTING commands decades of experience with regard to the applications conditions of connectors in telecommunications, computer and network technologies and medical technologies, as well as industrial automation technologies, such as the mechanical engineering and plant engineering areas, in addition to the power generation industry or the transportation sector. **HARTING** is highly conversant with the specific application areas in all of these technology fields.

The key focus is on applications in every solution approach. In this context, uncompromising, superior quality is our hallmark. Every new solution found will invariably flow back into the **HARTING** technology pool, thereby enriching our resources. And every new solution we go on to create will draw on this wealth of resources in order to optimize each and every individual solution. In this way, **HARTING** is synergy in action.

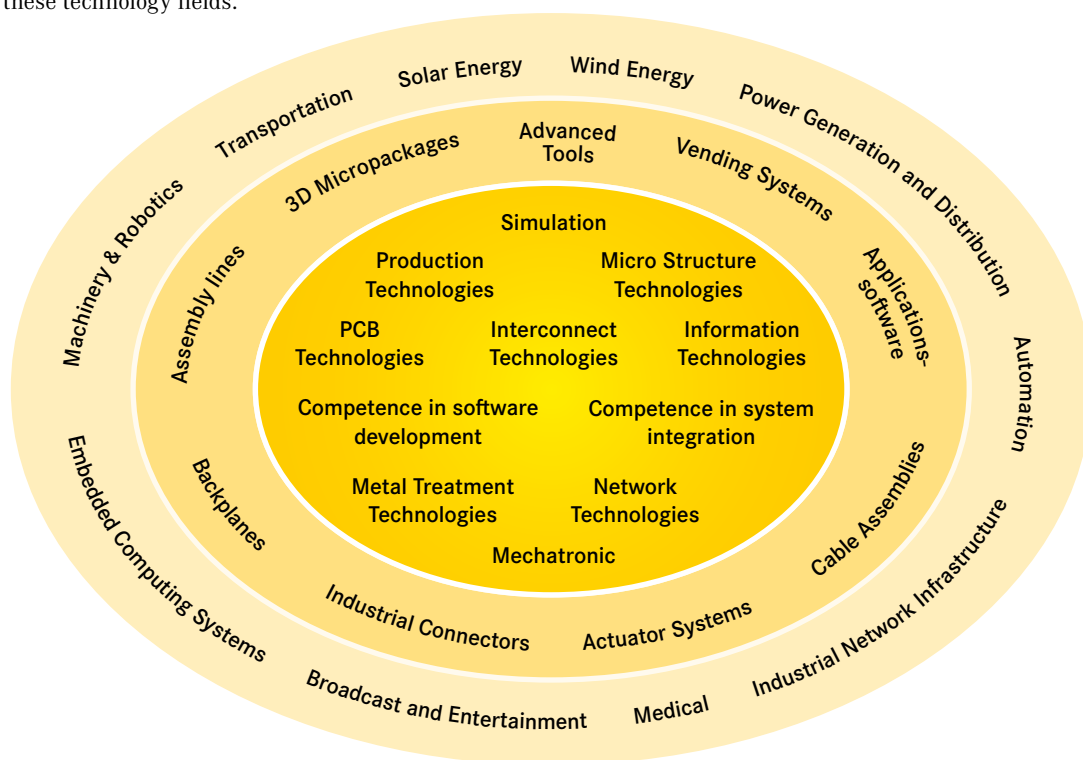

The next generation of D-Sub SMT with straight surface mounts

HARTING has announced the launch of a range of straight D-Sub SMT connectors to complement its established angled product portfolio. Meeting HARTING's high quality standards, this new series of connectors offers an optimized design that

ensures a high level of dependability and optimal processing characteristics. It enables surface mounting thus simplifying PCB assembly significantly and broadening its range of applications.

100% co-planarity is achieved through the use of stamped contacts and the specially designed insulator. This robust solution is capable of withstanding all normal handling processes. Two variants are available – a connector for standard applications with flat, solderable pads to withstand plug-in and withdrawal forces and a variant for more demanding requirements with a solderable assembly pin in addition to the flat pads.

The black insulator, which is designed for improved camera detection, includes two positioning pegs for improved pick and place process reliability. Also included is a large removable cover for a 10 mm vacuum pipette. All connectors are available with 9 to 37 contacts and are supplied with the option of M3 and 4-40 UNC threaded inserts and fixed female screw locks. Performance level 2 and 3 are standard. PL1 can be delivered upon request. In addition to 140-piece reels suitable for automatic assembly, these products can be delivered in other special packaging depending on customer requirements.

Details you can find in chapter 21.



D-Sub SMT straight

HARTING *har-link*[®]: Now also with solder buckets

HARTING is expanding its space-saving, *har-link*[®] metric product range with a version with solder buckets. Up to now, connectors were supplied on the cable side only with an insulation displacement termination. The new *har-link*[®] with solder buckets now enables the customer to assemble prototypes for test purposes for easy and rapid assembly. With these new contacts, the multitude of different cables available on the market with wire gauges ranging from AWG 30 to AWG 24 can be connected.

HARTING's modular and compact *har-link*[®] interface connectors with 2.0 mm spacing can transmit data of up to 2 GBit/s per twisted conductor. Also equipped with a special screening concept, *har-link*[®] reliably delivers optimum functionality in areas affected electromagnetically. *har-link*[®] is manufactured in accordance with IEC 61076-4-107 and is a compact, robust cable connector which guarantees excellent data transmission to the PCB in high frequency networks and telecommunication applications.

Details you can find in chapter 00.

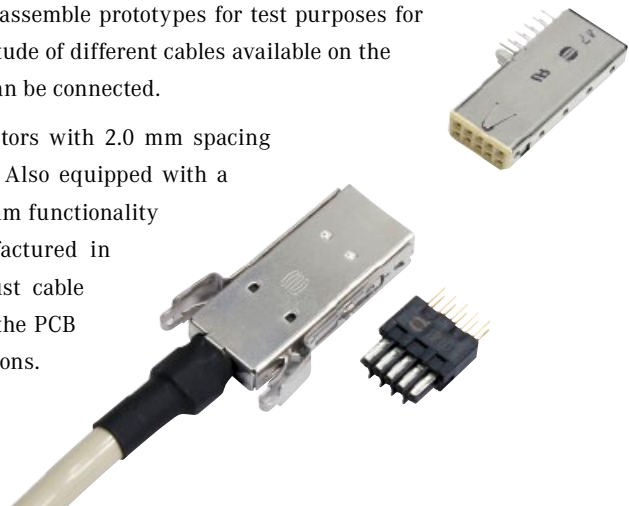

har-link[®] with solder buckets

Interface connectors

Chapter

harlink® Modular metric high speed connectors
IEC 61076-4-107, 2.0 mm [0.079"] pitch

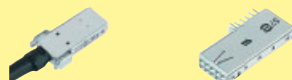

00

harmik® Miniature D connectors, IEC 61076-3-100,
IEC 61076-3-101, 1.27 mm [0.050"] pitch



01

D-Sub – Standard subminiature D connectors
CECC 75301-802



02

D-Sub – High Density subminiature D connectors



03

D-Sub – Mixed subminiature D connectors
DIN 41652 T1



04

D-Sub – Filter subminiature D connectors
IEC 1000, 2.54 mm [0.100"] pitch



05

D-Sub – Waterproof subminiature D IP 67 connectors
IP 67 housings



06

D-Sub – Housing range for subminiature D connectors
Comprehensive shielded and unshielded range



07

D-Sub – Accessories for subminiature D connectors

08

SEK Insulation Displacement Connector system (IDC)
IEC 60603-13, 2.54 mm [0.100"] pitch



09

Press-in technology
Press-in board connectors



20

Surface Mount Technology (SMT)
board connectors



21

Surface Mount Compatible (SMC)
board connectors



22

Tooling for press-in technology



30

Tooling for crimp technology



31

Tooling for IDC technology



32

Cables and cable assemblies



40

List of part numbers

80

Company addresses

90

The **HARTING eCatalogue** is an electronic catalogue with a part configuration and 3D components library.

har-link

Here you can choose a connector according to your requirements. Afterwards you are able to send your inquiry directly to a HARTING sales partner.

The drawings to every single part are available in PDF-format.

The parts are downloadable in 2D-format (DXF) and 3D-format (IGES, STEP).

The 3D-models can be viewed with a VRML-viewer.

You can find the **HARTING eCatalogue** at www.HARTING.com.

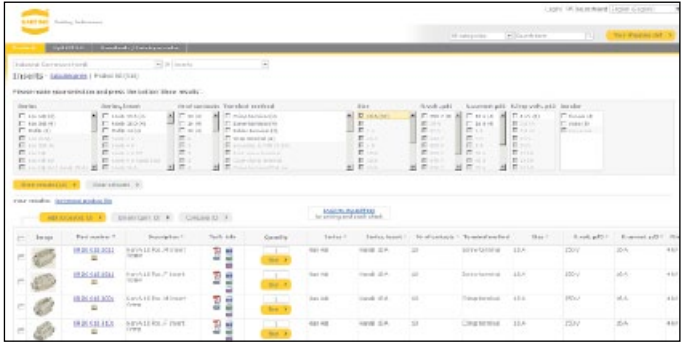

Product selection

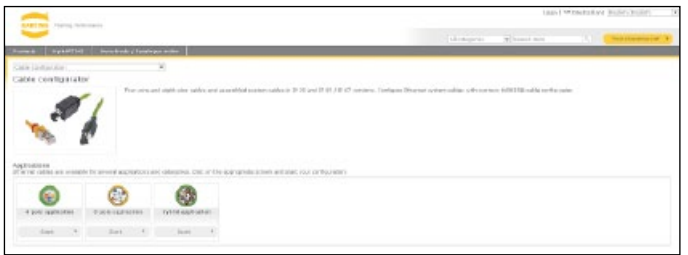

Product configuration

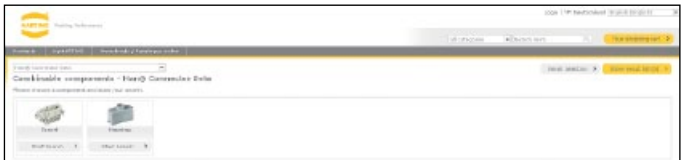

Product combination



Product overview

Product samples: Fast-track delivery to your desk, free of charge

The new free express sample service in the HARTING eCatalogue allows customers to order samples immediately, easily and completely free of charge. A broad selection from the device connectivity product portfolio is now available. If a product is unavailable, the system offers alternative products with similar features that can be requested at a mouse click.

The free samples are shipped within 24 hours at no cost to you. This service enables tremendous flexibility, especially in the design phase of projects.

General approvals:



UL-listed E 10 2079 (M)



Interface connectors are in conformity with the **Directive 2002/95/EG** EC Directive on the Restriction and Use of Certain Hazardous Substances in Electrical and Electronic Devices **RoHS**

har-link® Modular metric high speed connectors, 2.0 mm pitch

Page

har-link® connector system – general information

00.04

Technical characteristics

00.06

Male and female connectors

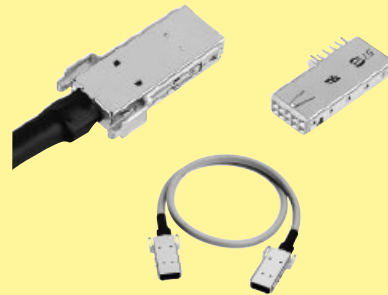

00.07

Accessories and cable assemblies

00.08

har-link

The **harlink®** connector system of HARTING complies with the requirements of IEC 61076-4-107 and is a compact and robust pcb-to-cable interface with excellent data transmission properties for high-speed networking and telecommunications.

All dimensions of the **harlink®** connector are in accordance with IEC 917 and IEEE P 1301 requirements, which allows for easy implementation into both metric and inch-based systems. In addition, **harlink®** supports hot plugging as required by modern bus systems such as CompactPCI, S-bus and VME.

harlink® allows data transmission up to 2 Gbit/s per pair and is therefore perfectly suited for modern transmission protocols such as Low Voltage Differential Signals (see Fig. 1). The design of the **harlink®** connector allows differential pairs to be placed horizontally (parallel to the pcb), thus reducing the skew at high frequencies and considering high signal integrity.

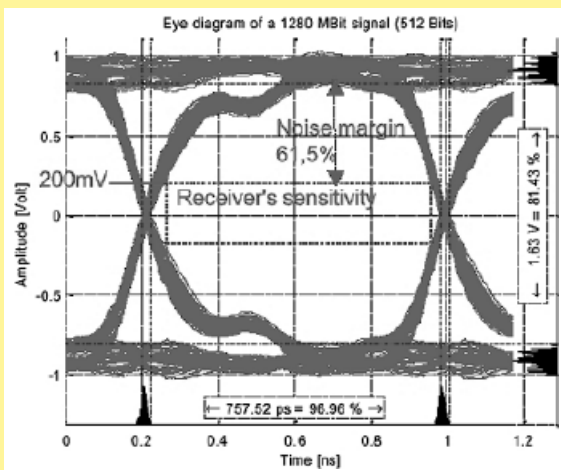

Fig. 1: Eye diagram of a 1280 MBit signal (512 Bits)

The metal shells of the **harlink®** connector are a guarantee for its superior performance in the EMI-polluted environment (see Fig. 2).



Fig. 2: 360° screened-can construction with locking levers

To reach a screening attenuation of more than 50 dB up to 1 GHz, HARTING offers brackets covering each connector in conjunction with a gasket, which is compressed between the bracket and the front panel (see Fig. 3).

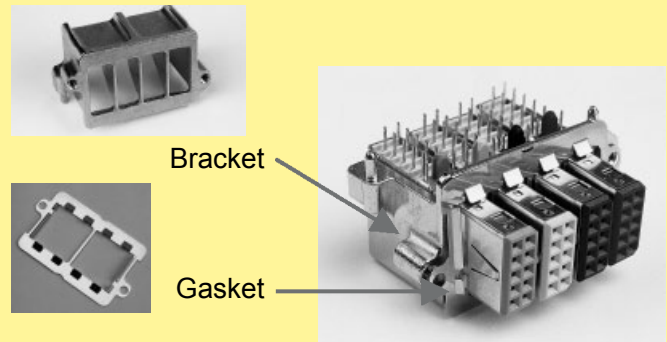

Fig. 3: 4 cavities bracket and gasket

Once plugged, the mated pair shows excellent mating safety. Due to the locking levers on both sides of the male connector, the connection withstands a pulling force of up to 80 N (see Fig. 2).

The high temperature resistant material of the **harlink®** female connector body supports the safe reflow soldering process. For easy identification of female modules, six different colours are available (see Fig. 4).

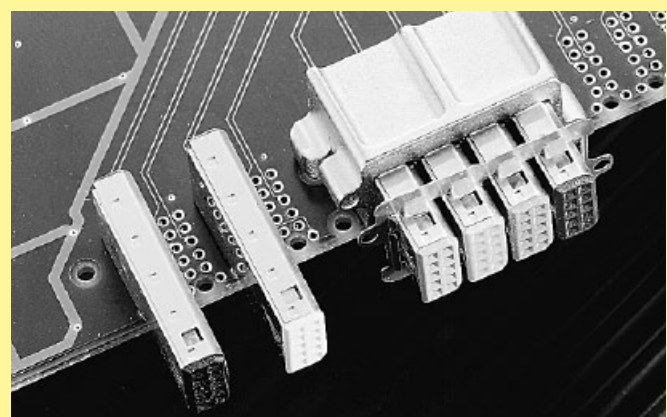
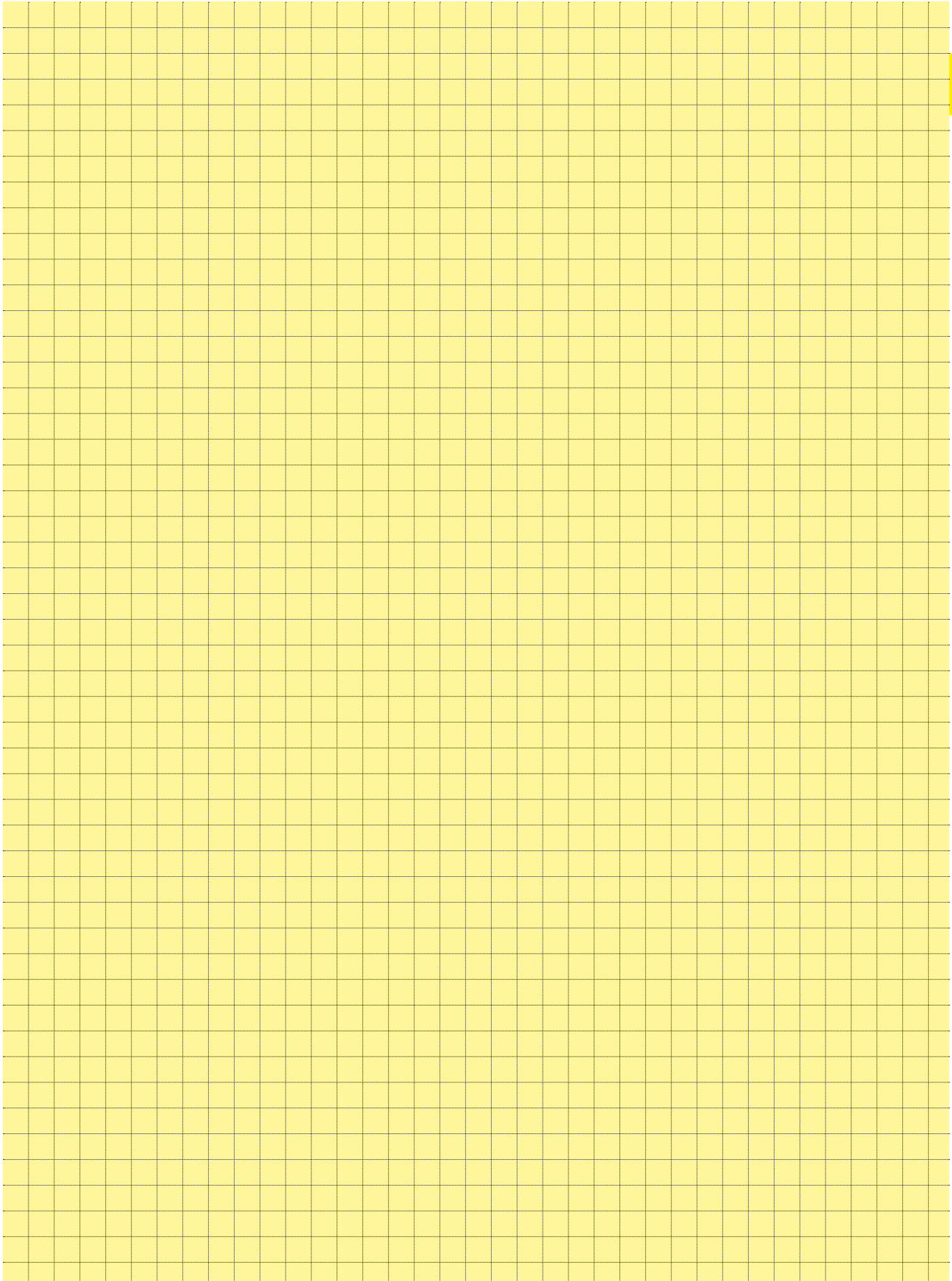
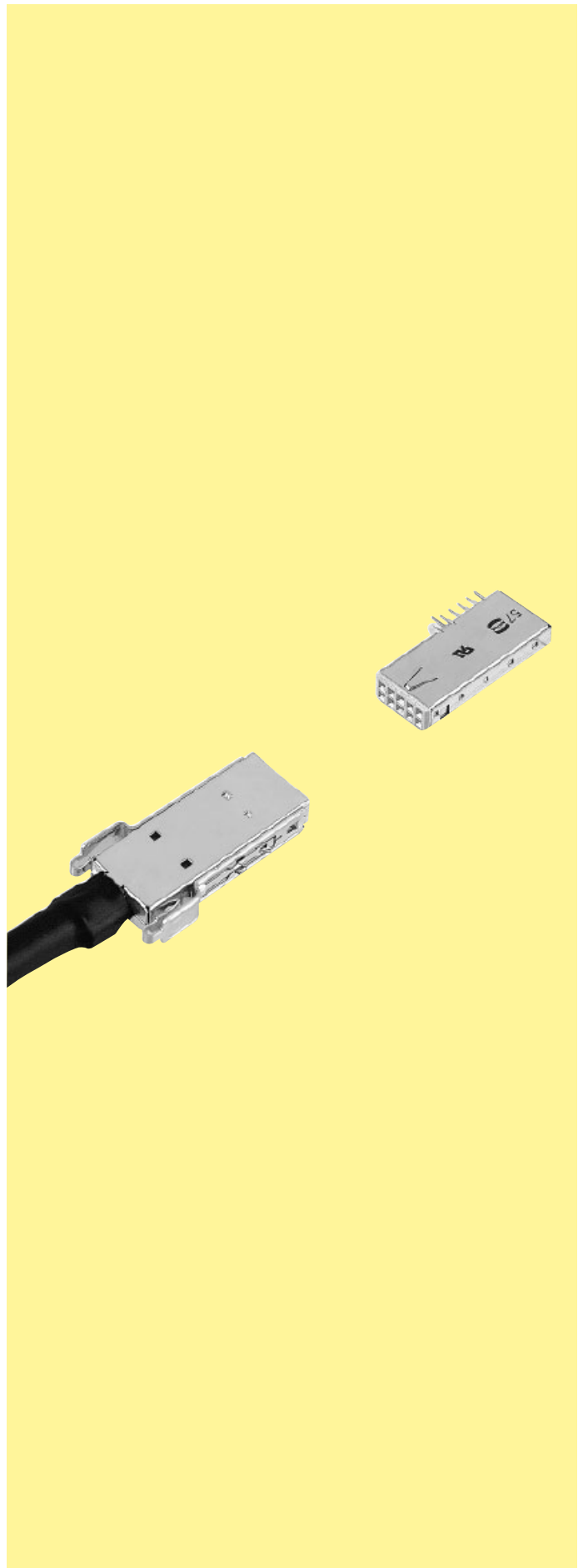

Fig. 4: Female modules

In addition to single connectors, HARTING provides cable assemblies with unshielded twisted pairs or with shielded twisted pairs for high speed applications such as IEEE 1355. A crimping tool range for terminating the male **harlink®** connectors is available.



Number of contacts	10
Approvals	IEC 61076-4-107 UL recognized: E102079
Contact pitch Connector pitch	2 mm 6 mm
Working current	1.5 A at 70 °C
Test voltage $U_{r.m.s.}$	750 V
Contact resistance Insulation resistance	$\leq 35 \text{ m}\Omega$ $\geq 10^{10} \Omega$
Temperature range during reflow soldering	-55 °C ... +125 °C female: max. + 260 °C for 60 s
Mating cycles	250, performance level 2
Terminations	Solder buckets (male), AWG 24-30, outer insulation \varnothing $5.33 \pm 0.25 \text{ mm}$ Solder pins for $\varnothing 0.6 \text{ mm}$ min. (female)
Insertion force Withdrawal force	10 N max. / module 2 N min. / module (without locking levers)
Latching system	Locking levers
Materials	
Mouldings	Male connector: Polyester, UL 94-V0 Female connector: High temperature plastic material, UL 94-V0
Contacts	Copper alloy
Shells	Male connector: Stainless steel Female connector: Silver nickel
Contact surface Contact zone	Selectively plated according to performance level



Male connectors, straight
Female connectors, angled

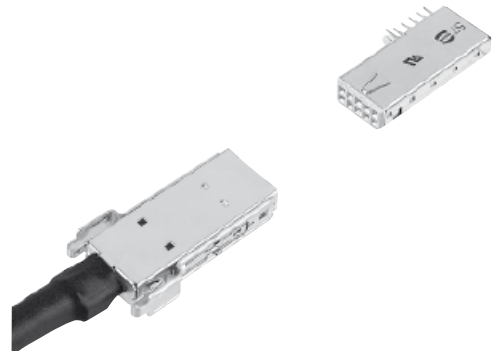

Identification	No. of contacts	Colour	Part No.
Male connector with solder buckets	10	Black	27 11 122 2001
Female connector with solder pins	10	Beige (standard)	27 21 121 8000
	10	Red	27 21 121 8002
	10	Yellow	27 21 121 8004
	10	Green	27 21 121 8005
	10	Blue	27 21 121 8006
	10	Black	27 21 121 8010

Male connector
(delivered in piece parts)

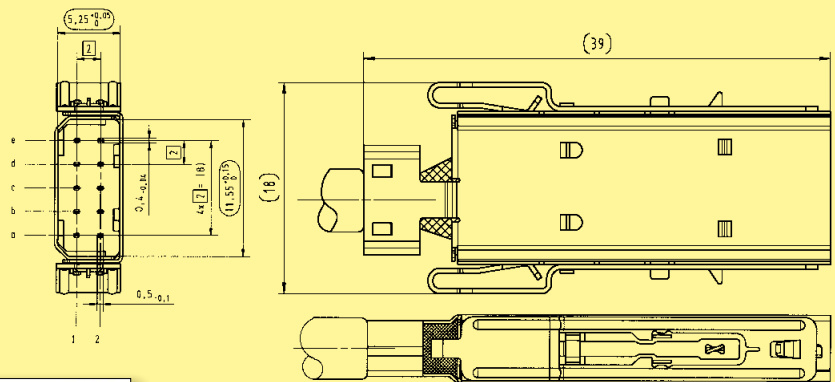

Manuals for the *har-link*® cable free connector assemblies are available in our online catalogue *HARKIS*® or on demand at your local HARTING representative.

Female connector

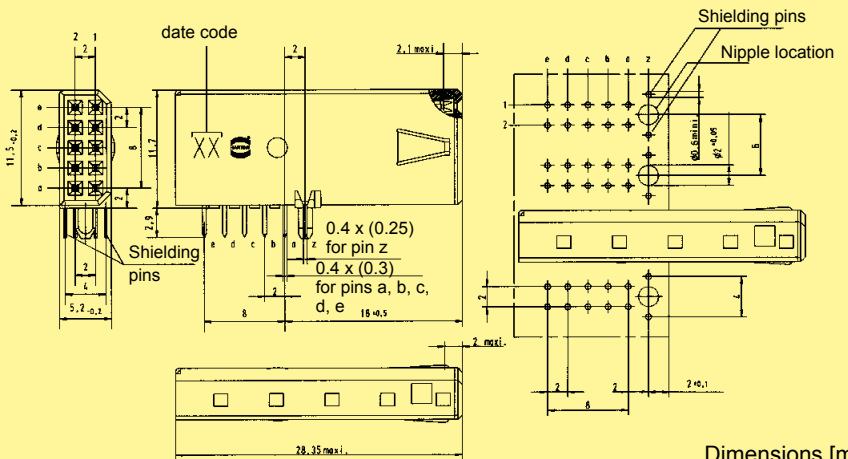

Dimensions [mm]

Accessories and cable assemblies

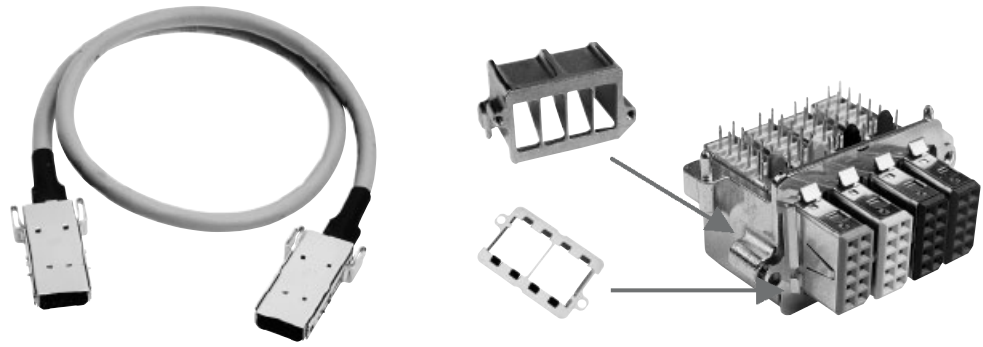

Identification Part No. Drawing Dimensions in mm

Bracket
with four cavities

27 71 040 0001

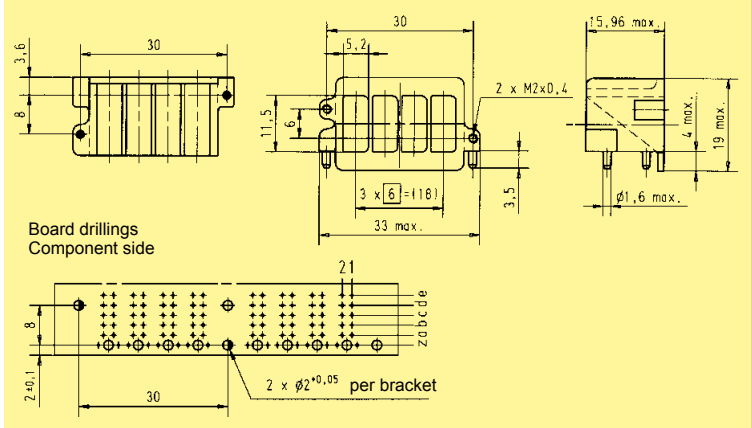

Gasket
with four cavities

27 71 040 0002

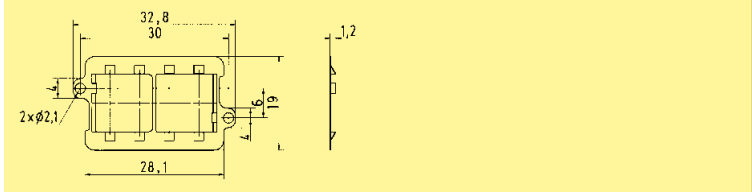

Standard har-link® cable assembly
Cable: 5 twisted pairs, AWG 28, shielded, PVC
Wiring: 1:1

Length: L = 0.5 m
L = 1.0 m
L = 2.0 m

33 27 243 0500 001
33 27 243 1000 002
33 27 243 2000 003

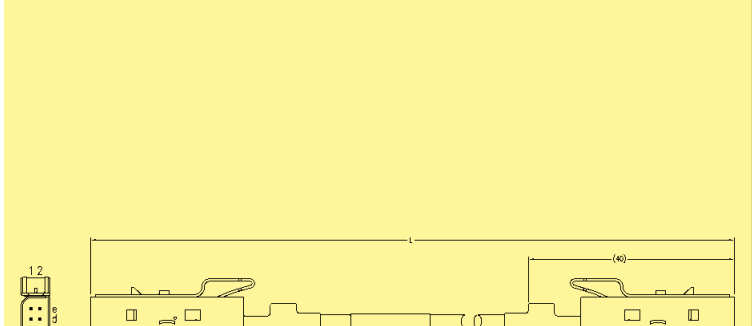

High end har-link® cable assembly
Cable: 5 twisted pairs, AWG 30, double shielded, PVC
Wiring: 1:1

Length: L = 0.5 m
L = 1.0 m
L = 2.0 m

33 27 243 0500 006
33 27 243 1000 007
33 27 243 2000 008

Cable: 5 twisted pairs, AWG 30, double shielded, PVC
Wiring: acc. to IEEE 1355

Length: L = 0.5 m
L = 1.0 m
L = 2.0 m

33 27 243 0500 015
33 27 243 1000 016
33 27 243 2000 017

IEEE 1355 wiring

Connector 1	Connector 2	Connector 1	Connector 2
2-e	1-a	1-c	1-c
1-e	2-a	2-b	1-d
2-d	1-b	1-b	2-d
1-d	2-b	2-a	1-e
2-c	2-c	1-a	2-e

harmik[®] Miniature D connectors, 1.27 mm pitch

Page

I/O connectors **01.02**

Pin and socket

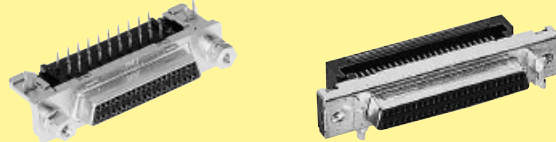

- Technical characteristics **01.03**
- Connectors with straight solder pins **01.04**
- Connectors with right angled solder pins **01.06**
- Connectors with IDC flat cable termination **01.08**
- Connectors with IDC discrete wire termination **01.09**

Bellows



- Technical characteristics **01.10**
- Connectors with straight solder pins **01.11**
- Connectors with right angled solder pins **01.13**
- Connectors with IDC discrete wire termination **01.14**

Hoods



- Technical characteristics **01.15**
- Hoods for pin and socket male connectors **01.16**
- Hoods for bellows male connectors **01.18**

Accessories **01.20**

Intra cabinet connectors **01.21**

Pin and socket

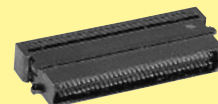

- Technical characteristics **01.22**
- Connectors with straight solder pins **01.23**
- Connectors with IDC flat cable termination **01.24**

Cables and cable assemblies



see chapter 40 **01**
01

for economical and reliable connections

harmik

A comprehensive range of high density interface connectors based on two mating design concepts:

- Blade and fork contact in the Pin/Socket range.
- Leaf contact in the Bellows range.

Available in a various number of contacts with options for secure locking of mated connectors in accordance with the following international standards:

- Small Computer System Interface
SCSI-2
SCSI-2 wide
SCSI-3
- Intelligent Peripheral Interface
IPI
- High Performance Peripheral Interface
HIPPI
- High Speed Serial Interface
HSSI
- Media Independent Interface
MII
- Bi-directional Parallel Interface
IEEE – 1284-C
- EIA – TIA
232-E
- IEC
61076-3-100
for bellows connectors
- IEC
61076-3-101
for pin and socket connectors

UL recognised

For customer specific applications we can design and manufacture solutions to match your requirement.

Sales department
HARTING components



Certified according to EN ISO 9001 in design/development, production, installation and servicing

Bellows
with leaf contact design

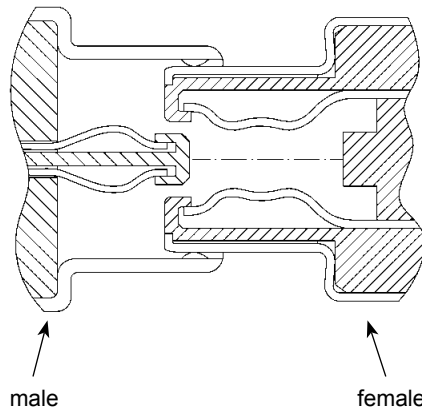

Pin and socket
with blade and fork contact design

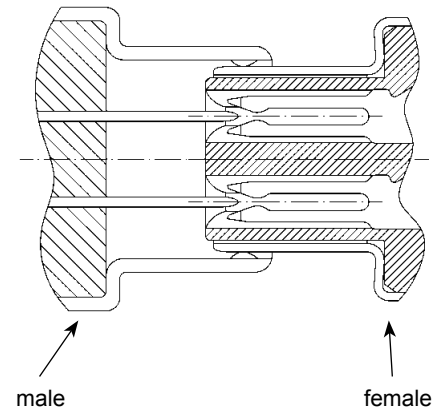

I/O connectors

Number of contacts	20, 26, 50, 68, 100
Pitch	1.27 mm
Working current	1 A
Working voltage	240 V ~
Test voltage $U_{r.m.s.}$	750 V
Contact resistance	$\leq 30 \text{ m}\Omega$
Insulation resistance	$\geq 10^3 \text{ M}\Omega$
Temperature range	-55 °C ... + 105 °C
Terminations	
Solder pins	Straight for pcb holes min. $\varnothing 0.74 \text{ mm}$ Angled 90° for pcb holes min. $\varnothing 0.74 \text{ mm}$
Insulation displacement	Discrete wire AWG 28 to AWG 30 max. section: 0.089 mm^2 min. section: 0.050 mm^2 Insulation \varnothing min. 0.50 mm \varnothing max. 0.90 mm Flat cable AWG 30 pitch 0.635 mm
Materials	
Moulding	Thermoplastic resin glass-fibre filled UL 94-V0
Contacts	Copper alloy
Contact surface	
Contact zone	S4 = $0.76 \mu\text{m}$ (30 μinch) Au or PdNi equivalent
Metal shell	Die cast zamac or stamped steel, nickel-plated

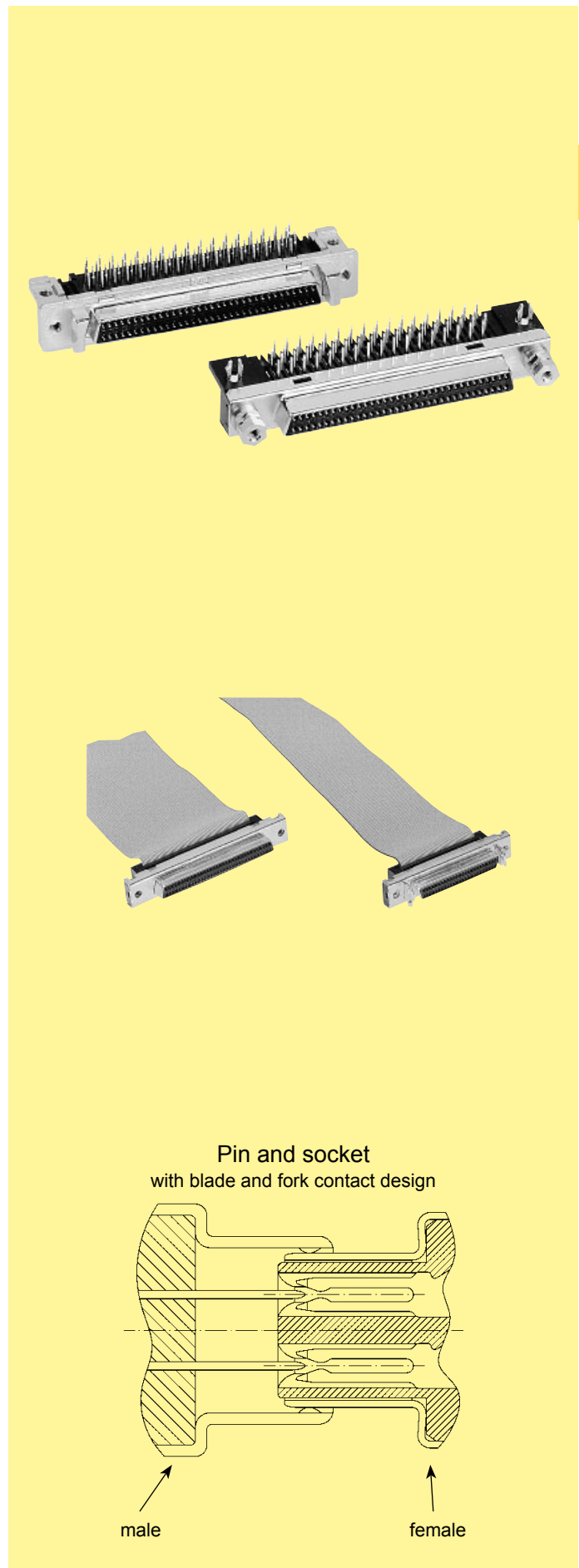

Number of contacts

20–68



Female connectors, straight

Identification	No. of contacts	Part No.
Female connectors with straight solder pins	20	60 01 020 5102
	26	60 01 026 5102
	50	60 01 050 5102
	68	60 01 068 5102

Dimensions

	a	b _{±0.1}	c	e	f	g	h
20	33.40	27.43	15.60	9 x 1.27 = 11.43	23.24	23.70	27.45
26	37.21	31.24	19.41	12 x 1.27 = 15.24	27.05	27.50	31.25
50	52.45	46.48	34.65	24 x 1.27 = 30.48	42.29	42.80	46.50
68	63.88	57.91	46.08	33 x 1.27 = 41.91	53.72	54.20	57.90

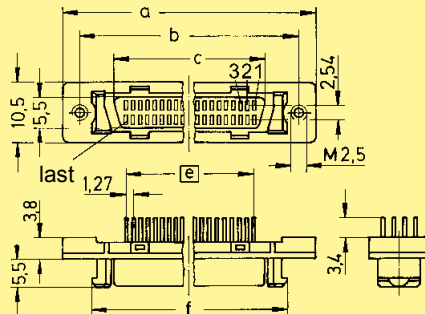

Board drillings

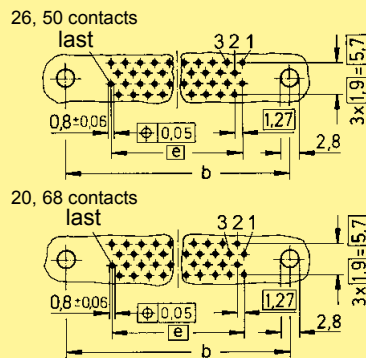

Panel cut out

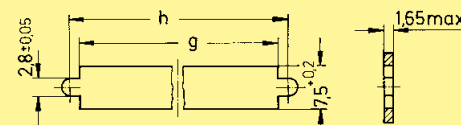

Dimensions in mm

Number of contacts

68

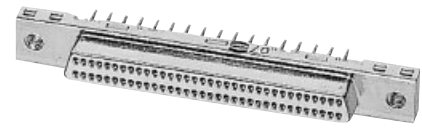

Female connectors, straight

har-mik

Identification	No. of contacts	Part No.
Female connector with straight solder pins	68	60 02 068 5120

Dimensions

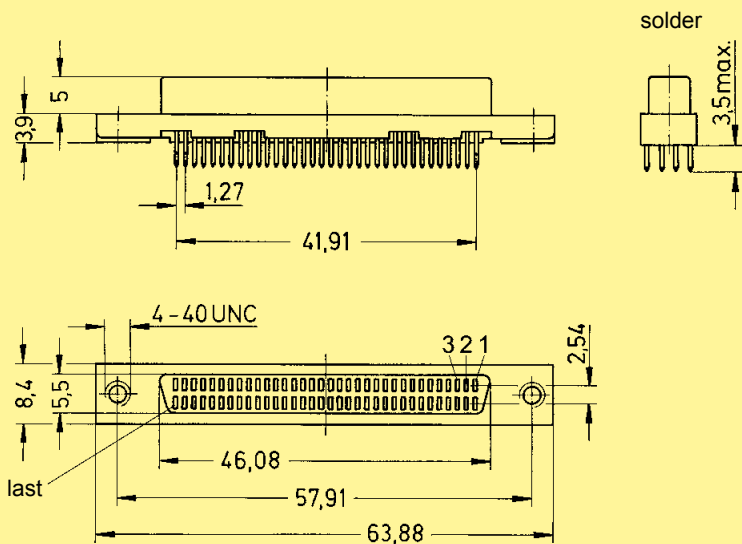

Board drillings
(Components side)

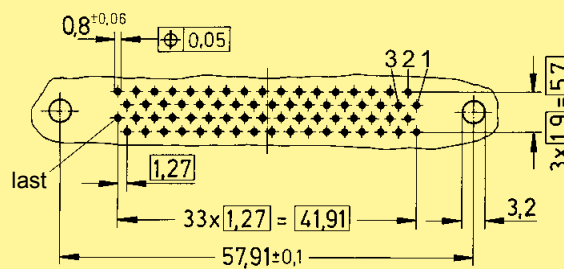

Dimensions in mm

Number of contacts

20–68

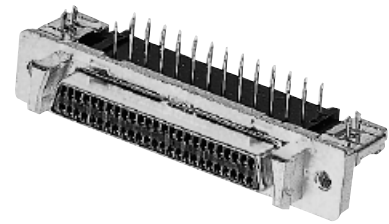

Female connectors, angled

Identification	No. of contacts	Part No.
Female connectors with angled solder pins	20	60 01 020 51 ...
	26	60 01 026 51 ...
	50	60 01 050 51 ...
	68	60 01 068 51 ...

Panel fixing	Board fixing	
M 2.5	M 2.5	32
M 2.5	Board lock	40

Dimensions

	a	b _{±0.1}	c	e	f	g	h
20	33.40	27.40	15.60	9 x 1.27 = 11.43	23.24	23.70	27.45
26	37.21	31.24	19.41	12 x 1.27 = 15.24	27.05	27.50	31.25
50	52.45	46.45	34.65	24 x 1.27 = 30.48	42.29	42.80	46.50
68	63.88	57.88	46.08	33 x 1.27 = 41.91	53.72	54.20	57.90

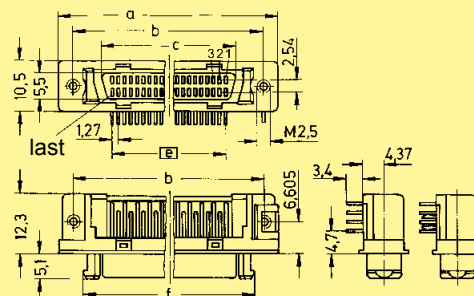

without board lock with board lock

Board drillings

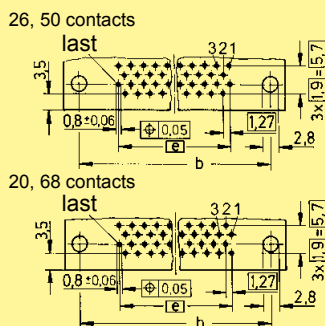

Panel cut out

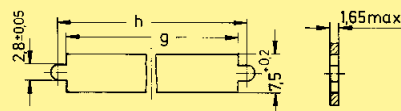

Dimensions in mm

Number of contacts

68-100

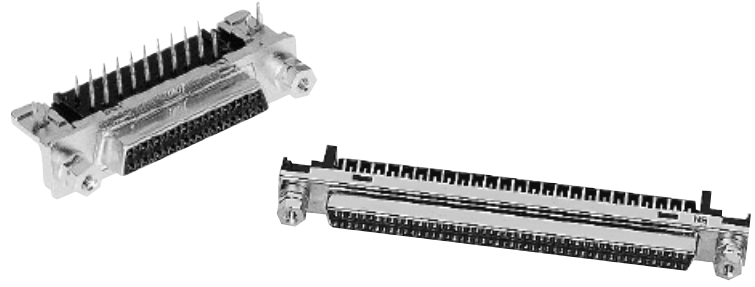

Female connectors, angled

har-mik

Identification	No. of contacts	Part No.
Female connectors with angled solder pins	68	60 02 068 51 . . .
	100	60 02 100 51 . . .
With female screw lock	41	
Without female screw lock	50	

Dimensions

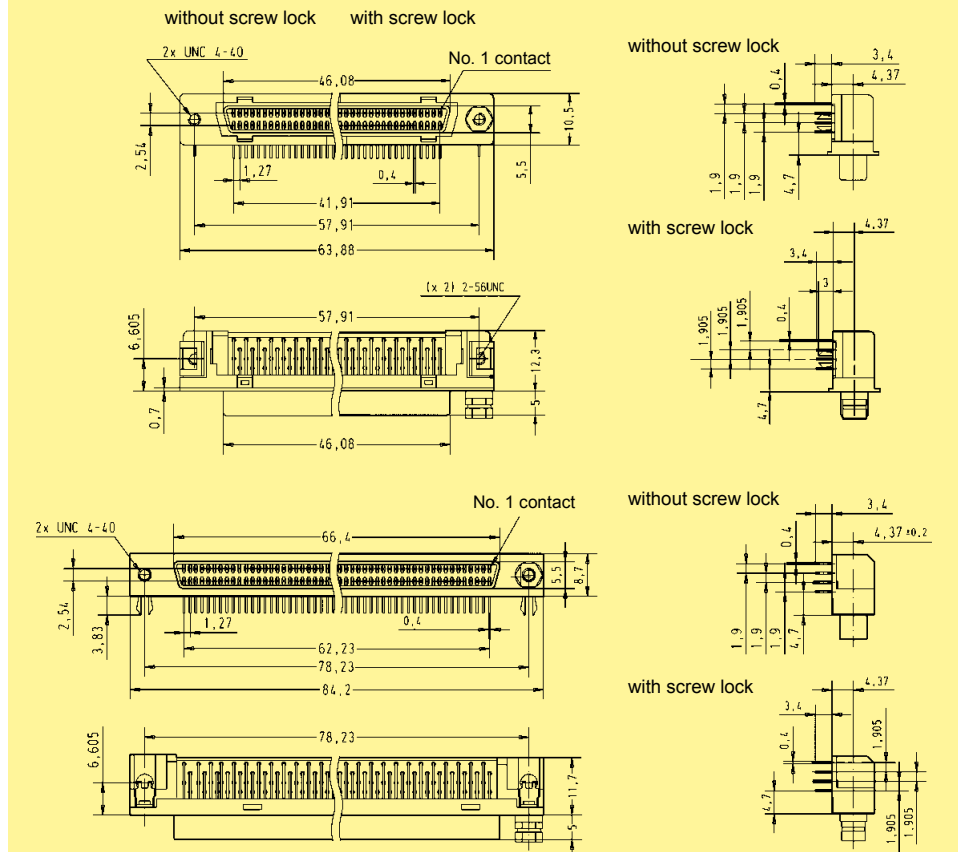

Board drillings (Components side)

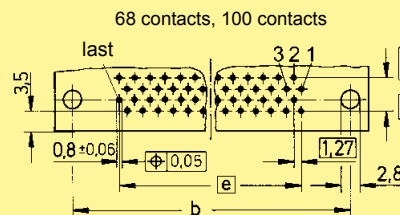

	a ₁	b	c	e
68	54.22	57.91	4.4	33 x 1.27 = 41.91
100	74.53	78.23	2.8	49 x 1.27 = 62.23

Panel cut out

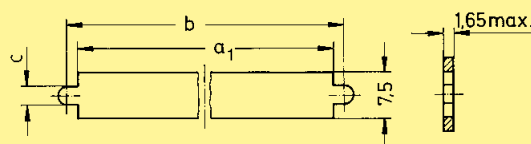

Dimensions in mm

Number of contacts

50-68

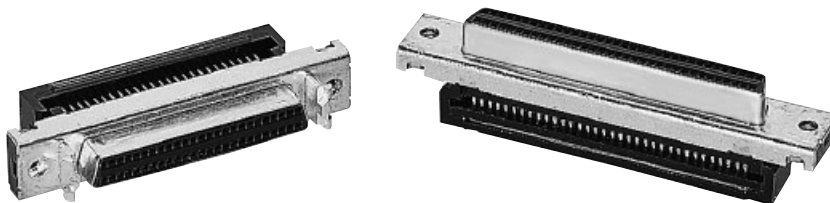

Female connectors for IDC flat cable, straight

Identification	No. of contacts	Part No.	
		with latch system	with screw lock system
Female panel connectors with insulation displacement termination for IDC flat cable pitch 0.635 mm AWG 30	50	60 04 050 5343	60 04 050 5344
	68	60 04 068 5343	60 04 068 5344

Dimensions for connectors with latch system

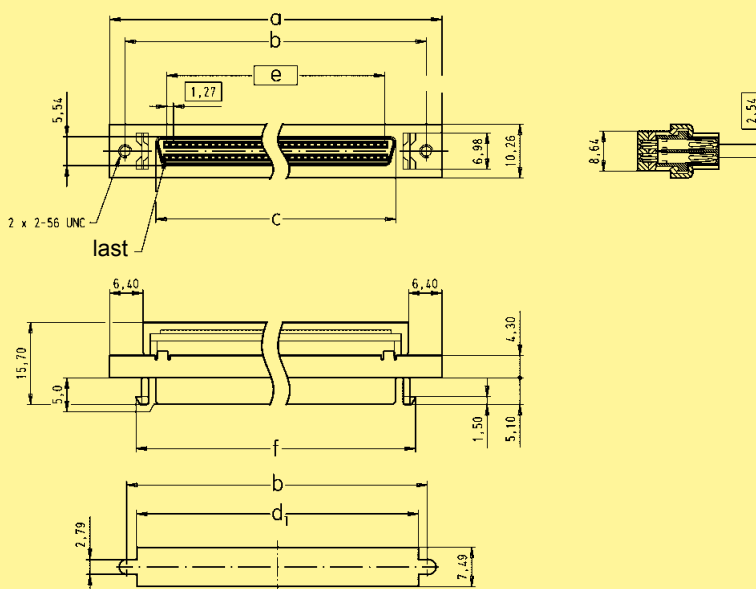

Panel cut out

	a	b	c	d ₁	d ₂	e	f
50	52.45	46.48	34.70	42.80	42.30	30.48	42.30
68	63.88	57.91	46.13	54.23	53.72	41.91	53.72

Dimensions for connectors with screw lock system

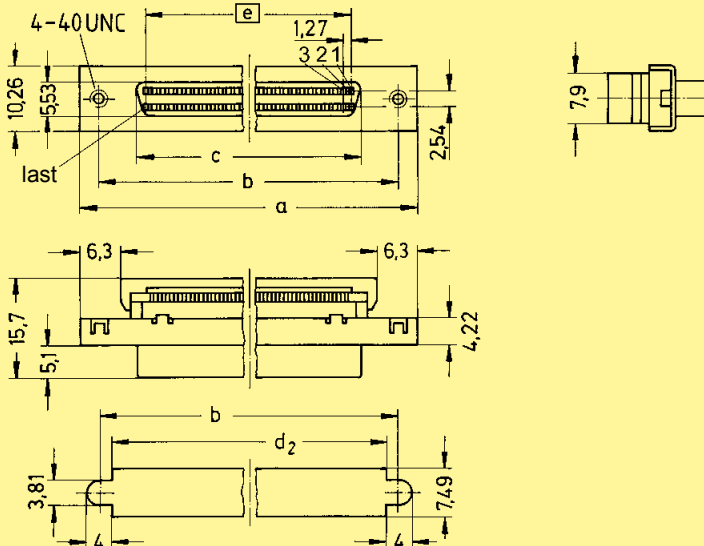

Panel cut out

Dimensions in mm

Number of contacts

20–100

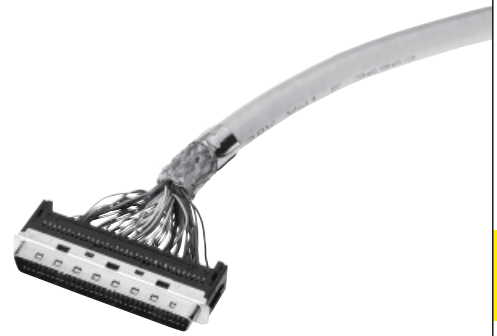

Male connectors for IDC discrete wire, straight

har-mik

Identification	No. of contacts	Part No.	
Male connectors with insulation displacement termination for discrete wire AWG 28/30	20	60 03 020 52	<p>A manual for the <i>har-mik®</i> connector and cable assembly is available in our online catalogue <i>HARKIS®</i> or on demand at your local HARTING representative.</p> 
	26	60 03 026 52	
	50	60 03 050 52	
	68	60 03 068 52	
	100	60 03 100 52	
Insulation diameter (mm)	00		
	05		
	10		
	15		
	20		

Available sizes

	Part No.	Ø	20	26	50	68	100
Male	60 03 ... 5200	0.50–0.65	●	●	●		
	60 03 ... 5205	0.50–0.75				●	
	60 03 ... 5210	0.65–0.80	●		●		●
	60 03 ... 5215	0.75–0.90				●	
	60 03 ... 5220	0.80–0.88	●	●	●		

● = Available sizes

Dimensions

Comb cover
(delivered with connectors)

20 / 26 / 50 / 100 contacts

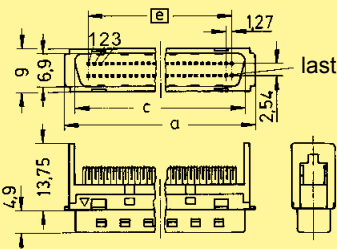

68 contacts

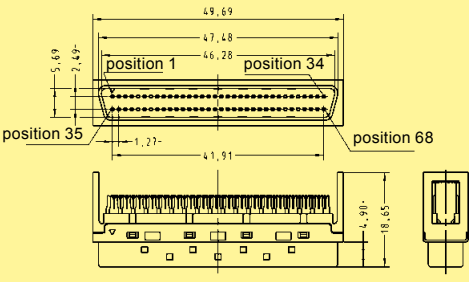

	a	c	d	e
20	21.25	17.00	16.75	11.43
26	25.06	20.81	20.56	15.24
50	40.30	36.05	35.80	30.48
100	72.05	67.80	67.55	62.23

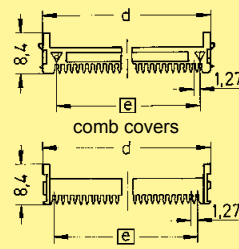
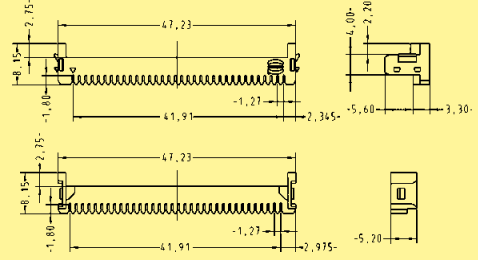
Dimensions in mm

harmik

Number of contacts	14, 20, 26, 36, 50, 68
Pitch	1.27 mm
Working current	1 A
Working voltage	240 V ~
Test voltage $U_{r.m.s.}$	750 V (standard) 500 V (light weight)
Contact resistance	≤ 40 m Ω (standard) ≤ 45 m Ω (light weight)
Insulation resistance	$\geq 10^3$ M Ω
Temperature range during SMC reflow soldering	-55 °C ... +105 °C max. 240 °C for 60 s
Terminations	
Solder pins	Straight for pcb holes min. \varnothing 0.74 mm Angled 90° for pcb holes min. \varnothing 0.74 mm (wave soldering) min. \varnothing 0.62 mm (light weight)
Insulation displacement	AWG 28 to AWG 30 max. section: 0.089 mm ² min. section: 0.050 mm ² Insulation \varnothing min. 0.50 mm \varnothing max. 0.90 mm
Materials	
Moulding	Thermoplastic resin glass-fibre filled UL 94-V0
Contacts	Copper alloy
Contact surface	
Contact zone	S4 = 0.76 μ m (30 μ inch) Au or PdNi equivalent
Metal shell	Die cast zamac or stamped steel, nickel-plated

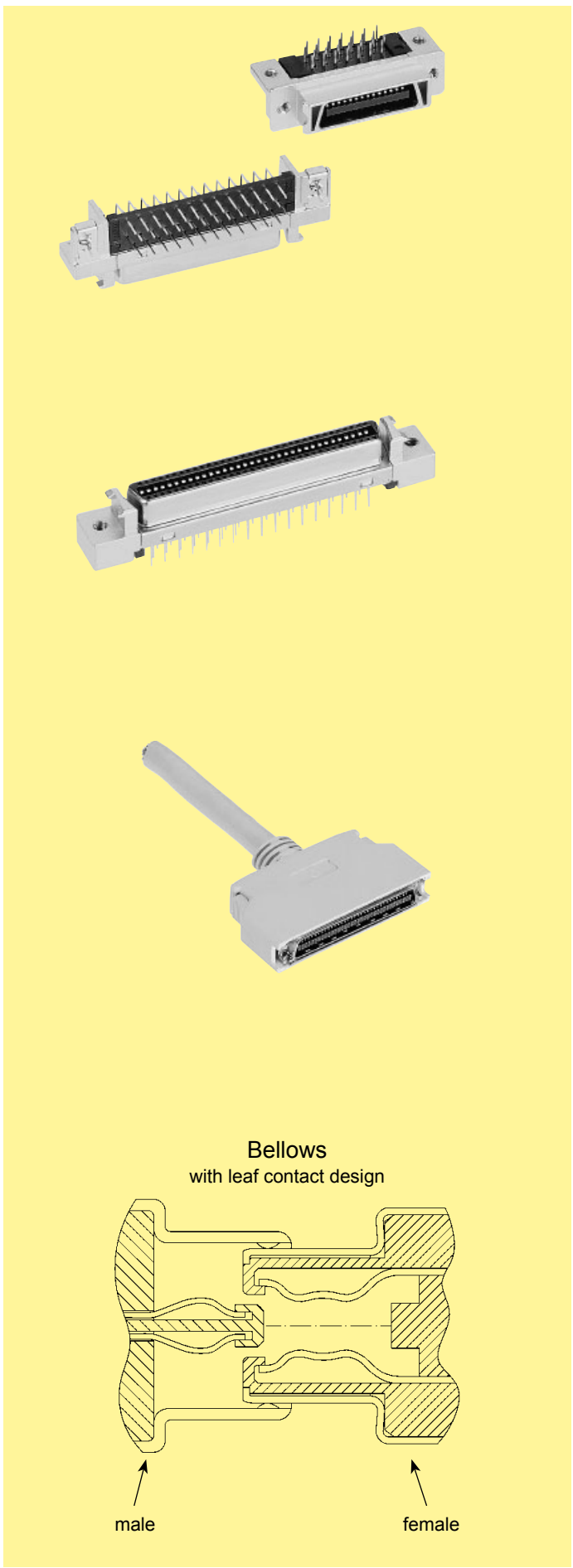

Number of contacts

26–68

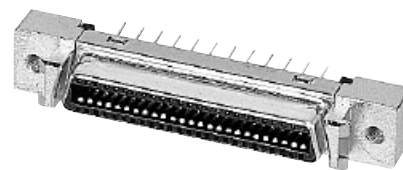

Female connectors, straight

harmik

Identification	No. of contacts	Part No.
Female connectors with straight solder pins	26	60 11 026 5102
	36	60 11 036 5102
	50	60 11 050 5102
	68	60 11 068 5102

Dimensions

Board drillings

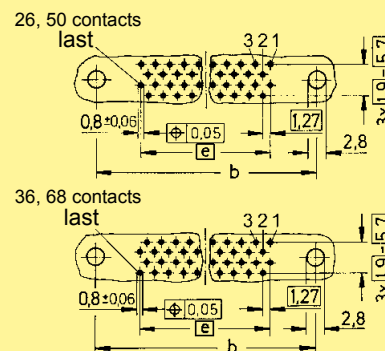
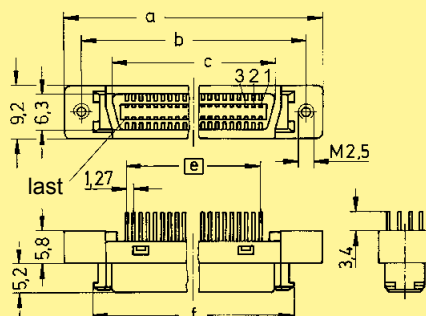

	a	b ± 0.1	c	e	f	g	h
26	37.16	31.26	20.26	12 x 1.27 = 15.24	27.11	27.50	31.25
36	43.51	37.61	26.61	17 x 1.27 = 21.59	33.46	33.90	37.60
50	52.40	46.50	35.50	24 x 1.27 = 30.48	42.35	42.80	46.50
68	63.83	57.93	46.93	33 x 1.27 = 41.91	53.78	54.20	57.90

Panel cut out

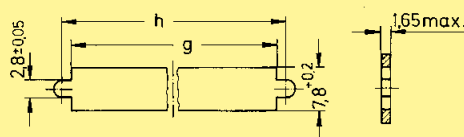

Dimensions in mm

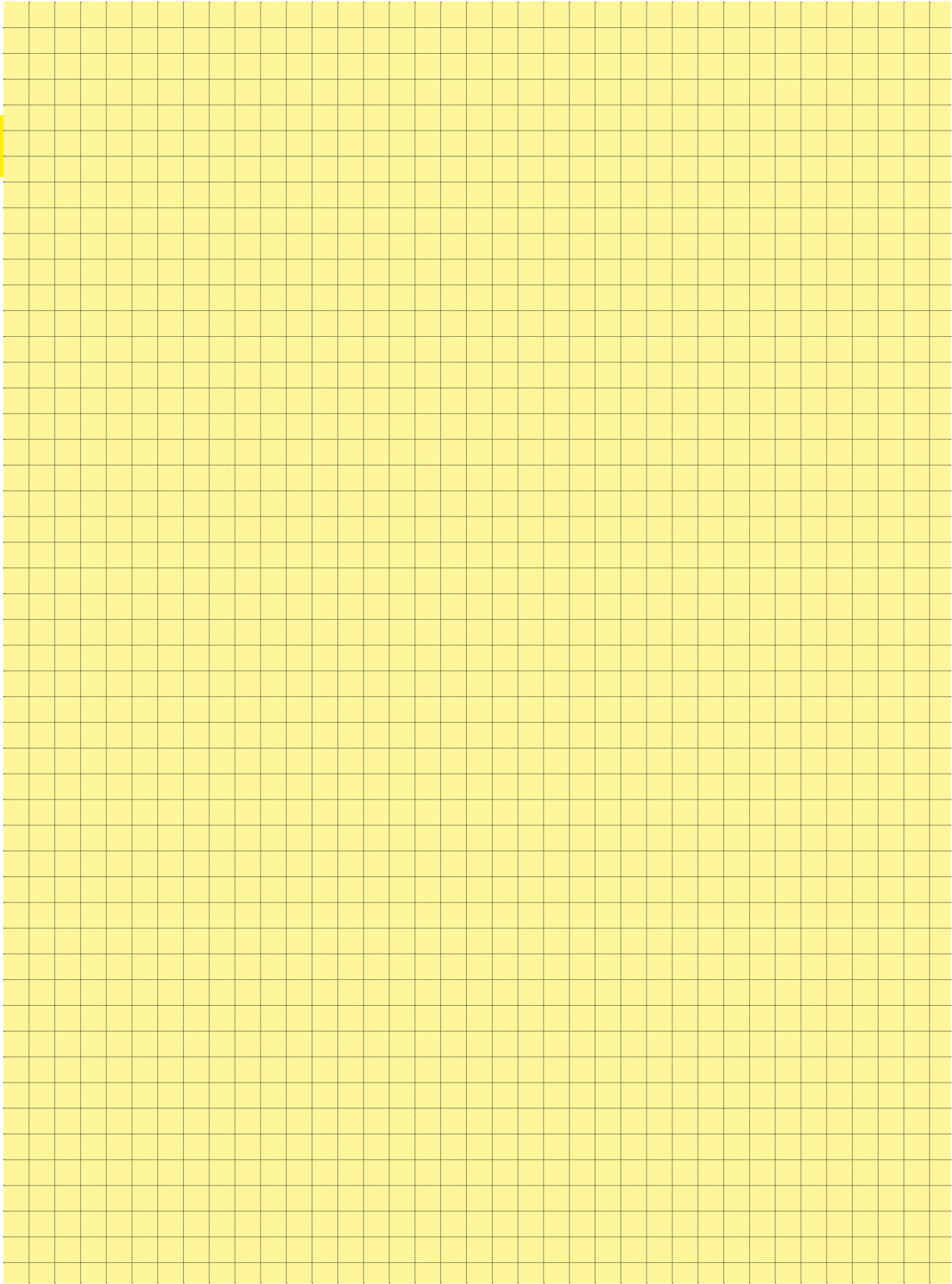

Number of contacts

14-68

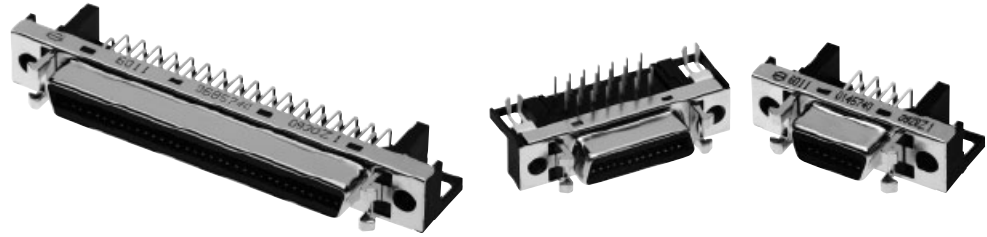

Light weight female connectors, angled

Identification	No. of contacts	for one reel (300 pieces)		Part No.	standard tray packaging
Light weight female connectors with angled solder pins, for pick and place assembly	14	60 11 014 57	.. 710	60 11 014 57	..
	20	60 11 020 57	.. 710	60 11 020 57	..
	26	60 11 026 57	.. 710	60 11 026 57	..
	36	60 11 036 57	.. 710	60 11 036 57	..
	50	60 11 050 57	.. 710	60 11 050 57	..
	68	60 11 068 57	.. 710	60 11 068 57	..
Without board lock	32				
With board lock	40				

Dimensions

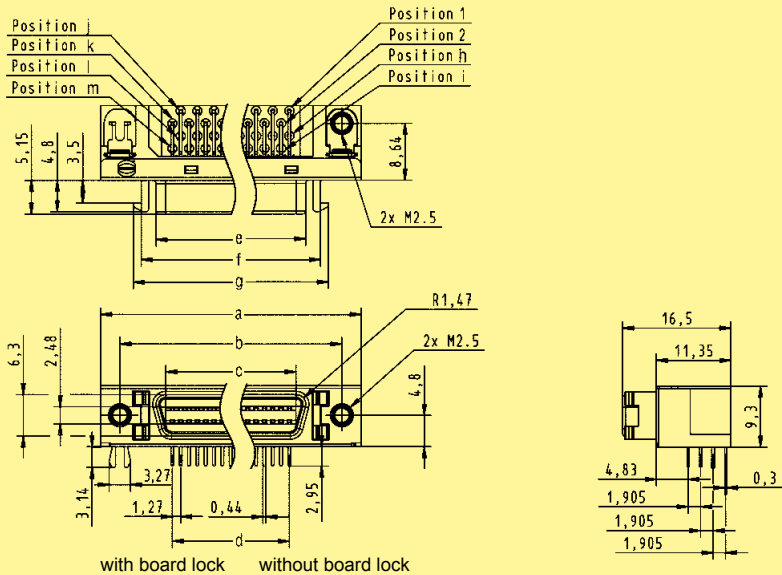

	a	b	c	d	e	f	g	h	i	j	k	l	m	n
14	29.54	23.64	9.62	7.62	12.62	17.14	19.54	8	9	7	6	14	13	44.0
20	33.35	27.45	13.43	11.43	16.43	20.95	23.35	11	12	9	10	19	20	56.5
26	37.16	31.26	17.24	15.24	20.24	24.76	27.16	14	15	13	12	26	25	56.0
36	43.51	37.61	23.59	21.59	26.59	31.11	33.51	19	20	17	18	35	36	56.0
50	52.40	46.50	32.48	30.48	35.48	40.00	42.40	26	27	25	24	50	49	72.5
68	63.83	57.93	43.91	41.91	46.91	51.43	53.83	35	36	33	34	67	68	88.5

Board drillings
(Components side)

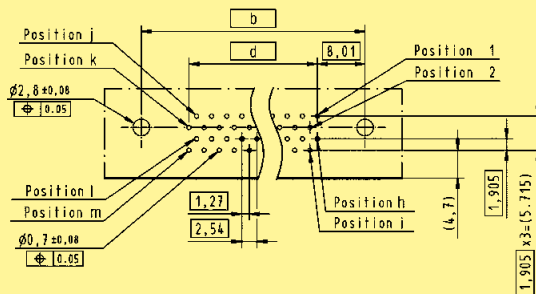

Packaging
(1 reel = 300 pieces)
Reel diameter = 380 mm

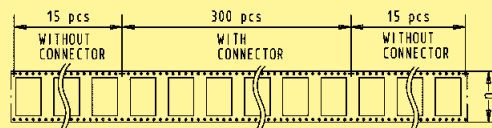

Dimensions in mm

harmik

Number of contacts

14-68



Male connectors for IDC discrete wire, straight

Identification	No. of contacts	Part No.
Male connectors with insulation displacement termination		Male connector
for discrete wire	14	60 13 014 52 . . .
AWG 28/30	20	60 13 020 52 . . .
	26	60 13 026 52 . . .
	36	60 13 036 52 . . .
Insulation diameter (mm)	50	60 13 050 52 . . .
Ø = 0.50-0.65	68	60 13 068 52 . . .
Ø = 0.50-0.75		
Ø = 0.75-0.90		
	00	
	05	
	15	

Available sizes

	Part No.	Ø	14	20	26	36	50	68
Male	60 13 . . . 5200	0.50-0.65		●			●	●
	60 13 . . . 5205	0.50-0.75	●		●	●		
	60 13 . . . 5215	0.75-0.90	●		●	●		

● = Available sizes

Dimensions for male connectors

20 / 50 / 68 poles

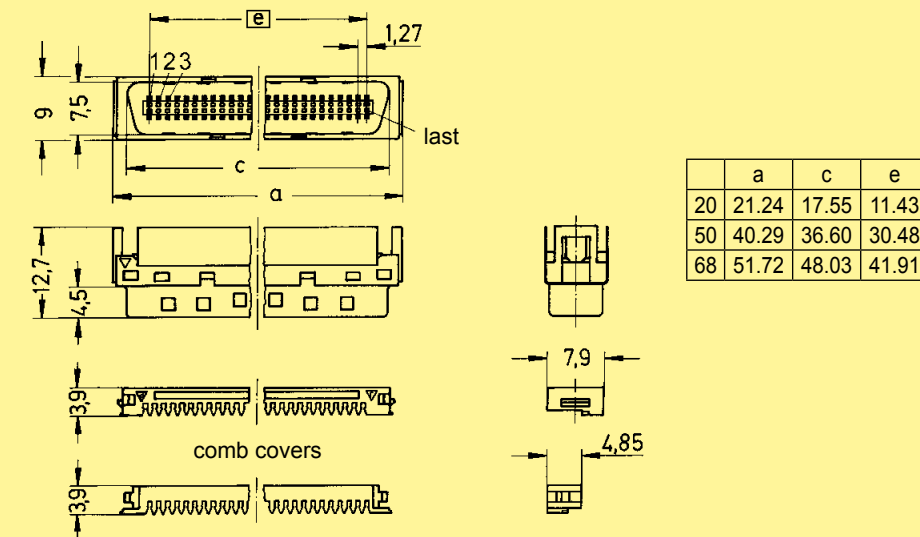

14 / 26 / 36 poles

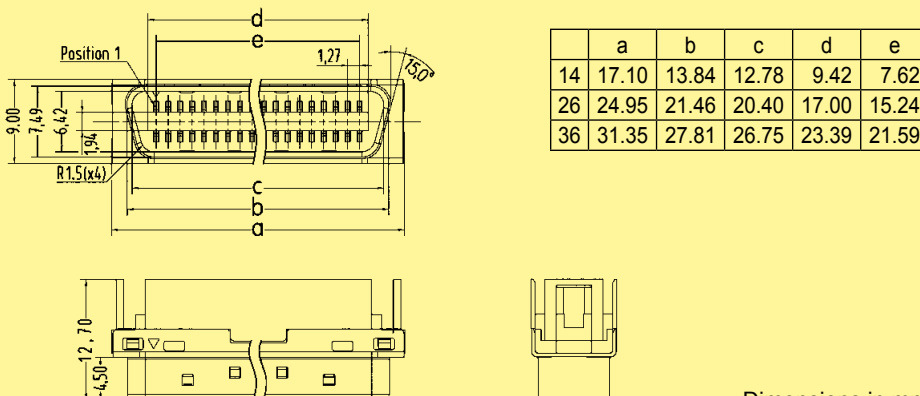

Dimensions in mm



A manual for the *har-mik*® connector and cable assembly is available in our online catalogue *HARKIS*® or on demand at your local HARTING representative.

Hoods for pin and socket male connectors

Number of contacts	20, 26, 36, 50, 68, 100
Surface	Die cast zamac, nickel-plated
	Thermoplastic resin, nickel-plated, steel insert

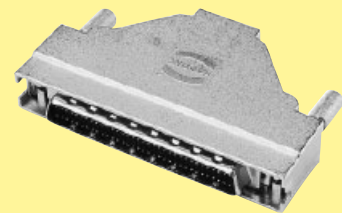
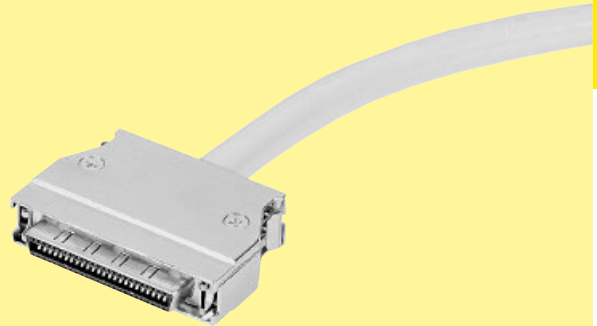

Hoods for bellows male connectors

Number of contacts	14, 20, 26, 36, 50, 68
Surface	Die cast zamac, nickel-plated
	Thermoplastic resin, nickel-plated, steel insert

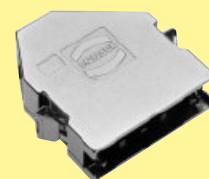

Top entry hoods

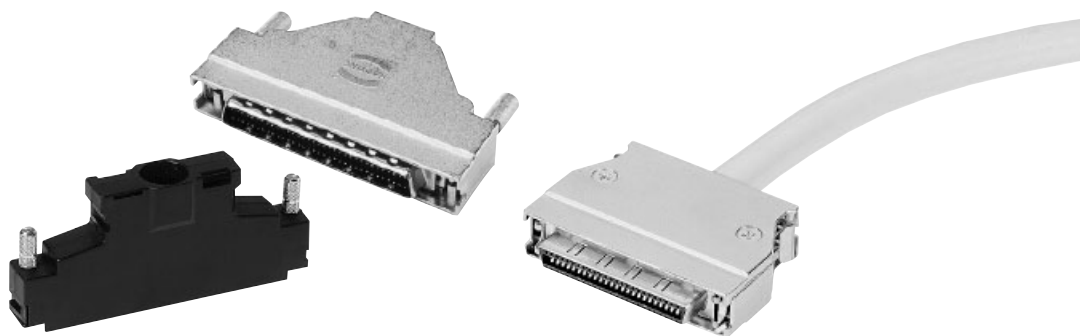

Identification

No. of contacts

Part No.

Drawing

Dimensions in mm

Metal hood
Large cable entry

20	60 03 020 0255
26	60 03 026 0255
36	60 03 036 0255
50	60 03 050 0255
68	60 03 068 0255

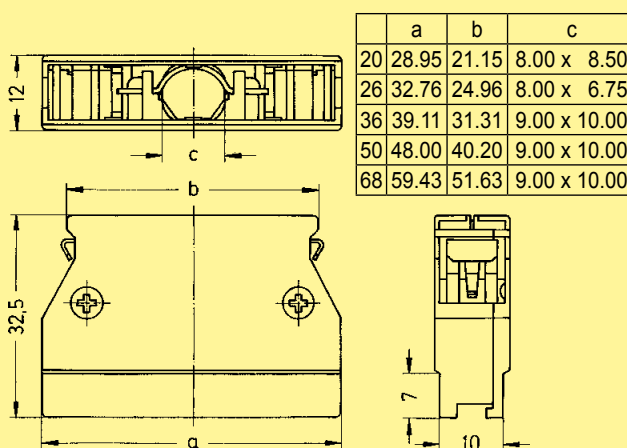

Metal hood
Top cable entry

68	60 03 068 0145
----	----------------

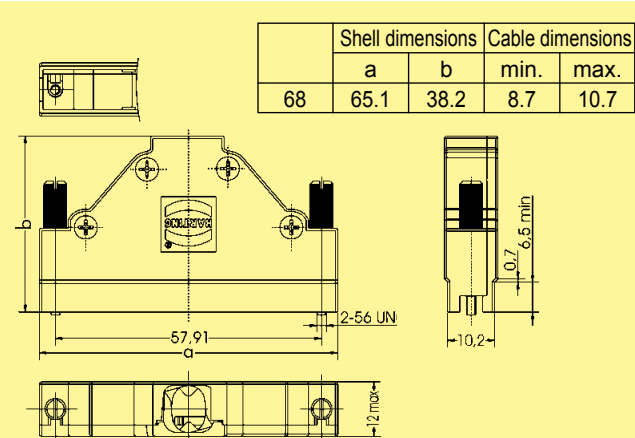

Plastic hood
with internal screen¹⁾

50	60 03 050 0143
68	60 03 068 0143
100	60 03 100 0143

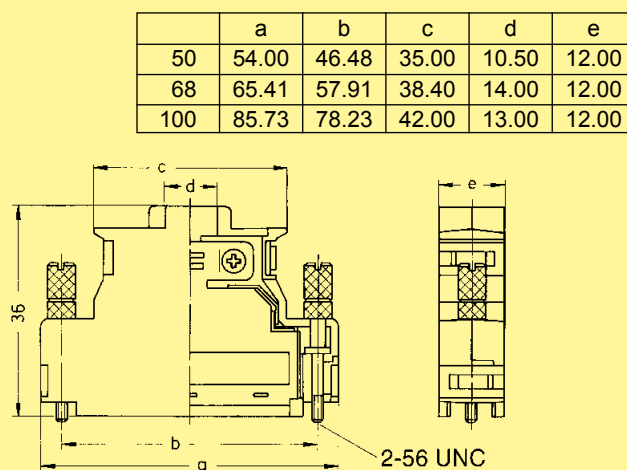

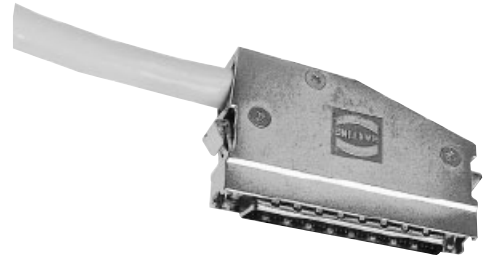

Side entry hoods

harmik

Identification	No. of contacts	Part No.	Drawing	Dimensions in mm
----------------	-----------------	----------	---------	------------------

Metal hood
Cable side entry

20	60 03 020 0555
26	60 03 026 0555
50	60 03 050 0555
68	60 03 068 0555

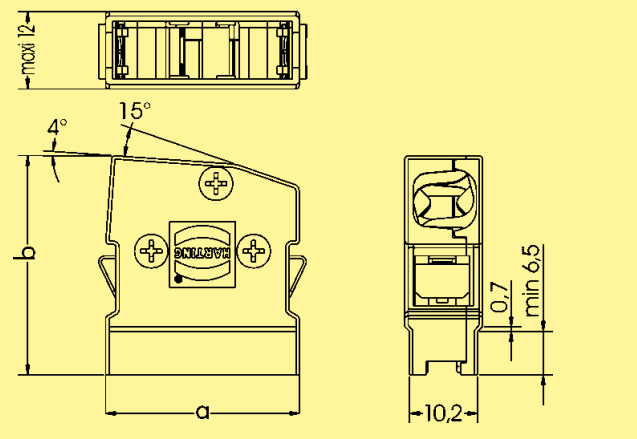

	Shell dimensions		Cable dimensions	
	a	b	min.	max.
20	29.0	32.9	6.2	8.0
26	32.8	32.9	6.5	8.5
50	48.0	35.6	8.3	10.3
68	59.4	35.6	8.7	10.7

Large cable side entry

68	60 03 068 0655
----	----------------

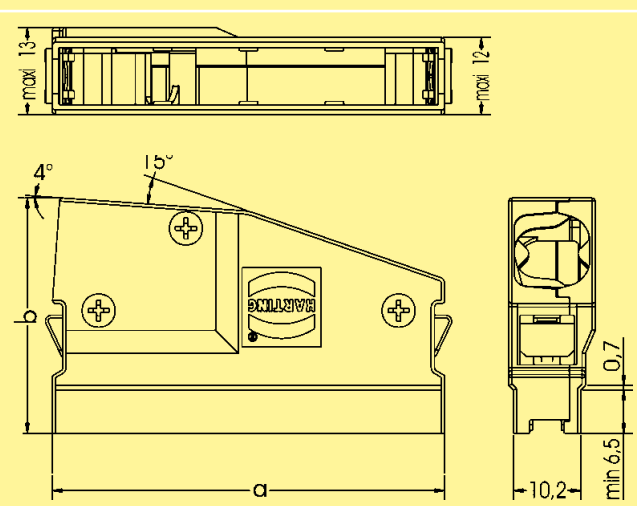

	Shell dimensions		Cable dimensions	
	a	b	min.	max.
68	59.4	35.6	10.0	12.0

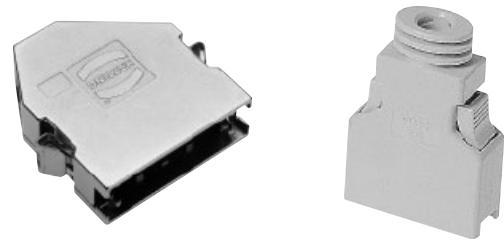

Top or side entry hoods

Identification No. of contacts Part No. Drawing Dimensions in mm

Plastic hood with internal screen

14	60 13 014 0153 351 ¹⁾
20	60 13 020 0153 ²⁾
26	60 13 026 0153 351 ¹⁾
36	60 13 036 0153 351 ¹⁾
50	60 13 050 0153 ²⁾
68	60 13 068 0153 ²⁾

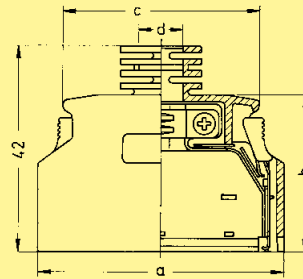

	a	b	c	d
20	29.65	34.50	19.95	6.80
50	48.70	32.00	39.00	8.70
68	60.13	32.00	50.43	9.10

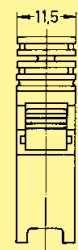

20 / 50 / 68 poles

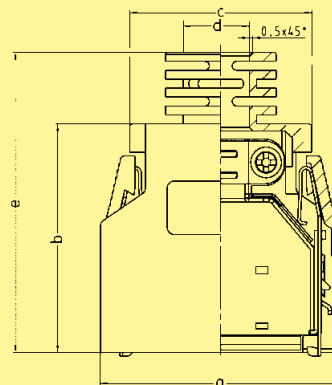

	a	b	c	d	e
14	26.00	36.00	21.00	7.20	42.50
26	33.70	32.00	25.50	8.00	42.00
36	40.05	32.00	31.80	9.20	42.00

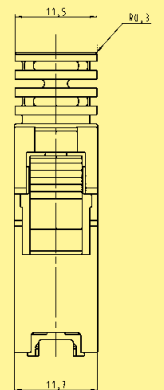

14 / 26 / 36 poles

Metal hood

Cable side entry

Only compatible with IDC connector
60 13 026 5200

26	60 13 026 0555
----	----------------

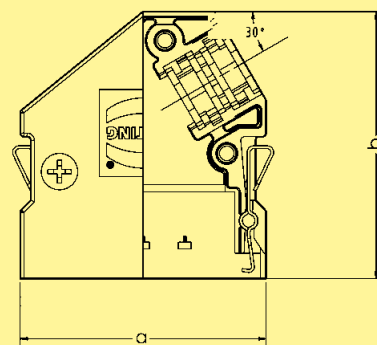

	Shell dimensions		Cable dimensions	
	a	b	min.	max.
26	33.8	36.8	6.5	8.5

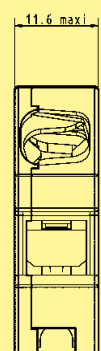

¹⁾ Temperature range: - 55 °C ... + 85 °C
²⁾ Temperature range: - 55 °C ... + 60 °C

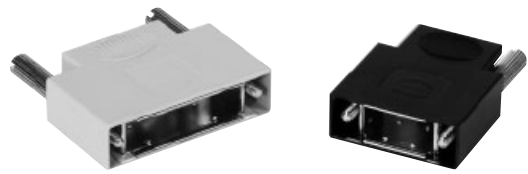

Top entry hoods

harmik

Identification No. of contacts Part No. Drawing Dimensions in mm

Plastic hood with internal screen and knurled screws

Colour: Beige

14 60 13 014 0146 351¹⁾
 26 60 13 026 0146 351¹⁾
 36 60 13 036 0146 351¹⁾

Colour: Black

14 60 13 014 0146 110¹⁾
 26 60 13 026 0146 110¹⁾
 36 60 13 036 0146 110¹⁾

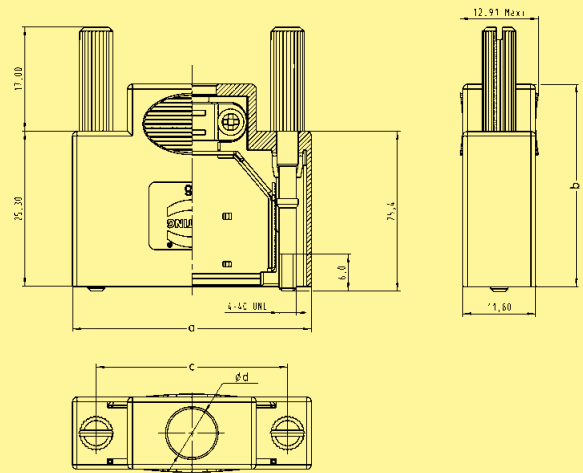

	a	b	c	d
14	31.40	37.00	23.64	7.2
26	39.00	33.00	31.26	8.0
36	45.40	33.00	37.61	9.2

¹⁾ Temperature range: - 55 °C ... + 85 °C



harmik

Female screw lock

Identification Part No. Drawing Dimensions in mm

<p>Screw lock Thread: M 2.5 / 4-40 UNC Height: 4.6 mm</p>	<p>60 01 000 9030</p>	
--	-----------------------	--

<p>Screw lock Thread: M 2.5 / 2-56 UNC Height: 2.9 mm</p>	<p>60 01 000 9013</p>	
--	-----------------------	--

<p>Screw lock Thread: 4-40 UNC / 4-40 UNC Height: 3.99 mm</p>	<p>60 01 000 9018</p>	
--	-----------------------	--

<p>Screw lock Thread: 4-40 UNC / 2-56 UNC Height: 3.99 mm</p>	<p>60 01 000 9019</p>	
--	-----------------------	--

<p>Screw lock Thread: 4-40 UNC / 2-56 UNC Height: 5.5 mm</p>	<p>60 01 000 9020</p>	
---	-----------------------	--

<p>Screw lock Thread: 4-40 UNC / 4-40 UNC Height: 5.5 mm</p>	<p>60 01 000 9021</p>	
---	-----------------------	--

for economical and reliable connections

A comprehensive range of high density intra cabinet connectors based on blade and fork contacts.

Available in a various number of contacts according to the following international standards and applications:

- Small Computer System Interface
SCSI-2
SCSI-2 wide
SCSI-3

- Internal Bus extension through "Daisy chain" inter-linking via 0.635 mm pitch flat cable.
The 4-point design of the IDC contact provides accurate and reliable termination even with teflon cable.

UL recognised

For customer specific applications we can design and manufacture solutions to match your requirement.

Sales department
HARTING components



Certified according to EN ISO 9001
in design/development, production,
installation and servicing

Intra cabinet connectors

Pitch	1.27 mm
Working current	
pcb connector	1 A
Flat cable connector	0.5 A
Working voltage	
pcb connector	240 V ~
Flat cable connector	100 V ~
Test voltage $U_{r.m.s.}$	
pcb connector	750 V
Flat cable connector	500 V
Contact resistance	$\leq 25 \text{ m}\Omega$
Insulation resistance	$\geq 10^3 \text{ M}\Omega$
Temperature range	-55 °C ... + 105 °C
Terminations	
Solder pins	Straight for pcb holes min. $\varnothing 0.74 \text{ mm}$
Insulation displacement	Flat cable AWG 30 pitch 0.635 mm
Materials	
Moulding	Thermoplastic resin glass-fibre filled UL 94-V0
Contacts	
pcb connector	Copper alloy
Flat cable connector	Nickel
Contact surface	
Contact zone	S4 = 0.76 μm (30 μinch) Au or PdNi equivalent

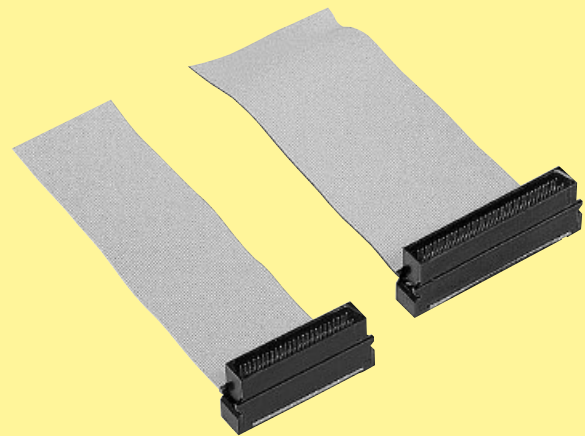
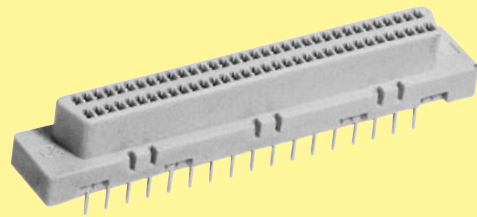
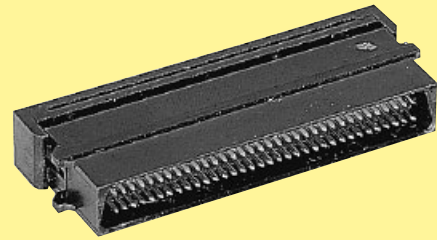

Number of contacts

68

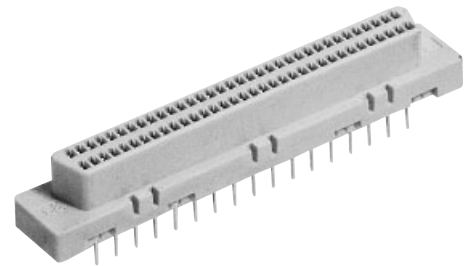

Female connectors, straight

har-mik

Identification	No. of contacts	Part No.
Female connector with straight solder pins	68	60 05 068 5100

Dimensions

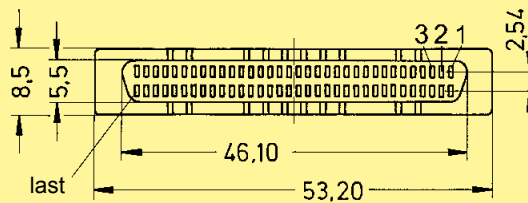
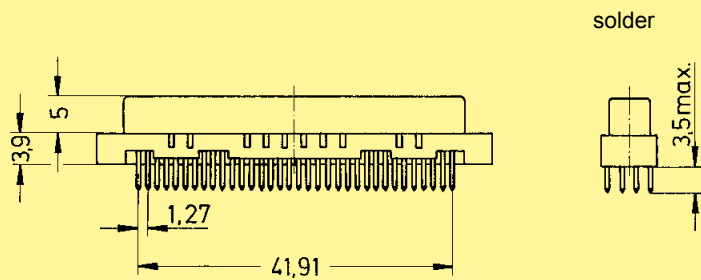

Board drillings
(Components side)

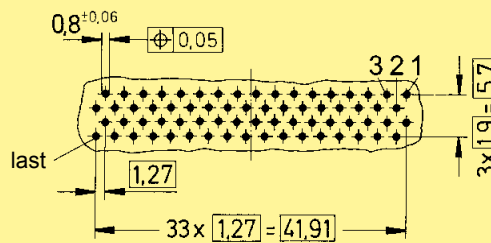

Number of contacts

50–68

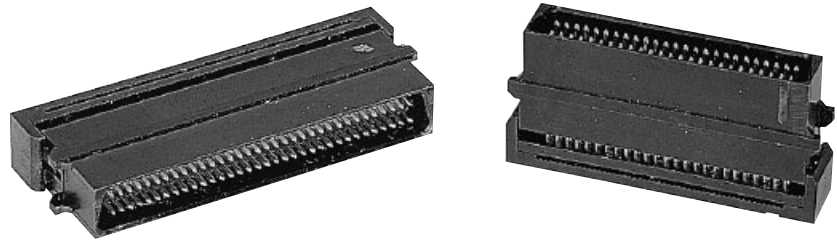

Male connectors for IDC flat cable, straight

Identification	No. of contacts	Part No.
Male connectors with insulation displacement termination for IDC flat cable pitch 0.635 mm AWG 30 Strain relief order separately		Male connector
	50	60 06 050 5440
	68	60 06 068 5440
		Strain relief
		60 06 050 9001
		60 06 068 9001

Dimensions

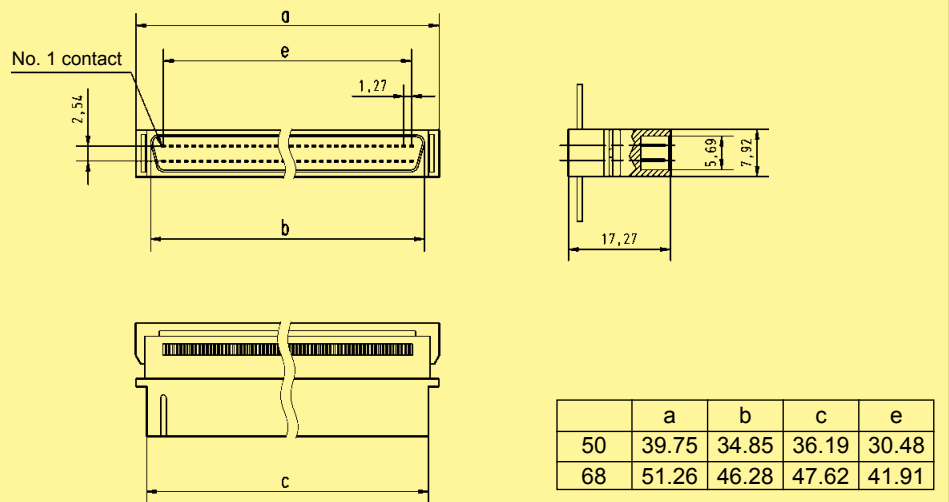

Strain relief

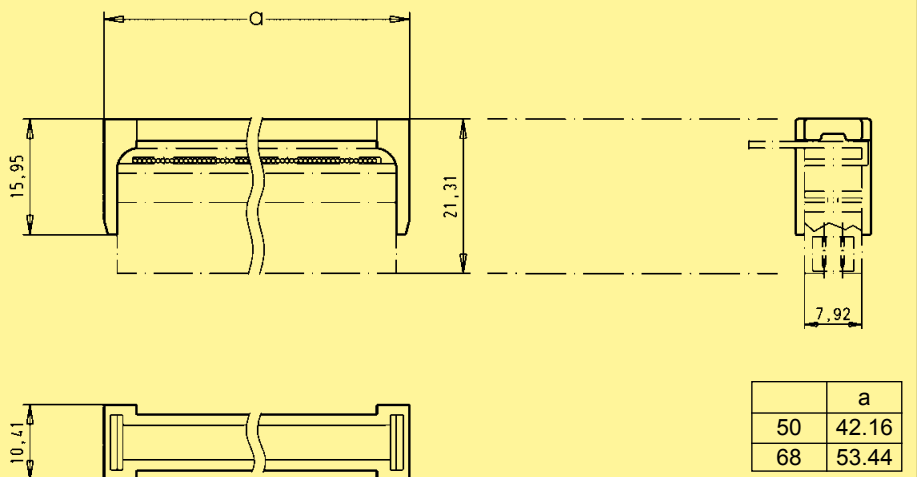

Dimensions in mm

D-Sub – Standard subminiature D connectors

Page

Technical characteristics for solder connectors **02.02**

Versions with straight solder pins **02.04**



Mounting details for angled solder connectors **02.08**

Standard Versions **02.10**

Mounting height 7.3 mm 9-37 way
8.7 mm 50 way



Low-Profile Versions **02.16**

Mounting height 3.6 mm 9-37 way
6.2 mm 50 way



U.S. Footprint Versions **02.20**

Mounting height 6.3 mm 9-37 way



Mounting details **02.22**

Technical characteristics for cable connectors **02.24**

Versions with wrap posts **02.25**



Versions with crimp terminal/crimp contacts **02.26**



Versions with insulation displacement termination **02.32**



Versions with solder buckets **02.34**



Cables and cable assemblies **see chapter 40**



D-Sub - S

02.01

Number of contacts	9, 15, 25, 37, 50 UL recognized
Working current	see current carrying capacity chart
Turned contacts	7.5 A max.
Stamped contacts	6.5 A max.
Test voltage $U_{r.m.s.}$	1 kV
Clearance and creepage	≥ 1.0 mm
Contact resistance	≤ 10 m Ω
Insulation resistance	$\geq 10^{10}$ Ω
Temperature range	-55 °C ... + 125 °C The higher temperature limit includes the local ambient and heating effect of the contacts under load
Terminations	a) Solder pins \varnothing 0.6 mm for P.C.B. holes \varnothing 0.8/1 mm b) Solder pins, angled 90° \varnothing 0.6 mm for P.C.B. holes \varnothing 1 mm
Materials	
Mouldings and hoods	Thermoplastic resin, glass-fibre filled (PBTP), UL 94-V0
Contacts	Copper alloy
Contact surface	
Contact zone	selectively plated according to performance level ¹⁾
Metal shell	Plated steel
Insertion and withdrawal force	
Connector on P.C.B.	
Solder, straight with clips	
- insertion max. per connector:	60 N
- withdrawal min. per connector:	10 N
Mating force	
9 way	≤ 30 N
15 way	≤ 50 N
25 way	≤ 83 N
37 way	≤ 123 N
50 way	≤ 167 N

Current carrying capacity

The current carrying capacity is limited by maximum temperature of materials for inserts and contacts including terminals. The current capacity-curve is valid for continuous, not interrupted current-loaded contacts of connectors when simultaneous power on all contacts is given, without exceeding the maximum temperature.

Control and test procedures according to DIN IEC 60 512.

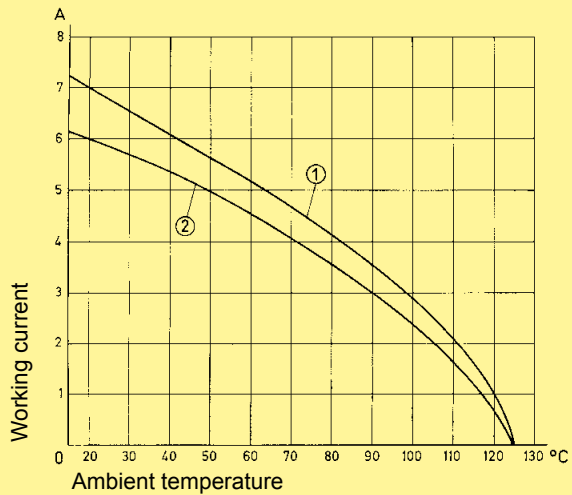

Example: 25 way connector

- ① Turned contacts
- ② Stamped contacts

Contact arrangement View from termination side

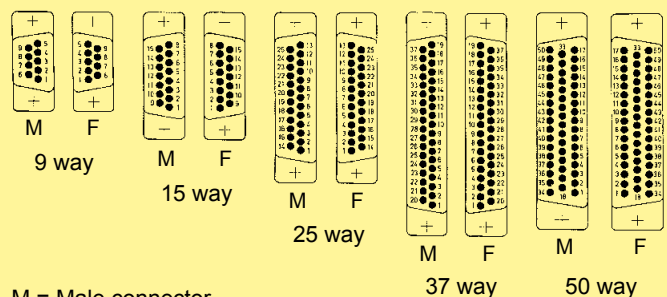

M = Male connector
F = Female connector

Mating conditions as per DIN 41 652

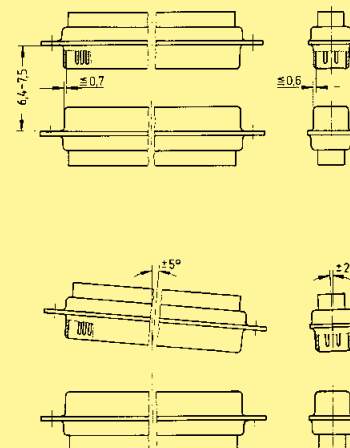

¹⁾ Performance level 3, 50 mating cycles, no gas test
Performance level 2 as per CECC 75 301-802, 250 mating cycles, 4 days 4 mixed gas test – IEC 60 512
Performance level 1 as per CECC 75 301-802, 500 mating cycles, 10 days 4 mixed gas test – IEC 60 512

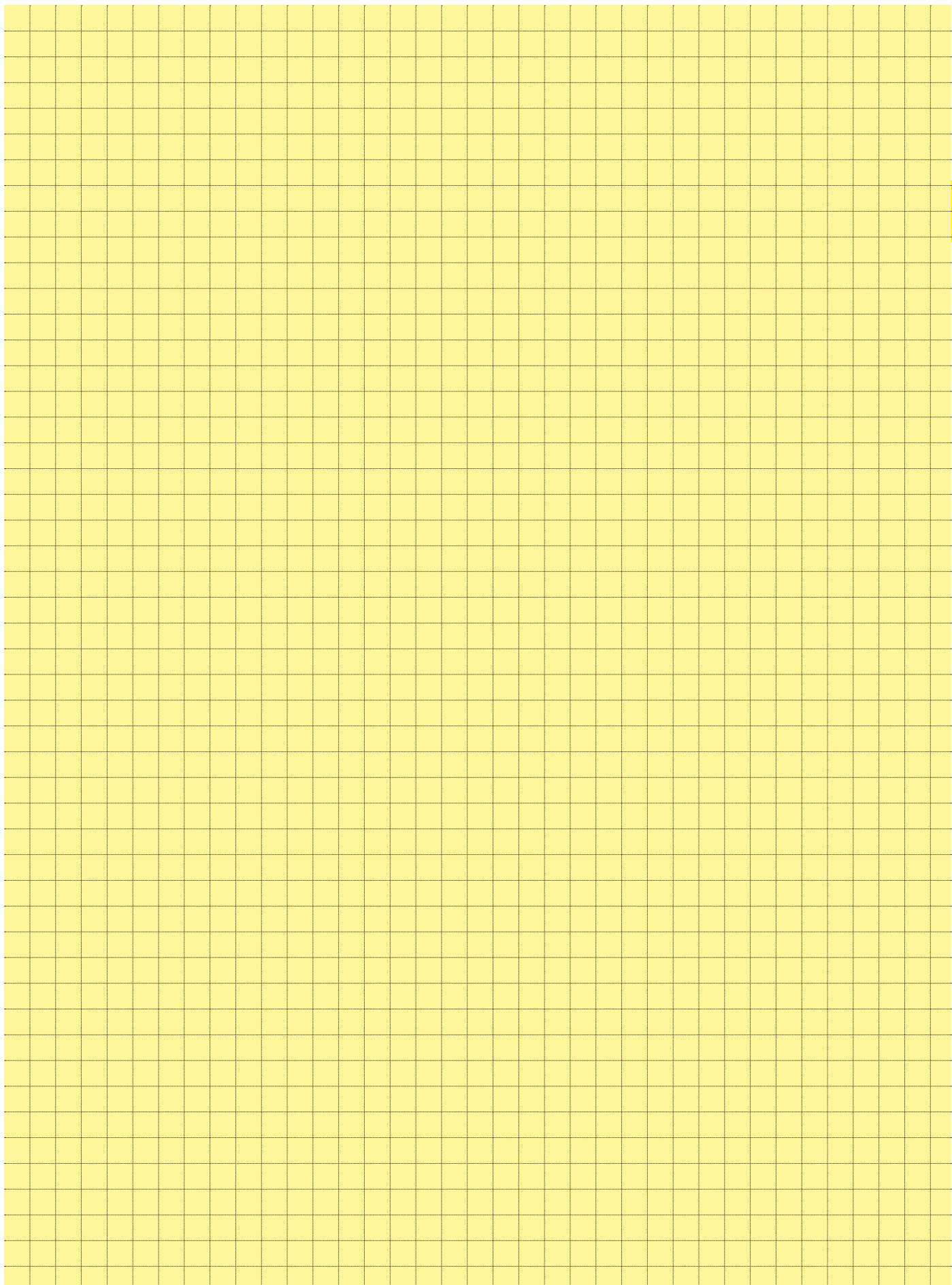

Number of contacts

9-50

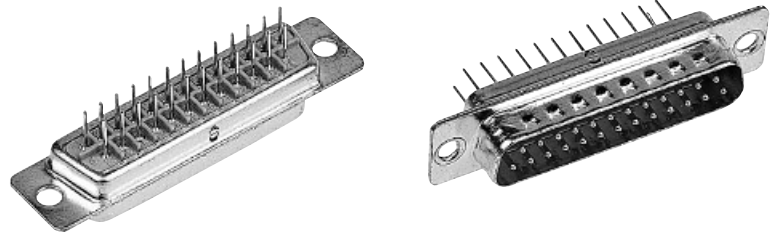

Turned solder pins, straight

D-Sub - S

Identification	No. of contacts	Part No.	
Performance levels Explanations see page 02.02 Other performance levels on request		Performance level 3	Performance level 2
Male connector metal shell with dimples	9 15 25 37 50	09 67 009 5654 09 67 015 5654 09 67 025 5654 09 67 037 5654 09 67 050 5654 ¹⁾	09 67 009 5655 09 67 015 5655 09 67 025 5655 09 67 037 5655 09 67 050 5655 ¹⁾
Female connector metal shell	9 15 25 37 50	09 67 009 4754 09 67 015 4754 09 67 025 4754 09 67 037 4754 09 67 050 4754 ¹⁾	09 67 009 4755 09 67 015 4755 09 67 025 4755 09 67 037 4755 09 67 050 4755 ¹⁾

Male connector

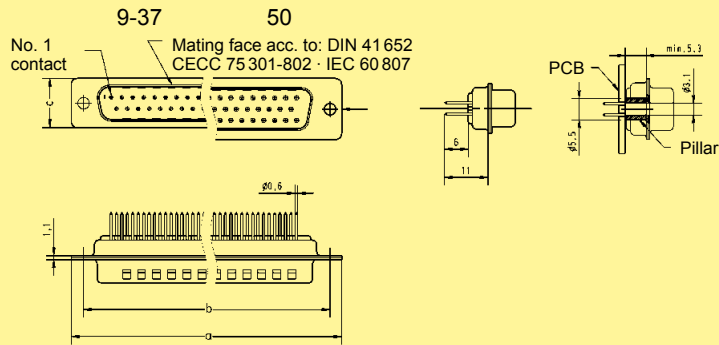

Female connector

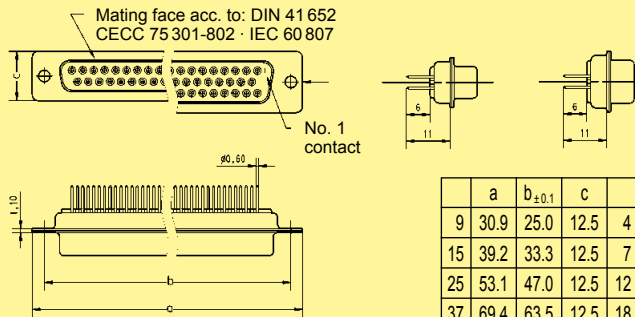

	a	b _{±0.1}	c	g	h
9	30.9	25.0	12.5	4 x 2.74 = 10.96	3 x 2.74 = 8.22
15	39.2	33.3	12.5	7 x 2.74 = 19.18	6 x 2.74 = 16.44
25	53.1	47.0	12.5	12 x 2.76 = 33.12	11 x 2.76 = 30.36
37	69.4	63.5	12.5	18 x 2.76 = 49.68	17 x 2.76 = 46.92
50	67.0	61.1	15.4	16 x 2.76 = 44.16	15 x 2.76 = 41.40

Board drillings

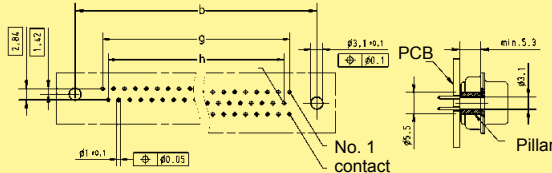

Dimensions in mm

¹⁾ Not normally kept in stock

Mating conditions see page 02.02

Number of contacts

9-50

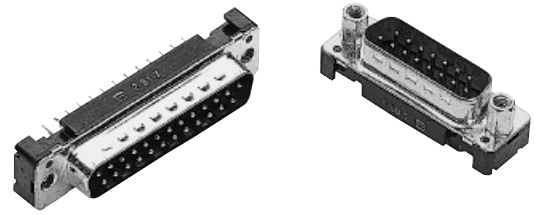

Turned solder pins, straight without grounding-pins

Identification	No. of contacts	Part No.	
Performance levels Explanations see page 02.02 Other performance levels on request		Performance level 3	Performance level 2
Male connector metal shell with dimples			
available on request	9	09 66 121 770 .	09 66 121 670 .
	15	09 66 221 770 .	09 66 221 670 .
	25	09 66 321 770 .	09 66 321 670 .
	37	09 66 421 770 .	09 66 421 670 .
	50	09 66 521 770 .	09 66 521 670 .
Please insert digit for flange thread or fitted female screw locks			
	M3 ▶ 1 4-40 UNC ▶ 2 fitted screw locks 4-40 UNC ▶ 3		

Male connector

9-37 50

Mating face acc. to: DIN 41 652
CECC 75 301-802 · IEC 60 807

	a	b _{±0.1}	c	g	h
9	30.9	25.0	12.9	4 x 2.74 = 10.96	3 x 2.74 = 8.22
15	39.2	33.3	12.9	7 x 2.74 = 19.18	6 x 2.74 = 16.44
25	53.1	47.0	12.9	12 x 2.76 = 33.12	11 x 2.76 = 30.36
37	69.4	63.5	12.9	18 x 2.76 = 49.68	17 x 2.76 = 46.92
50	67.0	61.1	15.7	16 x 2.76 = 44.16	15 x 2.76 = 41.40

Dimples

No. 1 contact

M3 or
4-40 UNC

fitted screw locks
4-40 UNC

Dimensions in mm

Board drillings

Mating conditions see page 02.02

Number of contacts

9-50

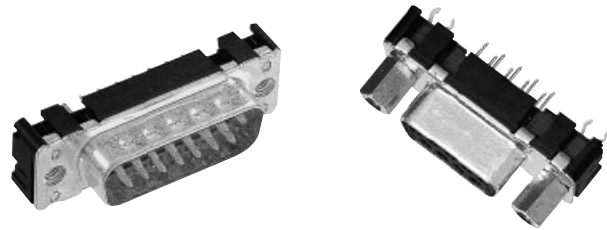

Stamped solder pins, straight with/without grounding board locks

D-Sub - S

Identification	No. of contacts	Part No.	
Performance levels Explanations see page 02.02 Other performance levels on request		Performance level 3	Performance level 2
Male connector metal shell with dimples			
Without grounding board locks	9 15 25 37	09 65 121 770 09 65 221 770 09 65 321 770 09 65 421 770	09 65 121 670 09 65 221 670 09 65 321 670 09 65 421 670
With grounding board locks	9 15 25 37	09 65 161 771 09 65 261 771 09 65 361 771 09 65 461 771	09 65 161 671 09 65 261 671 09 65 361 671 09 65 461 671
Female connector metal shell			
Without grounding board locks	9 15 25 37 50	09 66 111 750 09 66 211 750 09 66 311 750 09 66 411 750 09 66 511 750	09 66 111 650 09 66 211 650 09 66 311 650 09 66 411 650 09 66 511 650
With grounding board locks	9 15 25 37	09 66 151 751 09 66 251 751 09 66 351 751 09 66 451 751	09 66 151 651 09 66 251 651 09 66 351 651 09 66 451 651
Please insert digit for flange thread or fitted female screw locks			
M3 ▶ 1			
4-40 UNC ▶ 2			
fitted screw locks 4-40 UNC ▶ 3 ¹⁾			

¹⁾ Fitted screw locks 4-40 UNC not normally kept in stock for performance level 3
Connector dimensions see page 02.07. Mating conditions see page 02.02.

Number of contacts

9–50

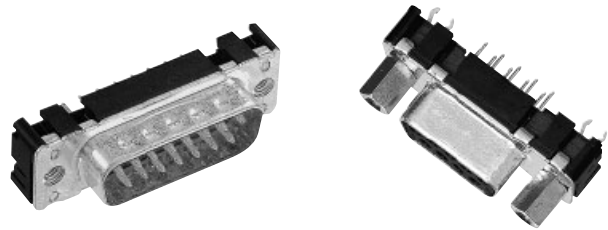

Stamped solder pins, straight with/without grounding board locks

Identification

Drawing

Dimensions in mm

Male connector
9 – 37 contacts

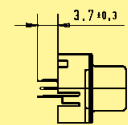
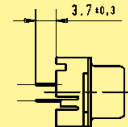
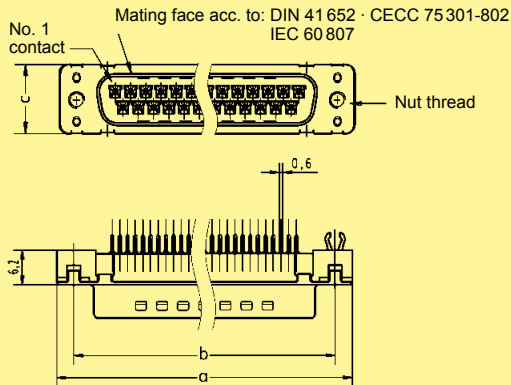

Female connector
9 – 37 contacts

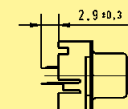
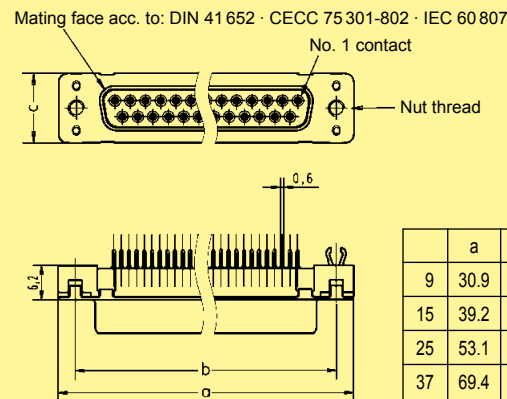

	a	b _{±0.1}	c	g	h
9	30.9	25.0	12.5	4 x 2.74 = 10.96	3 x 2.74 = 8.22
15	39.2	33.3	12.5	7 x 2.74 = 19.18	6 x 2.74 = 16.44
25	53.1	47.0	12.5	12 x 2.76 = 33.12	11 x 2.76 = 30.36
37	69.4	63.5	12.5	18 x 2.76 = 49.68	17 x 2.76 = 46.92

Board drillings
9 – 37 contacts

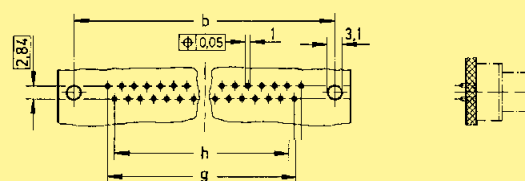

D-Sub - S

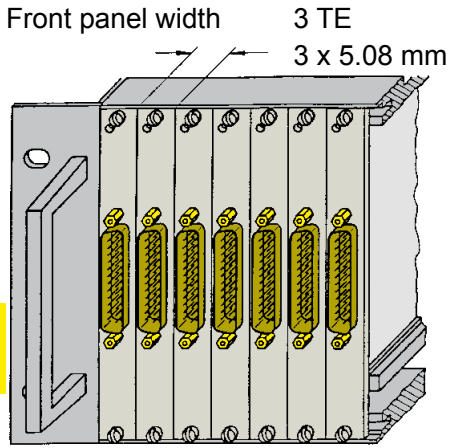

Low-Profile Versions
pages 02.16 – 02.19

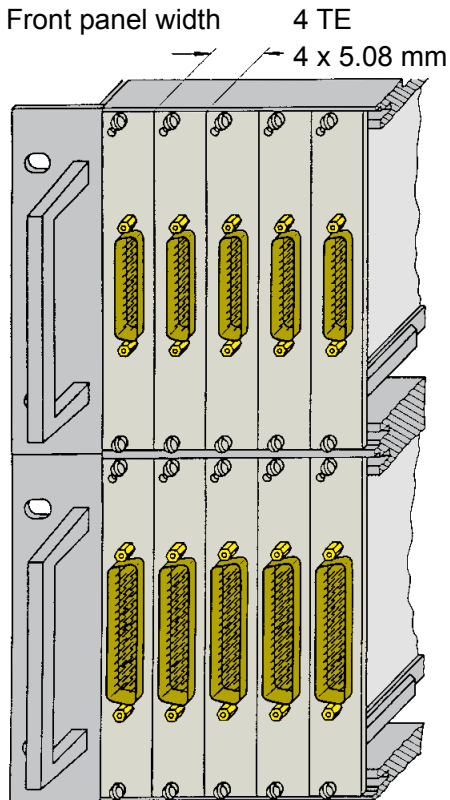
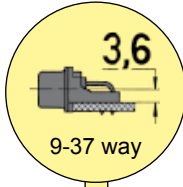

Standard Versions
pages 02.10 – 02.15

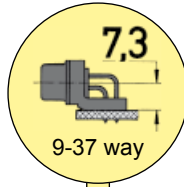

U.S. Footprint Versions
pages 02.20 – 02.21

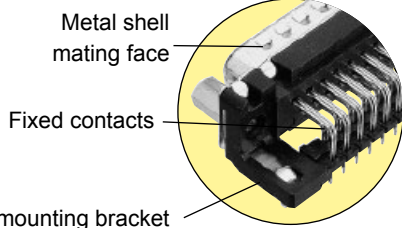
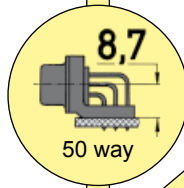
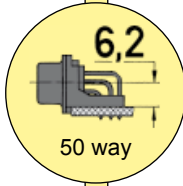
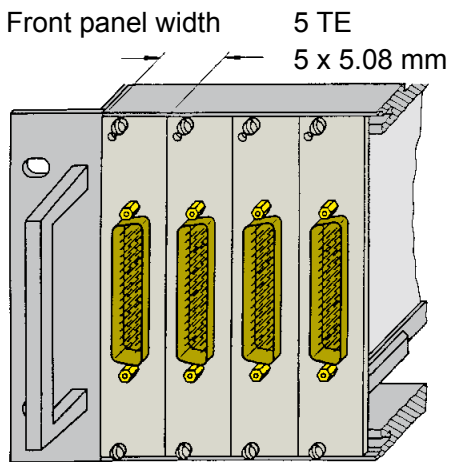
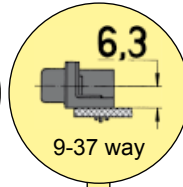

Advantages

- All-round protective metal shell
- Polarisation
- Contact protection
- Plated shell
- Male connector with dimples

Plated terminations for increased solderability

Grounding contact riveted to metal shell

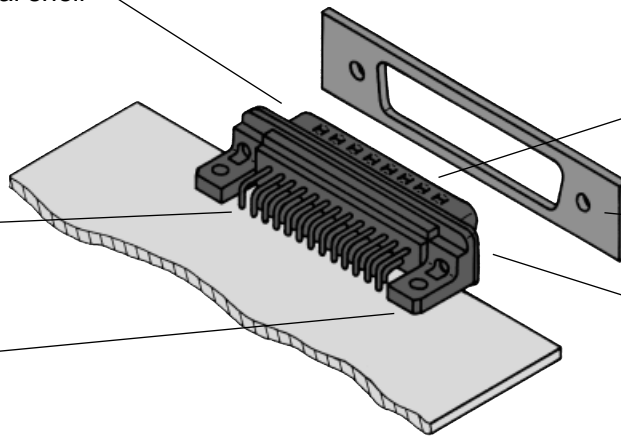

Contact surface finish to different performance levels

Panel

Different metal threads possible in flange area

- M3
- 4-40 UNC
- fitted female screw locks 4-40 UNC
- max. torque ≤ 0.8 Nm

Integrated plastic mounting bracket

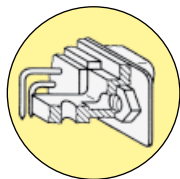

Mounting bracket

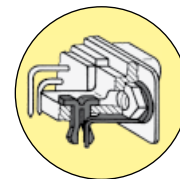

Mounting bracket with snap-in-clips and grounding pin

Mounting height

Low-Profile Versions

The reduced mounting height of these connectors allow them to be used on the same PCB as DIN 41 612

types with no loss of packaging density when card frames to DIN 41 494 are used.

9-37 way connectors with 3.6 mm mounting height can be fitted to front panels of 3 TE (15.24 mm) width.

50 way connectors with 6.2 mm mounting height can be fitted to front panels of 4 TE (20.32 mm) width.

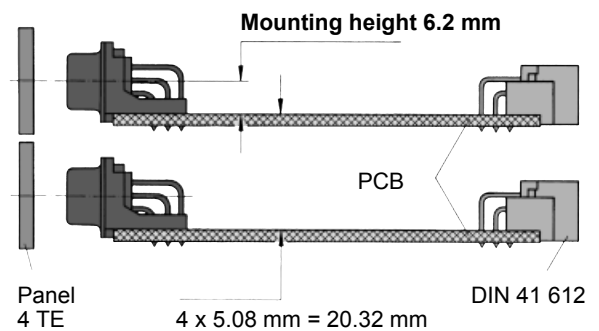
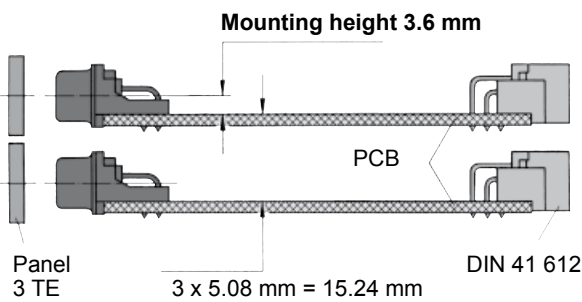

Standard Versions US Footprint

9-37 way connectors with 7.3 mm mounting height can be fitted to front panels of 4 TE (20.32 mm) width.

50 way connectors with 8.7 mm mounting height can be fitted to front panels of 5 TE (25.4 mm) width.

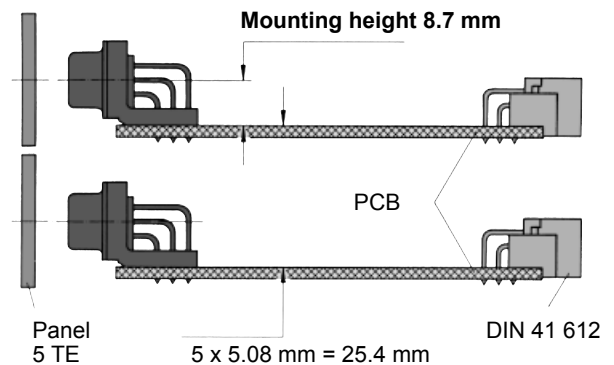
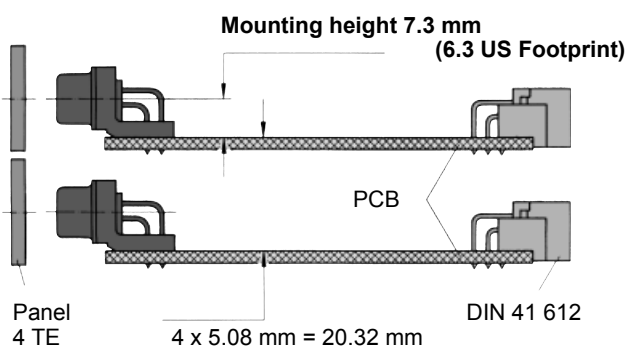

D-Sub - S

Number of contacts

Mounting height

Standard Versions

9-37
50

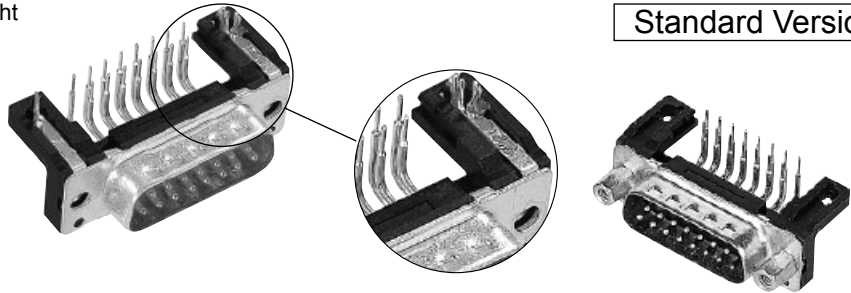
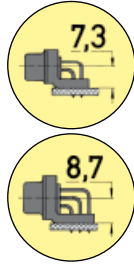

Turned solder pins, angled with/without snap-in-clips and grounding board locks

D-Sub - S

Identification	No. of contacts	Part No.	
Performance levels Explanations see page 02.02 Other performance levels on request		Performance level 3	
		Performance level 2	
Male connector metal shell with dimples		2.84 mm pitch	
With snap-in clips and grounding board locks	9	09 66 163 781	09 66 163 681
	15	09 66 263 781	09 66 263 681
	25	09 66 363 781	09 66 363 681
	37	09 66 463 781	09 66 463 681
	50	09 66 563 781	09 66 563 681
 available on request		2.54 mm pitch	
	9	09 66 162 781	09 66 162 681
	15	09 66 262 781	09 66 262 681
	25	09 66 362 781	09 66 362 681
	37	09 66 462 781	09 66 462 681
50	09 66 562 781	09 66 562 681	
Without snap-in clips and grounding board locks		2.84 mm pitch	
	9	09 66 123 780	09 66 123 680
	15	09 66 223 780	09 66 223 680
	25	09 66 323 780	09 66 323 680
	37	09 66 423 780	09 66 423 680
 available on request		2.54 mm pitch	
	9	09 66 122 780	09 66 122 680
	15	09 66 222 780	09 66 222 680
	25	09 66 322 780	09 66 322 680
	37	09 66 422 780	09 66 422 680
50	09 66 522 780	09 66 522 680	
Please insert digit for flange thread or fitted female screw locks			
	M3 ▶	1	
	4-40 UNC ▶	2	
	fitted screw locks 4-40 UNC ▶	3	

Number of contacts

Mounting height

Standard Versions

9-37
50

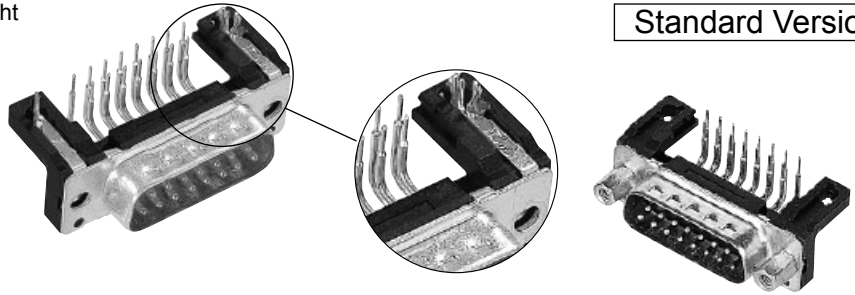
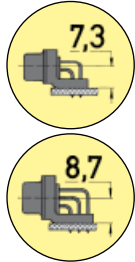

Turned solder pins, angled with/without snap-in-clips and grounding board locks

Identification

Drawing

Dimensions in mm

Male connector

With snap-in clips and grounding board locks

Without snap-in clips and grounding board locks

Board drillings

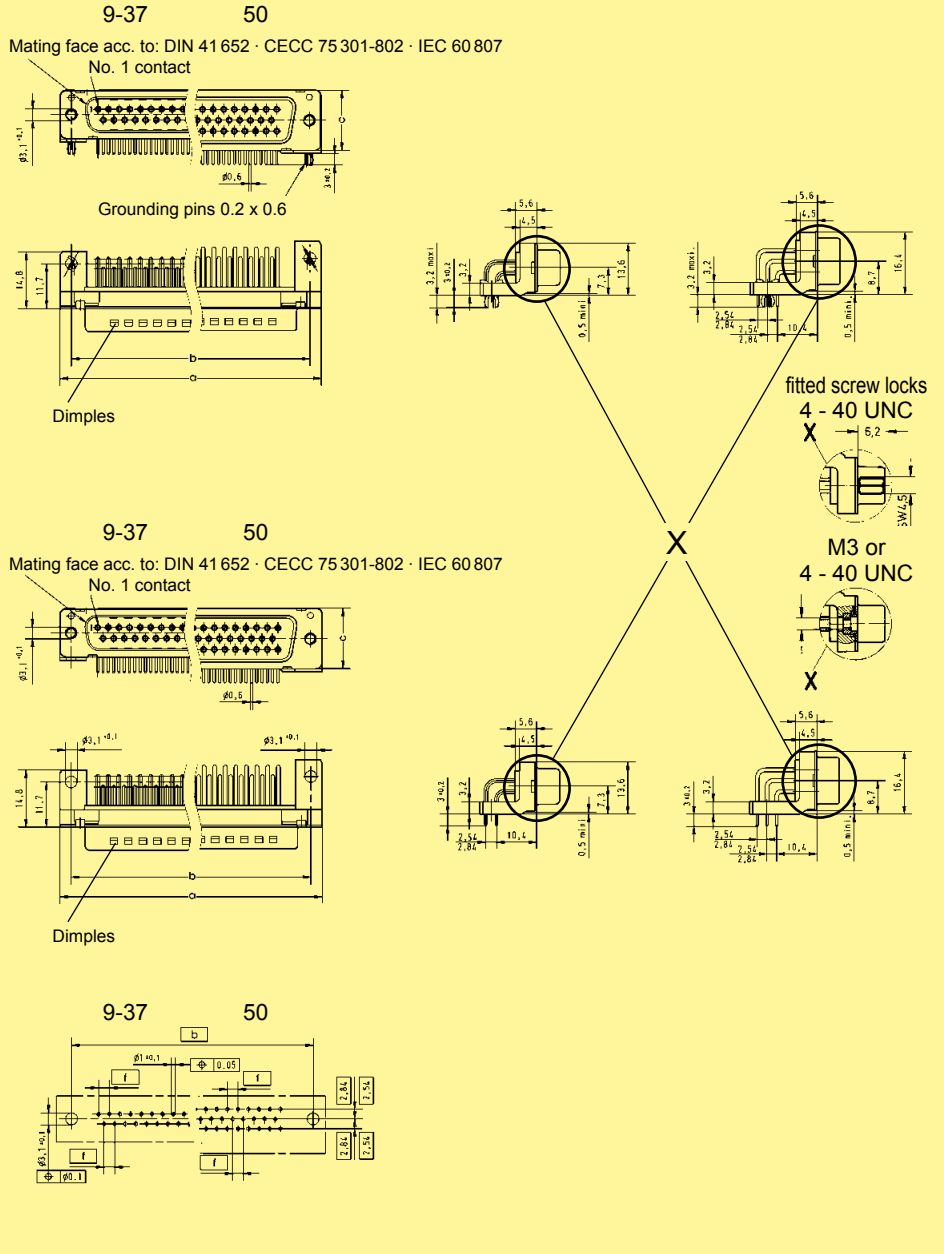

	a	b±0.1	c	f
9	30.90	25.00	12.90	2.74
15	39.20	33.30	12.90	2.74
25	53.10	47.00	12.90	2.76
37	69.40	63.50	12.90	2.76
50	67.00	61.10	15.70	2.76

D-Sub - S

Number of contacts

Mounting height

9-37
50

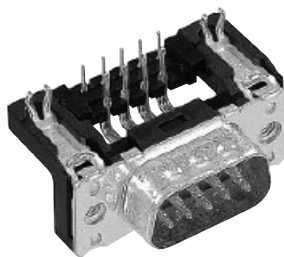
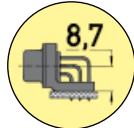
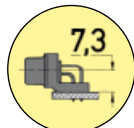

Standard Versions

Stamped solder pins, angled with grounding board locks

D-Sub - S

Identification	No. of contacts	Part No.		
Performance levels Explanations see page 02.02 Other performance levels on request		Performance level 3		
		Performance level 2		
Male connector metal shell with dimples		2.84 mm pitch		
	9	09 65 163 781 . 1)	09 65 163 681 . 1)	
	15	09 65 263 781 . 1)	09 65 263 681 . 1)	
	25	09 65 363 781 . 1)	09 65 363 681 . 1)	
	37	09 65 463 781 . 1)	09 65 463 681 . 1)	
		2.54 mm pitch		
	9	09 65 162 781 .	09 65 162 681 .	
	15	09 65 262 781 .	09 65 262 681 .	
	25	09 65 362 781 .	09 65 362 681 .	
	37	09 65 462 781 .	09 65 462 681 .	
	Female connector metal shell		2.84 mm pitch	
		9	09 66 153 761 . 1)	09 66 153 661 . 1)
		15	09 66 253 761 . 1)	09 66 253 661 . 1)
		25	09 66 353 761 . 1)	09 66 353 661 . 1)
37		09 66 453 761 . 1)	09 66 453 661 . 1)	
		2.54 mm pitch		
9		09 66 152 761 .	09 66 152 661 .	
15		09 66 252 761 .	09 66 252 661 .	
25		09 66 352 761 .	09 66 352 661 .	
37		09 66 452 761 .	09 66 452 661 .	
50		09 66 552 761 . 1)	09 66 552 661 . 1)	
Please insert digit for flange thread or fitted female screw locks				
Ø 3.1 mm hole ▶ 0 ¹⁾				
M3 ▶ 1				
4-40 UNC ▶ 2				
fitted screw locks 4-40 UNC ▶ 3				

¹⁾ Not normally kept in stock

Number of contacts

Mounting height

9-37
50

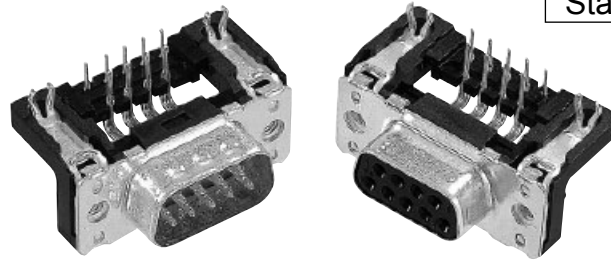
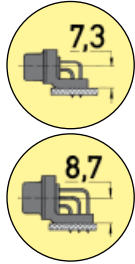

Standard Versions

Stamped solder pins, angled with grounding board locks

Identification

Drawing

Dimensions in mm

Male connector

Mating face acc. to: DIN 41 652 · CECC 75 301-802
IEC 60 807

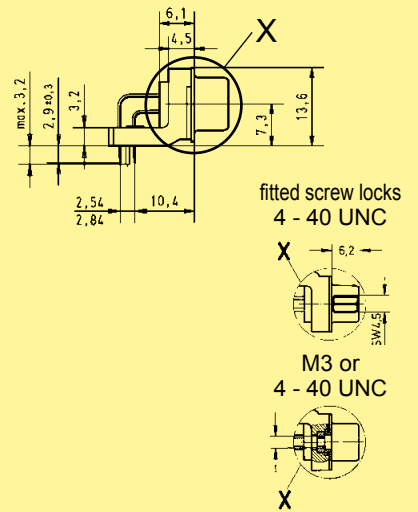
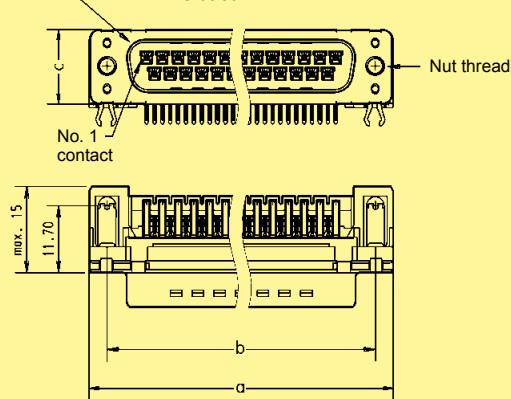

Female connector

9-37 50

Mating face acc. to: DIN 41 652 · CECC 75 301-802
IEC 60 807

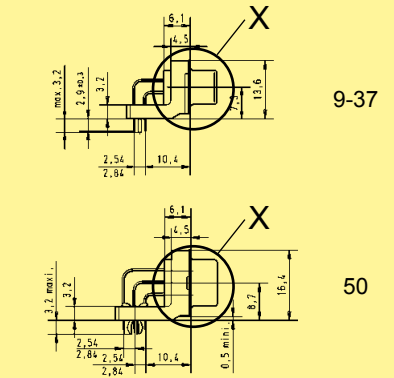
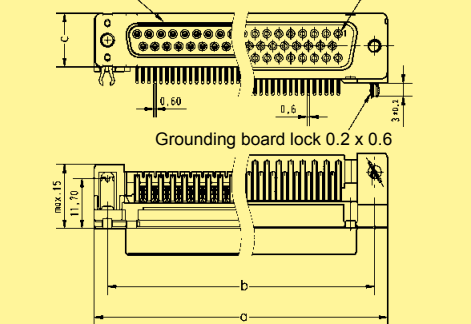

Board drillings

9-37 50

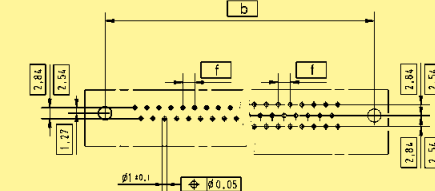

	a	b±0.1	c	f
9	30.90	25.00	12.50	2.74
15	39.20	33.30	12.50	2.74
25	53.10	47.00	12.50	2.76
37	69.40	63.50	12.50	2.76
50	67.00	61.10	15.40	2.76

Number of contacts

Mounting height

Standard Versions

9-37
50

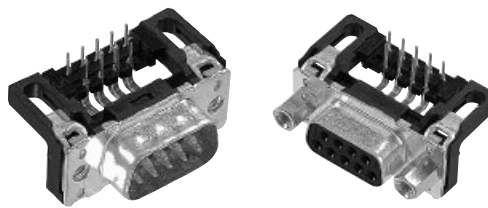
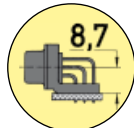
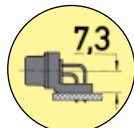

Stamped solder pins, angled without grounding board locks

D-Sub - S

Identification	No. of contacts	Part No.	
Performance levels Explanations see page 02.02 Other performance levels on request		Performance level 3	
		Performance level 2	
Male connector metal shell with dimples		2.84 mm pitch	
	9	09 65 123 780 . 1)	09 65 123 680 . 1)
	15	09 65 223 780 . 1)	09 65 223 680 . 1)
	25	09 65 323 780 . 1)	09 65 323 680 . 1)
	37	09 65 423 780 . 1)	09 65 423 680 . 1)
		2.54 mm pitch	
	9	09 65 122 780 .	09 65 122 680 .
	15	09 65 222 780 .	09 65 222 680 .
	25	09 65 322 780 .	09 65 322 680 .
	37	09 65 422 780 .	09 65 422 680 .
Female connector metal shell		2.84 mm pitch	
	9	09 66 113 760 . 1)	09 66 113 660 . 1)
	15	09 66 213 760 . 1)	09 66 213 660 . 1)
	25	09 66 313 760 . 1)	09 66 313 660 . 1)
	37	09 66 413 760 . 1)	09 66 413 660 . 1)
		2.54 mm pitch	
	9	09 66 112 760 .	09 66 112 660 .
	15	09 66 212 760 .	09 66 212 660 .
	25	09 66 312 760 .	09 66 312 660 .
	37	09 66 412 760 .	09 66 412 660 .
50	09 66 512 760 . 1)	09 66 512 660 . 1)	
Please insert digit for flange thread or fitted female screw locks			
Ø 3.1 mm hole ▶ 0 ¹⁾			
M3 ▶ 1			
4-40 UNC ▶ 2			
fitted screw locks 4-40 UNC ▶ 3			

¹⁾ Not normally kept in stock

Number of contacts

Mounting height

Standard Versions

9-37
50

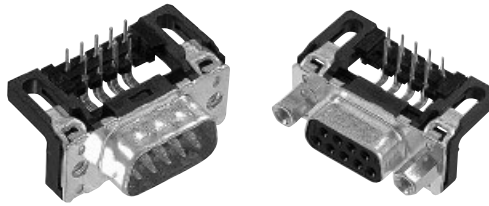
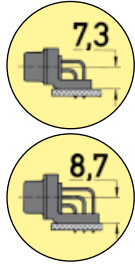

Stamped solder pins, angled without grounding board locks

Identification

Drawing

Dimensions in mm

Male connector

Mating face acc. to: DIN 41 652 · CECC 75 301-802 · IEC 60 807

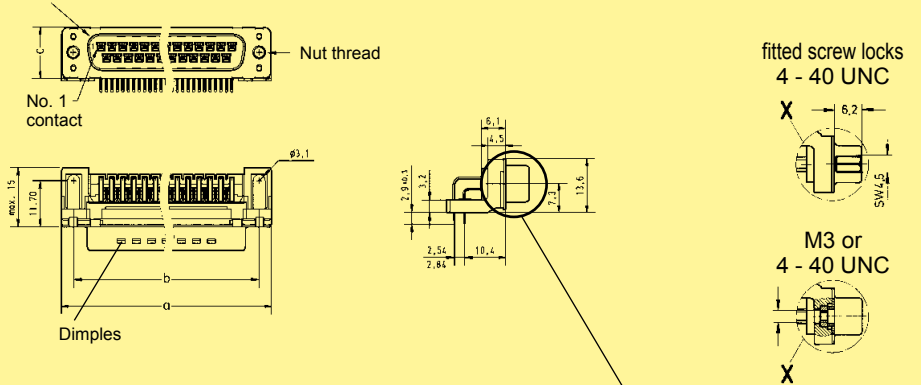

Female connector

9-37 50
Mating face acc. to: DIN 41 652 · CECC 75 301-802 · IEC 60 807

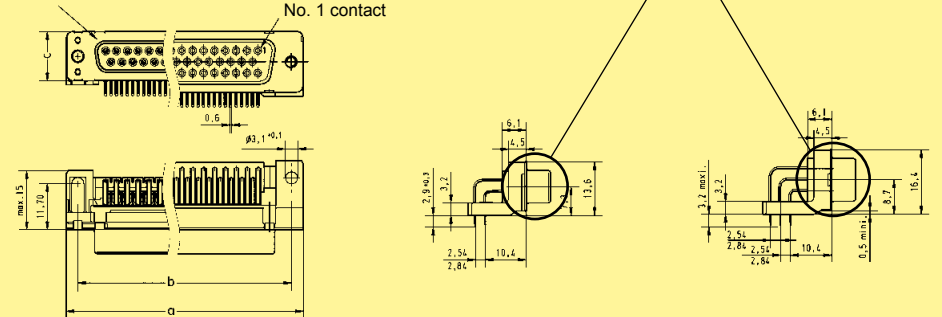

Board drillings

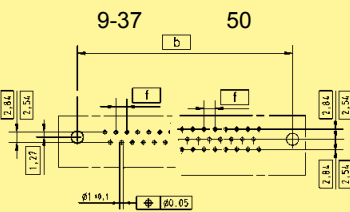

	a	b ± 0.1	c	f
9	30.90	25.00	12.50	2.74
15	39.20	33.30	12.50	2.74
25	53.10	47.00	12.50	2.76
37	69.40	63.50	12.50	2.76
50	67.00	61.10	15.40	2.76

Number of contacts

Mounting height

Low-Profile Versions

9-37
50

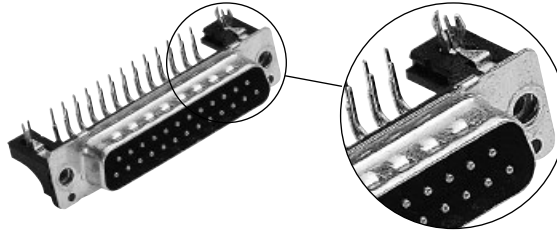
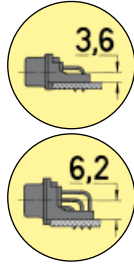

Turned solder pins, angled with snap-in-clips and grounding board locks

D-Sub - S

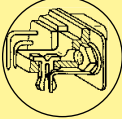
Identification	No. of contacts	Part No.	
<p>Performance levels Explanations see page 02.02 Other performance levels on request</p> <p>Male connector metal shell with dimples</p>  <p>available on request</p>		<p>Performance level 3</p> <p>2.54 mm pitch</p> <p>9 09 66 162 781 . 15 09 66 262 781 . 25 09 66 362 781 . 37 09 66 462 781 . 50 09 66 562 781 .</p>	<p>Performance level 2</p> <p>2.54 mm pitch</p> <p>9 09 66 162 681 . 15 09 66 262 681 . 25 09 66 362 681 . 37 09 66 462 681 . 50 09 66 562 681 .</p>
<p>Please insert digit for flange thread or fitted female screw locks</p> <p>M3 ▶ 5 4-40 UNC ▶ 6 fitted screw locks 4-40 UNC ▶ 7</p>			

Number of contacts

Mounting height

Low-Profile Versions

9-37
50

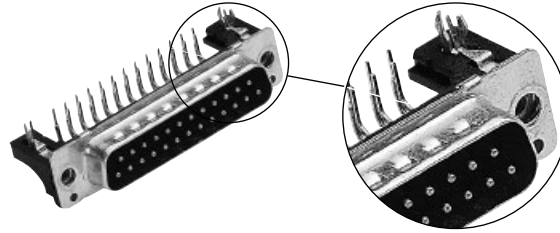
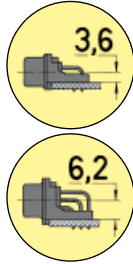

Turned solder pins, angled with snap-in-clips and grounding board locks

Identification

Drawing

Dimensions in mm

Male connector

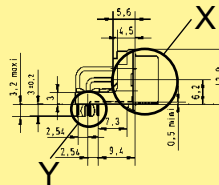
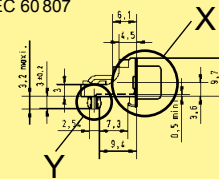
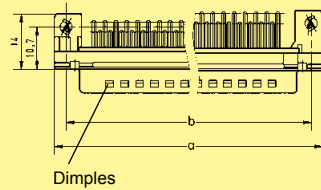
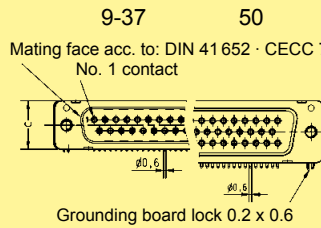

fitted screw locks
4 - 40 UNC

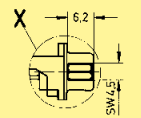

M3 or
4 - 40 UNC

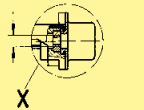

Board drillings

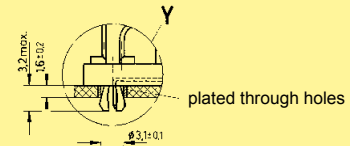
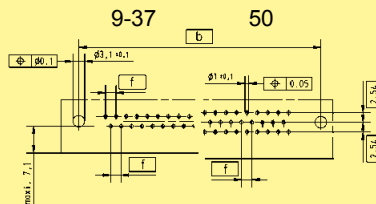

	a	b±0.1	c	f
9	30.90	25.00	12.50	2.74
15	39.20	33.30	12.50	2.74
25	53.10	47.00	12.50	2.76
37	69.40	63.50	12.50	2.76
50	67.00	61.10	15.70	2.76

Number of contacts

Mounting height

9-37
50

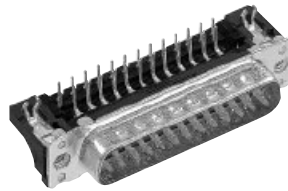
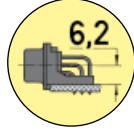
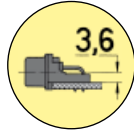

Low-Profile Versions

Stamped solder pins, angled with grounding board locks

D-Sub - S

Identification	No. of contacts	Part No.	
Performance levels Explanations see page 02.02 Other contact surfaces on request		Performance level 3	Performance level 2
Male connector metal shell with dimples	9 15 25 37	09 65 162 781 09 65 262 781 09 65 362 781 09 65 462 781	09 65 162 681 09 65 262 681 09 65 362 681 09 65 462 681
Female connector metal shell	9 15 25 37 50	09 66 152 761 09 66 252 761 09 66 352 761 09 66 452 761 09 66 552 761 ¹⁾	09 66 152 661 09 66 252 661 09 66 352 661 09 66 452 661 09 66 552 661 ¹⁾
Please insert digit for flange thread or fitted female screw locks			
M3 ▶ 5 4-40 UNC ▶ 6 fitted screw locks 4-40 UNC ▶ 7			

¹⁾ Not normally kept in stock

Number of contacts

Mounting height

9-37
50

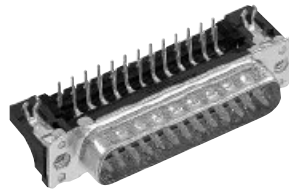
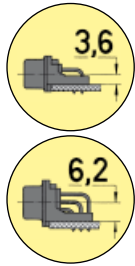

Low-Profile Versions

Stamped solder pins, angled with grounding board locks

Identification

Drawing

Dimensions in mm

Male connector

Mating face acc. to: DIN 41 652 · CECC 75 301-802
IEC 60 807

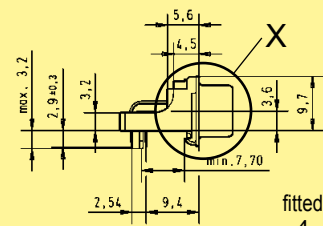
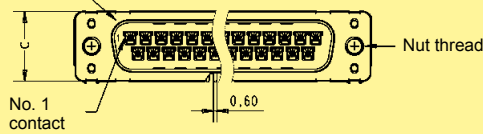

fitted screw locks
4 - 40 UNC

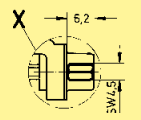

M3 or
4 - 40 UNC

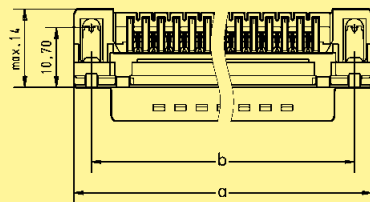
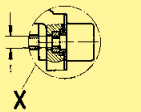

9-37 50

Female connector

Mating face acc. to: DIN 41 652 · CECC 75 301-802
IEC 60 807

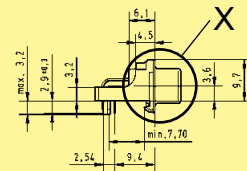
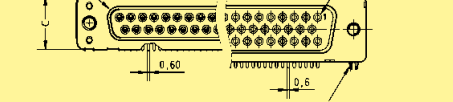

9-37

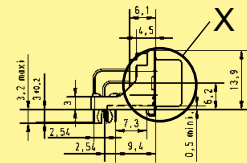
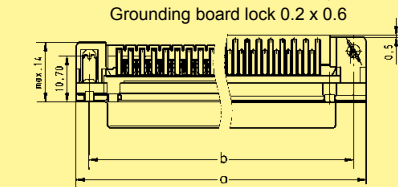

50

Board drillings

9-37 50

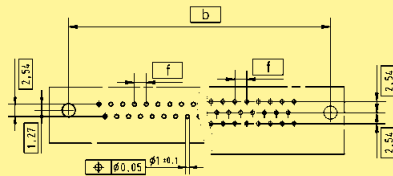

	a	b±0,1	c	f
9	30.90	25.00	12.50	2.74
15	39.20	33.30	12.50	2.74
25	53.10	47.00	12.50	2.76
37	69.40	63.50	12.50	2.76
50	67.00	61.10	15.40	2.76

U.S. Footprint

Number of contacts

Mounting height

9-37

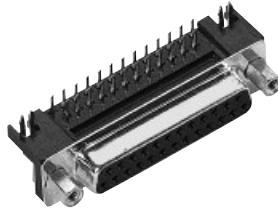
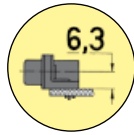

Stamped solder pins, angled with snap-in-clips and grounding board locks

D-Sub - S

Identification	No. of contacts	Part No.	
Performance levels Explanations see page 02.02 Other performance levels on request		Performance level 3	
		S4 ¹⁾	
Male connector metal shell with dimples		2.84 mm pitch	
	9	09 68 163 781	09 68 163 581
	15	09 68 263 781	09 68 263 581
	25	09 68 363 781	09 68 363 581
	37	09 68 463 781	09 68 463 581
Female connector metal shell		2.84 mm pitch	
	9	09 68 153 761	09 68 153 561
	15	09 68 253 761	09 68 253 561
	25	09 68 353 761	09 68 353 561
	37	09 68 453 761	09 68 453 561
Please insert digit for flange thread or fitted female screw locks			
M3 ▶ ¹²⁾			
4-40 UNC ▶ 2			
fitted screw locks 4-40 UNC ▶ 3			

¹⁾ S4 = 0.76 µm (30 µinch) Au or PdNi equivalent

²⁾ Not normally kept in stock

Number of contacts

9-37

Mounting height

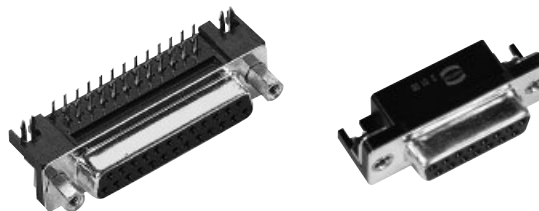
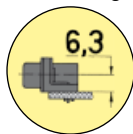

Stamped solder pins, angled with snap-in-clips and grounding board locks

Identification

Drawing

Dimensions in mm

Male connector

Mating face acc. to: DIN 41 652 · CECC 75 301-802
IEC 60 807

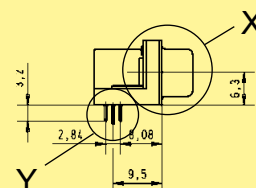
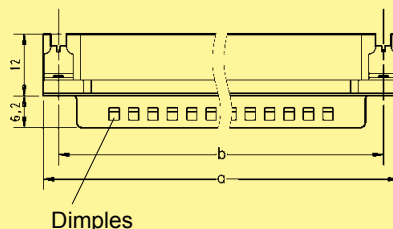
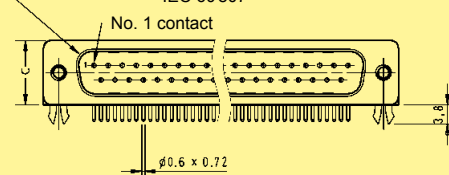

plated through holes

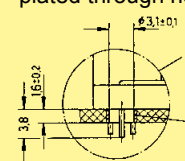

Female connector

Mating face acc. to: DIN 41 652 · CECC 75 301-802
IEC 60 807

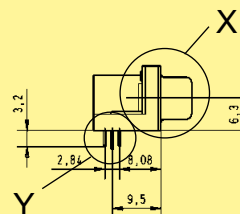
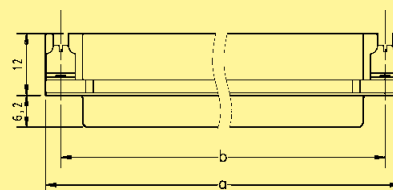
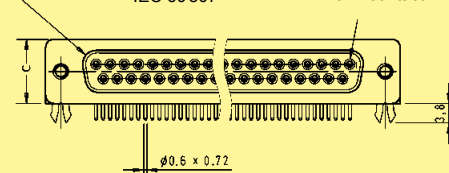

M3 or 4 - 40 UNC fitted screw locks
4 - 40 UNC

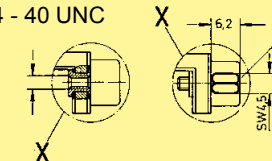

Board drillings

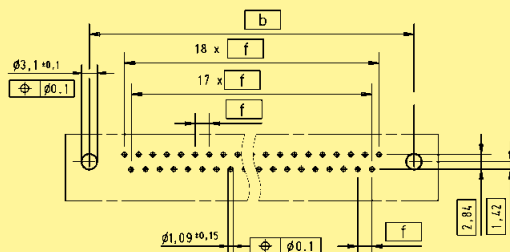

	a	b ± 0.1	c	f
9	30.90	25.00	12.55	2.77
15	39.20	33.30	12.55	2.77
25	53.10	47.00	12.55	2.77
37	69.40	63.50	12.55	2.77

Identification

Drawing

Dimensions in mm

Standard Versions

Mounting height 7.3 mm
9-37 way
for front panel
4 units of width (TE)

Mounting height 8.7 mm
50 way
for front panel
5 units of width (TE)

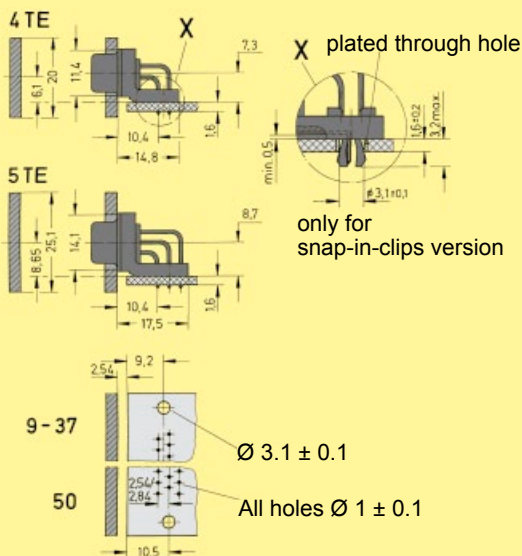

for connectors see pages 02.10 – 02.15

Low-Profile Versions

Mounting height 3.6 mm
9-37 way
for front panel
3 units of width (TE)

Mounting height 6.2 mm
50 way
for front panel
4 units of width (TE)

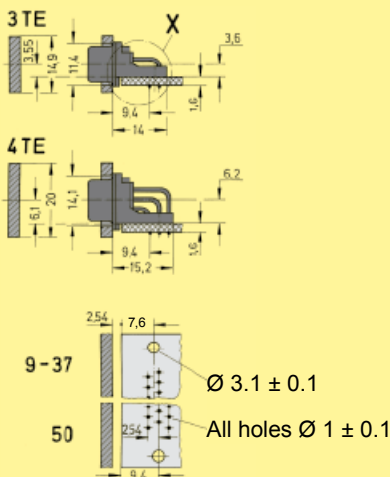

When used in a wave soldering process the mating face of the connector must be protected with adhesive tape.



for connectors see pages 02.16 – 02.19

U.S. Footprint Versions

Mounting height 6.3 mm
9-37 way
for front panel
4 units of width (TE)

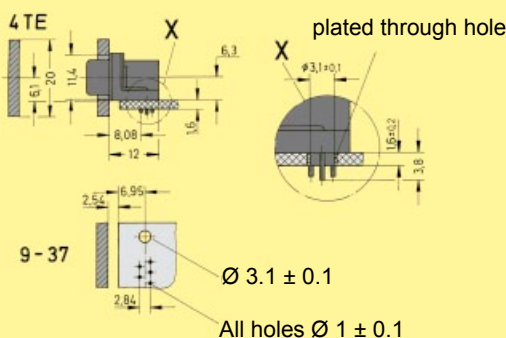

for connectors see pages 02.20 – 02.21

Panel cut out
for front/rear mount

Values are taken from the
CECC 75 301-802

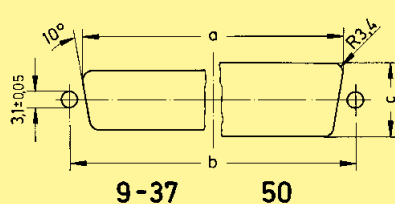

Front mount

Rear mount

	$a_{\pm 0.2}$	$b_{\pm 0.13}$	$c_{\pm 0.2}$		$a_{\pm 0.2}$	$b_{\pm 0.13}$	$c_{\pm 0.2}$
9	22.2	25.0	12.3	9	20.5	25.0	11.4
15	30.5	33.3	12.3	15	28.8	33.3	11.4
25	44.3	47.0	12.3	25	42.5	47.0	11.4
37	60.7	63.5	12.3	37	59.1	63.5	11.4
50	58.3	61.1	15.1	50	56.3	61.1	14.1

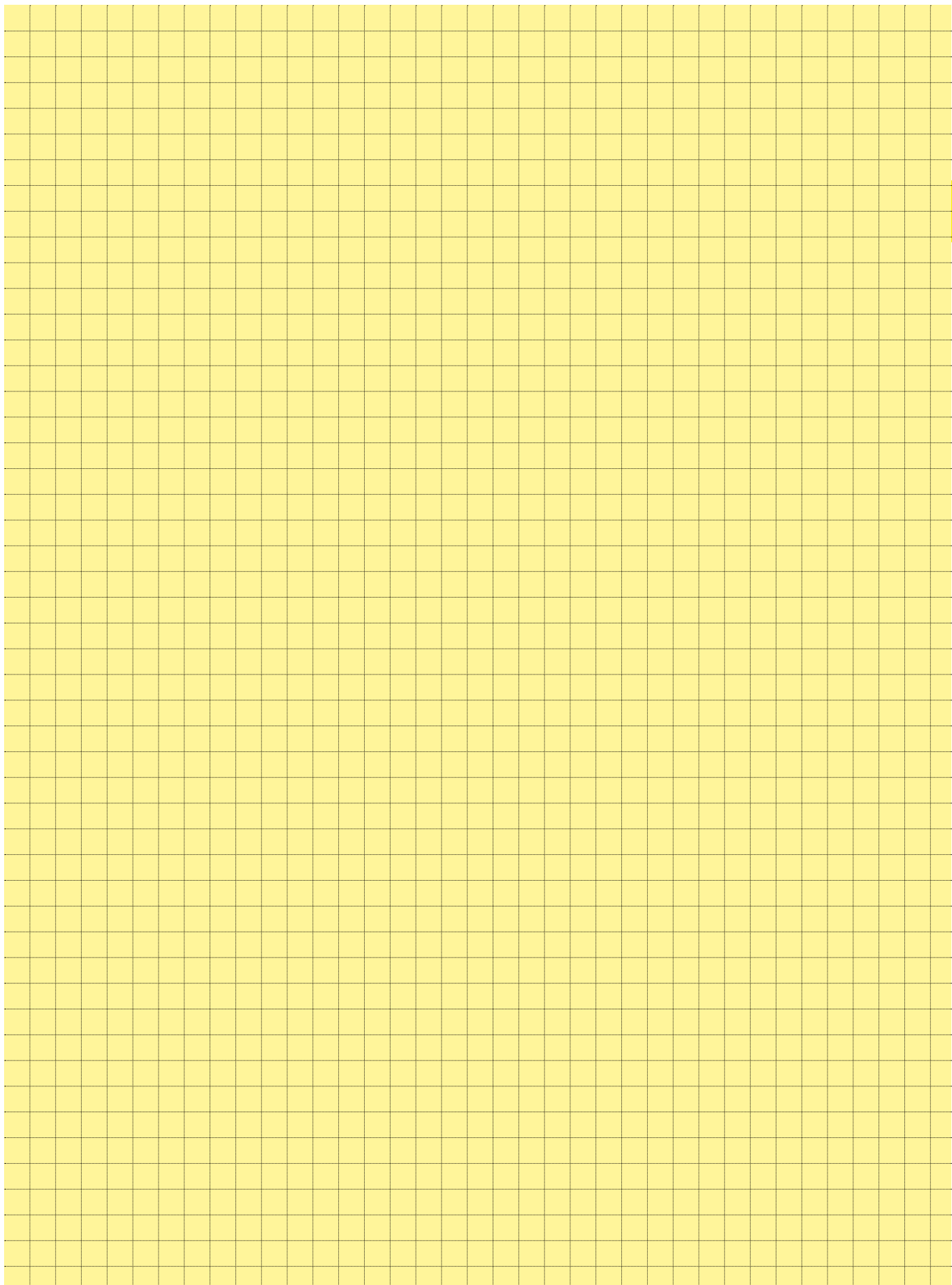

Number of contacts	9, 15, 25, 37, 50 UL recognized
Working current	see current carrying capacity chart Turned contacts 7.5 A max. Stamped contacts 6.5 A max. Insulation displacement 2 A max.
Test voltage $U_{r.m.s.}$	1 kV
Clearance and creepage	≥ 1.0 mm ≥ 0.7 mm (insulation displacement)
Contact resistance	≤ 10 m Ω
Insulation resistance	$\geq 10^{10}$ Ω
Temperature range	turned version -55 °C ... + 125 °C stamped solder -40 °C ... + 85 °C bucket version
Terminations	a) Solder buckets AWG 20 b) Stamped crimp contacts AWG 28-24 0.09-0.25 mm ² max. insulation \varnothing 1.02 mm AWG 24-20 0.25-0.56 mm ² max. insulation \varnothing 1.52 mm c) Turned crimp contacts AWG 22-18 0.33-0.82 mm ² AWG 24-20 0.25-0.52 mm ² AWG 26-22 0.13-0.33 mm ² AWG 28-24 0.09-0.25 mm ² max. insulation \varnothing 2.15 mm d) Insulation displacement AWG 28/7 and AWG 26/7 e) Wrap posts 0.6 x 0.6 mm diagonal 0.8-0.86 mm length 13 mm
Materials	Mouldings and hoods Thermoplastic resin, glass-fibre filled (PBTP), UL 94-V0 Contacts Copper alloy Contact surface Contact zone selectively plated according to performance level ¹⁾ Metal shell Plated steel
Mating force	9 way ≤ 30 N 15 way ≤ 50 N 25 way ≤ 83 N 37 way ≤ 123 N 50 way ≤ 167 N

Current carrying capacity

The current carrying capacity is limited by maximum temperature of materials for inserts and contacts including terminals. The current capacity-curve is valid for continuous, not interrupted current-loaded contacts of connectors when simultaneous power on all contacts is given, without exceeding the maximum temperature. Control and test procedures according to DIN IEC 60 512.

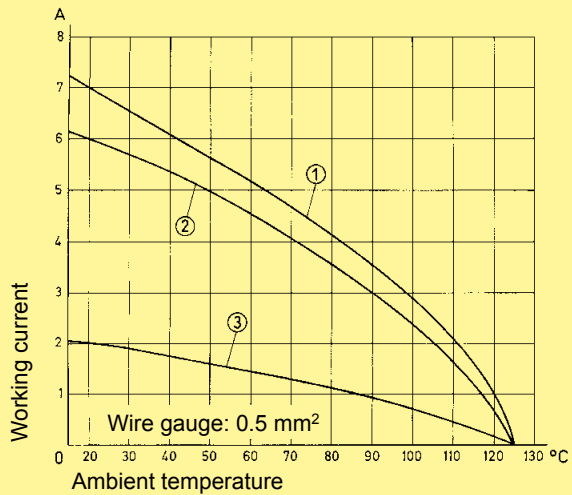

Example: 25 way connector
① Turned contacts
② Stamped contacts
③ Insulation displacement contacts

Contact arrangement View from termination side

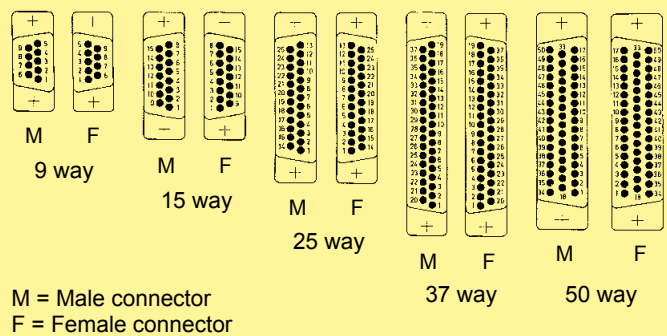

Mating conditions as per DIN 41 652

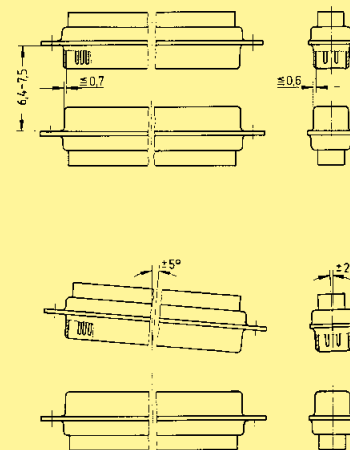

¹⁾ Performance level 3, 50 mating cycles, no gas test
Performance level 2 as per CECC 75 301-802, 250 mating cycles, 4 days 4 mixed gas test – IEC 60 512
Performance level 1 as per CECC 75 301-802, 500 mating cycles, 10 days 4 mixed gas test – IEC 60 512

Number of contacts

9-50



Turned wrap posts 0.6 x 0.6 mm

Identification	No. of contacts	Part No.	
Performance levels Explanations see page 02.24 Other performance levels on request		Performance level 3	Performance level 2
Male connector metal shell with dimples	9 15 25 37 50	09 67 009 5607 09 67 015 5607 09 67 025 5607 09 67 037 5607 09 67 050 5607	09 67 009 5616 ¹⁾ 09 67 015 5616 ¹⁾ 09 67 025 5616 ¹⁾ 09 67 037 5616 ¹⁾ 09 67 050 5616 ¹⁾
Female connector metal shell	9 15 25 37 50	09 67 009 4707 09 67 015 4707 09 67 025 4707 09 67 037 4707 09 67 050 4707	09 67 009 4716 ¹⁾ 09 67 015 4716 ¹⁾ 09 67 025 4716 ¹⁾ 09 67 037 4716 ¹⁾ 09 67 050 4716 ¹⁾

Male connector

Female connector

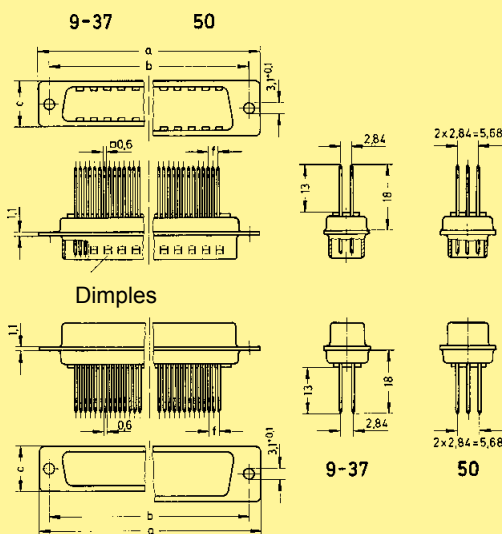

	a	b ± 0.1	c	f
9	30.9	25.0	12.5	2.74
15	39.2	33.3	12.5	2.74
25	53.1	47.0	12.5	2.76
37	69.4	63.5	12.5	2.76
50	67.0	61.1	15.4	2.76

Panel cut out for front/rear mount

Values are taken from the CECC 75 301-802

see page 02.22

Dimensions in mm

¹⁾ Not normally kept in stock

Mating conditions see page 02.24

Number of contacts

9-50

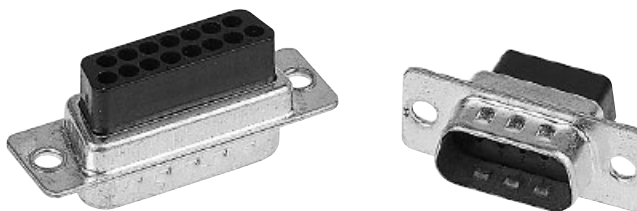

Crimp terminal

D-Sub - S

Identification	No. of contacts	Part No.
Male connector Order contacts separately metal shell with dimples	9	09 67 009 5601
	15	09 67 015 5601
	25	09 67 025 5601
	37	09 67 037 5601
	50	09 67 050 5601
Female connector Order contacts separately metal shell	9	09 67 009 4701
	15	09 67 015 4701
	25	09 67 025 4701
	37	09 67 037 4701
	50	09 67 050 4701

Male connector

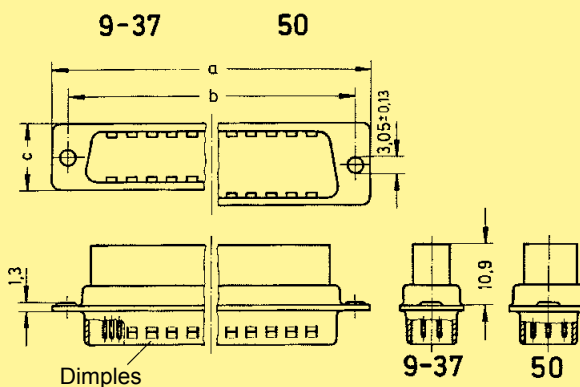

Female connector

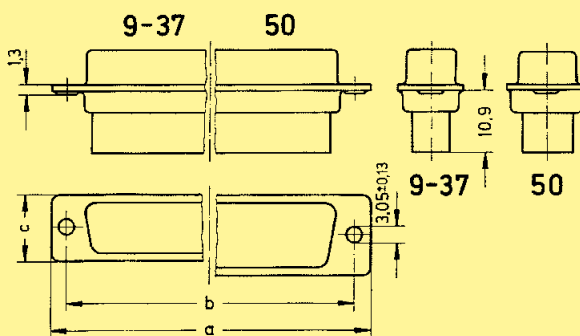

	a	b _{±0.1}	c
9	30.9	25.0	12.5
15	39.2	33.3	12.5
25	53.1	47.0	12.5
37	69.4	63.5	12.5
50	67.0	61.1	15.4

Panel cut out for front/rear mount

Values are taken from the CECC 75 301-802

see page 02.22

Dimensions in mm



Turned crimp contacts

Identification	Wire gauge (mm ²)	Part No.		
		Male contacts	Female contacts	High-end female contacts
		Performance level 1*	Performance level 1*	Performance level 1*
Individual contacts ¹⁾	AWG 22-18 0.33-0.82	09 67 000 3576	09 67 000 3476	09 67 000 3676
	AWG 24-20 0.25-0.52	09 67 000 8576	09 67 000 8476	09 67 000 8676
	AWG 26-22 0.13-0.33	09 67 000 5576	09 67 000 5476	09 67 000 5676
	AWG 28-24 0.09-0.25	09 67 000 7576	09 67 000 7476	09 67 000 7676

¹⁾ Minimum order 100 pieces or multiples of 100

Male contacts

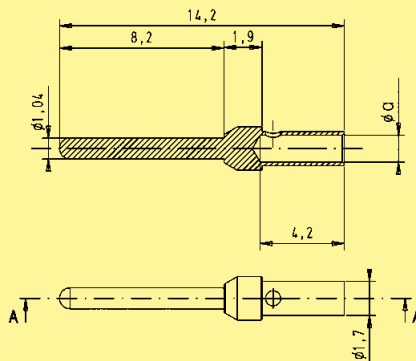

	a	groove
AWG 22-18	1.34	none
AWG 24-20	1.13	1
AWG 26-22	0.88	2
AWG 28-24	0.64	3

Female contacts

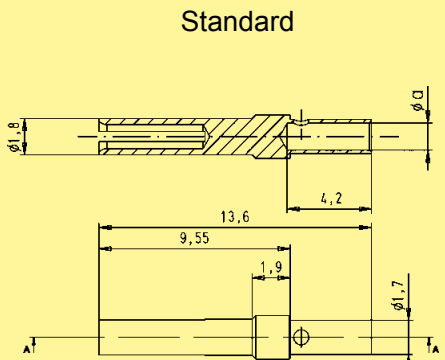

Standard

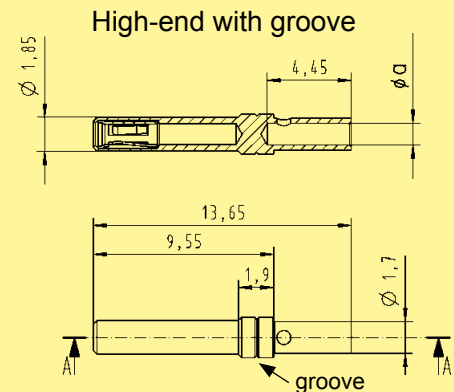

High-end with groove

* Performance level 1 as per CECC 75 301-802, 500 mating cycles, 10 days 4 mixed gas test – IEC 60 512
Use crimp tool with the part no. 09 99 000 0501 and the locator with the part no. 09 99 000 0531. Details see chapter 31

Stamped crimp contacts



D-Sub - S

Identification	Wire gauge (mm ²)	Part No.		
Performance levels Explanations see page 02.24 Other performance levels on request		stamped male contacts		
		Performance level 3	Performance level 2	Performance level 1
Individual contacts 500 pieces/reel Unrolling left 10 000 pieces/reel Unrolling left Unrolling left reversed Unrolling right reversed	AWG 28-24 0.09-0.25 stranded	09 67 000 7177 ¹⁾ 09 67 000 7167 09 67 000 7157 09 67 000 7147 09 67 000 7137	09 67 000 7178 ¹⁾ 09 67 000 7168 09 67 000 7158 09 67 000 7148 09 67 000 7138	09 67 000 7176 ¹⁾ 09 67 000 7166 09 67 000 7156 09 67 000 7146 09 67 000 7136
Individual contacts 500 pieces/reel Unrolling left 10 000 pieces/reel Unrolling left Unrolling left reversed Unrolling right reversed	AWG 24-20 0.25-0.56 stranded	09 67 000 8177 ¹⁾ 09 67 000 8167 09 67 000 8157 09 67 000 8147 09 67 000 8137	09 67 000 8178 ¹⁾ 09 67 000 8168 09 67 000 8158 09 67 000 8148 09 67 000 8138	09 67 000 8176 ¹⁾ 09 67 000 8166 09 67 000 8156 09 67 000 8146 09 67 000 8136
Unrolling direction				
		for HARTING tools		

¹⁾ Minimum order 500 pieces or multiples of 500
 Insertion and removal tool see chapter 31
 Contact dimensions see page 02.29

Stamped crimp contacts



Identification

Drawing

Dimensions in mm

Male contacts

For bandoliered contacts only

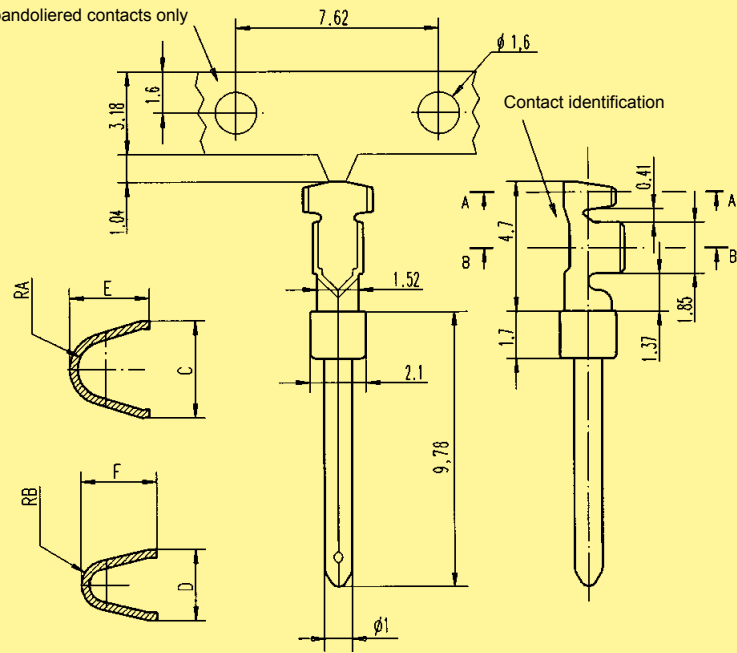

AWG	C	D	E	F	RA	RB	Contact identification
20-24	2.46	1.78	1.98	1.90	0.71	0.43	—
24-28	1.65	1.47	1.52	1.52	0.50	0.33	====

Stamped crimp contacts



D-Sub - S

Identification	Wire gauge (mm ²)	Part No.		
Performance levels Explanations see page 02.24 Other performance levels on request		stamped female contacts		
Individual contacts 500 pieces/reel Unrolling left 10 000 pieces/reel Unrolling left Unrolling left reversed Unrolling right reversed	AWG 28-24 0.09-0.25 stranded	Performance level 3	Performance level 2	Performance level 1
Individual contacts 500 pieces/reel Unrolling left 10 000 pieces/reel Unrolling left Unrolling left reversed Unrolling right reversed	AWG 24-20 0.25-0.56 stranded			
Unrolling direction		<p style="text-align: center;">for HARTING tools</p>		

¹⁾ Minimum order 500 pieces or multiples of 500
 Insertion and removal tool see chapter 31
 Contact dimensions see page 02.31

Stamped
crimp contacts



Identification

Drawing

Dimensions in mm

Female contacts

For banded contacts only

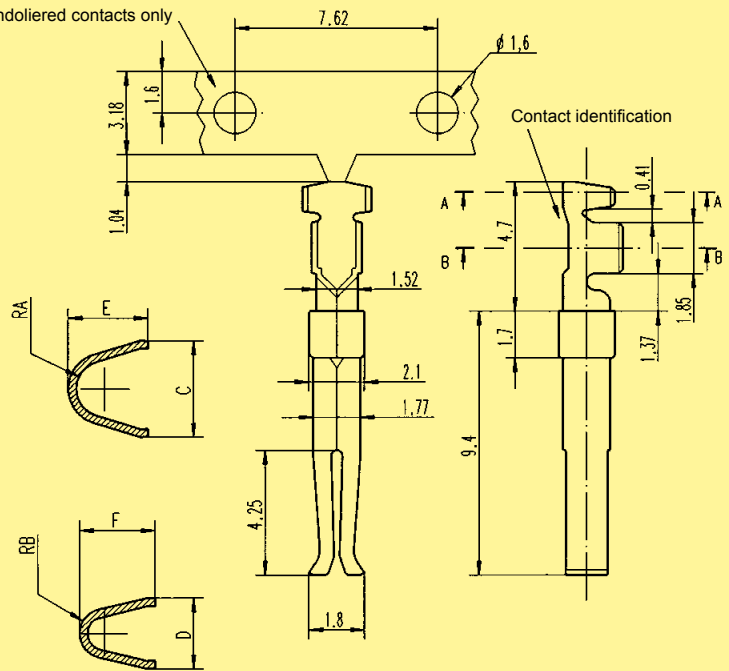

AWG	C	D	E	F	RA	RB	Contact identification
20-24	2.46	1.78	1.98	1.90	0.71	0.43	—
24-28	1.65	1.47	1.52	1.52	0.50	0.33	====

Number of contacts

9-37

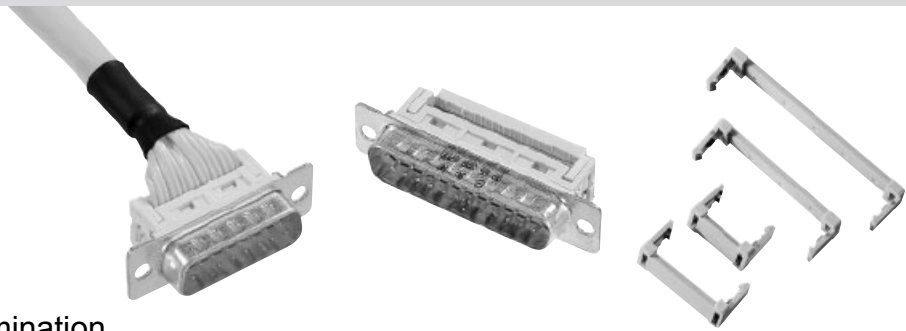

Insulation displacement termination

D-Sub - S

Identification	No. of contacts	Part No.	
Performance levels Explanations see page 02.24 Other performance levels on request		Performance level 3	
		Performance level 2	
Male connector²⁾ pitch 1.27 mm metal shell with dimples	9 15 25 37	09 66 128 770 09 66 228 770 09 66 328 770 09 66 428 770	09 66 128 670 09 66 228 670 09 66 328 670 09 66 428 670
Female connector²⁾ pitch 1.27 mm metal shell	9 15 25 37	09 66 118 750 09 66 218 750 09 66 318 750 09 66 418 750	09 66 118 650 09 66 218 650 09 66 318 650 09 66 418 650
Please insert digit for flange thread			
ø 3.1 mm hole ▶ 0 M3 ▶ 1 ¹⁾ 4-40 UNC ▶ 2			
Strain relief clamp plastic for male and female connector	9 15 25 37	09 66 108 0001 09 66 208 0001 09 66 308 0001 09 66 408 0001	09 66 108 0001 09 66 208 0001 09 66 308 0001 09 66 408 0001

¹⁾ Not normally kept in stock
²⁾ Not released for halogen free flat cables

Number of contacts

9-37

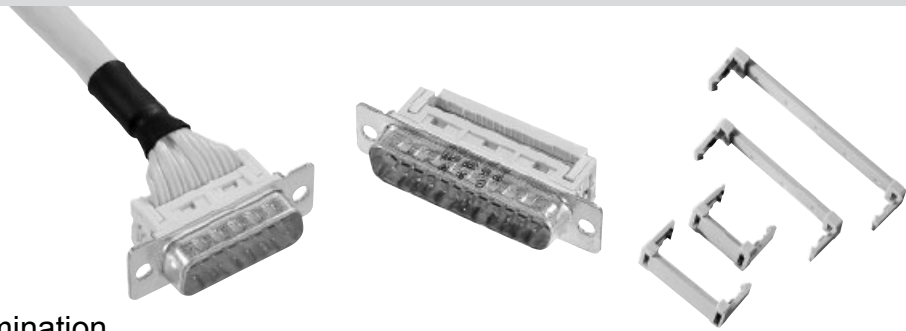

Insulation displacement termination

Identification

Drawing

Dimensions in mm

Male connector

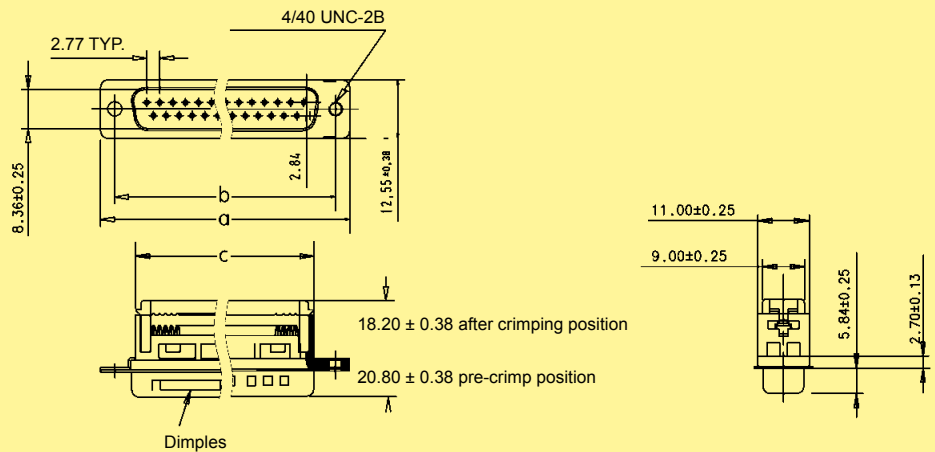

Female connector

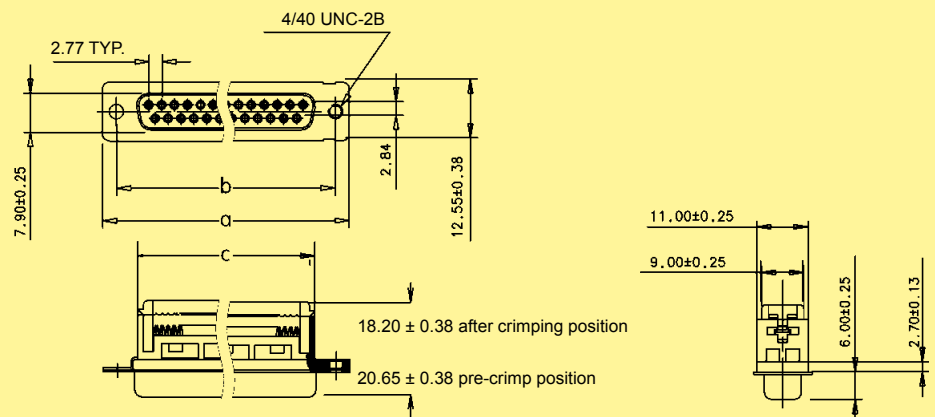

Male and female connectors

	a	b±0.1	c
9	30.80	24.99	16.10
15	39.10	33.32	24.00
25	53.09	47.04	38.14
37	69.40	63.50	54.60

Specified conductors
stranded wires – AWG 28/7
– AWG 26/7

Strain relief clamps

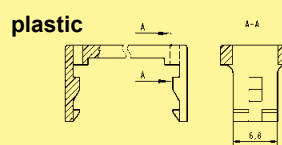

Panel cut out for front/rear mount

Values are taken from the CECC 75 301-802

see page 02.22

Number of contacts

9–50

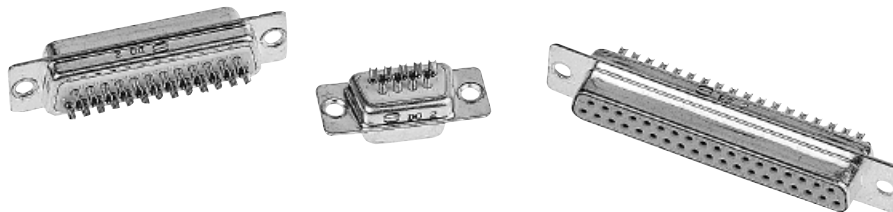

Solder buckets

D-Sub - S

Identification	No. of contacts	Part No.		
Performance levels Explanations see page 02.24 Other performance levels on request		Performance level 3	Performance level 2	
Male connector metal shell with dimples		turned contacts	turned contacts	
	9	09 67 009 5604	09 67 009 5615	
	15	09 67 015 5604	09 67 015 5615	
	25	09 67 025 5604	09 67 025 5615	
	37	09 67 037 5604	09 67 037 5615	
	50	09 67 050 5604	09 67 050 5615	
		stamped contacts	stamped contacts	
	9	09 67 209 5604	09 67 209 5615	
	15	09 67 215 5604	09 67 215 5615	
	25	09 67 225 5604	09 67 225 5615	
	37	09 67 237 5604	09 67 237 5615	
	50	09 67 250 5604	09 67 250 5615	
	Female connector metal shell		turned contacts	turned contacts
		9	09 67 009 4704	09 67 009 4715
15		09 67 015 4704	09 67 015 4715	
25		09 67 025 4704	09 67 025 4715	
37		09 67 037 4704	09 67 037 4715	
50		09 67 050 4704	09 67 050 4715	
		stamped contacts	stamped contacts	
9		09 67 209 4704	09 67 209 4715	
15		09 67 215 4704	09 67 215 4715	
25		09 67 225 4704	09 67 225 4715	
37		09 67 237 4704	09 67 237 4715	
50		09 67 250 4704	09 67 250 4715	

¹⁾ Not normally kept in stock

Number of contacts

9-50



Solder buckets

Identification

Drawing

Dimensions in mm

Male connector

9-37

50

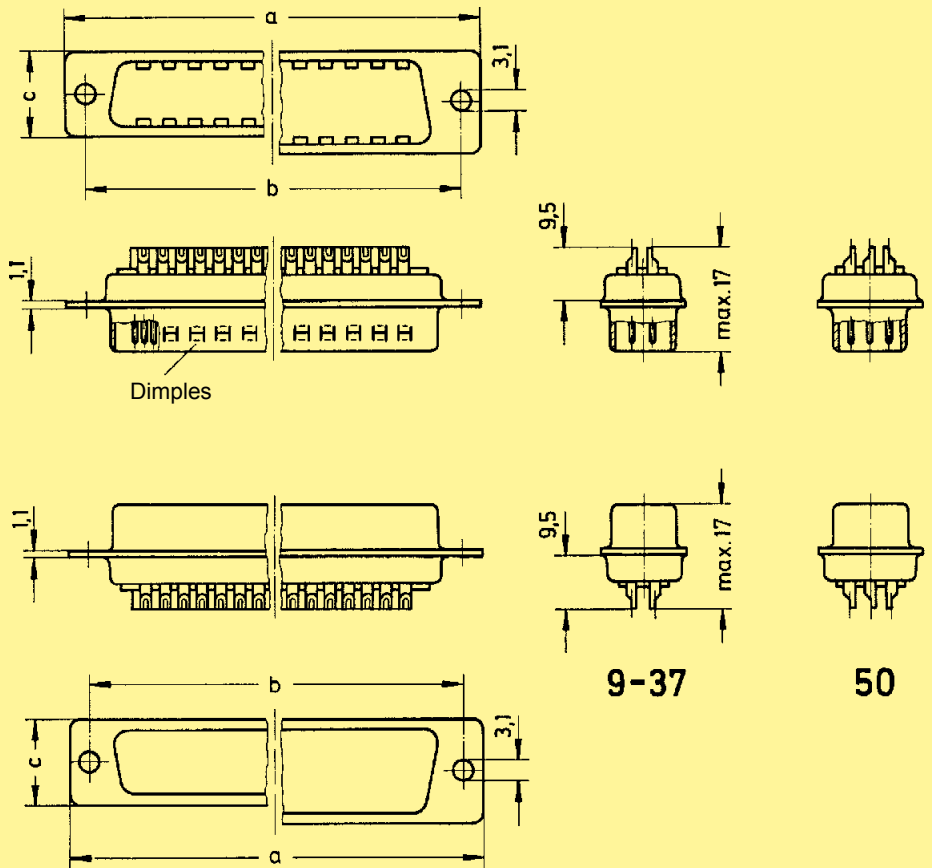

Female connector

9-37

50

	a	b _{±0.1}	c
9	30.9	25.0	12.5
15	39.2	33.3	12.5
25	53.1	47.0	12.5
37	69.4	63.5	12.5
50	67.0	61.1	15.4

Panel cut out
for front/rear mount

Values are taken from the
CECC 75 301-802



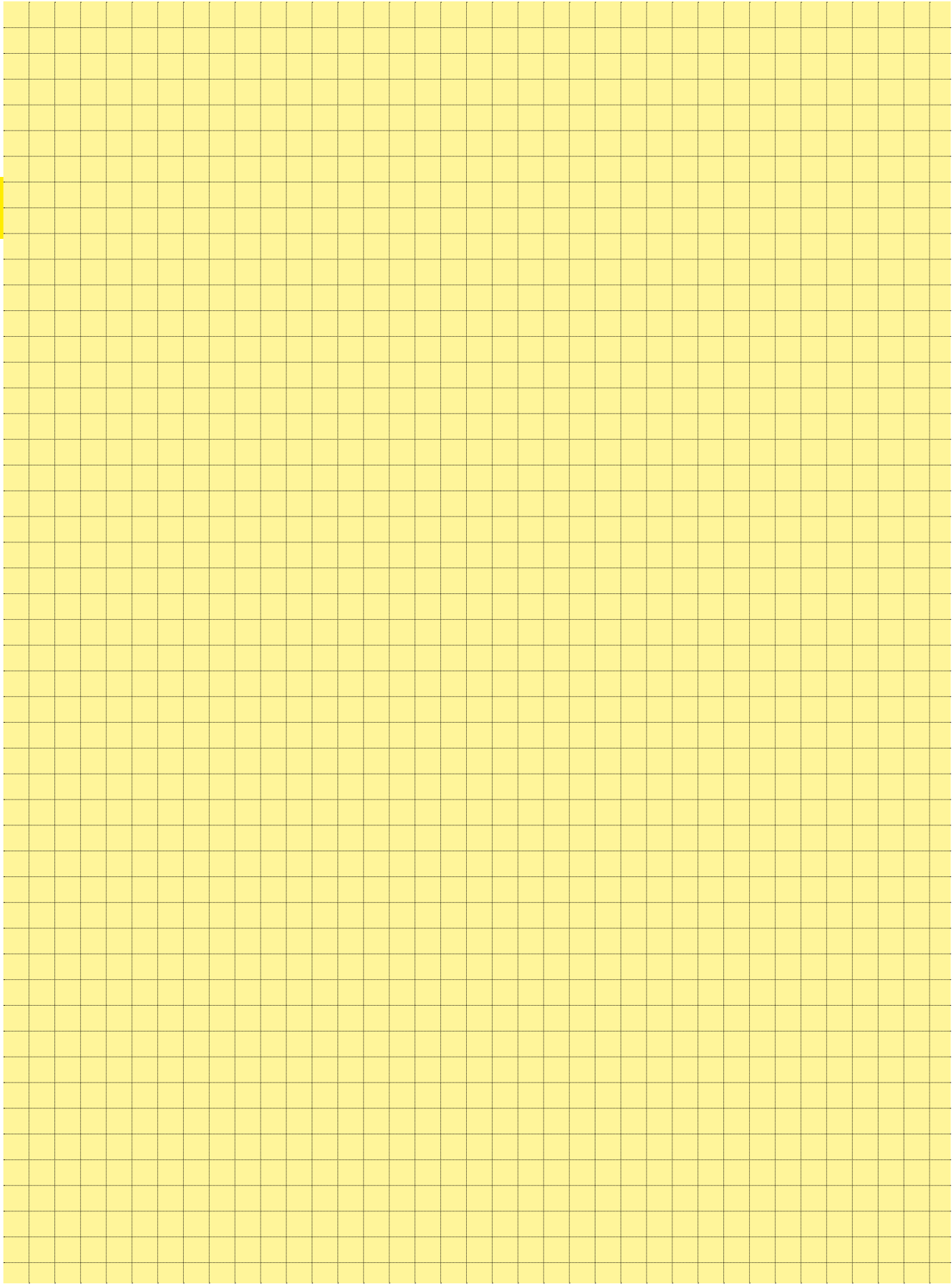

see page 02.22

D-Sub - S



D-Sub – High Density subminiature D connectors

Page

Technical characteristics		03.02
Connectors with crimp terminal / crimp contacts		03.03
Connectors with straight solder cups		03.06
Connectors with angled solder pins		03.08
Connectors with straight solder pins		03.11
Cables and cable assemblies		see chapter 40

D-Sub- HD

D-Sub - HD

Number of contacts	15, 26, 44, 62, 78
Working current Stamped contacts	2 A max.
Test voltage $U_{r.m.s.}$	1 kV
Clearance and creepage	≥ 1.0 mm
Contact resistance	< 20 m Ω
Insulation resistance	< 25 m Ω (for right angled versions) $\geq 5 \times 10^9$ Ω
Temperature range	-40 °C ... + 85 °C The higher temperature limit includes the local ambient and heating effect of the contacts under load
Terminations	a) Solder pins \varnothing 0.65 mm for P.C.B. holes \varnothing 1.0 mm b) Crimp contacts AWG 26 - 24 0.14 - 0.22 mm ² max. insulation \varnothing 1.38 mm c) Solder cups AWG 24
Materials	
Mouldings and hoods	Thermoplastic resin, glass-fibre filled (PBTP), UL 94-V0
Contacts	Copper alloy
Contact surface	
Contact zone	selectively plated according to performance level ¹⁾
Metal shell	Plated steel
Mating force	
	15 way ≤ 46 N
	26 way ≤ 77 N
	44 way ≤ 127 N
	62 way ≤ 177 N
	78 way ≤ 222 N

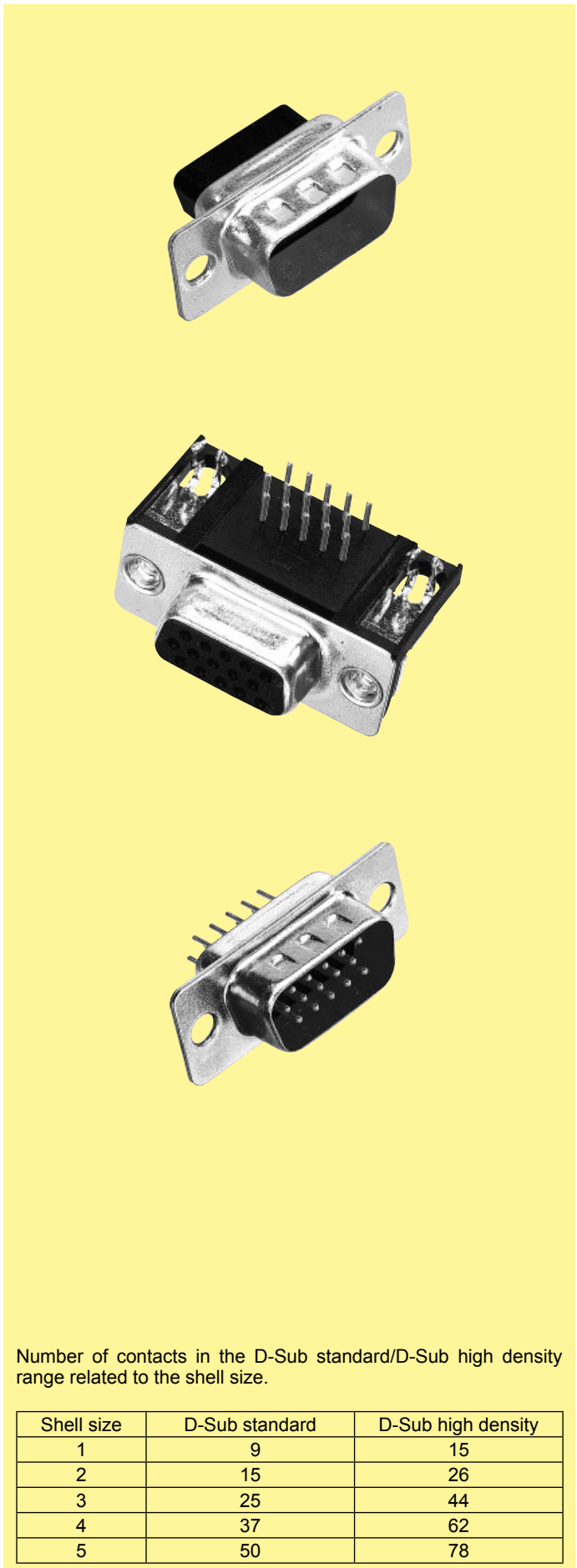

Number of contacts in the D-Sub standard/D-Sub high density range related to the shell size.

Shell size	D-Sub standard	D-Sub high density
1	9	15
2	15	26
3	25	44
4	37	62
5	50	78

¹⁾ Performance level 3, 50 mating cycles, no gas test
S4, plating = 0.76 μ m (30 μ inch) Au or PdNi equivalent

Number of contacts

15-78

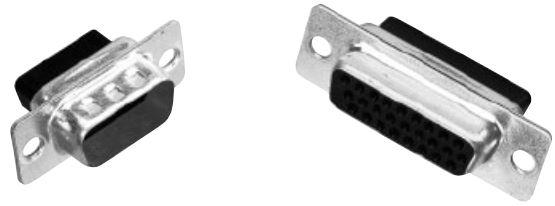

High density crimp terminal

Identification	No. of contacts	Part No.
Male connector Order contacts separately metal shell with dimples	15	09 56 100 5601
	26	09 56 200 5601
	44	09 56 300 5601
	62	09 56 400 5601
	78	09 56 500 5601
Female connector Order contacts separately metal shell	15	09 56 100 4701
	26	09 56 200 4701
	44	09 56 300 4701
	62	09 56 400 4701
	78	09 56 500 4701

D-Sub- HD

Male connector

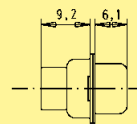
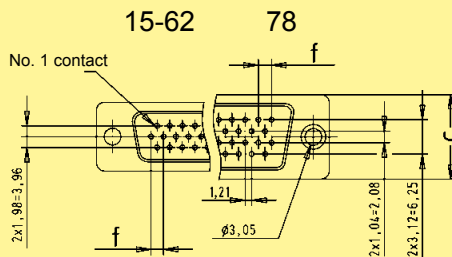

	a	b	c	f
15	30.9	25.0	12.5	2.29
26	39.2	33.3	12.5	2.29
44	53.1	47.0	12.5	2.29
62	69.4	63.5	12.5	2.41
78	67.0	61.1	15.4	2.41

Female connector

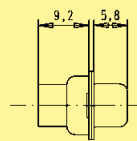
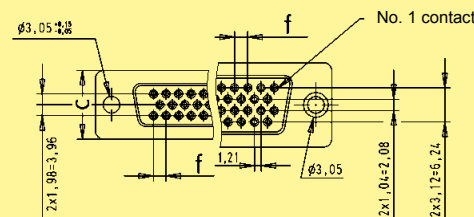

Panel cut out for front/rear mount

Values are taken from the CECC 75 301-802

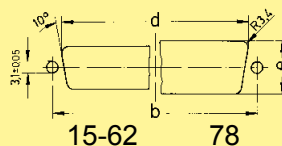

Front mount

	b±0.13	d±0.2	e±0.2
15	25.0	22.2	12.3
26	33.3	30.5	12.3
44	47.0	44.3	12.3
62	63.5	60.7	12.3
78	61.1	58.3	15.1

Rear mount

	b±0.13	d±0.2	e±0.2
15	25.0	20.5	11.4
26	33.3	28.8	11.4
44	47.0	42.5	11.4
62	63.5	59.1	11.4
78	61.1	56.3	14.1

Dimensions in mm

Crimp contacts for high density connectors

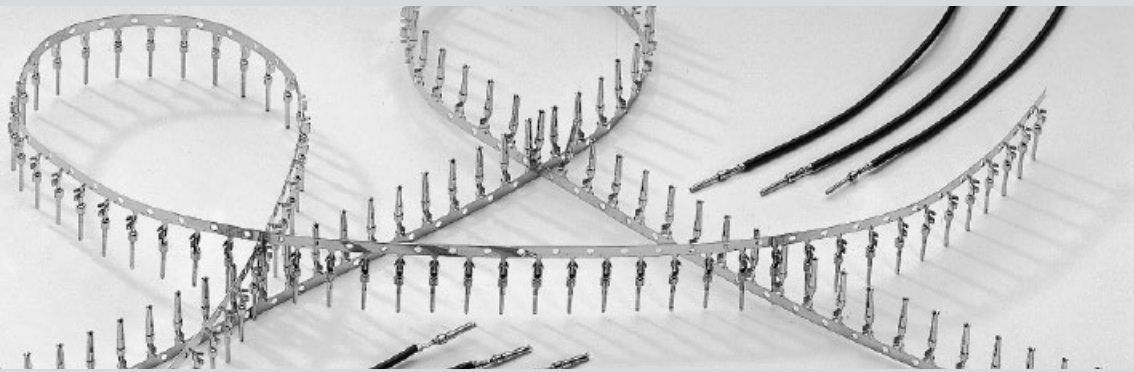

D-Sub - HD

Identification	Wire gauge (mm ²)	Part No.			
		stamped male contacts		stamped female contacts	
Performance levels Explanations see page 03.02 Other performance levels on request		Performance level 3	S4 ¹⁾	Performance level 3	S4 ¹⁾
500 pieces/box	AWG 26-24 0.14-0.22 stranded	09 56 000 8177	09 56 000 8175	09 56 000 8277	09 56 000 8275
500 pieces/reel Unrolling left		09 56 000 8167	09 56 000 8165	09 56 000 8267	09 56 000 8265
10 000 pieces/reel Unrolling left		09 56 000 8157	09 56 000 8155	09 56 000 8257	09 56 000 8255
Unrolling direction		<p>500 pieces/reel Unrolling left 10 000 pieces/reel Unrolling left</p> <p>for HARTING tools</p>			

¹⁾ S4 = 0.76 µm (30 µinch) Au or PdNi equivalent
Contact dimensions see page 03.05

Crimp contacts for high density connectors

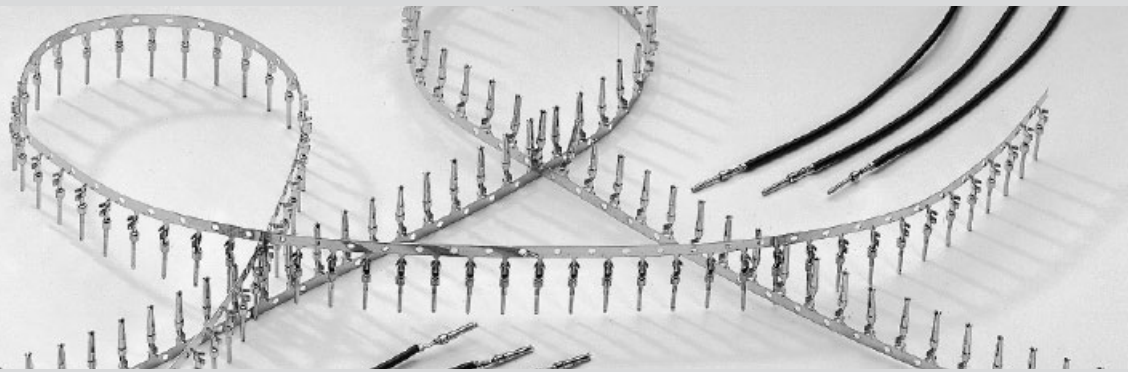

Identification

Drawing

Dimensions in mm

Male contacts

wire gauge AWG 26-24

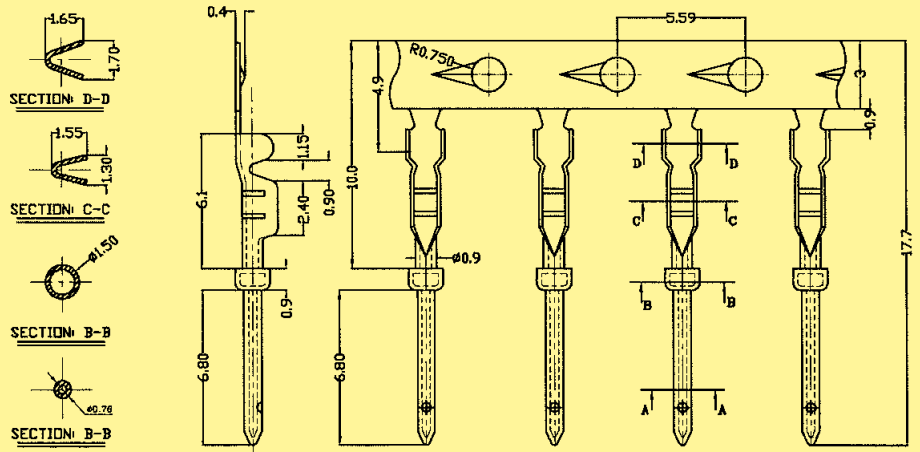

Female contacts

wire gauge AWG 26-24

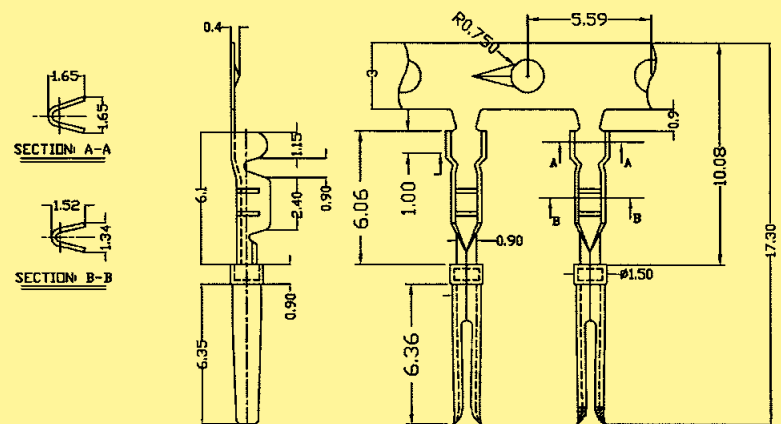

Number of contacts

15–78



High density with stamped solder cups, straight

D-Sub - HD

Identification	No. of contacts	Part No.	
Performance levels Explanations see page 03.02 Other performance levels on request		Performance level 3	S4¹⁾
Male connector metal shell with dimples			
Female connector metal shell			
	15 26 44 62 78	09 56 100 5604 09 56 200 5604 09 56 300 5604 09 56 400 5604 09 56 500 5604	09 56 100 5615 050 09 56 200 5615 050 09 56 300 5615 050 09 56 400 5615 050 09 56 500 5615 050
	15 26 44 62 78	09 56 100 4704 09 56 200 4704 09 56 300 4704 09 56 400 4704 09 56 500 4704	09 56 100 4715 050 09 56 200 4715 050 09 56 300 4715 050 09 56 400 4715 050 09 56 500 4715 050

¹⁾ S4 = 0.76 µm (30 µinch) Au or PdNi equivalent

Number of contacts

15-78



High density with stamped solder cups, straight

Identification

Drawing

Dimensions in mm

Male connector

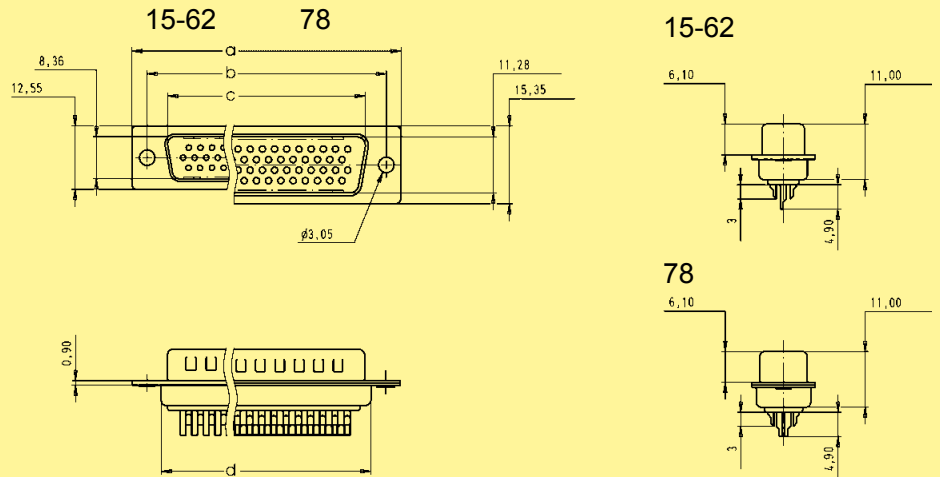

	a	b	c	d	e
15	30.81	25.00	16.92	19.20	16.33
26	39.20	33.30	25.25	27.70	24.70
44	53.05	47.00	38.96	41.10	38.40
62	69.40	63.50	55.42	57.30	54.80
78	67.00	61.00	52.81	55.10	52.20

Female connector

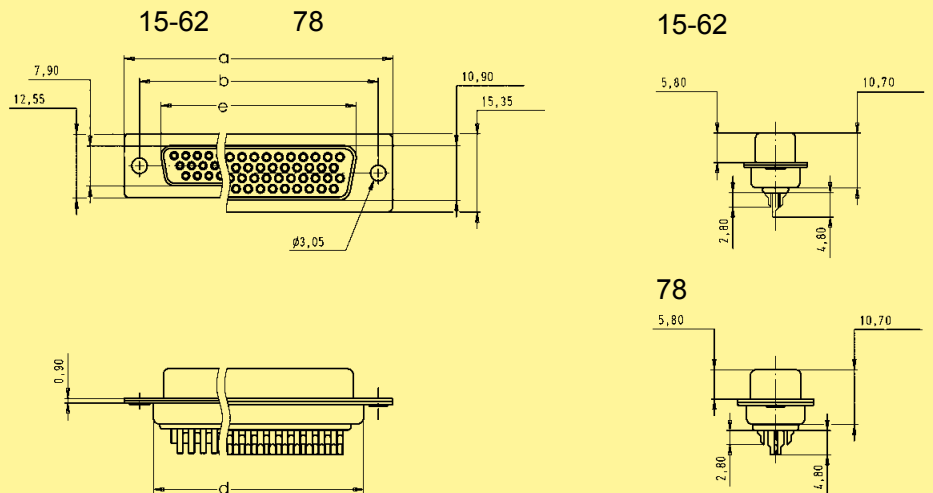

Number of contacts

15-78

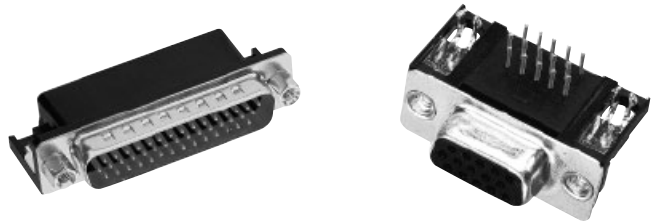

High density with stamped solder pins, angled with grounding board locks

D-Sub - HD

Identification	No. of contacts	Part No.	
Performance levels Explanations see page 03.02 Other performance levels on request		Performance level 3	
		S4 ¹⁾	
Male connector metal shell with dimples			
	15	09 56 162 781 .	09 56 162 581 .
	26	09 56 262 781 .	09 56 262 581 .
	44	09 56 362 781 .	09 56 362 581 .
	62	09 56 462 781 .	09 56 462 581 .
	78	09 56 562 781 .	09 56 562 581 .
Female connector metal shell			
	15	09 56 152 761 .	09 56 152 561 .
	26	09 56 252 761 .	09 56 252 561 .
	44	09 56 352 761 .	09 56 352 561 .
	62	09 56 452 761 .	09 56 452 561 .
	78	09 56 552 761 .	09 56 552 561 .
Please insert digit for flange thread or fitted female screw locks			
4-40 UNC ▶ 2			
fitted screw locks 4-40 UNC ▶ 3			

¹⁾ S4 = 0.76 µm (30 µinch) Au or PdNi equivalent

Number of contacts

15-78

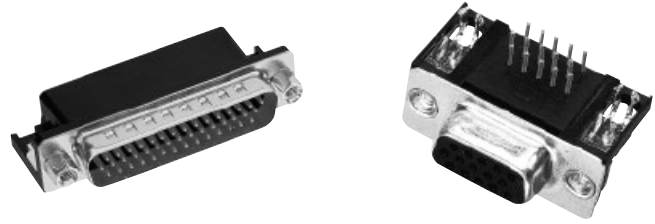

High density with stamped solder pins, angled with grounding board locks

Identification

Drawing

Dimensions in mm

Male connector

15-62 78

15-62

78

No. 1 contact

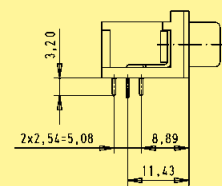
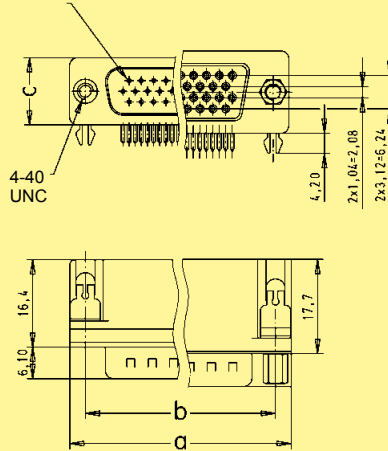

4-40 UNC

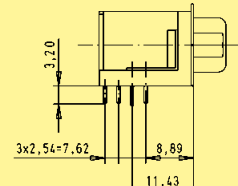

fitted screw locks
4-40 UNC

	a	b _{±0.1}	c
15	30.81	24.99	12.55
26	39.20	33.30	12.55
44	53.05	47.04	12.55
62	69.40	63.50	12.55
78	67.00	61.00	15.37

Female connector

15-62 78

15-62

78

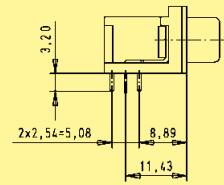
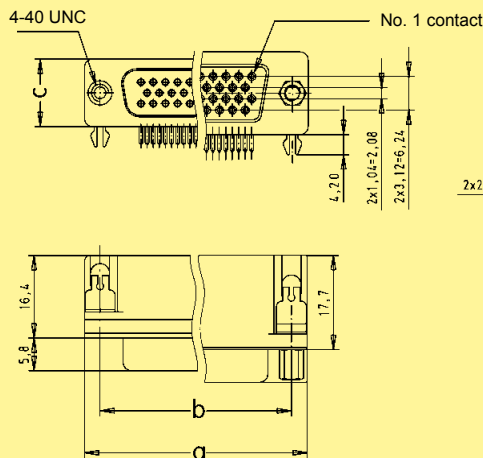

4-40 UNC

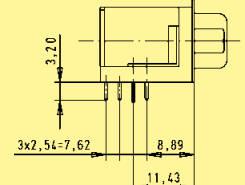

fitted screw locks
4-40 UNC

Number of contacts

15-78

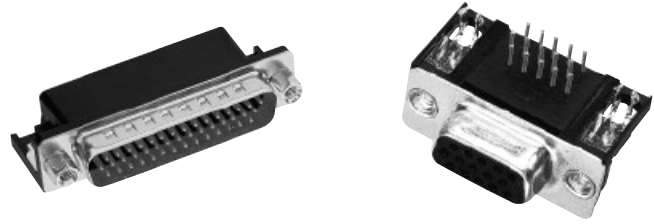

High density with stamped solder pins, angled with grounding board locks

Identification

Drawing

Dimensions in mm

Board drillings

male 15

female 15

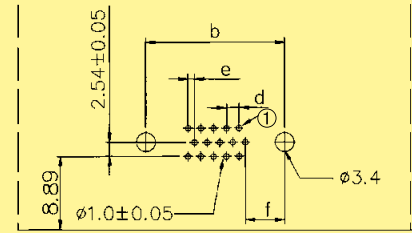
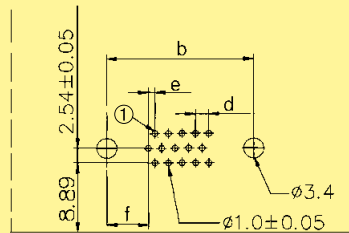

male 26-62

female 26-62

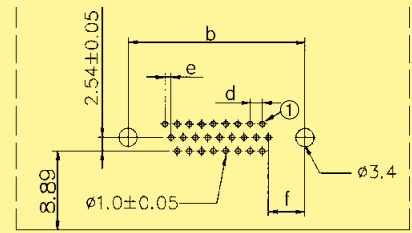
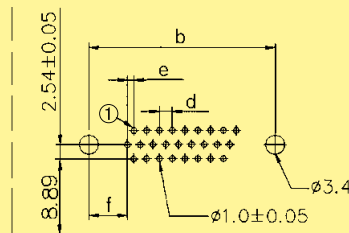

male 78

female 78

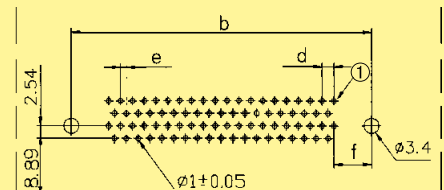
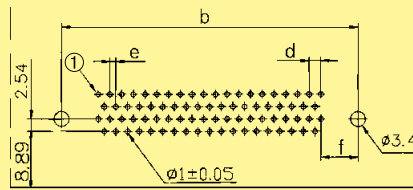

① = No. 1 contact

	$b_{\pm 0.1}$	d	e	f
15	24.99	2.29	1.145	7.04
26	33.30	2.29	1.145	6.88
44	47.04	2.29	1.145	6.88
62	63.50	2.41	1.205	7.00
78	61.00	2.41	1.205	7.65

D-Sub - HD

Number of contacts

15-78

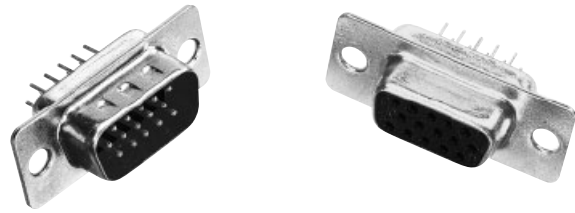

High density with stamped solder pins, straight

Identification	No. of contacts	Part No.	
Performance levels Explanations see page 03.02 Other performance levels on request		Performance level 3	S4¹⁾
Male connector metal shell with dimples	15 26 44 62 78	09 56 161 7700 09 56 261 7700 09 56 361 7700 09 56 461 7700 09 56 561 7700	09 56 161 5700 09 56 261 5700 09 56 361 5700 09 56 461 5700 09 56 561 5700
Female connector metal shell	15 26 44 62 78	09 56 151 7500 09 56 251 7500 09 56 351 7500 09 56 451 7500 09 56 551 7500	09 56 151 5500 09 56 251 5500 09 56 351 5500 09 56 451 5500 09 56 551 5500

D-Sub- HD

Male connector

15-62 78 15-62 78

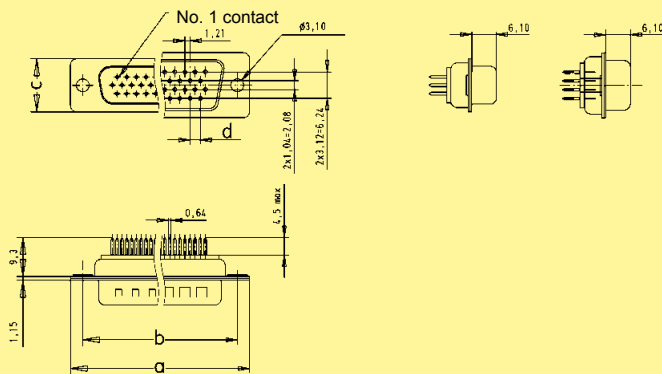

Female connector

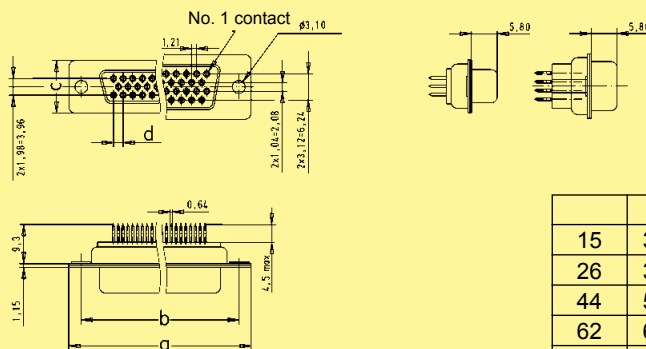

	a	b _{±0.1}	c	d
15	30.9	25.0	12.5	2.29
26	39.2	33.3	12.5	2.29
44	53.1	47.0	12.5	2.29
62	69.4	63.5	12.5	2.41
78	67.0	61.1	15.4	2.41

Board drillings

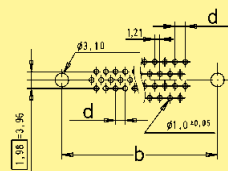

Dimensions in mm

¹⁾ S4 = 0.76 µm (30 µinch) Au or PdNi equivalent

Number of contacts

15–78

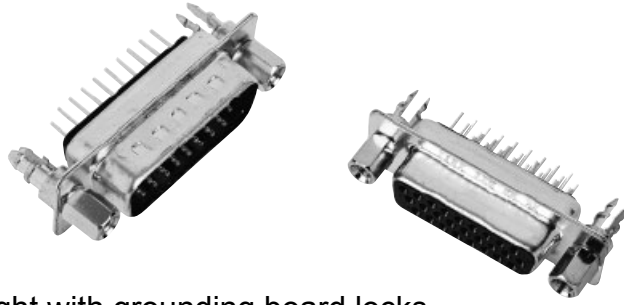

High density with stamped solder pins, straight with grounding board locks

D-Sub - HD

Identification	No. of contacts	Part No.		
Performance levels Explanations see page 03.02 Other performance levels on request		Performance level 3		S4 ¹⁾
Male connector metal shell with dimples				
Female connector metal shell				
Please insert digit for flange thread or fitted female screw locks 4-40 UNC ▶ 2 fitted screw locks 4-40 UNC ▶ 3				

15	09 56 161 771 .	09 56 161 571 .
26	09 56 261 771 .	09 56 261 571 .
44	09 56 361 771 .	09 56 361 571 .
62	09 56 461 771 .	09 56 461 571 .
78	09 56 561 771 .	09 56 561 571 .

15	09 56 151 751 .	09 56 151 551 .
26	09 56 251 751 .	09 56 251 551 .
44	09 56 351 751 .	09 56 351 551 .
62	09 56 451 751 .	09 56 451 551 .
78	09 56 551 751 .	09 56 551 551 .

¹⁾ S4 = 0.76 µm (30 µinch) Au or PdNi equivalent

Number of contacts

15-78

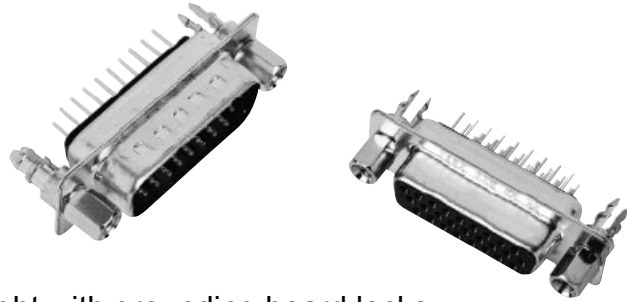

High density with stamped solder pins, straight with grounding board locks

Identification

Drawing

Dimensions in mm

Male connector

15-62 78

15-62 78

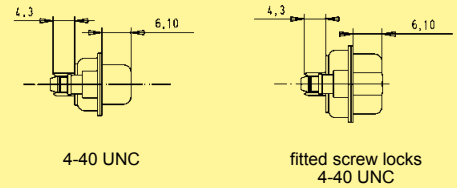
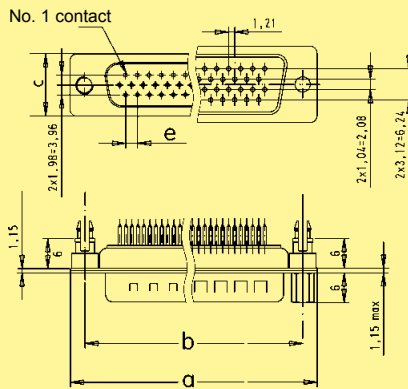

	a	b $\pm 0,1$	c	e
15	30.9	25.0	12.5	2.29
26	39.2	33.3	12.5	2.29
44	53.1	47.0	12.5	2.29
62	69.4	63.5	12.5	2.41
78	67.0	61.1	15.4	2.41

Female connector

15-62 78

15-62 78

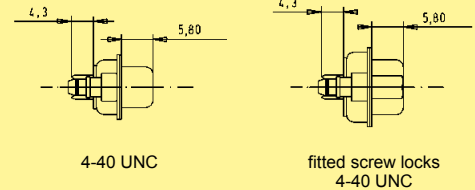
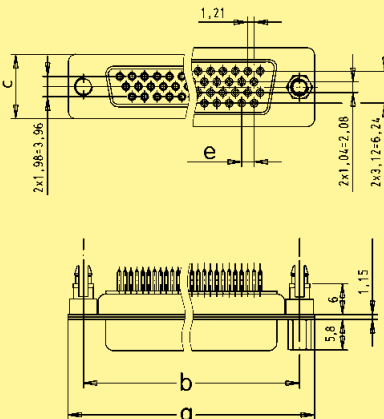

Board drillings

male 15-62

female 15-62

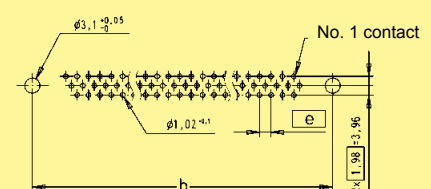
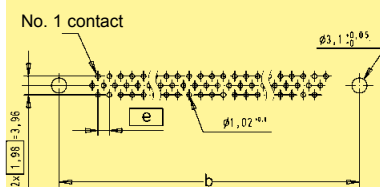

male 78



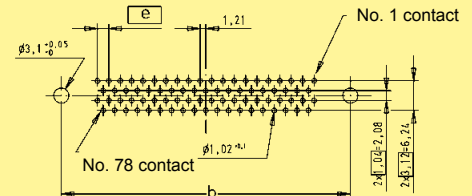
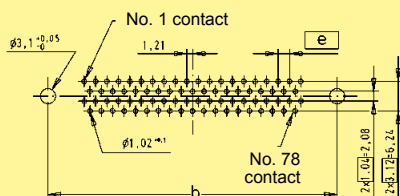

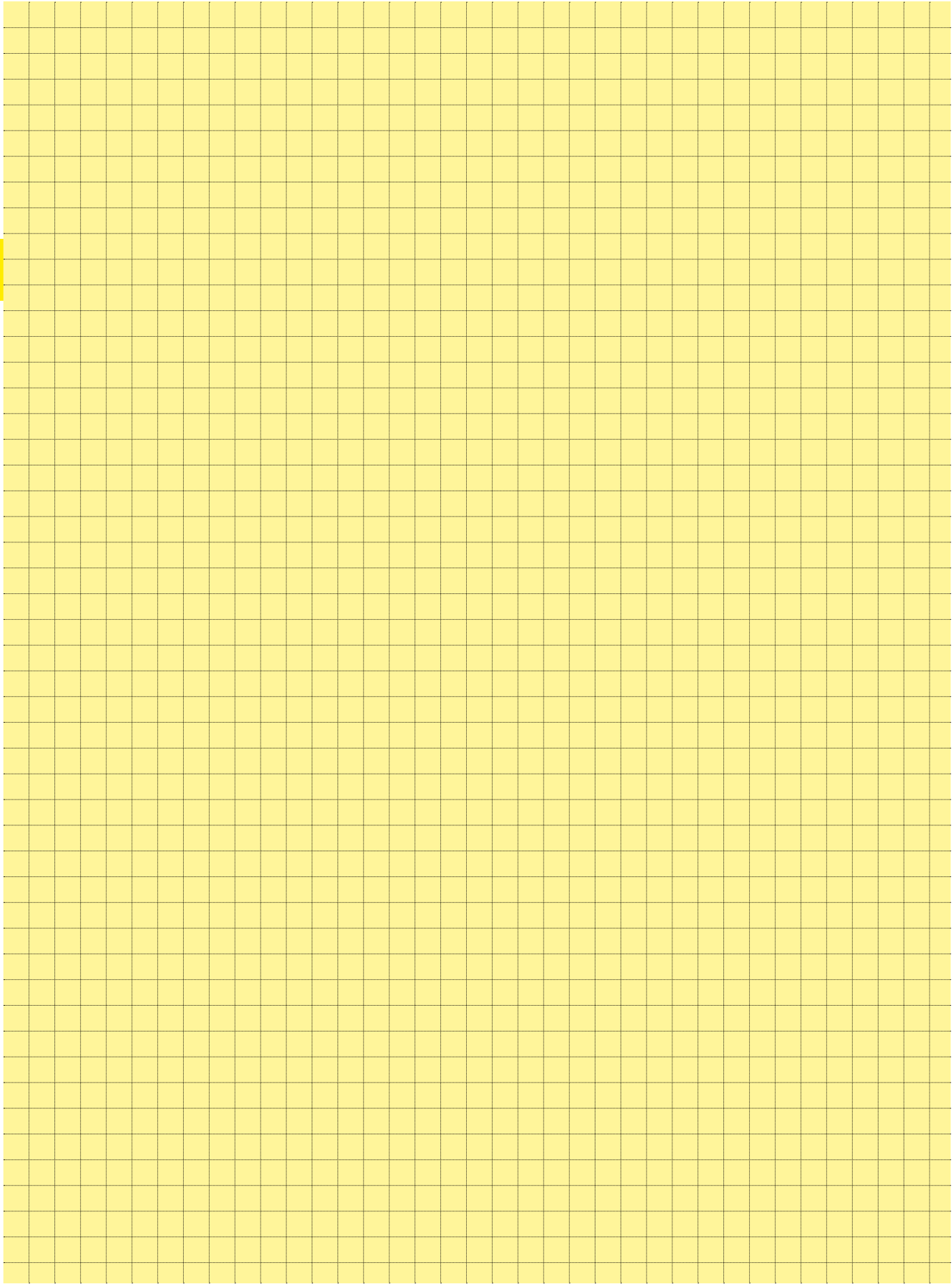



female 78





D-Sub – Mixed subminiature D connectors

Page

D-Sub mixed connector system – general information		04.02
Contact arrangements		04.03
Connectors for pcb applications – general information		04.04
Connectors for cable applications – general information		04.05
Technical characteristics for shells		04.06
Mixed shells with pre-mounted signal solder cup contacts		04.07
Shells without signal contacts for cable applications ..		04.14
Coded shells without signal contacts for cable applications.....		04.15
Mixed shells for signal crimp contacts		04.17
Technical characteristics for special contacts		04.21
Turned crimp contacts for cable applications		04.22
High voltage contacts for cable applications		04.23
Straight power contacts for cable applications		04.24
Coaxial contacts for cable applications		04.26
Pneumatic contacts for cable applications		04.29
Pcb hole patterns		04.30
Board drillings for connectors with straight pcb contacts		04.30
Board drillings for connectors with right angled pcb contacts		04.35
Customer request form for pcb connectors		04.40
Customer request form for cable connectors		04.42



HARTINGs' mixed D-Sub range brings the advantage of an industry standard I/O interconnect product with the possibility to customise for any application.

The range is designed around **the standard D-Sub shell sizes** with **the possibility to have a blend of contacts** such as signals with coaxial, power, high voltage or pneumatic contacts. Due to its construction, the product is **fully shielded** and helps reducing the EMI/RFI leakage.

All contacts are machined with two different platings.

When hot plug-in is required, **first mate last break** contacts can also be supplied.

For connectors to be fitted on a board with SMT components, they can be supplied in an **SMC (PiHIR) version** which is assembled in the reflow solder process, thus reducing assembly cost.

In addition, a complete range of accessories such as clinch nut, spacers, board locks, female screw lock, etc. are available. For **blind mating feature**, a specific high performance solution has been developed based on the combination of a floating plate and guiding pins providing up to 2.2 mm realignment capability. With all these accessories, the requirements of most applications are achievable and it makes this product range very attractive thanks to its versatility, reliability and cost effectiveness.

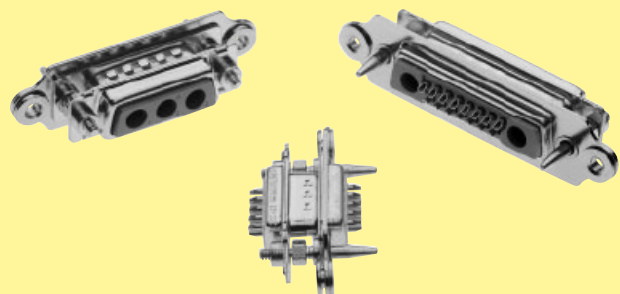

This blind mating concept is also achievable on the standard D as shown on the photo.

Contact arrangements

The table shows the standard range supported by HARTING. Two versions are special since they allow to mix in the same shell male and female contacts: 2W2C and 3W3C. The purpose of these versions is to have a 100 % mating proof feature (the insulator shape prevents a 180° reversed mating).

The structure of the connectors' identification is so that the left side digits give the total number of contacts and the right side digits the number of special contacts which can be either power, coaxial or high voltage style.

Example: 13W3 stands for 13 contacts in total with 10 signal contacts and 3 special contacts.

	Shell size	
2W2	1	
2W2C	1	
5W1	1	
3W3	2	
3W3C	2	
7W2	2	
11W1	2	
5W5	3	
9W4	3	
13W3	3	
17W2	3	
21W1	3	

	Shell size	
7W7	4	
8W8	4	
13W6	4	
21WA4	4	
25W3	4	
27W2	4	
24W7	5	
36W4	5	
43W2	5	

Note:
for any other layout please consult your HARTING representative.

Connectors for pcb applications – general information

The range of pcb connectors available at HARTING is summarised in the table under. For each of the basic connector versions, the available contact styles are documented with termination process, pitch, plating, rating for power contacts and impedance for coaxial contact etc..., as well as the accessory configuration.

Pcb connectors are delivered fully loaded thus providing a very good positioning of the contacts in their cavities for an easy and safe insertion of the pins in the pcb holes particularly crucial in the right angled versions.



Due to the numerous possibilities offered with the pcb connectors, suggested method is to contact your local HARTING representative to determine the part number to order; see customer request form on pages 04.40 and 04.41.

	Straight		Right angled	
Insulator body	<ul style="list-style-type: none"> • Standard • SMC: Solder Reflow Compatible 		<ul style="list-style-type: none"> • Standard • SMC: Solder Reflow Compatible 	
Signal contacts	Solder termination <ul style="list-style-type: none"> • Pitch: 2.84 mm • Plating: 0.76 µm Au over Ni • Pcb thickness from 1.6 to 3.2 mm 		Solder termination <ul style="list-style-type: none"> • Pitch: 2.54 mm • Plating: 0.76 µm Au over Ni • Pcb thickness from 1.6 to 3.2 mm 	
Power contacts	Solder termination <ul style="list-style-type: none"> • Rating: 20, 30, 40 A • Plating: 0.76 µm Au over Ni Press-in termination <ul style="list-style-type: none"> • Rating: 30 A • Plating: 0.76 µm Au over Ni 		Solder termination <ul style="list-style-type: none"> • Rating: 20, 30, 40 A • Plating: 0.76 µm Au over Ni 	
Coaxial contacts	Solder termination <ul style="list-style-type: none"> • 50 or 75 Ω • Plating: 1.3 µm Au over Ni inner conductor 0.76 µm Au over Ni outer ring 		Solder termination <ul style="list-style-type: none"> • 50 or 75 Ω • Plating: 1.3 µm Au over Ni inner conductor 0.76 µm Au over Ni outer ring 	
Accessories	Through hole		Metal bracket with board lock and through hole	
	Nut: M3 or UNC 4-40		Metal bracket with board lock and clinch nut M3 or UNC 4-40	
	Spacer: M3 or UNC 4-40		Metal bracket with board lock and female screw lock UNC 4-40	
	Spacer (M3 or UNC 4-40) with board lock			
	Spacer + board lock + female screw lock M3 or UNC 4-40			

D-Sub - M

Connectors for cable applications – general information

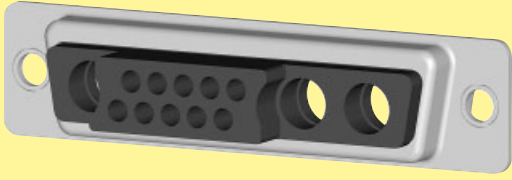
Two termination processes are available: crimp or solder

<p>Shell</p>		
<p>Signal contacts</p>	<p>Crimp termination</p> <ul style="list-style-type: none"> For wire gauge: AWG 20-24 or 26-28 Plating: 0.76 µm or 0.2 µm Au over Ni 	<p>Pre-mounted solder cup contacts</p> <ul style="list-style-type: none"> Plating: 0.76 µm or 0.1 µm Au over Ni
<p>Power contacts</p>	<p>Crimp</p> <ul style="list-style-type: none"> Rating: 10, 20, 30, 40 A Plating: <ul style="list-style-type: none"> Mating side 0.76 µm or 0.2 µm Au Terminating side 0.2 µm Au <p>Solder cup</p> <ul style="list-style-type: none"> Rating: 10, 20, 30, 40 A Plating: <ul style="list-style-type: none"> Mating side 0.76 µm or 0.2 µm Au Terminating side 0.2 µm Au or 5 µm Sn 	<p>Crimp</p> <ul style="list-style-type: none"> Rating: 10, 20, 30, 40 A Plating: <ul style="list-style-type: none"> Mating side 0.76 µm or 0.2 µm Au Terminating side 0.2 µm Au <p>Solder cup</p> <ul style="list-style-type: none"> Rating: 10, 20, 30, 40 A Plating: <ul style="list-style-type: none"> Mating side 0.76 µm or 0.2 µm Au Terminating side 0.2 µm Au or 5 µm Sn
<p>Coaxial contacts¹⁾</p>	<p>Solder/crimp termination resp. Crimp/crimp termination</p> <ul style="list-style-type: none"> 50 or 75 Ω Plating: <ul style="list-style-type: none"> Mating side <ul style="list-style-type: none"> 1.3 µm or 0.2 µm Au inner conductor 0.76 µm or 0.2 µm Au outer ring Terminating side <ul style="list-style-type: none"> 1.3 µm or 0.2 µm Au inner conductor 0.2 µm Au or 5 µm Sn outer ring Ferrule 0.2 µm Au or 5 µm Sn Cables: RG 178, 179 ... 	<p>Solder/crimp termination resp. Crimp/crimp termination</p> <ul style="list-style-type: none"> 50 or 75 Ω Plating: <ul style="list-style-type: none"> Mating side <ul style="list-style-type: none"> 1.3 µm or 0.2 µm Au inner conductor 0.76 µm or 0.2 µm Au outer ring Terminating side <ul style="list-style-type: none"> 1.3 µm or 0.2 µm Au inner conductor 0.2 µm Au or 5 µm Sn outer ring Ferrule 0.2 µm Au or 5 µm Sn Cables: RG 178, 179 ...
<p>High voltage contacts</p>	<p>Solder termination</p> <ul style="list-style-type: none"> Plating: 1.3 µm Au over Ni terminating and mating side 	<p>Solder termination</p> <ul style="list-style-type: none"> Plating: 1.3 µm Au over Ni terminating and mating side

¹⁾ Coaxial contacts are provided in two versions:

- Inner conductor soldered and outer part crimped (solder/crimp termination)
- Both inner and outer part crimped (crimp/crimp termination); this version is recommended for medium or large size volume since crimping is faster than soldering.

Number of contacts 2, 3, 5, 7, 8, 9, 11, 13, 17, 21, 24, 25, 27, 36, 43

Approvals DIN 41 652, part 1

Working current 5 A for signal contacts

Temperature range -55 °C ... + 125 °C
 The higher temperature limit includes the ambient and heating effect of the contacts under load

Materials
 Mouldings Thermoplastic resin, glass-fibre filled (Polyester)
 UL 94-V0
 color: green for standard
 black for crimp

Metal shell Plated steel

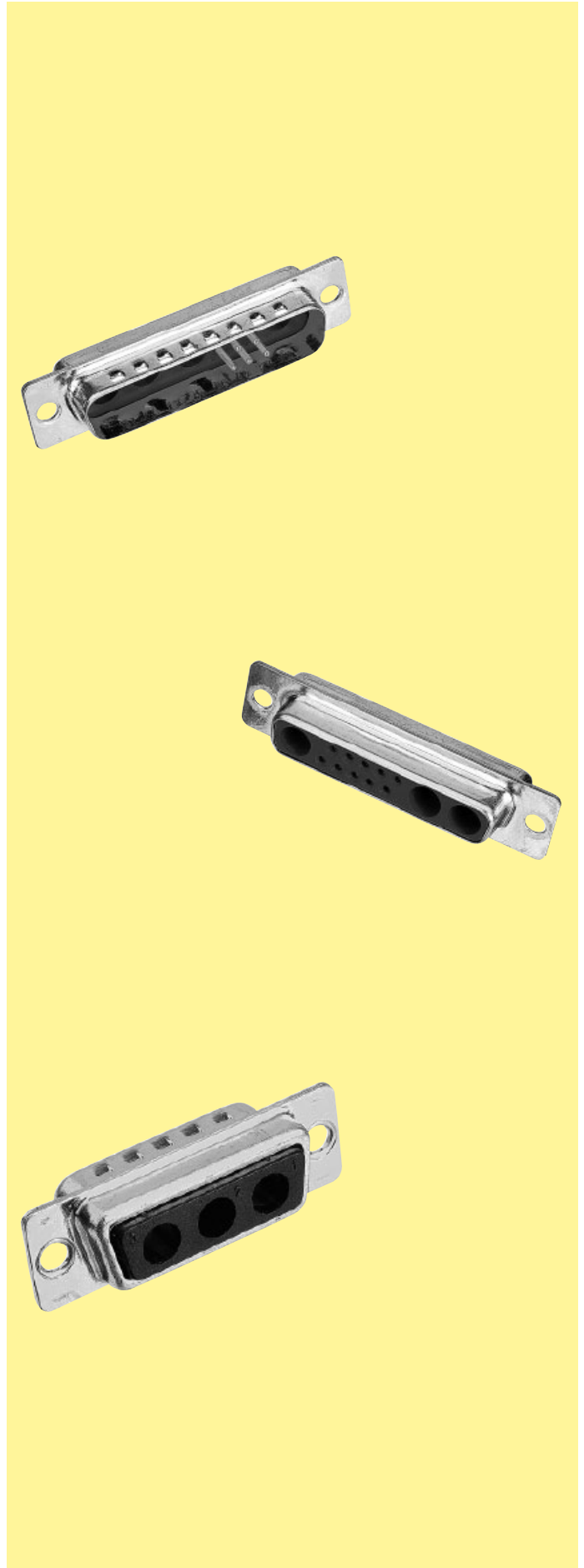

D-Sub - M

Number of contacts

7-27



Mixed shells with pre-mounted signal solder cup contacts

Identification	No. of contacts ¹⁾	Part No.			
		male connectors		female connectors	
		Performance level 3	S4 ²⁾	Performance level 3	S4 ²⁾
	7W2	09 69 211 7072	09 69 211 5072	09 69 201 7072	09 69 201 5072
	17W2	09 69 311 7172	09 69 311 5172	09 69 301 7172	09 69 301 5172
	21WA4	09 69 411 7214	09 69 411 5214	09 69 401 7214	09 69 401 5214
	27W2	09 69 411 7272	09 69 411 5272	09 69 401 7272	09 69 401 5272

Male connectors

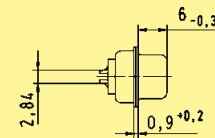
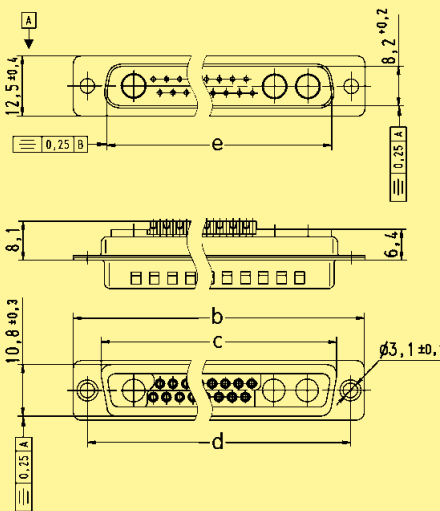

Solder cup termination for AWG 20 (0.5 mm²)

	a	b	c	d	e
7W2	24.6	39.1	27.5	33.30	25.2
17W2	38.3	53.0	41.3	47.04	38.9
21WA4	54.8	69.3	57.7	63.50	55.3
27W2	54.9	69.3	57.7	63.50	55.3

Female connectors

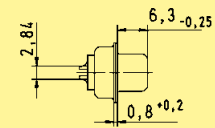
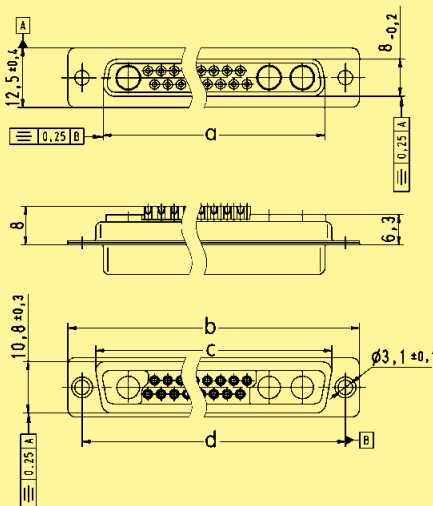

Solder cup termination for AWG 20 (0.5 mm²)

Dimensions in mm

¹⁾ Explanations see page 04.03

²⁾ S4 = 0.76 µm Au or PdNi equivalent

Board drillings see pages 04.30 ff

Order special contacts separately. See pages 04.21 ff

D-Sub - M

Number of contacts

9-25

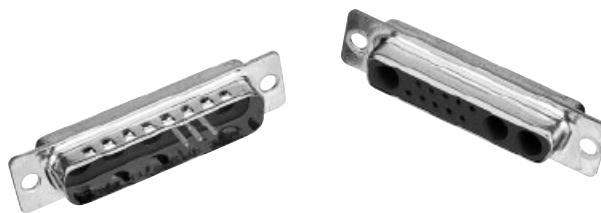

Mixed shells with pre-mounted signal solder cup contacts

Identification	No. of contacts ¹⁾	Part No.			
		male connectors		female connectors	
		Performance level 3	S4 ²⁾	Performance level 3	S4 ²⁾
	9W4	09 69 311 7094	09 69 311 5094	09 69 301 7094	09 69 301 5094
	13W3	09 69 311 7133	09 69 311 5133	09 69 301 7133	09 69 301 5133
	25W3	09 69 411 7253	09 69 411 5253	09 69 401 7253	09 69 401 5253

Male connectors

9W4

Solder cup termination for AWG 20 (0.5 mm²)

13W3, 25W3

Solder cup termination for AWG 20 (0.5 mm²)

	b	c	d	e
13W3	53.0	41.3	47.04	38.90
25W3	69.3	57.7	63.50	49.84

Dimensions in mm

D-Sub - M

¹⁾ Explanations see page 04.03
²⁾ S4 = 0.76 µm Au or PdNi equivalent
 Board drillings see pages 04.30 ff

Drawings for female connectors see page 04.09
 Order special contacts separately. See pages 04.21 ff

Number of contacts

9-25

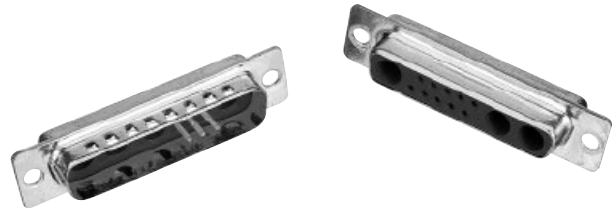

Mixed shells with pre-mounted signal solder cup contacts

Identification

Drawing

Dimensions in mm

Female connectors

9W4

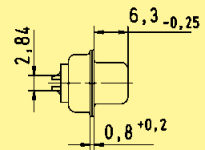
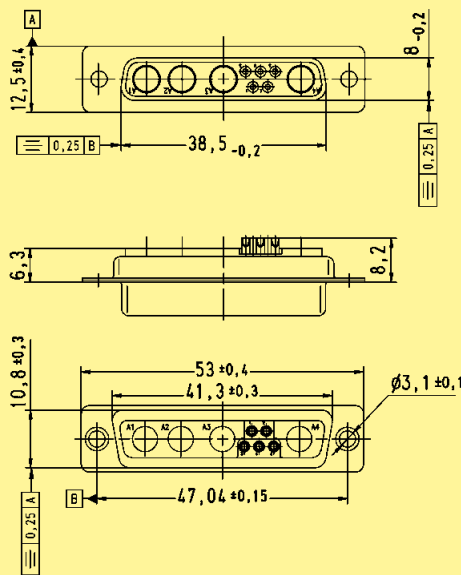

Solder cup termination for AWG 20 (0.5 mm²)

13W3, 25W3

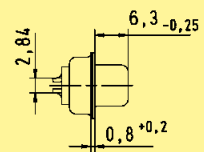
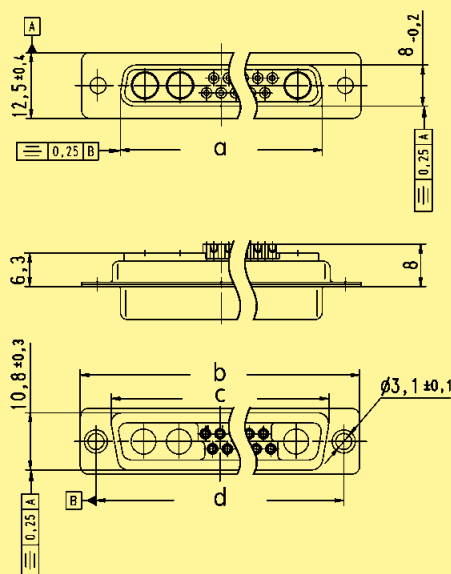

Solder cup termination for AWG 20 (0.5 mm²)

	a	b	c	d
13W3	38.3	53.0	41.3	47.04
25W3	54.9	69.3	57.7	63.50

Number of contacts

5-21



Mixed shells with pre-mounted signal solder cup contacts

Identification	No. of contacts ¹⁾	Part No.			
		male connectors		female connectors	
		Performance level 3	S4 ²⁾	Performance level 3	S4 ²⁾
	5W1	09 69 111 7051	09 69 111 5051	09 69 101 7051	09 69 101 5051
	11W1	09 69 211 7111	09 69 211 5111	09 69 201 7111	09 69 201 5111
	21W1	09 69 311 7211	09 69 311 5211	09 69 301 7211	09 69 301 5211

Male connectors

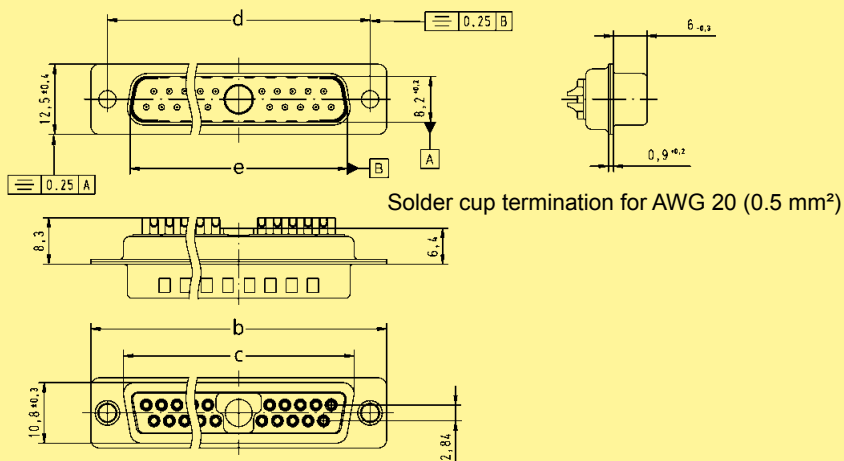

Female connectors

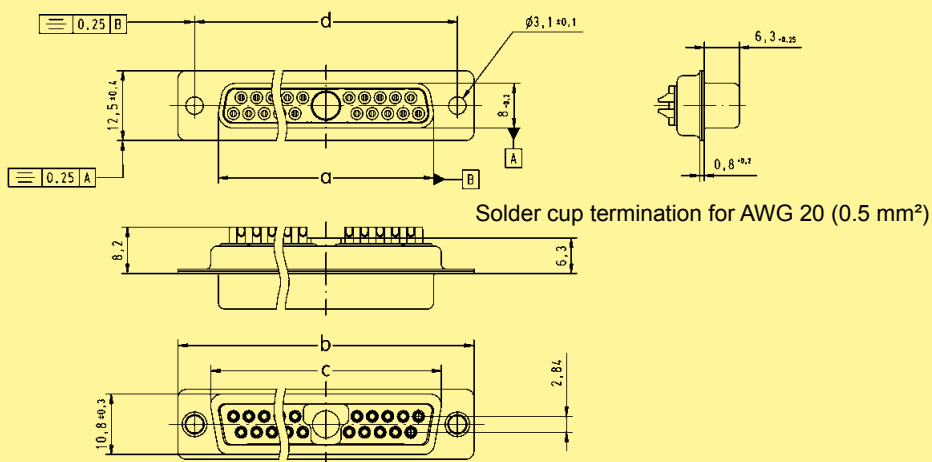

	a	b	c	d	e
5W1	16.4	30.8	19.3	25.00	16.9
11W1	24.7	39.1	27.5	33.30	25.2
21W1	38.5	53.0	41.3	47.04	38.9

Dimensions in mm

D-Sub - M

¹⁾ Explanations see page 04.03
²⁾ S4 = 0.76 µm Au or PdNi equivalent
 Board drillings see pages 04.30 ff

Order special contacts separately. See pages 04.21 ff

Number of contacts

13



Mixed shells with pre-mounted signal solder cup contacts

Identification	No. of contacts ¹⁾	Part No.			
		male connectors		female connectors	
		Performance level 3	S4 ²⁾	Performance level 3	S4 ²⁾
	13W6	09 69 411 7136	09 69 411 5136	09 69 401 7136	09 69 401 5136

Male connectors

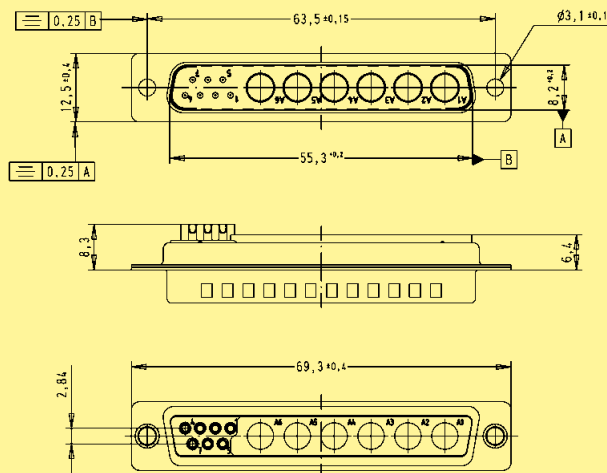

Solder cup termination for AWG 20 (0.5 mm²)

Female connectors

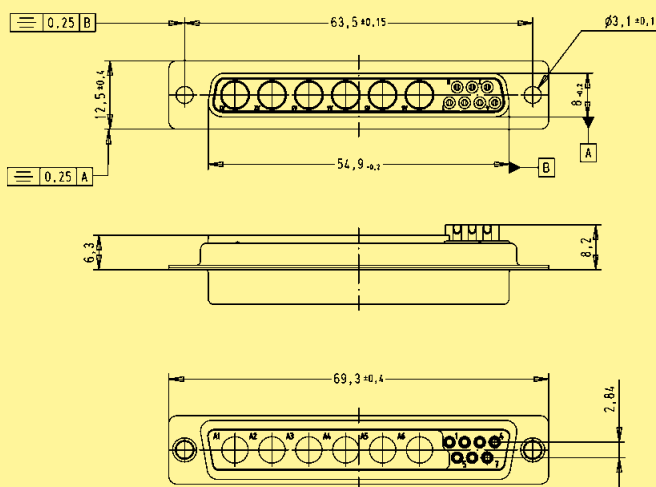

Solder cup termination for AWG 20 (0.5 mm²)

Dimensions in mm

¹⁾ Explanations see page 04.03
²⁾ S4 = 0.76 µm Au or PdNi equivalent
 Board drillings see pages 04.30 ff

Order special contacts separately. See pages 04.21 ff

D-Sub - M

Number of contacts

24

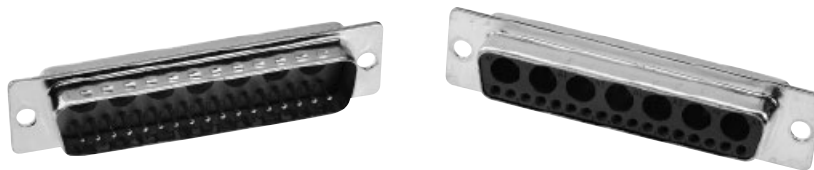

Mixed shells with pre-mounted signal solder cup contacts

Identification	No. of contacts ¹⁾	Part No.			
		male connectors		female connectors	
		Performance level 3	S4 ²⁾	Performance level 3	S4 ²⁾
24W7		09 69 511 7247	09 69 511 5247	09 69 501 7247	09 69 501 5247

D-Sub - M

Male connectors

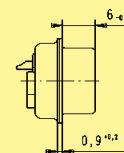
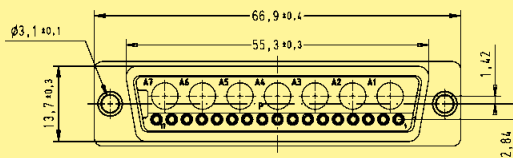
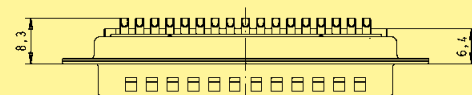
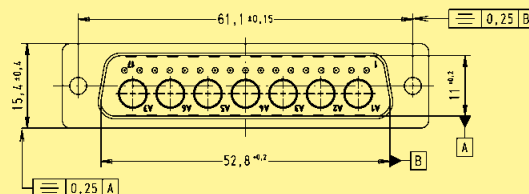

Solder cup termination for AWG 20 (0.5 mm²)

Female connectors

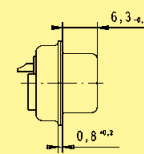
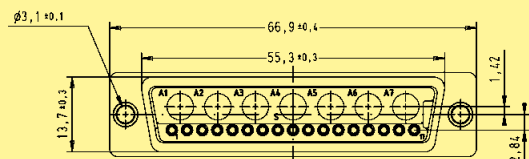
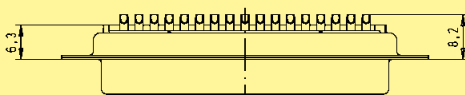
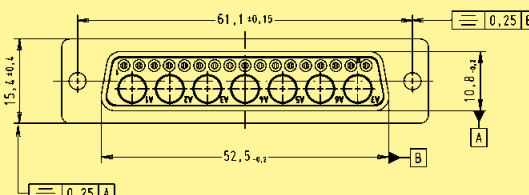

Solder cup termination for AWG 20 (0.5 mm²)

Dimensions in mm

¹⁾ Explanations see page 04.03
²⁾ S4 = 0.76 µm Au or PdNi equivalent
 Board drillings see pages 04.30 ff

Order special contacts separately. See pages 04.21 ff

Number of contacts

36-43

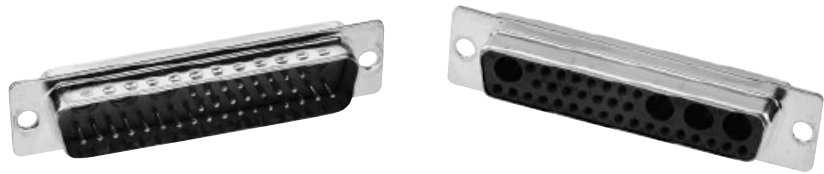

Mixed shells with pre-mounted signal solder cup contacts

Identification	No. of contacts ¹⁾	Part No.			
		male connectors		female connectors	
		Performance level 3	S4 ²⁾	Performance level 3	S4 ²⁾
	36W4	09 69 511 7364	09 69 511 5364	09 69 501 7364	09 69 501 5364
	43W2	09 69 511 7432	09 69 511 5432	09 69 501 7432	09 69 501 5432

Male connectors

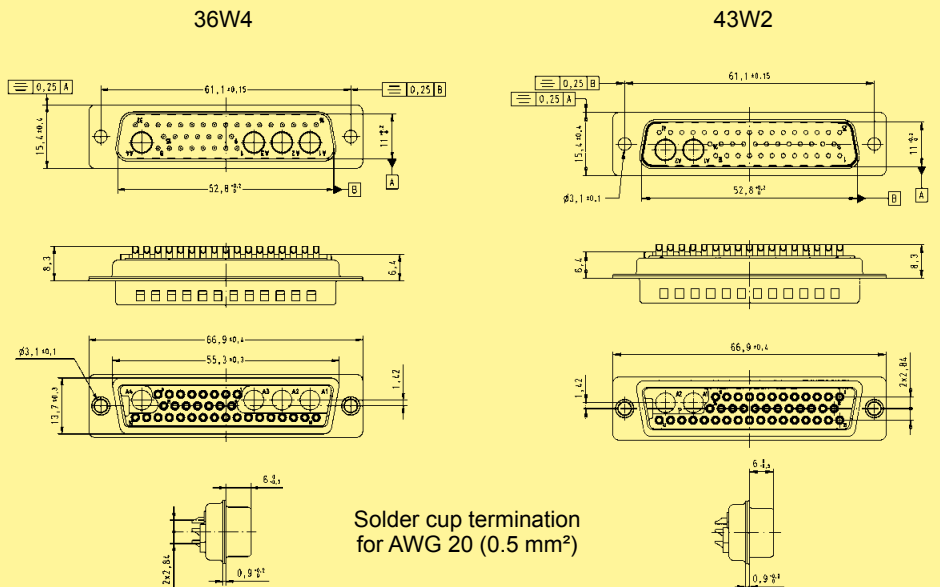

Female connectors

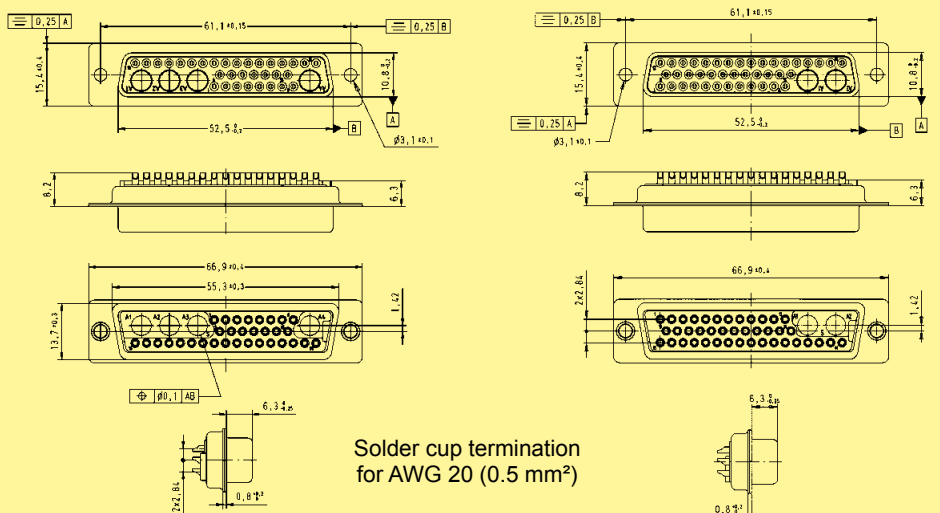

Dimensions in mm

¹⁾ Explanations see page 04.03
²⁾ S4 = 0.76 µm Au or PdNi equivalent
 Board drillings see pages 04.30 ff

Order special contacts separately. See pages 04.21 ff

D-Sub - M

Number of contacts

2-8



Shells without signal contacts for cable applications

Identification	No. of contacts ¹⁾	Part No.	
		male connectors	female connectors
	2W2	09 69 110 0522	09 69 100 0522
	3W3	09 69 210 0033	09 69 200 0033
	5W5	09 69 310 0055	09 69 300 0055
	7W7	09 69 410 0077	09 69 400 0077
	8W8	09 69 410 0088	09 69 400 0088

D-Sub - M

Male connectors

	a	b	c	d	e	f	g
2W2	16.9	30.8	-	25.00	16.4	8.7	8.6
3W3	25.2	39.1	27.5	33.30	24.6	6.4	6.3
5W5	38.9	53.0	41.3	47.04	38.3	6.4	6.3
7W7	55.3	69.3	57.7	63.50	54.9	6.4	6.3
8W8	55.3	69.3	57.7	63.50	54.8	6.4	6.3

Female connectors

¹⁾ Explanations see page 04.03
 Board drillings see pages 04.30 ff
 Order special contacts separately. See pages 04.21 ff

Number of contacts

2



Coded shells without signal contacts for cable applications

Identification	No. of contacts ¹⁾	Part No.
		male connector
	2W2C	09 69 110 0022
		female connector
		09 69 100 0022

D-Sub - M

Male connectors

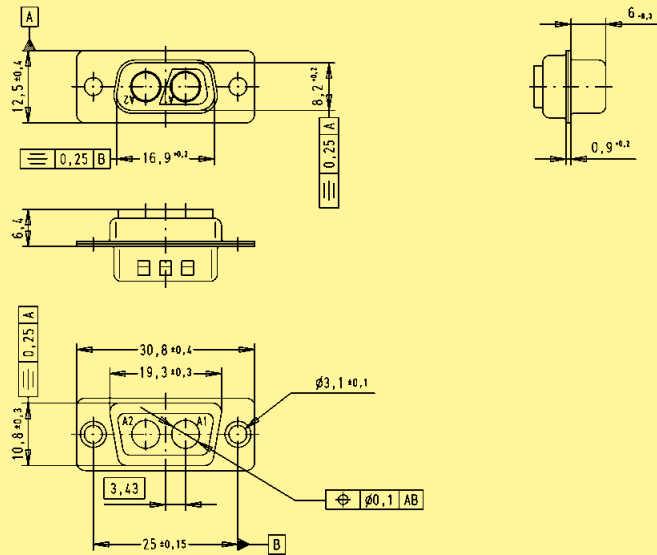

Female connectors

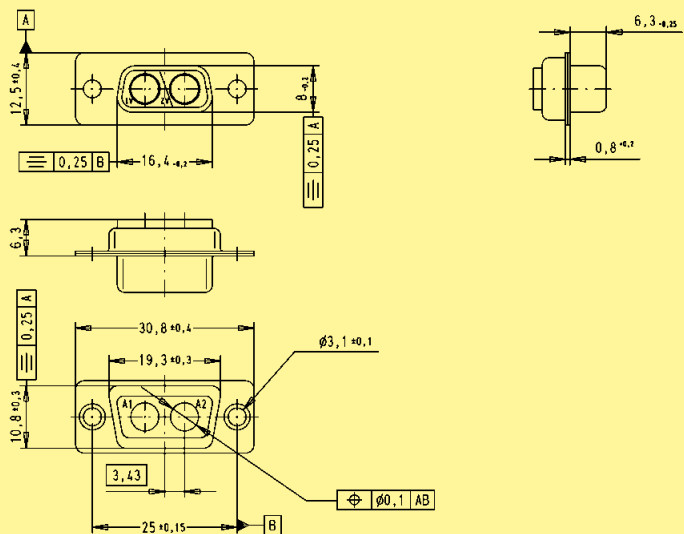

Dimensions in mm

¹⁾ Explanations see page 04.03
 Board drillings see pages 04.30 ff
 Order special contacts separately. See pages 04.21 ff

Number of contacts

3



Coded shells without signal contacts for cable applications

Identification	No. of contacts ¹⁾	Part No.	
		male connector	female connector
	3W3C	09 69 210 0633	09 69 200 0633

D-Sub - M

Male connectors

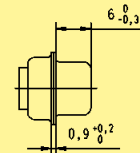
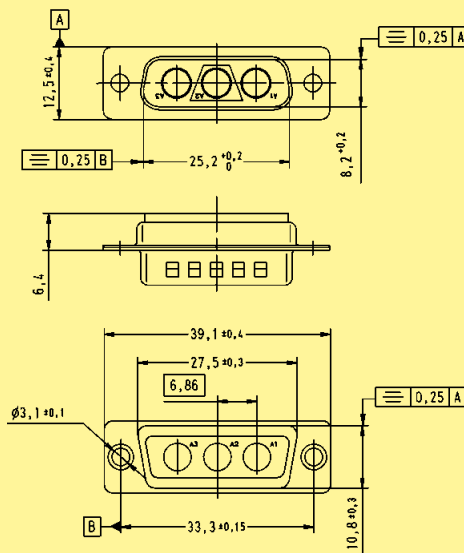

detail:
polarization feature

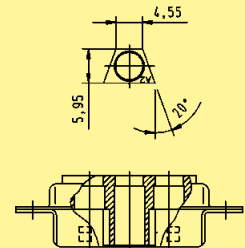

Female connectors

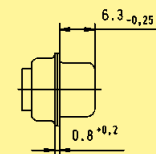
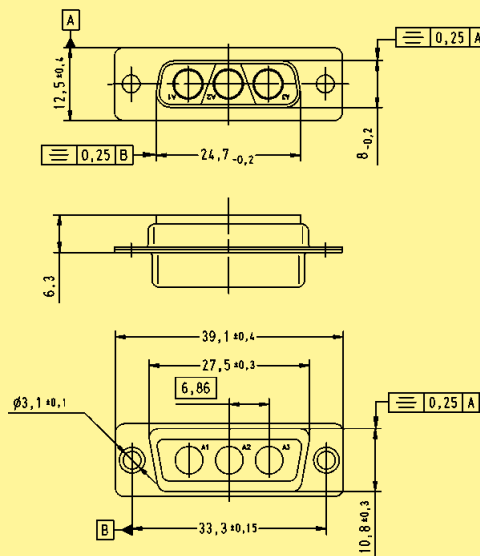

detail:
polarization feature

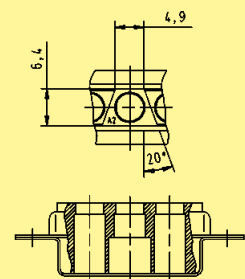

Dimensions in mm

¹⁾ Explanations see page 04.03
Board drillings see pages 04.30 ff
Order special contacts separately. See pages 04.21 ff

Number of contacts

7-27



Mixed shells for signal crimp contacts

Identification	No. of contacts ¹⁾	Part No.	
		male connectors	female connectors
	7W2	09 69 212 0072	09 69 202 0072
	17W2	09 69 312 0172	09 69 302 0172
	21WA4	09 69 412 0214	09 69 402 0214
	27W2	09 69 412 0272	09 69 402 0272

Male connectors

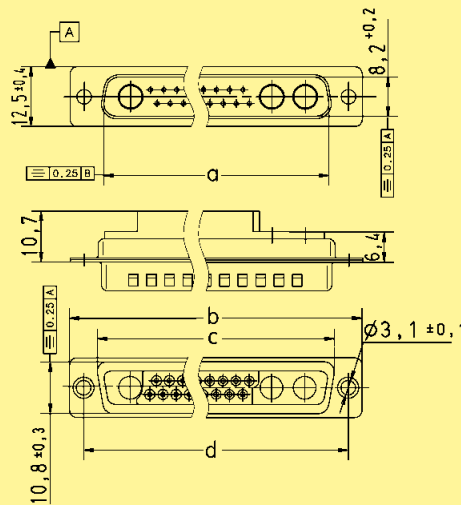

	a	b	c	d	e
7W2	25.2	39.1	27.5	33.30	24.7
17W2	38.9	53.0	41.3	47.04	38.5
21WA4	55.3	69.3	57.7	63.50	54.9
27W2	56.3	69.3	-	63.50	54.9

Female connectors

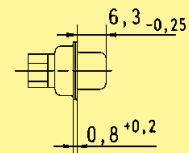
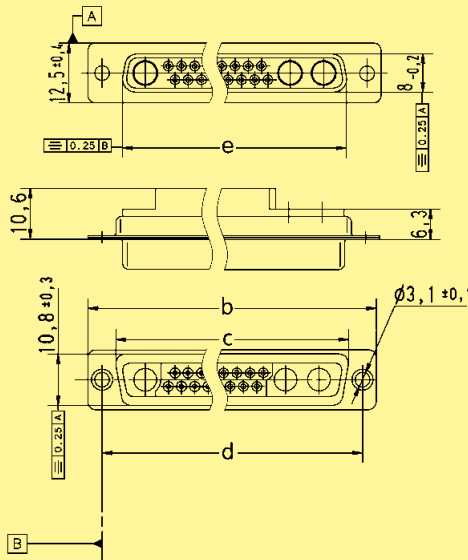

Dimensions in mm

¹⁾ Explanations see page 04.03
 Board drillings see pages 04.30 ff
 Order special contacts separately. See pages 04.21 ff

Number of contacts

13-25

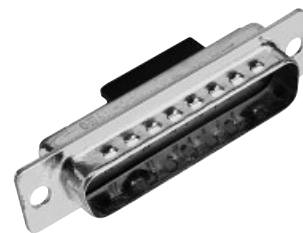

Mixed shells for signal crimp contacts

Identification	No. of contacts ¹⁾	Part No.	
		male connectors	female connectors
	13W3	09 69 312 0133	09 69 302 0133
	25W3	09 69 412 0253	09 69 402 0253

Male connectors

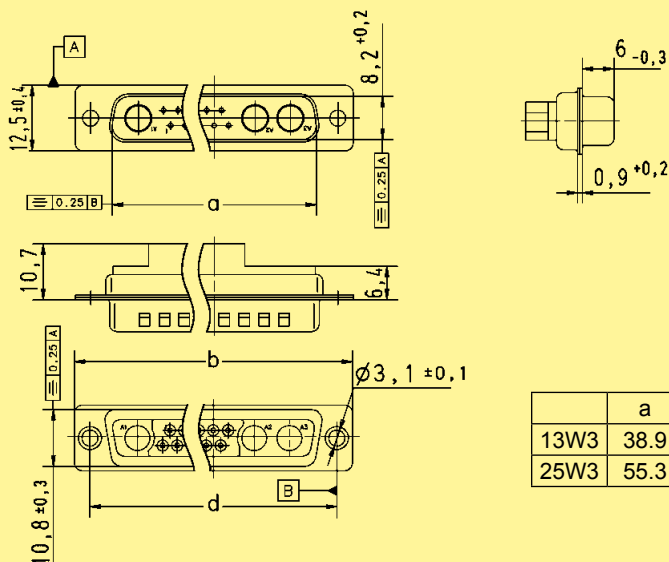

Female connectors

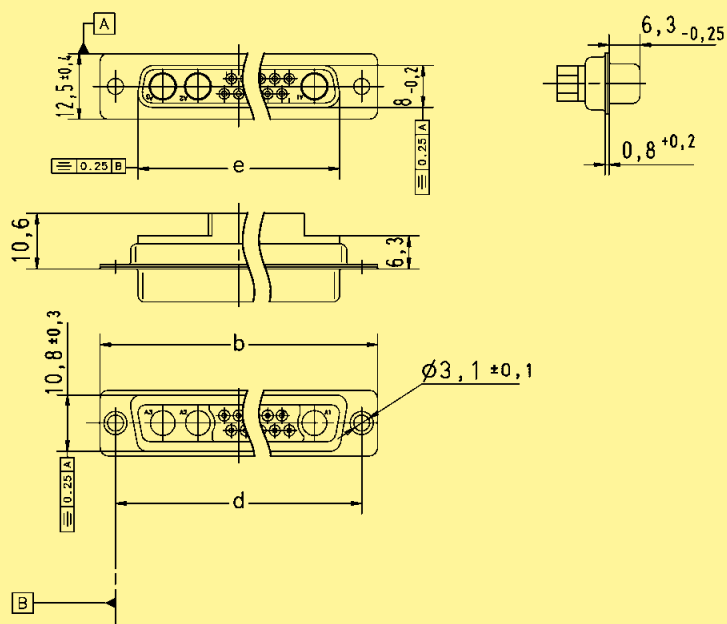

Dimensions in mm

¹⁾ Explanations see page 04.03
 Board drillings see pages 04.30 ff
 Order special contacts separately. See pages 04.21 ff

Number of contacts

11-21

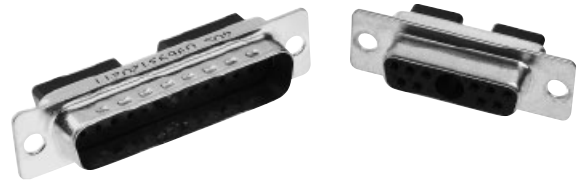

Mixed shells for signal crimp contacts

Identification	No. of contacts ¹⁾	Part No.	
		male connectors	female connectors
	11W1	09 69 212 0111	09 69 202 0111
	21W1	09 69 312 0211	09 69 302 0211

Male connectors

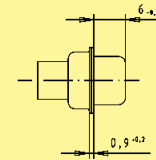
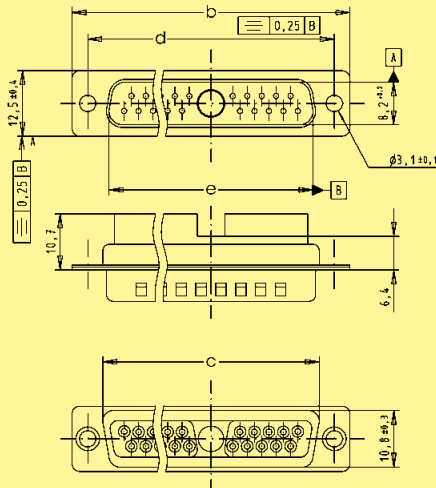

	a	b	c	d	e
11W1	24.7	39.1	27.5	33.30	25.2
21W1	38.5	53.0	41.3	47.04	38.9

Female connectors

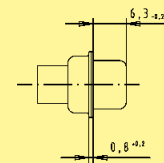
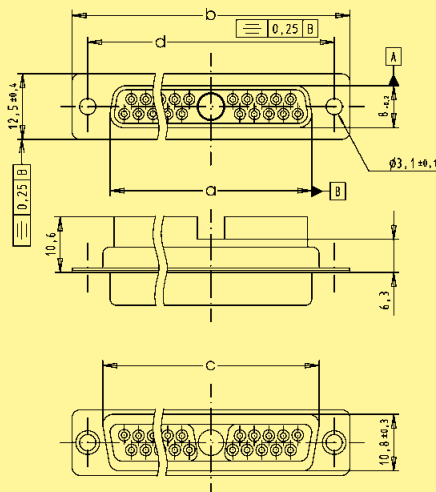

Dimensions in mm

¹⁾ Explanations see page 04.03
 Order special contacts separately. See pages 04.21 ff
 Board drillings see pages 04.30 ff

Number of contacts

36

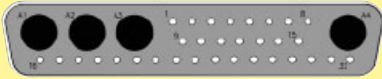

Mixed shells for signal crimp contacts

Identification	No. of contacts ¹⁾	Part No.	
		male connector	female connector
	36W4	09 69 512 0364	09 69 502 0364

Male connectors

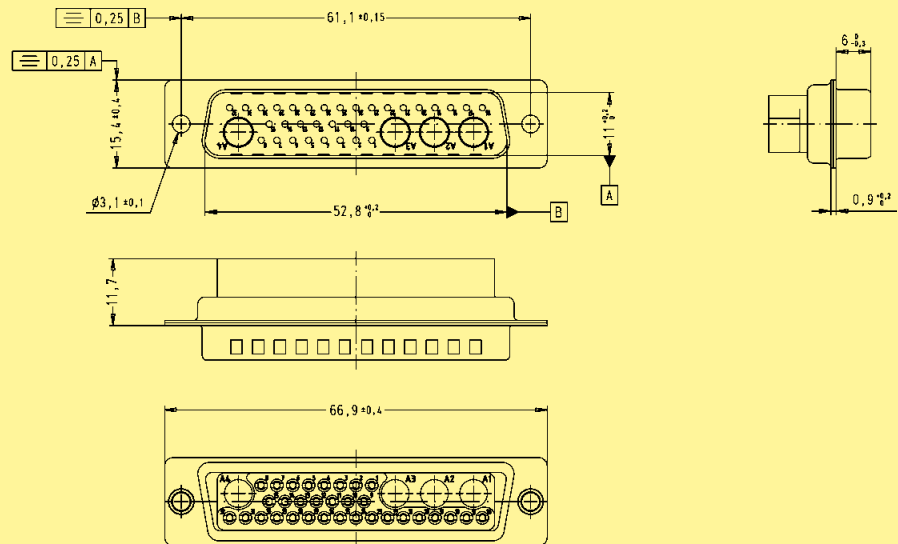

Female connectors

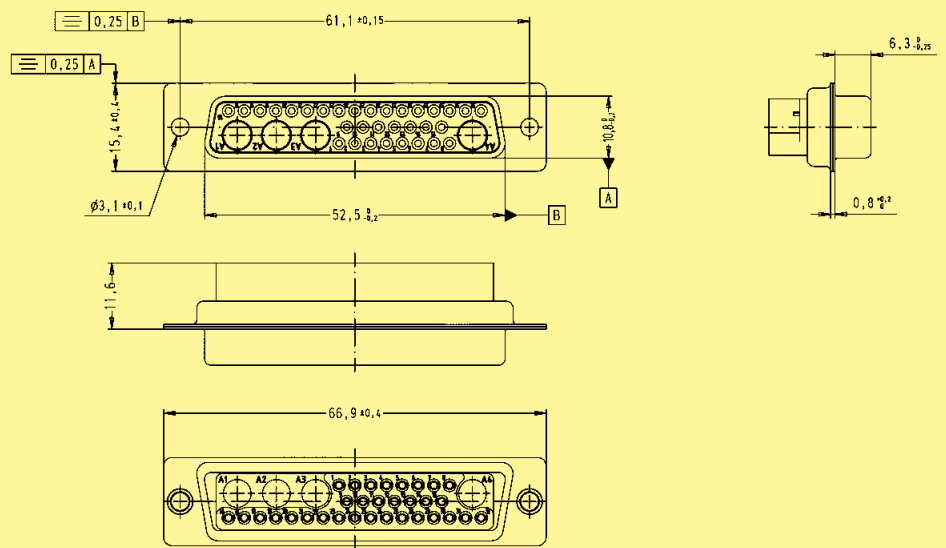

Dimensions in mm

¹⁾ Explanations see page 04.03
 Board drillings see pages 04.30 ff
 Order special contacts separately. See pages 04.21 ff

	Signal contacts see page 04.22	Coaxial contacts see pages 04.26 – 04.28	Power contacts see pages 04.24 + 04.25	High voltage contacts see page 04.23	Pneumatic contacts see page 04.29
Working current	5 A	2 A	10 A, 20 A, 30 A or 40 A	6 A DC	–
Test voltage $U_{r.m.s.}$	–	750 V / 50 Hz	–	4 kV / 50 Hz	–
Operating voltage	–	–	–	≤ 3 kV	–
Contact resistance	–	≤ 10 mΩ (inner and outer conductor)	≤ 1 mΩ	≤ 3 mΩ (outer conductor)	–
Impedance	–	50 / 75 Ω	–	–	–
Frequency range	–	0 - 2 GHz	–	–	–
Temperature range	–	-55 °C ... + 135 °C	-55 °C ... + 155 °C	-55 °C ... + 125 °C	-10 °C ... + 60 °C
Mating cycles					
high performance level	≥ 500	≥ 500	≥ 500	–	–
standard performance level	–	≥ 200	≥ 200	≥ 500	–
Mating force	≤ 3.4 N	≤ 7 N/mated pair	≤ 7 N/mated pair	≤ 5 N	–
Unmating force	≥ 0.2 N	≤ 7 N/mated pair	appr. 5 N	appr. 2.5 N	–
Max. pressure	–	–	–	–	7 bars at 20 °C
Materials					
Contacts	Copper alloy	Copper alloy	Copper alloy	Copper alloy	German silver
Plating for PCB applications*					
Mating side / terminating side	0.76 μm Au / 0.76 μm Au		0.76 μm Au / 5 μm Sn or 0.2 μm Au / 5 μm Sn	1.3 μm Au / 1.3 μm Au	–
Inner conductor mating side / terminating side	–	1.3 μm Au / 1.3 μm Au or 0.2 μm Au / 0.2 μm Au	–	–	–
Outer conductor mating side / terminating side	–	0.76 μm Au / 0.2 μm Au or 0.2 μm Au / 5 μm Sn	–	–	–
Retaining clip	–	Copper alloy	Copper alloy	PI	–
Insulator	–	PBFE/PBTP/PI	–	PTFE	–
O-ring	–	–	–	–	Vitton

Technical characteristics for shells see page 04.06

* **High performance** or standard performance level



Turned crimp contacts

Identification	Wire gauge (mm ²)	Part No.		
		Male contacts	Female contacts	High-end female contacts
		Performance level 1*	Performance level 1*	Performance level 1*
Individual contacts ¹⁾	AWG 22-18 0.33-0.82	09 67 000 3576	09 67 000 3476	09 67 000 3676
	AWG 24-20 0.25-0.52	09 67 000 8576	09 67 000 8476	09 67 000 8676
	AWG 26-22 0.13-0.33	09 67 000 5576	09 67 000 5476	09 67 000 5676
	AWG 28-24 0.09-0.25	09 67 000 7576	09 67 000 7476	09 67 000 7676

¹⁾ Minimum order 100 pieces or multiples of 100

Male contacts

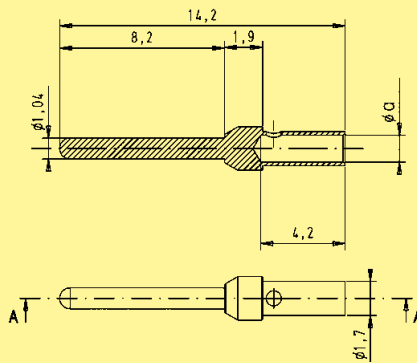

	a	groove
AWG 22-18	1.34	none
AWG 24-20	1.13	1
AWG 26-22	0.88	2
AWG 28-24	0.64	3

Female contacts

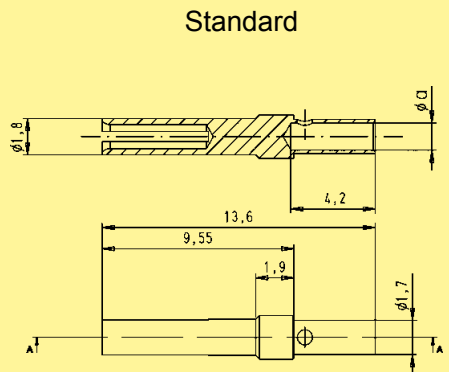

Standard

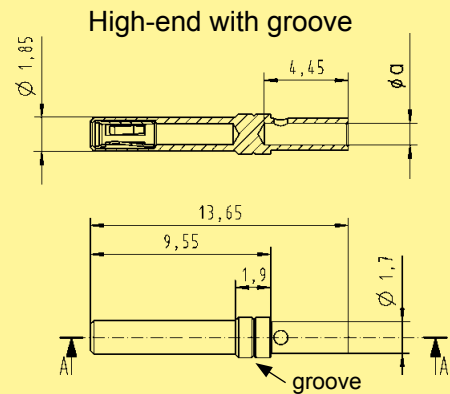

High-end with groove

* Performance level 1 as per CECC 75 301-802, 500 mating cycles, 10 days 4 mixed gas test – IEC 60 512
Use crimp tool with the part no. 09 99 000 0501 and the locator with the part no. 09 99 000 0531. Details see chapter 31

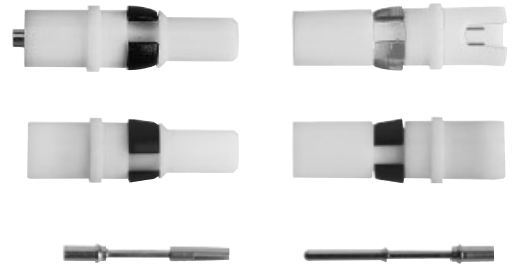

High voltage contacts for cable applications

Identification	Wire gauge (mm ²)	Part No.		
Straight versions		Male contacts Plating: 1.3 µm Au ¹⁾	Female contacts Plating: 1.3 µm Au ¹⁾	
	with solder termination	AWG 24 - 20 0.25 - 0.56	09 69 281 2550	09 69 181 2550
	with crimp termination ²⁾	AWG 30 - 24 0.05 - 0.25	09 69 282 2550	09 69 182 2550
Right angled versions				
with solder termination	AWG 24 - 20 0.25 - 0.56	09 69 681 2550	09 69 581 2550	

D-Sub - M

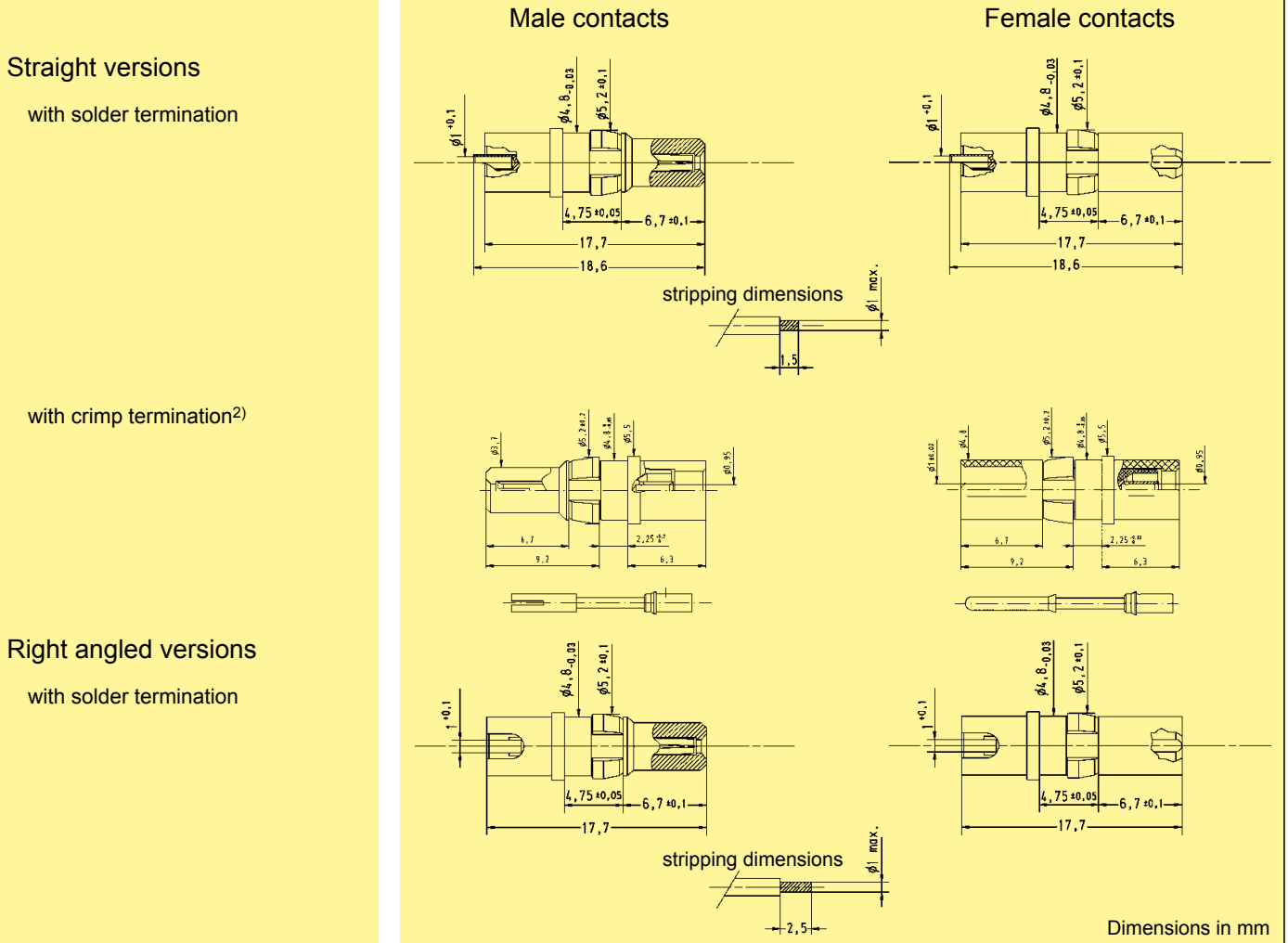

¹⁾ for mating and terminating side
²⁾ Tooling see chapter 31



Straight power contacts for cable applications

Identification	Rating (A)	Part No.	
Performance levels ▶		Performance level 3	S4¹⁾
Solder version			
Male contacts	10 20 30 40	09 69 281 7420 09 69 281 7421 09 69 281 7422 09 69 281 7423	09 69 281 5420 09 69 281 5421 09 69 281 5422 09 69 281 5423
Short male contacts	20 40	09 69 281 7821 09 69 281 7823	09 69 281 5821 09 69 281 5823
Female contacts	10 20 30 40	09 69 181 7420 09 69 181 7421 09 69 181 7422 09 69 181 7423	09 69 181 5420 09 69 181 5421 09 69 181 5422 09 69 181 5423
Short female contacts	20 40	09 69 181 7821 09 69 181 7823	09 69 181 5821 09 69 181 5823
Crimp version²⁾			
Male contacts	10 20 30 40	09 69 282 7420 09 69 282 7421 09 69 282 7422 09 69 282 7423	09 69 282 5420 09 69 282 5421 09 69 282 5422 09 69 282 5423
Short male contacts	20 40	09 69 282 7821 09 69 282 7823	09 69 282 5821 09 69 282 5823
Female contacts	10 20 30 40	09 69 182 7420 09 69 182 7421 09 69 182 7422 09 69 182 7423	09 69 182 5420 09 69 182 5421 09 69 182 5422 09 69 182 5423
Short female contacts	20 40	09 69 182 7821 09 69 182 7823	09 69 182 5821 09 69 182 5823

D-Sub - M

¹⁾ S4 = 0.76 µm Au or PdNi equivalent
²⁾ Tooling see chapter 31



Straight power contacts for cable applications

Identification

Drawing

Dimensions in mm

Male contacts

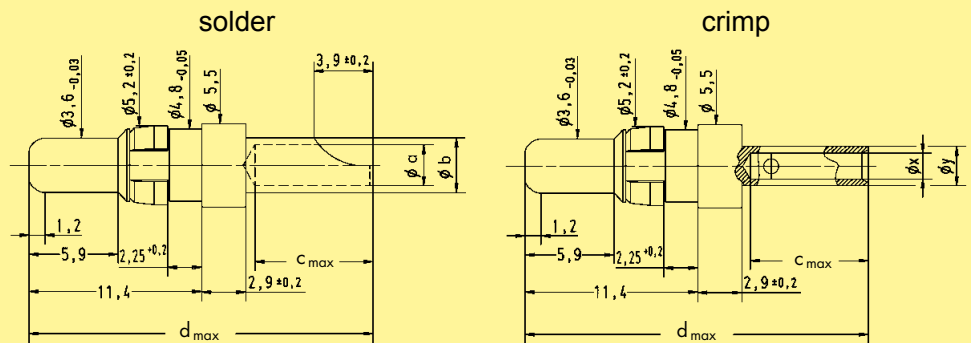

	Rating (A)	$\phi a -0.1$	$\phi b \pm 0.05$	C_{max}	d_{max}	e	$\phi x -0.1$	$\phi y \pm 0.05$	AWG
	10	1.8	2.54	7.8	23	7.5	1.7	2.6	16 - 20
	20	2.7	3.63	7.8	23	7.5	2.6	3.6	12 - 14
short version	20	2.7	3.63	4.7	19.2	4.5	2.6	3.6	12 - 14
	30	3.5	4.40	7.8	23	7.5	3.7	4.7	10 - 12
	40	4.8	5.50	7.8	23	7.5	4.6	5.8	8 - 10
short version	40	4.8	5.50	6.4	20	6.1	4.6	5.8	8 - 10

	Rating (A)	min./max. conductor ϕ	min./max. conductor cross section [mm ²]
	10	0.9 to 1.7	0.64 to 2.27
	20	1.8 to 2.6	2.54 to 5.31
short version	20	1.8 to 2.6	2.54 to 5.31
	30	2.2 to 3.7	3.80 to 10.75
	40	2.9 to 4.6	6.61 to 16.62
short version	40	2.9 to 4.6	6.61 to 16.62

Female contacts

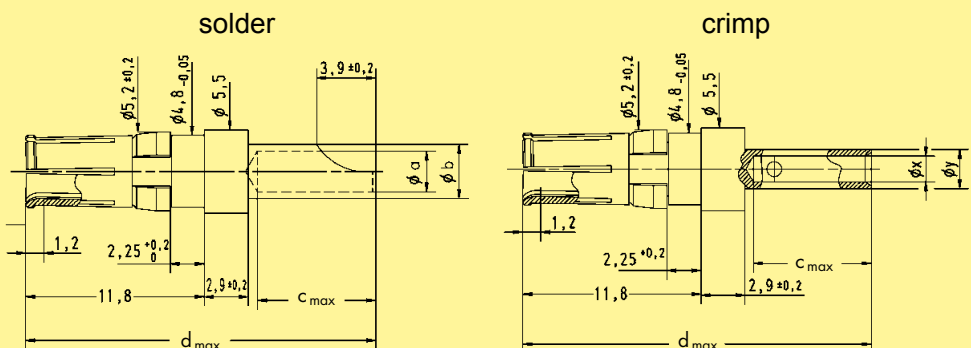

stripping dimensions for male and female contacts

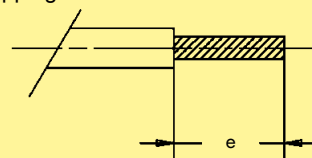

D-Sub - M



Coaxial contacts for cable applications

Identification	Impedance (Ω)	Part No.			
		Straight male contacts		Straight female contacts	
		Performance level 3	S4 ¹⁾	Performance level 3	S4 ¹⁾
Solder / crimp contact					
for cables RG 174 U, 188 AU, 316 U	50	09 69 281 7140	09 69 281 5140	09 69 181 7140	09 69 181 5140
for cables RG 178 BU, 196 AU, 404 U	50	09 69 281 7141	09 69 281 5141	09 69 181 7141	09 69 181 5141
for cables RG 58 CU, 141 AU	50	09 69 281 7143	09 69 281 5143	09 69 181 7143	09 69 181 5143
for cables RG 179 BU, 187 AU	75	09 69 281 7230	09 69 281 5230	09 69 181 7230	09 69 181 5230
for cables RGD 179	75	09 69 281 7233	09 69 281 5233	09 69 181 7233	09 69 181 5233
Crimp / crimp contact					
for cables RG 174 U, 188 AU, 316 U	50	09 69 282 7140	09 69 282 5140	09 69 182 7140	09 69 182 5140
for cables RG 179 BU, 187 AU	75	09 69 282 7230	09 69 282 5230	09 69 182 7230	09 69 182 5230
for cables RG 59	75	09 69 282 7232	09 69 282 5232	09 69 182 7232	09 69 182 5232
for cables RGD 179	75	09 69 282 7233	09 69 282 5233	09 69 182 7233	09 69 182 5233

Harnessing dimensions (mm)

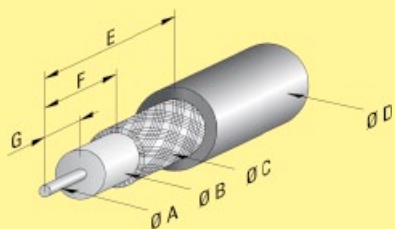

Part No.	Ø A	Ø B	Ø C	Ø D	E	F	G
09 69 181 x140 09 69 281 x140	0.85	1.9	2.3	3.2	9.5	5.0	3.0
09 69 181 x141 09 69 281 x141	0.85	1.2	1.4	2.3	9.5	5.0	3.0
09 69 181 x143 09 69 281 x143	1.00	3.0	4.4	5.2	9.5	5.0	3.0
09 69 181 x230 09 69 281 x230	0.50	1.9	2.3	3.2	9.5	5.0	3.0
09 69 182 x140 09 69 282 x140	0.60	1.9	2.4	3.2	9.0	5.0	3.0
09 69 182 x230 09 69 282 x230	0.60	1.9	2.4	3.2	9.0	5.0	3.0
09 69 182 x232 09 69 282 x232	0.95	3.8	5.1	6.2	9.0	4.3	3.7
09 69 181 x233 09 69 281 x233	0.50	1.9	2.6	3.5	9.5	5.0	3.0
09 69 182 x233 09 69 282 x233	0.60	1.9	2.6	3.5	9.3	4.3	3.0

¹⁾ S4 = 0.76 µm Au or PdNi equivalent
Dimensions see pages 04.27 and 04.28
Tooling see chapter 31



Coaxial contacts for cable applications

Identification

Drawing

Dimensions in mm

Male contacts

Part No.	ø a	ø b	ø c	ø d
09 69 281 x140	0.85	1.9	2.6	3.2
09 69 281 x141	0.85	1.2	1.7	2.3
09 69 281 x230	0.50	1.9	2.6	3.2

Part No.	ø a	ø b	ø c	ø d
09 69 281 x143	1.0	3.0	4.4	5.2

Part No.	ø a	ø b	ø c	ø d
09 69 281 x233	0.5	1.9	2.6	3.5

Part No.	ø a	ø b	ø c	ø d	ø e
09 69 282 x140	0.6	1.9	2.6	3.2	3.8
09 69 282 x230	0.6	1.9	2.6	3.2	3.8
09 69 282 x233	0.6	1.9	2.6	3.5	4.4

Part No.	ø a	ø b	ø c	ø d
09 69 282 x232	0.95	3.8	5.1	6.2

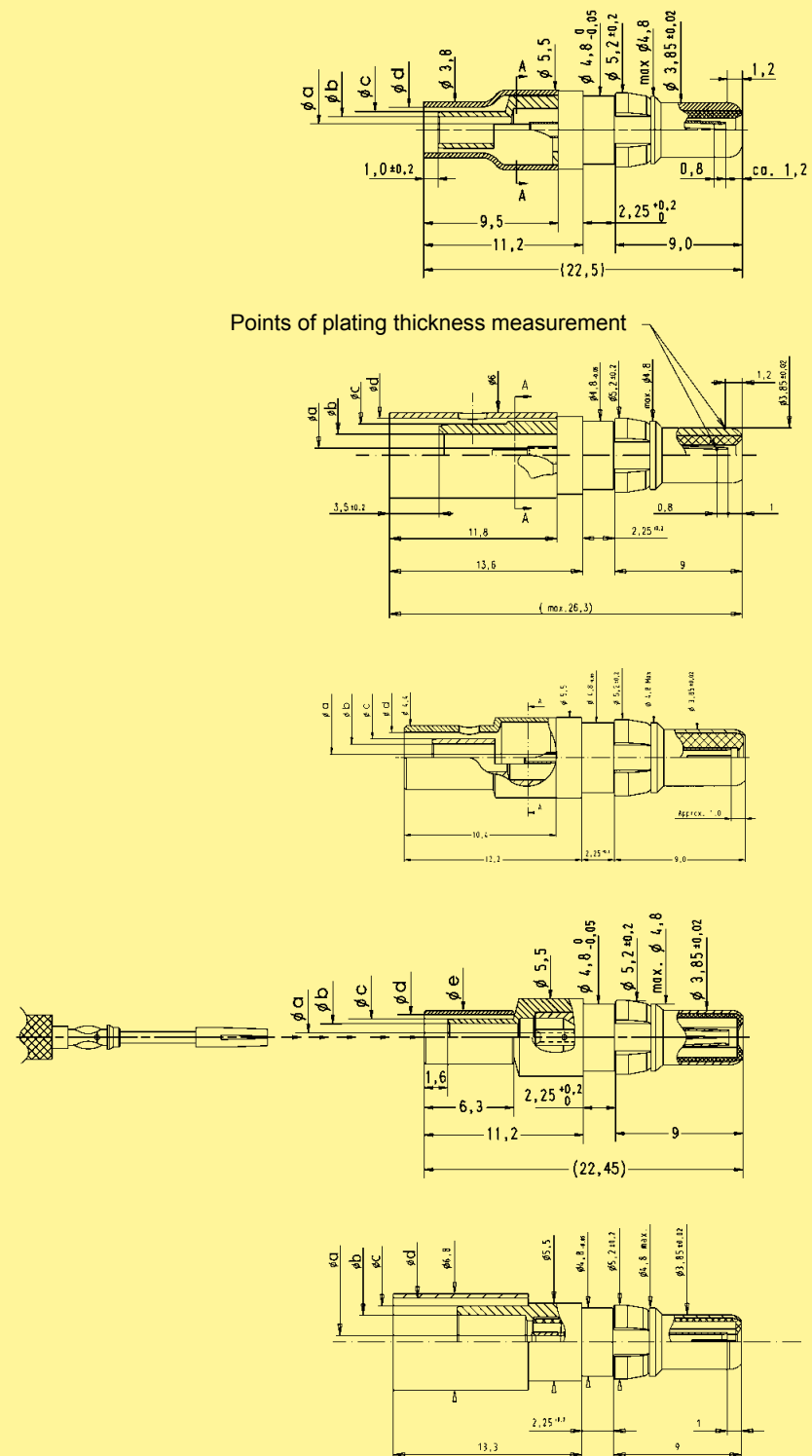

D-Sub - M



Coaxial contacts for cable applications

Identification

Drawing

Dimensions in mm

Female contacts

Part No.	ø a	ø b	ø c	ø d
09 69 181 x140	0.85	1.9	2.6	3.2
09 69 181 x141	0.85	1.2	1.7	2.3
09 69 181 x230	0.50	1.9	2.6	3.2

Part No.	ø a	ø b	ø c	ø d
09 69 181 x143	1.0	3.0	4.4	5.2

Part No.	ø a	ø b	ø c	ø d
09 69 181 x233	0.5	1.9	2.6	3.5

Part No.	ø a	ø b	ø c	ø d	ø e
09 69 182 x140	0.6	1.9	2.6	3.2	3.8
09 69 182 x230	0.6	1.9	2.6	3.2	3.8
09 69 182 x233	0.6	1.9	2.6	3.5	4.4

Part No.	ø a	ø b	ø c	ø d
09 69 182 x232	0.95	3.8	5.1	6.2

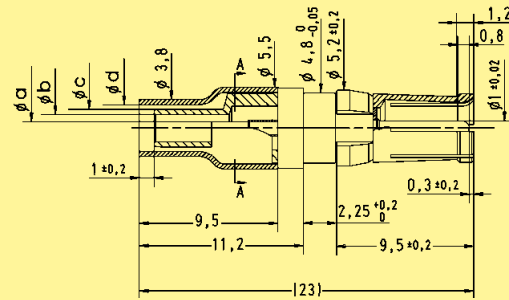

Points of plating thickness measurement

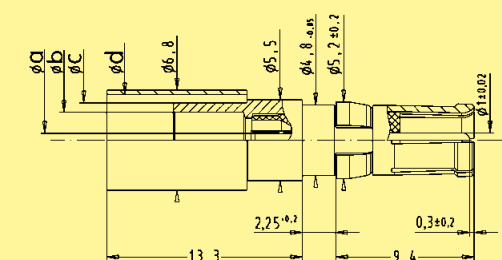
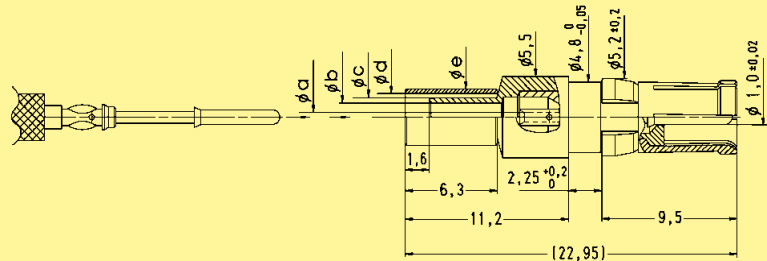
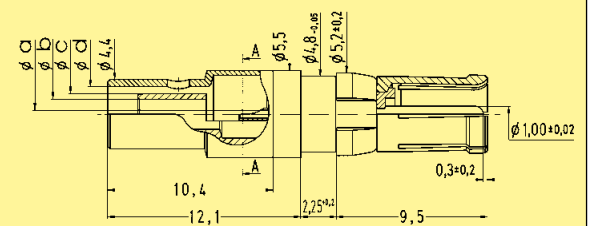
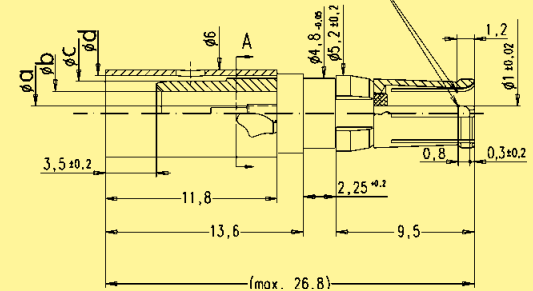

D-Sub - M

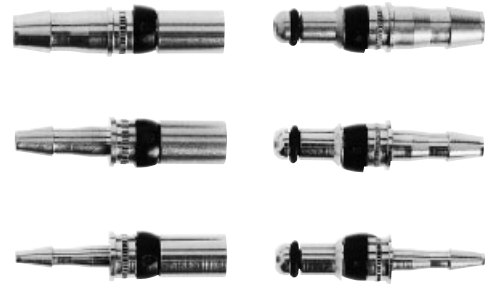

Pneumatic contacts for cable applications

Identification	Inner diameter air tube (mm)	Part No.
Male contacts	2	09 69 287 0060
	2.6	09 69 287 0061
	3	09 69 287 0062
	4	09 69 287 0063
Female contacts	2	09 69 187 0060
	2.6	09 69 187 0061
	3	09 69 187 0062
	4	09 69 187 0063

Male contacts

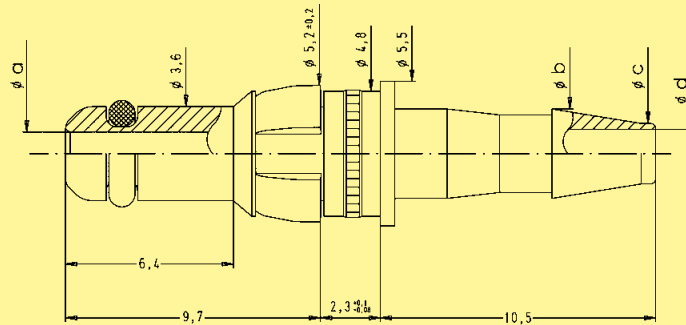

Part No.	ø a	ø b	ø c	ø d
09 69 x87 0060	1.45	2.6	1.5	0.95
09 69 x87 0061	1.65	3.1	2.0	1.65
09 69 x87 0062	1.65	3.4	2.3	1.85
09 69 x87 0063	1.65	4.8	3.7	2.95

Female contacts

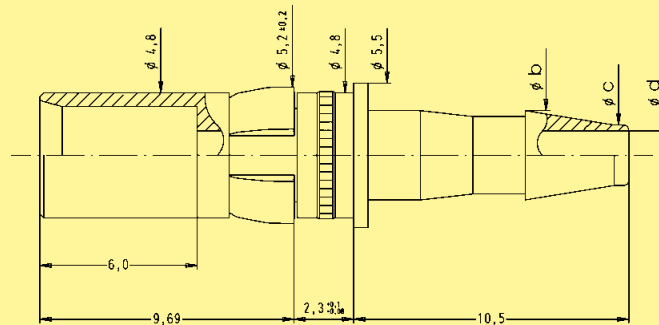

Dimensions in mm

Board drillings for connectors with straight pcb contacts

Pcb hole patterns

In the next pages, the pcb hole pattern is given for the power and the coaxial contact per connector layout. In the case of the power contact, the drilling hole dimension is not mentioned; the table here under provides relevant information according to the current rating of the contact and its version.

Power contact diameter and pcb related drilling diameter

Rating	Straight connectors		Right angled connectors	
	Pin Ø (mm)	Pcb drilling Ø (mm)	Pin Ø (mm)	Pcb drilling Ø (mm)
20 A	2.60	2.9	2.85	3.15
30 A	–	–	3.20	3.50
40 A	3.75	4.0	3.75	4.05

D-Sub - M

Identification Drawing Dimensions in mm

Male connector*

Power contact

Coaxial contact

2W2 / 2W2C

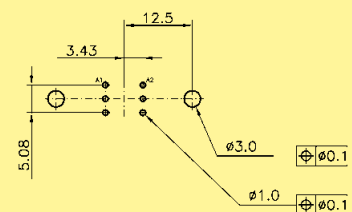
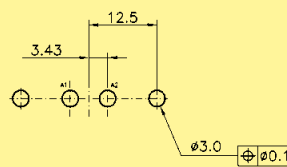

3W3 / 3W3C

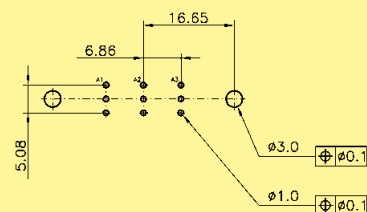
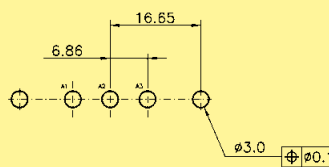

5W1

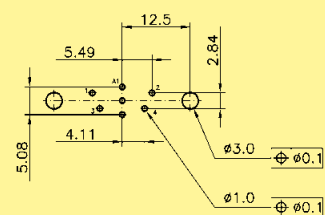
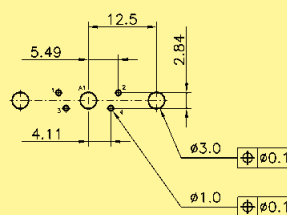

5W5

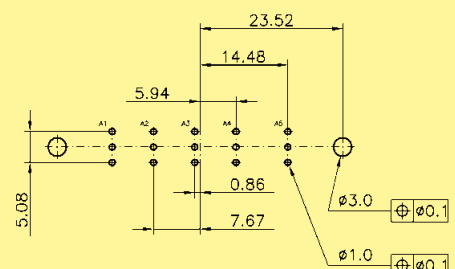
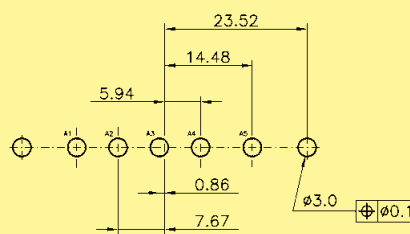

7W2

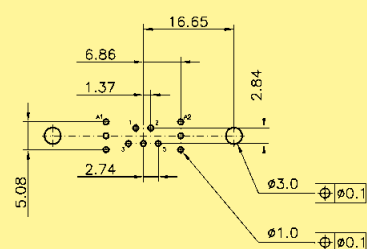
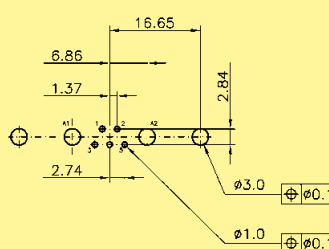

* When using a female connector with straight pcb contacts the board drilling pattern must be mirrored in the Y axis.

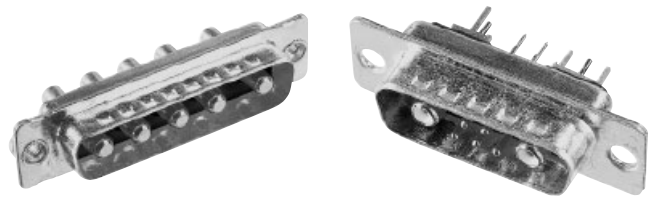

Board drillings for connectors with straight pcb contacts

Identification

Drawing

Dimensions in mm

Male connector*

Power contact

Coaxial contact

7W7

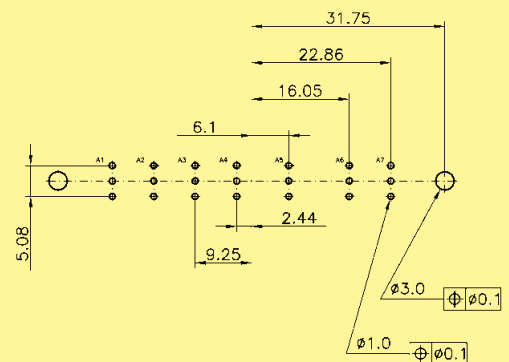
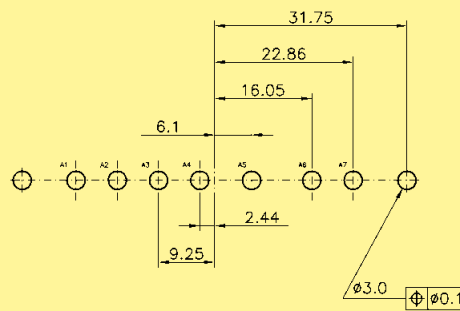

8W8

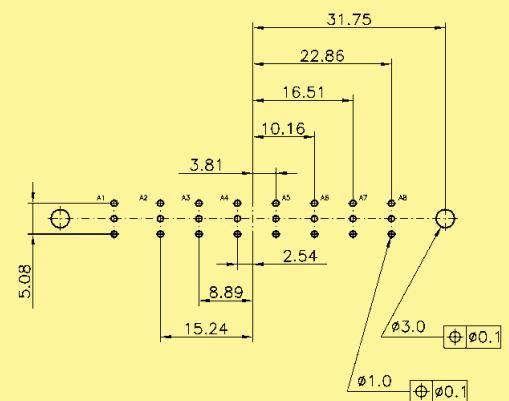
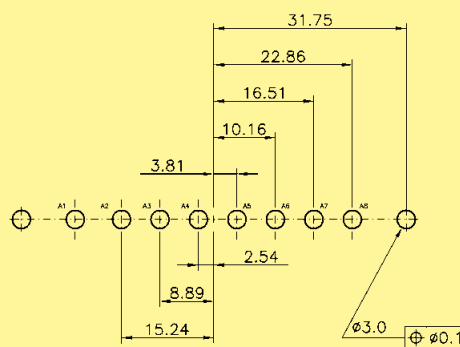

9W4

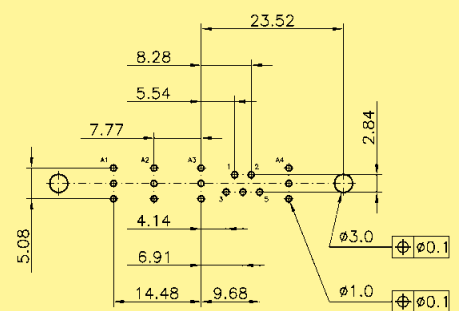
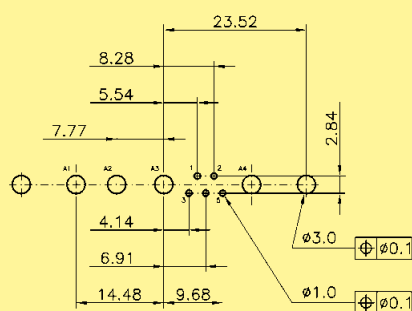

11W1

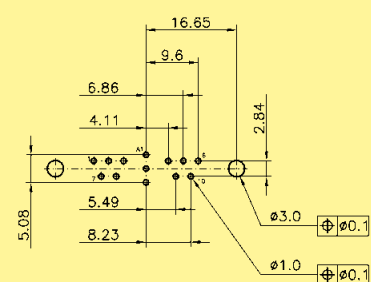
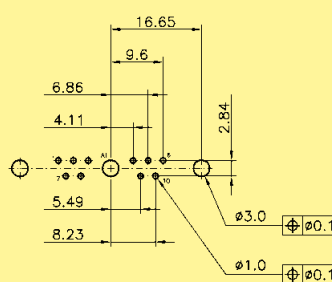

D-Sub - M

* When using a female connector with straight pcb contacts the board drilling pattern must be mirrored in the Y axis.

Board drillings for connectors with straight pcb contacts

Identification

Drawing

Dimensions in mm

Male connector*

13W3

Power contact

Coaxial contact

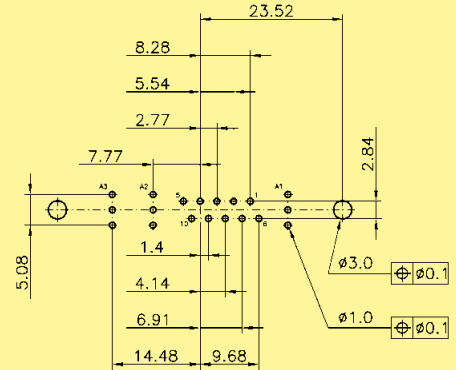
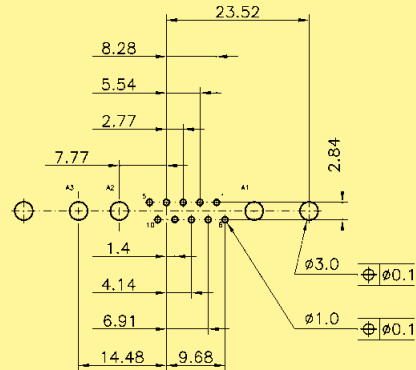

13W6

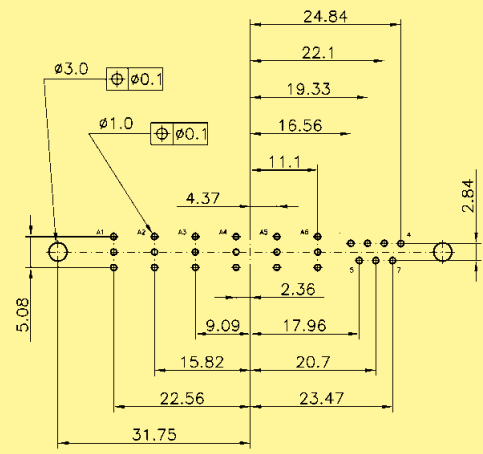
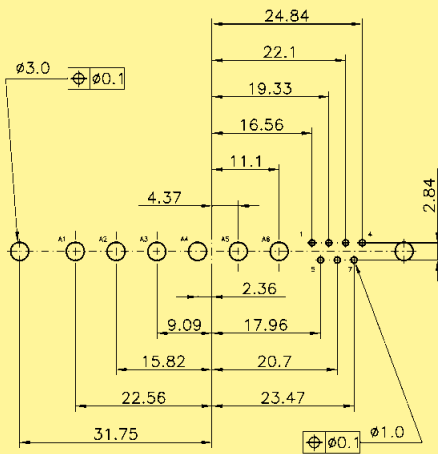

17W2

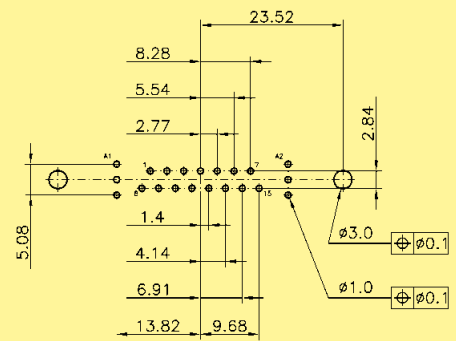
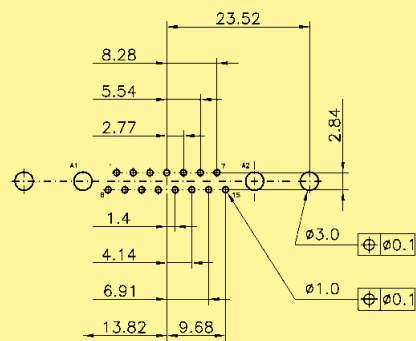

21W1

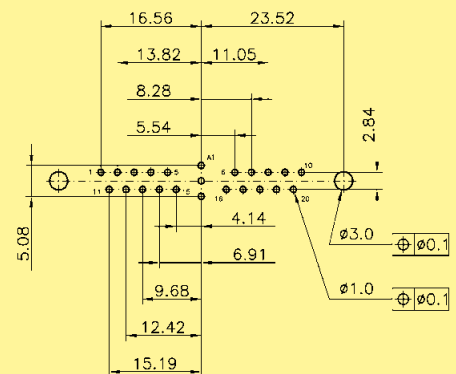
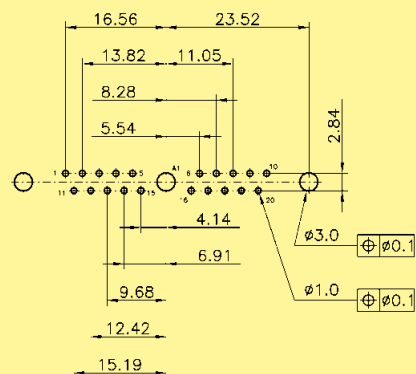

D-Sub - M

* When using a female connector with straight pcb contacts the board drilling pattern must be mirrored in the Y axis.

Board drillings for connectors with straight pcb contacts

Identification	Drawing	Dimensions in mm
<p>Male connector*</p> <p>21WA4</p>	<p style="text-align: center;">Power contact</p>	<p style="text-align: center;">Coaxial contact</p>
<p>24W7</p>		
<p>25W3</p>		

D-Sub - M

* When using a female connector with straight pcb contacts the board drilling pattern must be mirrored in the Y axis.

Board drillings for connectors with straight pcb contacts

Identification

Drawing

Dimensions in mm

Male connector*

27W2

Power contact

Coaxial contact

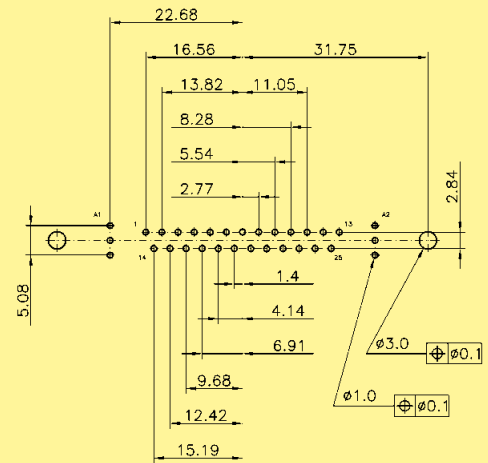
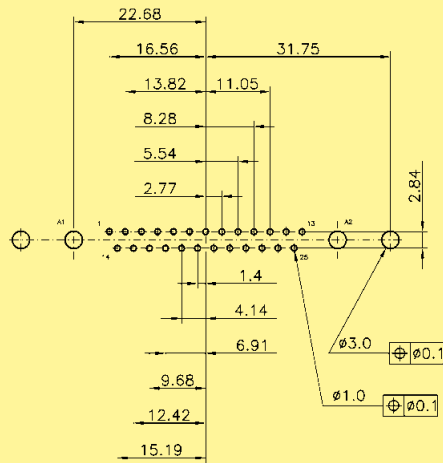

36W4

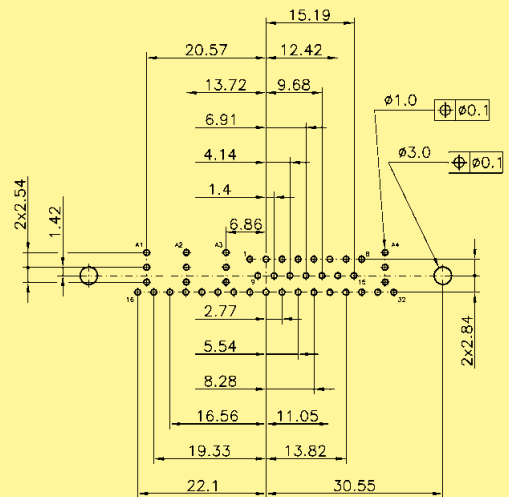
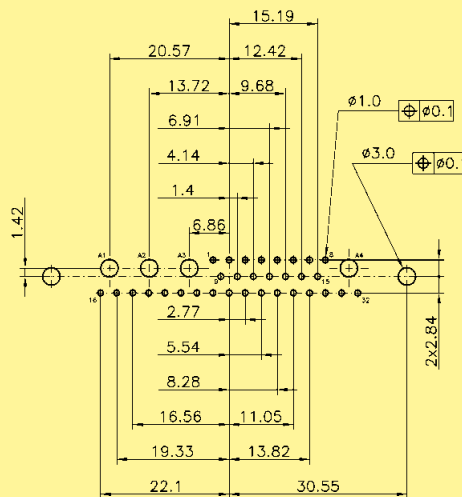

43W2

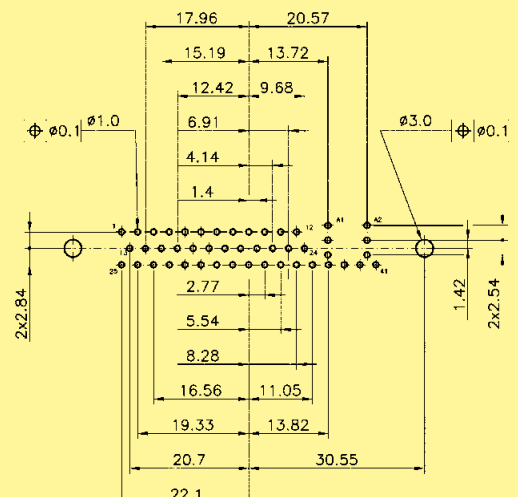
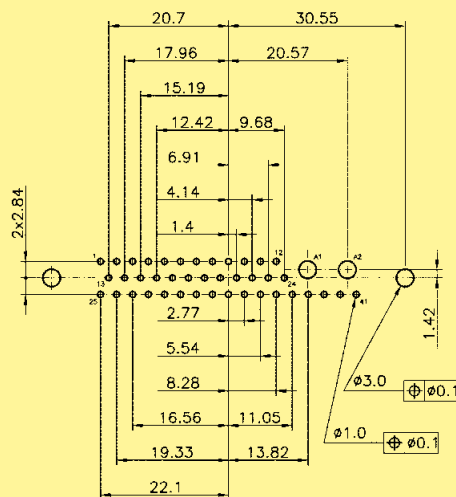

D-Sub - M

* When using a female connector with straight pcb contacts the board drilling pattern must be mirrored in the Y axis.



Board drillings for connectors with right angled pcb contacts

Identification

Drawing

Dimensions in mm

Male connector*

Power contact

Coaxial contact

2W2 / 2W2C

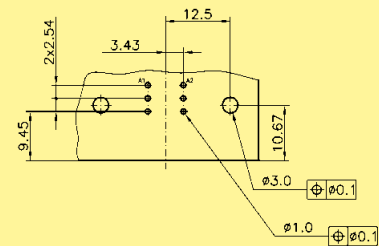
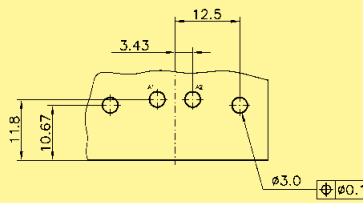

3W3 / 3W3C

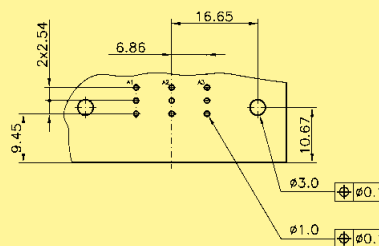
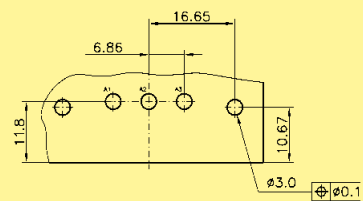

5W1

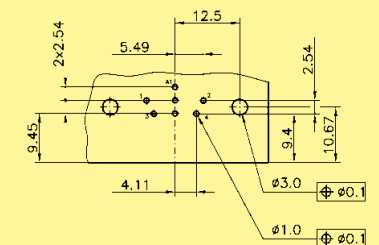
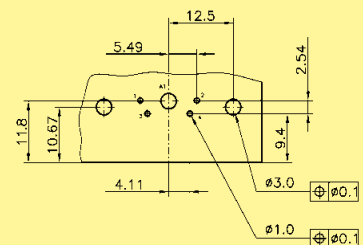

5W5

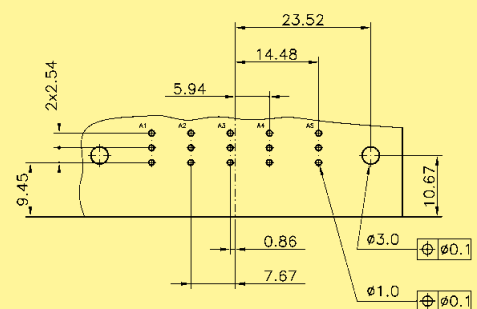
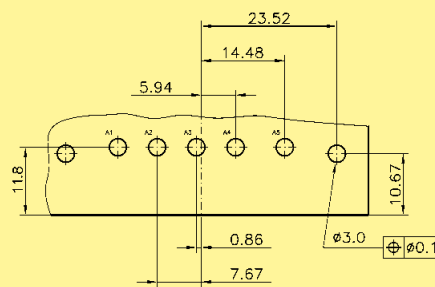

7W2

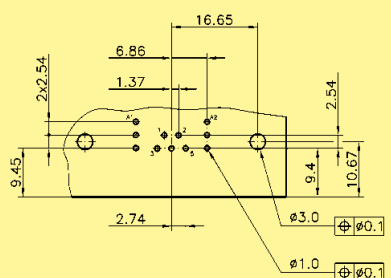
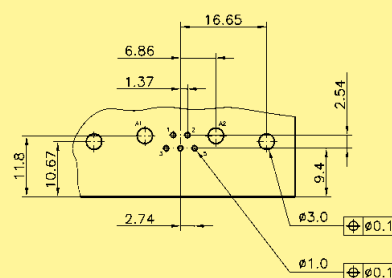

* When using a female connector with right angled pcb contacts the board drilling pattern must be mirrored in the Y axis.

Board drillings for connectors with right angled pcb contacts

Identification

Drawing

Dimensions in mm

Male connector*

7W7

Power contact

Coaxial contact

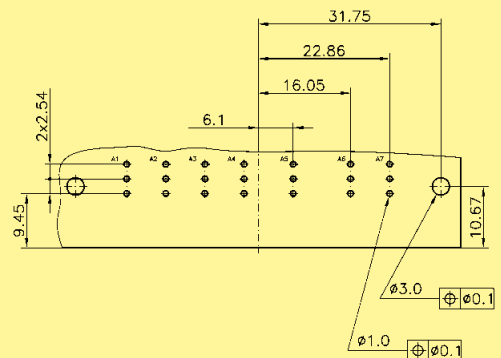
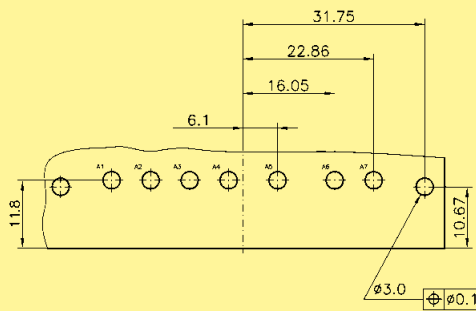

8W8

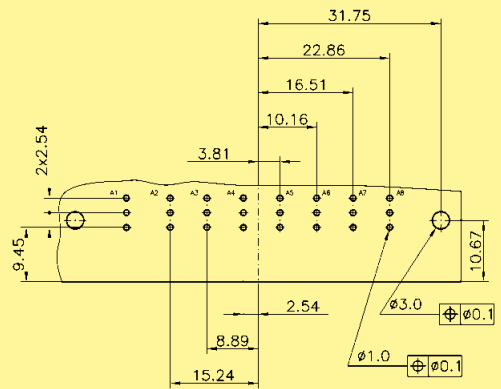
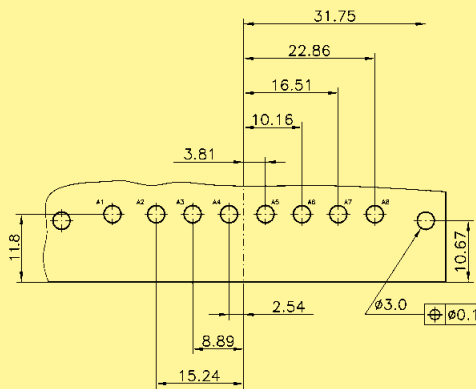

9W4

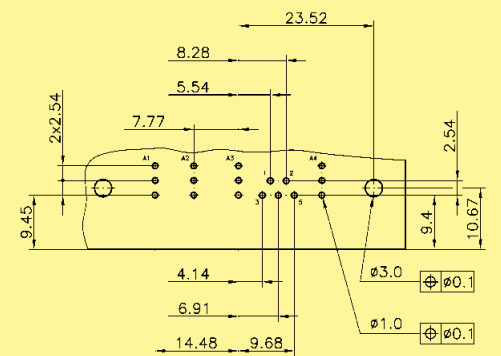
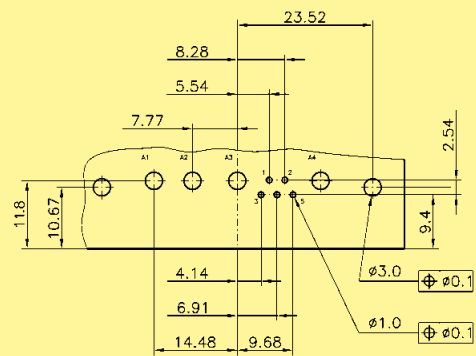

11W1

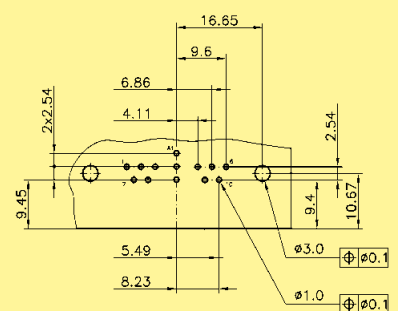
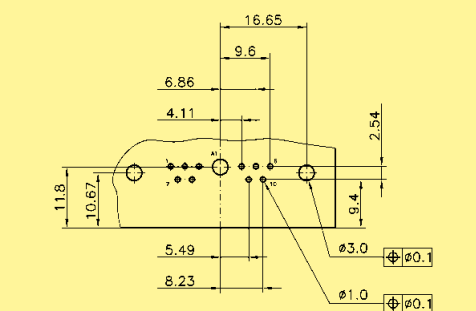

D-Sub - M

* When using a female connector with right angled pcb contacts the board drilling pattern must be mirrored in the Y axis.

Board drillings for connectors with right angled pcb contacts

Identification	Drawing	Dimensions in mm
Male connector*		
13W3	<p style="text-align: center;">Power contact</p>	<p style="text-align: center;">Coaxial contact</p>
13W6		
17W2		
21W1		

* When using a female connector with right angled pcb contacts the board drilling pattern must be mirrored in the Y axis.

Board drillings for connectors with right angled pcb contacts

Identification

Drawing

Dimensions in mm

Male connector*

21WA4

Power contact

Coaxial contact

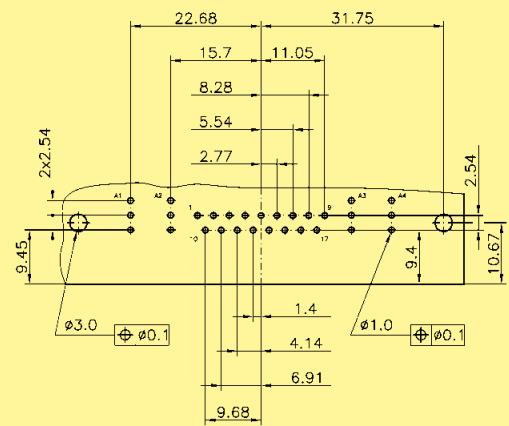
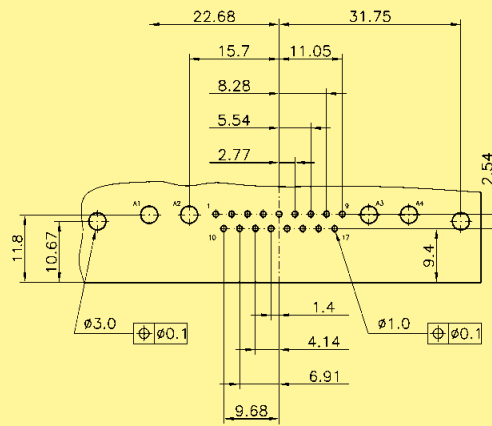

24W7

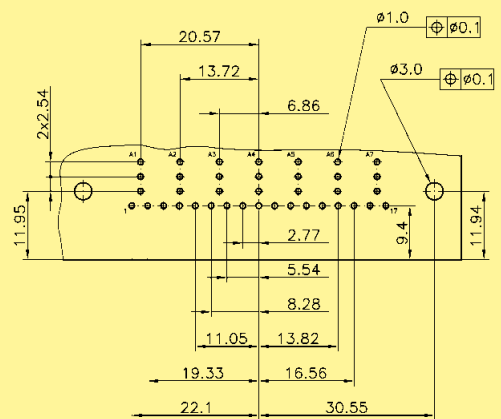
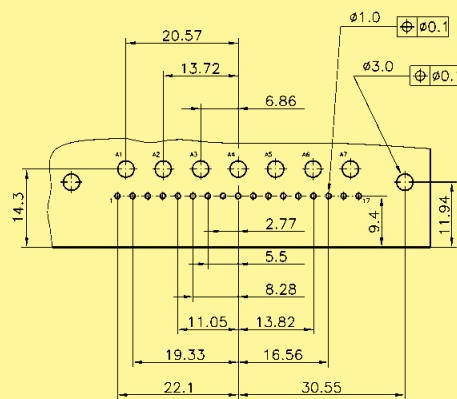

25W3

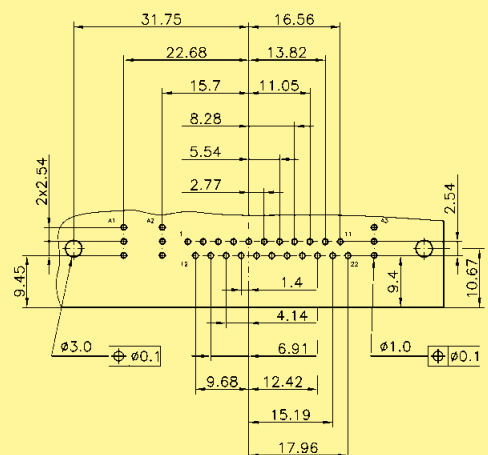
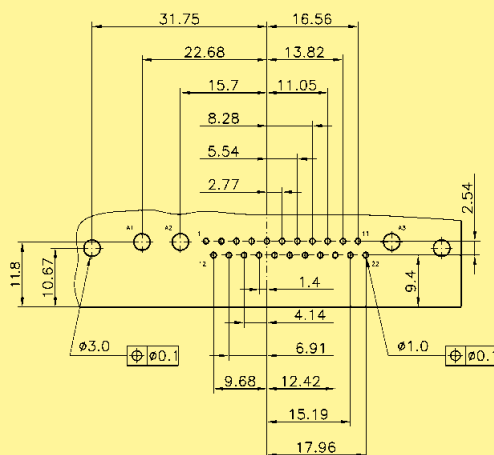

D-Sub - M

* When using a female connector with right angled pcb contacts the board drilling pattern must be mirrored in the Y axis.

Board drillings for connectors with right angled pcb contacts

Identification

Drawing

Dimensions in mm

Male connector*

27W2

Power contact

Coaxial contact

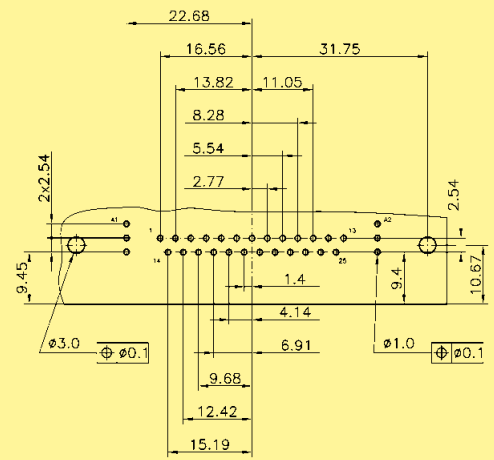
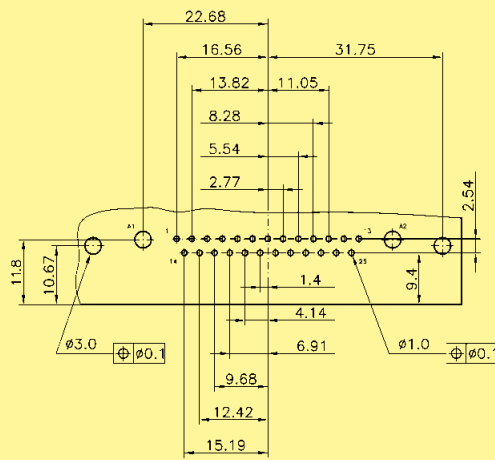

36W4

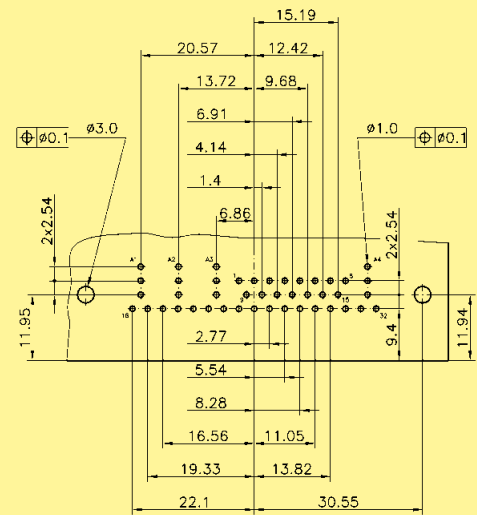
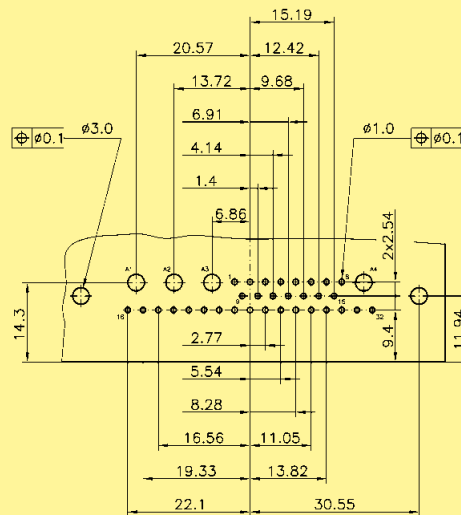

43W2

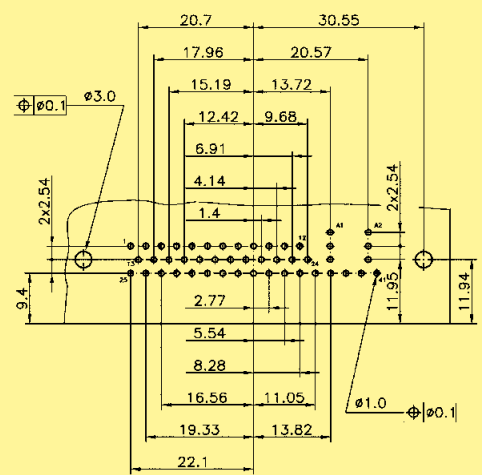
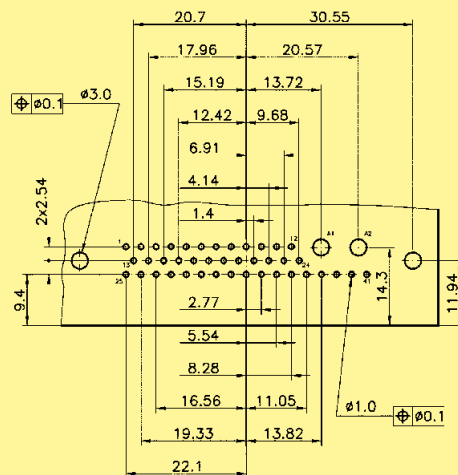

* When using a female connector with right angled pcb contacts the board drilling pattern must be mirrored in the Y axis.

HARTING customer request form for pcb connectors

1 Connector gender and type

- Plug (male contacts)
- Receptacle (female contacts)

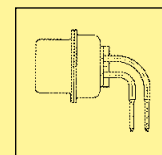
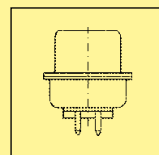

- Straight
- Right angled

2 Contact arrangement

Standard

- | | | | |
|------------------------------|-------------------------------|--------------------------------|-------------------------------|
| <input type="checkbox"/> 2W2 | <input type="checkbox"/> 7W7 | <input type="checkbox"/> 13W6 | <input type="checkbox"/> 25W3 |
| <input type="checkbox"/> 3W3 | <input type="checkbox"/> 8W8 | <input type="checkbox"/> 17W2 | <input type="checkbox"/> 27W2 |
| <input type="checkbox"/> 5W1 | <input type="checkbox"/> 9W4 | <input type="checkbox"/> 21W1 | <input type="checkbox"/> 36W4 |
| <input type="checkbox"/> 5W5 | <input type="checkbox"/> 11W1 | <input type="checkbox"/> 21WA4 | <input type="checkbox"/> 43W2 |
| <input type="checkbox"/> 7W2 | <input type="checkbox"/> 13W3 | <input type="checkbox"/> 24W7 | |

Special configurations
(mixed contact genders)

- 2W2C
- 3W3C

2.1 Any signal contacts?

- Yes (fill in questions below) No (go directly to item 2.2)
- Right angled 2.54 mm pitch
- Other pitch: _____

2.2 Any power contacts?

Current rating

- Yes (fill in questions below) No (go directly to item 2.3)
- 10 A 30 A
- 20 A 40 A

Termination type

- Solder pin for pcb
- Press-in for pcb (30 A, straight version only)

Performance level
[mating side / termination side]

- S4 [0.76 µm Au / 0.2 µm Au]
- PL 3 [0.2 µm Au / 5.0 µm Sn]

2.3 Any coaxial contacts?

Impedance

- Yes (fill in questions below) No (go directly to item 2.4)
- 50 Ω
- 75 Ω
- Performance level [mating side inner / outer conductor]
 - S4 [1.3 µm Au / 0.76 µm Au]
 - PL 3 [0.2 µm Au / 0.2 µm Au]

2.4 Any high voltage contacts?

- Yes No (go directly to item 2.5)

2.5 Any pneumatic contacts?

Tube inner diameter /
suitable compressed air tube

- Yes (fill in questions below) No (go directly to item 3)
- 2 mm / PU-2 2.6 mm / PU-N4* 2.5
- 3 mm / PU-3 4 mm / PU-4

D-Sub - M

HARTING customer request form for pcb connectors

3 Pcb mounting accessories (select appropriate fixing accessories)

3.1 Right angled version

- Through hole
 - Nut 4-40 UNC
 - Nut M3
 - Metal bracket
 - Snap clip
 - Screw lock
 - fixed removable
 - 4-40 UNC M3
-

3.2 Straight version

- Through hole
 - Nut 4-40 UNC
 - Nut M3
 - Spacer 4-40 UNC
 - Spacer M3
 - Screw lock 4-40 UNC
 - Spacer 4-40 UNC + clip
 - Spacer M3 + clip
 - Spacer + clip and screw lock
 - M3 4-40 UNC
-

4 Additional information

Pcb thickness:

(if possible provide pcb layout with plating specifications)

Operating temperature:

- standard
- SMC compatible

Is hot plugging required

- No
- Yes

Short description: _____

Is a vacuum pick and place process considered?

- No
- Yes

Is blind mating feature required?

- No
- Yes (provide precise requirements)

Name: _____

Drawing: no yes

Company: _____

Samples: no yes, quantity

Address: _____

Volume (pcs./year): _____

Phone: _____

Special requirements: _____

Fax: _____

E-Mail: _____

HARTING customer request form for cable connectors

1 Connector gender

- Plug (male contacts)
 Receptacle (female contacts)



21W4 mixed male for cable

2 Contact arrangement

Standard

- | | | | |
|------------------------------|-------------------------------|--------------------------------|-------------------------------|
| <input type="checkbox"/> 2W2 | <input type="checkbox"/> 7W7 | <input type="checkbox"/> 13W6 | <input type="checkbox"/> 25W3 |
| <input type="checkbox"/> 3W3 | <input type="checkbox"/> 8W8 | <input type="checkbox"/> 17W2 | <input type="checkbox"/> 27W2 |
| <input type="checkbox"/> 5W1 | <input type="checkbox"/> 9W4 | <input type="checkbox"/> 21W1 | <input type="checkbox"/> 36W4 |
| <input type="checkbox"/> 5W5 | <input type="checkbox"/> 11W1 | <input type="checkbox"/> 21WA4 | <input type="checkbox"/> 43W2 |
| <input type="checkbox"/> 7W2 | <input type="checkbox"/> 13W3 | <input type="checkbox"/> 24W7 | |

Special configurations
(mixed contact genders)

- 2W2C 3W3C

2.1 Any signal contacts?

- Yes (fill in questions below) No (go directly to item 2.2)

Termination type

- Crimp Solder cup S4 [0.76 μ m Au]

Signal cable size for crimp contact

- AWG 20-24 AWG 24-28

Crimp contact performance level

- S4 [0.76 μ m Au / 0.2 μ m Au]
 PL3 [0.2 μ m Au / 5.0 μ m Sn]

2.2 Any power contacts?

- Yes (fill in questions below) No (go directly to item 2.3)

Current rating

- 10 A 20 A 30 A 40 A

Termination type

- Crimp Solder cup

Performance level

[mating side / termination side]

- S4 [0.76 μ m Au / 0.2 μ m Au]
 PL3 [0.2 μ m Au / 5.0 μ m Sn]

2.3 Any coaxial contacts?

- Yes (fill in questions below) No (go directly to item 2.4)

Impedance

- 50 Ω 75 Ω

Termination type

- Crimp/crimp
 Crimp/solder [inner conductor is soldered, outer crimped]

Performance level

[mating side inner / outer conductor]

- S4 [1.3 μ m Au / 0.76 μ m Au]
 PL3 [0.2 μ m Au / 0.2 μ m Au]

Cable reference (e.g. RG 178): _____

HARTING customer request form for cable connectors

2.4 Any high voltage contacts? Yes No (go directly to item 2.5)
 Termination type Crimp Solder cup

2.5 Any pneumatic contacts? Yes (fill in questions below) No (go directly to item 3)
 Tube inner diameter /
 suitable compressed air tube 2 mm / PU-2 2.6 mm / PU-N4* 2.5
 3 mm / PU-3 4 mm / PU-4

3 Cable accessories

HARTING has a wide range of hoods including plastic, metallized plastic and full metal versions.

Name: _____ Drawing: no yes
 Company: _____ Samples: no yes, quantity
 Address: _____ Volume (pcs./year): _____

 Phone: _____ Special requirements: _____
 Fax: _____
 E-Mail: _____

D-Sub – Filter subminiature D connectors, 2.54 mm pitch

Page

General information  **05.02**

Ferrite-filter

Technical characteristics **05.03**

Connectors with solder pins, straight  **05.04**

Connectors with solder pins, right angled (US footprint 2.84 mm)  **05.05**

Connectors with solder buckets  **05.06**

C-filter

Technical characteristics **05.07**

Attenuation characteristics for standard capacitance values **05.08**

Filter adapters  **05.09**

Connectors with turned solder pins, straight  **05.10**

Connectors with turned solder pins, right angled (European footprint 2.54 mm)  **05.16**

Connectors with solder buckets  **05.28**

Panel cut outs / panel mountings **05.32**

Customized solutions

General information **05.33**

HARTING customer request form  **05.36**

Interference – Yesterdays problem!

In a fast developing technological environment the management of electromagnetic interference is becoming more challenging.

Therefore HARTING developed a range of filter solutions to help designers of electronic equipments to achieve the demanding goal of electromagnetic compatibility.

HARTING offers a wide range of solutions by the integration of a filter inside one of the most standard I/O ports on the market; the D-Sub.

From standard simple ferrite-filter solution to complex customized high performance filters, you will be able to find in the HARTING filter D-Sub range the adequate solution to protect your application from any introduction or radiation of noise through D-Sub port apertures.

Advantages

Wide range:

- 9, 15, 25 and 37 contact versions
- Various terminations such as solder buckets, straight and right angled solder pins
- A large range of accessories
- High performance (C-filter) as well as simple, quick and cost effective solutions (ferrite-filter)

Compatible with standard wave and lead-free reflow soldering (C-filter)

Same layout and shell dimensions as standard D-Sub connectors, no modification of PCB design necessary

Elimination of ringing, crosstalk phenomenon thanks to specific multilayer PCB used in C-filter design.

Flexible filter structure allowing a wide range of customization:

- Filter value (even pin by pin approach)
- Pi-filter
- Dielectric withstanding and working voltage
- Specific ESD / lightning protection

HARTINGs broad Filter range

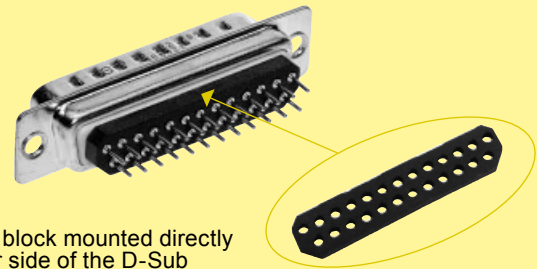

Ferrite block mounted directly on rear side of the D-Sub

Ferrite-filter

Ferrite-filter D-Subs providing a low level of filtering thanks to simple blocks of inductive ferrite attached to the back end of the connectors. Providing a few dB attenuation only at high frequencies HARTING ferrite-filter D-Subs represent a cost effective solution in applications where the emission level is close to the limit.

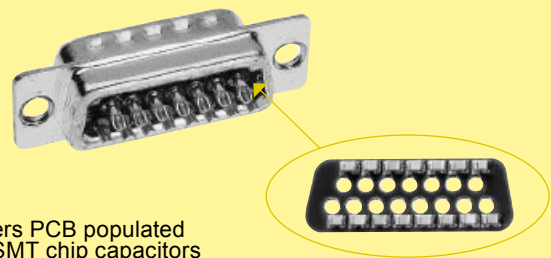

4 layers PCB populated with SMT chip capacitors

C-filter

To address higher EMI disturbances HARTING propose a comprehensive range of C-filter D-Sub connectors. HARTING C-filter D-Sub integrates a patented 4 layer printed circuit board equipped with chip capacitors. This patented solution provides complete protection of the I/O port due to the filtering performance of the capacitors and the screening effect of the PCB. Further more the 4 layers PCB also limits the ability of interference to enter the equipment through the D-Sub aperture. Available in 4 standard filter values 47, 470, 1000 and 3900 pF HARTING C-filter D-Subs represent for all designers a smart filtering solution allowing replacement of a “defective” port by a filtered one without any change of the PCB design.

Filter adapter

To support engineers in the diagnosis of EMI disturbances HARTING has developed, in addition to its filter series a range of male/female filter D-Sub adapters.

These back-to-back adapters can be used as testing tools and replaced later on in production directly by a filtered D-Sub connector.

Number of contacts	9, 15, 25, 37
Working current	7.5 A max.
Working voltage	250 V AC max.
Dielectric withstanding voltage	500 V AC for 1 minute
Contact resistance	≤ 15 mΩ
Insulation resistance	≥ 1000 MΩ
Temperature range	-55 °C ... + 105 °C
Terminations	a) Solder buckets AWG 20 b) Solder pins for P.C.B. holes Ø 1 ± 0.05 mm c) Solder pins, angled 90° for P.C.B. holes Ø 1 ± 0.05 mm
Materials	
Insulation	PBT, flame retardant acc. to UL 94-V0
Contacts	Copper alloy
Contact surface	
Performance level	Performance level 3, as per IEC 60807-2, IEC 60512-25-2
Metal shell	Steel (tin-plated)

Contact arrangement
View from termination side

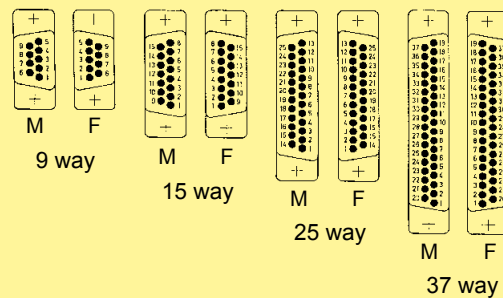

M = Male connector
F = Female connector

Mating conditions as per CECC 75 301

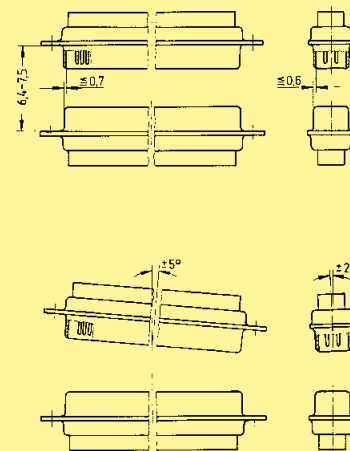

Minimum insertion loss

Frequency [MHz]	Attenuation [dB]
1	0.5
10	1.0
50	2.5
100	3.0
500	3.5
1000	4.0

Number of contacts

9-25

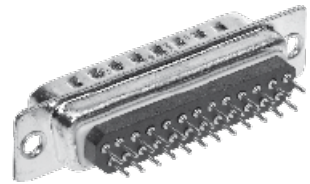
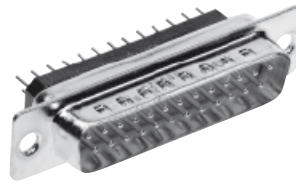

Solder pins, straight, through hole

Identification	No. of contacts	Part No.
Connectors with ferrite-filter		male connectors
		female connectors
	9	09 64 122 7800
	15	09 64 222 7800
	25	09 64 322 7800

Male connector

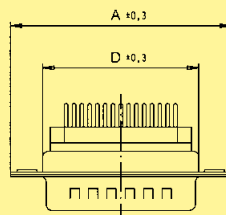
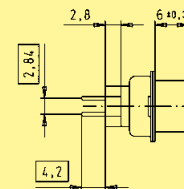
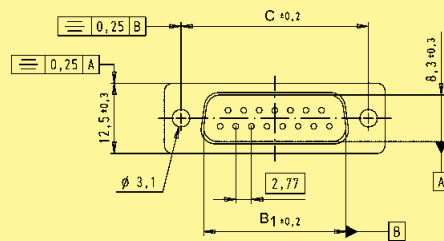

No. of contacts	A	B ₁	B ₂	C	D
9	30.8	16.92	16.3	25.0	19.2
15	39.2	25.25	24.6	33.3	27.7
25	53.1	38.96	38.3	47.1	41.1

Female connector

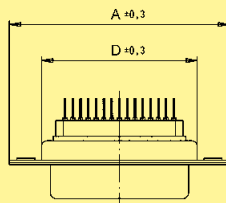
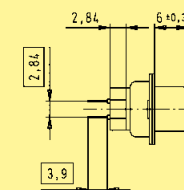
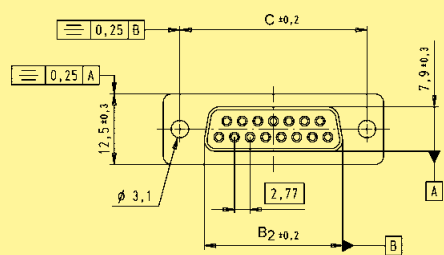

Board drillings

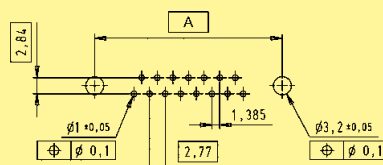

Dimensions in mm

D-Sub



Number of contacts

9-37

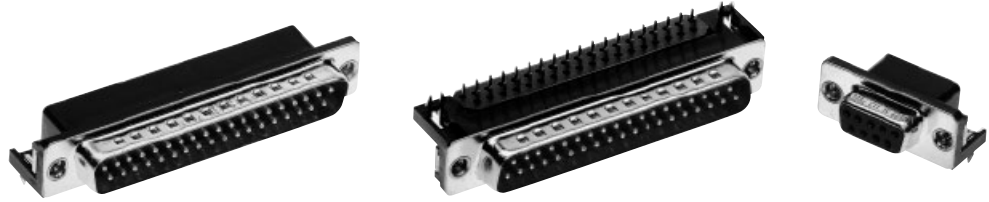

Solder pins, right angled, board lock and clinch nut

Identification	No. of contacts	Part No.
Connectors with ferrite-filter		male connectors
		female connectors
	9	09 64 123 7802
	15	09 64 223 7802
	25	09 64 323 7802
	37	09 64 423 7802

Male connector

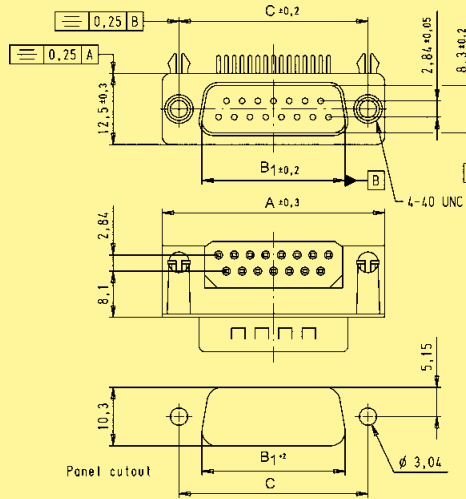

No. of contacts	A	B ₁	B ₂	C	E	F
9	30.8	16.92	16.3	25.0	3	4
15	39.2	25.25	24.6	33.3	6	7
25	53.1	38.96	38.3	47.1	11	12
37	69.4	55.42	54.8	63.5	17	18

Female connector

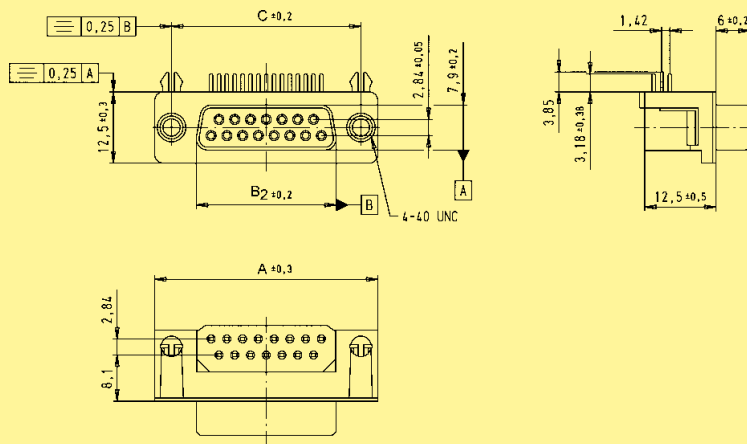

Board drillings

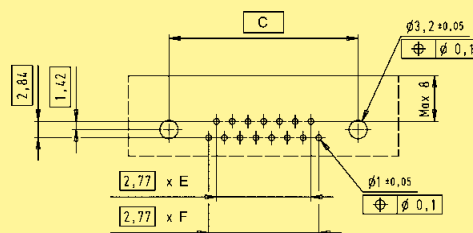

Dimensions in mm

Number of contacts

9-37



Solder buckets, through hole

Identification	No. of contacts	Part No.	
		male connectors	female connectors
Connectors with ferrite-filter	9	09 64 121 7800	09 64 111 7800
	15	09 64 221 7800	09 64 211 7800
	25	09 64 321 7800	09 64 311 7800
	37	09 64 421 7800	09 64 411 7800

Male connector

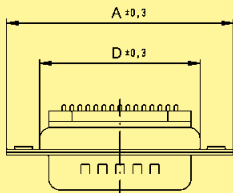
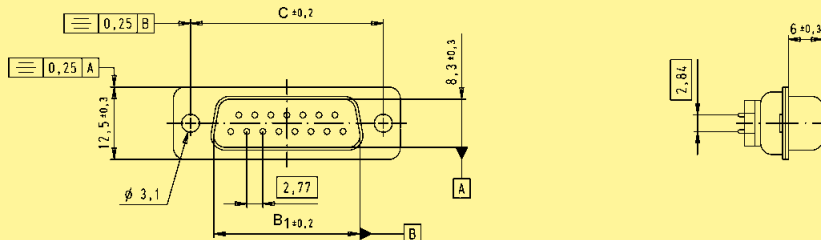

No. of contacts	A	B ₁	B ₂	C	D
9	30.8	16.92	16.3	25.0	19.2
15	39.2	25.25	24.6	33.3	27.7
25	53.1	38.96	38.3	47.1	41.1
37	69.4	55.42	54.8	63.5	57.3

Female connector

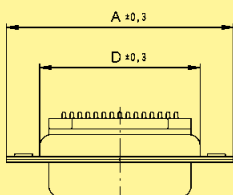
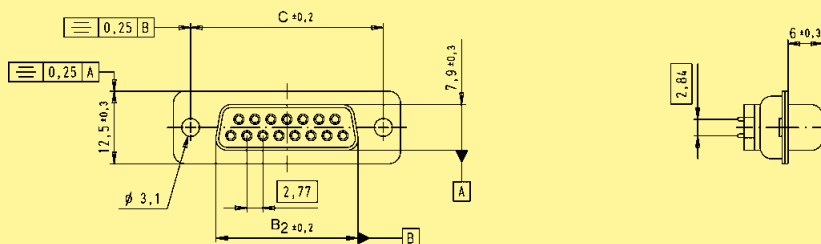

Dimensions in mm

Number of contacts	9, 15, 25, 37
Working current	7.5 A max. (connectors) 6.5 A max. (filter adapters)
Working voltage	100 V max. for standard capacitance values – higher working voltages are available as specific.
Dielectric withstanding voltage	250 V DC max. – higher dielectric withstanding voltages are available as specific (see page 05.34)
Contact resistance	≤ 10 mΩ
Insulation resistance	≥ 1000 MΩ
Temperature range	-55 °C ... + 125 °C (connectors) Heat deflection temperature limit according to DIN 53461: + 255 °C -20 °C ... + 125 °C (filter adapters)
Terminations	a) Solder buckets max. 0.8 mm ² b) Solder pins Ø 0.6 mm for P.C.B. holes Ø 0.8/1 mm c) Solder pins, angled 90° Ø 0.6 mm for P.C.B. holes Ø 0.8/1 mm
Materials	Insulation: PCT, glass-fibre filled, flame retardant acc. to UL 94-V0 Colour: natural Contacts: Copper alloy Male and female contacts are turned
Contact surface	Contact zone: Selectively plated according to performance level
Performance level	Performance level 2, as per CECC 75 301-802, 250 mating cycles, 4 days 4 mixed gas test – IEC 60512
Metal shell	Steel

Contact arrangement
View from termination side

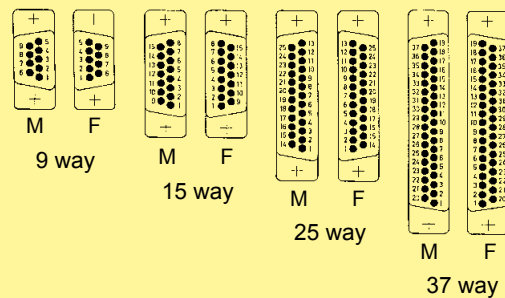

M = Male connector
F = Female connector

Mating conditions as per CECC 75 301

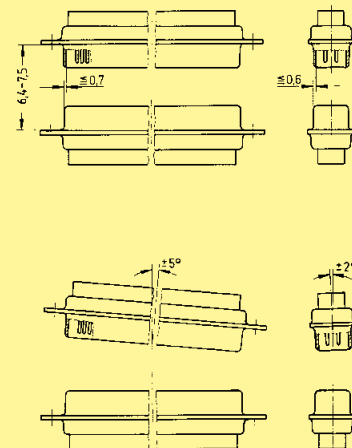

Attenuation characteristics for standard capacitance values

Min. insertion loss

Capacitance [pF] ¹⁾	Frequency [MHz]	Attenuation (in dB) vs. frequency [MHz]						
		1	5	10	50	100	500	1000
47							30	35
470				1	11	16	35	32
1000			1	3	12	24	38	30
3900		1	6	11	25	35	38	32

¹⁾ Capacitance tolerance = ± 20 % (For other capacitor values see pages 05.34 ff).

Measured in 50 Ω system according to MIL-STD-220, no load.

Working voltage: 100 V max. for standard capacitance values – higher working voltages are available as specific.

Dielectric withstanding voltage: 250 V DC max. – higher dielectric withstanding voltages are available as specific (see page 05.34)

Typical insertion loss for different filters (measured)

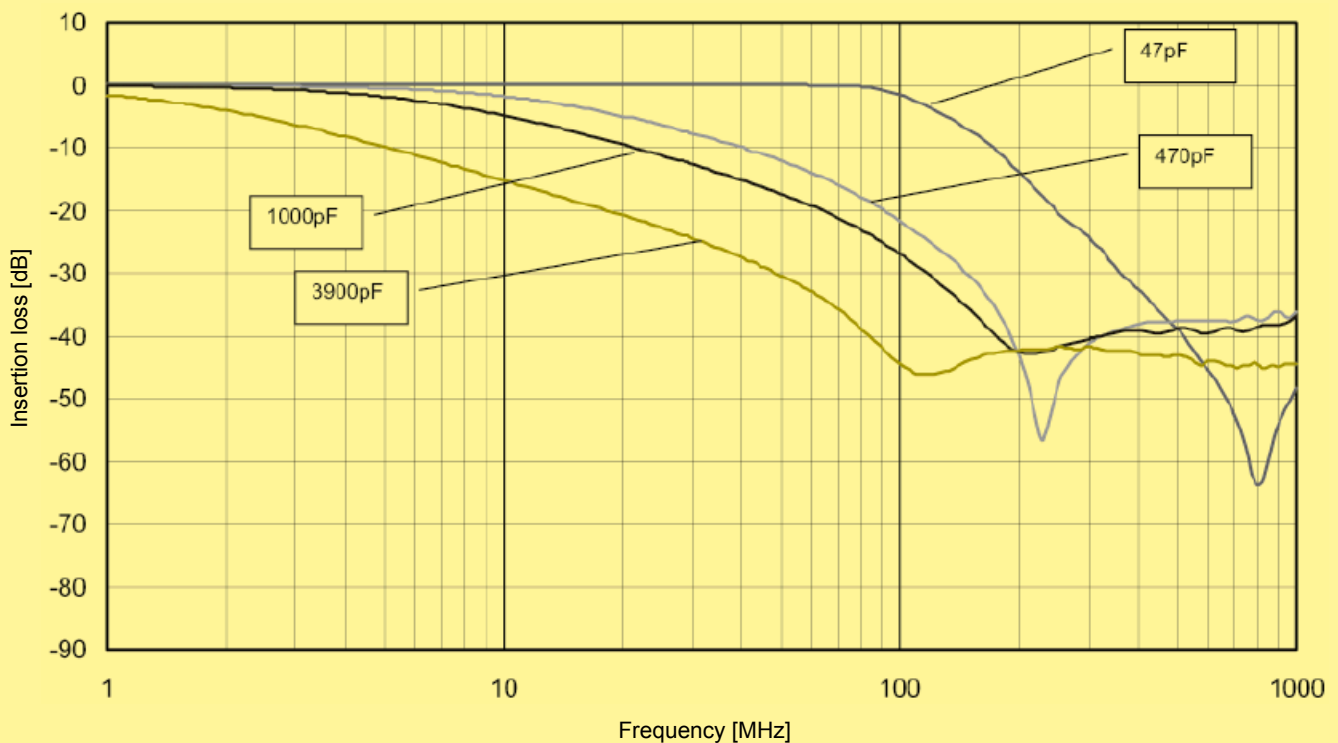

Number of contacts

9-37



Filter adapters

Identification	No. of contacts	Part No.
Male / female filter adapters with C-filter	9	09 64 100 72 ...
	15	09 64 200 72 ...
	25	09 64 300 72 ...
	37	09 64 400 72 ...
Please insert digit for capacitance	47 pF ▶	10
	470 pF ▶	20
	1000 pF ▶	30
	3900 pF ▶	40

Dimensions

	A	B
9	32.8	24.99
15	41.1	33.32
25	55.0	47.04
37	71.3	63.50

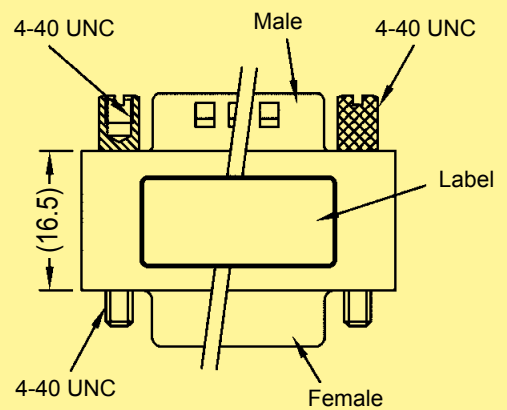
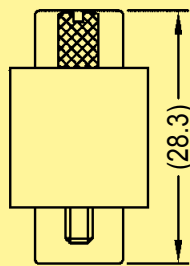
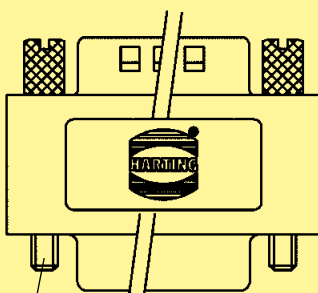
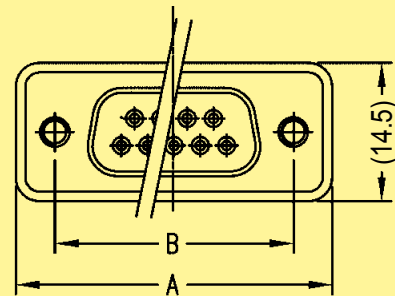

Screws are not pre-mounted to allow mounting from any ends

Number of contacts

9-37

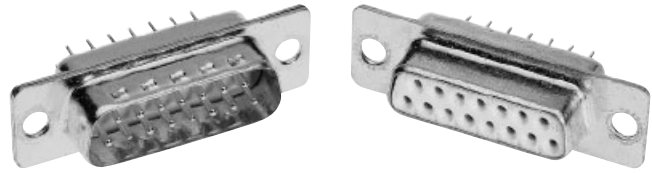

Turned solder pins, straight, through hole

Identification	No. of contacts	Part No.	
		male connectors	female connectors
Connectors with 47 pF C-filter	9	09 64 122 7210	09 64 112 7210
	15	09 64 222 7210	09 64 212 7210
	25	09 64 322 7210	09 64 312 7210
	37	09 64 422 7210	09 64 412 7210
Connectors with 470 pF C-filter	9	09 64 122 7220	09 64 112 7220
	15	09 64 222 7220	09 64 212 7220
	25	09 64 322 7220	09 64 312 7220
	37	09 64 422 7220	09 64 412 7220
Connectors with 1000 pF C-filter	9	09 64 122 7230	09 64 112 7230
	15	09 64 222 7230	09 64 212 7230
	25	09 64 322 7230	09 64 312 7230
	37	09 64 422 7230	09 64 412 7230
Connectors with 3900 pF C-filter	9	09 64 122 7240	09 64 112 7240
	15	09 64 222 7240	09 64 212 7240
	25	09 64 322 7240	09 64 312 7240
	37	09 64 422 7240	09 64 412 7240

D-Sub - F

Number of contacts

9-37

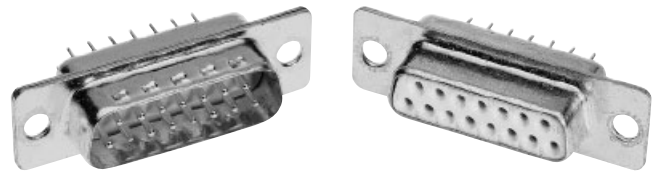

Turned solder pins, straight, through hole

Identification

Drawing

Dimensions in mm

Male connector

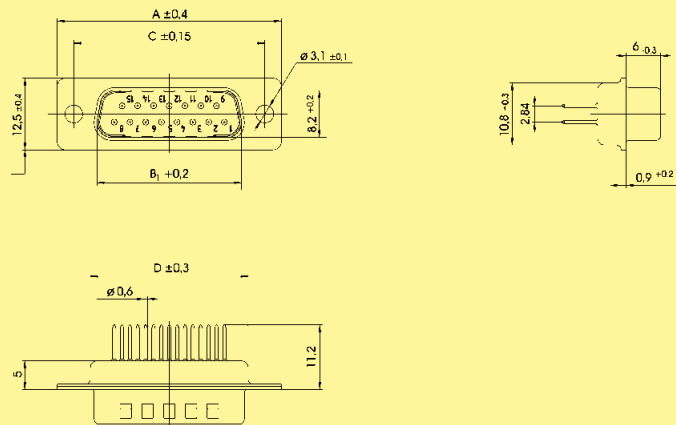

No. of contacts	A	B ₁	B ₂	C	D	E	F	G
9	30.8	16.9	16.4	25.00	19.3	1.37	2.74	12.50
15	39.1	25.2	24.7	33.30	27.5	1.37	2.74	16.65
25	53.0	38.9	38.5	47.04	41.3	1.40	2.77	23.52
37	69.3	55.3	54.9	63.50	57.7	1.40	2.77	31.75

Female connector

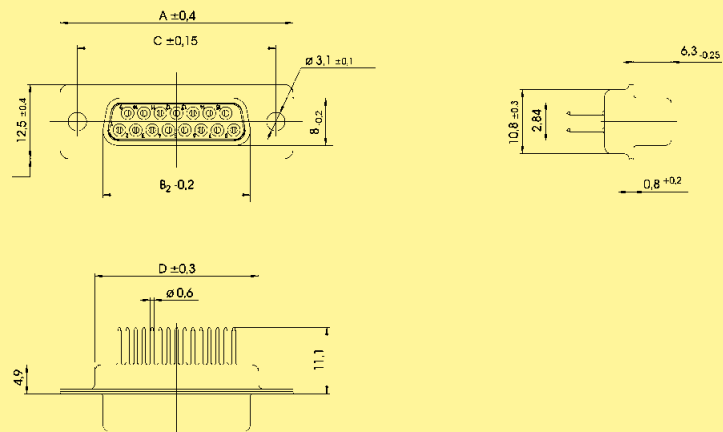

Board drillings

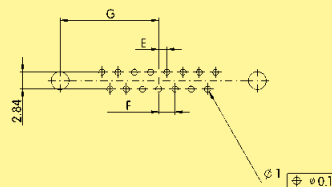

D-Sub



Number of contacts

9-37

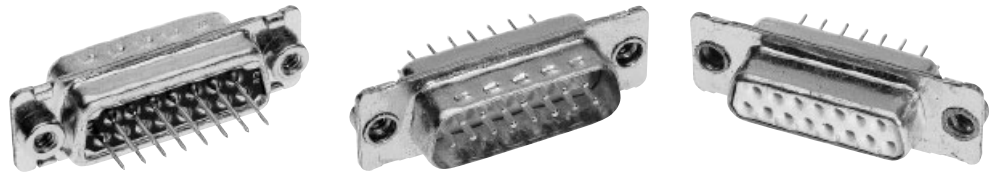

Turned solder pins, straight, clinch nut

Identification	No. of contacts	Part No.	
		male connectors	female connectors
Connectors with 47 pF C-filter	9	09 64 122 721 .	09 64 112 721 .
	15	09 64 222 721 .	09 64 212 721 .
	25	09 64 322 721 .	09 64 312 721 .
	37	09 64 422 721 .	09 64 412 721 .
Connectors with 470 pF C-filter	9	09 64 122 722 .	09 64 112 722 .
	15	09 64 222 722 .	09 64 212 722 .
	25	09 64 322 722 .	09 64 312 722 .
	37	09 64 422 722 .	09 64 412 722 .
Connectors with 1000 pF C-filter	9	09 64 122 723 .	09 64 112 723 .
	15	09 64 222 723 .	09 64 212 723 .
	25	09 64 322 723 .	09 64 312 723 .
	37	09 64 422 723 .	09 64 412 723 .
Connectors with 3900 pF C-filter	9	09 64 122 724 .	09 64 112 724 .
	15	09 64 222 724 .	09 64 212 724 .
	25	09 64 322 724 .	09 64 312 724 .
	37	09 64 422 724 .	09 64 412 724 .
Please insert digit for flange thread	4-40 UNC ▶ 7		
	M3 ▶ 8		

D-Sub - F

Number of contacts

9-37

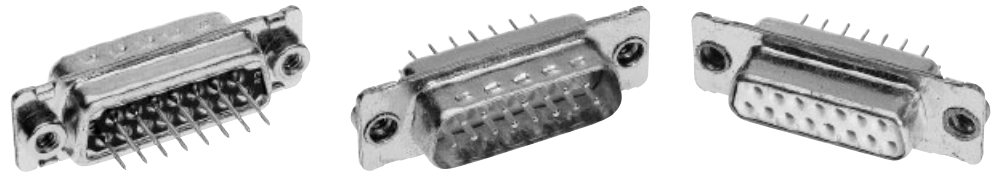

Turned solder pins, straight, clinch nut

Identification

Drawing

Dimensions in mm

Male connector

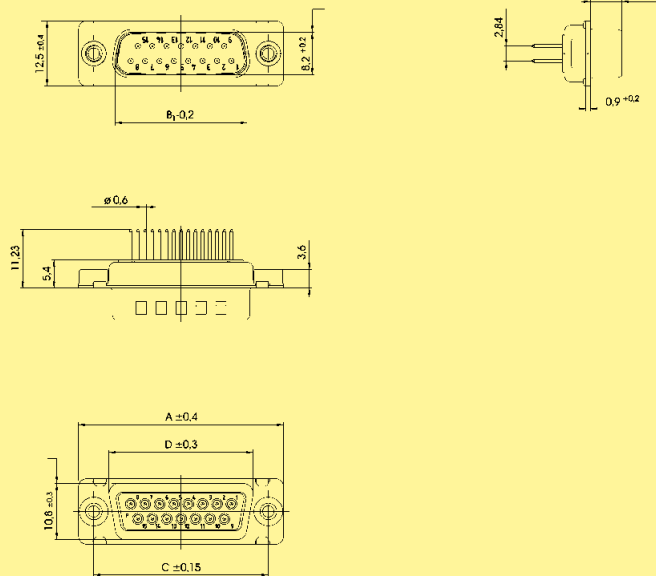

Female connector

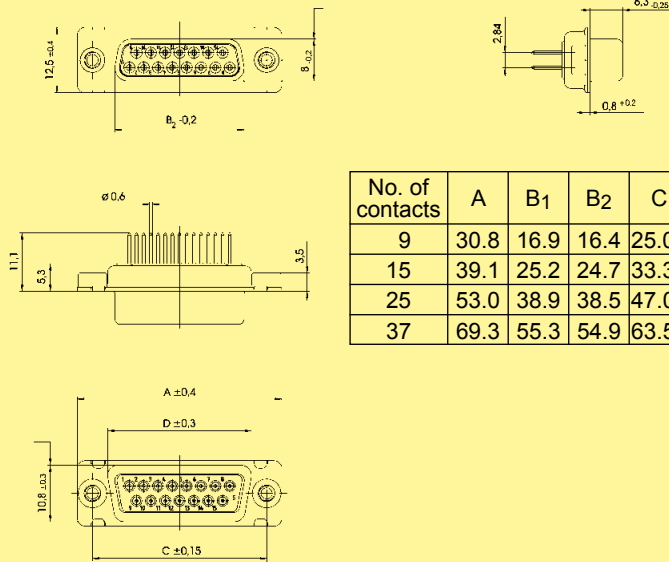

No. of contacts	A	B1	B2	C	D	E	F	G
9	30.8	16.9	16.4	25.00	19.3	1.37	2.74	12.50
15	39.1	25.2	24.7	33.30	27.5	1.37	2.74	16.65
25	53.0	38.9	38.5	47.04	41.3	1.40	2.77	23.52
37	69.3	55.3	54.9	63.50	57.7	1.40	2.77	31.75

Board drillings

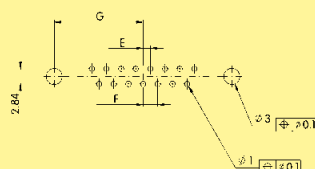

D-Sub



Number of contacts

9-37



Turned solder pins, straight, straight board clips

Identification	No. of contacts	Part No.	
		male connectors	female connectors
Connectors with 47 pF C-filter	9	09 64 122 721 .	09 64 112 721 .
	15	09 64 222 721 .	09 64 212 721 .
	25	09 64 322 721 .	09 64 312 721 .
	37	09 64 422 721 .	09 64 412 721 .
Connectors with 470 pF C-filter	9	09 64 122 722 .	09 64 112 722 .
	15	09 64 222 722 .	09 64 212 722 .
	25	09 64 322 722 .	09 64 312 722 .
	37	09 64 422 722 .	09 64 412 722 .
Connectors with 1000 pF C-filter	9	09 64 122 723 .	09 64 112 723 .
	15	09 64 222 723 .	09 64 212 723 .
	25	09 64 322 723 .	09 64 312 723 .
	37	09 64 422 723 .	09 64 412 723 .
Connectors with 3900 pF C-filter	9	09 64 122 724 .	09 64 112 724 .
	15	09 64 222 724 .	09 64 212 724 .
	25	09 64 322 724 .	09 64 312 724 .
	37	09 64 422 724 .	09 64 412 724 .
Please insert digit for flange thread	4-40 UNC ▶	5	
	M3 ▶	6	

D-Sub - F

Number of contacts

9-37



Turned solder pins, straight, straight board clips

Identification

Drawing

Dimensions in mm

Male connector

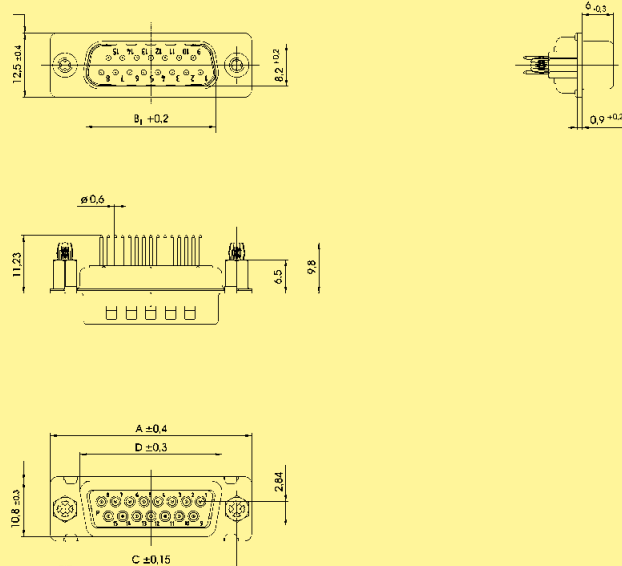

Female connector

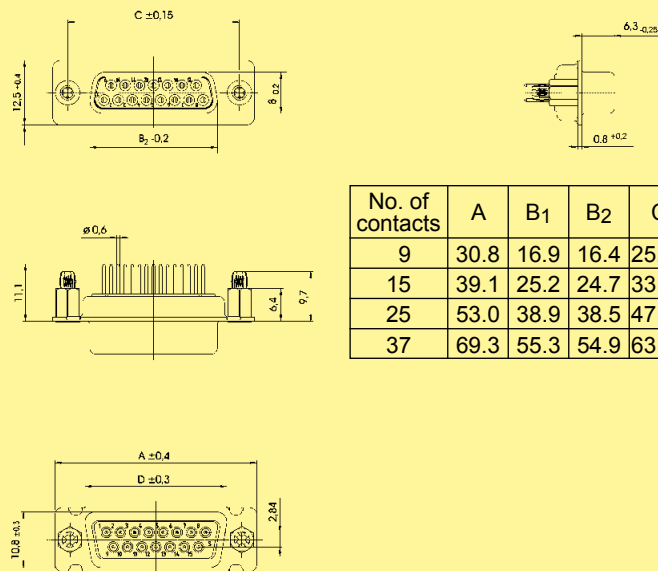

No. of contacts	A	B1	B2	C	D	E	F	G
9	30.8	16.9	16.4	25.00	19.3	1.37	2.74	12.50
15	39.1	25.2	24.7	33.30	27.5	1.37	2.74	16.65
25	53.0	38.9	38.5	47.04	41.3	1.40	2.77	23.52
37	69.3	55.3	54.9	63.50	57.7	1.40	2.77	31.75

Board drillings

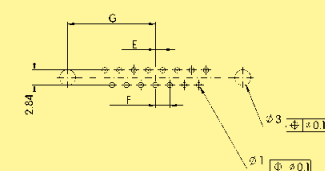

Number of contacts

9-37

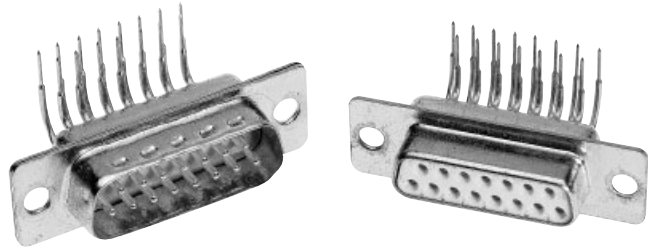

Turned solder pins, right angled, through hole

Identification	No. of contacts	Part No.	
		male connectors	female connectors
Connectors with 47 pF C-filter	9	09 64 124 7210	09 64 114 7210
	15	09 64 224 7210	09 64 214 7210
	25	09 64 324 7210	09 64 314 7210
	37	09 64 424 7210	09 64 414 7210
Connectors with 470 pF C-filter	9	09 64 124 7220	09 64 114 7220
	15	09 64 224 7220	09 64 214 7220
	25	09 64 324 7220	09 64 314 7220
	37	09 64 424 7220	09 64 414 7220
Connectors with 1000 pF C-filter	9	09 64 124 7230	09 64 114 7230
	15	09 64 224 7230	09 64 214 7230
	25	09 64 324 7230	09 64 314 7230
	37	09 64 424 7230	09 64 414 7230
Connectors with 3900 pF C-filter	9	09 64 124 7240	09 64 114 7240
	15	09 64 224 7240	09 64 214 7240
	25	09 64 324 7240	09 64 314 7240
	37	09 64 424 7240	09 64 414 7240

D-Sub - F

Number of contacts

9-37

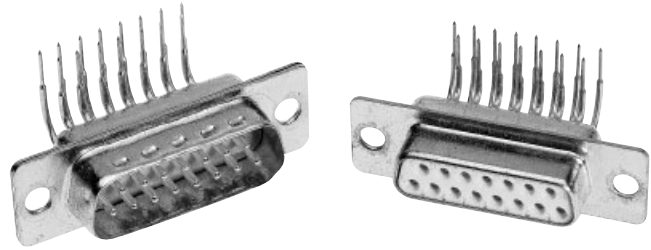

Turned solder pins, right angled, through hole

Identification

Drawing

Dimensions in mm

Male connector

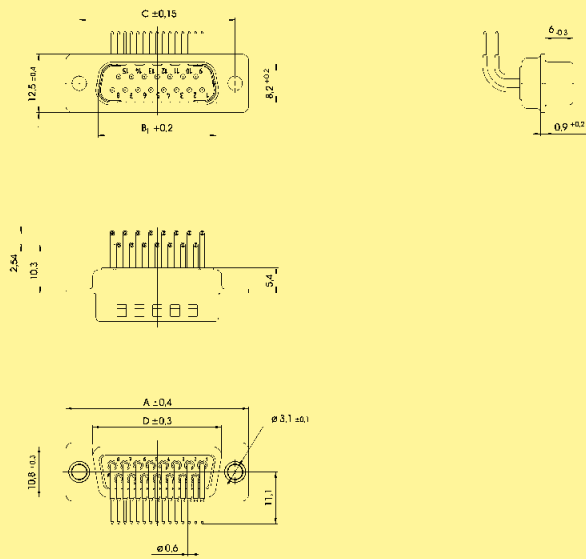

Female connector

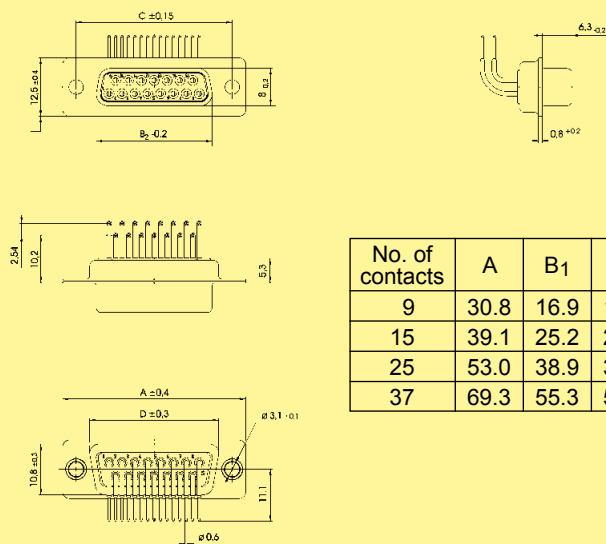

No. of contacts	A	B ₁	B ₂	C	D	E	F
9	30.8	16.9	16.4	25.00	19.3	1.37	2.74
15	39.1	25.2	24.7	33.30	27.5	1.37	2.74
25	53.0	38.9	38.5	47.04	41.3	1.40	2.77
37	69.3	55.3	54.9	63.50	57.7	1.40	2.77

Board drillings

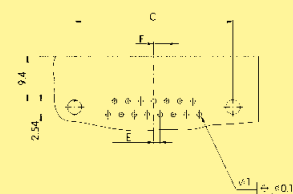

Number of contacts

9-37

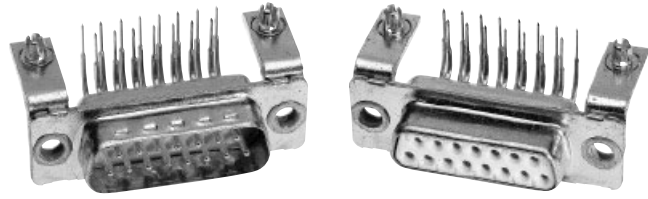

Turned solder pins, right angled, bracket, board lock and through hole

Identification	No. of contacts	Part No.	
		male connectors	female connectors
Connectors with 47 pF C-filter	9	09 64 124 7211	09 64 114 7211
	15	09 64 224 7211	09 64 214 7211
	25	09 64 324 7211	09 64 314 7211
	37	09 64 424 7211	09 64 414 7211
Connectors with 470 pF C-filter	9	09 64 124 7221	09 64 114 7221
	15	09 64 224 7221	09 64 214 7221
	25	09 64 324 7221	09 64 314 7221
	37	09 64 424 7221	09 64 414 7221
Connectors with 1000 pF C-filter	9	09 64 124 7231	09 64 114 7231
	15	09 64 224 7231	09 64 214 7231
	25	09 64 324 7231	09 64 314 7231
	37	09 64 424 7231	09 64 414 7231
Connectors with 3900 pF C-filter	9	09 64 124 7241	09 64 114 7241
	15	09 64 224 7241	09 64 214 7241
	25	09 64 324 7241	09 64 314 7241
	37	09 64 424 7241	09 64 414 7241

D-Sub - F

Number of contacts

9-37



Turned solder pins, right angled, bracket, board lock and through hole

Identification

Drawing

Dimensions in mm

Male connector

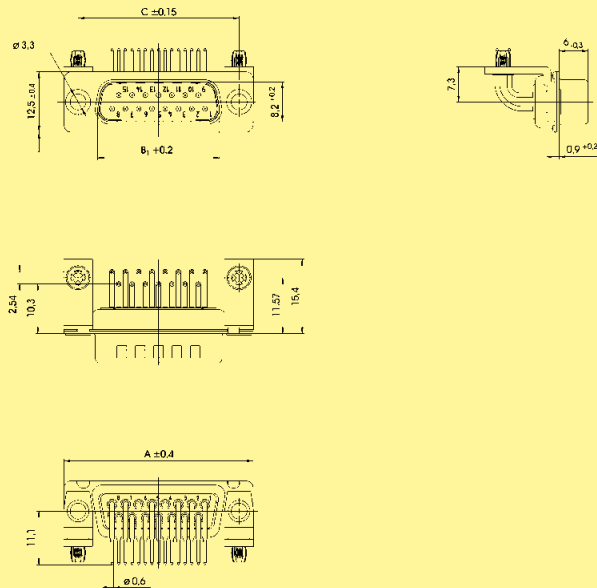

Female connector

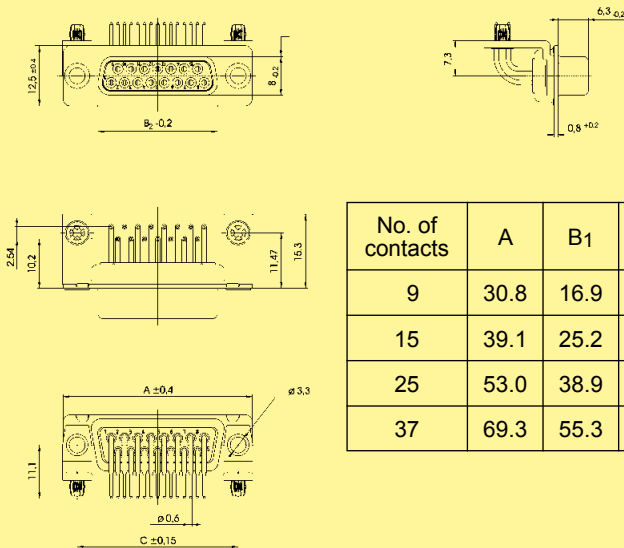

No. of contacts	A	B1	B2	C	E	F
9	30.8	16.9	16.4	25.00	1.37	2.74
15	39.1	25.2	24.7	33.30	1.37	2.74
25	53.0	38.9	38.5	47.04	1.40	2.77
37	69.3	55.3	54.9	63.50	1.40	2.77

Board drillings

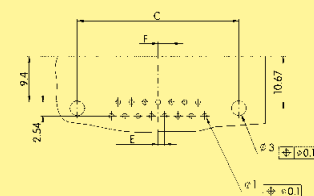

D-Sub



Number of contacts

9-37

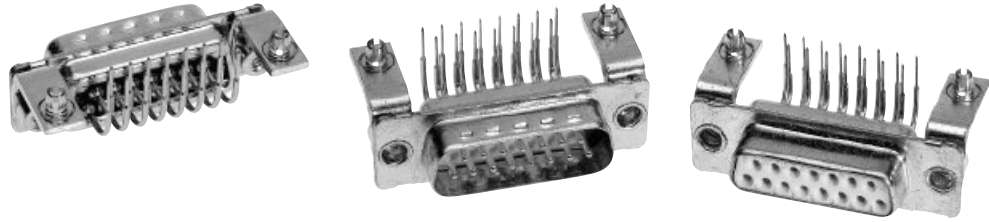

Turned solder pins, right angled, bracket, board lock and clinch nut

Identification	No. of contacts	Part No.	
		male connectors	female connectors
Connectors with 47 pF C-filter	9	09 64 124 721 .	09 64 114 721 .
	15	09 64 224 721 .	09 64 214 721 .
	25	09 64 324 721 .	09 64 314 721 .
	37	09 64 424 721 .	09 64 414 721 .
Connectors with 470 pF C-filter	9	09 64 124 722 .	09 64 114 722 .
	15	09 64 224 722 .	09 64 214 722 .
	25	09 64 324 722 .	09 64 314 722 .
	37	09 64 424 722 .	09 64 414 722 .
Connectors with 1000 pF C-filter	9	09 64 124 723 .	09 64 114 723 .
	15	09 64 224 723 .	09 64 214 723 .
	25	09 64 324 723 .	09 64 314 723 .
	37	09 64 424 723 .	09 64 414 723 .
Connectors with 3900 pF C-filter	9	09 64 124 724 .	09 64 114 724 .
	15	09 64 224 724 .	09 64 214 724 .
	25	09 64 324 724 .	09 64 314 724 .
	37	09 64 424 724 .	09 64 414 724 .
Please insert digit for flange thread	4-40 UNC ▶	2	
	M3 ▶	3	

D-Sub - F

Number of contacts

9-37

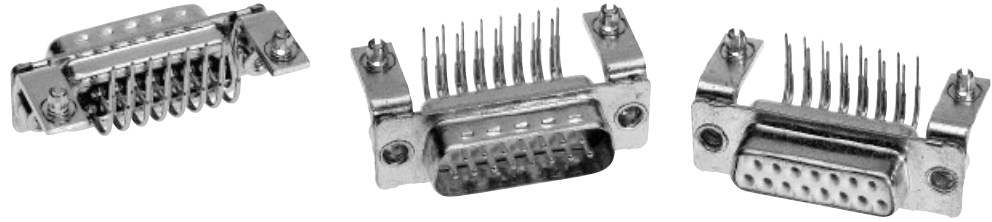

Turned solder pins, right angled, bracket, board lock and clinch nut

Identification

Drawing

Dimensions in mm

Male connector

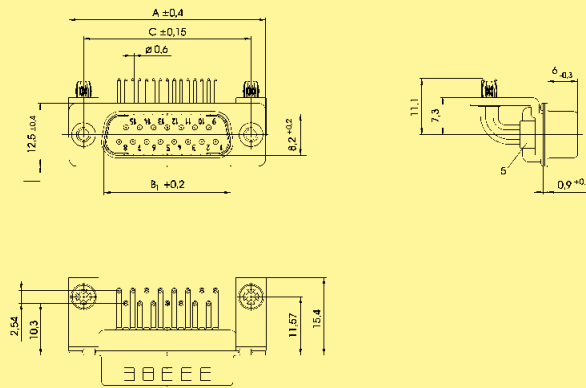

No. of contacts	A	B ₁	B ₂	C	E	F
9	30.8	16.9	16.4	25.00	1.37	2.74
15	39.1	25.2	24.7	33.30	1.37	2.74
25	53.0	38.9	38.5	47.04	1.40	2.77
37	69.3	55.3	54.9	63.50	1.40	2.77

Female connector

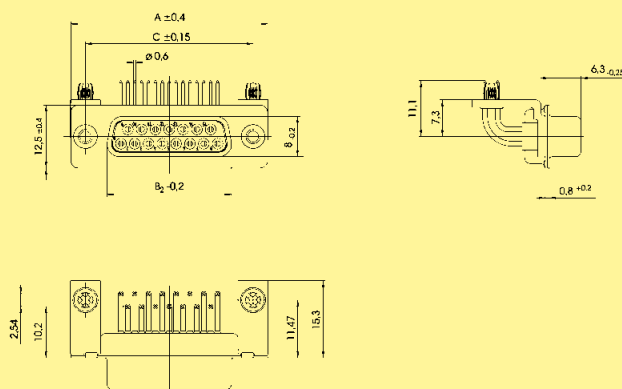

Board drillings

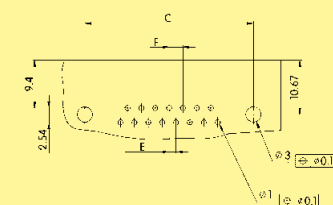

D-Sub



Number of contacts

9-37

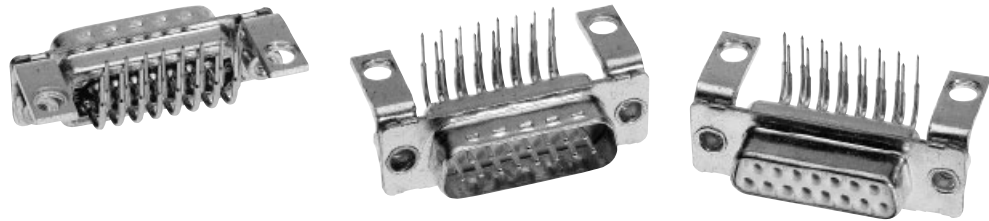

Turned solder pins, right angled, bracket and clinch nut

Identification	No. of contacts	Part No.	
		male connectors	female connectors
Connectors with 47 pF C-filter	9	09 64 124 721 .	09 64 114 721 .
	15	09 64 224 721 .	09 64 214 721 .
	25	09 64 324 721 .	09 64 314 721 .
	37	09 64 424 721 .	09 64 414 721 .
Connectors with 470 pF C-filter	9	09 64 124 722 .	09 64 114 722 .
	15	09 64 224 722 .	09 64 214 722 .
	25	09 64 324 722 .	09 64 314 722 .
	37	09 64 424 722 .	09 64 414 722 .
Connectors with 1000 pF C-filter	9	09 64 124 723 .	09 64 114 723 .
	15	09 64 224 723 .	09 64 214 723 .
	25	09 64 324 723 .	09 64 314 723 .
	37	09 64 424 723 .	09 64 414 723 .
Connectors with 3900 pF C-filter	9	09 64 124 724 .	09 64 114 724 .
	15	09 64 224 724 .	09 64 214 724 .
	25	09 64 324 724 .	09 64 314 724 .
	37	09 64 424 724 .	09 64 414 724 .
Please insert digit for flange thread	4-40 UNC ▶	6	
	M3 ▶	7	

D-Sub - F

Number of contacts

9-37

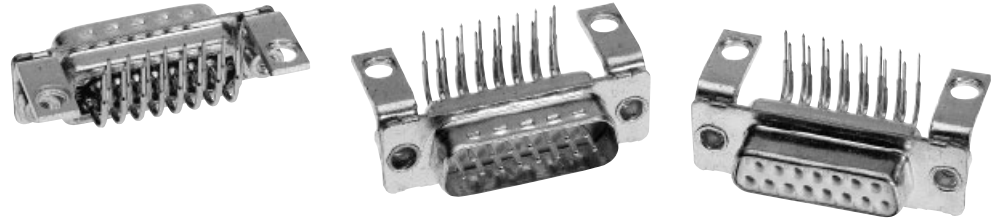

Turned solder pins, right angled, bracket and clinch nut

Identification

Drawing

Dimensions in mm

Male connector

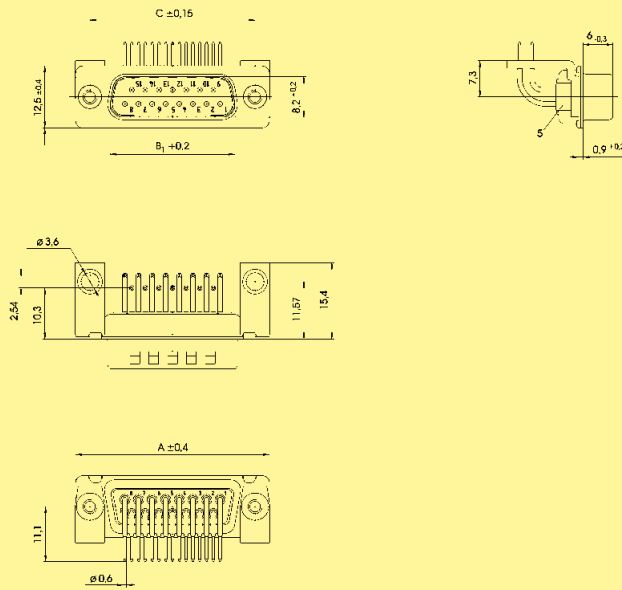

Female connector

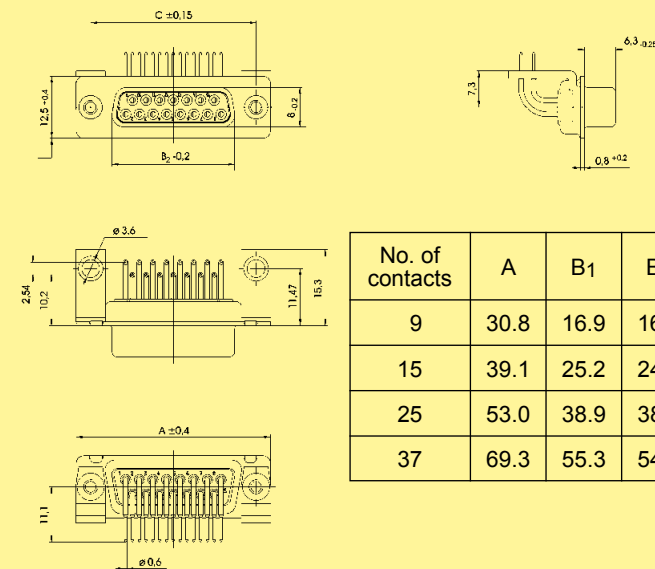

No. of contacts	A	B1	B2	C	E	F
9	30.8	16.9	16.4	25.00	1.37	2.74
15	39.1	25.2	24.7	33.30	1.37	2.74
25	53.0	38.9	38.5	47.04	1.40	2.77
37	69.3	55.3	54.9	63.50	1.40	2.77

Board drillings

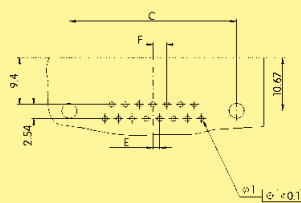

Number of contacts

9-37

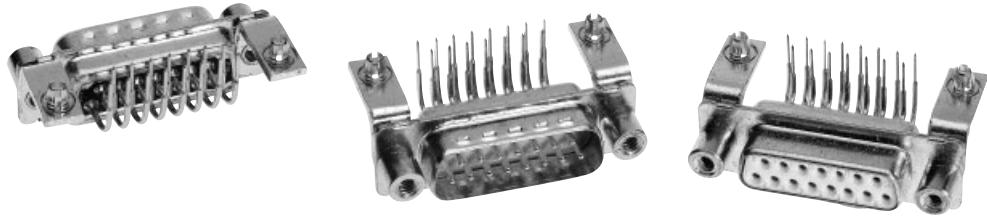

Turned solder pins, right angled, bracket, board lock and female screw

Identification	No. of contacts	Part No.	
		male connectors	female connectors
Connectors with 47 pF C-filter	9	09 64 124 721 .	09 64 114 721 .
	15	09 64 224 721 .	09 64 214 721 .
	25	09 64 324 721 .	09 64 314 721 .
	37	09 64 424 721 .	09 64 414 721 .
Connectors with 470 pF C-filter	9	09 64 124 722 .	09 64 114 722 .
	15	09 64 224 722 .	09 64 214 722 .
	25	09 64 324 722 .	09 64 314 722 .
	37	09 64 424 722 .	09 64 414 722 .
Connectors with 1000 pF C-filter	9	09 64 124 723 .	09 64 114 723 .
	15	09 64 224 723 .	09 64 214 723 .
	25	09 64 324 723 .	09 64 314 723 .
	37	09 64 424 723 .	09 64 414 723 .
Connectors with 3900 pF C-filter	9	09 64 124 724 .	09 64 114 724 .
	15	09 64 224 724 .	09 64 214 724 .
	25	09 64 324 724 .	09 64 314 724 .
	37	09 64 424 724 .	09 64 414 724 .
Please insert digit for flange thread	4-40 UNC ▶	4	
	M3 ▶	5	

D-Sub - F

Number of contacts

9-37

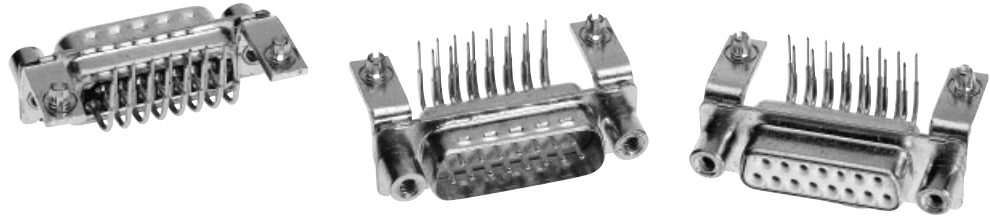

Turned solder pins, right angled, bracket, board lock and female screw

Identification

Drawing

Dimensions in mm

Male connector

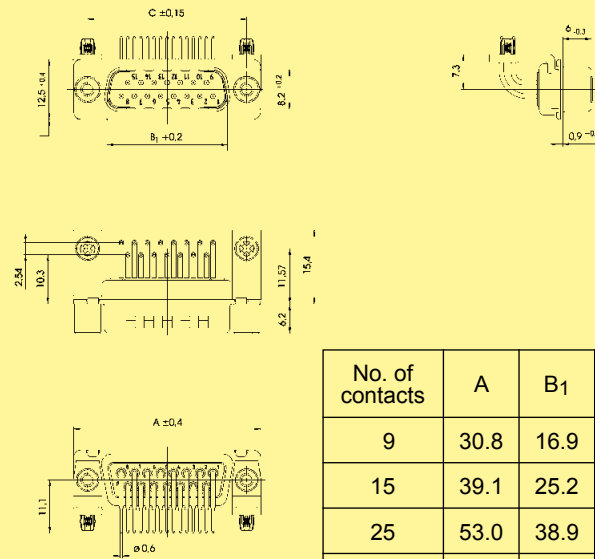

No. of contacts	A	B ₁	B ₂	C	E	F
9	30.8	16.9	16.4	25.00	1.37	2.74
15	39.1	25.2	24.7	33.30	1.37	2.74
25	53.0	38.9	38.5	47.04	1.40	2.77
37	69.3	55.3	54.9	63.50	1.40	2.77

Female connector

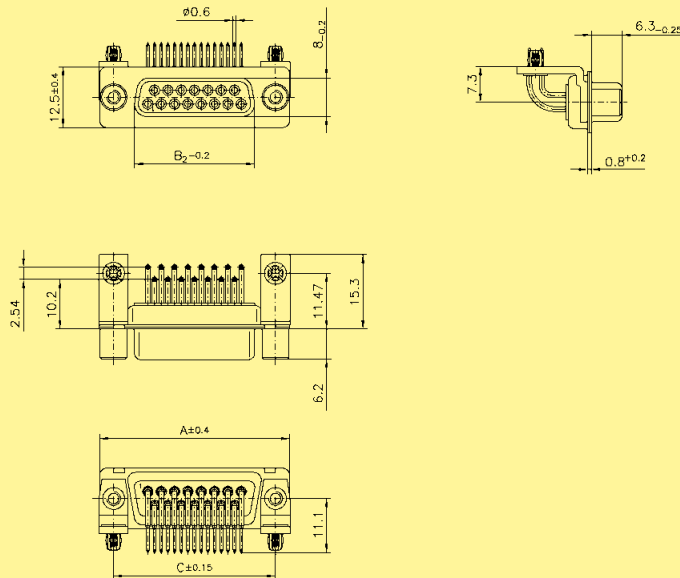

Board drillings

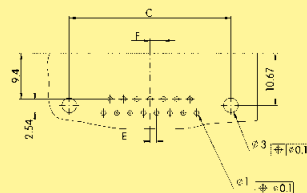

Number of contacts

9-37



Turned solder pins, right angled, bracket and female screw

Identification	No. of contacts	Part No.	
		male connectors	female connectors
Connectors with 47 pF C-filter	9	09 64 124 721 .	09 64 114 721 .
	15	09 64 224 721 .	09 64 214 721 .
	25	09 64 324 721 .	09 64 314 721 .
	37	09 64 424 721 .	09 64 414 721 .
Connectors with 470 pF C-filter	9	09 64 124 722 .	09 64 114 722 .
	15	09 64 224 722 .	09 64 214 722 .
	25	09 64 324 722 .	09 64 314 722 .
	37	09 64 424 722 .	09 64 414 722 .
Connectors with 1000 pF C-filter	9	09 64 124 723 .	09 64 114 723 .
	15	09 64 224 723 .	09 64 214 723 .
	25	09 64 324 723 .	09 64 314 723 .
	37	09 64 424 723 .	09 64 414 723 .
Connectors with 3900 pF C-filter	9	09 64 124 724 .	09 64 114 724 .
	15	09 64 224 724 .	09 64 214 724 .
	25	09 64 324 724 .	09 64 314 724 .
	37	09 64 424 724 .	09 64 414 724 .
Please insert digit for flange thread	4-40 UNC ▶	8	
	M3 ▶	9	

D-Sub - F

Number of contacts

9-37



Turned solder pins, right angled, bracket and female screw

Identification

Drawing

Dimensions in mm

Male connector

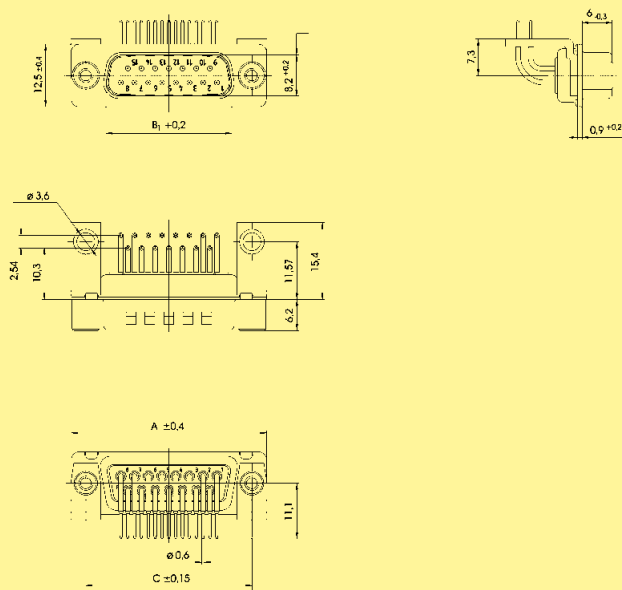

Female connector

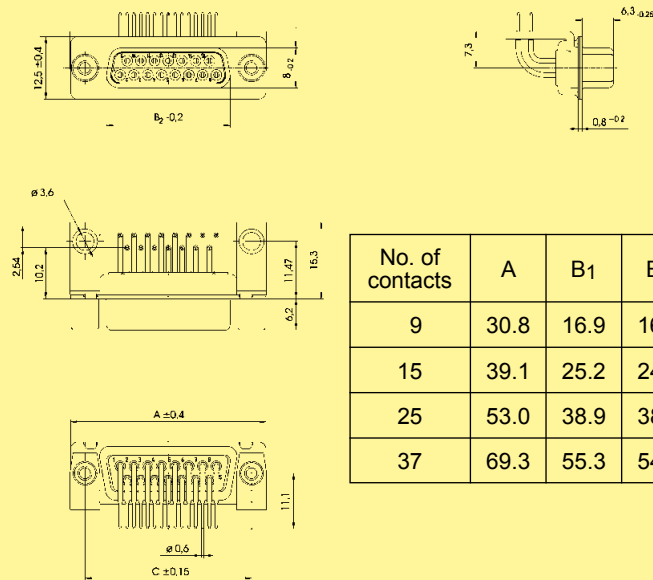

No. of contacts	A	B1	B2	C	E	F
9	30.8	16.9	16.4	25.00	1.37	2.74
15	39.1	25.2	24.7	33.30	1.37	2.74
25	53.0	38.9	38.5	47.04	1.40	2.77
37	69.3	55.3	54.9	63.50	1.40	2.77

Board drillings

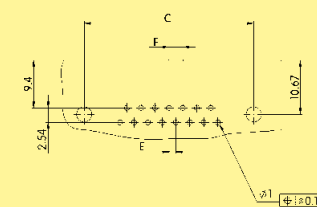

Number of contacts

9-37



Solder buckets, through hole

Identification	No. of contacts	Part No.	
		male connectors	female connectors
Connectors with 47 pF C-filter	9	09 64 121 7210	09 64 111 7210
	15	09 64 221 7210	09 64 211 7210
	25	09 64 321 7210	09 64 311 7210
	37	09 64 421 7210	09 64 411 7210
Connectors with 470 pF C-filter	9	09 64 121 7220	09 64 111 7220
	15	09 64 221 7220	09 64 211 7220
	25	09 64 321 7220	09 64 311 7220
	37	09 64 421 7220	09 64 411 7220
Connectors with 1000 pF C-filter	9	09 64 121 7230	09 64 111 7230
	15	09 64 221 7230	09 64 211 7230
	25	09 64 321 7230	09 64 311 7230
	37	09 64 421 7230	09 64 411 7230
Connectors with 3900 pF C-filter	9	09 64 121 7240	09 64 111 7240
	15	09 64 221 7240	09 64 211 7240
	25	09 64 321 7240	09 64 311 7240
	37	09 64 421 7240	09 64 411 7240

D-Sub - F

Number of contacts

9-37



Solder buckets, through hole

Identification

Drawing

Dimensions in mm

Male connector

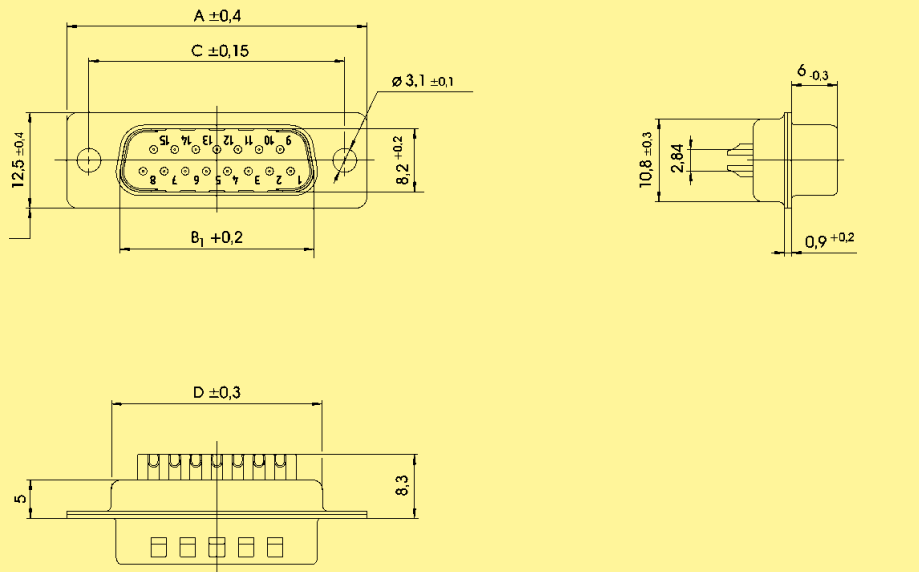

No. of contacts	A	B ₁	B ₂	C	D
9	30.8	16.9	16.4	25.00	19.3
15	39.1	25.2	24.7	33.30	27.5
25	53.0	38.9	38.5	47.04	41.3
37	69.3	55.3	54.9	63.50	57.7

Female connector

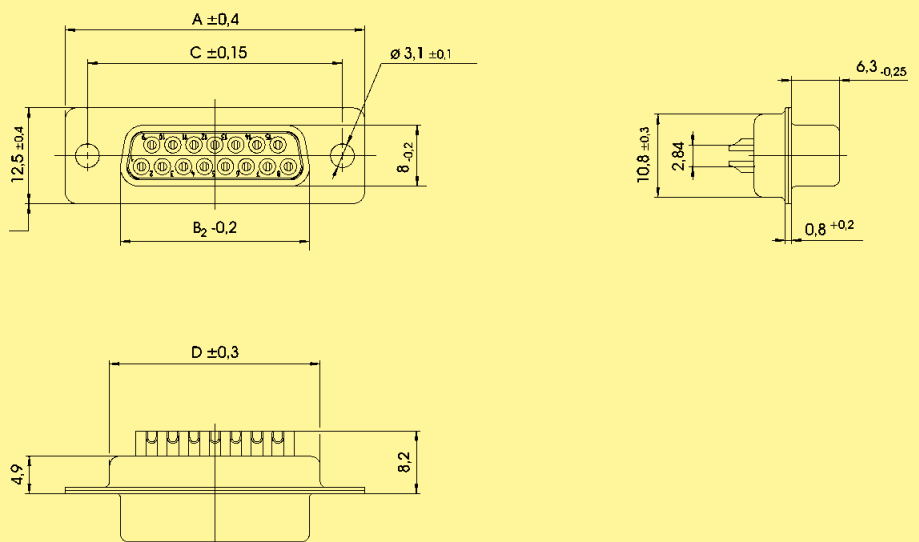

D-Sub - F

D-Sub



Number of contacts

9-37



Solder buckets, clinch nut

Identification	No. of contacts	Part No.	
		male connectors	female connectors
Connectors with 47 pF C-filter	9	09 64 121 721 .	09 64 111 721 .
	15	09 64 221 721 .	09 64 211 721 .
	25	09 64 321 721 .	09 64 311 721 .
	37	09 64 421 721 .	09 64 411 721 .
Connectors with 470 pF C-filter	9	09 64 121 722 .	09 64 111 722 .
	15	09 64 221 722 .	09 64 211 722 .
	25	09 64 321 722 .	09 64 311 722 .
	37	09 64 421 722 .	09 64 411 722 .
Connectors with 1000 pF C-filter	9	09 64 121 723 .	09 64 111 723 .
	15	09 64 221 723 .	09 64 211 723 .
	25	09 64 321 723 .	09 64 311 723 .
	37	09 64 421 723 .	09 64 411 723 .
Connectors with 3900 pF C-filter	9	09 64 121 724 .	09 64 111 724 .
	15	09 64 221 724 .	09 64 211 724 .
	25	09 64 321 724 .	09 64 311 724 .
	37	09 64 421 724 .	09 64 411 724 .
Please insert digit for flange thread	4-40 UNC ▶	7	
	M3 ▶	8	

D-Sub - F

Number of contacts

9-37



Solder buckets, clinch nut

Identification

Drawing

Dimensions in mm

Male connector

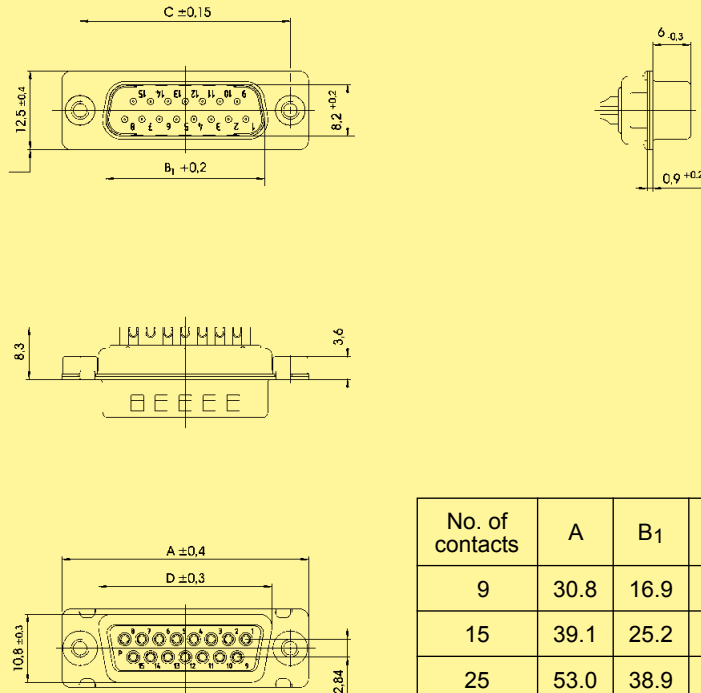

No. of contacts	A	B ₁	B ₂	C	D
9	30.8	16.9	16.4	25.00	19.3
15	39.1	25.2	24.7	33.30	27.5
25	53.0	38.9	38.5	47.04	41.3
37	69.3	55.3	54.9	63.50	57.7

Female connector

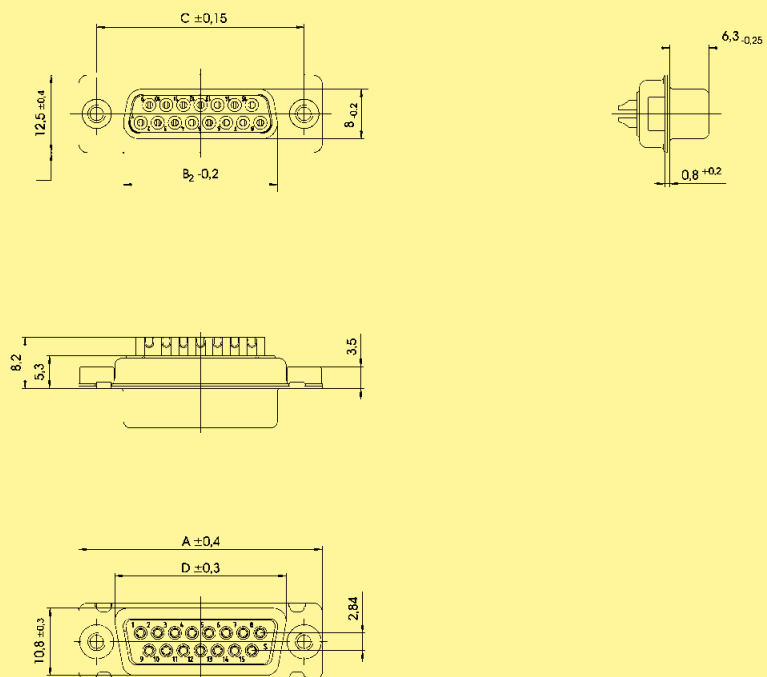

Panel cut outs / panel mountings

Panel cut outs

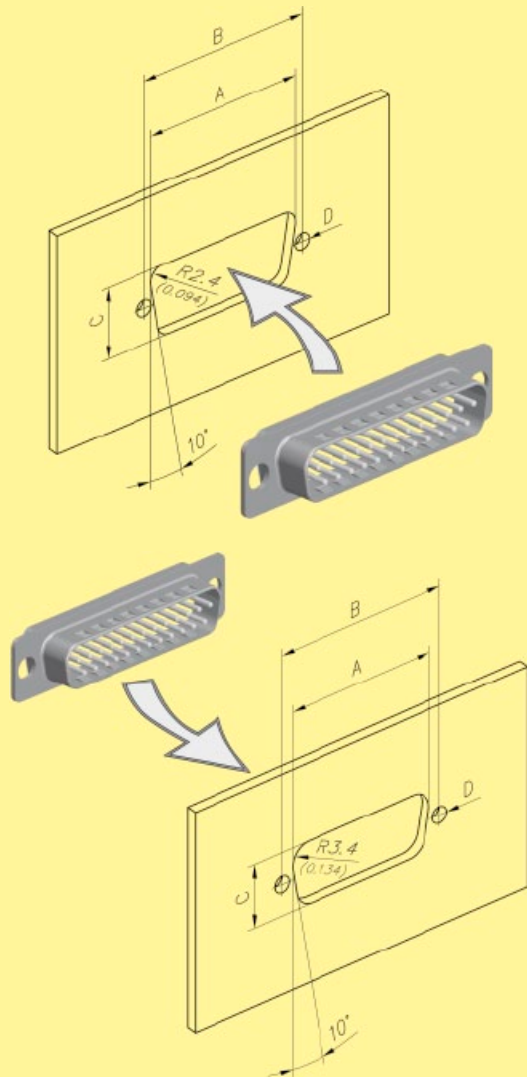

Front mounting

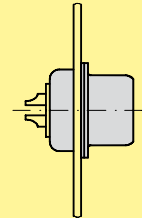

Rear mounting

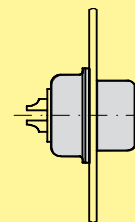

No. of contacts	Mounting assembly	A ± 0.2	B ± 0.2	C ± 0.2
9	Front	22.2	25.0	12.3
	Rear	20.5	25.0	11.4
15	Front	30.5	33.3	12.3
	Rear	28.8	33.3	11.4
25	Front	44.3	47.0	12.3
	Rear	42.5	47.0	11.4
37	Front	60.7	63.5	12.3
	Rear	59.1	63.5	11.4

Panel mountings

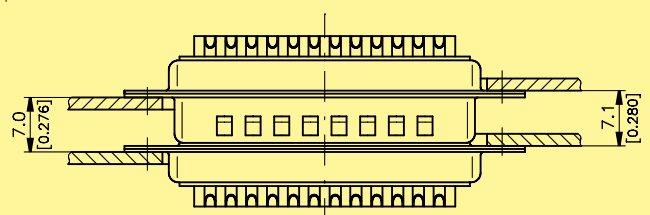
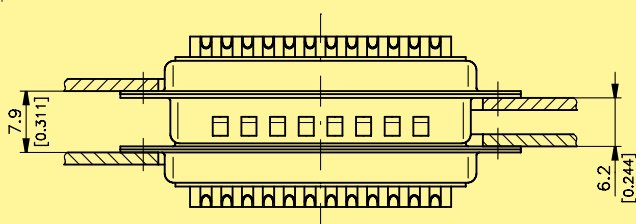

General information

With the innovative EMC platform approach, this enables customers to select their optimum filter requirements, contact per contact. Allowing not only to segregate the filtering per contact but also to mix the type of filter used. This is then cast in a single competitive product (in a standard D-Sub shell).

The biggest advantage of the HARTING technology is that multiple filter assemblies can be configured to create different filter designs: C, Pi, L and T types. Since any value of capacitor can be placed on any contact, a wide range of configurations can be built, it is even possible to have an individual pin unfiltered if necessary.

Furthermore, ***Pi-filters can be supplied in a standard connector size shell.*** In addition, protection against lightening and transient voltage can be included upon request.

In the next few pages, you will find all the necessary information plus a selection guide to help you to choose your appropriate solution.

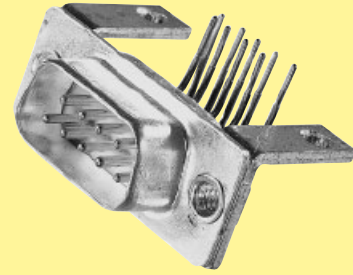

or

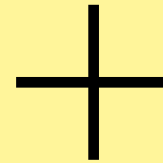
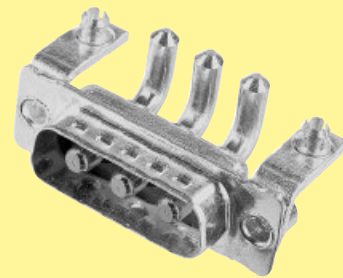

- C-filter
- L-filter
- Pi-filter
- ESD protection
- Lightening protection
- Combination



With any capacitance on any pin in a **standard D-Sub shell.**

General information

Filter possibilities

C-filter:

Non exhaustive list of C-filter values that HARTING can supply (for specials see page 05.36 ff)

C-filter capacitance in pF	Minimum insertion loss								Max. working voltage	Max. dielectric withstanding
	Attenuation [dB] vs frequency [MHz]									
	0.1	1	5	10	50	100	500	1000		
47							30	35	500 V DC	750 V DC
100					1	3	40	35	500 V DC	750 V DC
150					1	6	45	35	500 V DC	750 V DC
180					1	10	40	32	500 V DC	750 V DC
270				1	3	12	35	32	500 V DC	750 V DC
330				1	7	13	35	32	500 V DC	750 V DC
470				1	10	15	35	32	500 V DC	750 V DC
820				2	10	18	30	30	500 V DC	750 V DC
1000			1	3	12	20	34	30	500 V DC	750 V DC
1800			2	6	17	30	35	32	500 V DC	750 V DC
3900		1	6	11	25	35	35	32	500 V DC	750 V DC
4700		1	9	13	30	38	35	32	500 V DC	750 V DC
5600		2	10	14	30	32	32	32	500 V DC	750 V DC
10000		1	10	15	30	32	30	30	200 V DC	500 V DC
33000	1	9	19	29	32	34	39	32	100 V DC	150 V DC
47000	1	11	23	30	32	32	35	32	100 V DC	150 V DC
100000	2	18	32	40	34	34	36	35	25 V DC	40 V DC

Pi filter:

Non exhaustive list of Pi filter values that HARTING can supply (for specials see page 05.36 ff)

Pi filter capacitance in pF	Minimum insertion loss								Max. working voltage	Max. dielectric withstanding
	Attenuation [dB] vs frequency [MHz]									
	0.1	1	5	10	50	100	500	1000		
94						2	35	50	200 V DC	500 V DC
200					1	8	50	40	200 V DC	500 V DC
440				1	8	16	50	40	200 V DC	500 V DC
940				2	12	24	50	40	200 V DC	500 V DC
2000			2	7	17	40	45	40	200 V DC	500 V DC
4400			5	10	28	60	45	40	200 V DC	500 V DC
9400		2	10	15	48	50	45	40	200 V DC	500 V DC
20000		5	14	20	50	60	52	48	100 V DC	250 V DC
94000	2	15	32	50	51	52	48	42	50 V DC	125 V DC
200000	7	21	48	65	55	52	48	42	16 V DC	25 V DC

General information

Other protection possibilities

ESD protection

(Electro Static Discharge protection)

For equipment to comply with:

- IEC-1000-4-2; levels 1 to 4 (Contact discharge test)
- RTCA-160 D; section 25

Typical parasitic capacitance (pF)	Max. clamp voltage (V)	Working voltage (V)
0.5 V _{rms} @ 1 KHz	@ I = 1 A @ 8/20 μS	@ I = 10 μA
1750	7.5	3
1250	13	5
650	22	12
430	33	18
220	48	26
200	51	30

EMP protection

(Electro Magnetic Pulse protection)

For equipment to comply with:

- MIL-STD-461 C: requirements CS 06, CS 10, CS 11, RS 05
- IEC-1000-4-4; EFT TESTS
- RTCA-160 D; section 17

Typical parasitic capacitance (pF)	Max. clamp voltage (V)	Working voltage (V)
0.5 V _{rms} @ 1 KHz	@ I = 10 A @ 8/20 μS	@ I = 10 μA
5675	9	3
3620	15	5
1500	26	14
820	34	18
275	50	26

Lightening protection

For equipment to comply with:

- IEC-1000-4-5; levels 1 and 2 (1.2 μ / 50 μS)
- RTCA-160 D; section 22 (pin injection, level 1)

Typical parasitic capacitance (pF)	Max. clamp voltage (V)	Working voltage (V)
0.5 V _{rms} @ 1 KHz	@ I = 30 A @ 8/20 μS	@ I = 10 μA
5500	12	3
3175	18	5
2000	21	9
1680	30	14
900	38	18
720	60	26
600	63	30

HARTING customer request form

Our innovative technology offers all the possibilities you may need.

For customer solutions, please contact your local HARTING representative.

Here is a summary of the information we need to develop a customer solution:

Connector

Standard D-Sub

Gender Male Female

No. of contacts 9 15 25 37 50

Termination Solder bucket Straight pcb

R/A Eur, 2.54 mm R/A US, 2.84 mm

Mixed D-Sub

Gender Male Female

Contact arrangement 3W3 3W3C Other _____

Power contact rating 10 A 20 A 30 A 40 A

Termination Solder bucket Straight pcb

R/A pcb (please specify the board drillings)

Flange thread and board locking options

Right angled version

- Through hole
- Clinch nut 4-40 UNC
- Clinch nut M3
- Bracket
- Board lock
- Female screw lock 4-40 UNC
- Female screw lock M3

Straight version

- Through hole
- Clinch nut 4-40 UNC
- Clinch nut M3
- Spacer 4-40 UNC
- Spacer M3
- Female screw lock 4-40 UNC
- Spacer 4-40 UNC + board lock
- Spacer M3 + board lock
- Spacer + board lock and female screw lock
 - M3
 - 4-40 UNC

HARTING customer request from

Filter

What working voltage is used? _____

What is the maximum dielectric withstanding voltage needed? _____

Type of filter _____ (C-filter, Pi filter, L filter ...)

Capacitance _____

Are there other protections needed? No
 Yes

ESD Transient
 EMP Lightening

If a pin-to-pin selection has to be done, please state the details

Pin 1: ?, Pin 2: ?, ...

Name: _____

Drawing: no yes

Company: _____

Samples: no yes, quantity

Address: _____

Volume (pcs./year): _____

Phone: _____











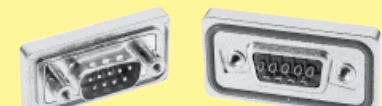

Special requirements: _____

Fax: _____

E-Mail: _____

D-Sub – Waterproof subminiature D IP 67 connectors

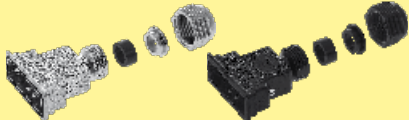
Page

Technical characteristics		06.02
IP 67 versions with turned solder cups		06.04
IP 67 versions with turned solder cups and rear plastic mounting plate		06.06
IP 67 versions with turned solder cups and front plastic mounting plate		06.08
IP 67 versions with turned solder cups and rear metal mounting plate		06.10
IP 67 versions with turned solder cups and front metal mounting plate		06.12
IP 67 versions with straight turned solder pins, rear plastic mounting plate, spacer and board lock		06.14
IP 67 versions with straight turned solder pins, rear metal mounting plate, spacer and board lock		06.16
IP 67 versions with angled turned solder pins, rear plastic mounting plate, bracket and board lock		06.18
IP 67 versions with angled turned solder pins, rear metal mounting plate, bracket and board lock		06.20
Accessories for IP 67 connectors		06.23
IP 67 plastic hoods / IP 67 metallized plastic hoods		06.22 / 06.24
Accessories for IP 67 hoods		06.25

Number of contacts	9, 15, 25, 37, 50 UL recognized
Working current	5 A
Test voltage	1200 V for 1 minute between 2 contacts / contact and shell
Clearance and creepage	≥ 1.0 mm
Contact resistance	
Straight contact	≤ 10 mΩ
Angled contact	≤ 25 mΩ
Angled contact 50 pole	≤ 35 mΩ
Insulation resistance	between contacts ≥ 5000 MΩ
Dielectric strength	50 kV/mm
Temperature range	-25 °C ... +70 °C
Protection	IP 67 (per DIN 40050 / IEC 529)
Termination	
Solder cup	max. AWG 20
Solder pin straight	0.6 mm diameter
Solder pin angled	0.6 mm diameter
Material	
Shell	Brass, tin plated
Insulator and plastic watertight frame	Thermoplastic, glass-fibre filled, UL 94-V0
Metal watertight frame	Nickel plated zinc die cast
Contact material	Machined copper alloy
Contact surface	
Contact zone	S4 = 0.76 μm (30 pinch) Au or PdNi equivalent
Waterproofing element	Silicone
Mechanical	
Mating cycles	≥ 500
Mating force per signal contact	≤ 3.4 N
Unmating force per signal contact	≥ 0.2 N

Contact arrangement View from termination side

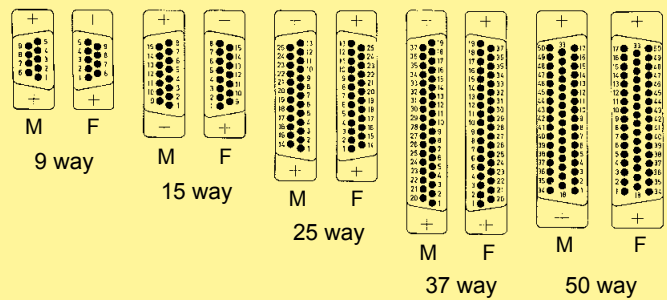

M = Male connector
F = Female connector

Mating conditions as per DIN 41 652

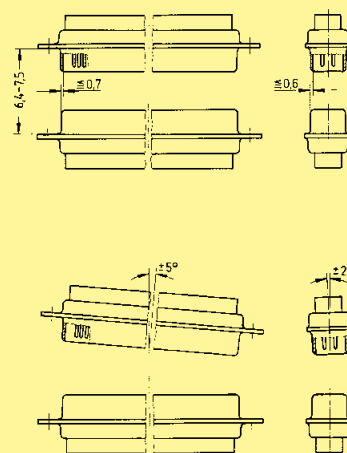

D-Sub - W

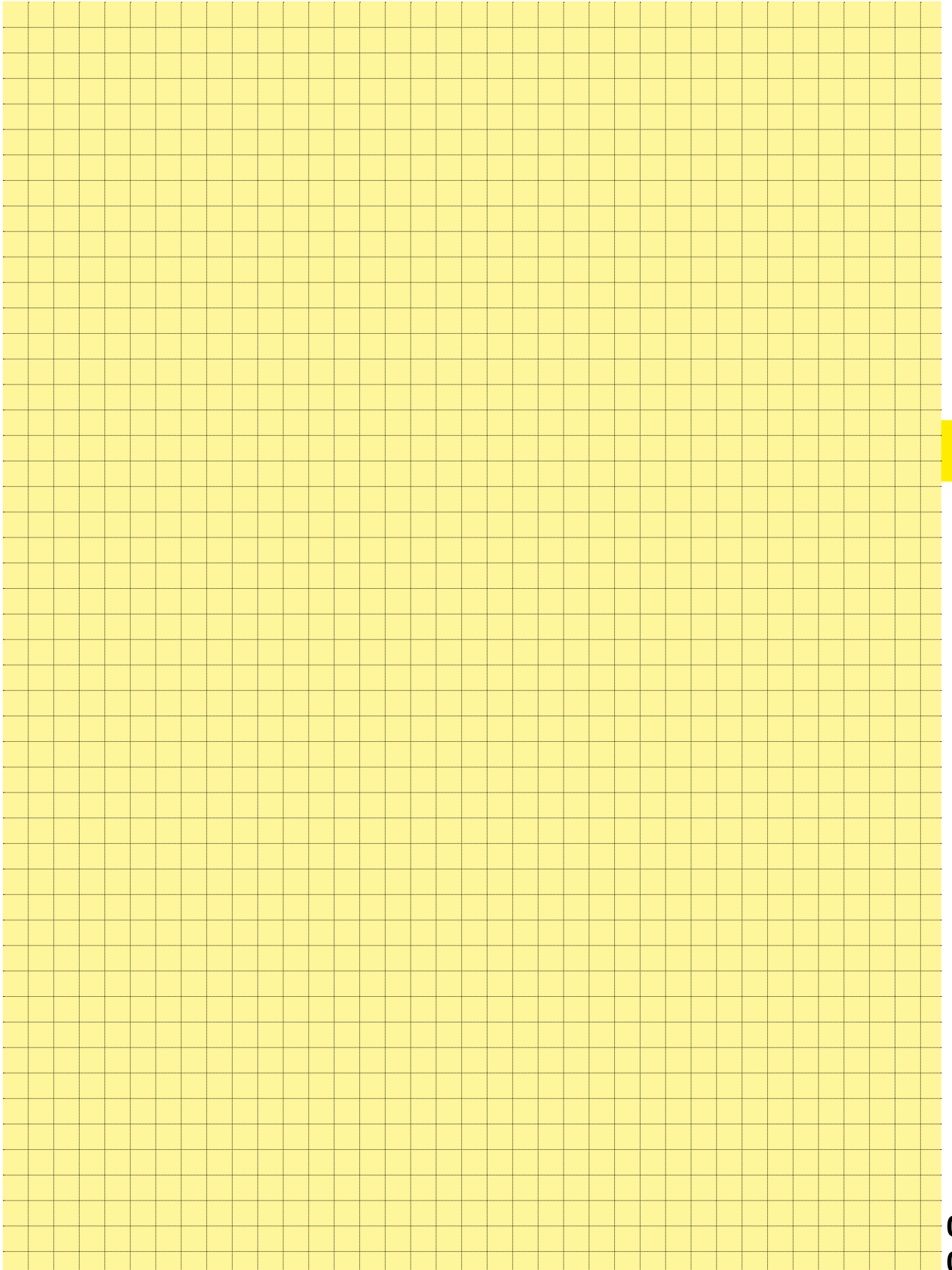

Number of contacts

9-50

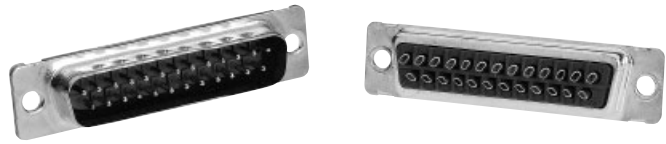

IP 67, turned solder cups

Identification	No. of contacts	Part No.
S4 ¹⁾		
Male connector metal shell with dimples	9 15 25 37 50	09 67 409 5615 09 67 415 5615 09 67 425 5615 09 67 437 5615 09 67 450 5615
Female connector metal shell	9 15 25 37 50	09 67 409 4715 09 67 415 4715 09 67 425 4715 09 67 437 4715 09 67 450 4715

D-Sub - W

¹⁾ S4 = 0.76 µm (30 µinch) Au or PdNi equivalent

Number of contacts

9-50

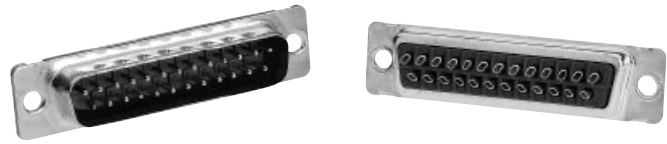

IP 67, turned solder cups

Identification

Drawing

Dimensions in mm

Male connector
9 – 50 contacts

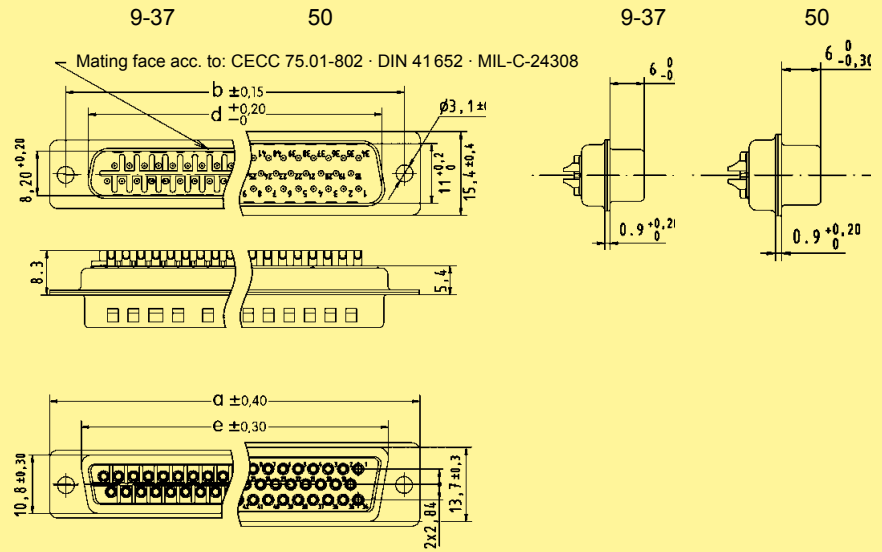

Female connector
9 – 50 contacts

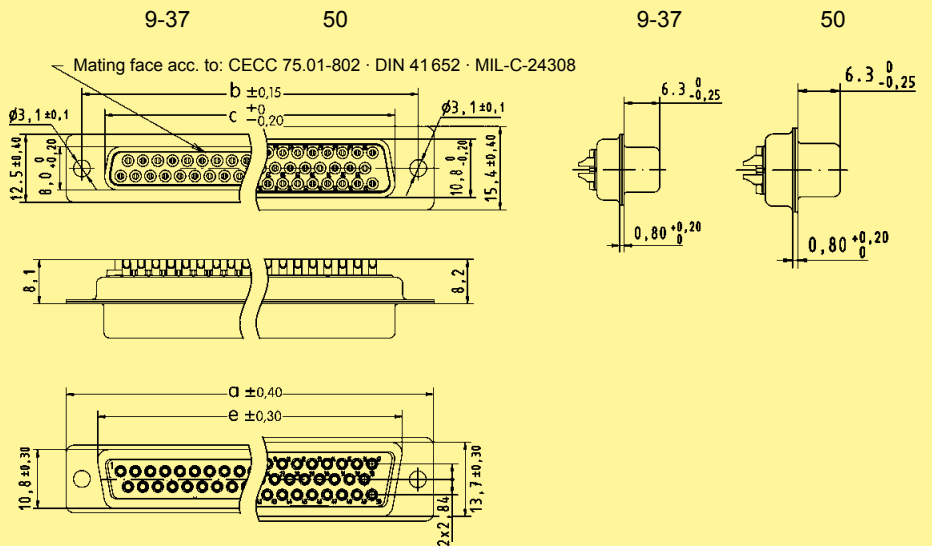

	a	b	c	d	e
9	30.8	25.00	16.4	16.9	19.3
15	39.1	33.30	24.7	25.2	27.5
25	53.0	47.04	38.5	38.9	41.3
37	69.3	63.50	54.9	55.3	57.7
50	66.9	61.10	52.5	52.8	55.3

Number of contacts

9-25



IP 67, turned solder cups, with rear plastic mounting plate

Identification	No. of contacts	Part No.	
		S4 ¹⁾	
Male connector metal shell with dimples	9 15 25	09 67 509 .	615
		09 67 515 .	615
		09 67 525 .	615
Please insert digit for flange thread			
4-40 UNC ▶	7		
M3 ▶	9		
Female connector metal shell	9 15 25	09 67 509 .	715
		09 67 515 .	715
		09 67 525 .	715
Please insert digit for flange thread			
4-40 UNC ▶	6		
M3 ▶	8		

D-Sub - W

¹⁾ S4 = 0.76 µm (30 µinch) Au or PdNi equivalent

Number of contacts

9-25



IP 67, turned solder cups, with rear plastic mounting plate

Identification

Drawing

Dimensions in mm

Male connector

9 – 25 contacts

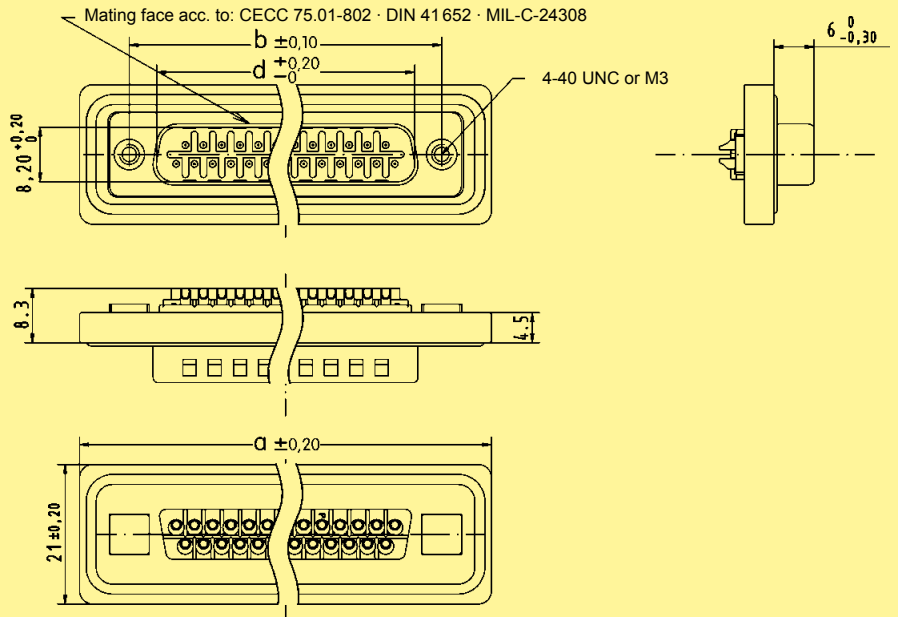

Female connector

9 – 25 contacts

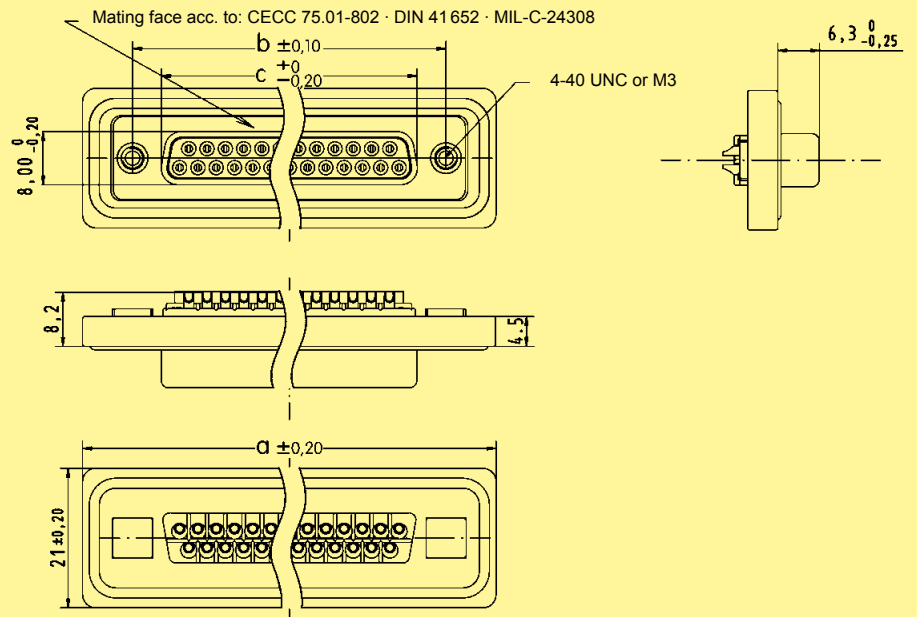

	a	b	c	d
9	40.0	25.00	16.4	16.9
15	48.3	33.30	24.7	25.2
25	62.0	47.04	38.5	38.9

Number of contacts

9-25

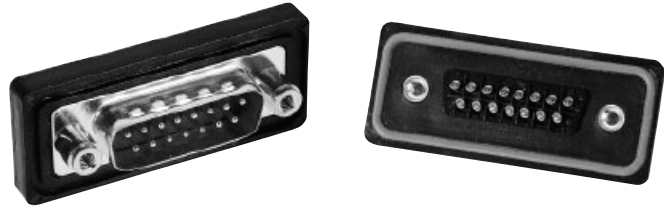

IP 67, turned solder cups, with front plastic mounting plate

Identification	No. of contacts	Part No.	
		S4 ¹⁾	
Male connector metal shell with dimples	9 15 25	09 67 709 .	615
		09 67 715 .	615
		09 67 725 .	615
Please insert digit for flange thread			
4-40 UNC ▶	7		
M3 ▶	9		
Female connector metal shell	9 15 25	09 67 709 .	715
		09 67 715 .	715
		09 67 725 .	715
Please insert digit for flange thread			
4-40 UNC ▶	6		
M3 ▶	8		

D-Sub - W

¹⁾ S4 = 0.76 µm (30 µinch) Au or PdNi equivalent

Number of contacts

9-25

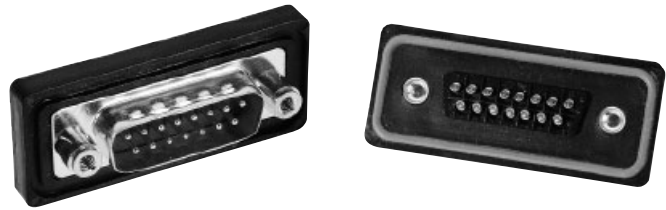

IP 67, turned solder cups, with front plastic mounting plate

Identification

Drawing

Dimensions in mm

Male connector
9 – 25 contacts

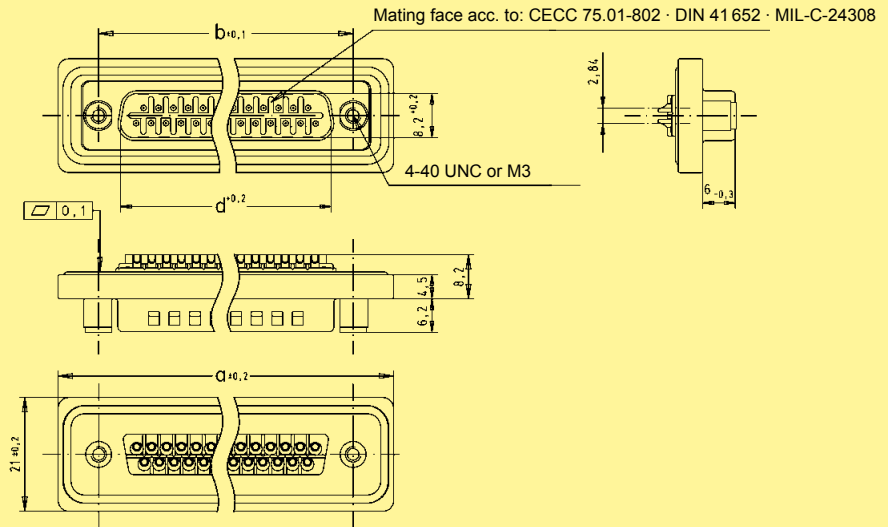

Female connector
9 – 25 contacts

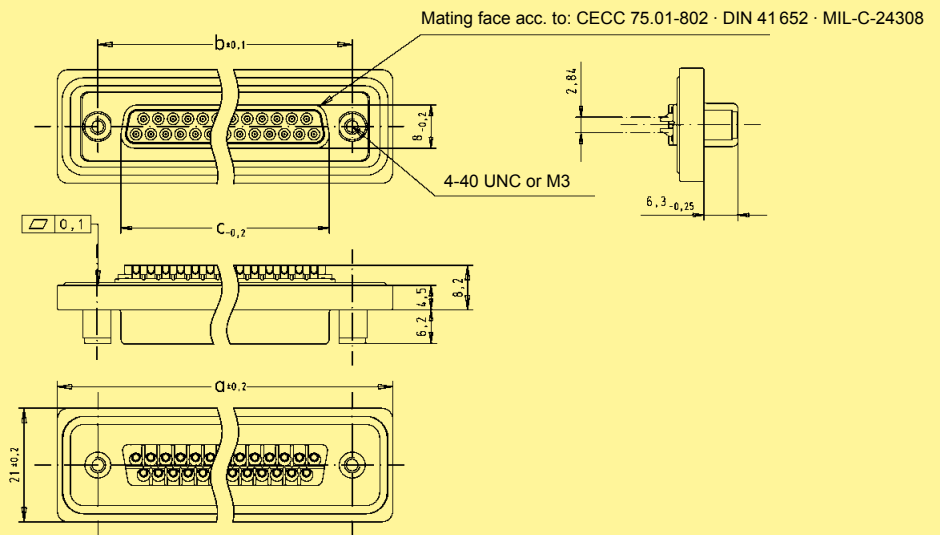

	a	b	c	d
9	40.0	25.00	16.4	16.9
15	48.3	33.30	24.7	25.2
25	62.0	47.04	38.5	38.9

Panel cut out
for front/rear mount

Values are taken from the
CECC 75 301-802

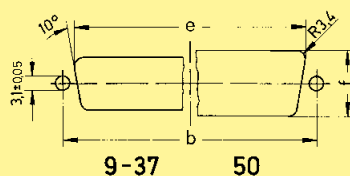

Front mount

	$b_{\pm 0.13}$	$e_{\pm 0.2}$	$f_{\pm 0.2}$
9	25.0	22.2	12.3
15	33.3	30.5	12.3
25	47.0	44.3	12.3

Rear mount

	$b_{\pm 0.13}$	$e_{\pm 0.2}$	$f_{\pm 0.2}$
9	25.0	20.5	11.4
15	33.3	28.8	11.4
25	47.0	42.5	11.4

Number of contacts

9-50



IP 67, turned solder cups, with rear metal mounting plate

Identification	No. of contacts	Part No.	
		S4 ¹⁾	
Male connector metal shell with dimples			
	9	09 67 609	. 615
	15	09 67 615	. 615
	25	09 67 625	. 615
	37	09 67 637	. 615
	50	09 67 650	. 615
Please insert digit for flange thread			
4-40 UNC ▶	7		
M3 ▶	9		
Female connector metal shell			
	9	09 67 609	. 715
	15	09 67 615	. 715
	25	09 67 625	. 715
	37	09 67 637	. 715
	50	09 67 650	. 715
Please insert digit for flange thread			
4-40 UNC ▶	6		
M3 ▶	8		

D-Sub - W

¹⁾ S4 = 0.76 µm (30 µinch) Au or PdNi equivalent

Number of contacts

9-50



IP 67, turned solder cups, with rear metal mounting plate

Identification

Drawing

Dimensions in mm

Male connector
9 – 50 contacts

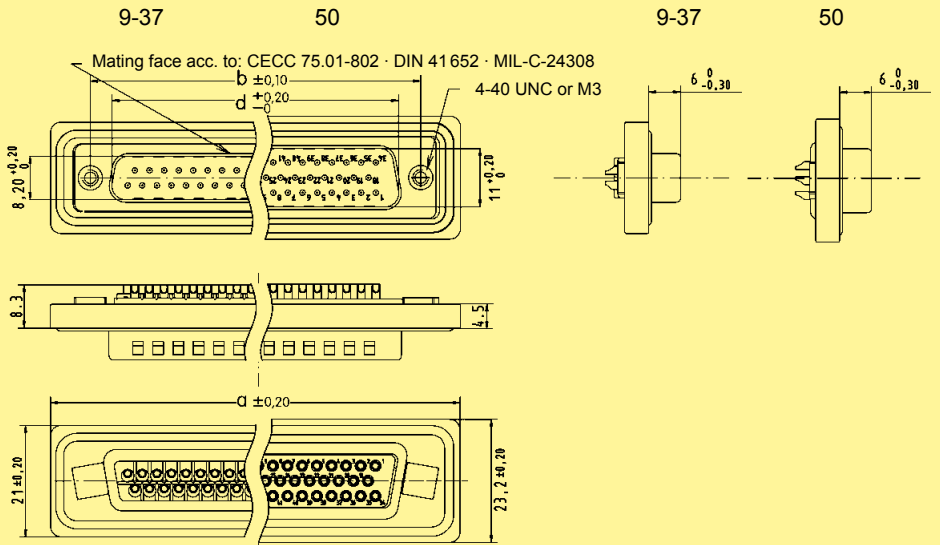

Female connector
9 – 50 contacts

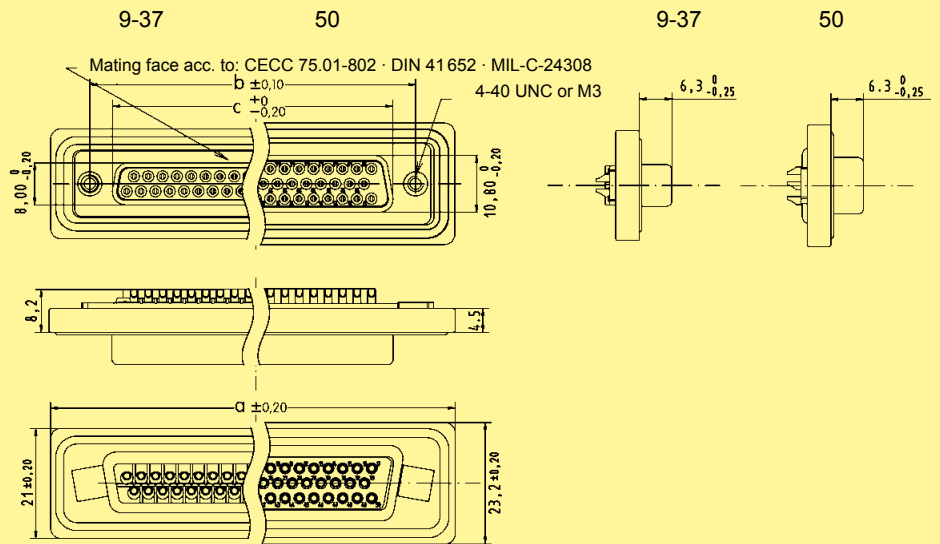

	a	b	c	d
9	40,0	25,00	16,4	16,9
15	48,3	33,30	24,7	25,2
25	62,0	47,04	38,5	38,9
37	78,5	63,50	54,9	55,3
50	76,1	61,10	52,5	52,8

Number of contacts

9-50

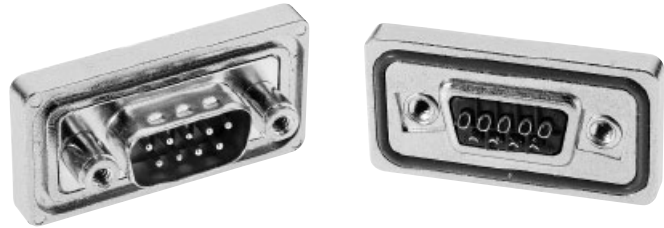

IP 67, turned solder cups, with front metal mounting plate

Identification	No. of contacts	Part No.	
		S4 ¹⁾	
Male connector metal shell with dimples			
	9	09 67 809	615
	15	09 67 815	615
	25	09 67 825	615
	37	09 67 837	615
	50	09 67 850	615
Please insert digit for flange thread			
4-40 UNC ▶	7		
M3 ▶	9		
Female connector metal shell			
	9	09 67 809	715
	15	09 67 815	715
	25	09 67 825	715
	37	09 67 837	715
	50	09 67 850	715
Please insert digit for flange thread			
4-40 UNC ▶	6		
M3 ▶	8		

D-Sub - W

¹⁾ S4 = 0.76 µm (30 µinch) Au or PdNi equivalent

Number of contacts

9-50

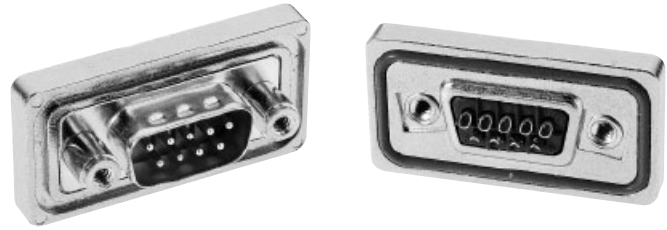

IP 67, turned solder cups, with front metal mounting plate

Identification

Drawing

Dimensions in mm

Male connector
9 – 50 contacts

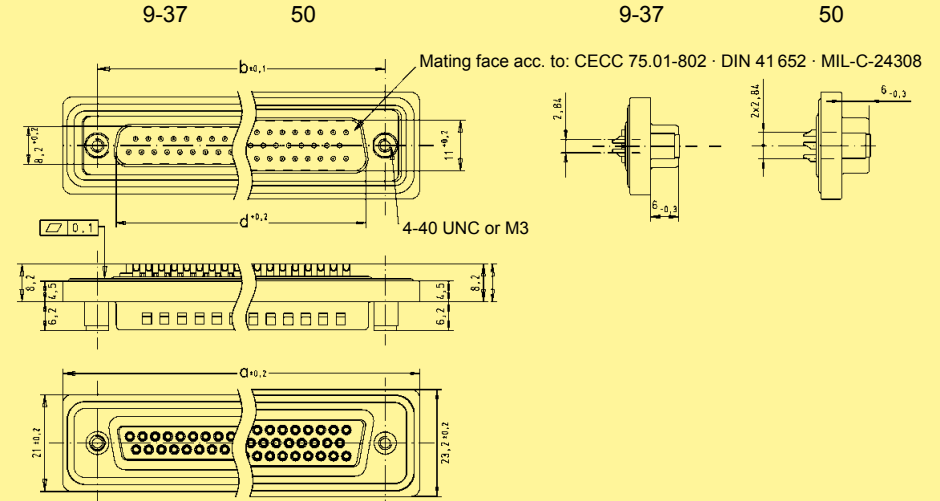

Female connector
9 – 50 contacts

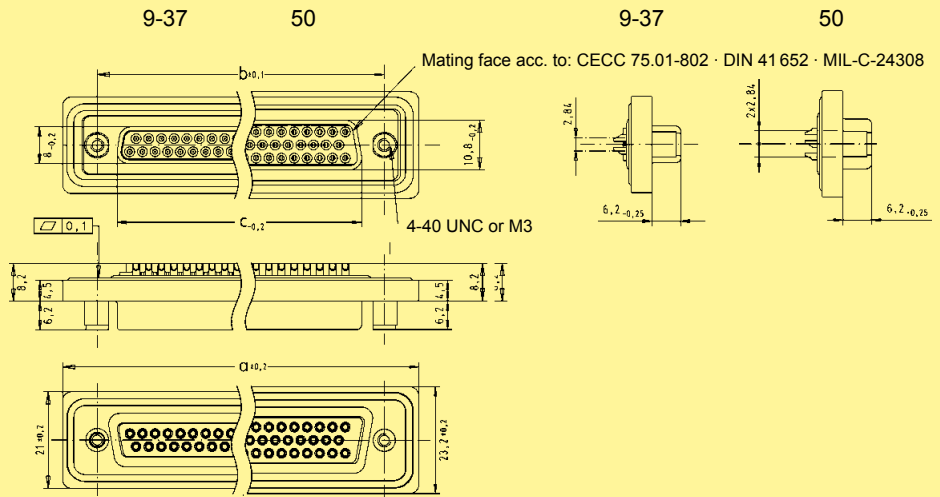

	a	b	c	d
9	40.0	25.00	16.4	16.9
15	48.3	33.30	24.7	25.2
25	62.0	47.04	38.5	38.9
37	78.5	63.50	54.9	55.3
50	76.1	61.10	51.3	52.8

Panel cut out
for front/rear mount

Values are taken from the
CECC 75 301-802

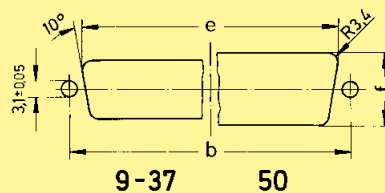

Front mount

	$b_{\pm 0.13}$	$e_{\pm 0.2}$	$f_{\pm 0.2}$
9	25.0	22.2	12.3
15	33.3	30.5	12.3
25	47.0	44.3	12.3
37	63.5	60.7	12.3
50	61.1	58.3	15.1

Rear mount

	$b_{\pm 0.13}$	$e_{\pm 0.2}$	$f_{\pm 0.2}$
9	25.0	20.5	11.4
15	33.3	28.8	11.4
25	47.0	42.5	11.4
37	63.5	59.1	11.4
50	61.1	56.3	14.1

Number of contacts

9-25



IP 67, straight turned solder pins,
with rear plastic mounting plate, spacer and board lock

Identification	No. of contacts	Part No.	
		S4 ¹⁾	
Male connector metal shell with dimples	9 15 25	09 67 509 .	675
		09 67 515 .	675
		09 67 525 .	675
Please insert digit for flange thread			
4-40 UNC ▶	7		
M3 ▶	9		
Female connector metal shell	9 15 25	09 67 509 .	775
		09 67 515 .	775
		09 67 525 .	775
Please insert digit for flange thread			
4-40 UNC ▶	6		
M3 ▶	8		

D-Sub - W

¹⁾ S4 = 0.76 µm (30 µinch) Au or PdNi equivalent

Number of contacts

9-25



IP 67, straight turned solder pins,
with rear plastic mounting plate, spacer and board lock

Identification

Drawing

Dimensions in mm

Male connector
9 – 25 contacts

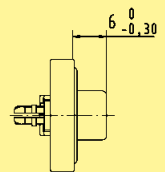
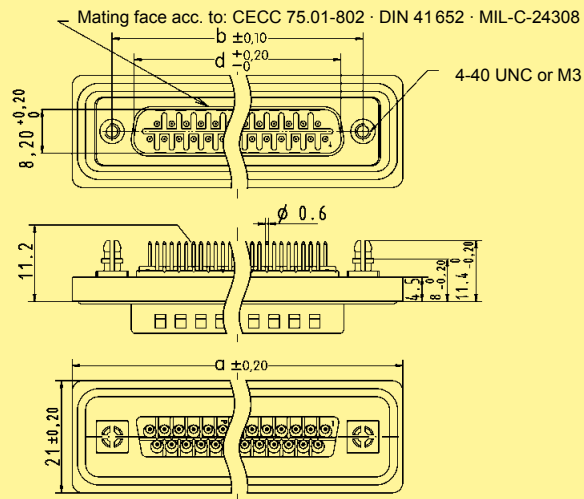

Female connector
9 – 25 contacts

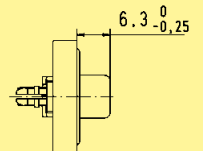
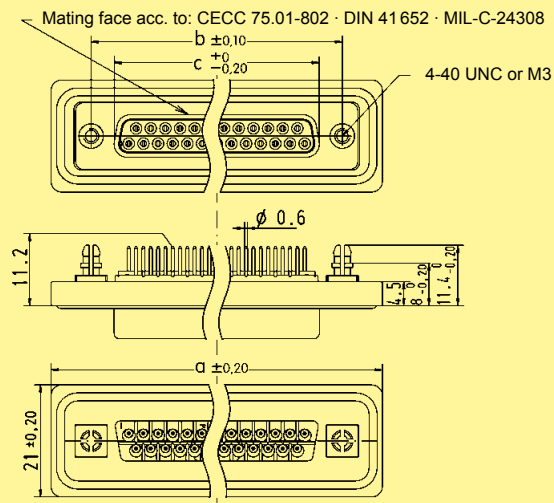

	a	b	c	d	g	h	i
9	40.0	25.00	16.4	16.9	4 x 2.74 = 10.96	3 x 2.74 = 8.22	25.0
15	48.3	33.30	24.7	25.2	7 x 2.74 = 19.18	6 x 2.74 = 16.44	33.3
25	62.0	47.04	38.5	38.9	12 x 2.76 = 33.12	11 x 2.76 = 30.36	47.0

Board drillings

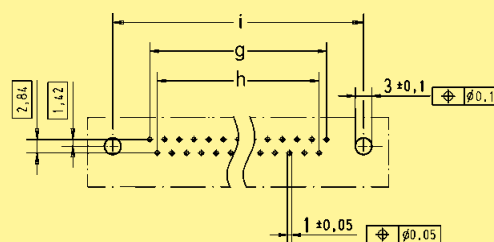

Number of contacts

9-50



IP 67, straight turned solder pins,
with rear metal mounting plate, spacer and board lock

Identification	No. of contacts	Part No.	
		S4 ¹⁾	
Male connector metal shell with dimples			
	9	09 67 609	. 675
	15	09 67 615	. 675
	25	09 67 625	. 675
	37	09 67 637	. 675
	50	09 67 650	. 675
Please insert digit for flange thread			
4-40 UNC ▶	7		
M3 ▶	9		
Female connector metal shell			
	9	09 67 609	. 775
	15	09 67 615	. 775
	25	09 67 625	. 775
	37	09 67 637	. 775
	50	09 67 650	. 775
Please insert digit for flange thread			
4-40 UNC ▶	6		
M3 ▶	8		

D-Sub - W

¹⁾ S4 = 0.76 µm (30 µinch) Au or PdNi equivalent

Number of contacts

9-50

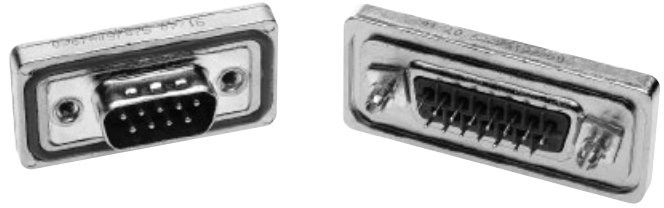

IP 67, straight turned solder pins, with rear metal mounting plate, spacer and board lock

Identification

Drawing

Dimensions in mm

Male connector
9 – 50 contacts

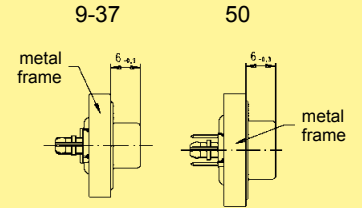
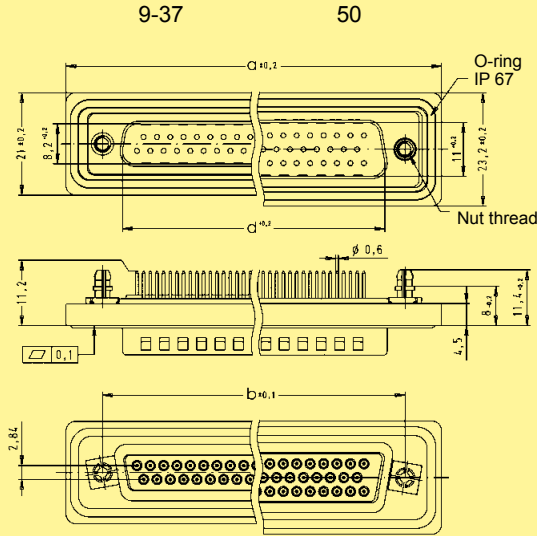

Female connector
9 – 50 contacts

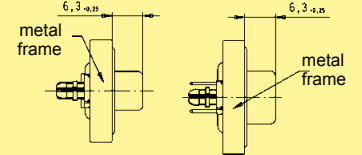
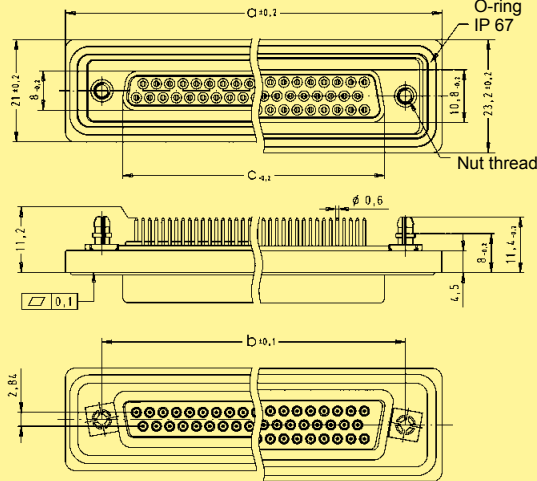

	a	b	c	d	g	h
9	40.0	25.00	16.4	16.9	4 x 2.74 = 10.96	3 x 2.74 = 8.22
15	48.3	33.30	24.7	25.2	7 x 2.74 = 19.18	6 x 2.74 = 16.44
25	62.0	47.04	38.5	38.9	12 x 2.76 = 33.12	11 x 2.76 = 30.36
37	78.5	63.50	54.9	55.3	18 x 2.76 = 49.68	17 x 2.76 = 46.92
50	76.1	61.10	52.5	52.8	16 x 2.76 = 44.16	15 x 2.76 = 41.40

Board drillings

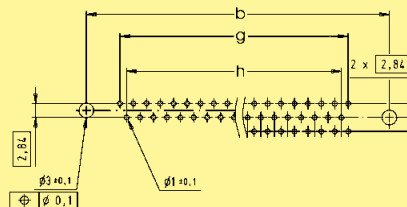

Number of contacts

9-25



IP 67, angled turned solder pins,
with rear plastic mounting plate, bracket and board lock

Identification	No. of contacts	Part No.	
		S4 ¹⁾	
Male connector metal shell with dimples	9 15 25	09 67 509 .	658
		09 67 515 .	658
		09 67 525 .	658
Please insert digit for flange thread			
4-40 UNC ▶	7		
M3 ▶	9		
Female connector metal shell	9 15 25	09 67 509 .	758
		09 67 515 .	758
		09 67 525 .	758
Please insert digit for flange thread			
4-40 UNC ▶	6		
M3 ▶	8		

D-Sub - W

¹⁾ S4 = 0.76 µm (30 µinch) Au or PdNi equivalent

Number of contacts

9-25



IP 67, angled turned solder pins,
with rear plastic mounting plate, bracket and board lock

Identification

Drawing

Dimensions in mm

Male connector
9 – 25 contacts

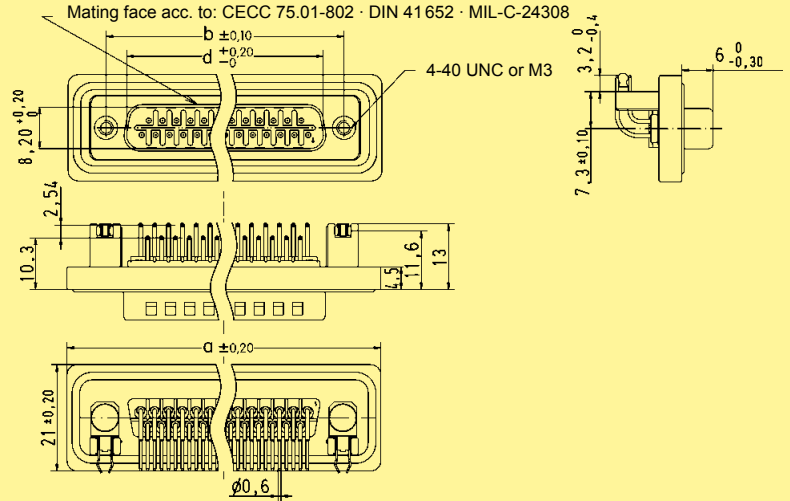

Female connector
9 – 25 contacts

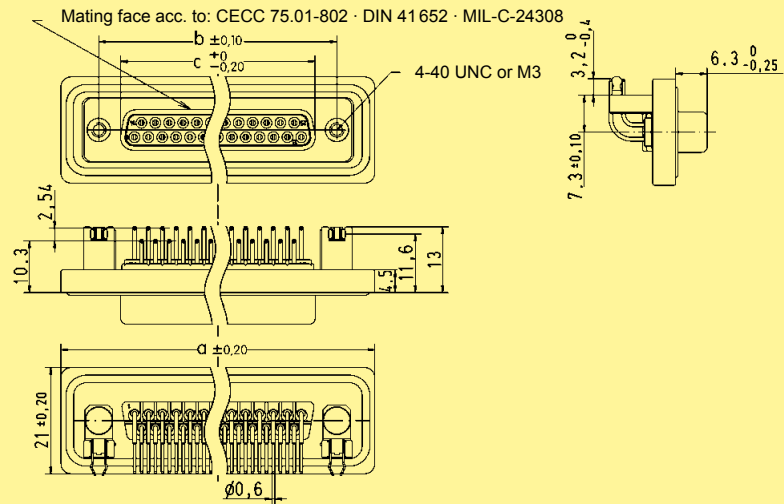

	a	b	c	d	g	h	i
9	40.0	25.00	16.4	16.9	4 x 2.74 = 10.96	3 x 2.74 = 8.22	25.0
15	48.3	33.30	24.7	25.2	7 x 2.74 = 19.18	6 x 2.74 = 16.44	33.3
25	62.0	47.04	38.5	38.9	12 x 2.76 = 33.12	11 x 2.76 = 30.36	47.0

Board drillings

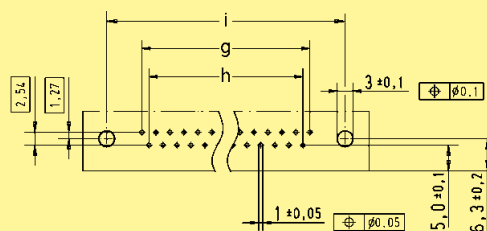

D-Sub - W

Number of contacts

9-50

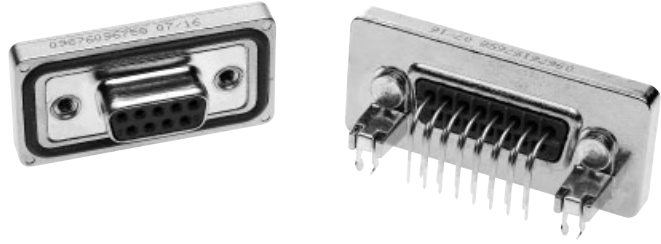

IP 67, angled turned solder pins,
with rear metal mounting plate, bracket and board lock

Identification	No. of contacts	Part No.	
		S4 ¹⁾	
Male connector metal shell with dimples			
	9	09 67 609	658
	15	09 67 615	658
	25	09 67 625	658
	37	09 67 637	658
	50	09 67 650	658
Please insert digit for flange thread			
4-40 UNC ▶	7		
M3 ▶	9		
Female connector metal shell			
	9	09 67 609	758
	15	09 67 615	758
	25	09 67 625	758
	37	09 67 637	758
	50	09 67 650	758
Please insert digit for flange thread			
4-40 UNC ▶	6		
M3 ▶	8		

D-Sub - W

¹⁾ S4 = 0.76 µm (30 µinch) Au or PdNi equivalent

Number of contacts

9-50

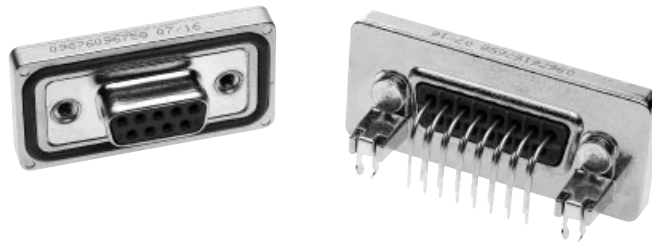

IP 67, angled turned solder pins,
with rear metal mounting plate, bracket and board lock

Identification

Drawing

Dimensions in mm

Male connector
9 – 50 contacts

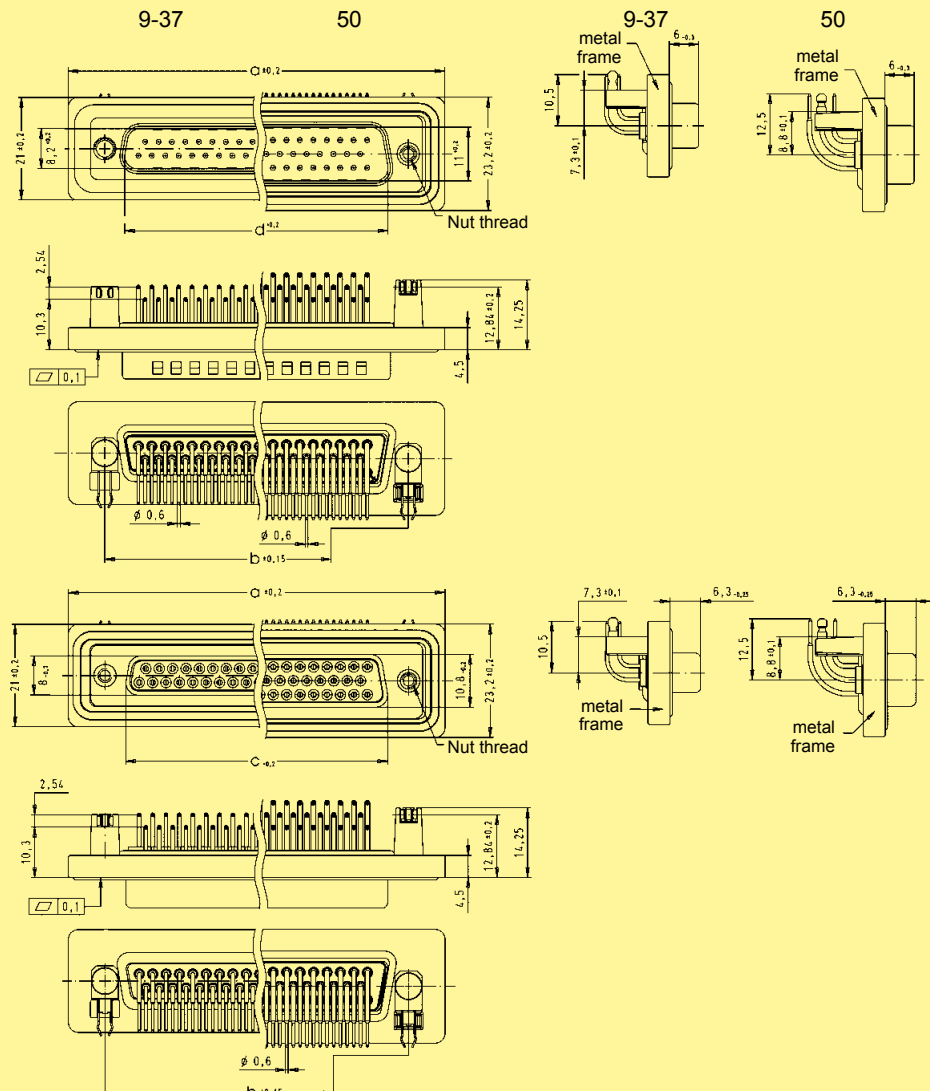

Female connector
9 – 50 contacts

	a	b	c	d	g	h
9	40.0	25.00	16.4	16.9	4 x $2.74 = 10.96$	3 x $2.74 = 8.22$
15	48.3	33.30	24.7	25.2	7 x $2.74 = 19.18$	6 x $2.74 = 16.44$
25	62.0	47.04	38.5	38.9	12 x $2.76 = 33.12$	11 x $2.76 = 30.36$
37	78.5	63.50	54.9	55.3	18 x $2.76 = 49.68$	17 x $2.76 = 46.92$
50	76.1	61.10	52.5	52.8	16 x $2.76 = 44.16$	15 x $2.76 = 41.40$

Board drillings

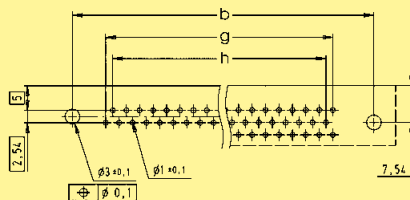



IP 67 plastic hoods

IP 67 metallized plastic hoods

Identification No. of contacts Part No. Drawing Dimensions in mm

Hood¹⁾

Black thermoplastic

9	09 67 009 043
15	09 67 015 043
25	09 67 025 043
37	09 67 037 043
50	09 67 050 043

Metallized thermo-
plastic

9	09 67 009 053
15	09 67 015 053
25	09 67 025 053
37	09 67 037 053
50	09 67 050 053

Please insert digit
for screw option

Locking screw,
thread 4-40 UNC ▶ 8

Locking screw,
thread M3 ▶ 9

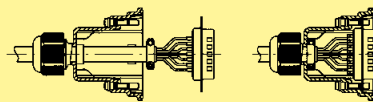
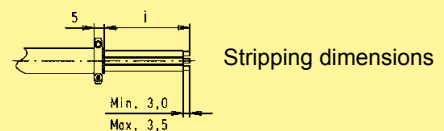
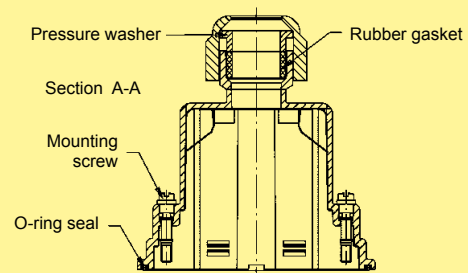
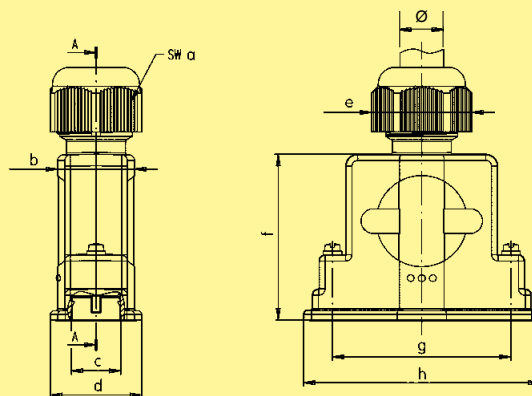



Mounting instructions:

- The peeled back cable braiding must not extend over the cable clamp, in order not to damage the gasket or to impair its performance.
- Pull back cable until cable clamp snaps into shielding plate.
- Snap connector into hood.

	a	b	c	d	e	f	g	h	i	Ø	
										min.	max.
9	20	16.5	13.0	20.2	22.1	36.4	25.0	39.8	18.0	6.0	8.0
15	24	16.5	13.0	20.2	26.6	36.4	33.3	48.5	18.0	6.0	10.5
25	24	20.3	13.0	24.0	26.6	43.6	47.0	62.3	45.0	8.0	12.0
37	24	20.3	13.0	24.0	26.6	52.1	63.5	78.6	60.0	8.0	12.0
50	29	22.0	16.0	27.6	32.1	52.1	61.1	75.7	60.0	9.0	14.0

¹⁾ Not to be used with 9 to 50 pole crimp connectors

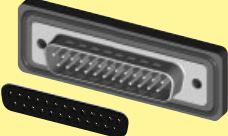
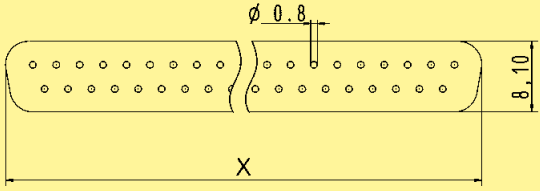
Accessories for IP 67 connectors

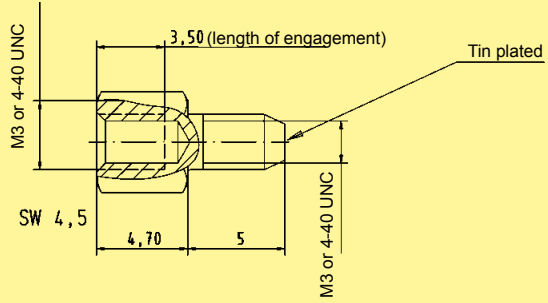
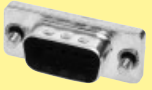
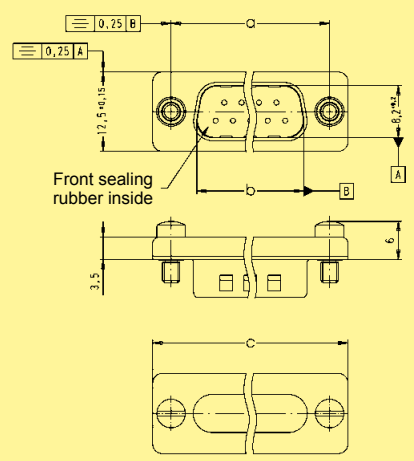
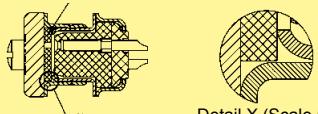
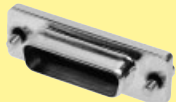
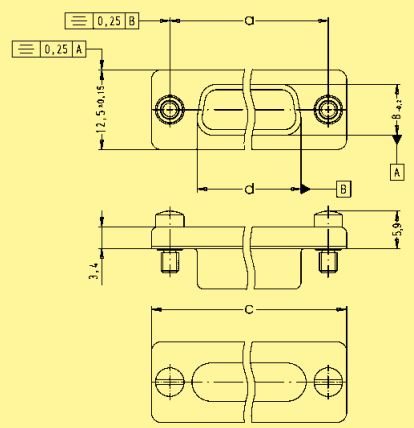
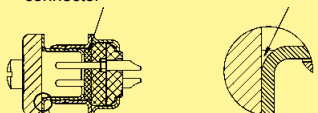
Identification	No. of contacts	Part No.	Drawing	Dimensions in mm																				
Front sealing rubber¹⁾ IP 67  Mounting example 	9 15 25	09 67 002 9001 09 67 002 9002 09 67 002 9003		<table border="1"> <thead> <tr> <th></th> <th>X</th> </tr> </thead> <tbody> <tr> <td>9</td> <td>16.7</td> </tr> <tr> <td>15</td> <td>24.8</td> </tr> <tr> <td>25</td> <td>38.8</td> </tr> </tbody> </table>		X	9	16.7	15	24.8	25	38.8												
	X																							
9	16.7																							
15	24.8																							
25	38.8																							
Female screw lock and spacing washer²⁾ M3  4-40 UNC 2) Order 2 for each connector		09 67 002 9006 09 67 002 9007																						
Dust cap for female connectors³⁾ M3  4-40 UNC 3) With inside glued front sealing rubber	9 15 25 9 15 25	09 67 002 9055 09 67 002 9056 09 67 002 9057 09 67 002 9050 09 67 002 9051 09 67 002 9052	 <p>IP 67 shielding concept Front seal glued to shielding dust cap</p>  <p>Detail X (Scale 5:1)</p> <table border="1"> <thead> <tr> <th></th> <th>a</th> <th>b</th> <th>c</th> <th>d</th> </tr> </thead> <tbody> <tr> <td>9</td> <td>25.00</td> <td>16.9</td> <td>30.8</td> <td>16.4</td> </tr> <tr> <td>15</td> <td>33.30</td> <td>25.2</td> <td>39.1</td> <td>24.7</td> </tr> <tr> <td>25</td> <td>47.04</td> <td>38.9</td> <td>53.0</td> <td>38.5</td> </tr> </tbody> </table>		a	b	c	d	9	25.00	16.9	30.8	16.4	15	33.30	25.2	39.1	24.7	25	47.04	38.9	53.0	38.5	
	a	b	c	d																				
9	25.00	16.9	30.8	16.4																				
15	33.30	25.2	39.1	24.7																				
25	47.04	38.9	53.0	38.5																				
Dust cap for male connectors⁴⁾ M3  4-40 UNC 4) Order separately the front sealing rubber for an IP 67 performance	9 15 25 9 15 25	09 67 002 9065 09 67 002 9066 09 67 002 9067 09 67 002 9060 09 67 002 9061 09 67 002 9062	 <p>IP 67 shielding concept Front sealing rubber is mounted in male connector</p>  <p>Detail Y (Scale 5:1)</p>																					

D-Sub - W

¹⁾ The front sealing rubber is to be used with hood 09 67 0xx 0436 and 09 67 0xx 0437 when a mated system needs to have the IP 67 performance; in this case, the front sealing rubber is positioned in the IP 67 male connector prior to the mating operation with the facing IP 67 connector; it provides a full protection of the contacts at the mated area by preventing possible ingress of liquids or dust between the shells.

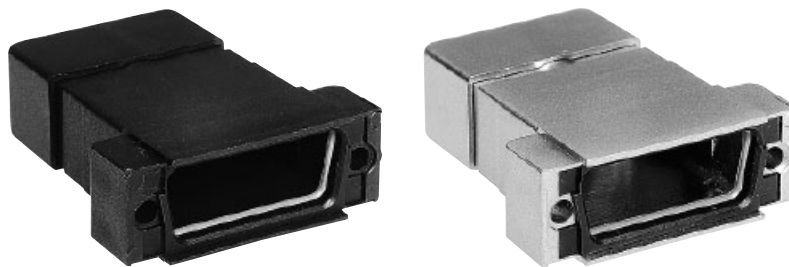

IP 67 plastic hoods
IP 67 metallized plastic hoods

Identification	No. of contacts	Part No.	Drawing	Dimensions in mm
----------------	-----------------	----------	---------	------------------

Hood
Black thermoplastic

9	09 67 009 0436
15	09 67 015 0436
25	09 67 025 0436

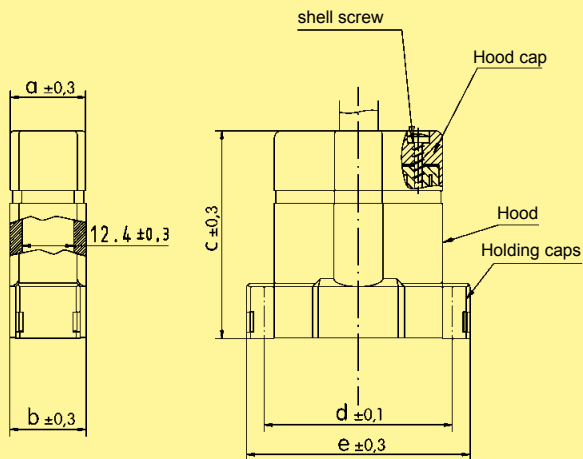

Metallized thermoplastic

9	09 67 009 0437
15	09 67 015 0437
25	09 67 025 0437

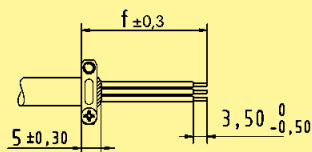





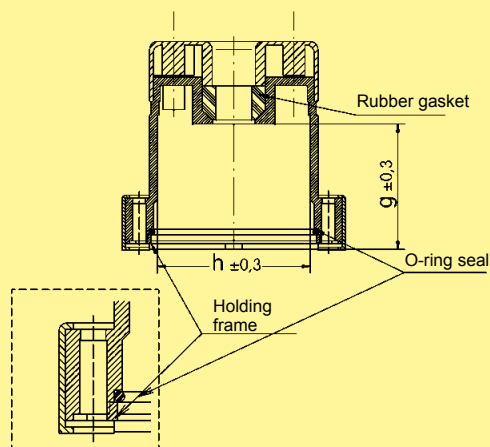
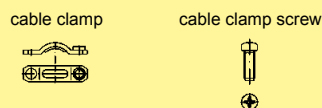

Mounting instructions

The stripped braid should not be fold back to avoid damaging the cable clamp and reducing its performance.

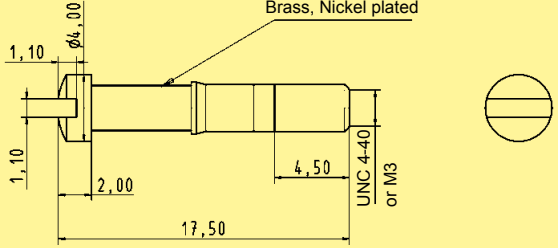

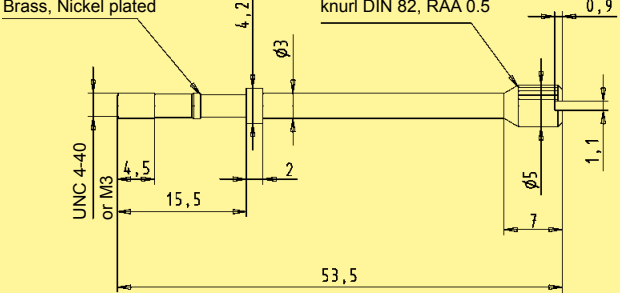
	a	b	c	d	e	f	g	h
9	15.6	15.6	41.0	25.00	33.6	23.0	25.0	17.0
15	15.6	15.6	46.8	33.30	42.0	27.5	30.8	25.1
25	18.8	19.1	52.0	47.04	55.7	31.5	33.8	38.8

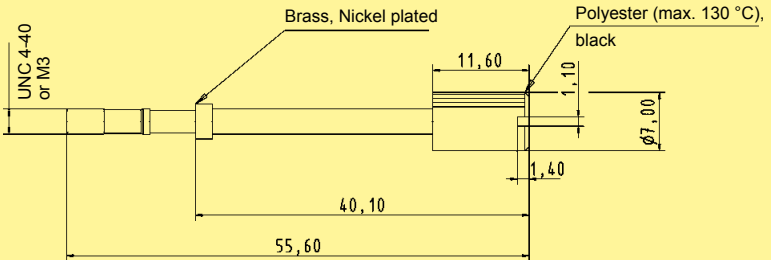
Accessories for IP 67 hoods

Identification	No. of contacts	Part No.	Drawing	Dimensions in mm
Short locking screw 4-40 UNC 		09 67 002 9008		
Short locking screw M3 		09 67 002 9009		
Knurled locking screw 4-40 UNC 		09 67 002 9010		
Knurled locking screw M3 		09 67 002 9011		
Knurled locking screw 4-40 UNC with plastic cap 		09 67 002 9012		
Knurled locking screw M3 with plastic cap 		09 67 002 9013		

D-Sub - W

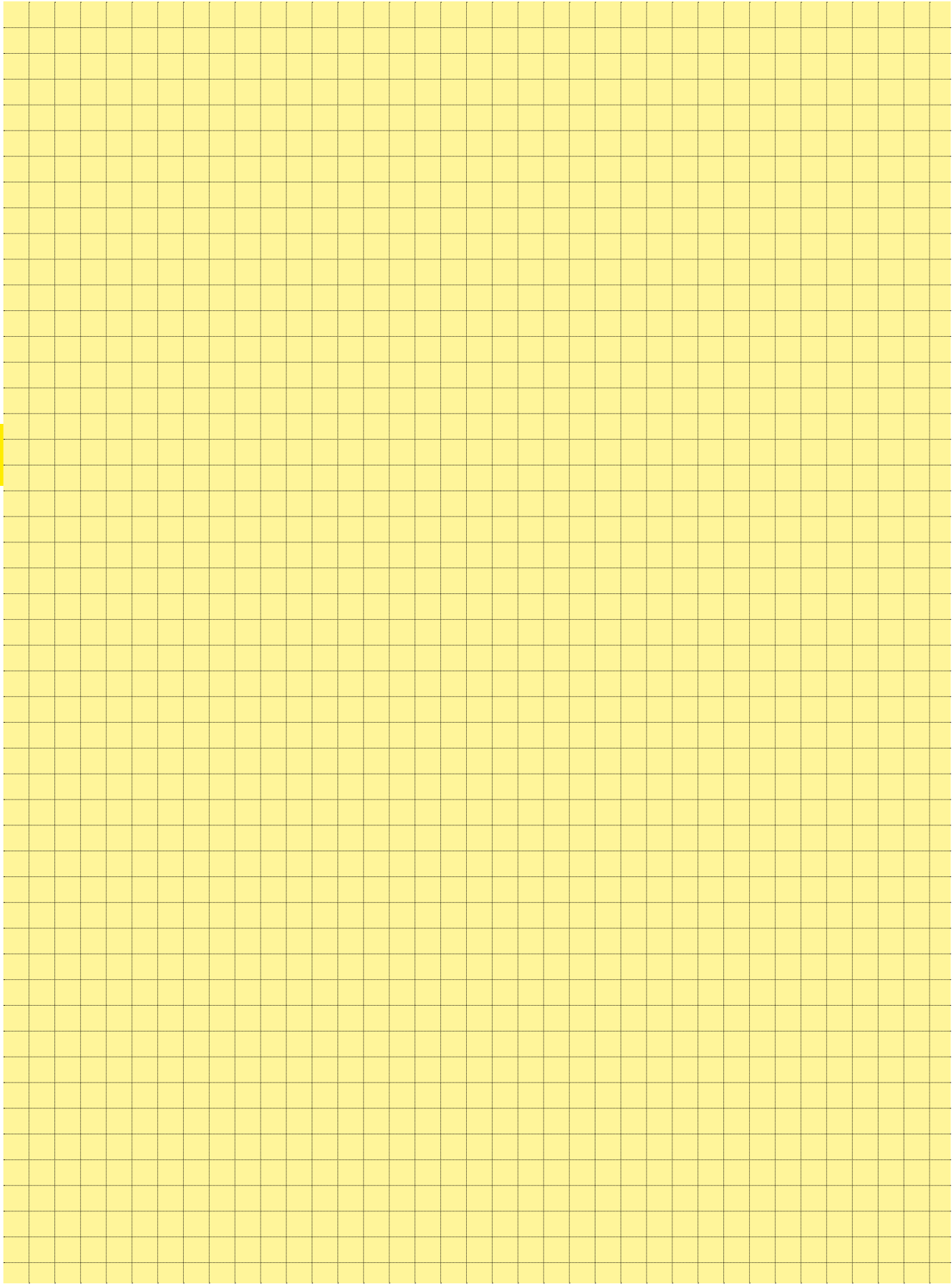

D-Sub - W

D-Sub – Housing range for subminiature D connectors

Page

General information – hoods for screw locking		07.02
Thermoplastic top and side entry hoods with knurled or short screws		07.04
Thermoplastic side entry hoods with knurled screws		07.06
Thermoplastic top entry hoods with knurled or locking screws		07.07
Full metal top and side entry hoods with knurled screws		07.08
Full metal top and side entry hoods with short screws		07.09
Full metal top entry hoods with premounted threaded inserts		07.10
Full metal top and side entry hoods with different screw options		07.11
General information – hoods for spring or slide locking		07.14
Thermoplastic top and side entry hoods for spring or slide locking		07.15
Full metal top and side entry hoods for spring or slide locking		07.16
Accessories		07.17
InduCom 9 – Industrial bus interface system		07.22

D-Sub - H

HARTING – Guarantee a secure connection

Modern electronic applications demand a high degree of mechanical and electrical security. To meet these requirements, continuous screening from the cable to the PCB via the connector is achieved by using state of the art components to DIN 41 652.

utilise various combinations of male and female connectors with hoods, featuring either screw locking or latching facilities.

Only 2 examples are shown:

- Continuous security screening and grounding with screw locking and metallized hood.
- Continuous grounding and vibration proof latching system with metallized hood.

HARTING offer many solutions. These

Male connector with dimples

Screw lock

Cable with protective screen

Strain relief

Metallized hood

Female connector with protective metal shell

Grounding contact between protective metal shell and PCB

Female connector with protective metal shell

Spring latch

Strain relief

Cable with protective screen

Metallized hood

Male connector with dimples

Number of contacts in the D-Sub standard/D-Sub high density range related to the shell size.

Shell size	D-Sub standard	D-Sub high density
1	9	15
2	15	26
3	25	44
4	37	62
5	50	78

Connector hoods for screw locking

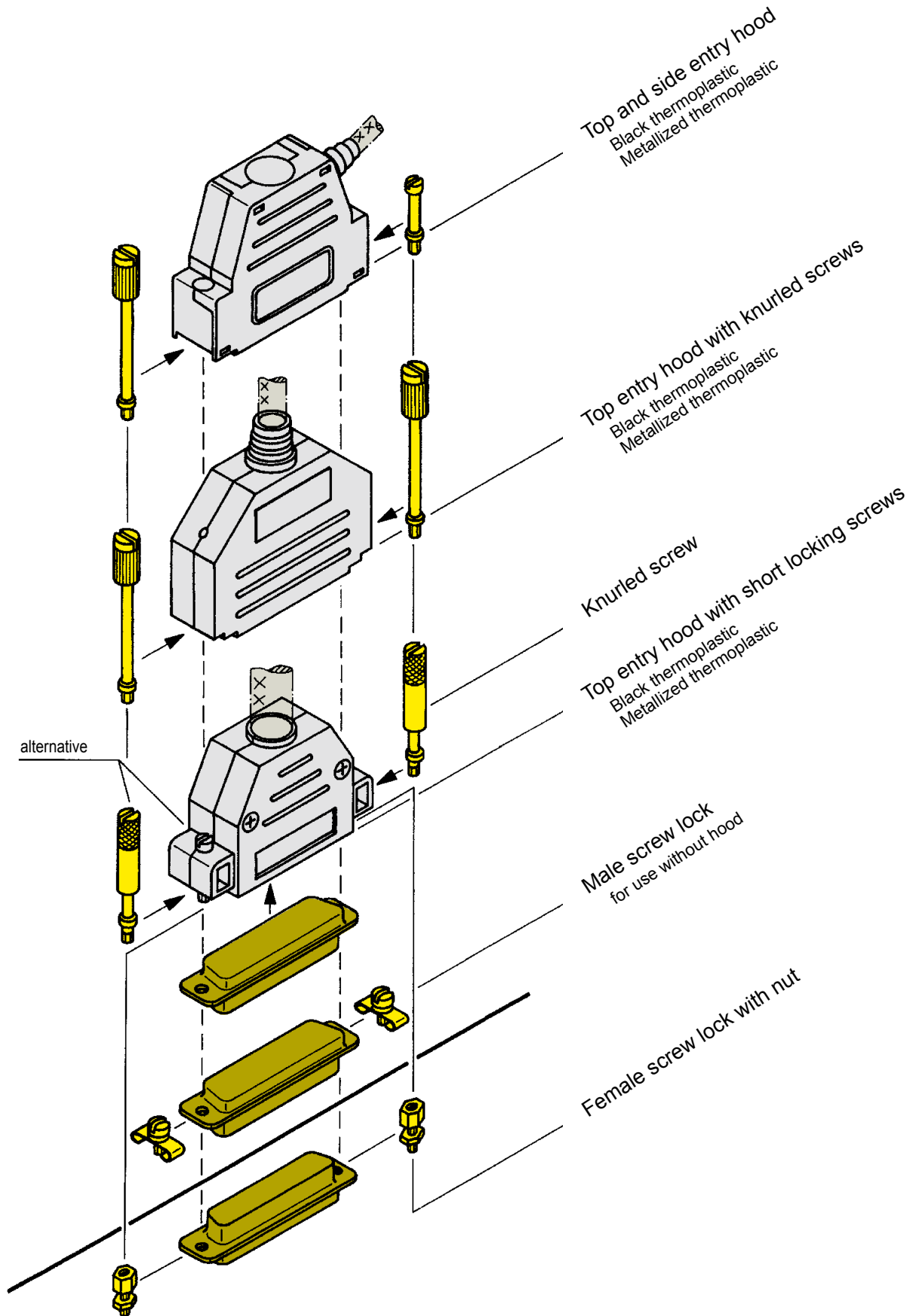

D-Sub - H

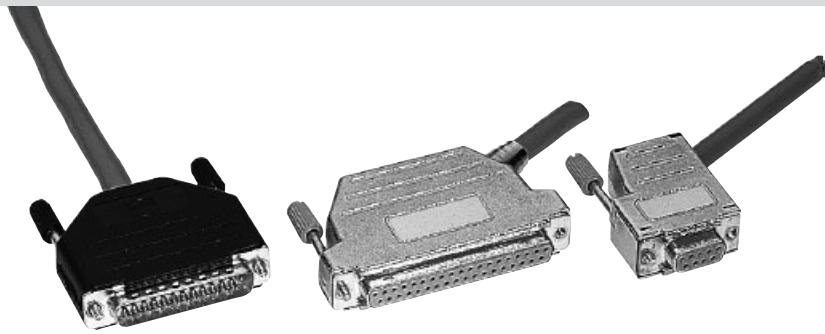

Top and side entry hoods with knurled screws

Identification	No. of contacts	Part No.	Drawing	Dimensions in mm																																																
Top entry hood Black thermoplastic	9	09 67 009 042		<table border="1"> <thead> <tr> <th></th> <th>A1</th> <th>A2</th> <th>B</th> <th>C1</th> <th>C2</th> <th>max. Ø 1</th> <th>max. Ø 2</th> </tr> </thead> <tbody> <tr> <td>9</td> <td>31.5</td> <td>32.5</td> <td>15</td> <td>34</td> <td>38</td> <td>8.0</td> <td>11.5</td> </tr> <tr> <td>15</td> <td>40.0</td> <td>41.0</td> <td>15</td> <td>34</td> <td>38</td> <td>11.5</td> <td>11.5</td> </tr> <tr> <td>25</td> <td>53.5</td> <td>54.5</td> <td>15</td> <td>40</td> <td>40</td> <td>11.5</td> <td>11.5</td> </tr> <tr> <td>37</td> <td>71.0</td> <td>71.0</td> <td>15</td> <td>40</td> <td>40</td> <td>11.5</td> <td>11.5</td> </tr> <tr> <td>50</td> <td>67.5</td> <td></td> <td>19</td> <td>40</td> <td></td> <td>14.0</td> <td></td> </tr> </tbody> </table>		A1	A2	B	C1	C2	max. Ø 1	max. Ø 2	9	31.5	32.5	15	34	38	8.0	11.5	15	40.0	41.0	15	34	38	11.5	11.5	25	53.5	54.5	15	40	40	11.5	11.5	37	71.0	71.0	15	40	40	11.5	11.5	50	67.5		19	40		14.0	
	A1	A2			B	C1	C2	max. Ø 1	max. Ø 2																																											
9	31.5	32.5			15	34	38	8.0	11.5																																											
15	40.0	41.0			15	34	38	11.5	11.5																																											
25	53.5	54.5			15	40	40	11.5	11.5																																											
37	71.0	71.0	15	40	40	11.5	11.5																																													
50	67.5		19	40		14.0																																														
Please insert digit for screw option	15	09 67 015 042																																																		
Knurled screw, thread 4-40 UNC ▶ 4 Knurled screw, thread M3 ▶ 6	25	09 67 025 042																																																		
	37	09 67 037 042																																																		
	50	09 67 050 042																																																		
Top entry hood Metallized thermoplastic	9	09 67 009 042																																																		
Please insert digit for screw option	15	09 67 015 042																																																		
Knurled screw, thread 4-40 UNC ▶ 5 Knurled screw, thread M3 ▶ 7	25	09 67 025 042																																																		
	37	09 67 037 042																																																		
Top and side entry hood Black thermoplastic	9 ³⁾	09 67 009 043																																																		
Please insert digit for screw option	15	09 67 015 043																																																		
Knurled screw, thread 4-40 UNC ▶ 4 Knurled screw, thread M3 ▶ 0	25	09 67 025 043																																																		
	37 ¹⁾	09 67 037 043																																																		
Top and side entry hood Metallized thermoplastic	9 ³⁾	09 67 009 043		<table border="1"> <thead> <tr> <th></th> <th>A</th> <th>B</th> </tr> </thead> <tbody> <tr> <td>9</td> <td>31.5</td> <td>40</td> </tr> <tr> <td>15</td> <td>40.0</td> <td>40</td> </tr> <tr> <td>25</td> <td>53.5</td> <td>43</td> </tr> <tr> <td>37</td> <td>71.3</td> <td>40</td> </tr> </tbody> </table>		A	B	9	31.5	40	15	40.0	40	25	53.5	43	37	71.3	40																																	
	A	B																																																		
9	31.5	40																																																		
15	40.0	40																																																		
25	53.5	43																																																		
37	71.3	40																																																		
Please insert digit for screw option	15	09 67 015 043																																																		
Knurled screw, thread 4-40 UNC ▶ 5 Knurled screw, thread M3 ▶ 1	25 ²⁾	09 67 025 043																																																		
	37 ¹⁾	09 67 037 043																																																		

1) 37 pole is only available with side entry and with knurled screw, thread 4-40 UNC
 2) Cable clamp kit for two outputs is available as accessories (it includes: screw, metal clamp, plastic insert and grommet). With Part No. 09 67 001 9988 ten of these kits are delivered.
 3) 9 pole hood provided with only one screw on the opposite side of the cable entry.



Top and side entry hoods with short screws

Identification	No. of contacts	Part No.	Drawing	Dimensions in mm																								
Top and side entry hood Black thermoplastic Please insert digit for screw option Short screw, thread 4-40 UNC ▶ 3 Short screw, thread M3 ▶ 2	9 ¹⁾ 15 25 37	09 67 009 046 . 09 67 015 046 . 09 67 025 046 . 09 67 037 046 .		<table border="1"> <thead> <tr> <th></th> <th>A</th> <th>B</th> </tr> </thead> <tbody> <tr> <td>9</td> <td>31.5</td> <td>40</td> </tr> <tr> <td>15</td> <td>40.0</td> <td>40</td> </tr> <tr> <td>25</td> <td>53.5</td> <td>43</td> </tr> <tr> <td>37</td> <td>71.3</td> <td>40</td> </tr> </tbody> </table>		A	B	9	31.5	40	15	40.0	40	25	53.5	43	37	71.3	40									
	A	B																										
9	31.5	40																										
15	40.0	40																										
25	53.5	43																										
37	71.3	40																										
Top and side entry hood Metallized thermoplastic Please insert digit for screw option Short screw, thread 4-40 UNC ▶ 5 Short screw, thread M3 ▶ 4	9 ¹⁾ 15 25 37	09 67 009 046 . 09 67 015 046 . 09 67 025 046 . 09 67 037 046 .																										
Spares Knurled screw, thread 4-40 UNC Insert for metallized hoods Cable clamp Cable clamp screw	9-25 9-15 25-37 9-15 25-37 9-37	09 67 002 9081 09 67 002 9103 09 67 002 9105 09 67 002 9104 09 67 002 9106 09 67 002 9102																										
Grommet for black thermoplastic hood for metallized hood		09 67 001 9968 09 67 002 9075		<table border="1"> <thead> <tr> <th colspan="2">max. Ø</th> </tr> <tr> <th>... 9968</th> <th>... 9075</th> </tr> </thead> <tbody> <tr> <td>3.3</td> <td>3.5</td> </tr> <tr> <td>4.3</td> <td>4.5</td> </tr> <tr> <td>5.3</td> <td>5.5</td> </tr> <tr> <td>6.3</td> <td>6.5</td> </tr> </tbody> </table> <table border="1"> <thead> <tr> <th colspan="2">max. Ø</th> </tr> <tr> <th>... 9968</th> <th>... 9075</th> </tr> </thead> <tbody> <tr> <td>7.3</td> <td>7.5</td> </tr> <tr> <td>8.3</td> <td>8.5</td> </tr> <tr> <td>9.3</td> <td>9.5</td> </tr> <tr> <td>10.3</td> <td>10.5</td> </tr> </tbody> </table>	max. Ø		... 9968	... 9075	3.3	3.5	4.3	4.5	5.3	5.5	6.3	6.5	max. Ø		... 9968	... 9075	7.3	7.5	8.3	8.5	9.3	9.5	10.3	10.5
max. Ø																												
... 9968	... 9075																											
3.3	3.5																											
4.3	4.5																											
5.3	5.5																											
6.3	6.5																											
max. Ø																												
... 9968	... 9075																											
7.3	7.5																											
8.3	8.5																											
9.3	9.5																											
10.3	10.5																											

¹⁾ 9 pole hood provided with only one screw on the opposite side of the cable entry.
 Operating temperature for all hoods on this page: -55 °C ... +110 °C

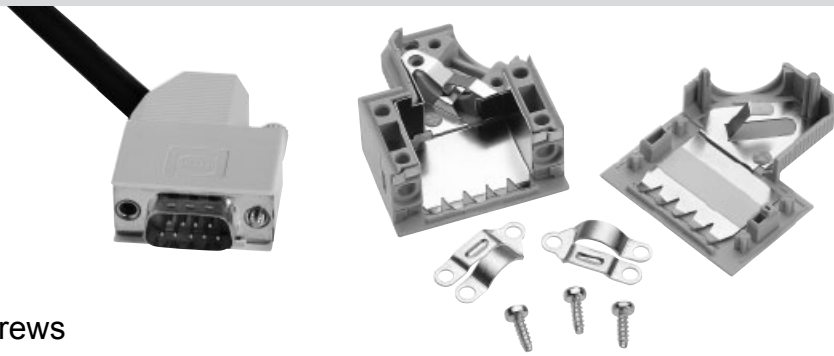

Side entry hoods with knurled screws

Identification	No. of contacts	Part No.	Drawing	Dimensions in mm																																				
Hood¹⁾ grey thermoplastic RAL 7032 grey thermoplastic with internal tin-plate screening 9-37 way for packaging density of 3 TE (15.24 mm)	9	09 67 009 0571	Upper hood part Lower hood part 9 contacts 15 – 50 contacts <table border="1"> <thead> <tr> <th></th> <th>a max.</th> <th>b min.</th> <th>c</th> <th>d</th> <th>e</th> <th>f</th> </tr> </thead> <tbody> <tr> <td>15</td> <td>39.62</td> <td>28.40</td> <td>13.00</td> <td>14.00</td> <td>1.00</td> <td>7.50</td> </tr> <tr> <td>25</td> <td>53.52</td> <td>42.20</td> <td>13.00</td> <td>14.00</td> <td>1.00</td> <td>7.50</td> </tr> <tr> <td>37</td> <td>69.80</td> <td>58.65</td> <td>13.00</td> <td>14.00</td> <td>1.00</td> <td>7.50</td> </tr> <tr> <td>50</td> <td>67.41</td> <td>56.18</td> <td>16.00</td> <td>17.50</td> <td>1.50</td> <td>9.50</td> </tr> </tbody> </table>		a max.	b min.	c	d	e	f	15	39.62	28.40	13.00	14.00	1.00	7.50	25	53.52	42.20	13.00	14.00	1.00	7.50	37	69.80	58.65	13.00	14.00	1.00	7.50	50	67.41	56.18	16.00	17.50	1.50	9.50	Max. 38,15 Max. 31,3	Max. 38,15 Min. 19,7 Max. 31,3 13 14
		a max.		b min.	c	d	e	f																																
	15	39.62		28.40	13.00	14.00	1.00	7.50																																
	25	53.52		42.20	13.00	14.00	1.00	7.50																																
	37	69.80		58.65	13.00	14.00	1.00	7.50																																
	50	67.41		56.18	16.00	17.50	1.50	9.50																																
	15	09 67 015 0571																																						
	25	09 67 025 0571																																						
	37	09 67 037 0571																																						
	50	09 67 050 0571																																						
9	09 67 009 0573																																							
15	09 67 015 0573																																							
25	09 67 025 0573																																							
37	09 67 037 0573																																							
50	09 67 050 0573																																							
Knurled screw Thread UNC Thread M3 Thread UNC Thread M3	9-50	09 67 000 9971 ²⁾ 09 67 001 9965*	Grey head / Nickel plated steel	Full metal part																																				
		09 67 001 9978 09 67 001 9977																																						
Tooling⁴⁾ for assembly of hoods Top part Bottom part		09 99 000 0215*																																						
		09 99 000 0216*																																						

D-Sub - H

07
06

* Not normally kept in stock
¹⁾ Order knurled screw separately
²⁾ 9 way 1 per hood – 15-50 way 2 per hood

³⁾ Screw driver type ISO PH 1 for philips screw No 1 ISO norm 4757
⁴⁾ Additional tooling (bench press) see chapter 32
 Operating temperature for all hoods on this page: -30 °C ... +100 °C



Top entry hoods with knurled or locking screws

Identification No. of contacts Part No. Drawing Dimensions in mm

Hood³⁾ Black thermoplastic with short locking screws	9	09 67 009 0442
	15	09 67 015 0442
	25	09 67 025 0442
	37	09 67 037 0442
	50	09 67 050 0442

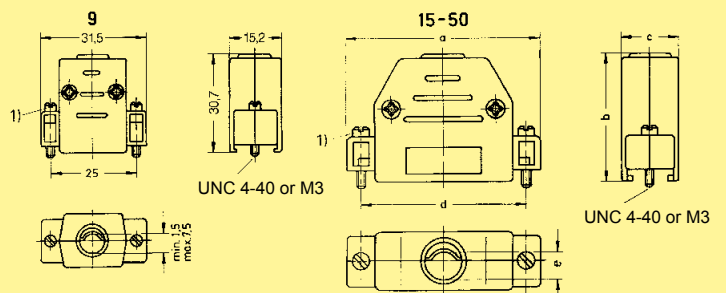

Hood³⁾ Metallized thermoplastic with short locking screws Please insert digit for screw option Thread 4-40 UNC ▶ 4 Thread M3 ▶ 2	9	09 67 009 04	3
	15	09 67 015 04	3
	25	09 67 025 04	3
	37	09 67 037 04	3
	50	09 67 050 04	3

	a	b	c	d	e	
					min.	max.
15	40.0	34.7	15.2	33.3	3.3	8.5
25	53.2	39.7	15.2	47.0	3.5	11.0
37	70.0	39.7	15.2	63.5	3.5	11.0
50	67.5	39.7	18.2	61.1	9.3	12.0

Knurled screw for metallized hood Thread UNC Thread M3	9-50	09 67 000 9925 ²⁾
	9-50	09 67 000 9930 ²⁾

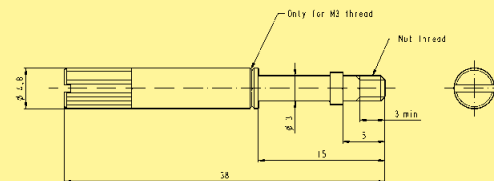

Screened hood Order cover and internal metal screen separately Cover⁴⁾ Black thermoplastic with knurled screws	9	09 67 009 0422
	15	09 67 015 0422
	25	09 67 025 0422
	37	09 67 037 0422

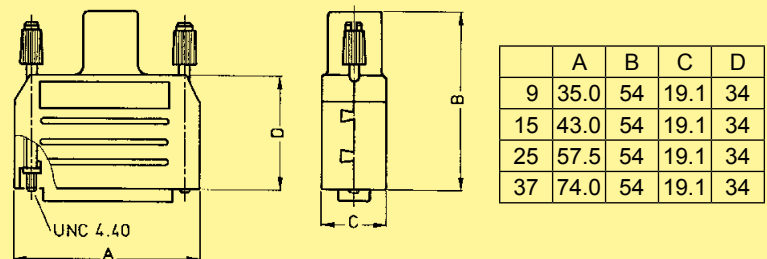

	A	B	C	D
9	35.0	54	19.1	34
15	43.0	54	19.1	34
25	57.5	54	19.1	34
37	74.0	54	19.1	34

Internal metal screen⁴⁾ metallized (Crimp tool see chapter 31)	9	09 67 009 0421
	15	09 67 015 0421
	25	09 67 025 0421
	37	09 67 037 0421

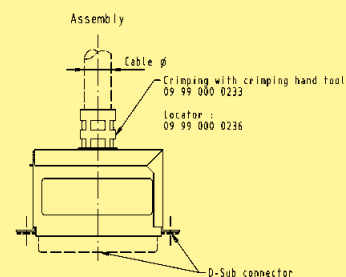

	Cable Ø (mm)	
	min.	max.
9	6.1	8.8
15	6.1	8.8
25	8.0	10.3
37	9.5	11.5

1) Use of knurled screws is possible. Please order separately
 2) Order 2 for each hood
 3) Operating temperature: -20 °C ... +90 °C
 4) Operating temperature: -55 °C ... +110 °C

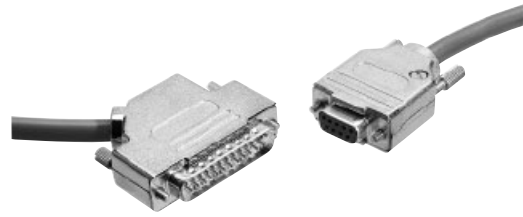

Full metal top and side entry hoods with knurled screws

Identification No. of contacts Part No. Drawing Dimensions in mm

Top entry hood
incl. grommet set
halves

Please insert digit for
screw option

- Knurled screw,
thread
4-40 UNC ▶ 3
- Knurled screw,
thread M3 ▶ 8

9	09 67 009 034
15	09 67 015 034
25	09 67 025 034
37	09 67 037 034
50	09 67 050 034

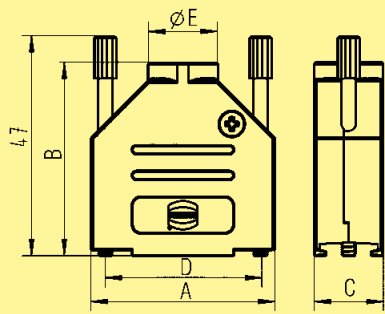

Poles	A	B	C	D	E
9	31.0	39.5	14.8	25.0	11.7
15	39.5	41.5	14.8	33.3	11.7
25	53.5	48.5	14.8	47.0	11.7
37	71.0	53.0	14.8	63.5	11.7
50	67.5	54.0	18.7	61.1	17.0

Spare knurled screw
thread 4-40 UNC
thread M3

09 67 002 9029
09 67 002 9101

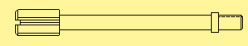

Side entry hood
incl. grommet set
halves

Please insert digit for
screw option

- Knurled screw,
thread
4-40 UNC ▶ 3
- Knurled screw,
thread M3 ▶ 6

9 ¹⁾	09 67 009 033
15	09 67 015 033
25	09 67 025 033
37	09 67 037 033
50	09 67 050 033

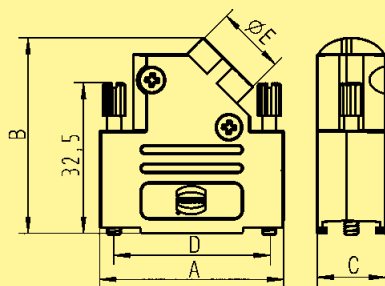

Poles	A	B	C	D	E
9	31.0	37.7	14.7	—	11.7
15	39.5	42.0	14.7	33.3	11.7
25	53.2	41.3	14.7	47.0	11.7
37	69.7	41.8	14.7	63.7	11.7
50	67.4	44.9	17.4	61.1	17.0

Spare knurled screw
thread 4-40 UNC
thread M3

09 67 002 9028
09 67 001 9997



Spare grommet set
halves

9-37 poles

09 67 002 9092

50 poles

09 67 002 9094

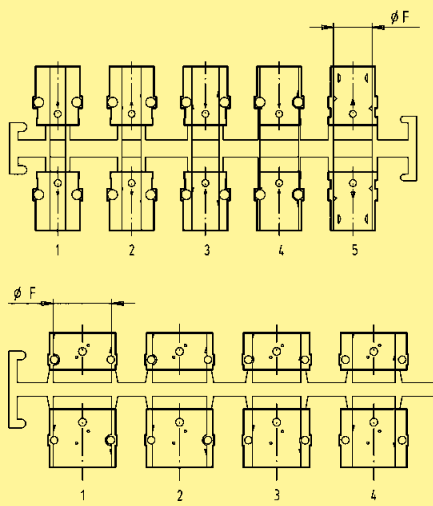

Grommet dimensions		
Number	Diameter F	
	9-37 poles	50 poles
1	4.0	15.0
2	5.0	14.0
3	7.0	12.5
4	9.0	11.0
5	10.2	—

¹⁾ 9 pole hood provided with only one screw on the opposite side of the cable entry.
Operating temperature for all hoods on this page: -40 °C ... +120 °C

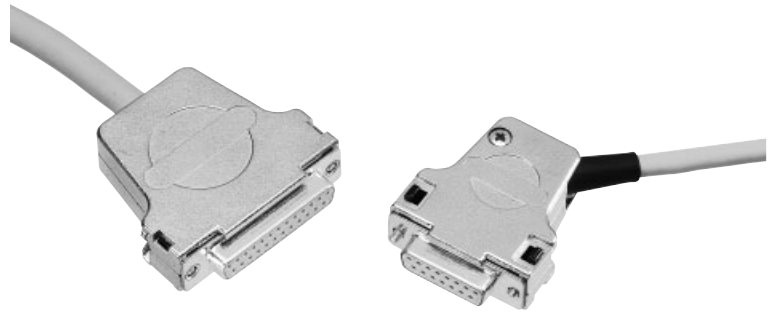

Full metal top and side entry hoods with short screws

Identification No. of contacts Part No. Drawing Dimensions in mm

Top entry hood

9	09 67 009 034
15	09 67 015 034
25	09 67 025 034
37	09 67 037 034
50	09 67 050 034

Please insert digit for screw option

- Locking screw, thread 4-40 UNC ▶ 4
- Locking screw, thread M3 ▶ 9

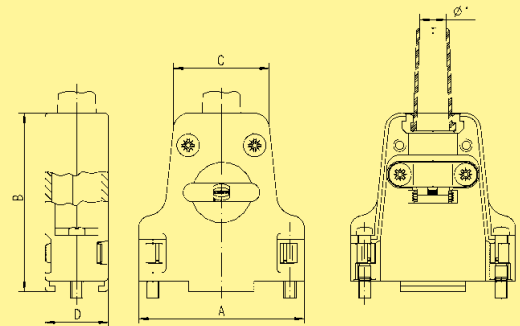

Poles	A	B	C	D	Ø F1		Ø F2	Ø F3
					Min.	Max.		
9	31.8	42.4	20.8	15.4	3.0	9.5	6.5	—
15	40.3	43.5	23.3	15.4	3.0	8.5	6.5	12.5
25	54.0	47.7	31.7	15.4	3.0	8.5	8.0	12.5
37	70.2	50.4	48.2	18.4	3.0	12.0	9.0	15.0
50	67.8	50.5	45.8	18.2	3.0	12.0	9.7	15.0

* Cable diameter without rubber bushing = Ø F1
 Cable diameter with rubber bushing = Ø F2
 Cable diameter without rubber bushing and without cable reduction plate = Ø F3

Side entry hood

9	09 67 009 033
15	09 67 015 033
25	09 67 025 033
37	09 67 037 033
50	09 67 050 033

Please insert digit for screw option

- Locking screw, thread 4-40 UNC ▶ 4
- Locking screw, thread M3 ▶ 5

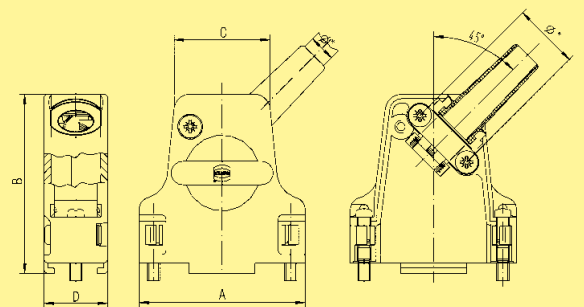

Spare short locking screw

thread 4-40 UNC
 thread M3

09 67 002 9090
09 67 002 9091



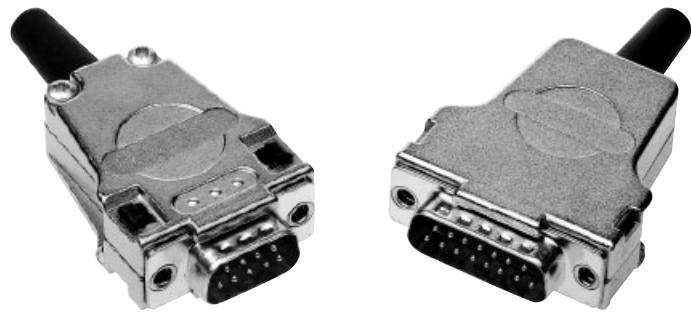

Full metal top entry hoods with premounted threaded inserts

Identification No. of contacts Part No. Drawing Dimensions in mm

Top entry hood

9	09 67 009 032
15	09 67 015 032
25	09 67 025 032
37	09 67 037 032
50	09 67 050 032

Please insert digit for premounted insert

- thread 4-40 UNC ▶ 2
- thread M3 ▶ 3

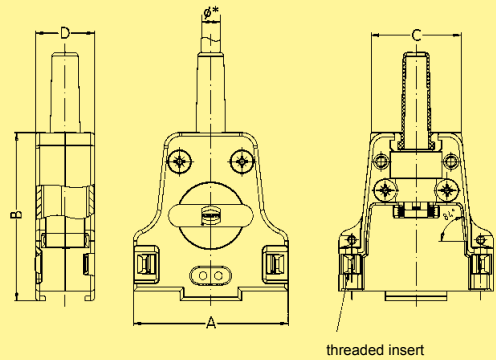

Poles	A	B	C	D	Ø F1		Ø F2	Ø F3
					Min.	Max.		
9	31.6	42.0	20.8	15.2	3.0	9.5	6.5	–
15	40.0	43.5	23.3	15.2	3.0	8.5	6.5	12.5
25	53.7	47.5	31.7	15.2	3.0	8.5	8.0	12.5
37	70.2	50.5	48.2	18.2	3.0	12.0	9.0	15.0
50	67.8	50.5	45.8	18.2	3.0	12.0	9.7	15.0

* Cable diameter without rubber bushing = Ø F1
 Cable diameter with rubber bushing = Ø F2
 Cable diameter without rubber bushing and without cable reduction plate = Ø F3

Locking hook

09 67 002 9031¹⁾

Latch lock bolt

Front mount

thread 4-40 UNC 09 67 002 9041¹⁾
 thread M3 09 67 002 9042¹⁾

Rear mount

thread 4-40 UNC 09 67 002 9032¹⁾
 thread M3 09 67 002 9040¹⁾

Cable to cable

thread 4-40 UNC 09 67 002 9044¹⁾
 thread M3 09 67 002 9045¹⁾

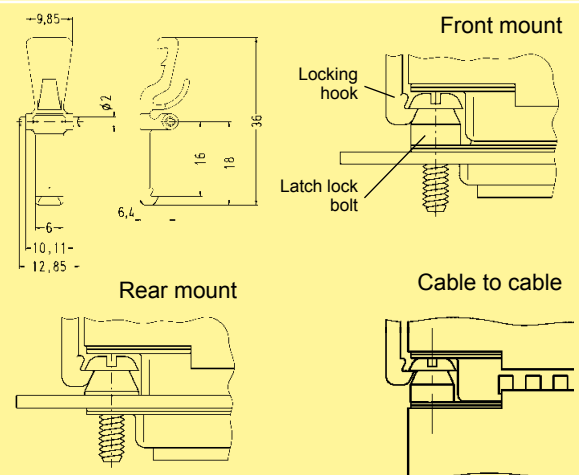

D-Sub - H

¹⁾ Order 2 for each hood
 Operating temperature for all hoods on this page: -35 °C ... +100 °C

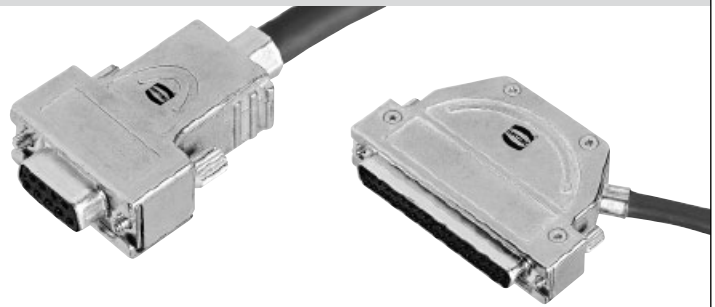

Full metal top and side entry hoods with different screw options

Identification No. of contacts Part No. Drawing Dimensions in mm

40° side entry hood

with internal grounding block

9	61 03 001 . 013
15	61 03 001 . 014
25	61 03 001 . 015

without internal grounding block

9	61 03 001 . 013 010
---	---------------------

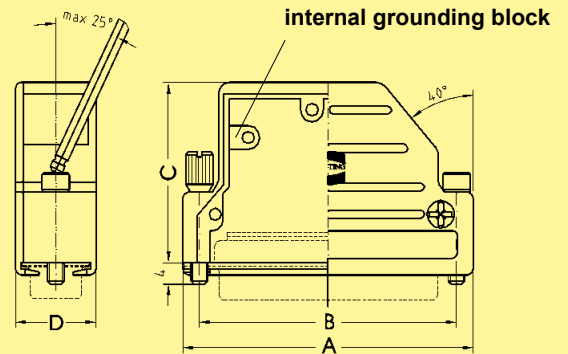

No. of contacts	A	B	C	D
9	31.0	25.0	35.0	15.0
15	39.3	33.3	35.0	15.0
25	53.0	47.0	35.0	15.0

Top/side entry hood

with internal grounding block

9	61 03 001 . 010
15	61 03 001 . 016
25	61 03 001 . 017 ¹⁾
37	61 03 001 . 018 ¹⁾
50	61 03 001 . 019 ¹⁾

without internal grounding block

9	61 03 001 . 010 010
---	---------------------

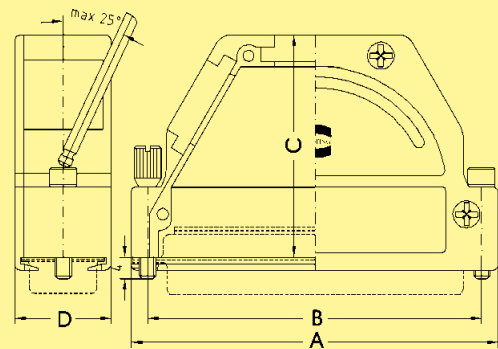

No. of contacts	No. of cable entries	A	B	C	D
9	1 (top)	31.0	25.0	38.0	15.0
15	1 (top)	39.5	33.3	35.0	15.0
25	3	53.0	47.0	43.0	15.0
37	3	69.5	63.5	43.0	15.0
50	3	67.2	61.6	43.0	17.8

Please insert digit for screw option

- Knurled screw, thread 4-40 UNC ▶ 0
- Hexagonal screw, thread M3 with captive washer ▶ 1
- Hexagonal screw, thread 4-40 UNC with captive washer ▶ 2
- Knurled screw, thread M3 ▶ 3

D-Sub - H

¹⁾ Part No. contains two blanking pieces
Operating temperature for all hoods on this page: -20 °C ... +90 °C



Full metal top and side entry hoods with different screw options

Identification	No. of contacts	Part No.		Drawing	Dimensions in mm								
5° top entry hood with 3 cable entries with internal grounding block	37	61 03 001	118										
	50	61 03 001	119										
without internal grounding block	37	61 03 001	118 010										
	50	61 03 001	119 010										
<p>Please insert digit for screw option</p> <table border="1"> <tr> <td>Knurled screw, thread 4-40 UNC</td> <td>▶ 0</td> </tr> <tr> <td>Hexagonal screw, thread M3 with captive washer</td> <td>▶ 1</td> </tr> <tr> <td>Hexagonal screw, thread 4-40 UNC with captive washer</td> <td>▶ 2</td> </tr> <tr> <td>Knurled screw, thread M3</td> <td>▶ 3</td> </tr> </table>						Knurled screw, thread 4-40 UNC	▶ 0	Hexagonal screw, thread M3 with captive washer	▶ 1	Hexagonal screw, thread 4-40 UNC with captive washer	▶ 2	Knurled screw, thread M3	▶ 3
Knurled screw, thread 4-40 UNC	▶ 0												
Hexagonal screw, thread M3 with captive washer	▶ 1												
Hexagonal screw, thread 4-40 UNC with captive washer	▶ 2												
Knurled screw, thread M3	▶ 3												
Top entry hood for InduCom 9													
Hexagonal screw, thread 4-40 UNC	9	66 67 009 0346											
Hexagonal screw, thread M3	9	66 67 009 0347											

No. of contacts	A	B	C	D	E
37	69.5	52.0	58.2	14.8	63.5
50	67.1	58.0	63.6	17.6	61.1

2 cable entries

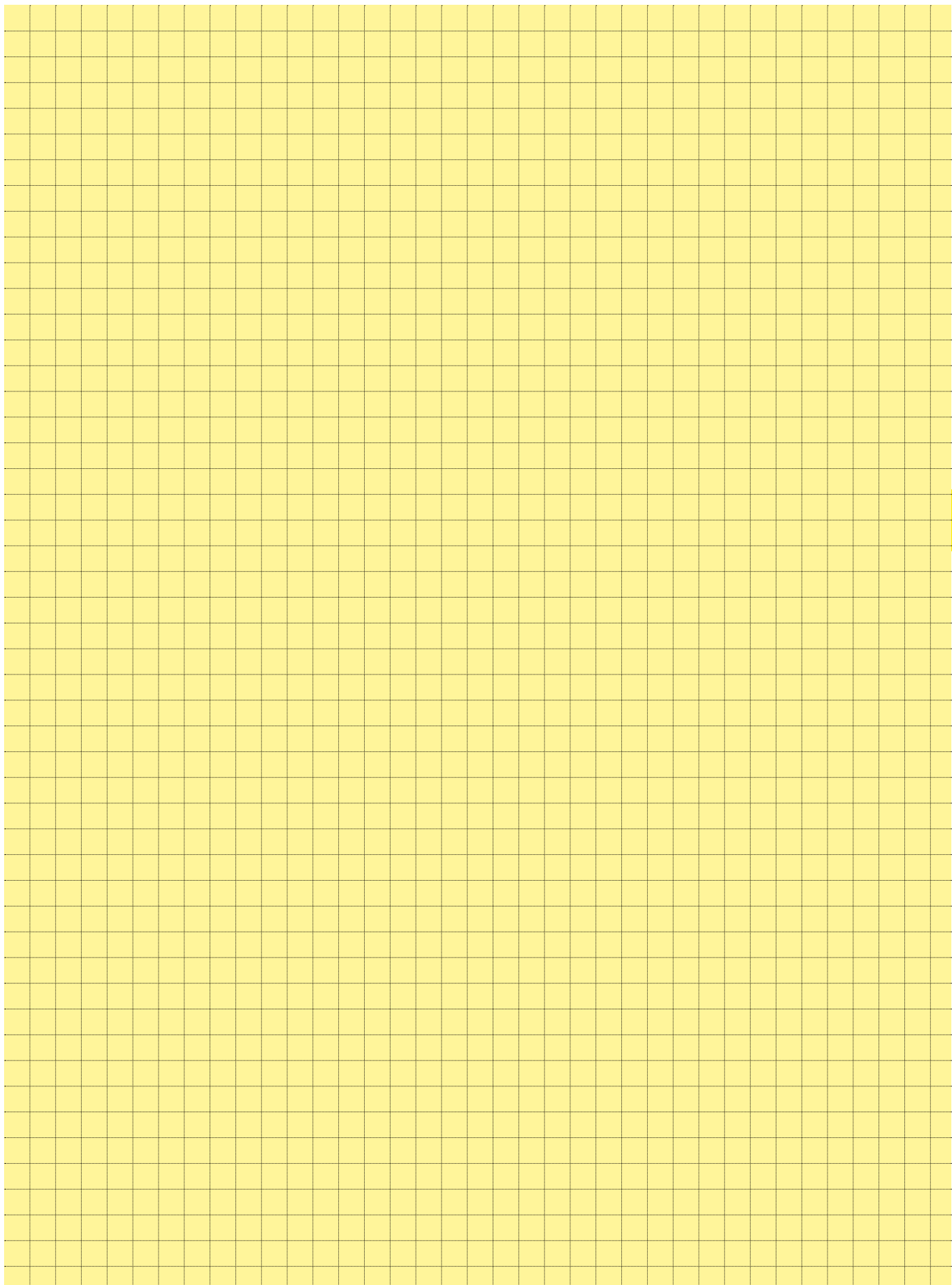

Connector hoods for spring or slide locking

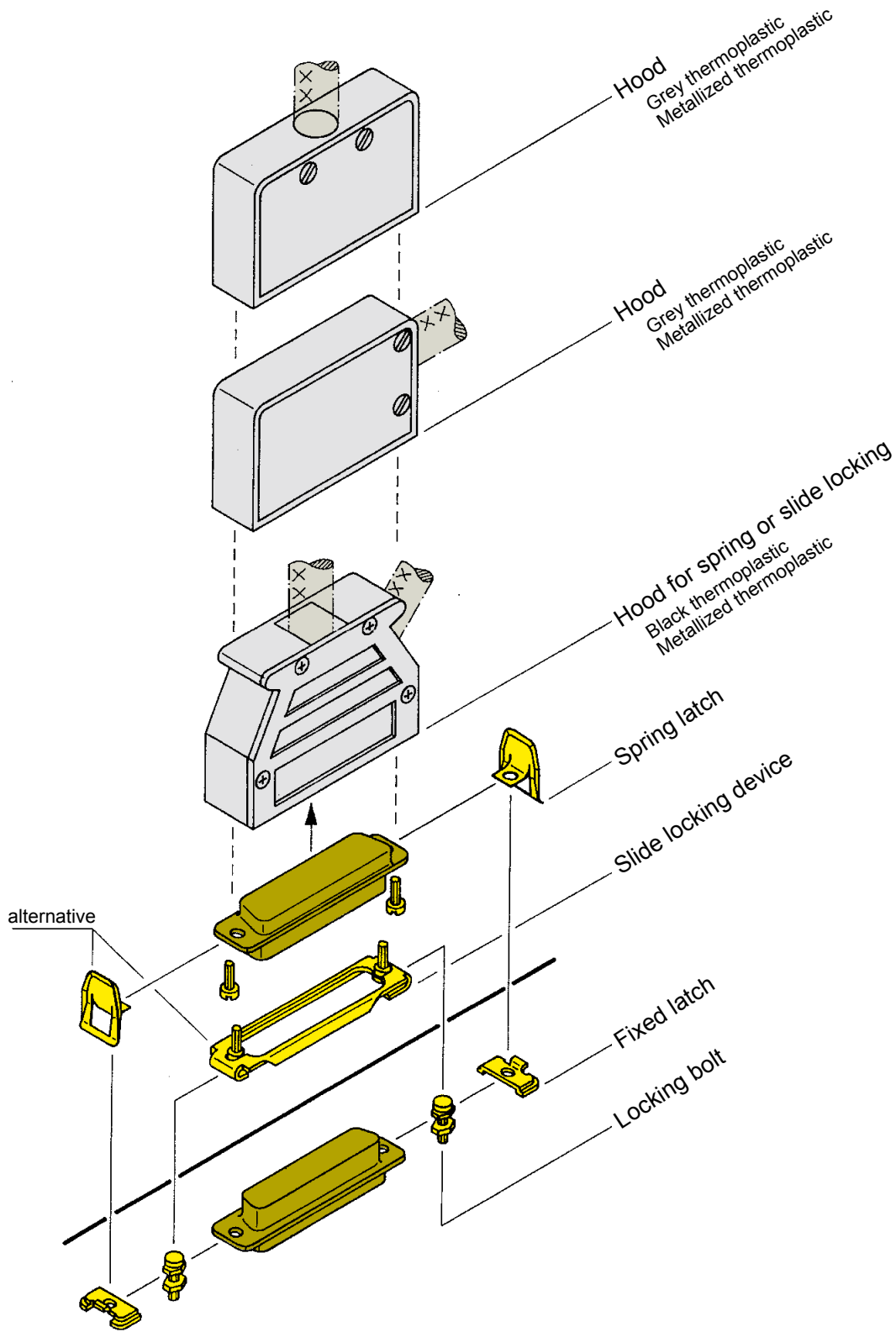

D-Sub - H

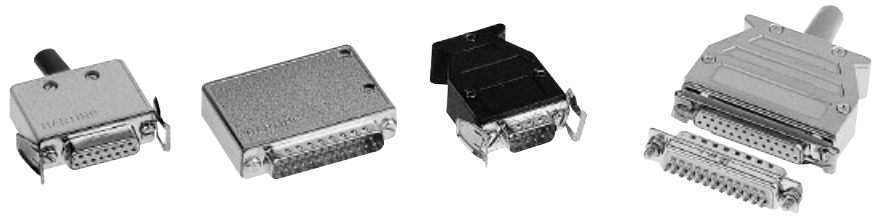

Thermoplastic top and side entry hoods for spring or slide locking

Identification No. of contacts Part No. Drawing Dimensions in mm

Top entry hood

9
15
25
37
50

Thermoplastic grey²⁾
09 67 009 0411
09 67 015 0411
09 67 025 0411
09 67 037 0411
09 67 050 0411

Thermoplastic metallized³⁾
09 67 009 0413
09 67 015 0413
09 67 025 0413
09 67 037 0413
09 67 050 0413

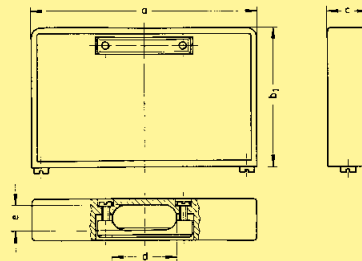

9-37 way for packaging density of 3 TE (15.24 mm)

	a	b ₁	b ₂	c	d	e	
						min.	max.
9	31.0	23	28	12.8	10	5.75	9.0
15	39.4	28	28	12.8	10	5.75	9.0
25	53.3	34	34	12.8	14	5.75	9.0
37	69.7	43	43	12.8	20	5.75	9.0
50	67.1	41	41	15.8	20	5.75	11.6

Side entry hood

9
15
25
37
50

Thermoplastic grey²⁾
09 67 009 0511
09 67 015 0511
09 67 025 0511
09 67 037 0511
09 67 050 0511

Thermoplastic metallized³⁾
09 67 009 0513
09 67 015 0513
09 67 025 0513
09 67 037 0513
09 67 050 0513

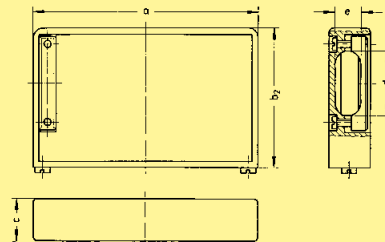

9-37 way for packaging density of 3 TE (15.24 mm)

Top and side entry hood¹⁾

9
15
25
37
50

Thermoplastic black⁴⁾
09 67 009 0452
09 67 015 0452
09 67 025 0452
09 67 037 0452
09 67 050 0452

Thermoplastic metallized⁴⁾
09 67 009 0453
09 67 015 0453
09 67 025 0453
09 67 037 0453
09 67 050 0453

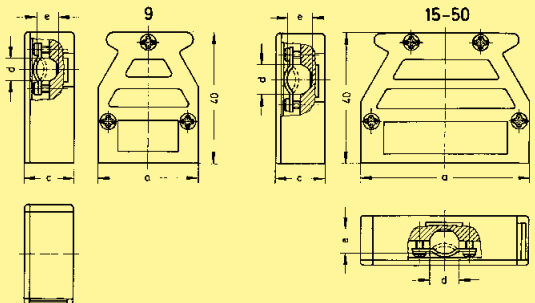

	a	c	d	e	
				min.	max.
9	31.0	15.4	7	1.7	7.5
15	39.4	15.4	7	1.7	8.0
25	53.2	15.4	9	1.5	8.0
37	69.5	15.4	9	1.5	8.0
50	67.0	17.9	9	1.5	8.0

¹⁾ 9 poles is only side entry

²⁾ Operating temperature: -55 °C ... +120 °C
³⁾ Operating temperature: -35 °C ... +60 °C
⁴⁾ Operating temperature: -20 °C ... +90 °C

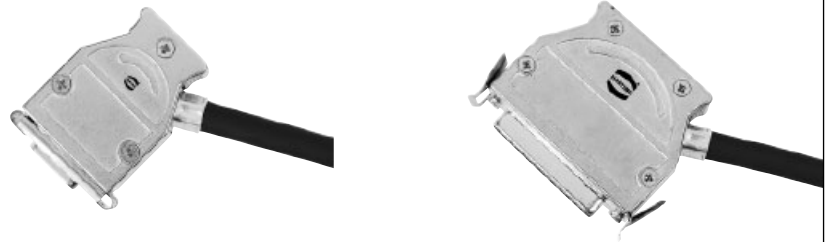

Full metal top and side entry hoods for spring or slide locking

Identification No. of contacts Part No. Drawing Dimensions in mm

Top/side entry hood with spring/slide locking

9 61 03 001 0022¹⁾
 15 61 03 001 0011²⁾
 25 61 03 001 0012²⁾
 37 61 03 001 0021²⁾
 50 61 03 001 0020²⁾

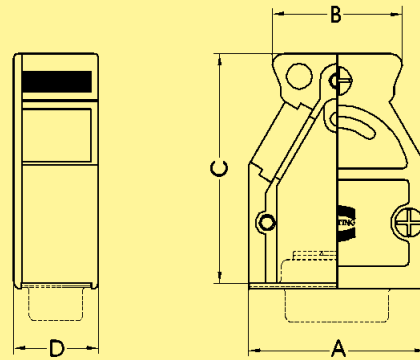

No. of contacts	No. of cable entries	A	B	C	D
9	2	31.0	22.6	40.0	14.8
15	3	39.0	30.6	40.0	14.8
25	3	53.0	42.6	40.0	14.8
37	3	69.5	59.2	40.0	14.8
50	3	67.0	55.0	40.0	17.6

D-Sub - H

¹⁾ Part No. contains one blanking piece
²⁾ Part No. contains two blanking pieces

Accessories for spring or slide locking hoods

Identification	No. of contacts	Part No.	Drawing	Dimensions in mm																														
Spring latch	9-50	corrosion resistant steel 09 67 000 9907 ¹⁾																																
Fixed latch ²⁾	9-37 50	corrosion resistant steel 09 67 001 9971 ¹⁾ 09 67 001 9972 ¹⁾																																
Slide locking device	9 15 25 37 50	corrosion resistant steel 09 67 000 9914 09 67 000 9915 09 67 000 9916 09 67 000 9917 09 67 000 9918	<table border="1"> <thead> <tr> <th></th> <th>a</th> <th>b</th> <th>c</th> <th>d</th> </tr> </thead> <tbody> <tr> <td>9</td> <td>35.0</td> <td>25.0</td> <td>11.7</td> <td>8.6</td> </tr> <tr> <td>15</td> <td>43.3</td> <td>33.3</td> <td>11.5</td> <td>8.6</td> </tr> <tr> <td>25</td> <td>57.0</td> <td>47.0</td> <td>11.7</td> <td>8.6</td> </tr> <tr> <td>37</td> <td>74.3</td> <td>63.5</td> <td>11.7</td> <td>8.6</td> </tr> <tr> <td>50</td> <td>72.0</td> <td>61.1</td> <td>14.7</td> <td>11.2</td> </tr> </tbody> </table>		a	b	c	d	9	35.0	25.0	11.7	8.6	15	43.3	33.3	11.5	8.6	25	57.0	47.0	11.7	8.6	37	74.3	63.5	11.7	8.6	50	72.0	61.1	14.7	11.2	
	a	b	c	d																														
9	35.0	25.0	11.7	8.6																														
15	43.3	33.3	11.5	8.6																														
25	57.0	47.0	11.7	8.6																														
37	74.3	63.5	11.7	8.6																														
50	72.0	61.1	14.7	11.2																														
Locking bolt	9-50	tinned 09 67 001 9973 ¹⁾																																

¹⁾ Order 2 for each connector

²⁾ Screws are not supplied with a fixed latch

Coding system

Example of application

Cable side:
female coding system
with 9 pole female cable connector
and InduCom hood.

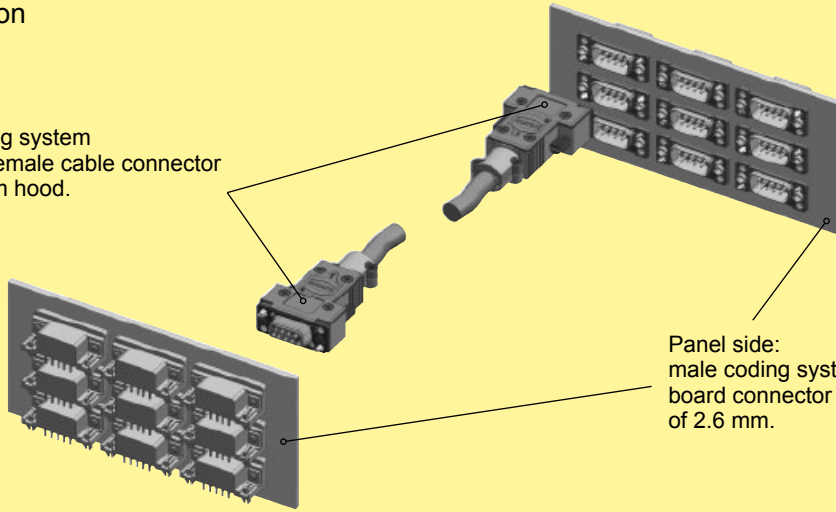

Panel side:
male coding system with 9 pole male
board connector and a board thickness
of 2.6 mm.

Exploded view panel side

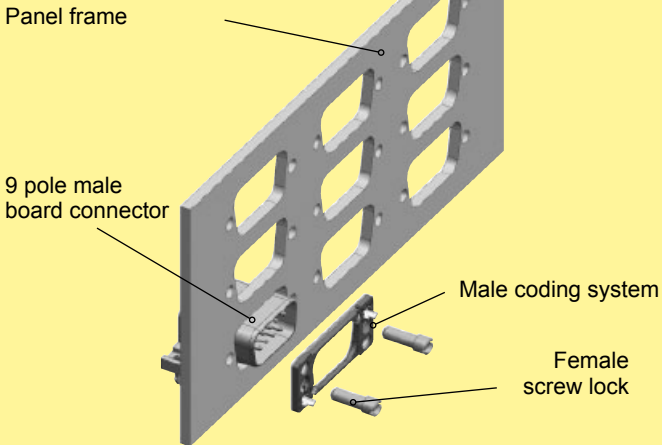

Exploded view cable side

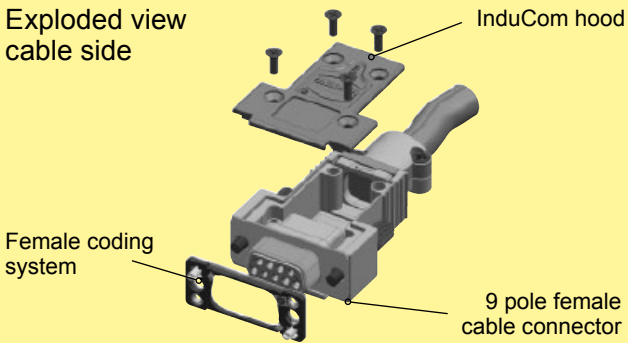

Coding key details



Standard coding combination

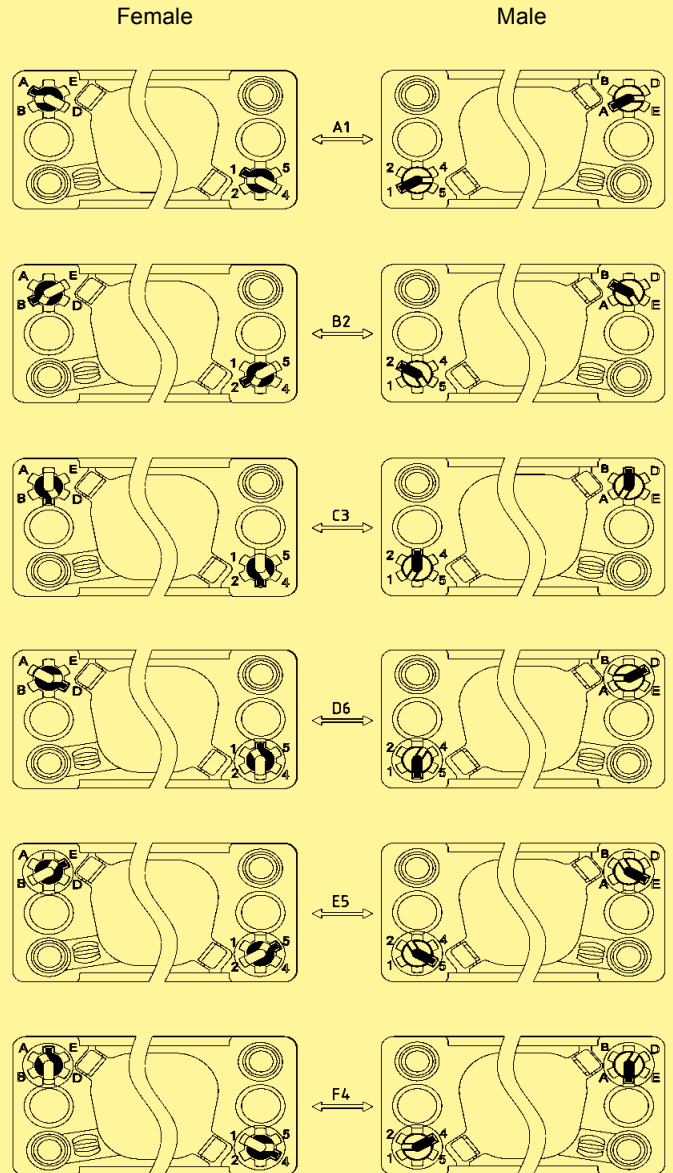

D-Sub - H

Accessories – coding system

Identification	Part No.	Panel thickness	Dimensions in mm																																				
Coding¹⁾																																							
Female	09 67 002 9121 xx 1	2.40 - 2.60 mm ³⁾																																					
	09 67 002 9121 xx 2	2.00 - 2.40 mm																																					
	09 67 002 9121 xx 3	1.20 - 2.00 mm																																					
	09 67 002 9121 xx 4	0.80 - 1.20 mm																																					
Male	09 67 002 9122 xx 1	2.40 - 2.60 mm ³⁾																																					
	09 67 002 9122 xx 2	2.00 - 2.40 mm																																					
	09 67 002 9122 xx 3	1.20 - 2.00 mm																																					
	09 67 002 9122 xx 4	0.80 - 1.20 mm																																					
Insert digits for coding configuration, e. g. "C3"		36 coding configurations ²⁾	<table border="1"> <tr> <td>A1</td> <td>B1</td> <td>C1</td> <td>D1</td> <td>E1</td> <td>F1</td> </tr> <tr> <td>A2</td> <td>B2</td> <td>C2</td> <td>D2</td> <td>E2</td> <td>F2</td> </tr> <tr> <td>A3</td> <td>B3</td> <td>C3</td> <td>D3</td> <td>E3</td> <td>F3</td> </tr> <tr> <td>A4</td> <td>B4</td> <td>C4</td> <td>D4</td> <td>E4</td> <td>F4</td> </tr> <tr> <td>A5</td> <td>B5</td> <td>C5</td> <td>D5</td> <td>E5</td> <td>F5</td> </tr> <tr> <td>A6</td> <td>B6</td> <td>C6</td> <td>D6</td> <td>E6</td> <td>F6</td> </tr> </table>	A1	B1	C1	D1	E1	F1	A2	B2	C2	D2	E2	F2	A3	B3	C3	D3	E3	F3	A4	B4	C4	D4	E4	F4	A5	B5	C5	D5	E5	F5	A6	B6	C6	D6	E6	F6
A1	B1	C1	D1	E1	F1																																		
A2	B2	C2	D2	E2	F2																																		
A3	B3	C3	D3	E3	F3																																		
A4	B4	C4	D4	E4	F4																																		
A5	B5	C5	D5	E5	F5																																		
A6	B6	C6	D6	E6	F6																																		
Female screw lock																																							
<table border="1"> <thead> <tr> <th colspan="2">Thread</th> </tr> <tr> <th>inner</th> <th>outer</th> </tr> </thead> <tbody> <tr> <td>4 - 40 UNC</td> <td>4 - 40 UNC</td> </tr> <tr> <td>4 - 40 UNC</td> <td>M3</td> </tr> <tr> <td>M3</td> <td>4 - 40 UNC</td> </tr> <tr> <td>M3</td> <td>M3</td> </tr> </tbody> </table>	Thread		inner	outer	4 - 40 UNC	4 - 40 UNC	4 - 40 UNC	M3	M3	4 - 40 UNC	M3	M3	<table border="1"> <tbody> <tr> <td>09 67 002 9123³⁾</td> <td rowspan="4">2.00 - 2.60 mm</td> </tr> <tr> <td>09 67 002 9124</td> </tr> <tr> <td>09 67 002 9125</td> </tr> <tr> <td>09 67 002 9126</td> </tr> <tr> <td>09 67 002 9129</td> <td rowspan="4">1.20 - 2.00 mm</td> </tr> <tr> <td>09 67 002 9130</td> </tr> <tr> <td>09 67 002 9131</td> </tr> <tr> <td>09 67 002 9132</td> </tr> <tr> <td>09 67 002 9133</td> <td rowspan="4">0.80 - 1.20 mm</td> </tr> <tr> <td>09 67 002 9134</td> </tr> <tr> <td>09 67 002 9135</td> </tr> <tr> <td>09 67 002 9136</td> </tr> </tbody> </table>	09 67 002 9123 ³⁾	2.00 - 2.60 mm	09 67 002 9124	09 67 002 9125	09 67 002 9126	09 67 002 9129	1.20 - 2.00 mm	09 67 002 9130	09 67 002 9131	09 67 002 9132	09 67 002 9133	0.80 - 1.20 mm	09 67 002 9134	09 67 002 9135	09 67 002 9136											
Thread																																							
inner	outer																																						
4 - 40 UNC	4 - 40 UNC																																						
4 - 40 UNC	M3																																						
M3	4 - 40 UNC																																						
M3	M3																																						
09 67 002 9123 ³⁾	2.00 - 2.60 mm																																						
09 67 002 9124																																							
09 67 002 9125																																							
09 67 002 9126																																							
09 67 002 9129	1.20 - 2.00 mm																																						
09 67 002 9130																																							
09 67 002 9131																																							
09 67 002 9132																																							
09 67 002 9133	0.80 - 1.20 mm																																						
09 67 002 9134																																							
09 67 002 9135																																							
09 67 002 9136																																							
9 pole top entry hood for coding																																							
<p>Please insert digit for screw option</p> <p>Hexagonal screw, thread M3 with captive washer ▶ 1</p> <p>Hexagonal screw, thread 4-40 UNC with captive washer ▶ 2</p>	61 03 001 . 010 123																																						

1) MOQ = 50 pieces
 2) Stock items (standard versions) in bold type
 3) Standard versions

Accessories for full metal hoods

Identification	Part No.		Drawing	Dimensions in mm																																																								
Crimp flange	Hoods for 9-37 pole D-Sub	Hoods for 50 pole D-Sub	<table border="1"> <thead> <tr> <th>D1</th> <th>D2</th> </tr> </thead> <tbody> <tr><td>3.0</td><td>4.0</td></tr> <tr><td>3.5</td><td>4.5</td></tr> <tr><td>4.0</td><td>5.0</td></tr> <tr><td>4.5</td><td>5.5</td></tr> <tr><td>5.0</td><td>6.0</td></tr> <tr><td>5.5</td><td>6.5</td></tr> <tr><td>6.0</td><td>7.0</td></tr> <tr><td>6.5</td><td>7.5</td></tr> <tr><td>7.0</td><td>8.0</td></tr> <tr><td>7.5</td><td>8.5</td></tr> <tr><td>8.0</td><td>9.0</td></tr> <tr><td>8.5</td><td>9.5</td></tr> <tr><td>9.0</td><td>10.0</td></tr> </tbody> </table>	D1	D2	3.0	4.0	3.5	4.5	4.0	5.0	4.5	5.5	5.0	6.0	5.5	6.5	6.0	7.0	6.5	7.5	7.0	8.0	7.5	8.5	8.0	9.0	8.5	9.5	9.0	10.0	<table border="1"> <thead> <tr> <th>D1</th> <th>D2</th> </tr> </thead> <tbody> <tr><td>3.0</td><td>4.0</td></tr> <tr><td>3.5</td><td>4.5</td></tr> <tr><td>4.0</td><td>5.0</td></tr> <tr><td>4.5</td><td>5.5</td></tr> <tr><td>5.0</td><td>6.0</td></tr> <tr><td>5.5</td><td>6.5</td></tr> <tr><td>6.0</td><td>7.0</td></tr> <tr><td>6.5</td><td>7.5</td></tr> <tr><td>7.0</td><td>8.0</td></tr> <tr><td>7.5</td><td>8.5</td></tr> <tr><td>8.0</td><td>9.0</td></tr> <tr><td>8.5</td><td>9.5</td></tr> <tr><td>9.0</td><td>10.0</td></tr> </tbody> </table>	D1	D2	3.0	4.0	3.5	4.5	4.0	5.0	4.5	5.5	5.0	6.0	5.5	6.5	6.0	7.0	6.5	7.5	7.0	8.0	7.5	8.5	8.0	9.0	8.5	9.5	9.0	10.0
	D1	D2																																																										
	3.0	4.0																																																										
	3.5	4.5																																																										
	4.0	5.0																																																										
	4.5	5.5																																																										
	5.0	6.0																																																										
	5.5	6.5																																																										
	6.0	7.0																																																										
	6.5	7.5																																																										
	7.0	8.0																																																										
	7.5	8.5																																																										
	8.0	9.0																																																										
	8.5	9.5																																																										
	9.0	10.0																																																										
D1	D2																																																											
3.0	4.0																																																											
3.5	4.5																																																											
4.0	5.0																																																											
4.5	5.5																																																											
5.0	6.0																																																											
5.5	6.5																																																											
6.0	7.0																																																											
6.5	7.5																																																											
7.0	8.0																																																											
7.5	8.5																																																											
8.0	9.0																																																											
8.5	9.5																																																											
9.0	10.0																																																											
Crimp ferrule	61 03 000 0045 61 03 000 0046 61 03 000 0047 61 03 000 0048 61 03 000 0049 61 03 000 0050 61 03 000 0051 61 03 000 0052 61 03 000 0053 61 03 000 0054 61 03 000 0055 61 03 000 0056 61 03 000 0057 61 03 000 0058 61 03 000 0142 61 03 000 0059 61 03 000 0127 61 03 000 0060 61 03 000 0061		<table border="1"> <thead> <tr> <th>D3</th> <th>D4</th> </tr> </thead> <tbody> <tr><td>5.0</td><td>6.0</td></tr> <tr><td>5.5</td><td>6.5</td></tr> <tr><td>6.0</td><td>7.0</td></tr> <tr><td>6.5</td><td>7.5</td></tr> <tr><td>7.0</td><td>8.0</td></tr> <tr><td>7.5</td><td>8.5</td></tr> <tr><td>8.0</td><td>9.0</td></tr> <tr><td>8.5</td><td>9.5</td></tr> <tr><td>9.0</td><td>10.0</td></tr> <tr><td>9.5</td><td>10.5</td></tr> <tr><td>10.0</td><td>11.0</td></tr> <tr><td>10.5</td><td>11.5</td></tr> <tr><td>11.0</td><td>12.0</td></tr> <tr><td>11.5</td><td>12.5</td></tr> <tr><td>12.0</td><td>13.0</td></tr> <tr><td>12.5</td><td>13.5</td></tr> <tr><td>13.0</td><td>14.0</td></tr> <tr><td>13.7</td><td>15.0</td></tr> <tr><td>14.0</td><td>15.0</td></tr> </tbody> </table>	D3	D4	5.0	6.0	5.5	6.5	6.0	7.0	6.5	7.5	7.0	8.0	7.5	8.5	8.0	9.0	8.5	9.5	9.0	10.0	9.5	10.5	10.0	11.0	10.5	11.5	11.0	12.0	11.5	12.5	12.0	13.0	12.5	13.5	13.0	14.0	13.7	15.0	14.0	15.0																	
	D3	D4																																																										
	5.0	6.0																																																										
	5.5	6.5																																																										
	6.0	7.0																																																										
	6.5	7.5																																																										
	7.0	8.0																																																										
	7.5	8.5																																																										
	8.0	9.0																																																										
	8.5	9.5																																																										
	9.0	10.0																																																										
	9.5	10.5																																																										
	10.0	11.0																																																										
	10.5	11.5																																																										
	11.0	12.0																																																										
	11.5	12.5																																																										
	12.0	13.0																																																										
	12.5	13.5																																																										
	13.0	14.0																																																										
	13.7	15.0																																																										
14.0	15.0																																																											
Cable clamp	cable-Ø appr. 5- 7 mm	61 03 000 0141																																																										
	cable-Ø appr. 7-10 mm	61 03 000 0044																																																										
	cable-Ø appr. 9-12 mm	61 03 000 0143																																																										
	cable-Ø appr. 11-14 mm	61 03 000 0145																																																										
Blanking piece for hoods	61 03 000 0042	61 03 000 0041																																																										
Hexagonal screw	thread 4-40 UNC x 17.5-8.8 with captive washer	09 67 002 9020																																																										
	thread M3 x 17.5-8.8 with captive washer	09 67 002 9019																																																										
Knurled screw	thread 4-40 UNC	09 67 002 9018																																																										
	thread M3	09 67 002 9017																																																										

D-Sub - H

Crimp flange termination instruction

1. Strip the cable sheath to the correct length (approx. 35 to 40 mm, depending on interface type).
2. Place the crimp ferrule over the cable sheath. Bend the outer screen backwards over the cable sheath. Cut screen approx. 2 mm from the end of the cable sheath.
3. Place the crimp flange over the wires covered by the remaining foil shield. Push and twist the crimp flange under the outer screen and cable sheath until the end of the cable sheath touches the crimp flange. HARTING has developed a special tool for optimised installation of the shielding over the crimp flange, part number 61 03 600 0017.
4. Move the crimp ferrule back onto the crimp flange and crimp the two parts together with the special service crimp tool part number 61 03 600 0020. For an optimised crimp process the tool should be positioned as close as possible to the crimp flange shoulder.
5. Cut off the internal screen foil and push the crimp flange inside the metal hood.

HARTING offers to test and define the best crimp flange and ferrule combination for customer specific cables.



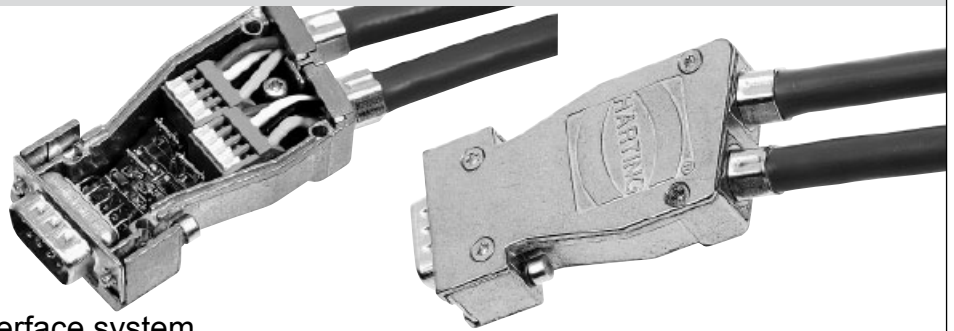

InduCom 9 – Industrial bus interface system

Identification

Part No.

General information

MVB Interface

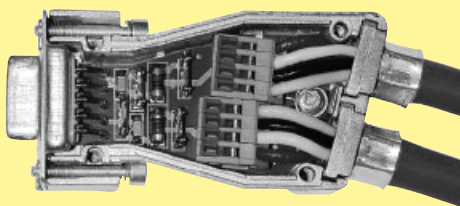

66 63 009 5013

MVB backbone interface set

The Multifunctional Vehicle Bus (MVB) backbone interface is specially designed for communication cables in Train Control Networks (TCN). With this interface it is possible to realise a T-bus structure with MVB-cable with which you can disconnect the bus interface from the control unit without any interruption of the complete bus communication. On the PCB you will have load resistors and test capacitors which can be activated with solder bridges. The wires are terminated with the proven vibration resistant cage clamp technology.*

Components of the MVB interface set:

- 1 metal housing with 2 cable entries
- 2 hexagonal screws with UNC 4-40 threads
- 1 PCB with 9 way D-Sub male connector and cage clamps
- 2 crimp flanges for the MVB cable
- 2 crimp ferrules for the MVB cable
- 1 blanking piece

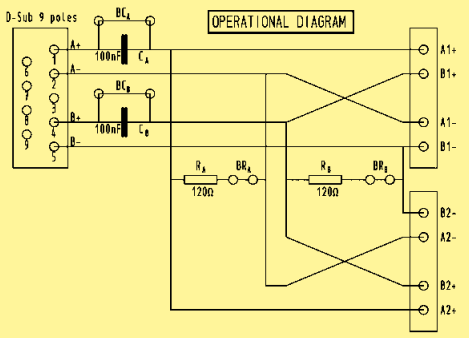

WTB Interface

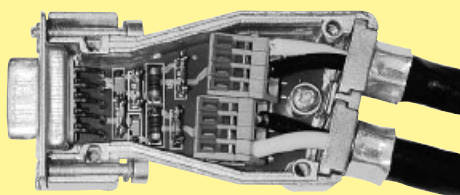

66 63 009 5014

WTB backbone interface set

The Wired Train Bus (WTB) backbone interface is specially designed for backbone cables in Train Control Networks (TCN). With this interface it is possible to realise a T-bus structure with WTB-cable with which you can disconnect the bus interface from the control unit without any interruption of the complete bus communication. On the PCB you will have load resistors and test capacitors which can be activated with solder bridges. The wires are terminated with the proven vibration resistant cage clamp technology.*

Components of the MVB interface set:

- 1 metal housing with 2 cable entries
- 2 hexagonal screws with UNC 4-40 threads
- 1 PCB with 9 way D-Sub male connector and cage clamps
- 2 crimp flanges for the WTB cable
- 2 crimp ferrules for the WTB cable
- 1 blanking piece

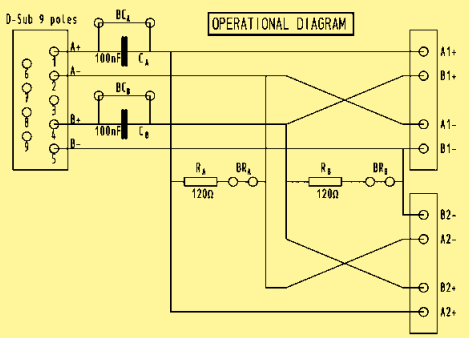

D-Sub - H

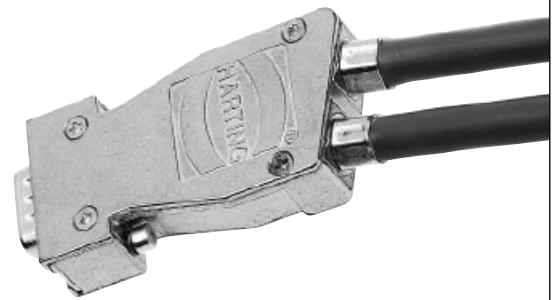
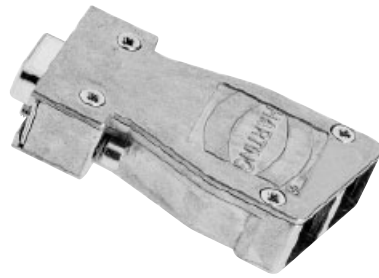

InduCom 9 – Industrial bus interface system

Identification

Part No.

General information

CAN Interface

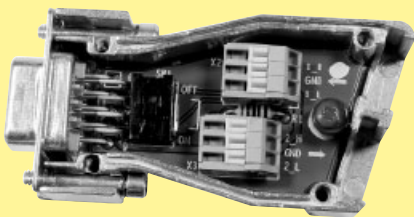

66 63 009 6016

The Controller Area Network (CAN)-Interface is specially designed for usage in trains. With this interface it is possible to realise a T-bus structure with which you can disconnect the bus interface from the control unit without any interruption of the complete bus communication. On the PCB you will have a load resistor which can be activated with the switch.*

Components of the interface set:

- 1 metal housing with 2 cable entries
- 2 hexagonal screws with UNC 4-40 threads
- 1 PCB with 9 way D-Sub female connector and 2 cage clamps
- 1 blanking piece
- 2 crimp flanges
- 2 crimp ferrules

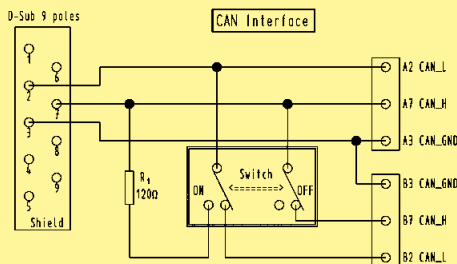

Profibus Interface

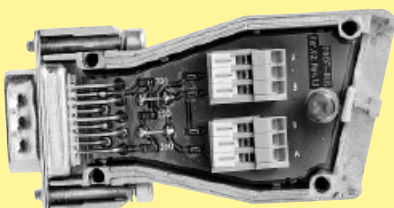

66 63 009 6004

The Profibus Interface is specially designed for usage in trains and in challenging engineering applications.

On the PCB you will have SMD parts which can be activated with solder bridges.

The wires are assembled with the proven vibration resistant cage clamp technology.*

Components of the interface set:

- 1 metal housing with 2 cable entries
- 2 hexagonal screws with UNC 4-40 threads
- 1 PCB with 9 way D-Sub female connector and 2 cage clamps
- 1 blanking piece

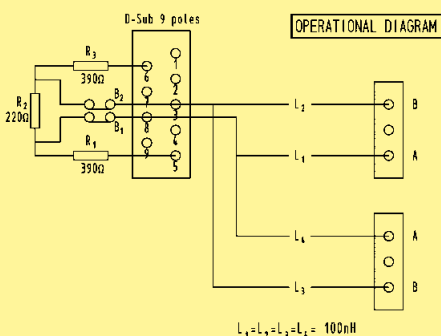

Further bus PCBs on request

* To check compatibility with cable types and manufacturers, please contact your local HARTING representative.

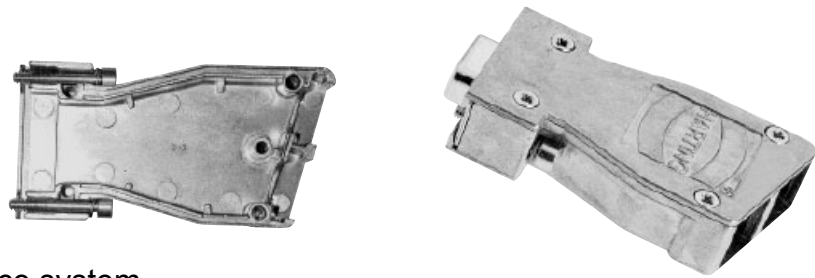

InduCom 9 – Industrial bus interface system

Identification

Part No.

General information

FIP Interface middle of the line

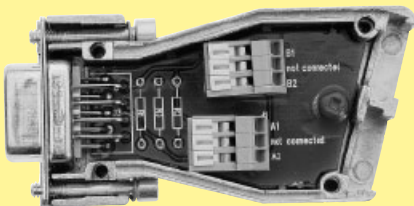

66 63 009 5017

The FIP (Factory Installation Protocol) Interface is specially designed for applications in trains. It is connected via the D-Sub. The wires are assembled with the proven vibration resistant cage clamp technology.*

Components of the interface set:

- 1 metal housing with 2 cable entries
- 2 hexagonal screws with UNC 4-40 threads
- 1 pcb with 9 way D-Sub female connector and cage clamps

FIP interface

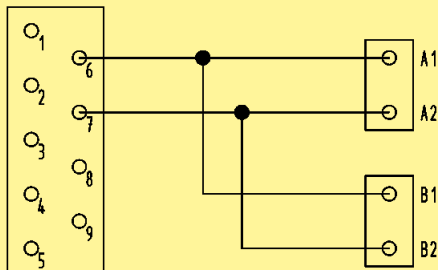

FIP Interface end of the line

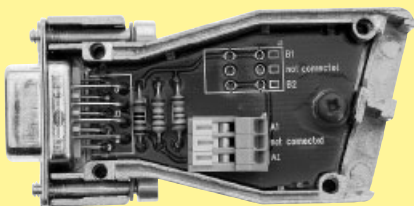

66 63 009 5018

The FIP (Factory Installation Protocol) Interface is specially designed for applications in trains. It is connected via the D-Sub. On the pcb you will have load resistors. The wires are assembled with the proven vibration resistant cage clamp technology.*

Components of the interface set:

- 1 metal housing with 2 cable entries
- 2 hexagonal screws with UNC 4-40 threads
- 1 pcb with 9 way D-Sub female connector and cage clamps
- 1 blanking piece

FIP interface

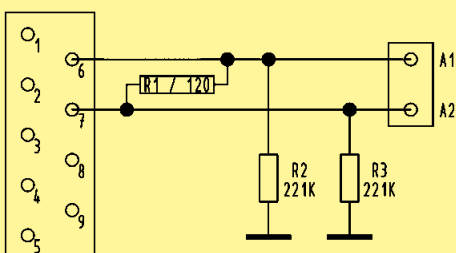

D-Sub - H

D-Sub – Accessories for subminiature D connectors

Page

Accessories

08.02

Accessories

Identification	No. of contacts	Part No.	Drawing	Dimensions in mm
Female screw locks without nut	9-50	09 67 000 9972 ¹⁾		
	9-50	09 67 000 9974 ¹⁾		
	Thread UNC/UNC Thread UNC/M3	9-50 9-50	09 67 001 9976 ¹⁾ 09 67 001 9974 ¹⁾	
Thread UNC/UNC Thread UNC/M3	9-50 9-50	09 67 001 9941 ¹⁾ 09 67 001 9954 ¹⁾		
for press-in connectors with grounding-pins or straight solder with grounding-clips.	9-50	09 66 000 9972 ¹⁾		
	9-50	09 66 000 9974 ¹⁾²⁾		
Thread UNC/UNC Thread UNC/M3	9-50 9-50	09 66 001 9957 ¹⁾		
with captive washer	9-50	09 67 001 9957 ¹⁾		
Thread UNC/UNC	9-50	09 67 001 9957 ¹⁾		

D-Sub - A

1) Order 2 for each connector
2) M3 inner thread available on request

Accessories

Identification	No. of contacts	Part No.	Drawing	Dimensions in mm
Female screw locks with nut Thread UNC/UNC Thread UNC/M3 Thread UNC/UNC	9-50 9-50 9-50	09 67 000 9922 ¹⁾ 09 67 000 9924 ¹⁾ 09 67 000 9973 ¹⁾		
Male screw locks for use without hood	9-37 50	09 67 001 9969 ¹⁾ 09 67 001 9970 ¹⁾		
Hex extender Thread 4-40 UNC Thread M3	9-50 9-50	09 67 001 9985 09 67 002 9120		
U-Clip with thread 4-40 UNC	9-50	09 67 001 9928 ¹⁾		
U-Clip with thread 4-40 UNC and screw-lock	9-50	09 67 002 9030 ¹⁾		

¹⁾ Order 2 for each connector

Accessories

Identification	No. of contacts	Part No.	Drawing	Dimensions in mm																														
Dust cap black thermoplastic for male connector	9	09 67 009 0611		<table border="1"> <thead> <tr> <th></th> <th>A</th> <th>B</th> </tr> </thead> <tbody> <tr> <td>9</td> <td>17.0</td> <td>22.40</td> </tr> <tr> <td>15</td> <td>25.3</td> <td>30.80</td> </tr> <tr> <td>25</td> <td>38.9</td> <td>44.40</td> </tr> <tr> <td>37</td> <td>55.4</td> <td>60.75</td> </tr> </tbody> </table>		A	B	9	17.0	22.40	15	25.3	30.80	25	38.9	44.40	37	55.4	60.75															
		A		B																														
	9	17.0		22.40																														
	15	25.3		30.80																														
	25	38.9		44.40																														
	37	55.4		60.75																														
	15	09 67 015 0611																																
	25	09 67 025 0611																																
37	09 67 037 0611																																	
9	09 67 009 0711		<table border="1"> <thead> <tr> <th></th> <th>A</th> <th>B</th> </tr> </thead> <tbody> <tr> <td>9</td> <td>16.0</td> <td>22.5</td> </tr> <tr> <td>15</td> <td>24.4</td> <td>31.0</td> </tr> <tr> <td>25</td> <td>37.8</td> <td>44.3</td> </tr> <tr> <td>37</td> <td>54.3</td> <td>60.8</td> </tr> </tbody> </table>		A	B	9	16.0	22.5	15	24.4	31.0	25	37.8	44.3	37	54.3	60.8																
	A		B																															
9	16.0		22.5																															
15	24.4		31.0																															
25	37.8	44.3																																
37	54.3	60.8																																
15	09 67 015 0711																																	
25	09 67 025 0711																																	
37	09 67 037 0711																																	
antistatic black thermoplastic for male connector	9	09 67 009 0612		<table border="1"> <thead> <tr> <th></th> <th>A</th> <th>B</th> <th>C</th> <th>D</th> </tr> </thead> <tbody> <tr> <td>9</td> <td>17.7</td> <td>21.8</td> <td>13.2</td> <td>9.1</td> </tr> <tr> <td>15</td> <td>26.0</td> <td>30.0</td> <td>13.2</td> <td>9.1</td> </tr> <tr> <td>25</td> <td>40.0</td> <td>44.2</td> <td>13.2</td> <td>9.1</td> </tr> <tr> <td>37</td> <td>56.4</td> <td>59.8</td> <td>13.2</td> <td>9.1</td> </tr> <tr> <td>50</td> <td>53.9</td> <td>57.8</td> <td>15.9</td> <td>11.7</td> </tr> </tbody> </table>		A	B	C	D	9	17.7	21.8	13.2	9.1	15	26.0	30.0	13.2	9.1	25	40.0	44.2	13.2	9.1	37	56.4	59.8	13.2	9.1	50	53.9	57.8	15.9	11.7
		A		B	C	D																												
	9	17.7		21.8	13.2	9.1																												
	15	26.0		30.0	13.2	9.1																												
	25	40.0		44.2	13.2	9.1																												
	37	56.4		59.8	13.2	9.1																												
	50	53.9		57.8	15.9	11.7																												
	15	09 67 015 0612																																
25	09 67 025 0612																																	
37	09 67 037 0612																																	
50	09 67 050 0612																																	
9	09 67 009 0712		<table border="1"> <thead> <tr> <th></th> <th>A</th> <th>B</th> <th>C</th> <th>D</th> </tr> </thead> <tbody> <tr> <td>9</td> <td>15.9</td> <td>20.0</td> <td>11.8</td> <td>7.8</td> </tr> <tr> <td>15</td> <td>24.4</td> <td>28.5</td> <td>11.8</td> <td>7.8</td> </tr> <tr> <td>25</td> <td>38.3</td> <td>42.3</td> <td>11.8</td> <td>7.8</td> </tr> <tr> <td>37</td> <td>54.7</td> <td>58.8</td> <td>11.8</td> <td>7.8</td> </tr> <tr> <td>50</td> <td>52.6</td> <td>56.2</td> <td>14.5</td> <td>10.5</td> </tr> </tbody> </table>		A	B	C	D	9	15.9	20.0	11.8	7.8	15	24.4	28.5	11.8	7.8	25	38.3	42.3	11.8	7.8	37	54.7	58.8	11.8	7.8	50	52.6	56.2	14.5	10.5	
	A		B	C	D																													
9	15.9		20.0	11.8	7.8																													
15	24.4		28.5	11.8	7.8																													
25	38.3		42.3	11.8	7.8																													
37	54.7	58.8	11.8	7.8																														
50	52.6	56.2	14.5	10.5																														
15	09 67 015 0712																																	
25	09 67 025 0712																																	
37	09 67 037 0712																																	
50	09 67 050 0712																																	
UL 94 V0 grey thermoplastic for male connector	9	09 67 009 0613		<table border="1"> <thead> <tr> <th></th> <th>A</th> <th>B</th> <th>C</th> <th>D</th> </tr> </thead> <tbody> <tr> <td>9</td> <td>17.7</td> <td>21.8</td> <td>13.2</td> <td>9.1</td> </tr> <tr> <td>15</td> <td>26.0</td> <td>30.0</td> <td>13.2</td> <td>9.1</td> </tr> <tr> <td>25</td> <td>40.0</td> <td>44.2</td> <td>13.2</td> <td>9.1</td> </tr> <tr> <td>37</td> <td>56.4</td> <td>59.8</td> <td>13.2</td> <td>9.1</td> </tr> <tr> <td>50</td> <td>53.9</td> <td>57.8</td> <td>15.9</td> <td>11.7</td> </tr> </tbody> </table>		A	B	C	D	9	17.7	21.8	13.2	9.1	15	26.0	30.0	13.2	9.1	25	40.0	44.2	13.2	9.1	37	56.4	59.8	13.2	9.1	50	53.9	57.8	15.9	11.7
		A		B	C	D																												
	9	17.7		21.8	13.2	9.1																												
	15	26.0		30.0	13.2	9.1																												
	25	40.0		44.2	13.2	9.1																												
	37	56.4		59.8	13.2	9.1																												
	50	53.9		57.8	15.9	11.7																												
	15	09 67 015 0613																																
25	09 67 025 0613																																	
37	09 67 037 0613																																	
50	09 67 050 0613																																	
9	09 67 009 0713		<table border="1"> <thead> <tr> <th></th> <th>A</th> <th>B</th> <th>C</th> <th>D</th> </tr> </thead> <tbody> <tr> <td>9</td> <td>15.9</td> <td>20.0</td> <td>11.8</td> <td>7.8</td> </tr> <tr> <td>15</td> <td>24.4</td> <td>28.5</td> <td>11.8</td> <td>7.8</td> </tr> <tr> <td>25</td> <td>38.3</td> <td>42.3</td> <td>11.8</td> <td>7.8</td> </tr> <tr> <td>37</td> <td>54.7</td> <td>58.8</td> <td>11.8</td> <td>7.8</td> </tr> <tr> <td>50</td> <td>52.6</td> <td>56.2</td> <td>14.5</td> <td>10.5</td> </tr> </tbody> </table>		A	B	C	D	9	15.9	20.0	11.8	7.8	15	24.4	28.5	11.8	7.8	25	38.3	42.3	11.8	7.8	37	54.7	58.8	11.8	7.8	50	52.6	56.2	14.5	10.5	
	A		B	C	D																													
9	15.9		20.0	11.8	7.8																													
15	24.4		28.5	11.8	7.8																													
25	38.3		42.3	11.8	7.8																													
37	54.7	58.8	11.8	7.8																														
50	52.6	56.2	14.5	10.5																														
15	09 67 015 0713																																	
25	09 67 025 0713																																	
37	09 67 037 0713																																	
50	09 67 050 0713																																	

Accessories

Identification	No. of contacts	Part No.	Drawing	Dimensions in mm																														
Dust cap metallized thermoplastic	for male connector	9		<table border="1"> <thead> <tr> <th></th> <th>A</th> <th>B</th> <th>C</th> <th>D</th> </tr> </thead> <tbody> <tr> <td>9</td> <td>17.7</td> <td>21.8</td> <td>13.2</td> <td>9.1</td> </tr> <tr> <td>15</td> <td>26.0</td> <td>30.0</td> <td>13.2</td> <td>9.1</td> </tr> <tr> <td>25</td> <td>40.0</td> <td>44.2</td> <td>13.2</td> <td>9.1</td> </tr> <tr> <td>37</td> <td>56.4</td> <td>59.8</td> <td>13.2</td> <td>9.1</td> </tr> <tr> <td>50</td> <td>53.9</td> <td>57.8</td> <td>15.9</td> <td>11.7</td> </tr> </tbody> </table>		A	B	C	D	9	17.7	21.8	13.2	9.1	15	26.0	30.0	13.2	9.1	25	40.0	44.2	13.2	9.1	37	56.4	59.8	13.2	9.1	50	53.9	57.8	15.9	11.7
					A	B	C	D																										
		9			17.7	21.8	13.2	9.1																										
		15			26.0	30.0	13.2	9.1																										
		25			40.0	44.2	13.2	9.1																										
	37	56.4			59.8	13.2	9.1																											
	50	53.9			57.8	15.9	11.7																											
	15	09 67 015 0614																																
	25	09 67 025 0614																																
	37	09 67 037 0614																																
50	09 67 050 0614																																	
for female connector	9	09 67 009 0714		<table border="1"> <thead> <tr> <th></th> <th>A</th> <th>B</th> <th>C</th> <th>D</th> </tr> </thead> <tbody> <tr> <td>9</td> <td>15.9</td> <td>20.0</td> <td>11.8</td> <td>7.8</td> </tr> <tr> <td>15</td> <td>24.4</td> <td>28.5</td> <td>11.8</td> <td>7.8</td> </tr> <tr> <td>25</td> <td>38.3</td> <td>42.3</td> <td>11.8</td> <td>7.8</td> </tr> <tr> <td>37</td> <td>54.7</td> <td>58.8</td> <td>11.8</td> <td>7.8</td> </tr> <tr> <td>50</td> <td>52.6</td> <td>56.2</td> <td>14.5</td> <td>10.5</td> </tr> </tbody> </table>		A	B	C	D	9	15.9	20.0	11.8	7.8	15	24.4	28.5	11.8	7.8	25	38.3	42.3	11.8	7.8	37	54.7	58.8	11.8	7.8	50	52.6	56.2	14.5	10.5
		A			B	C	D																											
	9	15.9			20.0	11.8	7.8																											
	15	24.4			28.5	11.8	7.8																											
	25	38.3			42.3	11.8	7.8																											
37	54.7	58.8			11.8	7.8																												
50	52.6	56.2			14.5	10.5																												
15	09 67 015 0714																																	
25	09 67 025 0714																																	
37	09 67 037 0714																																	
50	09 67 050 0714																																	
metallized thermoplastic with chain	for male connector	9		<table border="1"> <thead> <tr> <th></th> <th>A</th> <th>B</th> <th>C</th> <th>D</th> </tr> </thead> <tbody> <tr> <td>9</td> <td>17.5</td> <td>19.6</td> <td>11.1</td> <td>9.2</td> </tr> <tr> <td>15</td> <td>25.7</td> <td>27.8</td> <td>11.1</td> <td>9.2</td> </tr> <tr> <td>25</td> <td>39.6</td> <td>41.8</td> <td>11.1</td> <td>9.2</td> </tr> <tr> <td>37</td> <td>55.7</td> <td>57.4</td> <td>11.1</td> <td>9.2</td> </tr> <tr> <td>50</td> <td>53.4</td> <td>55.3</td> <td>13.8</td> <td>11.9</td> </tr> </tbody> </table>		A	B	C	D	9	17.5	19.6	11.1	9.2	15	25.7	27.8	11.1	9.2	25	39.6	41.8	11.1	9.2	37	55.7	57.4	11.1	9.2	50	53.4	55.3	13.8	11.9
					A	B	C	D																										
		9			17.5	19.6	11.1	9.2																										
		15			25.7	27.8	11.1	9.2																										
		25			39.6	41.8	11.1	9.2																										
	37	55.7			57.4	11.1	9.2																											
	50	53.4			55.3	13.8	11.9																											
	15	09 67 015 0615																																
	25	09 67 025 0615																																
	37	09 67 037 0615																																
50	09 67 050 0615																																	
for female connector	9	09 67 009 0715		<table border="1"> <thead> <tr> <th></th> <th>A</th> <th>B</th> <th>C</th> <th>D</th> </tr> </thead> <tbody> <tr> <td>9</td> <td>16.2</td> <td>18.0</td> <td>9.6</td> <td>7.8</td> </tr> <tr> <td>15</td> <td>24.6</td> <td>26.4</td> <td>9.6</td> <td>7.8</td> </tr> <tr> <td>25</td> <td>38.4</td> <td>40.2</td> <td>9.6</td> <td>7.8</td> </tr> <tr> <td>37</td> <td>54.4</td> <td>56.2</td> <td>9.6</td> <td>7.8</td> </tr> <tr> <td>50</td> <td>52.0</td> <td>53.7</td> <td>12.2</td> <td>10.4</td> </tr> </tbody> </table>		A	B	C	D	9	16.2	18.0	9.6	7.8	15	24.6	26.4	9.6	7.8	25	38.4	40.2	9.6	7.8	37	54.4	56.2	9.6	7.8	50	52.0	53.7	12.2	10.4
		A			B	C	D																											
	9	16.2			18.0	9.6	7.8																											
	15	24.6			26.4	9.6	7.8																											
	25	38.4			40.2	9.6	7.8																											
37	54.4	56.2			9.6	7.8																												
50	52.0	53.7			12.2	10.4																												
15	09 67 015 0715																																	
25	09 67 025 0715																																	
37	09 67 037 0715																																	
50	09 67 050 0715																																	

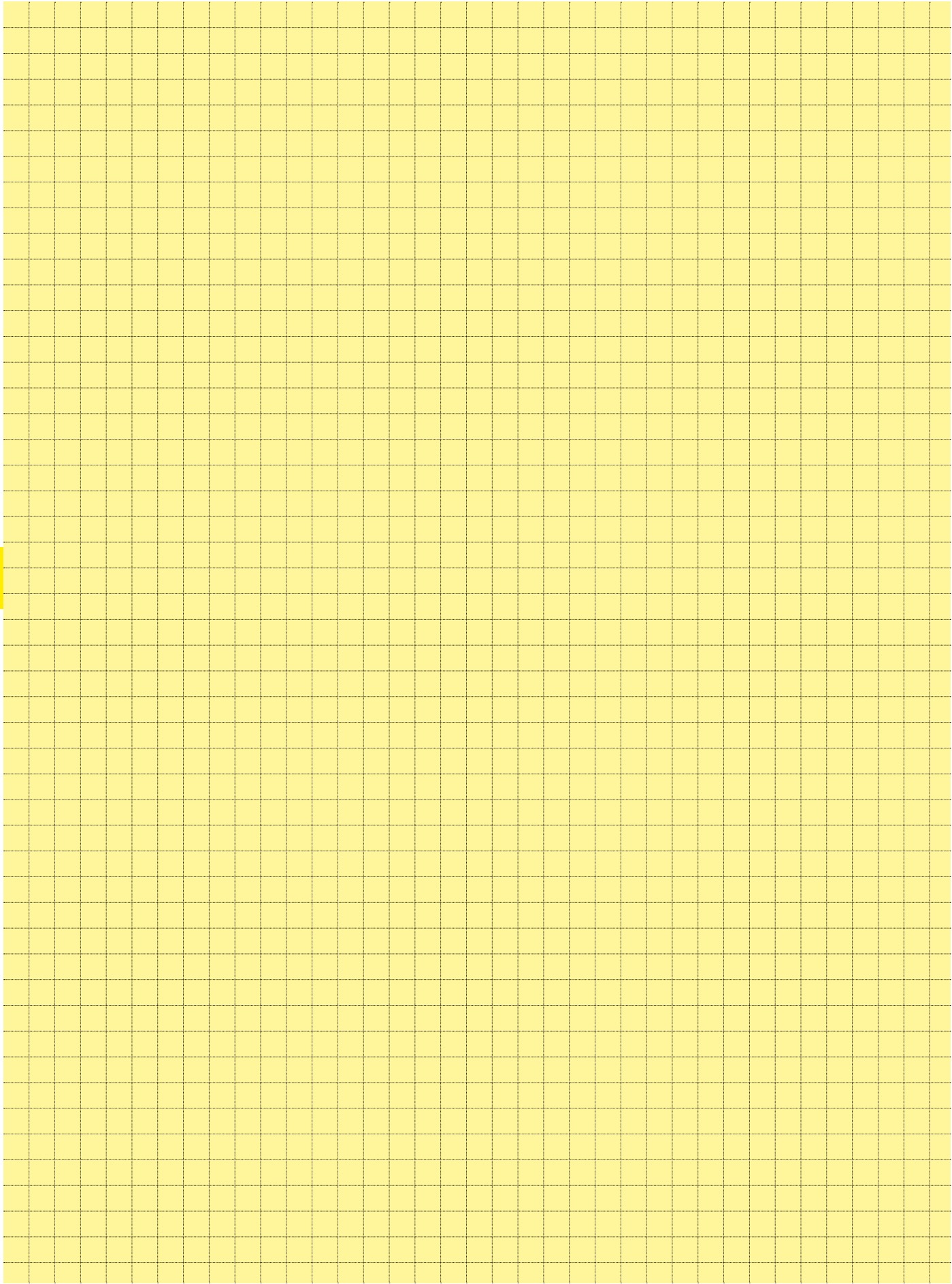

D-Sub - A

SEK – Insulation Displacement Connector system (IDC), 2.54 mm pitch

Page

General information **09.02**

Solder board connectors

Technical characteristics **09.04**

Male standard connectors **09.06**

Male standard connectors, kinked **09.10**

Male standard connectors with board lock **09.12**

Male low-profile connectors **09.14**

Accessories **09.16**

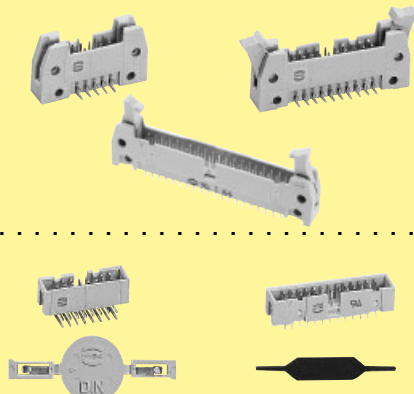

Wrap post connectors

Technical characteristics **09.17**

Male standard connectors **09.18**

Accessories **09.20**



Cable connectors

Technical characteristics for female connectors **09.21**

Female connectors **09.22**

Technical characteristics for pcb transition connectors, 2 rows **09.24**

Pcb transition connectors, 2 rows **09.25**

Technical characteristics for pcb transition connectors, 4 rows **09.26**

Pcb transition connectors, 4 rows **09.27**

Technical characteristics for DIP connectors **09.28**

DIP connectors **09.29**

Technical characteristics for DIN 41 612 connectors **09.30**

DIN 41 612 connectors **09.31**

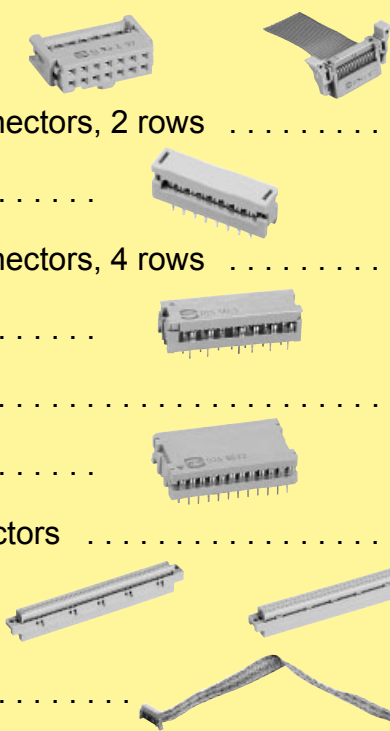

Cables and cable assemblies

see chapter 40

Declaration of conformity

This Declaration of Conformity is suitable to the European Standard EN 45 014, „General criteria for suppliers declaration of conformity“.
The basis for the criteria has been found in international documentation, particularly in ISO/IEC Guide 22, 1996, „Information on manufacturers declaration of conformity with standards or other technical specifications“.

We

HARTING KGaA
Marienwerder Str. 3
32339 Espelkamp

HARTING Electronics GmbH & Co KG
Marienwerder Str.3
32339 Espelkamp

declare under our own responsibility that the

Flat Cable Connector System

is in conformity with the following standard
IEC 60603-13

Connectors for frequencies below 3MHz for use with printed board-Part 13: Detail specification for two-part connectors with assessed quality, for printed boards, for basic grid of 2,54 mm (0,1in) with free connectors for non – accessible insulation displacement termination (ID)

This declaration of conformity refers to the series:

SEK

SEK



Our testing laboratory is accredited and monitored by the German Accreditation Body Technology/ (DATEch).
 Reg.-Nr. DAT-P-041/94-02

QUALITY SYSTEM



certified by DQS acc. to ISO 9001 - Reg.-Nr. 2204

Our quality system is certified and monitored by DQS in conformity with the standard DIN EN ISO 9001 : 2000.
 Cert.-Nr. 002204 QM

Espekkamp, 2004-11-18

Place and Date of publication

Dr. Georg Staperfeld
 Senior Manager of Corporate Technology Services

Espekkamp, 2004-11-18

Place and Date of publication

Dipl.-Ing. Hartmuth Schmidt
 Director Global Product Management HARTING Electronics GmbH & Co KG

The HARTING Insulation Displacement Connector system

Economic and reliable connections

The flat cable and connector can be preassembled and used as a component with predetermined functional characteristics.

The HARTING insulation displacement contacts pierce the insulation on the flat cable to provide a durable gastight connection with the wire.

The HARTING insulation displacement technique constitutes the ideal solution to your wiring problems.

For "non standard applications" we can manufacture designs to match your requirements.

Please discuss requirements with us.

HARTING SEK connectors incorporate the latest design features and provide the assurance of high quality and reliability with economy.

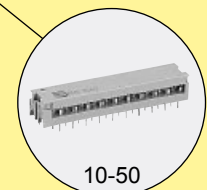
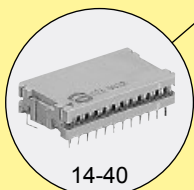
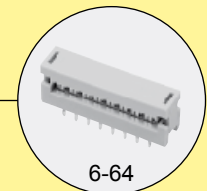
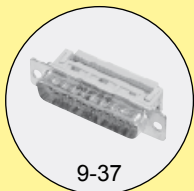
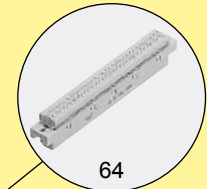
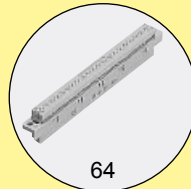
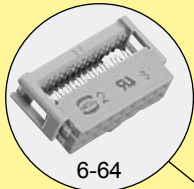

Cable assemblies

- HARTING can supply cable assemblies to customer specifications.
- A wide range of connector types available with various contact arrangements constitute the ideal solution to your wiring problems.
- Cables of all types in economic reel lengths are available.

Quality

- Cables professionally assembled on HARTING work stations ensure reliable connections.
- Finished harnesses are subject to 100% quality checks on a HARTING test device.
- Insulation test.
- Contact resistance test.

Economy

- The tested assembly of connectors and flat cables from one manufacturer guarantees a high degree of economy and reliability.
- Investment for work stations and test devices are not required.
- Stocks of piece parts are reduced.

Number of contacts 6, 10, 14, 16, 20, 24, 26, 30, 34, 40, 50, 60, 64

Contact arrangement straight, angled

Contact length 2.9 mm, 4.5 mm

Approvals IEC 60603-13
DIN EN 60603-13
D 2632
BT 224
NFC 93-428 (HE 10)
UL recognized: E102079



Pitch 2.54 mm [0.100"]

Working current 1 A

Working voltage 500 V
for pollution degree 1

Test voltage $U_{r.m.s.}$ 1 kV

Contact resistance $\leq 20 \text{ m}\Omega$
Insulation resistance $\geq 10^9 \Omega$

Temperature range $-55 \text{ }^\circ\text{C} \dots +125 \text{ }^\circ\text{C}$
The maximum temperature includes heating of contacts and ambient temperature

Terminations For pcb hole $\varnothing 1 \pm 0.1 \text{ mm}$
DIN IEC 52 141
Diagonal: 0.79 mm

Materials Moulding Thermoplastic resin (PBT)
UL 94-V0

Contact surface Contact zone plated according to performance level¹⁾

Current carrying capacity

The current carrying capacity is limited by maximum temperature of materials for inserts and contacts including terminals. The current capacity-curve is valid for continuous, not interrupted current-loaded contacts of connectors when simultaneous power on all contacts is given, without exceeding the maximum temperature.

Control and test procedures according to DIN IEC 60 512.

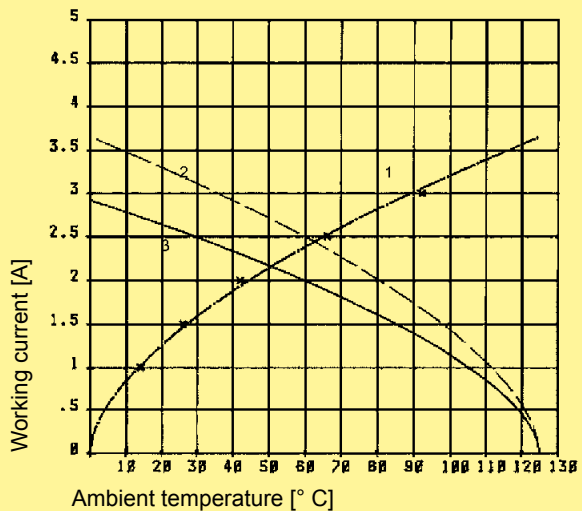

Example: 50 way connector

- ① Temperature rise
- ② Derating
- ③ Derating curve at $I_{max} \times 0.8$ (IEC 60 512-2)

Insertion and withdrawal forces

Number of contacts	Maximum force [N]	
	Performance level 1 and 2	Performance level 3
6	12	18
10	20	30
14	28	42
16	32	48
20	40	60
24	48	72
26	52	78
30	60	90
34	68	102
40	80	120
50	100	150
60	120	180
64	128	192

¹⁾ Performance level 3 as per IEC 60603-13, ≥ 50 mating cycles, no gas test
Performance level 2 as per IEC 60603-13, ≥ 250 mating cycles, 4 days gas test
S4, plating = $0.76 \mu\text{m}$ (30 μinch) Au or PdNi equivalent

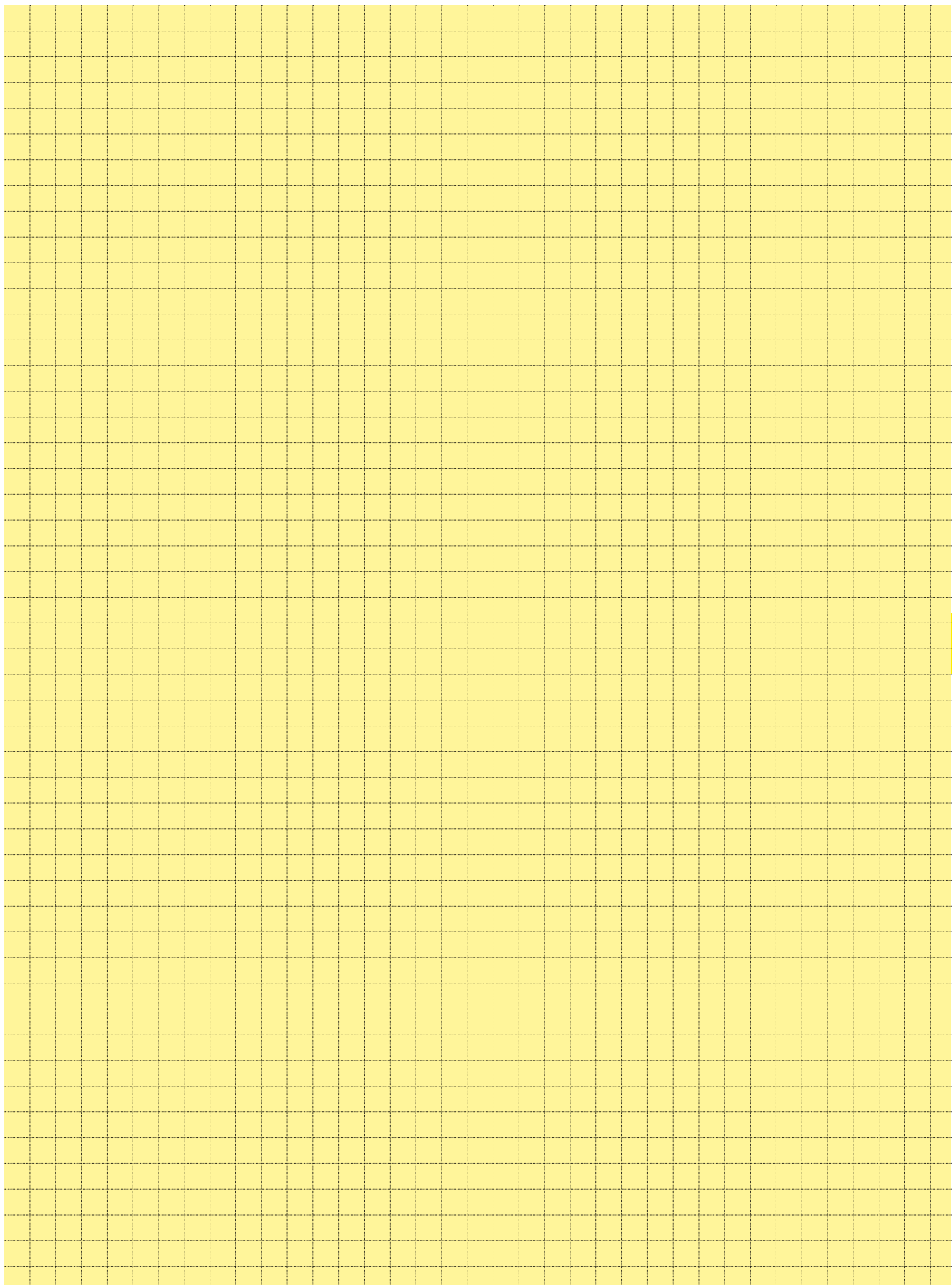

Number of contacts

6-64

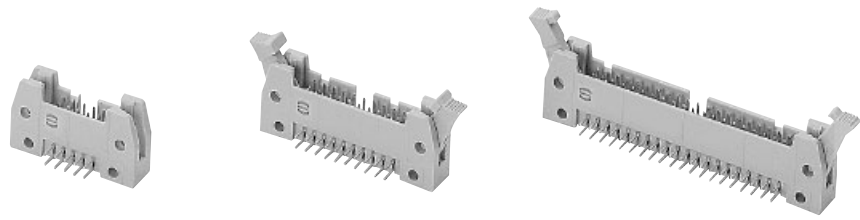

Male header with angled solder pins

Identification	No. of contacts	Part No.					
		Without levers		With short levers		With long levers	
Male header with angled solder pins Length: 2.9 mm							
	6	09 18 506	└ 923	09 18 506	└ 913	09 18 506	└ 903
	10	09 18 510	└ 923	09 18 510	└ 913	09 18 510	└ 903
	14	09 18 514	└ 923	09 18 514	└ 913	09 18 514	└ 903
	16	09 18 516	└ 923	09 18 516	└ 913	09 18 516	└ 903
	20	09 18 520	└ 923	09 18 520	└ 913	09 18 520	└ 903
	24	09 18 524	└ 923	09 18 524	└ 913	09 18 524	└ 903
	26	09 18 526	└ 923	09 18 526	└ 913	09 18 526	└ 903
	30	09 18 530	└ 923	09 18 530	└ 913	09 18 530	└ 903
	34	09 18 534	└ 923	09 18 534	└ 913	09 18 534	└ 903
	40	09 18 540	└ 923	09 18 540	└ 913	09 18 540	└ 903
	50	09 18 550	└ 923	09 18 550	└ 913	09 18 550	└ 903
	60	09 18 560	└ 923	09 18 560	└ 913	09 18 560	└ 903
	64	09 18 564	└ 923	09 18 564	└ 913	09 18 564	└ 903
Kinked version on request							
Male header with angled solder pins Length: 4.5 mm							
	6	09 18 506	└ 921*	09 18 506	└ 911*	09 18 506	└ 901*
	10	09 18 510	└ 921*	09 18 510	└ 911*	09 18 510	└ 901*
	14	09 18 514	└ 921*	09 18 514	└ 911*	09 18 514	└ 901*
	16	09 18 516	└ 921*	09 18 516	└ 911*	09 18 516	└ 901*
	20	09 18 520	└ 921*	09 18 520	└ 911*	09 18 520	└ 901*
	24	09 18 524	└ 921*	09 18 524	└ 911*	09 18 524	└ 901*
	26	09 18 526	└ 921*	09 18 526	└ 911*	09 18 526	└ 901*
	30	09 18 530	└ 921*	09 18 530	└ 911*	09 18 530	└ 901*
	34	09 18 534	└ 921*	09 18 534	└ 911*	09 18 534	└ 901*
	40	09 18 540	└ 921*	09 18 540	└ 911*	09 18 540	└ 901*
	50	09 18 550	└ 921*	09 18 550	└ 911*	09 18 550	└ 901*
	60	09 18 560	└ 921*	09 18 560	└ 911*	09 18 560	└ 901*
	64	09 18 564	└ 921*	09 18 564	└ 911*	09 18 564	└ 901*
Kinked version on request							

SEK

09-06

* Not normally kept in stock
For accessories see page 09.16
For dimensions see page 09.07

For performance level 3 please specify digit 7*
For performance level 2 please specify digit 6*
S4 = 0.76 µm (30 µinch) Au or PdNi equivalent

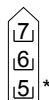

Number of contacts

6-64

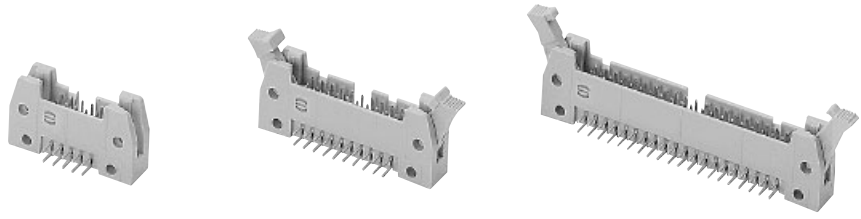

Male header with angled solder pins

Identification

Drawing

Dimensions in mm

Male header

No. of contacts	A	B	D	E	F	G
6	26.9	16.76	12.45	2.54 x 2 = 5.08	36.9	40.3
10	32.0	21.84	17.53	2.54 x 4 = 10.16	42.0	45.4
14	37.1	26.92	22.61	2.54 x 6 = 15.24	47.1	50.4
16	39.6	29.46	25.15	2.54 x 7 = 17.78	49.6	53.0
20	44.7	34.54	30.23	2.54 x 9 = 22.86	54.7	58.1
24	49.8	39.62	35.91	2.54 x 11 = 27.94	59.8	63.2
26	52.3	42.16	37.85	2.54 x 12 = 30.48	62.3	65.7
30	57.7	47.24	43.83	2.54 x 14 = 35.56	68.2	68.6
34	62.5	52.32	48.01	2.54 x 16 = 40.64	72.5	75.8
40	70.1	59.94	55.63	2.54 x 19 = 48.26	80.1	83.5
50	82.8	72.64	68.33	2.54 x 24 = 60.96	92.8	96.2
60	95.5	85.34	81.03	2.54 x 29 = 73.66	105.5	108.9
64	100.6	90.42	86.11	2.54 x 31 = 78.74	110.6	113.9

Short levers

for use with female connector without strain relief clamp

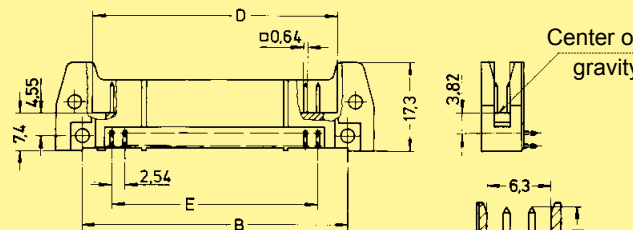

Long levers

for use with female connector with strain relief clamp

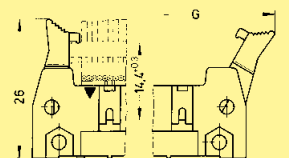
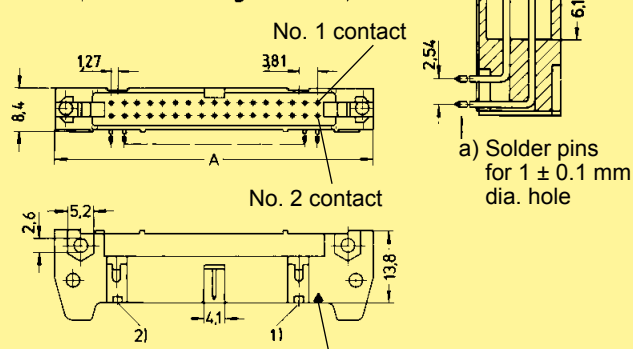

Board drillings

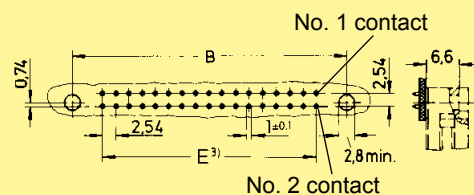

For accessories see page 09.16

¹⁾ No polarization slot for 6, 10 or 14 way male header

²⁾ No polarization slot for 6 way male header

³⁾ Pitch tolerance: ± 0.1

Number of contacts

6-64

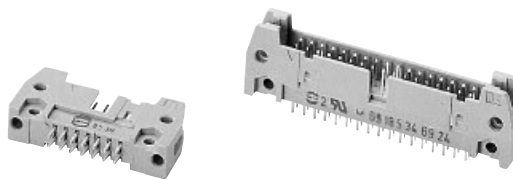

Male header with straight solder pins

Identification	No. of contacts	Part No.					
		Without levers		With short levers		With long levers	
Male header with straight solder pins Length: 2.9 mm	6	09 18 506	└ 924	09 18 506	└ 914	09 18 506	└ 904
	10	09 18 510	└ 924	09 18 510	└ 914	09 18 510	└ 904
	14	09 18 514	└ 924	09 18 514	└ 914	09 18 514	└ 904
	16	09 18 516	└ 924	09 18 516	└ 914	09 18 516	└ 904
	20	09 18 520	└ 924	09 18 520	└ 914	09 18 520	└ 904
	24	09 18 524	└ 924	09 18 524	└ 914	09 18 524	└ 904
	26	09 18 526	└ 924	09 18 526	└ 914	09 18 526	└ 904
	30	09 18 530	└ 924	09 18 530	└ 914	09 18 530	└ 904
	34	09 18 534	└ 924	09 18 534	└ 914	09 18 534	└ 904
	40	09 18 540	└ 924	09 18 540	└ 914	09 18 540	└ 904
	50	09 18 550	└ 924	09 18 550	└ 914	09 18 550	└ 904
	60	09 18 560	└ 924	09 18 560	└ 914	09 18 560	└ 904
	64	09 18 564	└ 924	09 18 564	└ 914	09 18 564	└ 904
	Male header with straight solder pins Length: 4.5 mm	6	09 18 506	└ 922*	09 18 506	└ 912*	09 18 506
10		09 18 510	└ 922*	09 18 510	└ 912*	09 18 510	└ 902*
14		09 18 514	└ 922*	09 18 514	└ 912*	09 18 514	└ 902*
16		09 18 516	└ 922*	09 18 516	└ 912*	09 18 516	└ 902*
20		09 18 520	└ 922*	09 18 520	└ 912*	09 18 520	└ 902*
24		09 18 524	└ 922*	09 18 524	└ 912*	09 18 524	└ 902*
26		09 18 526	└ 922*	09 18 526	└ 912*	09 18 526	└ 902*
30		09 18 530	└ 922*	09 18 530	└ 912*	09 18 530	└ 902*
34		09 18 534	└ 922*	09 18 534	└ 912*	09 18 534	└ 902*
40		09 18 540	└ 922*	09 18 540	└ 912*	09 18 540	└ 902*
50		09 18 550	└ 922*	09 18 550	└ 912*	09 18 550	└ 902*
60		09 18 560	└ 922*	09 18 560	└ 912*	09 18 560	└ 902*
64		09 18 564	└ 922*	09 18 564	└ 912*	09 18 564	└ 902*

Kinked version on request

* Not normally kept in stock
For accessories see page 09.16
For dimensions see page 09.09

For performance level 3 please specify digit $\begin{matrix} \boxed{7} \\ \boxed{6} \\ \boxed{5} \end{matrix}^*$
For performance level 2 please specify digit $\begin{matrix} \boxed{7} \\ \boxed{6} \\ \boxed{5} \end{matrix}^*$
S4 = 0.76 µm (30 µinch) Au or PdNi equivalent

Number of contacts

6-64

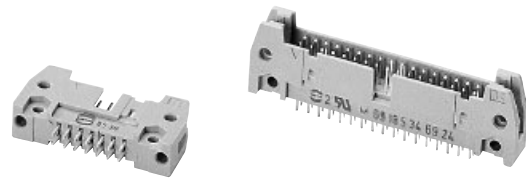

Male header with straight solder pins

Identification

Drawing

Dimensions in mm

Male header

No. of contacts	A	C	D	E	F	G
6	26.9	22.86	12.45	2.54 x 2 = 5.08	36.9	40.3
10	32.0	27.94	17.53	2.54 x 4 = 10.16	42.0	45.4
14	37.1	33.02	22.61	2.54 x 6 = 15.24	47.1	50.4
16	39.6	35.56	25.15	2.54 x 7 = 17.78	49.6	53.0
20	44.7	40.64	30.23	2.54 x 9 = 22.86	54.7	58.1
24	49.8	45.72	35.91	2.54 x 11 = 27.94	59.8	63.2
26	52.3	48.26	37.85	2.54 x 12 = 30.48	62.3	65.7
30	57.7	53.34	43.83	2.54 x 14 = 35.56	68.2	68.6
34	62.5	58.42	48.01	2.54 x 16 = 40.64	72.5	75.8
40	70.1	66.04	55.63	2.54 x 19 = 48.26	80.1	83.5
50	82.8	78.74	68.33	2.54 x 24 = 60.96	92.8	96.2
60	95.5	91.44	81.03	2.54 x 29 = 73.66	105.5	108.9
64	100.6	96.52	86.11	2.54 x 31 = 78.74	110.6	113.9

Short levers

for use with female connector without strain relief clamp

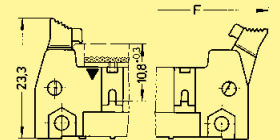
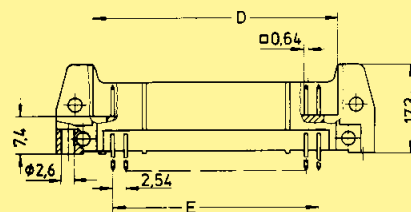

Long levers

for use with female connector with strain relief clamp

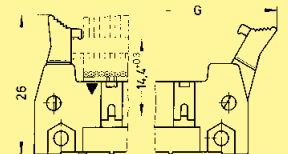
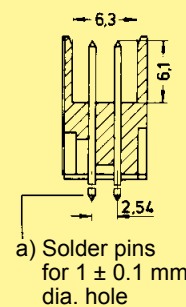
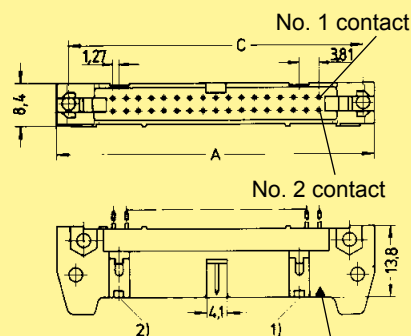

Marking No. 1 contact

Board drillings

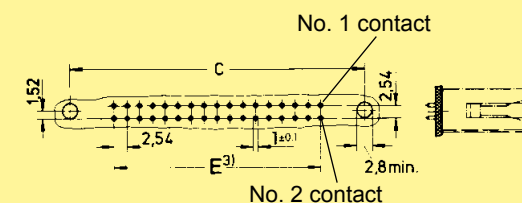

Number of contacts

6-64

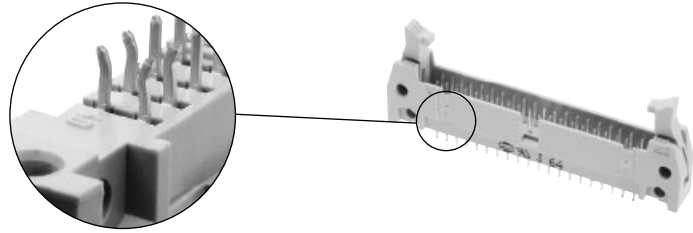

Male header with straight solder pins, kinked

Identification	No. of contacts	Part No.					
		Without levers		With short levers		With long levers	
Male header with straight solder pins, kinked Length: 2.9 mm	6	09 18 506	└ 024	09 18 506	└ 014	09 18 506	└ 004
	10	09 18 510	└ 024	09 18 510	└ 014	09 18 510	└ 004
	14	09 18 514	└ 024	09 18 514	└ 014	09 18 514	└ 004
	16	09 18 516	└ 024	09 18 516	└ 014	09 18 516	└ 004
	20	09 18 520	└ 024	09 18 520	└ 014	09 18 520	└ 004
	24	09 18 524	└ 024	09 18 524	└ 014	09 18 524	└ 004
	26	09 18 526	└ 024	09 18 526	└ 014	09 18 526	└ 004
	30	09 18 530	└ 024	09 18 530	└ 014	09 18 530	└ 004
	34	09 18 534	└ 024	09 18 534	└ 014	09 18 534	└ 004
	40	09 18 540	└ 024	09 18 540	└ 014	09 18 540	└ 004
	50	09 18 550	└ 024	09 18 550	└ 014	09 18 550	└ 004
	60	09 18 560	└ 024	09 18 560	└ 014	09 18 560	└ 004
	64	09 18 564	└ 024	09 18 564	└ 014	09 18 564	└ 004

SEK

09
10

* Not normally kept in stock
 For accessories see page 09.16
 For dimensions see page 09.11

For performance level 3 please specify digit
 For performance level 2 please specify digit
 S4 = 0.76 µm (30 µinch) Au or PdNi equivalent

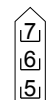

Number of contacts

6-64

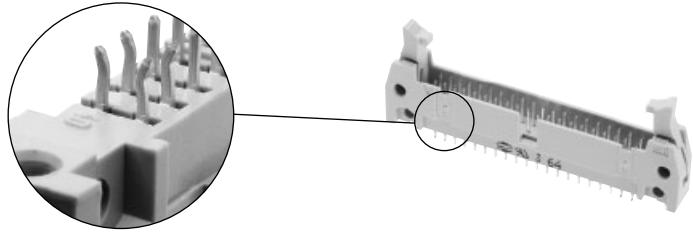

Male header with straight solder pins, kinked

Identification

Drawing

Dimensions in mm

Male header

No. of contacts	A	C	D	E	F	G
6	26.9	22.86	12.45	2.54 x 2 = 5.08	36.9	40.3
10	32.0	27.94	17.53	2.54 x 4 = 10.16	42.0	45.4
14	37.1	33.02	22.61	2.54 x 6 = 15.24	47.1	50.4
16	39.6	35.56	25.15	2.54 x 7 = 17.78	49.6	53.0
20	44.7	40.64	30.23	2.54 x 9 = 22.86	54.7	58.1
24	49.8	45.72	35.91	2.54 x 11 = 27.94	59.8	63.2
26	52.3	48.26	37.85	2.54 x 12 = 30.48	62.3	65.7
30	57.7	53.34	43.83	2.54 x 14 = 35.56	68.2	68.6
34	62.5	58.42	48.01	2.54 x 16 = 40.64	72.5	75.8
40	70.1	66.04	55.63	2.54 x 19 = 48.26	80.1	83.5
50	82.8	78.74	68.33	2.54 x 24 = 60.96	92.8	96.2
60	95.5	91.44	81.03	2.54 x 29 = 73.66	105.5	108.9
64	100.6	96.52	86.11	2.54 x 31 = 78.74	110.6	113.9

Short levers

for use with female connector without strain relief clamp

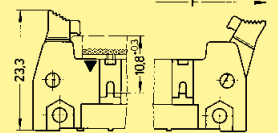
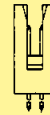
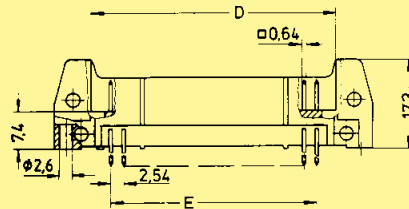

Long levers

for use with female connector with strain relief clamp

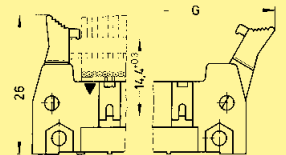
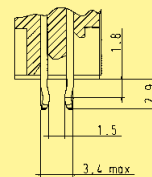
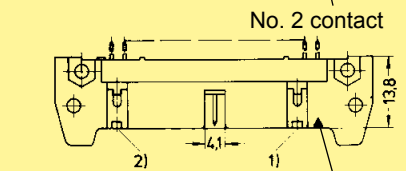
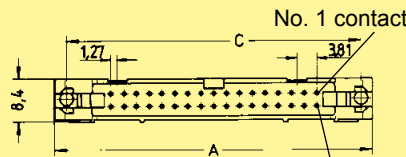

Marking No. 1 contact

No. 1 contact

Board drillings

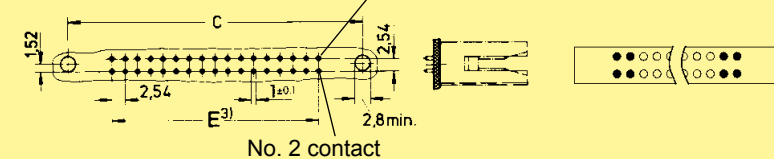

● Kinked contact: pcb thickness from 1.50 to 1.94 mm after Cu + Sn plating with non-remelted through holes \varnothing 0.80 to \varnothing 0.95 mm. Max. insertion force = 125 N. Min. retention force = 3 N.

○ Non-kinked contact: Solder pins for pcb connections \varnothing 1 ± 0.1 mm as per IEC 60603-13.

For accessories see page 09.16

1) No polarization slot for 6, 10 or 14 way male header

2) No polarization slot for 6 way male header

3) Pitch tolerance: ± 0.1

Number of contacts

6-64



Male header with angled solder pins and board lock

Identification	No. of contacts	Part No.					
		Without levers		With short levers		With long levers	
<p>Male header with angled solder pins and pcb board lock</p> <p>Length: 2.9 mm for 1.6 mm pcb thickness</p> <p>To hold the connector on the pcb before the soldering process, two board locks have been added on the male header with angled solder pins.</p>	6	09 18 506	└ 973*	09 18 506	└ 963*	09 18 506	└ 953*
	10	09 18 510	└ 973*	09 18 510	└ 963*	09 18 510	└ 953*
	14	09 18 514	└ 973*	09 18 514	└ 963*	09 18 514	└ 953*
	16	09 18 516	└ 973*	09 18 516	└ 963*	09 18 516	└ 953*
	20	09 18 520	└ 973*	09 18 520	└ 963*	09 18 520	└ 953*
	24	09 18 524	└ 973*	09 18 524	└ 963*	09 18 524	└ 953*
	26	09 18 526	└ 973*	09 18 526	└ 963*	09 18 526	└ 953*
	30	09 18 530	└ 973*	09 18 530	└ 963*	09 18 530	└ 953*
	34	09 18 534	└ 973*	09 18 534	└ 963*	09 18 534	└ 953*
	40	09 18 540	└ 973*	09 18 540	└ 963*	09 18 540	└ 953*
	50	09 18 550	└ 973*	09 18 550	└ 963*	09 18 550	└ 953*
	60	09 18 560	└ 973*	09 18 560	└ 963*	09 18 560	└ 953*
	64	09 18 564	└ 973*	09 18 564	└ 963*	09 18 564	└ 953*

SEK

09-12

* Not normally kept in stock

For performance level 3 please specify digit
 For performance level 2 please specify digit
 S4 = 0.76 µm (30 µinch) Au or PdNi equivalent

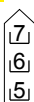
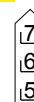
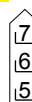

Number of contacts

6-64

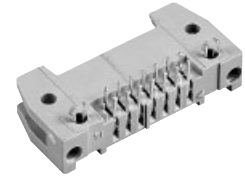

Male header with angled solder pins and board lock

Identification

Drawing

Dimensions in mm

Male header

No. of contacts	A	B	D	E	F	G
6	26.9	16.76	12.45	2.54 x 2 = 5.08	36.9	40.3
10	32.0	21.84	17.53	2.54 x 4 = 10.16	42.0	45.4
14	37.1	26.92	22.61	2.54 x 6 = 15.24	47.1	50.4
16	39.6	29.46	25.15	2.54 x 7 = 17.78	49.6	53.0
20	44.7	34.54	30.23	2.54 x 9 = 22.86	54.7	58.1
24	49.8	39.62	35.91	2.54 x 11 = 27.94	59.8	63.2
26	52.3	42.16	37.85	2.54 x 12 = 30.48	62.3	65.7
30	57.7	47.24	43.83	2.54 x 14 = 35.56	68.2	68.6
34	62.5	52.32	48.01	2.54 x 16 = 40.64	72.5	75.8
40	70.1	59.94	55.63	2.54 x 19 = 48.26	80.1	83.5
50	82.8	72.64	68.33	2.54 x 24 = 60.96	92.8	96.2
60	95.5	85.34	81.03	2.54 x 29 = 73.66	105.5	108.9
64	100.6	90.42	86.11	2.54 x 31 = 78.74	110.6	113.9

Short levers

for use with female connector without strain relief clamp

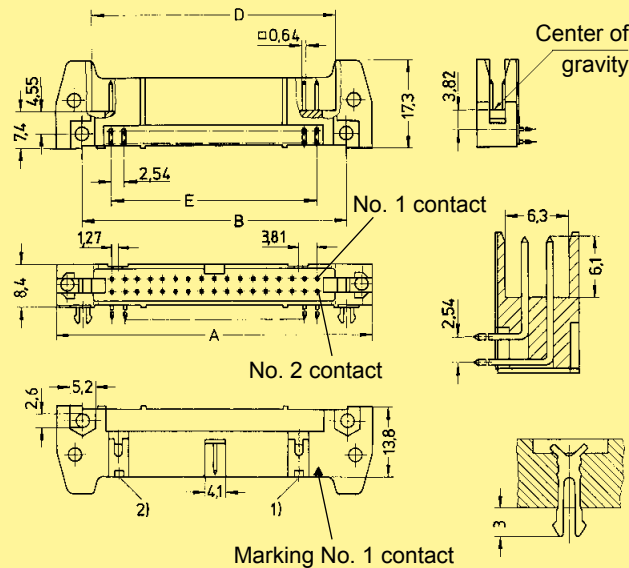

Long levers

for use with female connector with strain relief clamp

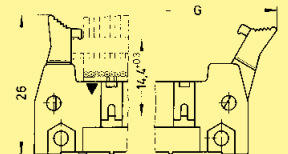

Board drillings

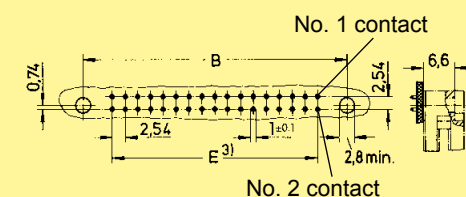

1) No polarization slot for 6, 10 or 14 way male header

2) No polarization slot for 6 way male header

3) Pitch tolerance: ± 0.1

Number of contacts

6-64

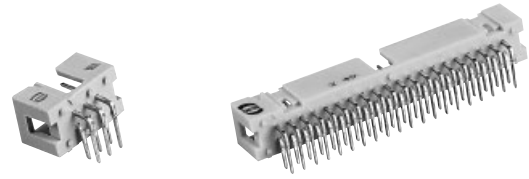

Low-profile male header, angled solder pins

Identification No. of contacts Part No. Drawing Dimensions in mm

Male header with angled solder pins

Length: 2.9 mm

6	09 18 506	□ 323
10	09 18 510	□ 323
14	09 18 514	□ 323
16	09 18 516	□ 323
20	09 18 520	□ 323
26	09 18 526	□ 323
30	09 18 530	□ 323
34	09 18 534	□ 323
40	09 18 540	□ 323
50	09 18 550	□ 323
60	09 18 560	□ 323
64	09 18 564	□ 323

No. of contacts	A	B	E
6	15.2	12.78	2.54 x 2 = 5.08
10	20.3	17.86	2.54 x 4 = 10.16
14	25.4	22.94	2.54 x 6 = 15.24
16	27.9	25.48	2.54 x 7 = 17.78
20	33.0	30.56	2.54 x 9 = 22.86
26	40.6	38.18	2.54 x 12 = 30.48
30	45.72	43.26	2.54 x 14 = 35.56
34	50.8	48.34	2.54 x 16 = 40.64
40	58.4	55.96	2.54 x 19 = 48.26
50	71.3	68.66	2.54 x 24 = 60.96
60	84.0	81.36	2.54 x 29 = 73.66
64	89.1	86.44	2.54 x 31 = 78.74

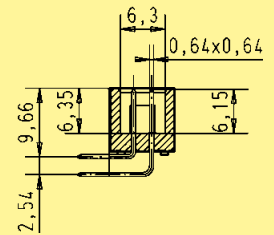

Solder pins for 1 ± 0.1 mm dia. hole

Marking No. 1 contact

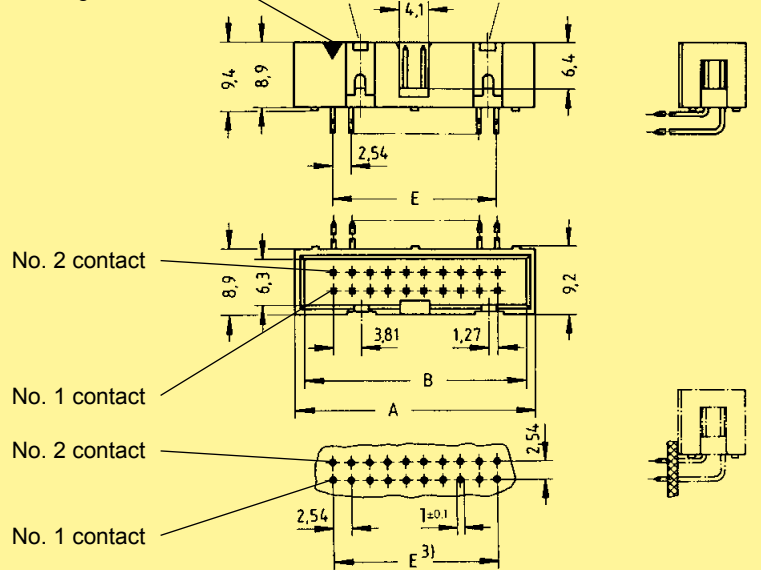

For performance level 3 please specify digit 7
 For performance level 2 please specify digit 6
 S4 = 0.76 µm (30 µinch) Au or PdNi equivalent

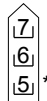

Identification Part No. Drawing Dimensions in mm

Locking lever for female connector with strain relief

in conjunction with low-profile male header

When the security of latching is required and space is a premium, these locking levers can be fitted onto the strain relief of the HARTING female connector.

09 18 000 9905⁴⁾

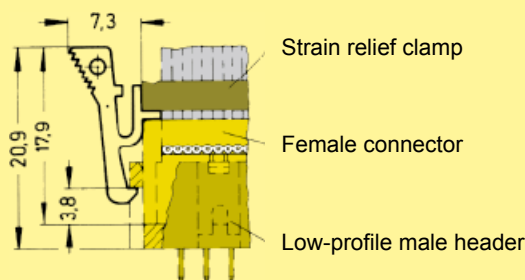

* Not normally kept in stock

¹⁾ No polarization slot for 6, 10 or 14 way male header
²⁾ No polarization slot for 6 way male header

³⁾ Pitch tolerance: ± 0.1
⁴⁾ Order 2 per female connector

Number of contacts

6-64



Low-profile male header, straight solder pins

Identification No. of contacts Part No. Drawing Dimensions in mm

Male header with straight solder pins

Length: 2.9 mm

6	09 18 506	└ 324
10	09 18 510	└ 324
14	09 18 514	└ 324
16	09 18 516	└ 324
20	09 18 520	└ 324
26	09 18 526	└ 324
30	09 18 530	└ 324
34	09 18 534	└ 324
40	09 18 540	└ 324
50	09 18 550	└ 324
60	09 18 560	└ 324
64	09 18 564	└ 324

No. of contacts	A	B	E
6	15.2	12.78	2.54 x 2 = 5.08
10	20.3	17.86	2.54 x 4 = 10.16
14	25.4	22.94	2.54 x 6 = 15.24
16	27.9	25.48	2.54 x 7 = 17.78
20	33.0	30.56	2.54 x 9 = 22.86
26	40.6	38.18	2.54 x 12 = 30.48
30	45.72	43.26	2.54 x 14 = 35.56
34	50.8	48.34	2.54 x 16 = 40.64
40	58.4	55.96	2.54 x 19 = 48.26
50	71.3	68.66	2.54 x 24 = 60.96
60	84.0	81.36	2.54 x 29 = 73.66
64	89.1	86.44	2.54 x 31 = 78.74

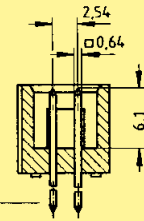

Solder pins for 1 ± 0.1 mm dia. hole

Male header with straight solder pins

Length: 4.5 mm

6	09 18 506	└ 322*
10	09 18 510	└ 322*
14	09 18 514	└ 322*
16	09 18 516	└ 322*
20	09 18 520	└ 322*
26	09 18 526	└ 322*
30	09 18 530	└ 322*
34	09 18 534	└ 322*
40	09 18 540	└ 322*
50	09 18 550	└ 322*
60	09 18 560	└ 322*
64	09 18 564	└ 322*

Marking No. 1 contact

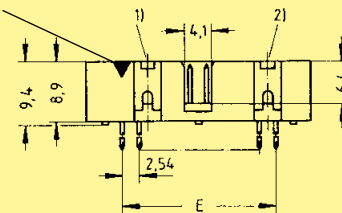

No. 2 contact

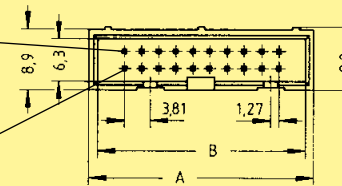

No. 1 contact

No. 2 contact

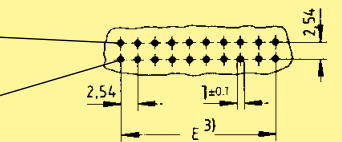

No. 1 contact

For performance level 3 please specify digit 7
 For performance level 2 please specify digit 6
 S4 = 0.76 µm (30 pinch) Au or PdNi equivalent



Identification

Part No.

Drawing

Dimensions in mm

Locking lever for female connector with strain relief

in conjunction with low-profile male header

When the security of latching is required and space is a premium, these locking levers can be fitted onto the strain relief of the HARTING female connector.

09 18 000 9905⁴⁾

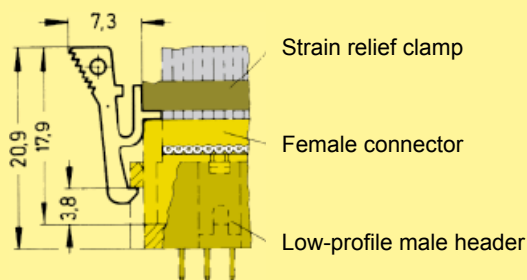

* Not normally kept in stock

¹⁾ No polarization slot for 6, 10 or 14 way male header
²⁾ No polarization slot for 6 way male header

³⁾ Pitch tolerance: ± 0.1
⁴⁾ Order 2 per female connector

Accessories

Identification	Part No.	Drawing	Dimensions in mm
<p>Polarization key</p> <p>1) Part No. comprises 2 keys</p>	<p>09 18 500 9902¹⁾</p>		
<p>Locking lever (snaps into place, can be fitted whenever required)</p> <p>2) Order 2 per male header</p>	<p>Long: 09 18 000 9903²⁾</p> <p>Short: 09 18 000 9904²⁾</p>	<p>Long</p> <p>Short</p> <p>For use with female connector <u>with</u> strain relief clamp</p> <p>For use with female connector <u>without</u> strain relief clamp</p>	
<p>Fixing screws for 1.6 mm P.C. board</p> <p>3) Part No. comprises 50 pieces</p>	<p>09 18 000 9906³⁾</p>		
<p>Coding system with loss of contact</p> <p>4) Part No. comprises 6 code pins</p>	<p>Code pin 09 18 000 9901⁴⁾</p> <p>Removal tool for male contacts 09 99 000 0133</p>	<p>To avoid cross-plugging adjacent connectors a coding system is required. A code pin is inserted into the appropriate cavity in the female connector. The corresponding male contact is removed by a special removal tool.</p>	

SEK

Number of contacts	6, 10, 14, 16, 20, 24, 26, 30, 34, 40, 50, 60, 64
Contact arrangement	straight, angled
Contact length	15 mm
Approvals	IEC 60 603-13 DIN EN 60 603-13 D 2632 BT 224 NFC 93-428 (HE 10)
Pitch	2.54 mm [0.100"]
Working current	1 A
Working voltage	500 V for pollution degree 1
Test voltage $U_{r.m.s.}$	1 kV
Contact resistance	$\leq 20 \text{ m}\Omega$
Insulation resistance	$\geq 10^9 \Omega$
Temperature range	-55 °C ... + 125 °C The maximum temperature includes heating of contacts and ambient temperature
Terminations	0.6 mm x 0.6 mm Diagonal: 0.86 mm
Materials	
Moulding	Thermoplastic resin (PBT) UL 94-V0
Contact surface	
Contact zone	plated according to performance level ¹⁾

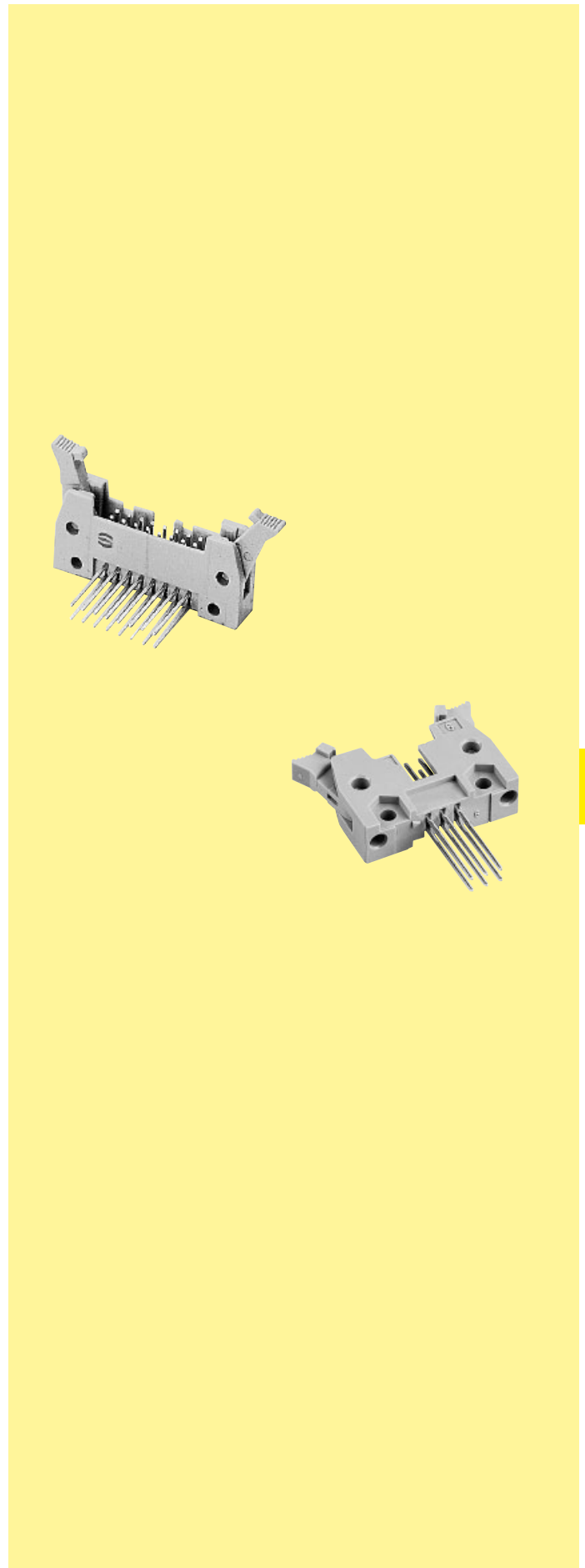

¹⁾ Performance level 3 as per IEC 60 603-13, ≥ 50 mating cycles, no gas test
Performance level 2 as per IEC 60 603-13, ≥ 250 mating cycles, 4 days gas test
S4, plating = 0.76 μm (30 μinch) Au or PdNi equivalent

Number of contacts

6-64

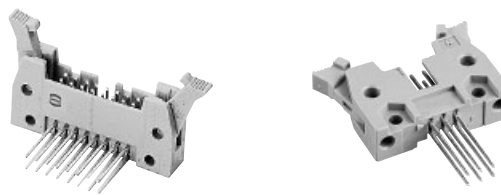

Male header with wrap posts

Identification	No. of contacts	Part No.					
		Without levers		With short levers		With long levers	
Male header with angled wrap posts Length: 15 mm □ 0.6 mm	6	09 18 506	└ 926*	09 18 506	└ 916*	09 18 506	└ 906*
	10	09 18 510	└ 926*	09 18 510	└ 916*	09 18 510	└ 906*
	14	09 18 514	└ 926*	09 18 514	└ 916*	09 18 514	└ 906*
	16	09 18 516	└ 926*	09 18 516	└ 916*	09 18 516	└ 906*
	20	09 18 520	└ 926*	09 18 520	└ 916*	09 18 520	└ 906*
	24	09 18 524	└ 926*	09 18 524	└ 916*	09 18 524	└ 906*
	26	09 18 526	└ 926*	09 18 526	└ 916*	09 18 526	└ 906*
	30	09 18 530	└ 926*	09 18 530	└ 916*	09 18 530	└ 906*
	34	09 18 534	└ 926*	09 18 534	└ 916*	09 18 534	└ 906*
	40	09 18 540	└ 926*	09 18 540	└ 916*	09 18 540	└ 906*
	50	09 18 550	└ 926*	09 18 550	└ 916*	09 18 550	└ 906*
	60	09 18 560	└ 926*	09 18 560	└ 916*	09 18 560	└ 906*
	64	09 18 564	└ 926*	09 18 564	└ 916*	09 18 564	└ 906*
	Male header with straight wrap posts Length: 15 mm □ 0.6 mm	6	09 18 506	└ 927*	09 18 506	└ 917*	09 18 506
10		09 18 510	└ 927*	09 18 510	└ 917*	09 18 510	└ 907*
14		09 18 514	└ 927*	09 18 514	└ 917*	09 18 514	└ 907*
16		09 18 516	└ 927*	09 18 516	└ 917*	09 18 516	└ 907*
20		09 18 520	└ 927*	09 18 520	└ 917*	09 18 520	└ 907*
24		09 18 524	└ 927*	09 18 524	└ 917*	09 18 524	└ 907*
26		09 18 526	└ 927*	09 18 526	└ 917*	09 18 526	└ 907*
30		09 18 530	└ 927*	09 18 530	└ 917*	09 18 530	└ 907*
34		09 18 534	└ 927*	09 18 534	└ 917*	09 18 534	└ 907*
40		09 18 540	└ 927*	09 18 540	└ 917*	09 18 540	└ 907*
50		09 18 550	└ 927*	09 18 550	└ 917*	09 18 550	└ 907*
60		09 18 560	└ 927*	09 18 560	└ 917*	09 18 560	└ 907*
64		09 18 564	└ 927*	09 18 564	└ 917*	09 18 564	└ 907*

SEK

* Not normally kept in stock
 For accessories see page 09.20
 For dimensions see page 09.19

For performance level 3 please specify digit
 For performance level 2 please specify digit
 S4 = 0.76 µm (30 µinch) Au or PdNi equivalent

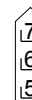
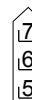
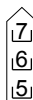

Number of contacts

6-64

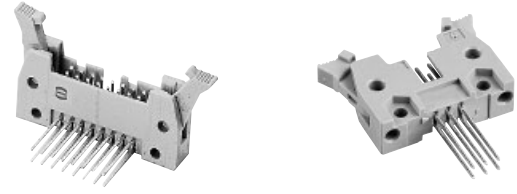

Male header with wrap posts

Identification

Drawing

Dimensions in mm

Male header

No. of contacts	A	B	C	D	E	F	G
6	26.9	16.76	22.86	12.45	2.54 x 2 = 5.08	36.9	40.3
10	32.0	21.84	27.94	17.53	2.54 x 4 = 10.16	42.0	45.4
14	37.1	26.92	33.02	22.61	2.54 x 6 = 15.24	47.1	50.4
16	39.6	29.46	35.56	25.15	2.54 x 7 = 17.78	49.6	53.0
20	44.7	34.54	40.64	30.23	2.54 x 9 = 22.86	54.7	58.1
24	49.8	39.62	45.72	35.91	2.54 x 11 = 27.94	59.8	63.2
26	52.3	42.16	48.26	37.85	2.54 x 12 = 30.48	62.3	65.7
30	57.7	47.24	53.43	43.83	2.54 x 14 = 35.56	68.2	68.6
34	62.5	52.32	58.42	48.01	2.54 x 16 = 40.64	72.5	75.8
40	70.1	59.94	66.04	55.63	2.54 x 19 = 48.26	80.1	83.5
50	82.8	72.64	78.74	68.33	2.54 x 24 = 60.96	92.8	96.2
60	95.5	85.34	91.44	81.03	2.54 x 29 = 73.66	105.5	108.9
64	100.6	90.42	96.52	86.11	2.54 x 31 = 78.74	110.6	113.9

Long levers

for use with female connector with strain relief clamp

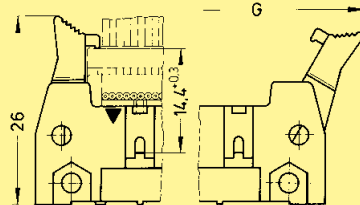

Short levers

for use with female connector without strain relief clamp

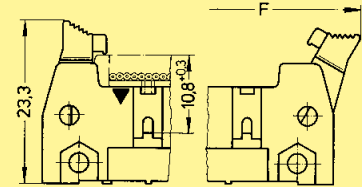

Angled versions

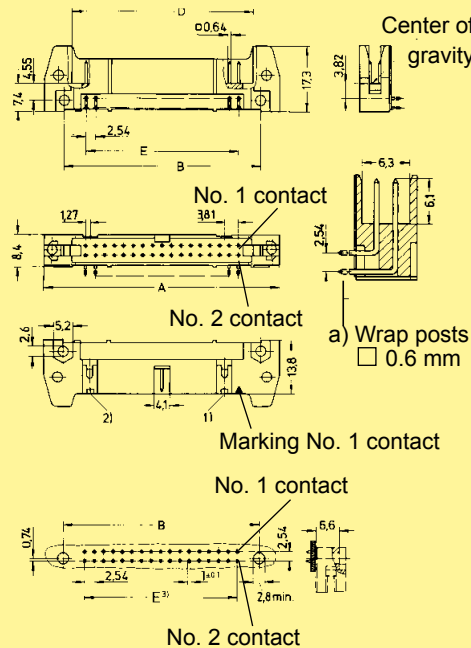

Straight versions

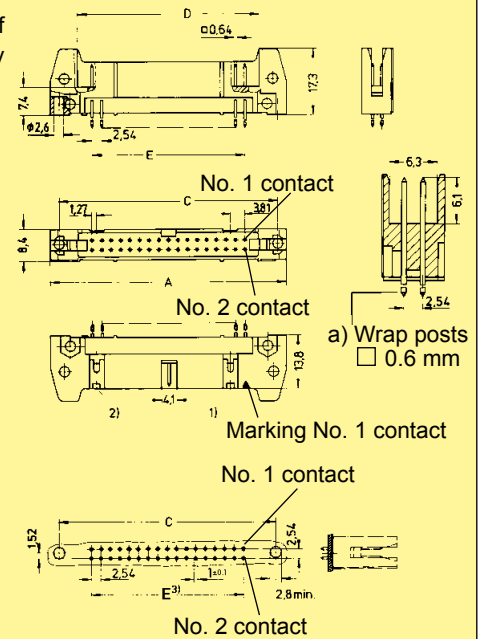

Board drillings

For accessories see page 09.20

¹⁾ No polarization slot for 6, 10 or 14 way male header

²⁾ No polarization slot for 6 way male header
³⁾ Pitch tolerance: ± 0.1

Accessories

Identification	Part No.	Drawing	Dimensions in mm
<p>Polarization key</p> <p>1) Part No. comprises 2 keys</p>	<p>09 18 500 9902¹⁾</p>		
<p>Locking lever (snaps into place, can be fitted whenever required)</p> <p>2) Order 2 per male header</p>	<p>Long: 09 18 000 9903²⁾</p> <p>Short: 09 18 000 9904²⁾</p>	<p>Long</p> <p>Short</p> <p>For use with female connector <u>with</u> strain relief clamp</p> <p>For use with female connector <u>without</u> strain relief clamp</p>	
<p>Fixing screws for 1.6 mm P.C. board</p> <p>3) Part No. comprises 50 pieces</p>	<p>09 18 000 9906³⁾</p>		
<p>Coding system with loss of contact</p> <p>4) Part No. comprises 6 code pins</p>	<p>Code pin 09 18 000 9901⁴⁾</p> <p>Removal tool for male contacts 09 99 000 0133</p>	<p>To avoid cross-plugging adjacent connectors a coding system is required. A code pin is inserted into the appropriate cavity in the female connector. The corresponding male contact is removed by a special removal tool.</p>	

SEK

Number of contacts 6, 10, 14, 16, 20, 24, 26, 30, 34, 40, 50, 60, 64

Approvals IEC 60 603-13
DIN EN 60 603-13
D 2632
BT 224
NFC 93-428 (HE 10)
UL recognized: E102079



Pitch 2.54 mm [0.100"]

Working current 1 A

Working voltage 320 V
for pollution degree 1

Test voltage $U_{r.m.s.}$ 1 kV

Contact resistance $\leq 20 \text{ m}\Omega$
Insulation resistance $\geq 10^9 \Omega$

Temperature range -55 °C ... + 125 °C
The maximum temperature includes heating of contacts and ambient temperature

Terminations IDC flat cable
1.27 mm [0.050"] pitch:
AWG 26/7 – AWG 28/7

Materials Moulding Thermoplastic resin (PBT)
UL 94-V0

Contact surface Contact zone gold-plated according to performance level¹⁾

Current carrying capacity

The current carrying capacity is limited by maximum temperature of materials for inserts and contacts including terminals. The current capacity-curve is valid for continuous, not interrupted current-loaded contacts of connectors when simultaneous power on all contacts is given, without exceeding the maximum temperature.

Control and test procedures according to DIN IEC 60 512.

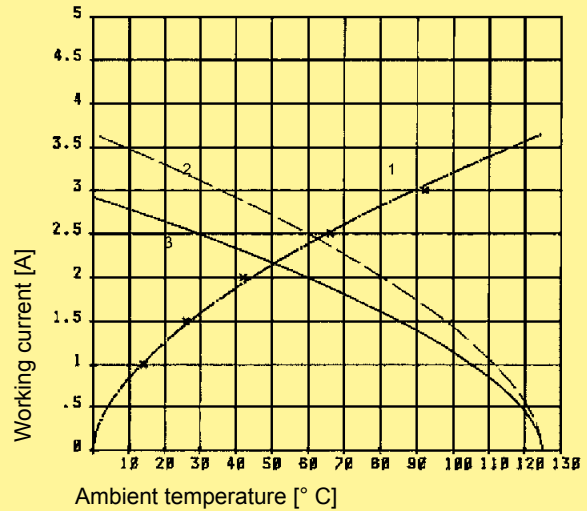

Example: 50 way connector

- ① Temperature rise
- ② Derating
- ③ Derating curve at $I_{max} \times 0.8$ (IEC 60 512-2)

Insertion and withdrawal forces

Number of contacts	Maximum force [N]	
	Performance level 1 and 2	Performance level 3
6	12	18
10	20	30
14	28	42
16	32	48
20	40	60
24	48	72
26	52	78
30	60	90
34	68	102
40	80	120
50	100	150
60	120	180
64	128	192



¹⁾ Performance level 3 as per IEC 60 603-13, ≥ 50 mating cycles, no gas test
Performance level 2 as per IEC 60 603-13, ≥ 250 mating cycles, 4 days gas test
S4, plating = 0.76 μm (30 μinch) Au or PdNi equivalent



Number of contacts

6-64

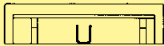
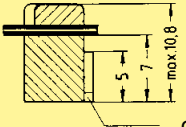
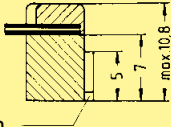
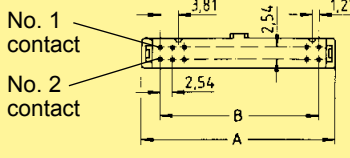
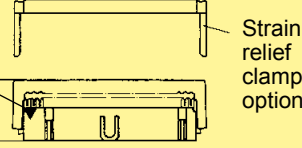

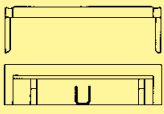
Female connector

Identification	No. of contacts	Part No.		Drawing	Dimensions in mm																																																																		
Female connector with central polarization without strain relief clamp 		open end cover	closed end cover	open end cover	closed end cover																																																																		
	6	09 18 506 □ 803	09 18 506 □ 804																																																																				
	10	09 18 510 □ 803	09 18 510 □ 804	option																																																																			
	14	09 18 514 □ 803	09 18 514 □ 804																																																																				
	16	09 18 516 □ 803	09 18 516 □ 804																																																																				
	20	09 18 520 □ 803	09 18 520 □ 804																																																																				
	24	09 18 524 □ 803	09 18 524 □ 804																																																																				
	26	09 18 526 □ 803	09 18 526 □ 804																																																																				
	30	09 18 530 □ 803	09 18 530 □ 804																																																																				
	34	09 18 534 □ 803	09 18 534 □ 804																																																																				
	40	09 18 540 □ 803	09 18 540 □ 804																																																																				
	50	09 18 550 □ 803	09 18 550 □ 804																																																																				
	60	09 18 560 □ 803	09 18 560 □ 804																																																																				
	64	09 18 564 □ 803	09 18 564 □ 804																																																																				
	without strain relief clamp with bulk packaging 2) Packaging unit (PU) 5,000 pieces 3) PU 3,000 pieces	6	09 18 506 □ 803 58U ²⁾		 No. 1 contact No. 2 contact Marking No. 1 contact  Strain relief clamp option 																																																																		
		10	09 18 510 □ 803 58U ²⁾																																																																				
		14	09 18 514 □ 803 58U ²⁾																																																																				
		16	09 18 516 □ 803 58U ²⁾																																																																				
		20	09 18 520 □ 803 58U ²⁾																																																																				
		26	09 18 526 □ 803 58U ²⁾																																																																				
30		09 18 530 □ 803 58U ²⁾																																																																					
40		09 18 540 □ 803 58U ³⁾																																																																					
with strain relief clamp 	6	09 18 506 □ 813	09 18 506 □ 814*	<table border="1" style="width: 100%; border-collapse: collapse;"> <thead> <tr> <th>No. of contacts</th> <th>6</th> <th>10</th> <th>14</th> <th>16</th> <th>20</th> </tr> </thead> <tbody> <tr> <td>A</td> <td>12.20</td> <td>17.30</td> <td>22.40</td> <td>24.90</td> <td>30.00</td> </tr> <tr> <td>B</td> <td>5.08</td> <td>10.16</td> <td>15.24</td> <td>17.78</td> <td>22.86</td> </tr> <tr> <td colspan="6"> </td> </tr> <tr> <th>No. of contacts</th> <th>24</th> <th>26</th> <th>30</th> <th>34</th> <th>40</th> </tr> <tr> <td>A</td> <td>35.18</td> <td>37.60</td> <td>42.70</td> <td>47.80</td> <td>55.40</td> </tr> <tr> <td>B</td> <td>27.94</td> <td>30.48</td> <td>35.56</td> <td>40.64</td> <td>48.26</td> </tr> <tr> <td colspan="6"> </td> </tr> <tr> <th>No. of contacts</th> <th>50</th> <th>60</th> <th>64</th> <th></th> <th></th> </tr> <tr> <td>A</td> <td>68.10</td> <td>80.80</td> <td>85.90</td> <td></td> <td></td> </tr> <tr> <td>B</td> <td>60.96</td> <td>73.66</td> <td>78.74</td> <td></td> <td></td> </tr> </tbody> </table>		No. of contacts	6	10	14	16	20	A	12.20	17.30	22.40	24.90	30.00	B	5.08	10.16	15.24	17.78	22.86							No. of contacts	24	26	30	34	40	A	35.18	37.60	42.70	47.80	55.40	B	27.94	30.48	35.56	40.64	48.26							No. of contacts	50	60	64			A	68.10	80.80	85.90			B	60.96	73.66	78.74		
	No. of contacts	6	10			14	16	20																																																															
	A	12.20	17.30			22.40	24.90	30.00																																																															
	B	5.08	10.16			15.24	17.78	22.86																																																															
	No. of contacts	24	26			30	34	40																																																															
	A	35.18	37.60			42.70	47.80	55.40																																																															
	B	27.94	30.48			35.56	40.64	48.26																																																															
	No. of contacts	50	60			64																																																																	
	A	68.10	80.80			85.90																																																																	
	B	60.96	73.66			78.74																																																																	
	10	09 18 510 □ 813	09 18 510 □ 814*																																																																				
	14	09 18 514 □ 813	09 18 514 □ 814*																																																																				
	16	09 18 516 □ 813	09 18 516 □ 814*																																																																				
	20	09 18 520 □ 813	09 18 520 □ 814*																																																																				
24	09 18 524 □ 813																																																																						
26	09 18 526 □ 813	09 18 526 □ 814*																																																																					
30	09 18 530 □ 813	09 18 530 □ 814*																																																																					
34	09 18 534 □ 813	09 18 534 □ 814*																																																																					
40	09 18 540 □ 813	09 18 540 □ 814*																																																																					
50	09 18 550 □ 813	09 18 550 □ 814*																																																																					
60	09 18 560 □ 813	09 18 560 □ 814*																																																																					
64	09 18 564 □ 813	09 18 564 □ 814*																																																																					
with strain relief clamp with bulk packaging 3) Packaging unit (PU) 3,000 pieces 4) PU 2,500 pieces 5) PU 2,000 pieces 6) PU 1,500 pieces 7) PU 1,000 pieces	6	09 18 506 □ 813 58U ³⁾																																																																					
	10	09 18 510 □ 813 58U ³⁾																																																																					
	14	09 18 514 □ 813 58U ⁴⁾																																																																					
	16	09 18 516 □ 813 58U ⁴⁾																																																																					
	20	09 18 520 □ 813 58U ⁵⁾																																																																					
	26	09 18 526 □ 813 58U ⁶⁾																																																																					
	30	09 18 530 □ 813 58U ⁵⁾																																																																					
	40	09 18 540 □ 813 58U ⁷⁾																																																																					

For performance level 3 please specify digit 
 For performance level 2 please specify digit 
 S4 = 0.76 μm (30 μinch) Au or PdNi equivalent 

¹⁾ Pitch tolerance: ± 0.1
 * Not normally kept in stock

Number of contacts

6-64



Strain relief clamp/Locking lever

Identification No. of contacts Part No. Drawing Dimensions in mm

Strain relief clamp

6	09 18 506 9002
10	09 18 510 9002
14	09 18 514 9002
16	09 18 516 9002
20	09 18 520 9002
24	09 18 524 9002
26	09 18 526 9002
30	09 18 530 9002
34	09 18 534 9002
40	09 18 540 9002
50	09 18 550 9002
60	09 18 560 9002
64	09 18 564 9002

No. of contacts	A
6	12.2
10	17.3
14	22.4
16	24.9
20	30.0
24	35.18
26	37.6
30	42.7
34	47.8
40	55.4
50	68.1
60	80.8
64	85.9

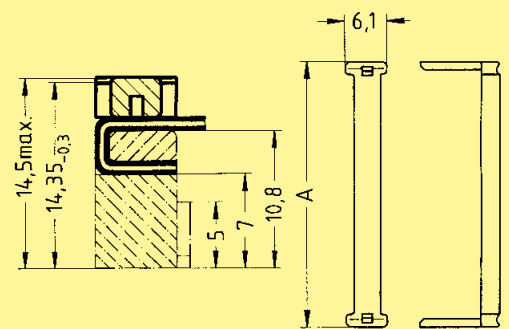

with bulk packaging

6	09 18 506 9002 58U ³⁾
10	09 18 510 9002 58U ³⁾
14	09 18 514 9002 58U ³⁾
16	09 18 516 9002 58U ³⁾
20	09 18 520 9002 58U ³⁾
26	09 18 526 9002 58U ³⁾
30	09 18 530 9002 58U ³⁾
34	09 18 534 9002 58U ⁴⁾
40	09 18 540 9002 58U ⁴⁾

6	12.2
10	17.3
14	22.4
16	24.9
20	30.0
26	37.6
30	42.7
34	47.8
40	55.4

³⁾ Packaging unit 5,000 pieces
⁴⁾ Packaging unit 3,000 pieces

Locking lever for female connector

Only in conjunction with low-profile male header and strain relief

09 18 000 9905¹⁾⁵⁾
09 18 000 9905 58U¹⁾⁶⁾

⁵⁾ Packaging unit 100 pieces
⁶⁾ Packaging unit 5,000 pieces

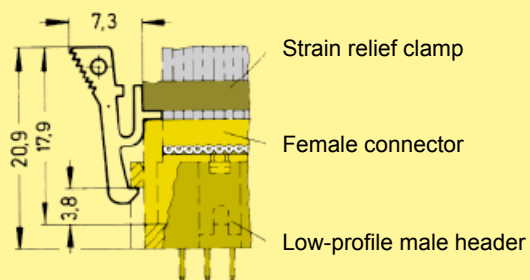

When the security of latching is required and space is a premium, these locking levers can be fitted onto the strain relief of the HARTING female connector. This can then be used in conjunction with male low-profile headers (see pages 09.14 and 09.15).

Coding system with loss of contact

Code pin

09 18 000 9901²⁾

Removal tool for male contacts

09 99 000 0133

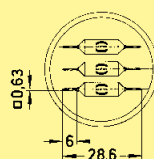

To avoid cross-plugging adjacent connectors a coding system is required. A code pin is inserted into the appropriate cavity in the female connector. The corresponding male contact is removed by a special removal tool.



¹⁾ Order 2 per female connector
²⁾ Part No. comprises 6 code pins

Number of contacts 4, 6, 8, 10, 14, 16, 20, 24, 26, 30, 34, 40, 50, 60, 64

Pitch
On pcb side: 2.54 mm [0.100"]
On cable side: 1.27 mm [0.050"]

Working current 1 A

Test voltage $U_{r.m.s.}$ 1 kV AC – 1 minute

Contact resistance 35 m Ω max.
Insulation resistance $\geq 10^9 \Omega$

Temperature range -55 °C ... + 105 °C
The maximum temperature includes heating of contacts and ambient temperature

Terminations
Solder pins:
0.635 mm x 0.3 mm
Dimensions for pcb hole:
Standard version: $\varnothing 0.9^{\pm 0.10}$ mm
Kinked version: $\varnothing 1.0^{\pm 0.05}$ mm
Diagonal: 0.71 mm
IDC flat cable
1.27 mm [0.050"] pitch: AWG 28/7

Materials
Moulding Thermoplastic resin (PBT)
UL 94-V0

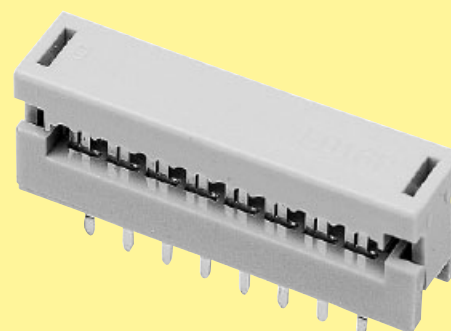
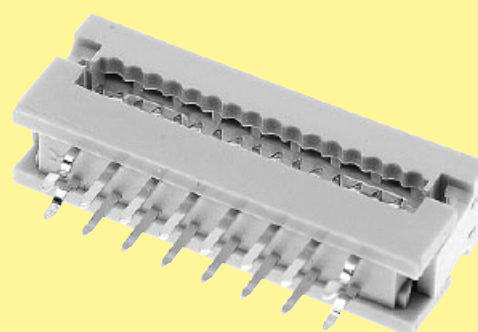

Number of contacts

4-64

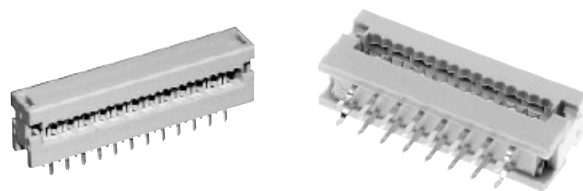

Pcb transition connector, 2 rows, low-profile with 5.5 mm height

Identification No. of contacts Part No. Drawing Dimensions in mm

Pcb transition connector²⁾
2 rows
Standard low-profile version

4	09 18 104 9622
6	09 18 106 9622
8	09 18 108 9622
10	09 18 110 9622
14	09 18 114 9622
16	09 18 116 9622
20	09 18 120 9622
24	09 18 124 9622
26	09 18 126 9622
30	09 18 130 9622
34	09 18 134 9622
40	09 18 140 9622
50	09 18 150 9622
60	09 18 160 9622
64	09 18 164 9622

No. of contacts	A ± 0.38	B ± 0.10
4	10.38	2.54 x 1 = 2.54
6	12.92	2.54 x 2 = 5.08
8	15.46	2.54 x 3 = 7.62
10	18.00	2.54 x 4 = 10.16
14	23.08	2.54 x 6 = 15.24
16	25.62	2.54 x 7 = 17.78
20	30.74	2.54 x 9 = 22.86
24	35.78	2.54 x 11 = 27.94
26	38.32	2.54 x 12 = 30.48
30	43.40	2.54 x 14 = 35.56
34	48.48	2.54 x 16 = 40.64
40	56.10	2.54 x 19 = 48.26
50	68.80	2.54 x 24 = 60.96
60	81.50	2.54 x 29 = 73.66
64	86.58	2.54 x 31 = 78.74

Pcb transition connector²⁾
2 rows
Kinked low-profile version
2 kinked pins at each extremity

4	09 18 104 9422
6	09 18 106 9422
8	09 18 108 9422
10	09 18 110 9422
14	09 18 114 9422
16	09 18 116 9422
20	09 18 120 9422
24	09 18 124 9422
26	09 18 126 9422
30	09 18 130 9422
34	09 18 134 9422
40	09 18 140 9422
50	09 18 150 9422
60	09 18 160 9422
64	09 18 164 9422

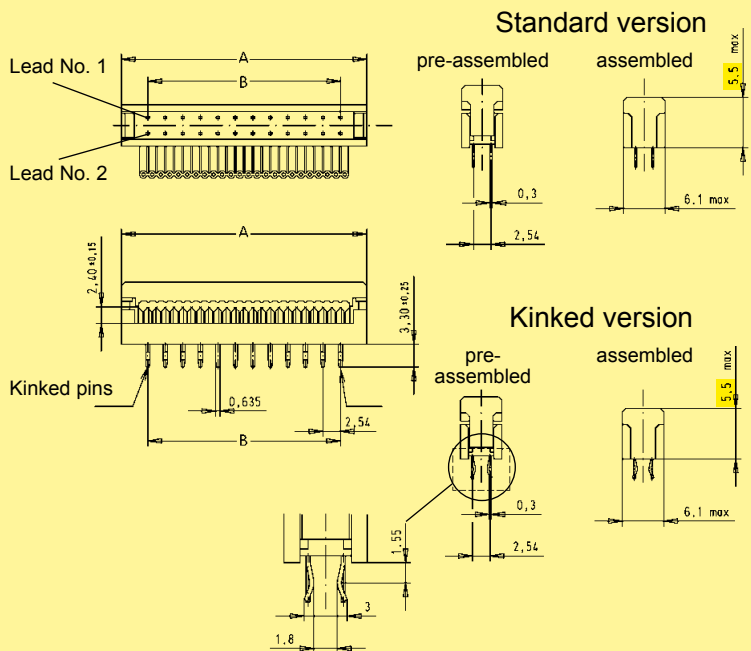

Board drillings

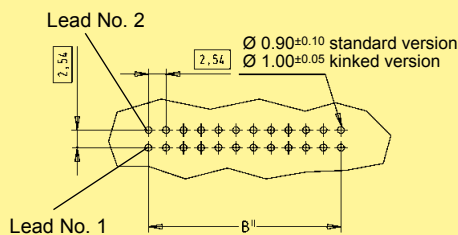

1) Pitch tolerance: ± 0.05
2) Not released for halogen free flat cables

Number of contacts* 10, 16, 20, 26, 34, 40, 50

Pitch
On pcb side: 2.54 mm [0.100"]
On cable side: 1.27 mm [0.050"]

Working current 1 A

Test voltage $U_{r.m.s.}$ 500 V

Contact resistance $\leq 20 \text{ m}\Omega$
Insulation resistance $\geq 10^{12} \Omega$

Temperature range -40 °C ... + 125 °C
The maximum temperature includes heating of contacts and ambient temperature

Terminations
Solder pins
0.45 mm x 0.35 mm
for pcb hole \varnothing 0.8 mm
Diagonal: 0.58 mm
IDC flat cable
1.27 mm [0.050"] pitch:
AWG 26/7 – AWG 28/7 – AWG 30/1

Materials
Moulding Thermoplastic resin (PC)
UL 94-V0

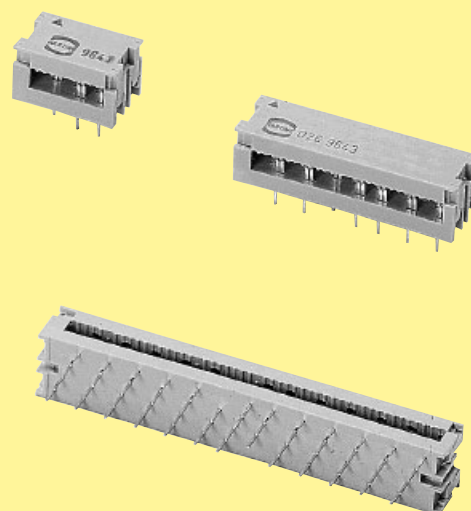

Number of contacts

10-50



Pcb transition connector, 4 rows

Identification No. of contacts Part No. Drawing Dimensions in mm

Pcb transition connector²⁾
4 rows

10	09 19 010 9643*
16	09 19 016 9643*
20	09 19 020 9643*
26	09 19 026 9643*
34	09 19 034 9643*
40	09 19 040 9643*
50	09 19 050 9643*

No. of contacts	A	B
10	17.78	1.27 x 9 = 11.43
16	25.40	1.27 x 15 = 19.05
20	30.48	1.27 x 19 = 24.13
26	38.10	1.27 x 25 = 31.75
34	48.26	1.27 x 33 = 41.91
40	55.88	1.27 x 39 = 49.53
50	68.58	1.27 x 49 = 62.23

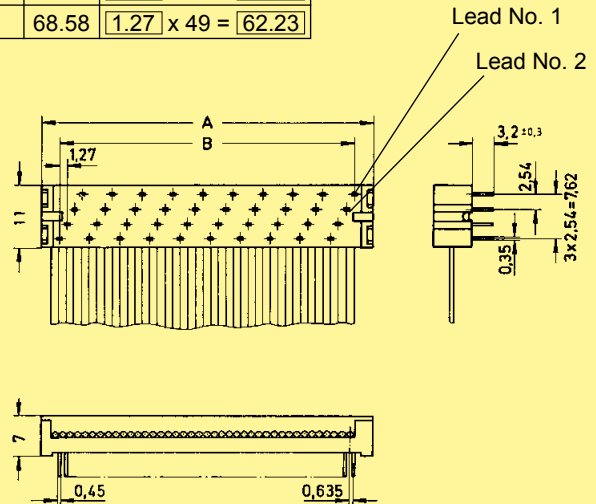

Board drillings

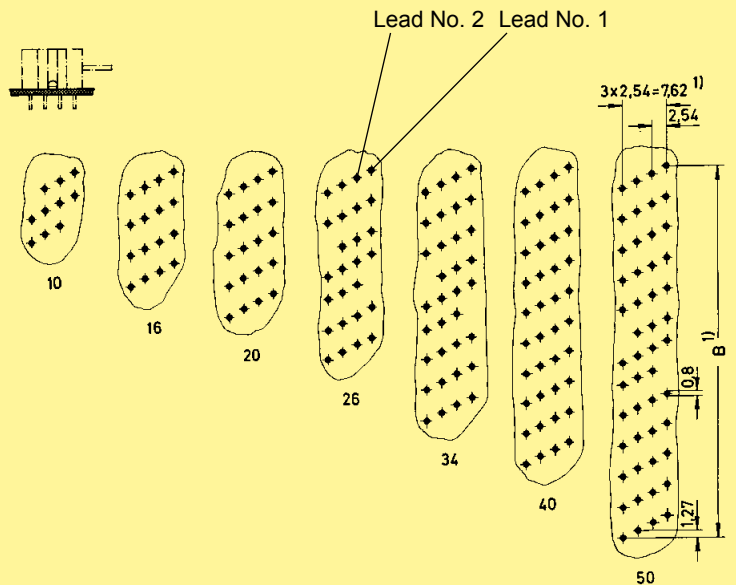

* Not normally kept in stock

¹⁾ Pitch tolerance: ± 0.1

²⁾ Not released for halogen free flat cables

Number of contacts*	14, 16, 24, 28, 40
Pitch	On pcb side: 2.54 mm [0.100"] On cable side: 1.27 mm [0.050"]
Working current	1 A
Test voltage $U_{r.m.s.}$	500 V
Contact resistance	$\leq 20 \text{ m}\Omega$
Insulation resistance	$\geq 10^{12} \Omega$
Temperature range	-40 °C ... + 125 °C The maximum temperature includes heating of contacts and ambient temperature
Terminations	Solder pins 0.45 mm x 0.35 mm for pcb hole \varnothing 0.8 mm Diagonal: 0.58 mm IDC flat cable 1.27 mm [0.050"] pitch: AWG 28/7
Materials Moulding	Thermoplastic resin (PC) UL 94-V0

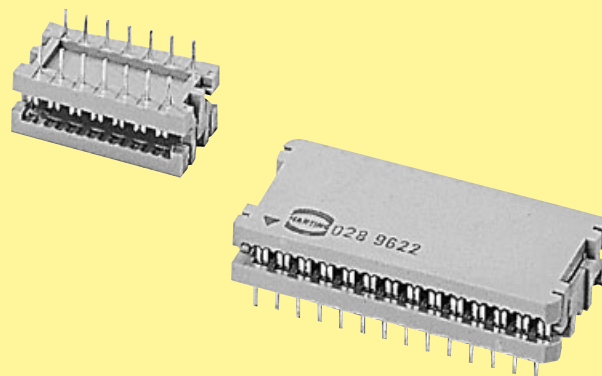

Number of contacts

14-40

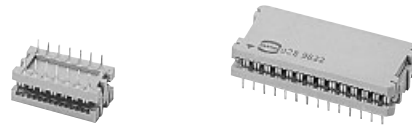

DIP connector for IC base or for soldering into pcb

Identification No. of contacts Part No. Drawing Dimensions in mm

DIP connector²⁾

14	09 17 014 9622*
16	09 17 016 9622*
24	09 17 024 9622*
28	09 17 028 9622*
40	09 17 040 9622*

No. of contacts	A	B	C	D
14	20.5	2.54 x 6 = 15.24	11	7.62
16	23.0	2.54 x 7 = 17.78	11	7.62
24	33.0	2.54 x 11 = 27.94	18.7	15.24
28	38.1	2.54 x 13 = 33.02	18.7	15.24
40	53.3	2.54 x 19 = 48.26	18.7	15.24

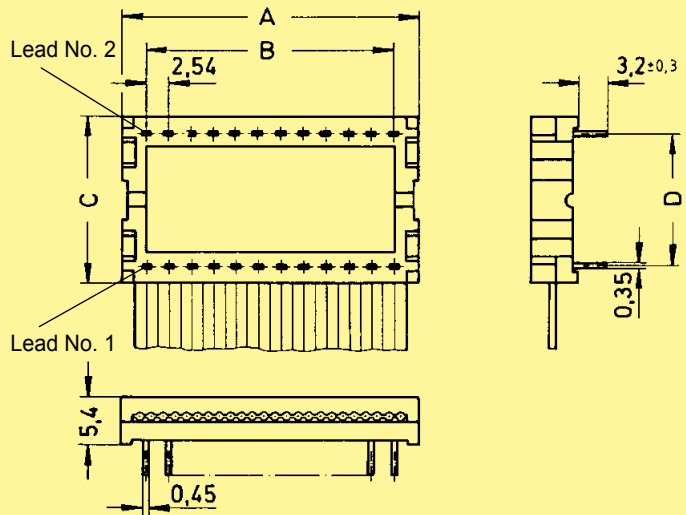

Board drillings

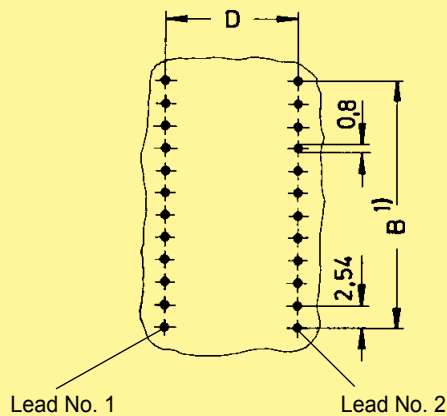
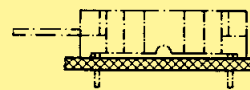

* Not normally kept in stock

¹⁾ Pitch tolerance: ± 0.1

²⁾ Not released for halogen free flat cables

Number of contacts 64

Pitch 2.54 mm [0.100"]

Working current 1 A max.

Clearance ≥ 1.2 mm
Creepage ≥ 1.2 mm

Working voltage
The working voltage also depends on the clearance and creepage dimensions of the pcb itself, and the associated wiring according to the safety regulations of the equipment

Test voltage $U_{r.m.s.}$ 1 kV

Contact resistance ≤ 20 m Ω
Insulation resistance $\geq 10^{12}$ Ω

Temperature range -55 °C ... + 125 °C
The maximum temperature includes heating of contacts and ambient temperature

Termination
Female connector Insulation displacement: AWG 28/7

Insertion and withdrawal force ≤ 60 N

Materials
Moulding Thermoplastic resin, glass-fibre filled, UL 94-V0
Contacts Copper alloy

Contact surface
Contact zone selectively plated according to performance level

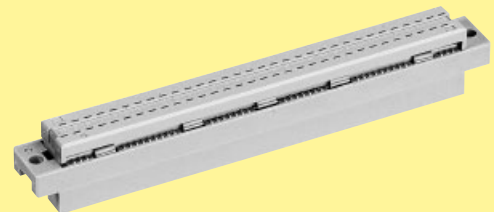
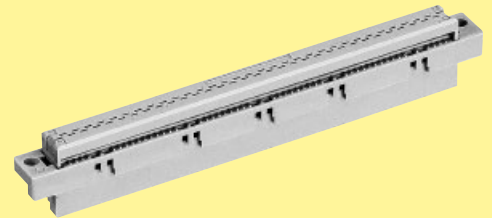

Number of contacts

64

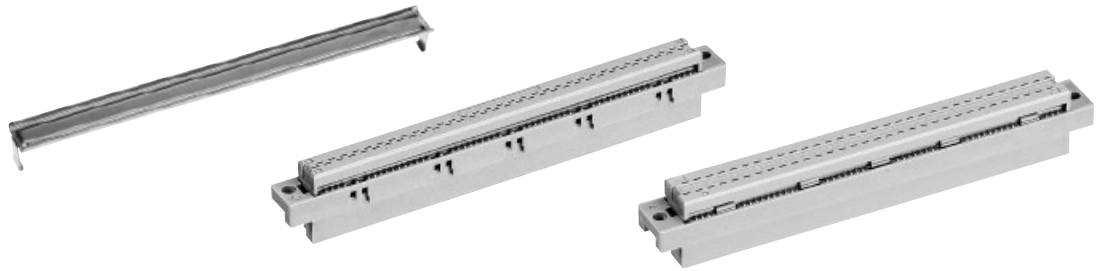

Female connectors for insulation displacement

Identification	No. of contacts	Part No.	Drawing	Dimensions in mm
----------------	-----------------	----------	---------	------------------

Female connector for insulation displacement

Type B

64

performance level 2

09 02 264 6828

performance level 3

09 02 264 7828

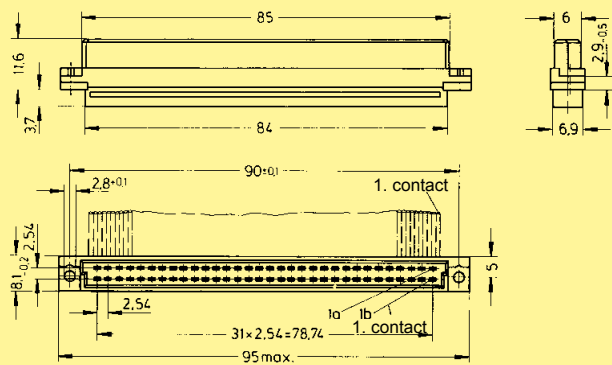

Lead number 1 of flat cable on contact 1 b

Contact arrangement View from termination side

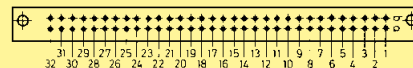

Type C

64

performance level 2

09 03 264 6828

09 03 764 6828^{c)}

performance level 3

09 03 264 7828

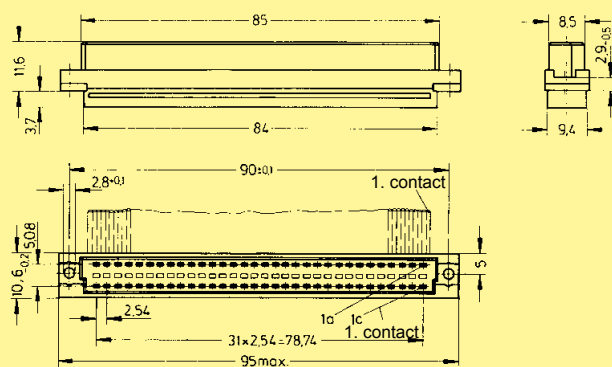

Lead number 1 of flat cable on contact 1 c

Contact arrangement View from termination side

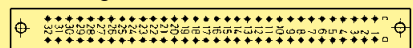

Mateable with 3-row male connector Type C.
No female contact in middle row.

Panel cut out

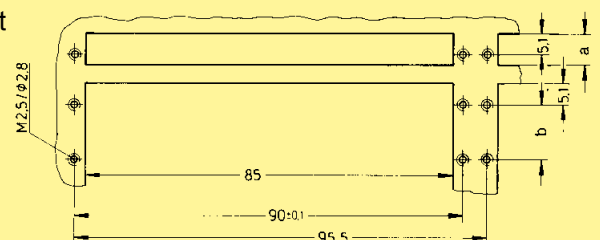

	a	b
Type B	8.3	10.16
Type C	10.8	12.7

Strain relief for types B and C

09 03 000 9940

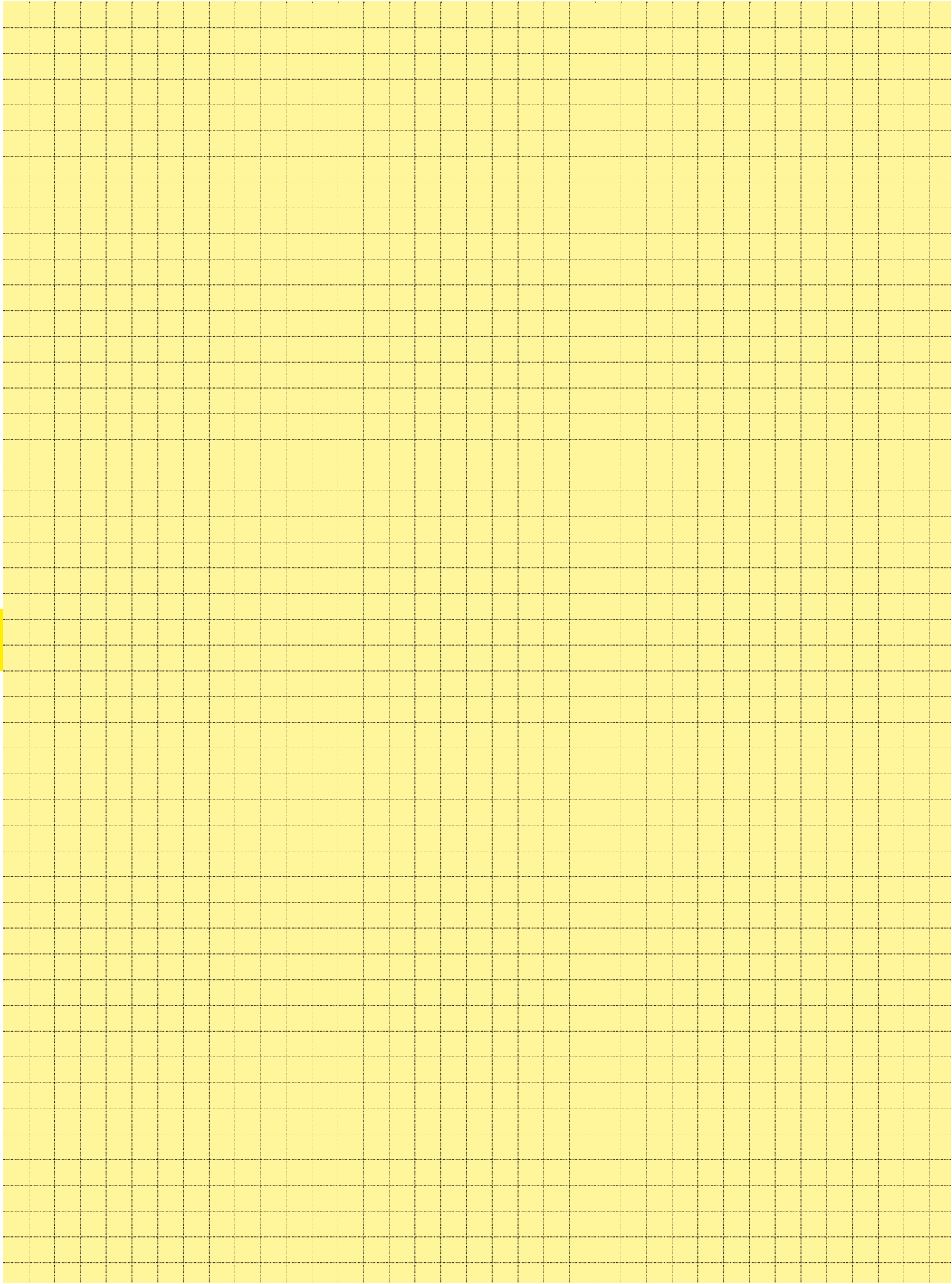

Press-in – Technology and board connectors

Page

General information **20.02**

harmik®

Technical characteristics **20.05**

I/O connectors, straight **20.06**

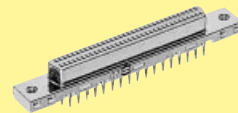

Intra cabinet connectors, straight **20.07**

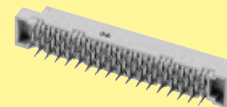

D-Sub – S

Technical characteristics **20.08**

Press-in connectors, straight **20.10**

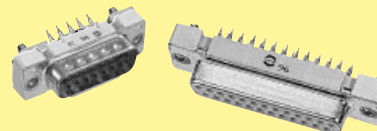

SEK

Technical characteristics for standard connectors **20.14**

Press-in connectors, straight **20.16**



Technical characteristics for low-profile connectors **20.18**

Low-profile press-in connectors, straight **20.19**



Press-in
technology

**20
01**

Solderless termination for connectors has proven to be reliable for decades. Today the use of press-in connectors encompasses all fields of electrical and electronical applications.

Pressing of electrical components, mainly connectors, is characterised through the matching of the connector pin and the plated through hole of the pcb. Whereas the desired electrical characteristics can be attained relatively independant from the design of the press-in zone, the mechanical characteristics of the press-in zone are crucial for the reliable assembly of connectors where pcb's have different surfaces.

Although the scope of requirements at the press-in process is generally defined in time-tested specifications, the novel press-in zones should offer an optimal handling and a reliable termination. Essentially, this is guaranteed through the design of the press-in zone and the meticulous observance of tolerances. HARTING has been using FEM simulations for the calculation and optimisation of press-in zones for a long period of time. This expertise allows us to simulate various pcb configurations very accurate.

Due to variety of different connector contact designs, the press-in zone has been designed to fit perfectly to the contact metal thickness and the plated through hole dimensions and tolerances.

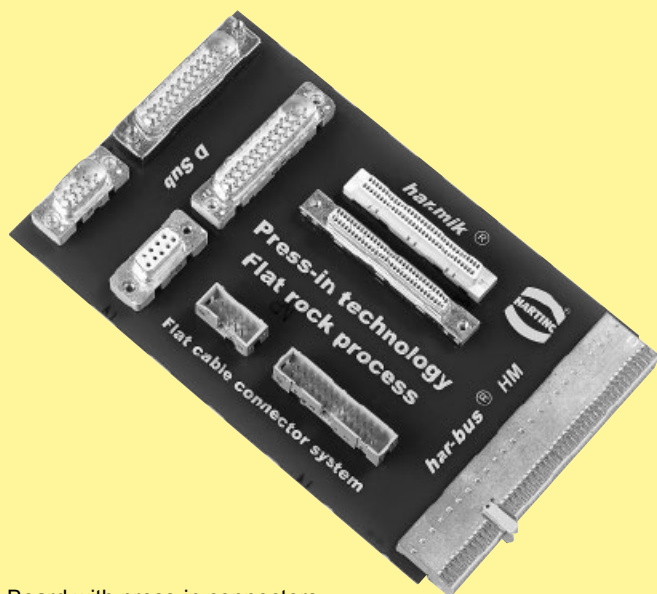

Board with press-in connectors

har-mik®

The patented contact design allows 20 % more tolerance on the plated through hole of 0.6 mm than the standard tolerance of $0.6^{+0.07}_{-0.05}$ mm.

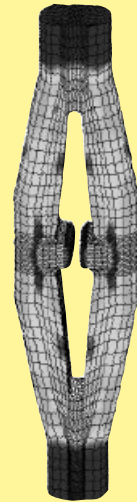

D-Sub

The terminating spoon shape of the contact provides a reliable vertical position of the connector for better alignment during insertion.

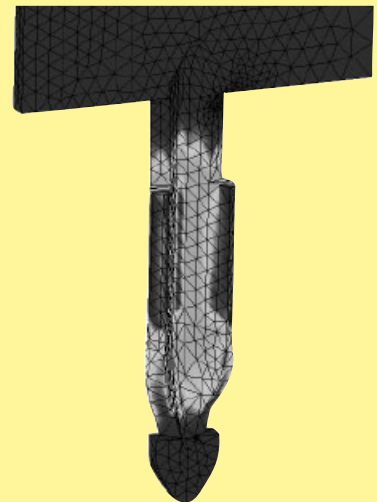

SEK

The renowned needle eye allows for compensation of tolerances of pcb surface properties. The excessive material is displaced within the plated through hole whereby a gastight connection is assured.

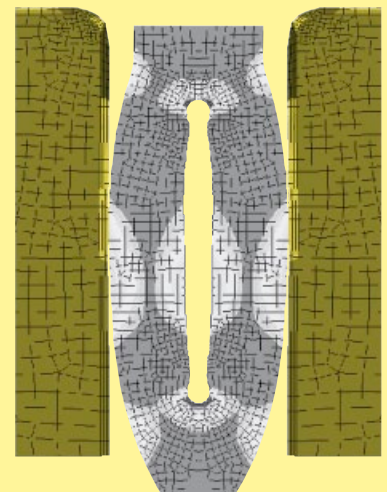

Due to the high deformation resistance and resilience of **harpress** contacts, they can be easily and repeatedly removed in case of repairs without impairment to their functioning.

Today tinned surfaces are widely used as a standard, the pcb technology trends are moving to low tin or tin free surfaces. Cu, Pd, Au and Ag are the important alternatives. Specific parameters and particularly different friction factors of these surfaces make high demands on press-in zones.

harpress is extremely versatile and offers a reliable electrical contact, therefore it is especially well suited for applications with these surfaces.

Please contact us for detailed test reports.

Benefits of the press-in technology

- Thermal shocks associated with the soldering process and the risk of the board malfunction are avoided.
- No need for the subsequent cleaning of the assembled pcb's

Recommended configuration chart for tinned plated through holes

	Plated through hole	
	0.6 mm	1 mm
Drilled hole Ø [mm]	0.71 - 0.74	1.12 - 1.15
Cu thickness [µm]	30 - 60	25 - 75
Sn thickness [µm]	5 - 20	5 - 15
Plated hole Ø [mm]	0.55 - 0.67	0.94 - 1.09
Board thickness [mm]	1.6 - 3.2	1.6 - 3.2
Connector range	har-mik	SEK and D-Sub

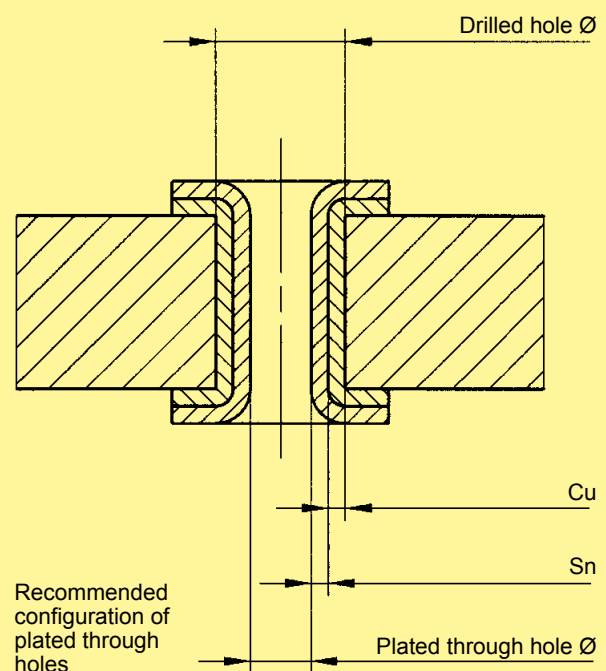
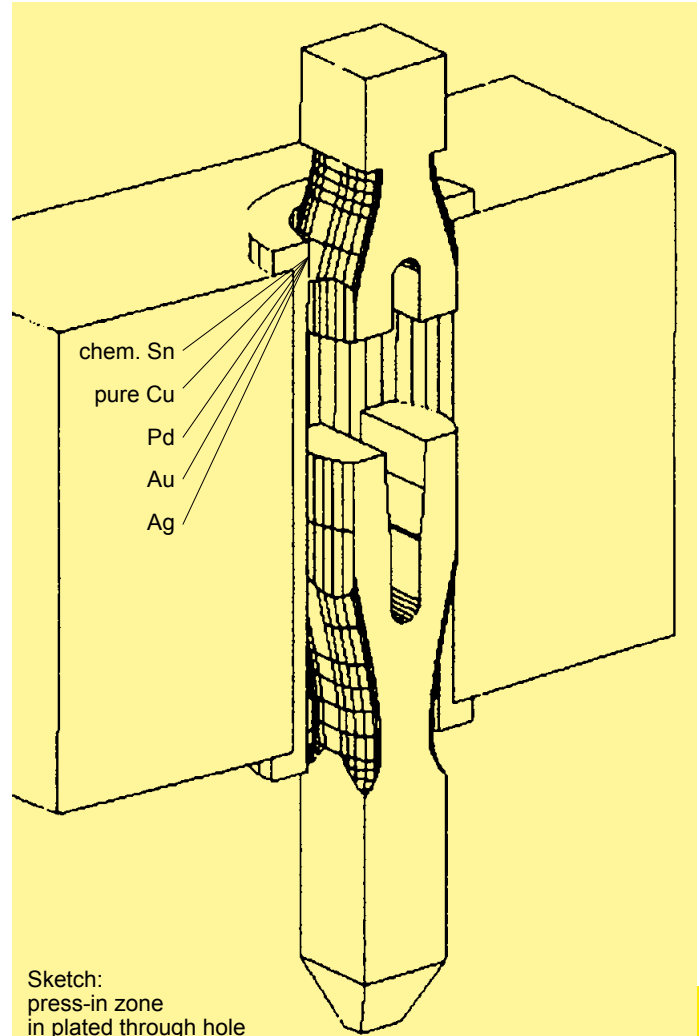

Quality control of the press-in termination

The press-in force correlates with the diameter of the plated through hole and with the friction coefficient of the surface; therefore it can be used for a continuous monitoring of the process.

The retention force, as an indirect measure of the normal force, serves to qualify the process or random tests

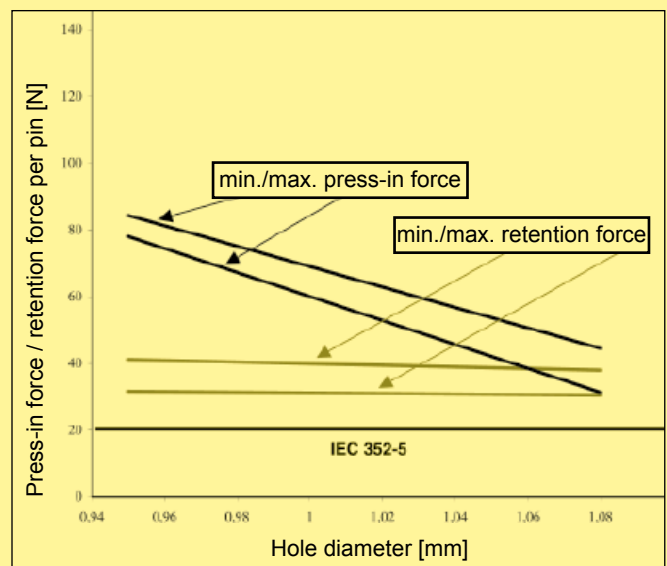

Typical press-in and retention forces for the D-Sub press-in zone

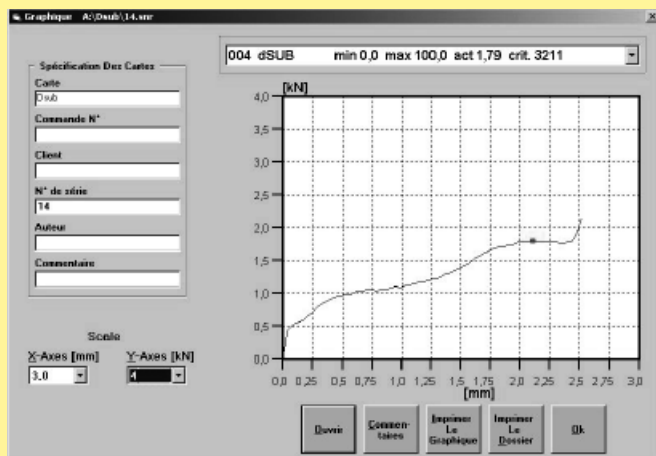

The automatic press-in machines of HARTING feature a graphical user interface for monitoring the process and the quality of the press-in termination (see chapter 30).

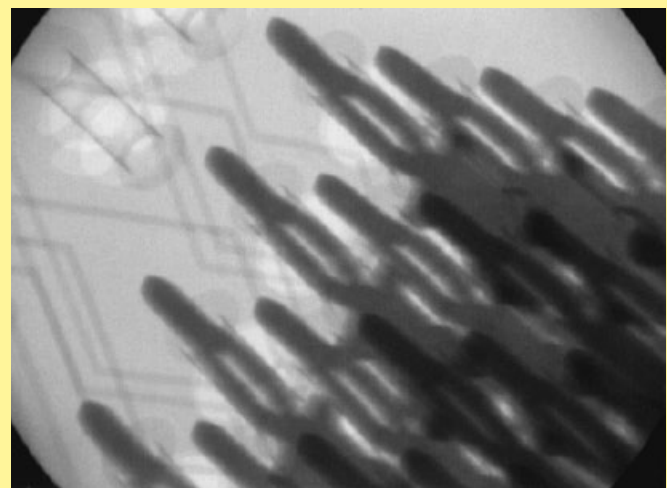

X-ray photo of a pressed-in connector

Number of contacts	68
Pitch	1.27 mm
Working current	1 A
Working voltage	240 V ~
Test voltage $U_{r.m.s.}$	750 V
Contact resistance	$\leq 30 \text{ m}\Omega$
Insulation resistance	$\geq 10^3 \text{ M}\Omega$
Temperature range	-55 °C ... + 105 °C
Materials	
Moulding	Thermoplastic resin glass-fibre filled UL 94-V0
Contacts	Copper alloy
Contact surface	
Contact zone	selectively gold-plated acc. to performance level
Metal shell	Die cast zamac or stamped steel, nickel-plated
Press-in	
Insertion process	Flat rock
Maximum press-in force per contact	100 N
Minimum push out force per contact	15 N
Number of repairs	2
Diameter of pcb plated through holes	$\text{Ø } 0.6^{+0.07}_{-0.05} \text{ mm}$
Recommended pcb holes for press-in process	Hole : $\text{Ø } 0.71 - 0.74 \text{ mm}$ Cu : 30 – 60 μm Sn : 5 – 20 μm
Pcb thickness	1.6 – 3.2 mm

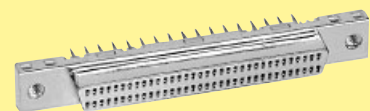

Number of contacts

68

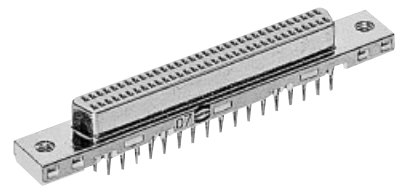

Female connectors, straight

Identification	No. of contacts	Part No.
Female connector with straight press-in pins	68	60 02 068 5322

Dimensions

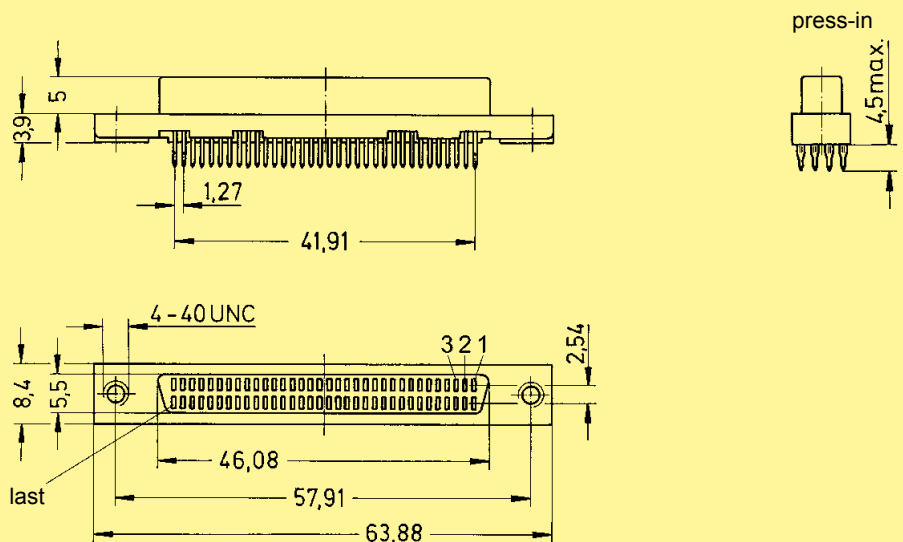

Board drillings
(Components side)

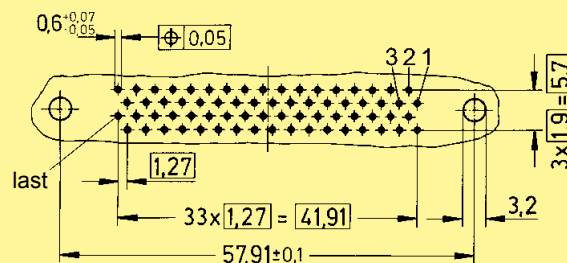

Dimensions in mm

Press-in
technology

Number of contacts

68

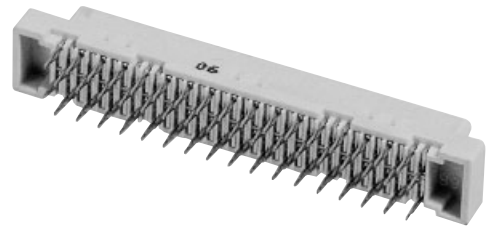

Female connectors, straight

Identification	No. of contacts	Part No.
Female connector with straight press-in pins	68	60 05 068 5322

Dimensions

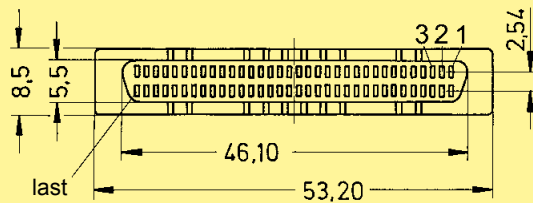
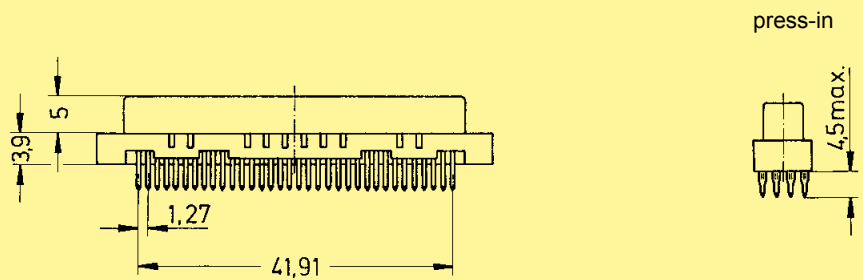

Board drillings
(Components side)

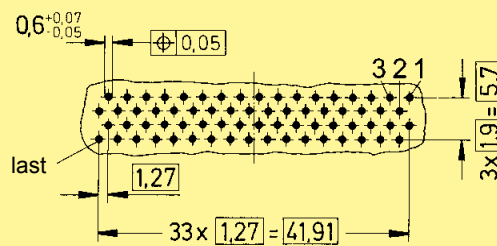

Dimensions in mm

Press-in
technology

Number of contacts	9, 15, 25, 37, 50 UL recognized
Working current	see current carrying capacity chart Stamped contacts 6.5 A max.
Test voltage $U_{r.m.s.}$	1 kV
Clearance and creepage	≥ 1.0 mm
Contact resistance	≤ 10 m Ω
Insulation resistance	$\geq 10^{10}$ Ω
Temperature range	-55 °C ... + 125 °C The higher temperature limit includes the local ambient and heating effect of the contacts under load

Terminations	Recommended PCB through holes	
	Signal pin	Grounding pin
<i>Tin-lead plated PCB</i>	Hole	1.15 ^{-0.03} 3.15 ^{±0.025}
	Cu	25-75 μ m 25-75 μ m
	Sn	5-15 μ m 4-10 μ m
	Plated hole	0.94-1.09 mm 3.0-3.15 mm
<i>Chemical tin-plated PCB</i>	Hole	1.05 ^{-0.03} 3.15 ^{±0.025}
	Cu	25-50 μ m 25-50 μ m
	Sn	0.8-1.0 μ m 0.8-1.0 μ m
	Plated hole	1.00-1.10 mm 3.0-3.15 mm
<i>Au / Ni plated PCB</i>	Hole	1.15 ^{-0.03} 3.15 ^{±0.025}
	Cu	25-50 μ m 25-50 μ m
	Ni	3-7 μ m 4-7 μ m
	Au	0.05-0.12 μ m 0.05-0.12 μ m
<i>Silver plated PCB</i>	Hole	1.15 ^{-0.03} 3.15 ^{±0.025}
	Cu	25-50 μ m 25-50 μ m
	Ag	0.1-0.3 μ m 0.1-0.3 μ m
	Plated hole	1.00-1.10 mm 3.0-3.15 mm
<i>OSP copper plated PCB</i>	Hole	1.15 ^{-0.03} 3.15 ^{±0.025}
	Cu	25-50 μ m 25-50 μ m
	Plated hole	1.00-1.10 mm 3.0-3.15 mm

PCB board thickness: ≥ 1.6 mm

Materials	
Mouldings and hoods	Liquid Crystal Polymer (LCP) UL 94-V0
Contacts	Copper alloy
Contact surface	
Contact zone	selectively plated acc. to performance level ¹⁾
Metal shell	Plated steel

Insertion and withdrawal force	
Connector on P.C.B.	
Press-in without grounding pins	
- insertion max. per contact:	120 N
- withdrawal min. per contact:	20 N
Press-in with grounding pins	
- insertion max. per grounding pin:	250 N
- withdrawal min. per grounding pin:	30 N

Mating force	9 way ≤ 30 N
	15 way ≤ 50 N
	25 way ≤ 83 N
	37 way ≤ 123 N
	50 way ≤ 167 N

Current carrying capacity

The current carrying capacity is limited by maximum temperature of materials for inserts and contacts including terminals.

The current capacity-curve is valid for continuous, not interrupted current-loaded contacts of connectors when simultaneous power on all contacts is given, without exceeding the maximum temperature.

Control and test procedures according to DIN IEC 60 512.

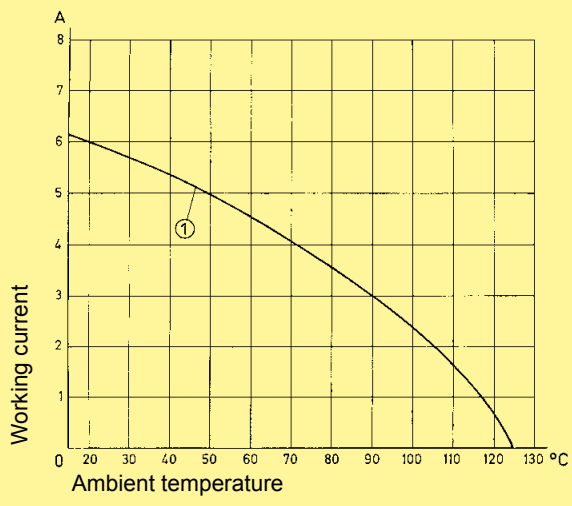

Example: 25 way connector
① Stamped contacts

Contact arrangement View from termination side

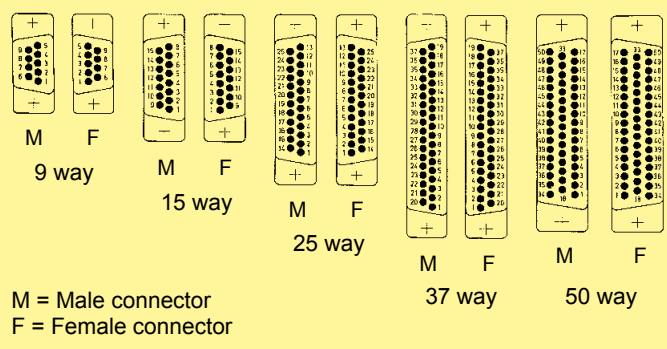

Mating conditions as per DIN 41 652

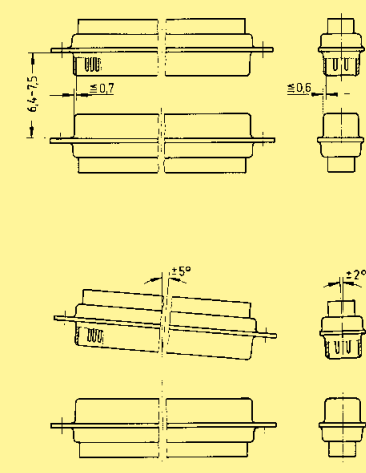

¹⁾ Performance level 3, 50 mating cycles, no gas test
Performance level 2 as per CECC 75 301-802, 250 mating cycles, 4 days 4 mixed gas test – IEC 60 512
Performance level 1 as per CECC 75 301-802, 500 mating cycles, 10 days 4 mixed gas test – IEC 60 512

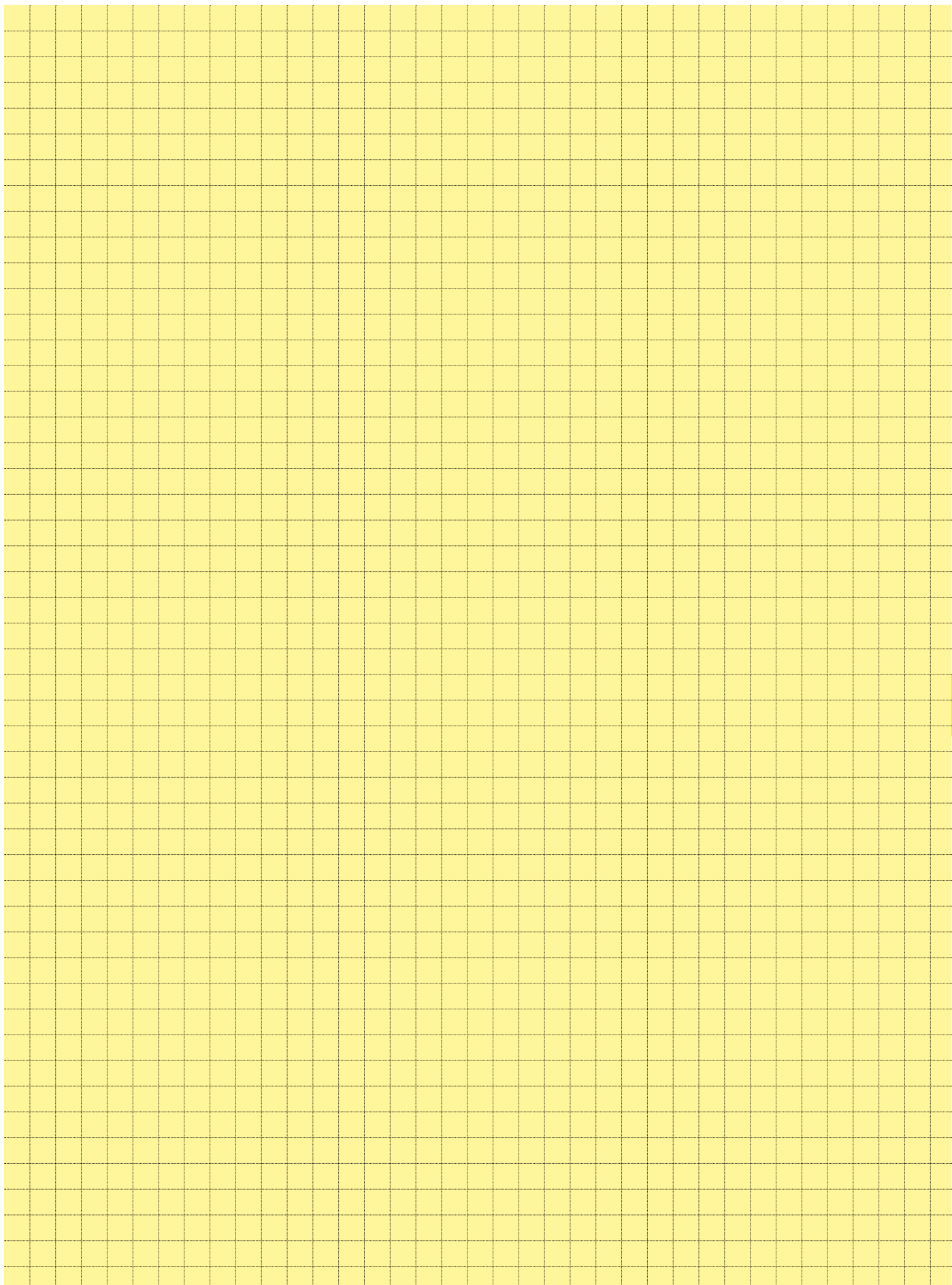

Number of contacts

9-50

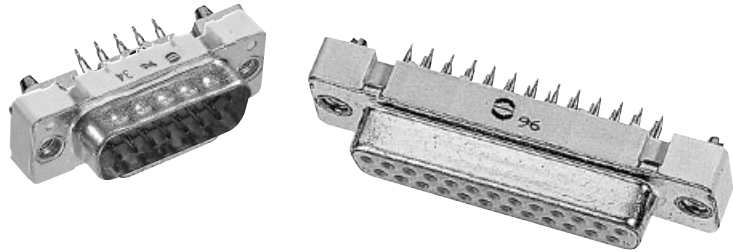

Press-in, straight with grounding press-in board locks

Identification	No. of contacts	Part No.	
Performance levels Explanations see page 20.08 Other performance levels on request		Performance level 3	Performance level 2
Male connector Flange height x = 5.7 mm			
metal shell with dimples	9 15 25	09 66 164 771 09 66 264 771 09 66 364 771	09 66 164 671 09 66 264 671 09 66 364 671
Please insert digit for flange thread or fitted female screw locks			
M3 ▶ 5 4-40 UNC ▶ 6 fitted screw locks 4-40 UNC ▶ 7 ¹⁾			
Female connector Flange height x = 5.7 mm			
metal shell	9 15 25 37	09 66 154 751 09 66 254 751 09 66 354 751 09 66 454 751	09 66 154 651 09 66 254 651 09 66 354 651 09 66 454 651
Please insert digit for flange thread or fitted female screw locks			
M3 ▶ 5 4-40 UNC ▶ 6 fitted screw locks 4-40 UNC ▶ 7 ¹⁾			
Female connector Flange height x = 6 mm			
metal shell	9 15 25 37 50	09 66 154 751 09 66 254 751 09 66 354 751 09 66 454 751 09 66 554 751	09 66 154 651 09 66 254 651 09 66 354 651 09 66 454 651 09 66 554 651
Please insert digit for flange thread or fitted female screw locks			
M3 ▶ 1 4-40 UNC ▶ 2 fitted screw locks 4-40 UNC ▶ 3 ¹⁾			

Press-in technology

20
10

¹⁾ Fitted screw locks 4-40 UNC not normally kept in stock for performance level 3
 Connector dimensions see page 20.11. Mating conditions see page 20.08.

Number of contacts

9-50

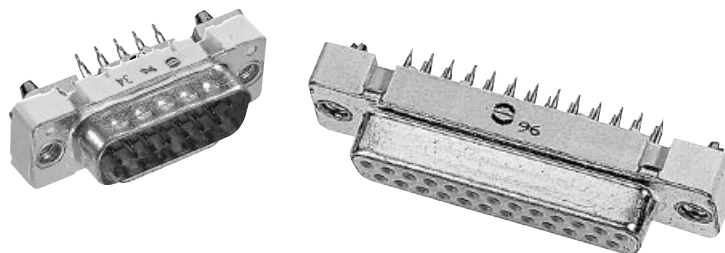

Press-in, straight with grounding press-in board locks

Identification

Drawing

Dimensions in mm

Male connector
9 – 25 contacts

M3 or
4 - 40 UNC

fitted screw locks
4 - 40 UNC

X	Y	Z
6.0 ± 0.2	4.20 ± 0.2	3.5 max.
5.7 ± 0.2	4.35 ± 0.2	3.9 max.

Female connector
9 – 37 contacts

M3 or
4 - 40 UNC

fitted screw locks
4 - 40 UNC

Mating face acc. to: DIN 41 652 · CECC 75 301-802 · IEC 60 807

	a	b	g	h
9	31.00	24.90	4 x [2.74] = 10.96	3 x [2.74] = 8.22
15	39.30	33.20	7 x [2.74] = 19.18	6 x [2.74] = 16.44
25	53.10	47.00	12 x [2.76] = 33.12	11 x [2.76] = 30.36
37	69.65	63.55	18 x [2.76] = 49.68	17 x [2.76] = 46.92
50	67.00	61.10	16 x [2.76] = 44.16	15 x [2.76] = 41.40

Female connector
50 contacts

M3 or
4 - 40 UNC

fitted screw locks
4 - 40 UNC

Board drillings

Press-in technology

Number of contacts

9-50

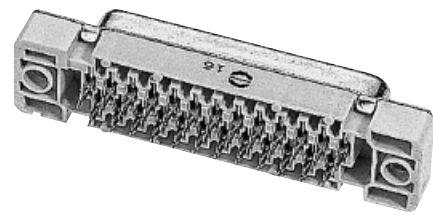
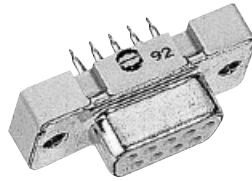

Press-in, straight without grounding press-in board locks

Identification	No. of contacts	Part No.	
Performance levels Explanations see page 20.08 Other performance levels on request		Performance level 3	Performance level 2
Male connector Flange height x = 5.7 mm			
metal shell with dimples	9 15 25	09 66 124 770 09 66 224 770 09 66 324 770	09 66 124 670 09 66 224 670 09 66 324 670
Please insert digit for flange thread or fitted female screw locks			
ø 3.1 mm hole ▶ 4 ¹⁾ M3 ▶ 5 4-40 UNC ▶ 6 fitted screw locks 4-40 UNC ▶ 7 ²⁾			
Female connector Flange height x = 5.7 mm			
metal shell	9 15 25 37	09 66 114 750 09 66 214 750 09 66 314 750 09 66 414 750	09 66 114 650 09 66 214 650 09 66 314 650 09 66 414 650
Please insert digit for flange thread or fitted female screw locks			
ø 3.1 mm hole ▶ 4 ¹⁾ M3 ▶ 5 4-40 UNC ▶ 6 fitted screw locks 4-40 UNC ▶ 7 ²⁾			
Female connector Flange height x = 6 mm			
metal shell	9 15 25 37 50	09 66 114 750 09 66 214 750 09 66 314 750 09 66 414 750 09 66 514 750	09 66 114 650 09 66 214 650 09 66 314 650 09 66 414 650 09 66 514 650
Please insert digit for flange thread or fitted female screw locks			
ø 3.1 mm hole ▶ 0 ¹⁾ M3 ▶ 1 4-40 UNC ▶ 2 fitted screw locks 4-40 UNC ▶ 3 ²⁾			

Press-in technology

¹⁾ Not normally kept in stock
²⁾ Fitted screw locks 4-40 UNC not normally kept in stock for performance level 3
 Connector dimensions see page 20.13. Mating conditions see page 20.08.

Number of contacts

9-50

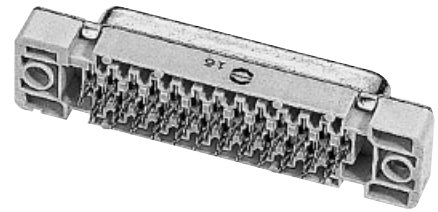
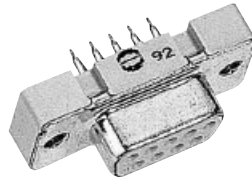

Press-in, straight without grounding press-in board locks

Identification

Drawing

Dimensions in mm

Male connector
9 – 25 contacts

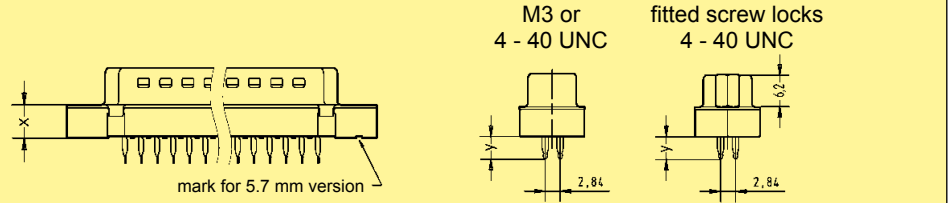

Mating face acc. to: DIN 41 652 · CECC 75 301-802 · IEC 60 807

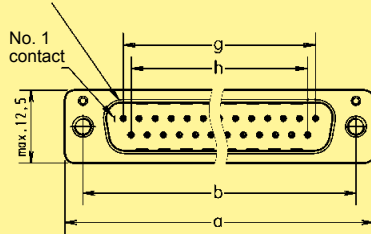

X	Y
6.0 ± 0.2	4.20 ± 0.2
5.7 ± 0.2	4.35 ± 0.2

Female connector
9 – 37 contacts

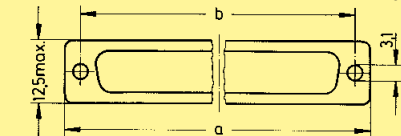
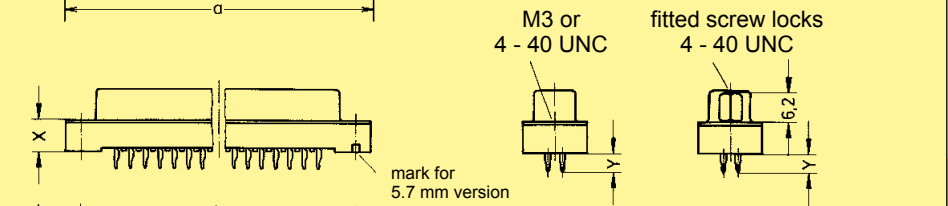

Female connector
50 contacts

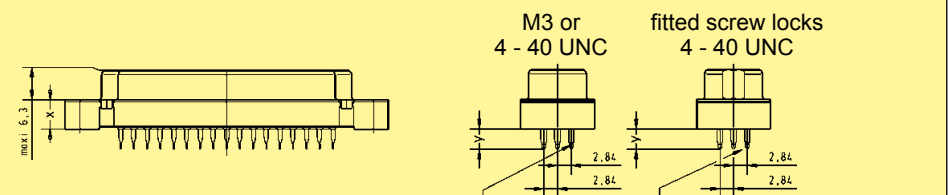

Press-in pins from position 34 to 50 are reversed 180 degrees

Mating face acc. to: DIN 41 652 · CECC 75 301-802 · IEC 60 807

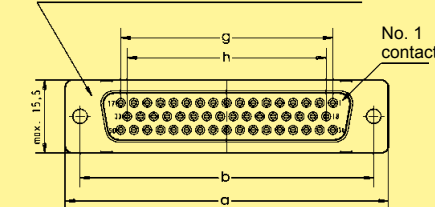

	a	b	g	h
9	31.00	24.90	4 x [2.74] = 10.96	3 x [2.74] = 8.22
15	39.30	33.20	7 x [2.74] = 19.18	6 x [2.74] = 16.44
25	53.10	47.00	12 x [2.76] = 33.12	11 x [2.76] = 30.36
37	69.65	63.55	18 x [2.76] = 49.68	17 x [2.76] = 46.92
50	67.00	61.10	16 x [2.76] = 44.16	15 x [2.76] = 41.40

Board drillings

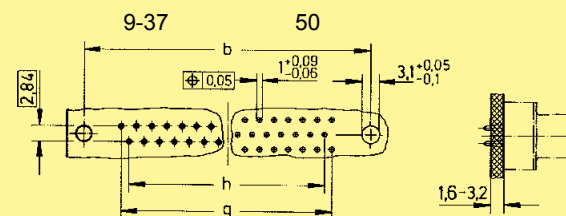

Number of contacts 10, 14, 16, 20, 26, 34, 40, 50, 60, 64

Contact arrangement straight

Contact length 4.5 mm

Approvals IEC 60603-13

Design acc. to D 2632
BT 224
BS 9525
NFC 93-428 (HE 10)

Pitch 2.54 mm [0.100"]

Working current 1 A

Working voltage 350 V DC or AC peak

Test voltage $U_{r.m.s.}$ 1 kV

Contact resistance $\leq 20 \text{ m}\Omega$
Insulation resistance $\geq 10^9 \Omega$

Temperature range $-55 \text{ }^\circ\text{C} \dots + 125 \text{ }^\circ\text{C}$
The maximum temperature includes heating of contacts and ambient temperature

Materials
Moulding PBT
UL 94-V0
Contacts Phosphor bronze

Contact surface
Contact zone plated according to performance level¹⁾

Terminations Recommended PCB through holes

<i>Tin-lead plated PCB</i>	Hole	$1.15^{+0.025}$
	Cu	min. 25 μm
	Sn	max. 15 μm
	Plated hole	0.94-1.09 mm
<i>Chemical tin-plated PCB</i>	Hole	$1.15^{+0.025}$
	Cu	min. 25 μm
	Sn	min. 0.8 μm
	Plated hole	1.00-1.10 mm
<i>Au / Ni plated PCB</i>	Hole	$1.15^{+0.025}$
	Cu	min. 25 μm
	Ni	3-7 μm
	Au	0.05-0.12 μm
	Plated hole	1.00-1.10 mm
<i>Silver plated PCB</i>	Hole	$1.15^{+0.025}$
	Cu	min. 25 μm
	Ag	0.1-0.3 μm
	Plated hole	1.00-1.10 mm
<i>OSP copper plated PCB</i>	Hole	$1.15^{+0.025}$
	Cu	min. 25 μm
	Plated hole	1.00-1.10 mm
PCB board thickness: $\geq 1.6 \text{ mm}$		

Insertion and withdrawal forces

Number of contacts	Maximum force [N]
	Performance level 1
10	20
14	28
16	32
20	40
26	52
34	68
40	80
50	100
60	120
64	128

¹⁾ Performance level 1 as per IEC 60603-13, ≥ 500 mating cycles, 10 days gas test

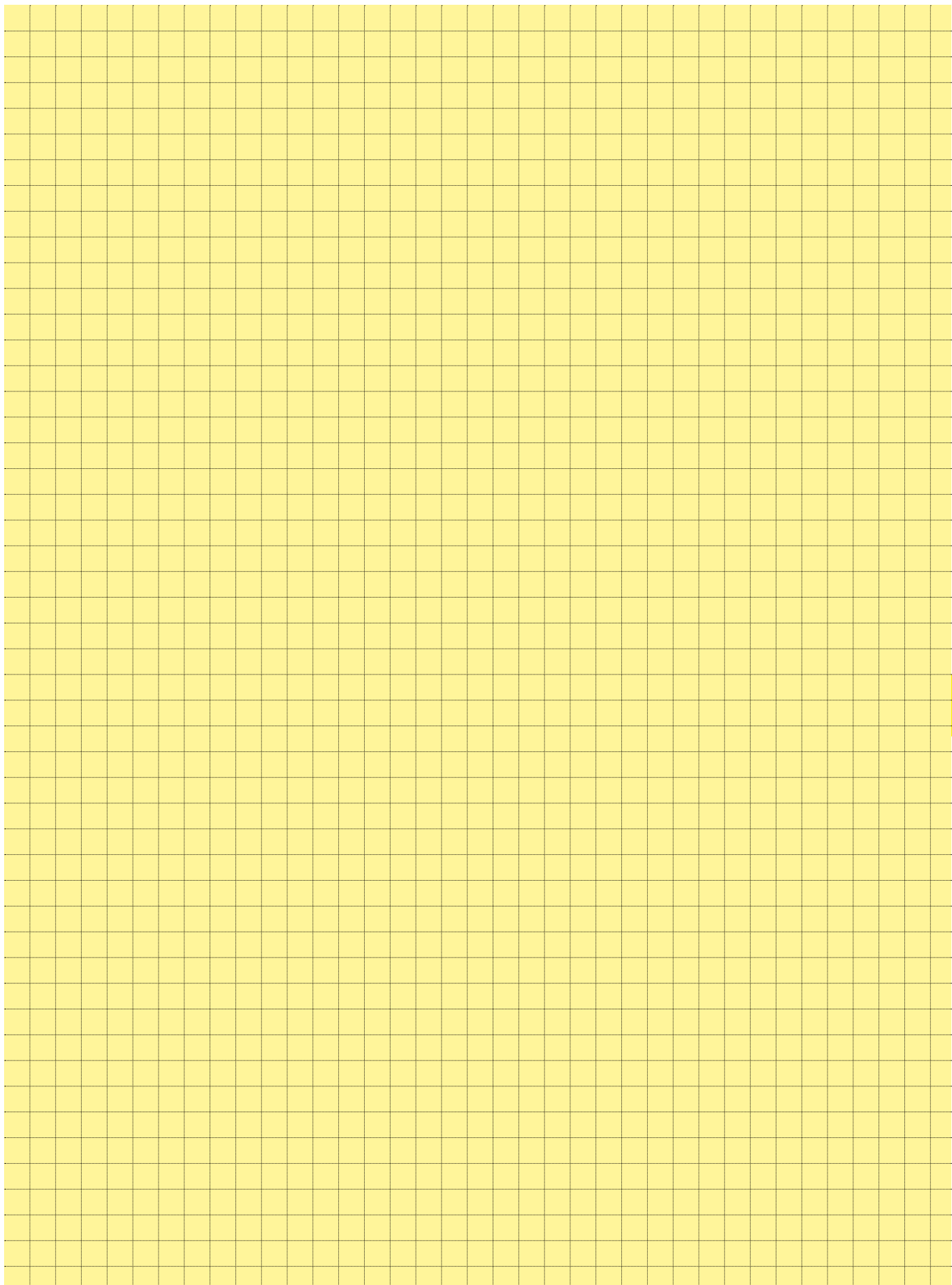

Number of contacts

10-64

Male header,
straight press-in pins

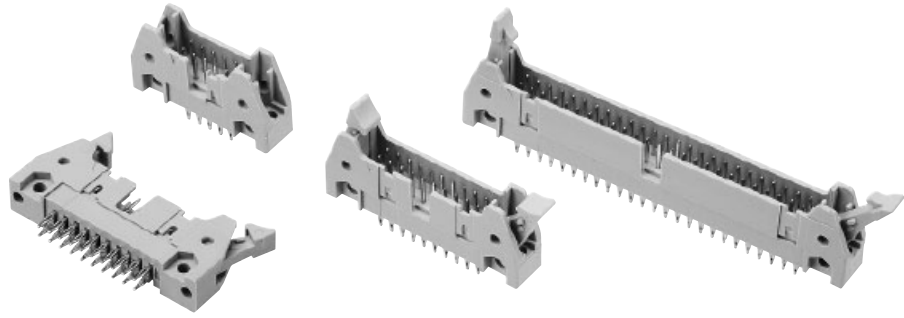

Identification	No. of contacts	Part No.		
		Without levers	With short levers	With long levers
Male header with straight press-in terminations Length: 4.5 mm				
	10	09 18 510 5929	09 18 510 5919	09 18 510 5909
	14	09 18 514 5929	09 18 514 5919	09 18 514 5909
	16	09 18 516 5929	09 18 516 5919	09 18 516 5909
	20	09 18 520 5929	09 18 520 5919	09 18 520 5909
	26	09 18 526 5929	09 18 526 5919	09 18 526 5909
	34	09 18 534 5929	09 18 534 5919	09 18 534 5909
	40	09 18 540 5929	09 18 540 5919	09 18 540 5909
	50	09 18 550 5929	09 18 550 5919	09 18 550 5909
	60	09 18 560 5929	09 18 560 5919	09 18 560 5909
	64	09 18 564 5929	09 18 564 5919	09 18 564 5909

Press-in
technology

Number of contacts

10-64

Male header,
straight press-in pins

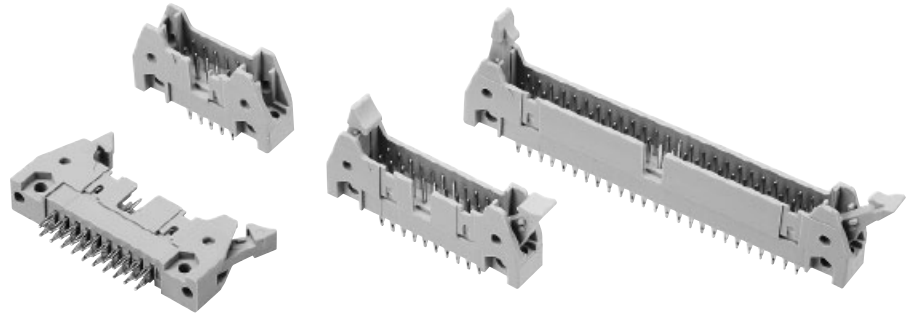

Identification

Drawing

Dimensions in mm

Male header

No. of contacts	A	C	D	E	F	G
10	32.11	21.84	17.91	2.54 x 4 = 10.16	45.11	50.11
14	37.19	26.92	22.99	2.54 x 6 = 15.24	50.19	55.19
16	39.73	29.46	25.53	2.54 x 7 = 17.78	52.73	57.73
20	44.81	34.54	30.61	2.54 x 9 = 22.86	57.81	62.81
26	52.43	42.16	38.23	2.54 x 12 = 30.48	65.43	70.43
34	62.59	52.32	48.39	2.54 x 16 = 40.64	75.59	80.59
40	70.21	59.94	56.01	2.54 x 19 = 48.26	83.21	88.21
50	82.91	72.64	68.71	2.54 x 24 = 60.96	95.91	100.91
60	95.61	85.34	81.41	2.54 x 29 = 73.66	108.61	113.61
64	100.69	90.42	86.49	2.54 x 31 = 78.74	113.69	118.69

Marking
No. 1 contact

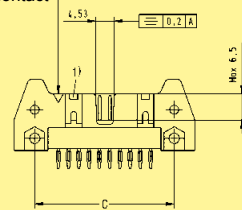

Short levers

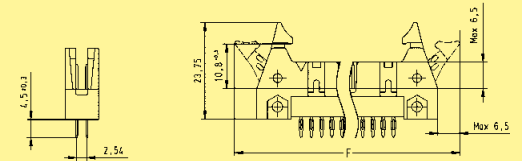

Long levers

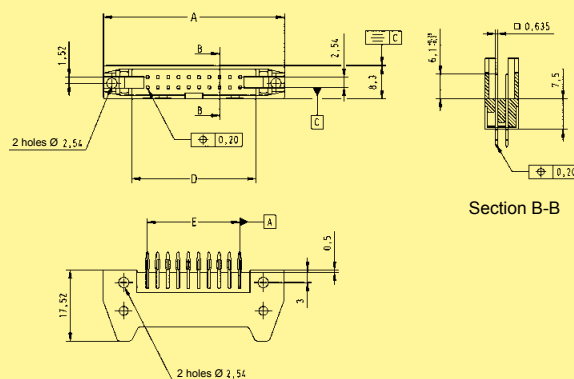

Section B-B

Board drillings

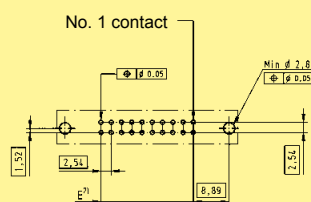

1) No polarization slot for 10 or 14 way male header

2) Pitch tolerance: ± 0.1

Number of contacts 6, 10, 14, 16, 20, 26, 34, 40, 50, 60, 64

Contact arrangement straight

Contact length 5.5 mm

Approvals IEC 60 603-13
DIN EN 60 603-13
D 2632
BT 224
NFC 93-428 (HE 10)
UL recognized: E102079



Pitch 2.54 mm [0.100"]

Working current 1 A

Test voltage $U_{r.m.s.}$ 1 kV

Contact resistance $\leq 20 \text{ m}\Omega$
Insulation resistance $\geq 10^9 \Omega$

Temperature range -55 °C ... + 105 °C
The maximum temperature includes heating of contacts and ambient temperature

Press-in

Diameter of pcb plated through holes $\varnothing 1.0^{+0.09}_{-0.06} \text{ mm}$

Recommended pcb holes for press-in process
Hole: $\varnothing 1.12 - 1.15 \text{ mm}$
Cu : 25 – 75 μm
Sn : 5 – 15 μm

Pcb thickness 1.6 – 3.2 mm

Materials

Moulding Thermoplastic resin (PBT)
UL 94-V0

Contact surface

Contact zone plated according to performance level¹⁾

Insertion and withdrawal forces

Number of contacts	Maximum force [N]	
	Performance level 1 and 2	Performance level 3
6	12	18
10	20	30
14	28	42
16	32	48
20	40	60
26	52	78
34	68	102
40	80	120
50	100	150
60	120	180
64	128	192

¹⁾ Performance level 3 as per IEC 60 603-13, ≥ 50 mating cycles, no gas test
Performance level 2 as per IEC 60 603-13, ≥ 250 mating cycles, 4 days gas test
S4, plating = 0.76 μm (30 μinch) Au or PdNi equivalent

Number of contacts

6-64

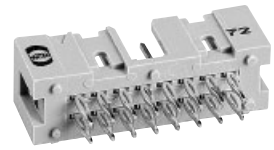

Low-profile male header, straight press-in pins

Identification No. of contacts Part No. Drawing Dimensions in mm

Low-profile male header with straight press-in terminations
Length: 5.5 mm

No. of contacts	Part No.	Drawing
6	09 18 506	329
10	09 18 510	329
14	09 18 514	329
16	09 18 516	329
20	09 18 520	329
26	09 18 526	329
34	09 18 534	329
40	09 18 540	329
50	09 18 550	329
60	09 18 560	329
64	09 18 564	329

No. of contacts	A	B	E
6	15.2	12.78	2.54 x 2 = 5.08
10	20.3	17.86	2.54 x 4 = 10.16
14	25.4	22.94	2.54 x 6 = 15.24
16	27.9	25.48	2.54 x 7 = 17.78
20	33.0	30.56	2.54 x 9 = 22.86
26	40.6	38.18	2.54 x 12 = 30.48
34	50.8	48.34	2.54 x 16 = 40.64
40	58.4	55.96	2.54 x 19 = 48.26
50	71.3	68.66	2.54 x 24 = 60.96
60	84.0	81.36	2.54 x 29 = 73.66
64	89.1	86.44	2.54 x 31 = 78.74

Marking No. 1 contact

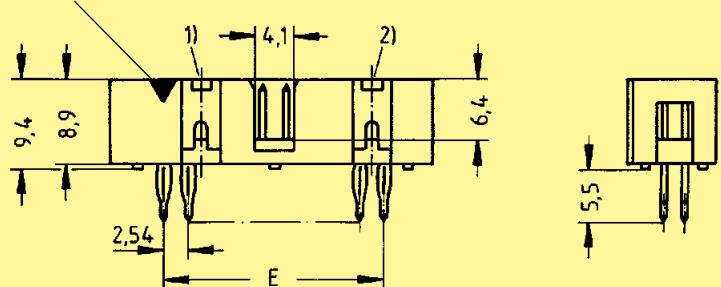

No. 2 contact

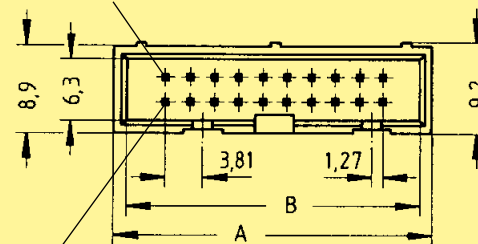

No. 1 contact

No. 2 contact

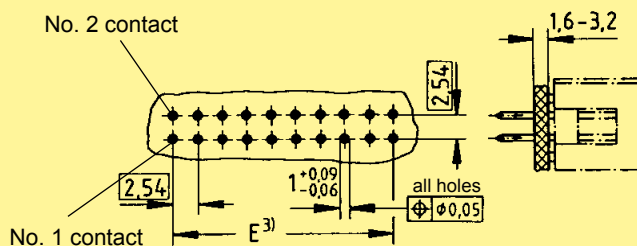

Board drillings

Press-in technology

20
19

For Performance Level 3 please specify digit 7
For Performance Level 2 please specify digit 6
S4 = 0.76 μm (30 μinch) Au or PdNi equivalent

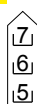

Not normally kept in stock

- 1) No polarization slot for 6, 10 or 14 way
- 2) No polarization slot for 6 way
- 3) Pitch tolerance: ± 0.1

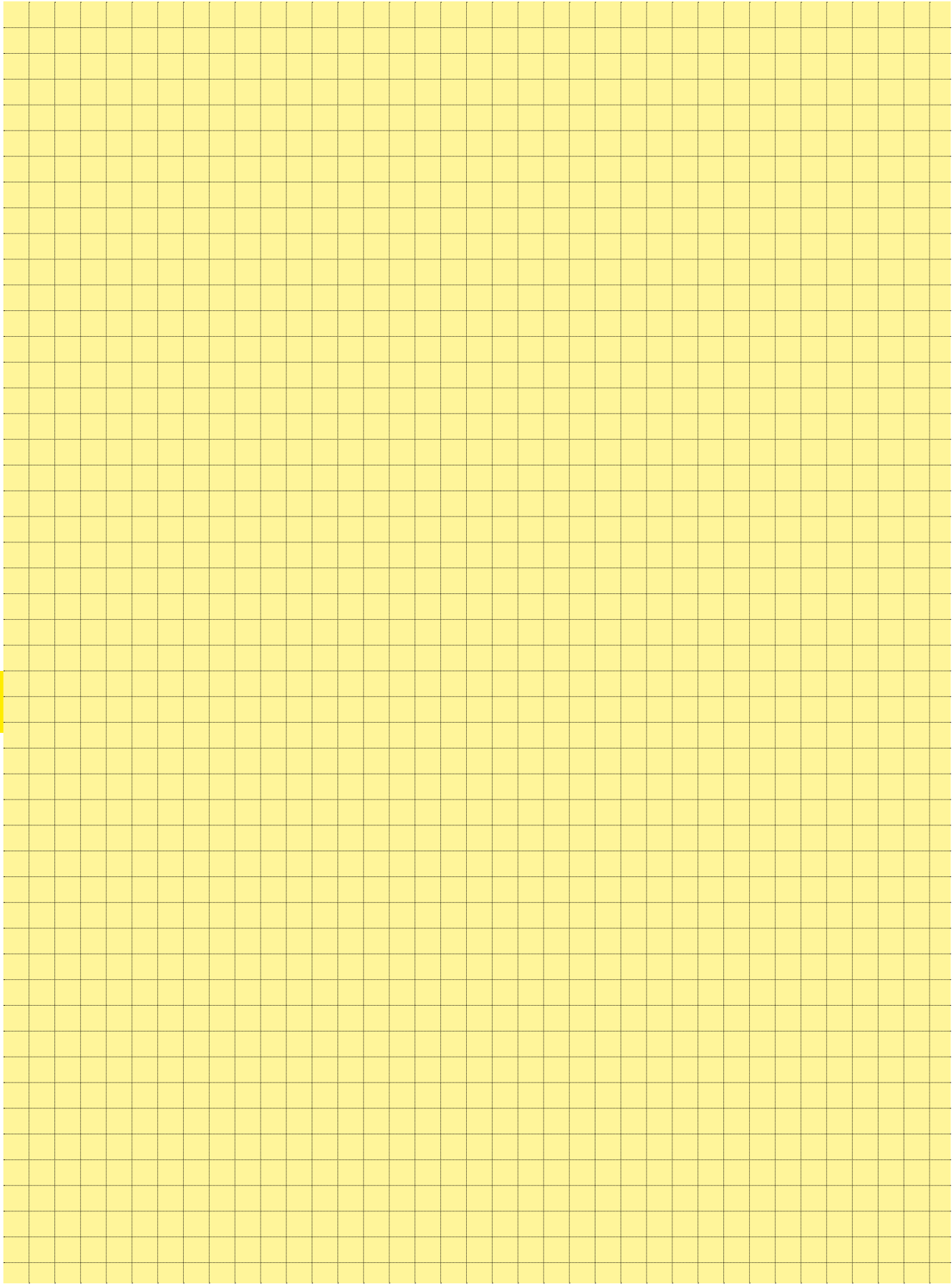

Press-in
technology

Surface Mount Technology (SMT) board connectors

Page

D-Sub – SMT

Technical characteristics **21.02**

Standard versions, angled **21.04**

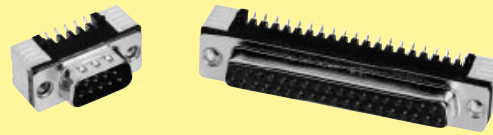

Low-profile versions, angled **21.06**



Standard versions, straight **21.08**



Number of contacts 9, 15, 25, 37

Working current 5 A

Test voltage $U_{r.m.s.}$ 1 kV

Clearance and creepage ≥ 1.0 mm

Contact resistance < 25 m Ω
Insulation resistance > 5 G Ω

Temperature range as per profile JEDEC 020 D

Terminations Solder pins for P.C.B. pads

Materials

Mouldings LCP black
UL 94-V0

Contacts Phosphorus bronze

Grounding die Zamac

Shell Steel

Contact surface

Contact zone selectively plated
acc. to performance level¹⁾

Grounding die Pure tin

Shell Nickel plated

Mating force

9 way ≤ 30 N
15 way ≤ 50 N
25 way ≤ 83 N
37 way ≤ 123 N

Contact arrangement View from termination side

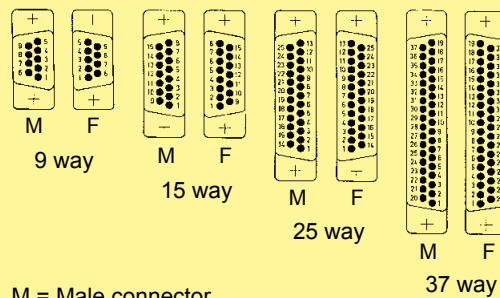

M = Male connector
F = Female connector

Mating conditions as per DIN 41 652

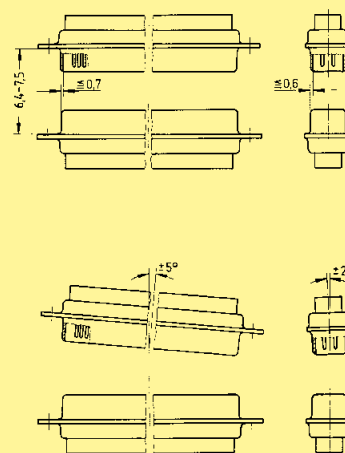

SMT technology

¹⁾ Performance level 3, 50 mating cycles, no gas test
Performance level 2 as per CECC 75 301-802, 250 mating cycles, 4 days 4 mixed gas test – IEC 60 512

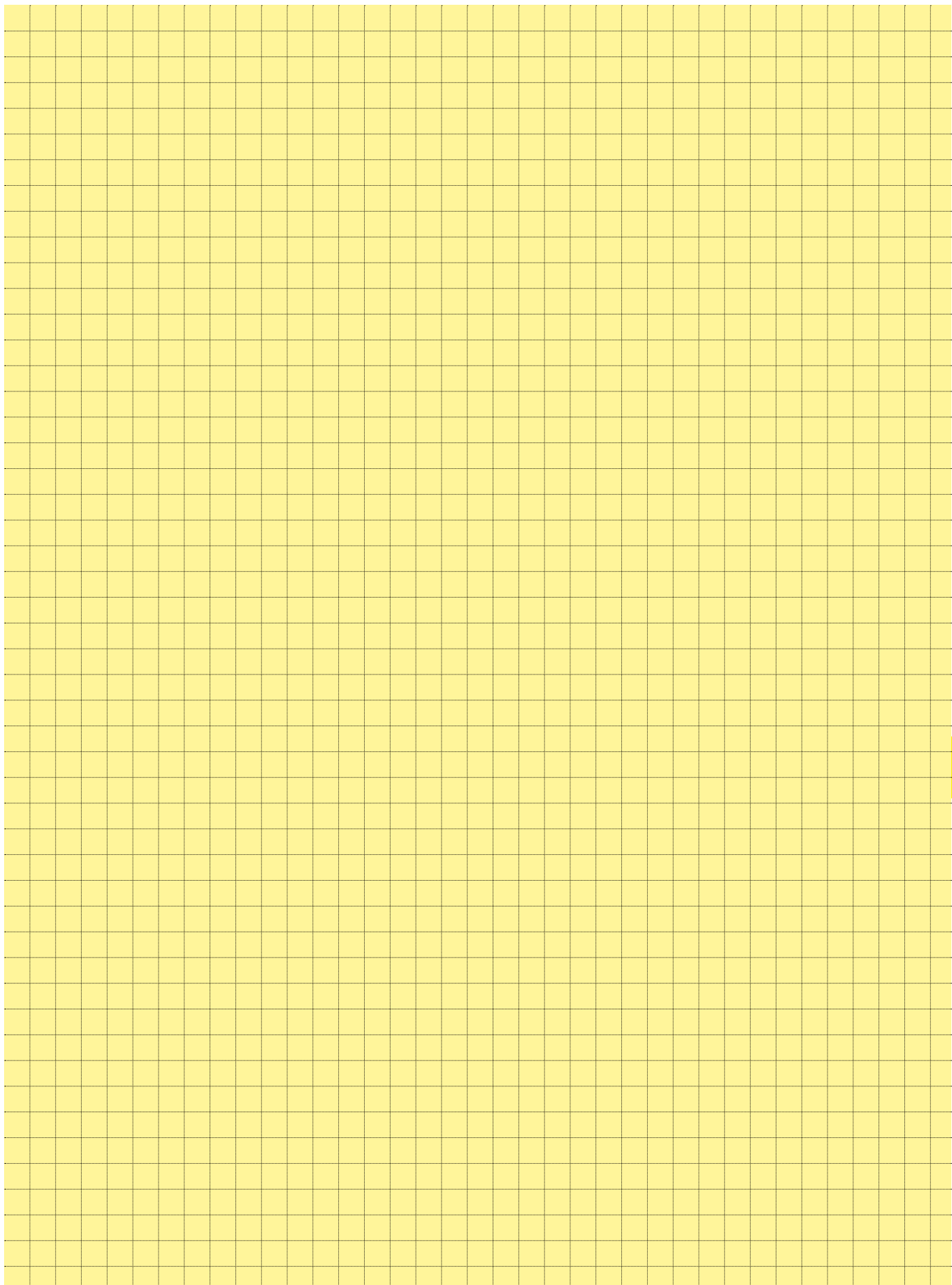

Number of contacts

9–37



SMT stamped solder pins, angled with grounding board locks

Identification	No. of contacts	Performance level 3		Performance level 2	
Performance levels Explanations see page 21.02 Other performance levels on request					
Male connector metal shell with dimples	9 15 25 37	09 55 166 78 .. 741 09 55 266 78 .. 741 09 55 366 78 .. 741 09 55 466 78 .. 741		09 55 166 68 .. 741 09 55 266 68 .. 741 09 55 366 68 .. 741 09 55 466 68 .. 741	
Female connector metal shell	9 15 25 37	09 55 156 76 .. 741 09 55 256 76 .. 741 09 55 356 76 .. 741 09 55 456 76 .. 741		09 55 156 66 .. 741 09 55 256 66 .. 741 09 55 356 66 .. 741 09 55 456 66 .. 741	
Please insert digit for flange thread or fitted female screw locks					
M3 ▶ 11 4-40 UNC ▶ 12 non-removable fitted screw locks M3 ▶ 21 non-removable fitted screw locks 4-40 UNC ▶ 22					

SMT technology

Number of contacts

9-37



SMT stamped solder pins, angled with grounding board locks

Identification

Drawing

Dimensions in mm

Male connector

M3 or 4-40 UNC

non-removable fitted screw locks M3 or 4-40 UNC

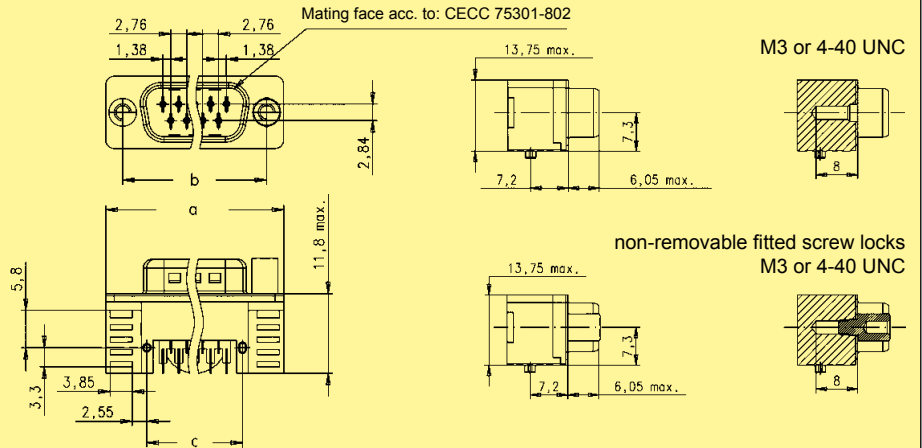

Female connector

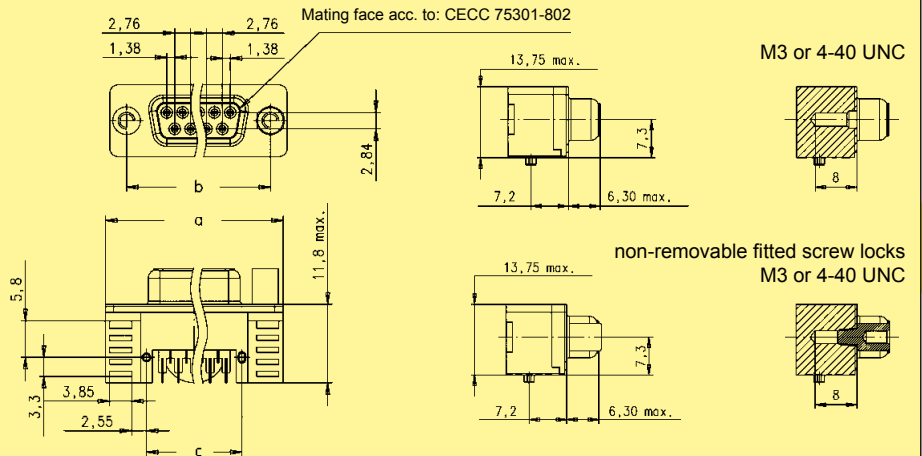

pcb layout

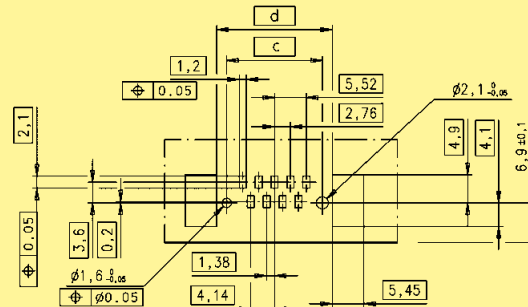

	a	b	c	d
9	31.10	24.99	16.60	20.1
15	39.52	33.32	24.90	28.4
25	53.29	47.04	38.64	42.1
37	69.60	63.50	55.10	58.6

Packaging

(1 reel = 140 pieces)
Reel diameter = 380 mm

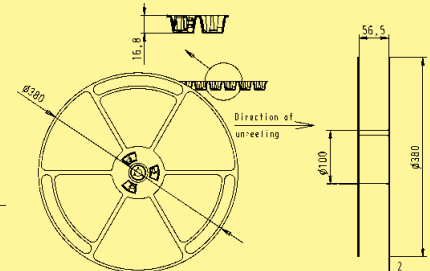
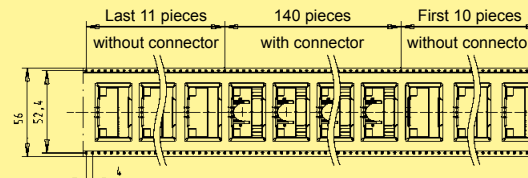

SMT technology

Number of contacts

9–37



SMT stamped solder pins, angled with grounding board locks

Identification	No. of contacts	Performance level 3		Performance level 2	
Performance levels Explanations see page 21.02 Other performance levels on request					
Male connector metal shell with dimples	9 15 25 37	09 55 166 78 .. 741 09 55 266 78 .. 741 09 55 366 78 .. 741 09 55 466 78 .. 741		09 55 166 68 .. 741 09 55 266 68 .. 741 09 55 366 68 .. 741 09 55 466 68 .. 741	
Female connector metal shell	9 15 25 37	09 55 156 76 .. 741 09 55 256 76 .. 741 09 55 356 76 .. 741 09 55 456 76 .. 741		09 55 156 66 .. 741 09 55 256 66 .. 741 09 55 356 66 .. 741 09 55 456 66 .. 741	
Please insert digit for flange thread or fitted female screw locks					
M3 ▶ 15 4-40 UNC ▶ 16 non-removable fitted screw locks M3 ▶ 19 non-removable fitted screw locks 4-40 UNC ▶ 20					

SMT technology

Number of contacts

9–37

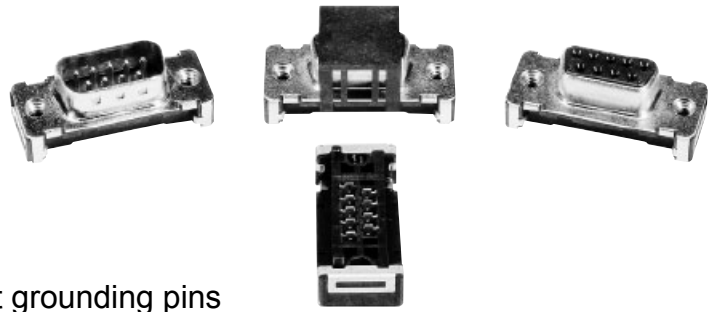

SMT stamped solder pins, straight without grounding pins

Identification	No. of contacts	Part No.	
Performance levels Explanations see page 21.02 Other performance levels on request		Performance level 3	
		Performance level 2	
Male connector metal shell with dimples			
	9	09 55 129 78 .. 741	09 55 129 68 .. 741
	15	09 55 229 78 .. 741	09 55 229 68 .. 741
	25	09 55 329 78 .. 741	09 55 329 68 .. 741
	37	09 55 429 78 .. 741	09 55 429 68 .. 741
Female connector metal shell			
	9	09 55 115 76 .. 741	09 55 115 66 .. 741
	15	09 55 215 76 .. 741	09 55 215 66 .. 741
	25	09 55 315 76 .. 741	09 55 315 66 .. 741
	37	09 55 415 76 .. 741	09 55 415 66 .. 741
Please insert digit for flange thread or fitted female screw locks			
	M3 ▶ 11		
	4-40 UNC ▶ 12		
	fixed screw locks M3 ▶ 21		
	fixed screw locks 4-40 UNC ▶ 22		

SMT
technology

D-Sub



Number of contacts

9-37

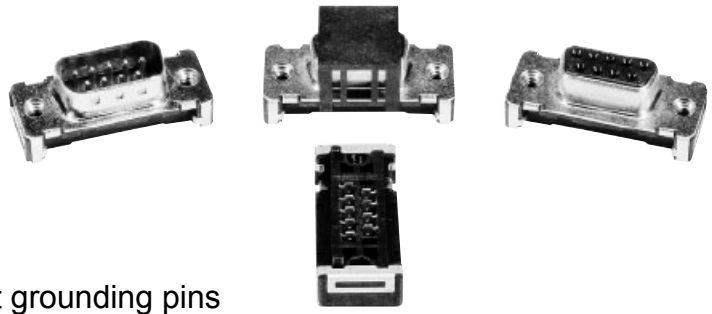

SMT stamped solder pins, straight without grounding pins

Identification

Drawing

Dimensions in mm

Male connector

M3 or 4-40 UNC non-removable fitted screw locks M3 or 4-40 UNC

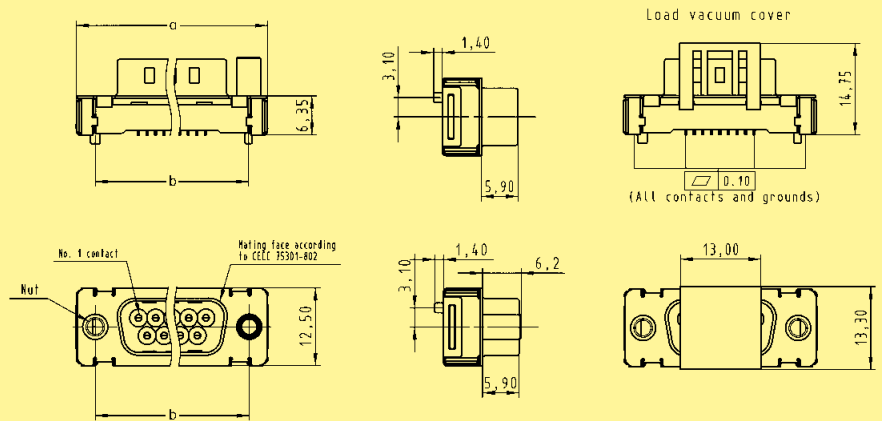

Female connector

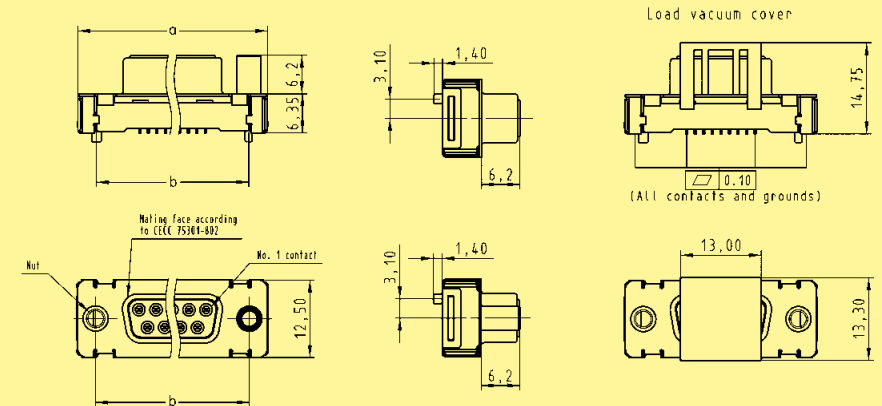

pcb layout

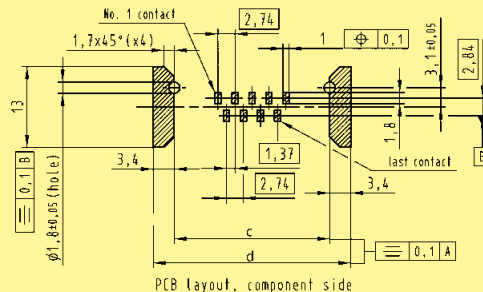

	a	b	c	d
9	31.12	25.00	25.0	31.8
15	39.45	33.33	33.3	40.1
25	53.35	47.04	47.0	53.8
37	69.62	63.50	63.5	70.3

Packaging

(1 reel = 140 pieces)
Reel diameter = 380 mm

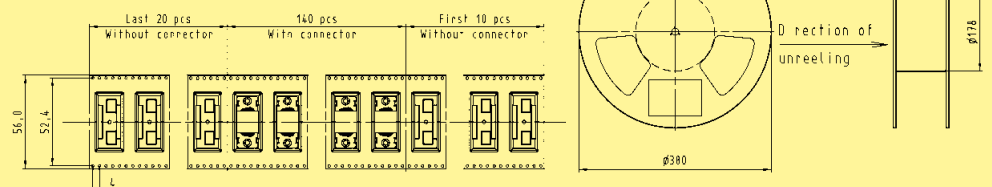

SMT technology

Number of contacts

9–37



SMT stamped solder pins, straight with grounding pins

Identification	No. of contacts	Part No.			
Performance levels Explanations see page 21.02 Other performance levels on request		Performance level 3		Performance level 2	
Male connector metal shell with dimples	9 15 25 37	09 55 169 78 .. 741 09 55 269 78 .. 741 09 55 369 78 .. 741 09 55 469 78 .. 741		09 55 169 68 .. 741 09 55 269 68 .. 741 09 55 369 68 .. 741 09 55 469 68 .. 741	
Female connector metal shell	9 15 25 37	09 55 155 76 .. 741 09 55 255 76 .. 741 09 55 355 76 .. 741 09 55 455 76 .. 741		09 55 155 66 .. 741 09 55 255 66 .. 741 09 55 355 66 .. 741 09 55 455 66 .. 741	
Please insert digit for flange thread or fitted female screw locks					
M3 ▶ 11 4-40 UNC ▶ 12 fixed screw locks M3 ▶ 21 fixed screw locks 4-40 UNC ▶ 22					

SMT technology

D-Sub



Number of contacts

9-37



SMT stamped solder pins, straight with grounding pins

Identification

Drawing

Dimensions in mm

Male connector

M3 or 4-40 UNC non-removable fitted screw locks M3 or 4-40 UNC

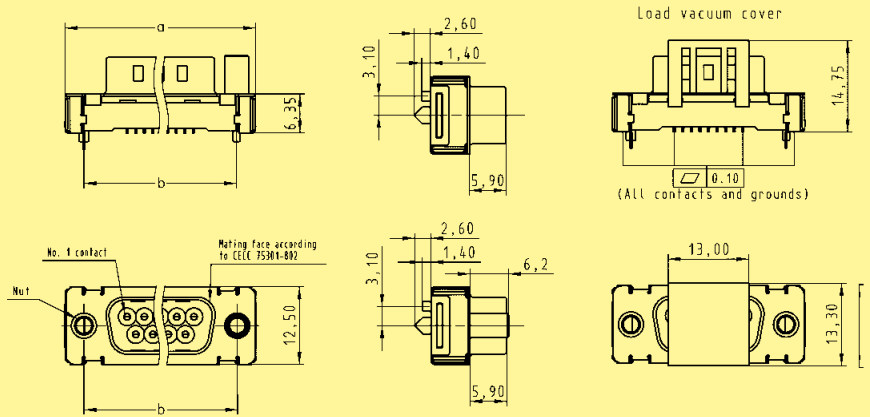

Female connector

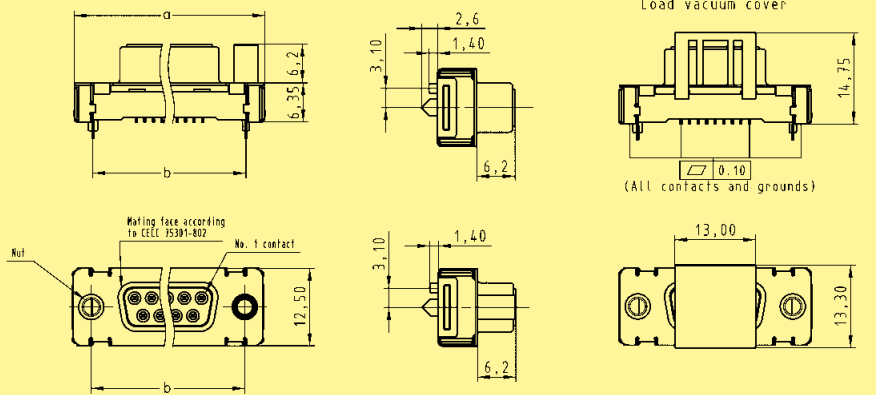

pcb layout

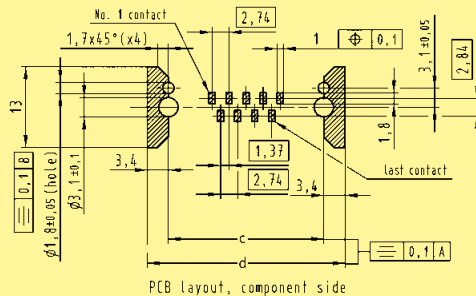

	a	b	c	d
9	31.12	25.00	25.0	31.8
15	39.45	33.33	33.3	40.1
25	53.35	47.04	47.0	53.8
37	69.62	63.50	63.5	70.3

Packaging

(1 reel = 140 pieces)
Reel diameter = 380 mm

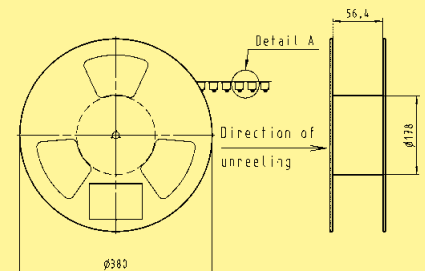
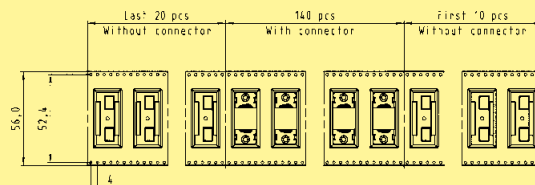

SMT technology

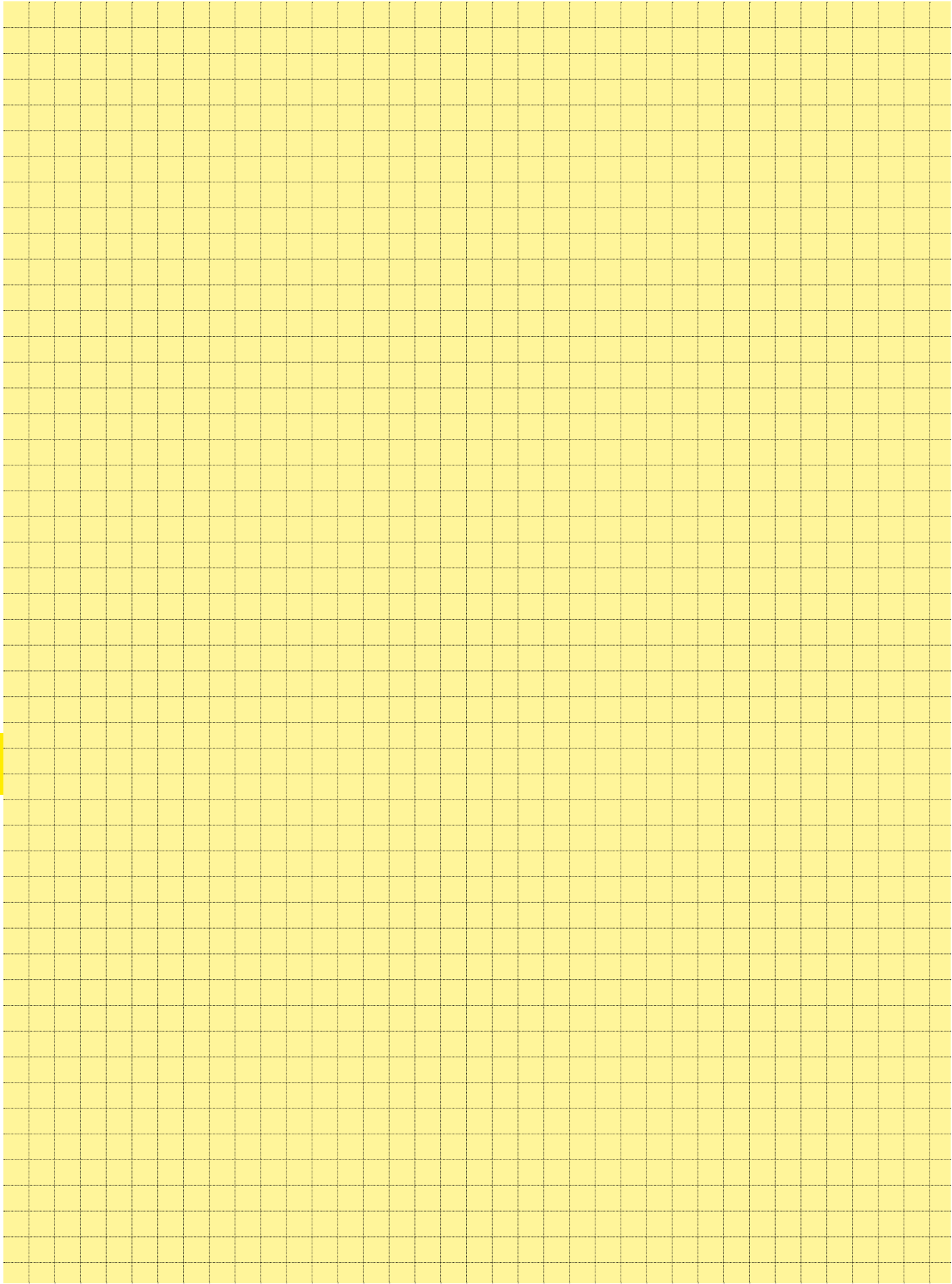

SMC* – Technology and board connectors

Page

General information **22.02**

harmik®

Technical characteristics **22.05**

Pin and socket, female connectors **22.06**

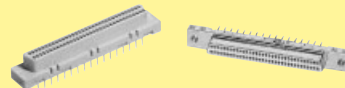

Technical characteristics **22.08**

Bellows, female connectors **22.09**

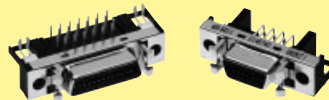

D-Sub – S

Technical characteristics **22.12**

Mounting details **22.13**

Straight versions **22.14**

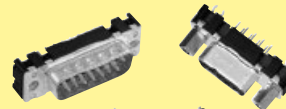

Standard versions **22.16**

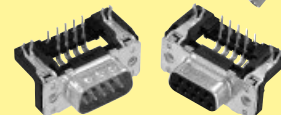

Low-profile versions **22.18**

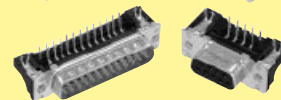

SEK

Technical characteristics **22.20**

Male standard connectors **22.22**



Male standard connectors with board lock **22.28**



Male low-profile connectors **22.30**

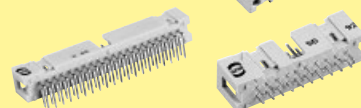

Accessories **22.32**

SMC
technology

* Also known as Pin-in-Paste or Through Hole Reflow (THR)

The continuing trend towards miniaturisation has revolutionised the assembly of electronic components. For the past 15 years, most components have been secured directly to the pcb surface by means of Surface Mount Technology (SMT). By dispensing with drilled holes on the pcb, a space saving of up to 70 percent is achieved.

Today, typical components such as ICs, resistors, capacitors, inductors, and connectors with straight terminal pins are almost exclusively fitted using SMD (Surface Mount Device) technology in mass production. In contrast, angled SMD connectors at the edge of the board have not been successful because of tolerance problems (co-planarity) and stresses during mating.

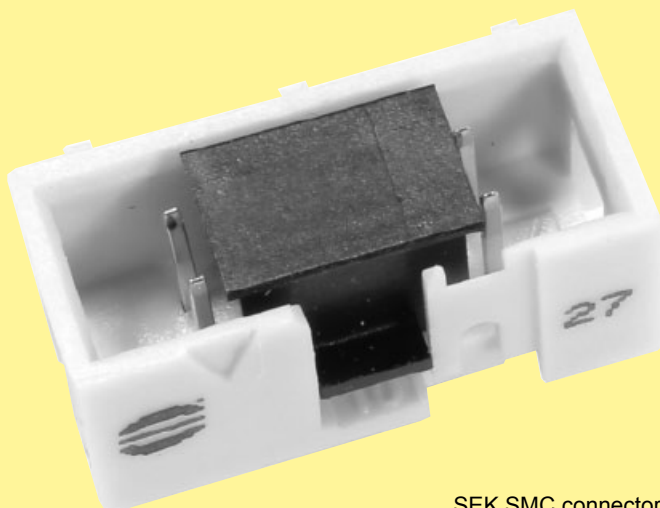

SEK SMC connector

“Pin in Hole Intrusive Reflow*”

In this process, the connector is inserted into plated through holes in a comparable way to conventional component mounting. All other components can be assembled on the pcb surface.

The components are positioned using pick-and-place machines. These automatic assembly machines differ according to whether the components are small, lightweight or bulky. Connectors, compared to ICs, are considered bulky (odd form). They are more difficult to grip, due to their comparatively heavy weight and larger size. But machines for odd form components, provide the higher insertion power, necessary to fit the components into pcb holes, which are filled with solder paste. Generally modern SMC production lines are equipped with both types of machine. Therefore the "Pin in Hole Intrusive Reflow" process entails no extra investment costs for the user.

Conventional assembly process:

1. Application of solder paste
2. Positioning the components
3. Positioning odd form components
4. Reflow soldering
5. Pressing in or partially dip soldering the connector at the board edge
6. Quality inspection

“Pin in Hole Intrusive Reflow” assembly:

1. Application of solder paste
2. Positioning the components
3. Positioning odd form components
4. Reflow soldering
5. Pressing in or partially dip soldering the connector at the board edge
6. Quality inspection

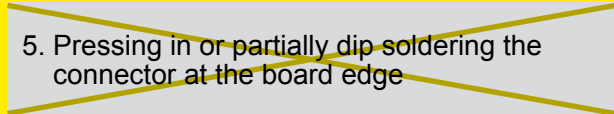

* Also known as Pin-in-Paste or Through Hole Reflow (THR)

Interface connectors were designed for Pin in Hole Intrusive Reflow with features like an inspection friendly black colour, tape and reel packaging for automated handling and it is self retaining on pcb via kinked pin. The open design – moulded from high temperature resistant material – ensures good heat distribution, so that current solder temperature profiles can be used. The special material of the insulation body withstands also the higher temperatures of lead free soldering.

Advantages for using interface connectors are:

- Partial dip soldering or press-in is no longer required
- High mechanical stability
- Complete compatibility with Surface Mount Technology
- Savings through integration into the automated assembly process
- Reduced floor space in the production plant

Application of solder paste

Before the components are assembled, solder paste is applied to all the solder pads and the plated through holes. Usually a screen printing process is used for this purpose. A squeegee moves across the pcb, which is masked with screens and presses the solder paste into all unmasked areas. A good solder joint is basically determined by the amount of the applied solder paste. Only a few parameters (illustrated on the right) will lead to the right quantity.

As an alternative to screen printing, the solder paste can be applied by means of a dispenser. A high-precision robot moves the dispenser to all required positions on the pcb. The dispensing method is particularly suitable for small pcb's or applications which demand high precision and flexibility in dispensing volumes.

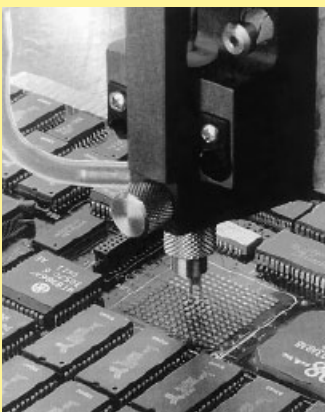

Dispenser in operation

Solder paste volume

There are numerous scientific studies dealing with calculation of the required quantity of solder paste. These studies use various parameters, e.g. the shrinking factor of the paste during soldering or the thickness of the screens used for masking the pcb. Since such calculation methods are complicated to apply, the following rule of thumb has proved valuable in practice:

$$V_{\text{Paste}} = 2(V_H - V_P)$$

in which:

V_{Paste} = Required volume of solder paste

V_H = Volume of the plated through hole

V_P = Volume of the connector termination in the hole

Comment: the multiplier "2" compensates for solder paste shrinkage during soldering. For this purpose, it was assumed that 50 % of the paste consists of the actual solder, the other 50 % being soldering aids.

Requirements for the solder connection

At the beginning of a new production batch, the process parameters, such as quantity of solder paste and soldering temperature, can be set by interpreting simple cross-sections of the soldered connection. A reliable measure for achieving optimum parameters is the quantity of solder required to fill the hole. In soldered connections of high quality, the holes are filled to between 75 % and 100 %.

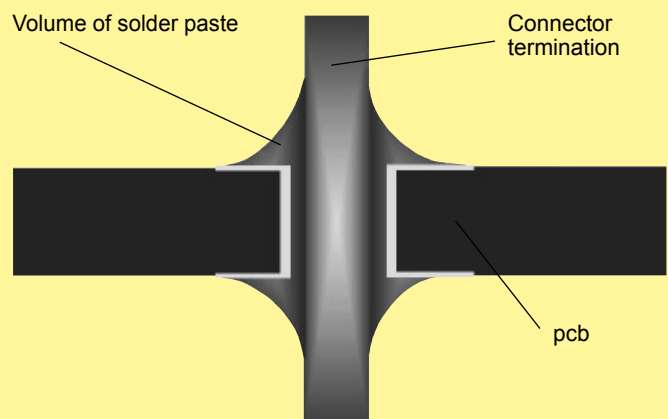

Plated through hole with connector termination

SMC connectors

SMC (Surface Mount Compatible) connectors have to withstand temperatures of up to 225°C in the reflow oven for 10 to 15 seconds. Therefore, the moulding must be made from a dimensionally stable plastic which expands at the same rate as the pcb material when subjected to heat.

The length of the connector contacts should be such that they protrude by no more than 1.5 millimetres after insertion to the pcb. Each contact collects solder on its tip as it penetrates the solder paste in the hole. So if the contact was too long, this solder would no longer be able to reflow back into the plated through hole by capillary action during the soldering process, therefore the quality of the soldered connection would suffer as a result.

Connector design must permit both automatic assembly with pick-and-place machines and manual positioning for test and pre-production batches. It is also important for the packaging of the connectors to be suitable for automated assembly. Experience shows that deep-drawn film and reel packaging fed into the pick-and-place machines with the aid of a conveyor system is particularly suitable.

HARTING SMC technology

HARTING offers its customers a complete system concept for integrating SMC technology into existing production lines. We manufacture a wide range of SMC connectors (3 and 5 row) in compliance with IEC 60603-2, D-Sub connectors in compliance with CECC 75301-802 and connectors from the har-mik® series with contact spacing of 1.27 millimetres. In addition, HARTING supports the market with packaging and processing concepts, which have been developed in collaboration with renowned manufacturers of SMC soldering and assembly plants.

You will find more detailed information in our SMC catalogue, as well as in our hard metric connectors catalogue.

Advantages of the “Pin in Hole Intrusive Reflow” process:

- Partial dip soldering or press-in is no longer required
- Complete compatibility with Surface Mount Technology
- Complete integration into the automated assembly process
- Reduced floor space in the production plant
- As a rule, no additional investment costs



SEK connector mounted in a tape ready for placement using an odd form assembly station.

Number of contacts	68
Pitch	1.27 mm
Working current	1 A
Working voltage	240 V ~
Test voltage $U_{r.m.s.}$	750 V
Contact resistance	$\leq 30 \text{ m}\Omega$
Insulation resistance	$\geq 10^3 \text{ M}\Omega$
Temperature range during reflow soldering	-55 °C ... + 105 °C max. + 240 °C for 60 s
Terminations	
Solder pins	Straight for pcb holes min. $\varnothing 0.74 \text{ mm}$
Materials	
Moulding	Thermoplastic resin glass-fibre filled UL 94-V0 Liquid Crystal Polymer (LCP)
Contacts	Copper alloy
Contact surface	
Contact zone	Selectively gold plated according to performance level
Metal shell	Die cast zamac or stamped steel, nickel-plated

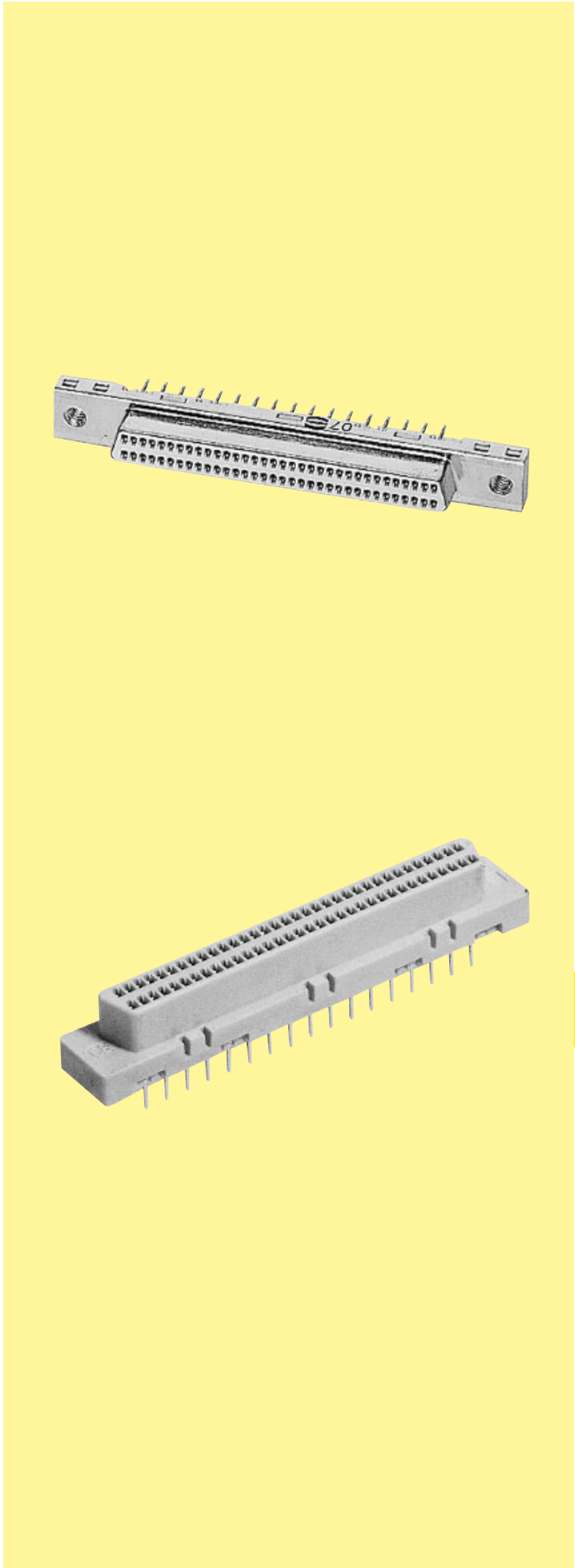

Number of contacts

68

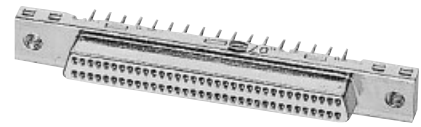

SMC female connectors, straight

Identification	No. of contacts	Part No.
SMC female connector with straight solder pins	68	60 02 068 5120

Dimensions

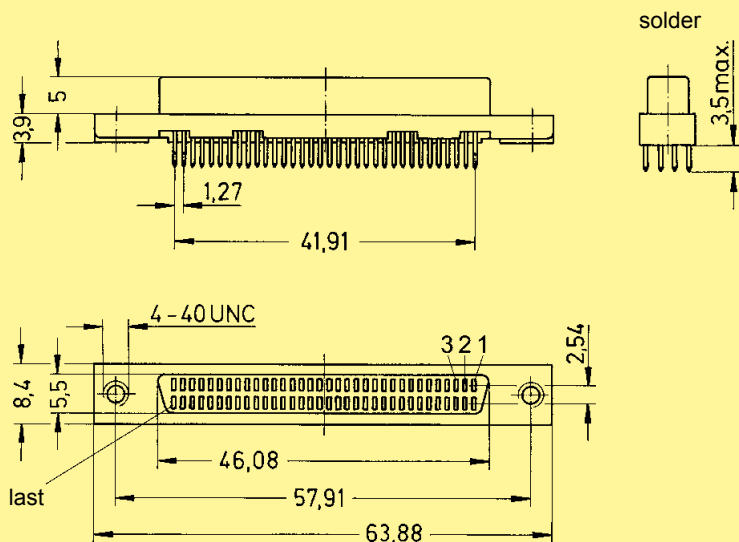

Board drillings
(Components side)

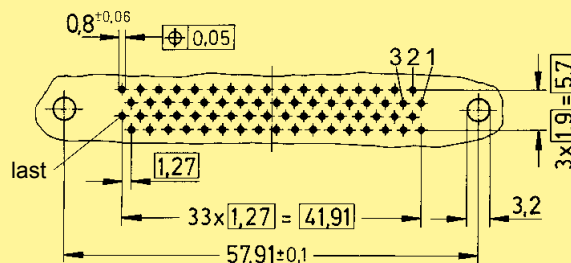

Dimensions in mm

SMC technology

Number of contacts

68

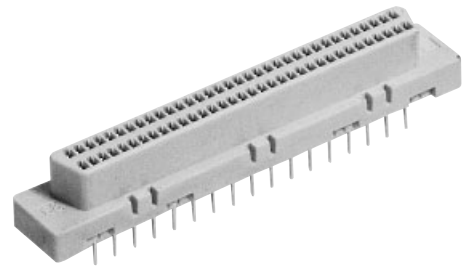

SMC female connectors, straight

Identification	No. of contacts	Part No.
SMC female connector with straight solder pins	68	60 05 068 5100

Dimensions

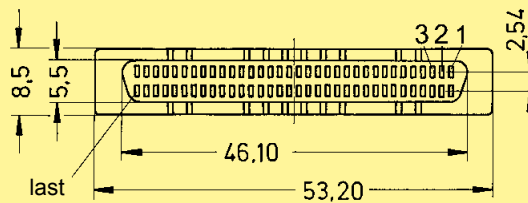
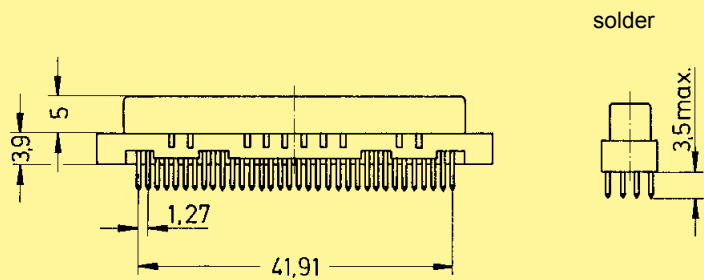

Board drillings
(Components side)

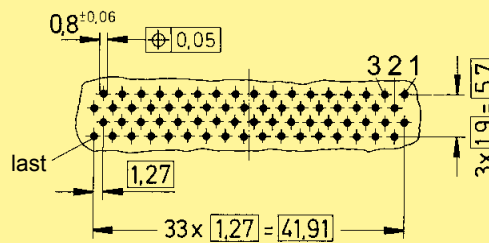

Number of contacts	14, 20, 26, 36, 50, 68
Pitch	1.27 mm
Working current	1 A
Working voltage	240 V ~
Test voltage $U_{r.m.s.}$	500 V
Contact resistance	$\leq 45 \text{ m}\Omega$
Insulation resistance	$\geq 10^3 \text{ M}\Omega$
Temperature range reflow soldering	-55 °C ... + 105 °C according to ICP/JEDEC J-STD-020 Revision D
Terminations	
Solder pins	Angled for pcb holes min. $\varnothing 0.62 \text{ mm}$
Materials	
Moulding	Thermoplastic resin glass-fibre filled UL 94-V0 Liquid Crystal Polymer (LCP)
Contacts	Copper alloy
Contact surface	
Contact zone	Selectively gold plated according to performance level
Metal shell	Die cast zamac or stamped steel, nickel-plated

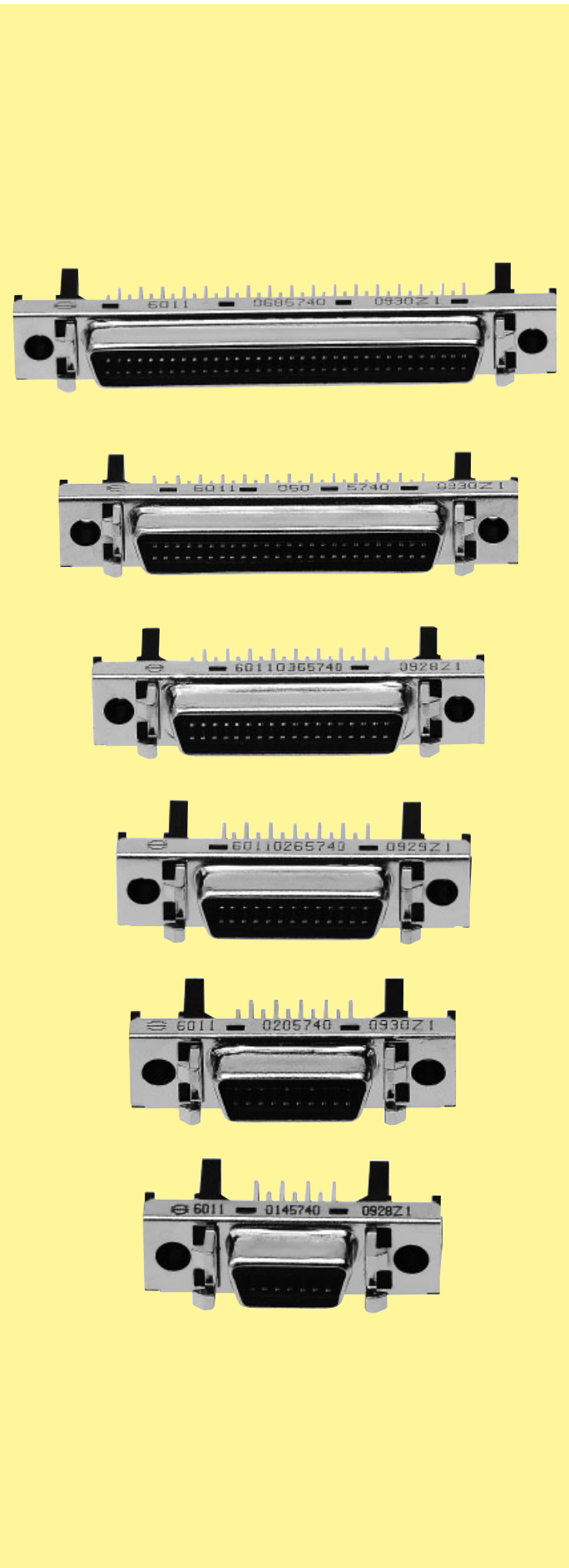

SMC
technology

Number of contacts

14-68

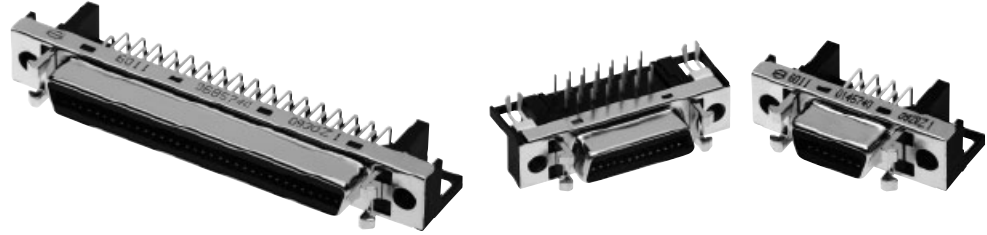

SMC female connectors, angled

Identification	No. of contacts	for one reel (300 pieces)		Part No.	standard tray packaging
SMC female connectors with angled solder pins	14	60 11 014 57	.. 710	60 11 014 57	..
	20	60 11 020 57	.. 710	60 11 020 57	..
	26	60 11 026 57	.. 710	60 11 026 57	..
	36	60 11 036 57	.. 710	60 11 036 57	..
	50	60 11 050 57	.. 710	60 11 050 57	..
	68	60 11 068 57	.. 710	60 11 068 57	..
	Without board lock	32			
With board lock	40				

Dimensions

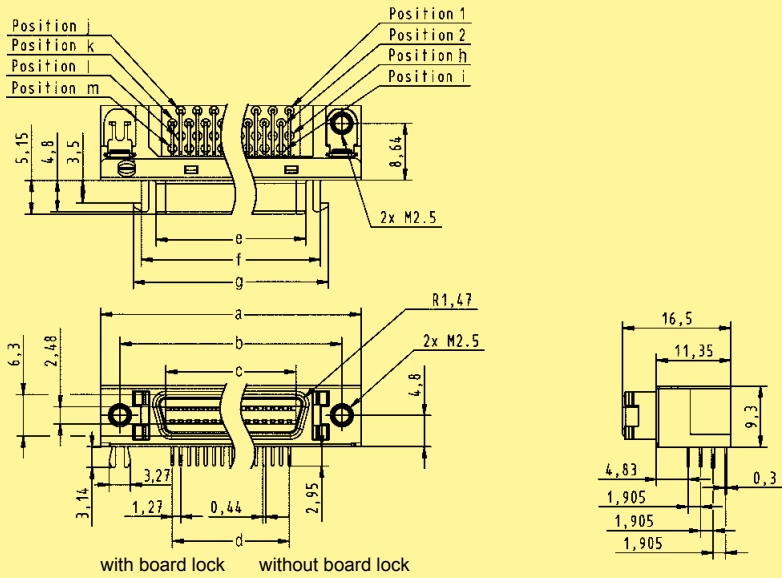

	a	b	c	d	e	f	g	h	i	j	k	l	m	n
14	29.54	23.64	9.62	7.62	12.62	17.14	19.54	8	9	7	6	14	13	44.0
20	33.35	27.45	13.43	11.43	16.43	20.95	23.35	11	12	9	10	19	20	56.5
26	37.16	31.26	17.24	15.24	20.24	24.76	27.16	14	15	13	12	26	25	56.0
36	43.51	37.61	23.59	21.59	26.59	31.11	33.51	19	20	17	18	35	36	56.0
50	52.40	46.50	32.48	30.48	35.48	40.00	42.40	26	27	25	24	50	49	72.5
68	63.83	57.93	43.91	41.91	46.91	51.43	53.83	35	36	33	34	67	68	88.5

Board drillings (Components side)

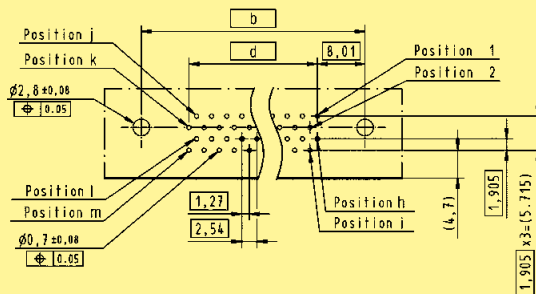

Packaging

(1 reel = 300 pieces)
Reel diameter = 380 mm

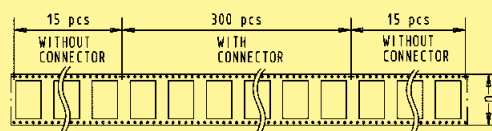

Dimensions in mm

Number of contacts

68



SMC female connectors, angled

Identification	No. of contacts	Part No.
SMC female connectors with angled solder pins and pick & place pad	68	60 11 068 5739
	68	60 11 068 5749

Dimensions

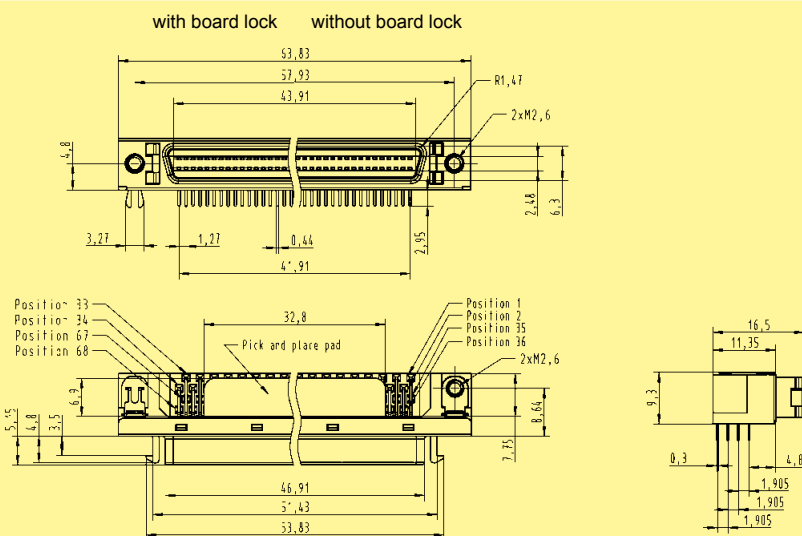

Board drillings (Components side)

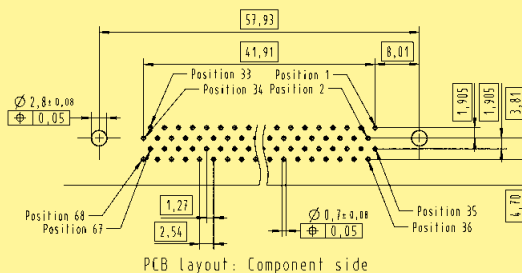

Packaging (1 tray = 18 pieces)

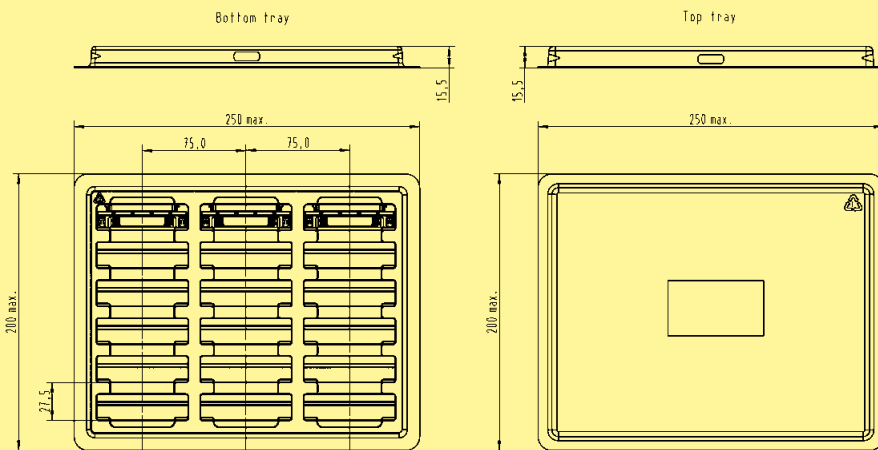

Dimensions in mm

SMC technology

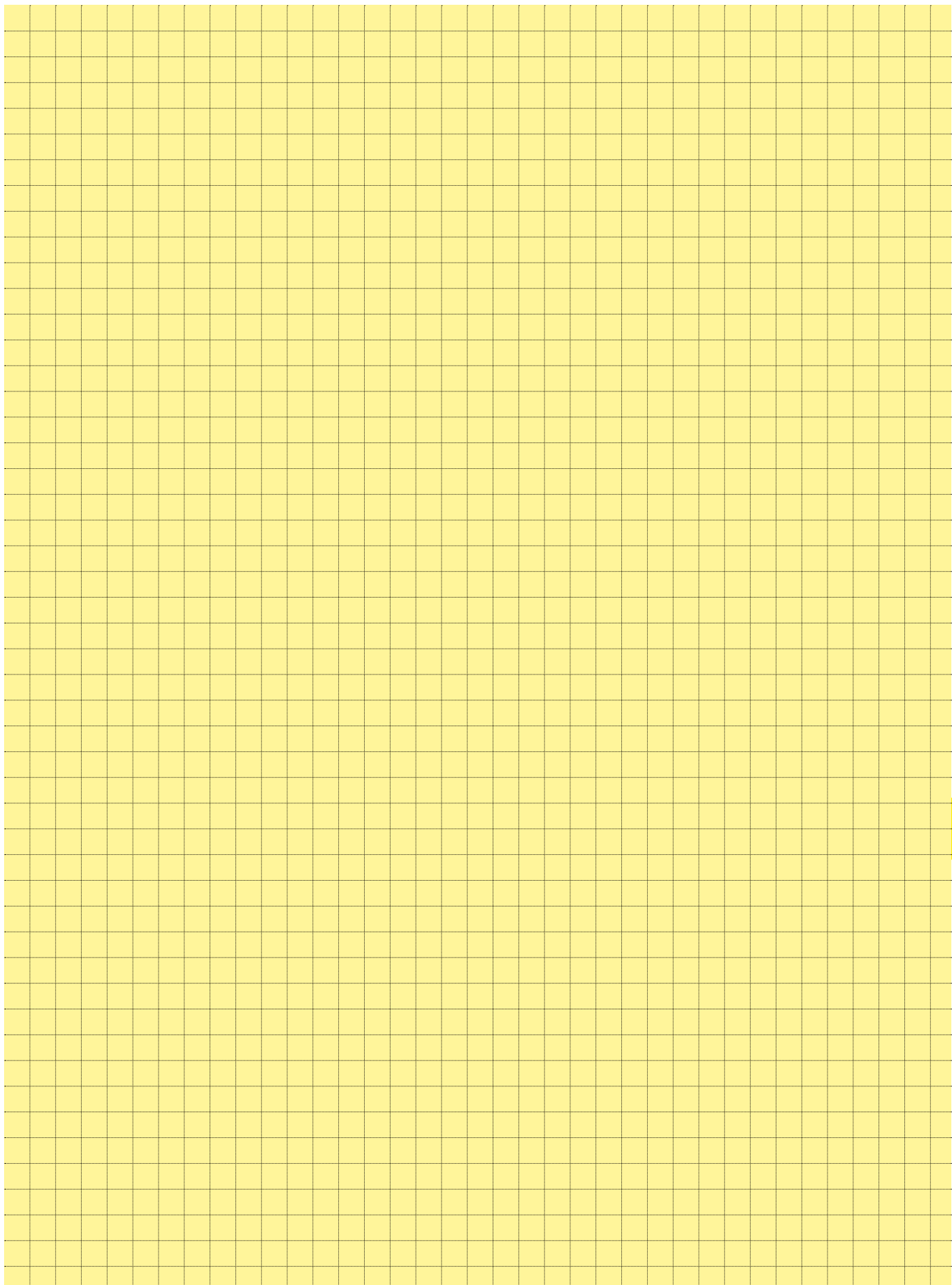

Number of contacts 9, 15, 25, 37
UL recognized

Working current
see current carrying capacity chart
Stamped contacts 6.5 A max.

Test voltage $U_{r.m.s.}$ 1 kV

Clearance and creepage ≥ 1.0 mm

Contact resistance ≤ 10 m Ω
Insulation resistance $\geq 10^{10}$ Ω

Temperature range -55 °C ... + 125 °C
during reflow soldering max. + 240 °C for 15 s
The higher temperature limit includes the local ambient and heating effect of the contacts under load. All connectors are suitable for standard reflow processes.

Terminations
a) Solder pins \varnothing 0.6 mm for P.C.B. holes \varnothing 0.8/1 mm
b) Solder pins, angled 90° \varnothing 0.6 mm for P.C.B. holes \varnothing 1 mm

Materials
Mouldings Thermoplastic resin, glass-fibre filled (PCT), UL 94-V0

Contacts Copper alloy

Contact surface
Contact zone selectively plated according to performance level¹⁾

Metal shell Plated steel

Insertion and withdrawal force
Connector on P.C.B.
Solder, straight with clips
– insertion max. per connector: 60 N
– withdrawal min. per connector: 10 N

Mating force
9 way ≤ 30 N
15 way ≤ 50 N
25 way ≤ 83 N
37 way ≤ 123 N

Current carrying capacity

The current carrying capacity is limited by maximum temperature of materials for inserts and contacts including terminals.

The current capacity-curve is valid for continuous, not interrupted current-loaded contacts of connectors when simultaneous power on all contacts is given, without exceeding the maximum temperature.

Control and test procedures according to DIN IEC 60 512.

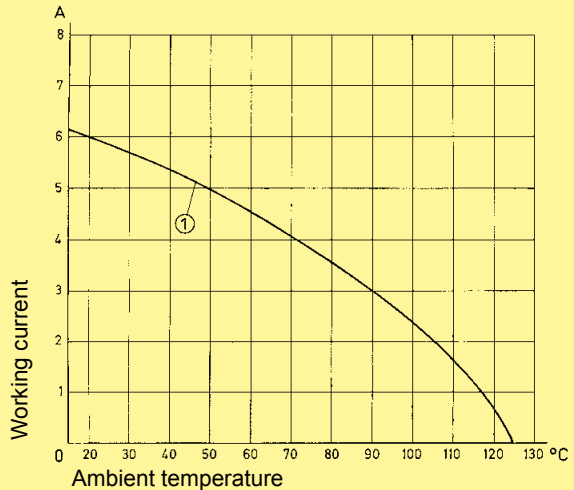

Example: 25 way connector

① Stamped contacts

Contact arrangement View from termination side

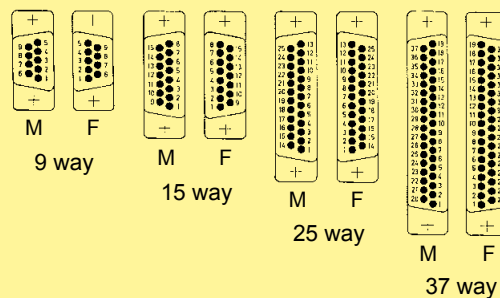

M = Male connector
F = Female connector

Mating conditions as per DIN 41 652

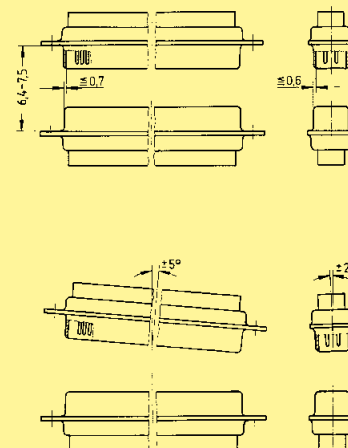

SMC technology

¹⁾ Performance level 3, 50 mating cycles, no gas test
Performance level 2 as per CECC 75 301-802, 250 mating cycles, 4 days 4 mixed gas test – IEC 60 512
Performance level 1 as per CECC 75 301-802, 500 mating cycles, 10 days 4 mixed gas test – IEC 60 512

Identification

Drawing

Dimensions in mm

Standard Versions

Mounting height 7.3 mm
 9-37 way
 for front panel
 4 units of width (TE)

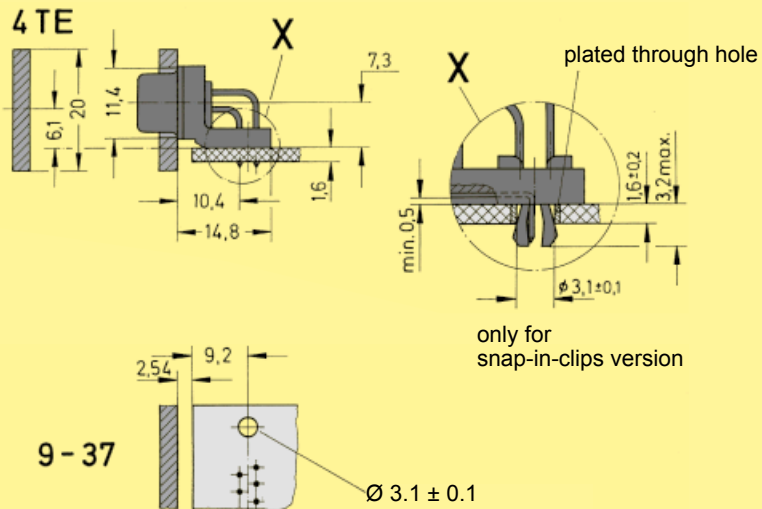

for connectors see pages 22.14 – 22.15

Low-Profile Versions

Mounting height 3.6 mm
 9-37 way
 for front panel
 3 units of width (TE)

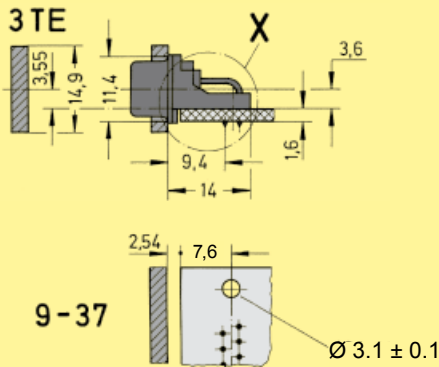

for connectors see pages 22.16 – 22.17

Panel cut out for front/rear mount

Values are taken from the CECC 75 301-802

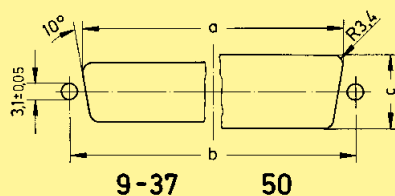

	Front mount			Rear mount			
	a±0.2	b±0.13	c±0.2	a±0.2	b±0.13	c±0.2	
9	22.2	25.0	12.3	9	20.5	25.0	11.4
15	30.5	33.3	12.3	15	28.8	33.3	11.4
25	44.3	47.0	12.3	25	42.5	47.0	11.4
37	60.7	63.5	12.3	37	59.1	63.5	11.4
50	58.3	61.1	15.1	50	56.3	61.1	14.1

Number of contacts

9-37

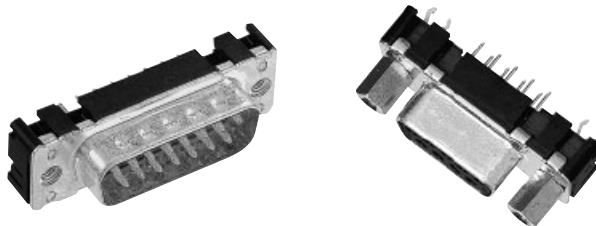

SMC stamped solder pins, straight with/without grounding board locks

Identification	No. of contacts	Part No.	
Performance levels Explanations see page 22.10 Other performance levels on request		Performance level 3	Performance level 2
Male connector metal shell with dimples			
Without grounding board locks	9 15 25 37	09 65 129 770 09 65 229 770 09 65 329 770 09 65 429 770	09 65 129 670 09 65 229 670 09 65 329 670 09 65 429 670
With grounding board locks	9 15 25 37	09 65 169 771 09 65 269 771 09 65 369 771 09 65 469 771	09 65 169 671 09 65 269 671 09 65 369 671 09 65 469 671
Female connector metal shell			
Without grounding board locks	9 15 25 37	09 66 115 750 09 66 215 750 09 66 315 750 09 66 415 750	09 66 115 650 09 66 215 650 09 66 315 650 09 66 415 650
With grounding board locks	9 15 25 37	09 66 155 751 09 66 255 751 09 66 355 751 09 66 455 751	09 66 155 651 09 66 255 651 09 66 355 651 09 66 455 651
Please insert digit for flange thread or fitted female screw locks			
M3 ▶ 1 4-40 UNC ▶ 2 fitted screw locks 4-40 UNC ▶ 3 ¹⁾			

SMC technology

¹⁾ Fitted screw locks 4-40 UNC not normally kept in stock for performance level 3
 Connector dimensions see page 22.13. Mating conditions see page 22.10.

Number of contacts

9-37

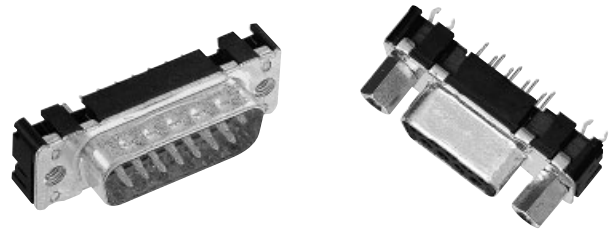

SMC stamped solder pins, straight with/without grounding board locks

Identification

Drawing

Dimensions in mm

Male connector

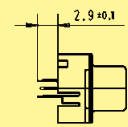
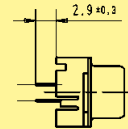
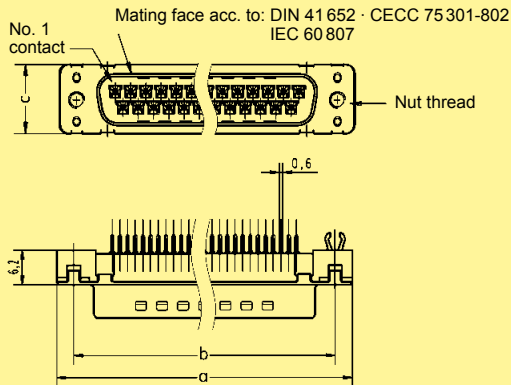

Female connector

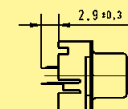
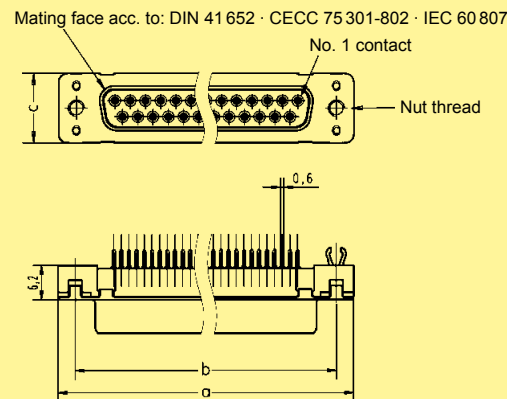

	a	b _{±0.1}	c	g		h	
9	30.9	25.0	12.5	4 x	2.74 = 10.96	3 x	2.74 = 8.22
15	39.2	33.3	12.5	7 x	2.74 = 19.18	6 x	2.74 = 16.44
25	53.1	47.0	12.5	12 x	2.76 = 33.12	11 x	2.76 = 30.36
37	69.4	63.5	12.5	18 x	2.76 = 49.68	17 x	2.76 = 46.92

Board drillings

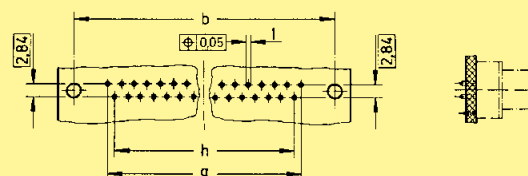

Standard Versions

Number of contacts

Mounting height

9-37

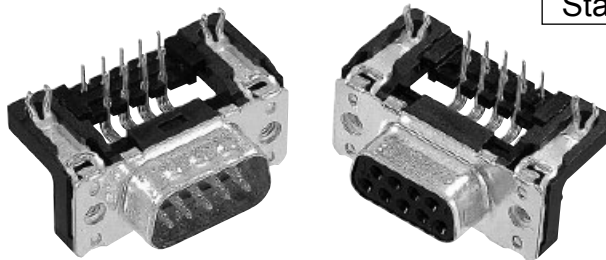
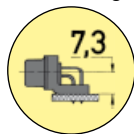

SMC stamped solder pins, angled with grounding board locks

Identification	No. of contacts	Part No.	
Performance levels Explanations see page 22.10 Other performance levels on request		Performance level 3	
		Performance level 2	
Male connector metal shell with dimples		2.84 mm pitch	
	9	09 65 167 781 . 1)	09 65 167 681 . 1)
	15	09 65 267 781 . 1)	09 65 267 681 . 1)
	25	09 65 367 781 . 1)	09 65 367 681 . 1)
	37	09 65 467 781 . 1)	09 65 467 681 . 1)
		2.54 mm pitch	
	9	09 65 166 781 .	09 65 166 681 .
	15	09 65 266 781 .	09 65 266 681 .
	25	09 65 366 781 .	09 65 366 681 .
	37	09 65 466 781 .	09 65 466 681 .
Female connector metal shell		2.84 mm pitch	
	9	09 66 157 761 . 1)	09 66 157 661 . 1)
	15	09 66 257 761 . 1)	09 66 257 661 . 1)
	25	09 66 357 761 . 1)	09 66 357 661 . 1)
	37	09 66 457 761 . 1)	09 66 457 661 . 1)
		2.54 mm pitch	
	9	09 66 156 761 .	09 66 156 661 .
	15	09 66 256 761 .	09 66 256 661 .
	25	09 66 356 761 .	09 66 356 661 .
	37	09 66 456 761 .	09 66 456 661 .
Please insert digit for flange thread or fitted female screw locks			
Ø 3.1 mm hole ▶ 0 ¹⁾			
M3 ▶ 1			
4-40 UNC ▶ 2			
fitted screw locks 4-40 UNC ▶ 3			

SMC technology

¹⁾ Not normally kept in stock

Standard Versions

Number of contacts

9-37

Mounting height

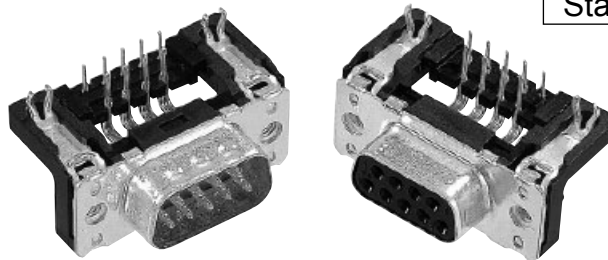
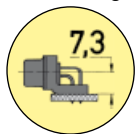

SMC stamped solder pins, angled with grounding board locks

Identification

Drawing

Dimensions in mm

Male connector

Mating face acc. to: DIN 41 652 · CECC 75 301-802
IEC 60 807

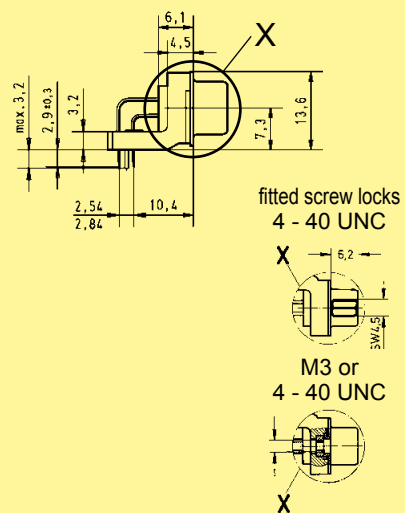
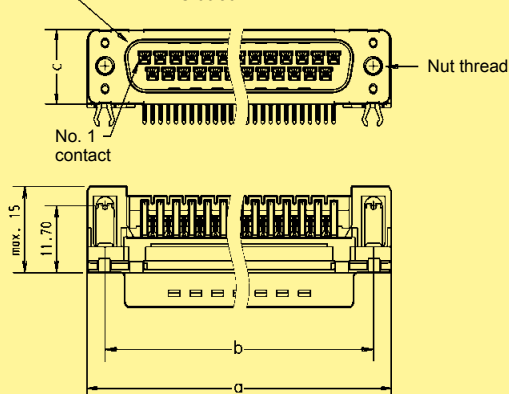

Female connector

Mating face acc. to: DIN 41 652 · CECC 75 301-802
IEC 60 807

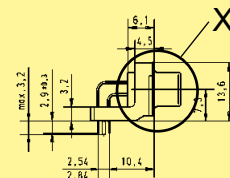
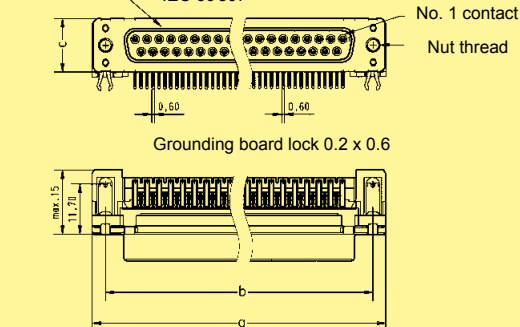

Board drillings

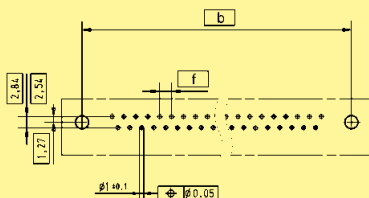

	a	b±0.1	c	f
9	30.90	25.00	12.50	2.74
15	39.20	33.30	12.50	2.74
25	53.10	47.00	12.50	2.76
37	69.40	63.50	12.50	2.76

Low-Profile Versions

Number of contacts

Mounting height

9-37

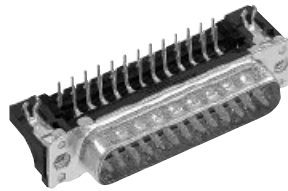
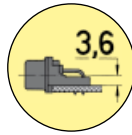

SMC stamped solder pins, angled with grounding board locks

Identification	No. of contacts	Part No.	
Performance levels Explanations see page 22.10 Other contact surfaces on request		Performance level 3	Performance level 2
Male connector metal shell with dimples	9 15 25 37	09 65 166 781 . 09 65 266 781 . 09 65 366 781 . 09 65 466 781 .	09 65 166 681 . 09 65 266 681 . 09 65 366 681 . 09 65 466 681 .
Female connector metal shell	9 15 25 37	09 66 156 761 . 09 66 256 761 . 09 66 356 761 . 09 66 456 761 .	09 66 156 661 . 09 66 256 661 . 09 66 356 661 . 09 66 456 661 .
Please insert digit for flange thread or fitted female screw locks			
M3 ▶ 5 4-40 UNC ▶ 6 fitted screw locks 4-40 UNC ▶ 7			

SMC technology

Low-Profile Versions

Number of contacts

9-37

Mounting height

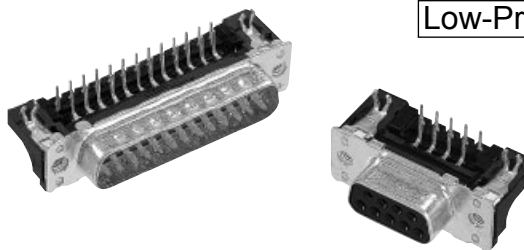
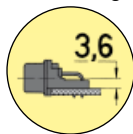

SMC stamped solder pins, angled with grounding board locks

Identification

Drawing

Dimensions in mm

Male connector

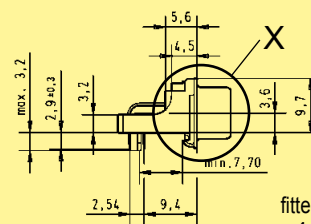
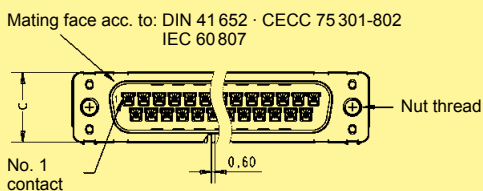

fitted screw locks
4 - 40 UNC

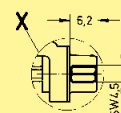

M3 or
4 - 40 UNC

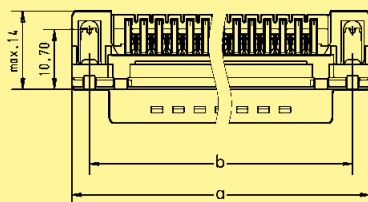
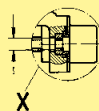

Female connector

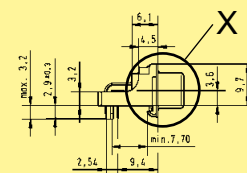
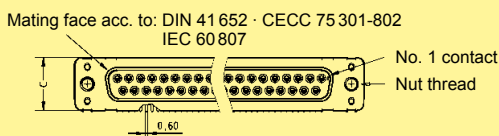

Grounding board lock 0.2 x 0.6

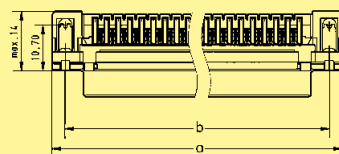

Board drillings

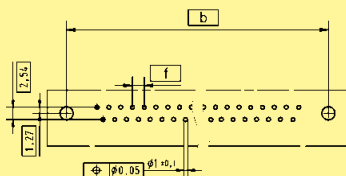

	a	b±0.1	c	f
9	30.90	25.00	12.50	2.74
15	39.20	33.30	12.50	2.74
25	53.10	47.00	12.50	2.76
37	69.40	63.50	12.50	2.76

Number of contacts 6, 10, 14, 16, 20, 24, 26, 30, 34, 40, 50, 60, 64

Contact arrangement straight, angled

Contact length 2.9 mm

Approvals IEC 60 603-13
DIN EN 60 603-13
D 2632
BT 224
NFC 93-428 (HE 10)

Pitch 2.54 mm [0.100"]

Working current 1 A

Working voltage 500 V
for pollution degree 1

Test voltage $U_{r.m.s.}$ 1 kV

Contact resistance $\leq 20 \text{ m}\Omega$
Insulation resistance $\geq 10^9 \Omega$

Temperature range -55 °C ... + 125 °C
during reflow soldering max. + 240 °C for 60 s
The higher temperature limit includes the local ambient and heating effect of the contacts under load

Terminations For pcb hole $\varnothing 1 \pm 0.1 \text{ mm}$
DIN IEC 52 141
Diagonal: 0.79 mm

Materials Moulding Thermoplastic resin (PCT)
UL 94-V0

Contact surface Contact zone gold-plated according to performance level¹⁾

Options on request

Colour of connectors black

For pick & place process Tape & Reel packaging with/without vacuum plate
Tube packaging with/without vacuum plate



New

Insertion and withdrawal forces

Number of contacts	Maximum force [N]	
	Performance level 1 and 2	Performance level 3
6	12	18
10	20	30
14	28	42
16	32	48
20	40	60
24	48	72
26	52	78
30	60	90
34	68	102
40	80	120
50	100	150
60	120	180
64	128	192



¹⁾ Performance level 3 as per IEC 60 603-13, ≥ 50 mating cycles, no gas test
Performance level 2 as per IEC 60 603-13, ≥ 250 mating cycles, 4 days gas test
S4, plating = 0.76 μm (30 μinch) Au or PdNi equivalent

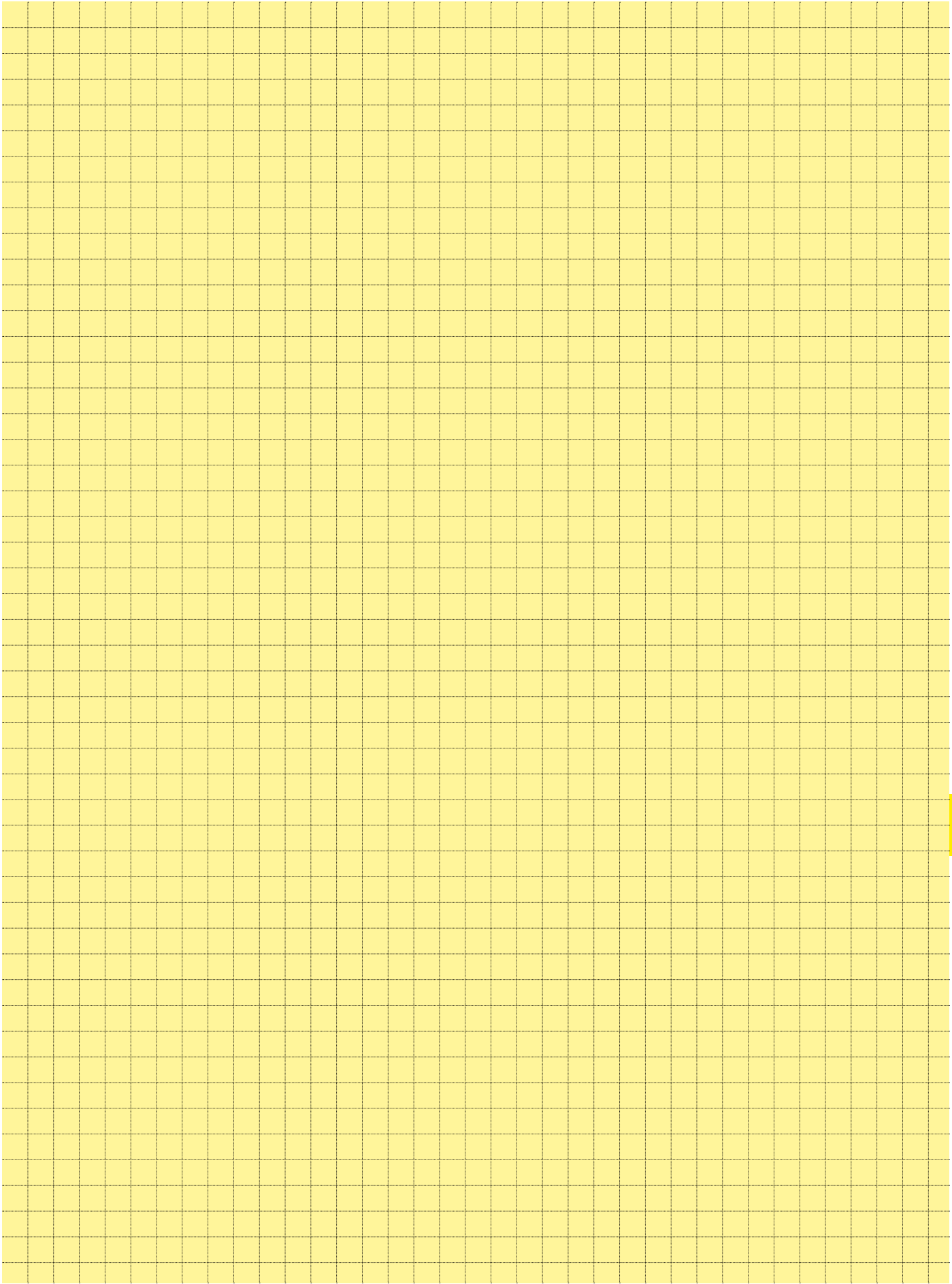

Number of contacts

6-64



SMC male header with angled solder pins

Identification	No. of contacts	Part No.					
		Without levers		With short levers		With long levers	
SMC male header with angled solder pins Length: 2.9 mm	6	09 19 506	└ 923	09 19 506	└ 913	09 19 506	└ 903
	10	09 19 510	└ 923	09 19 510	└ 913	09 19 510	└ 903
	14	09 19 514	└ 923	09 19 514	└ 913	09 19 514	└ 903
	16	09 19 516	└ 923	09 19 516	└ 913	09 19 516	└ 903
	20	09 19 520	└ 923	09 19 520	└ 913	09 19 520	└ 903
	24	09 19 524	└ 923	09 19 524	└ 913	09 19 524	└ 903
	26	09 19 526	└ 923	09 19 526	└ 913	09 19 526	└ 903
	30	09 19 530	└ 923	09 19 530	└ 913	09 19 530	└ 903
	34	09 19 534	└ 923	09 19 534	└ 913	09 19 534	└ 903
	40	09 19 540	└ 923	09 19 540	└ 913	09 19 540	└ 903
	50	09 19 550	└ 923	09 19 550	└ 913	09 19 550	└ 903
	60	09 19 560	└ 923	09 19 560	└ 913	09 19 560	└ 903
	64	09 19 564	└ 923	09 19 564	└ 913	09 19 564	└ 903

SMC technology

22
22

Kinked version on request

* Not normally kept in stock
For accessories see page 22.30
For dimensions see page 22.21

For performance level 3 please specify digit 7*
For performance level 2 please specify digit 6*
S4 = 0.76 µm (30 µinch) Au or PdNi equivalent

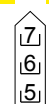

Number of contacts

6-64



SMC male header with angled solder pins

Identification

Drawing

Dimensions in mm

SMC male header

No. of contacts	A	B	D	E	F	G
6	26.9	16.76	12.45	2.54 x 2 = 5.08	36.9	40.3
10	32.0	21.84	17.53	2.54 x 4 = 10.16	42.0	45.4
14	37.1	26.92	22.61	2.54 x 6 = 15.24	47.1	50.4
16	39.6	29.46	25.15	2.54 x 7 = 17.78	49.6	53.0
20	44.7	34.54	30.23	2.54 x 9 = 22.86	54.7	58.1
24	49.8	39.62	35.91	2.54 x 11 = 27.94	59.8	63.2
26	52.3	42.16	37.85	2.54 x 12 = 30.48	62.3	65.7
30	57.7	47.24	43.83	2.54 x 14 = 35.56	68.2	68.6
34	62.5	52.32	48.01	2.54 x 16 = 40.64	72.5	75.8
40	70.1	59.94	55.63	2.54 x 19 = 48.26	80.1	83.5
50	82.8	72.64	68.33	2.54 x 24 = 60.96	92.8	96.2
60	95.5	85.34	81.03	2.54 x 29 = 73.66	105.5	108.9
64	100.6	90.42	86.11	2.54 x 31 = 78.74	110.6	113.9

Short levers

for use with female connector without strain relief clamp

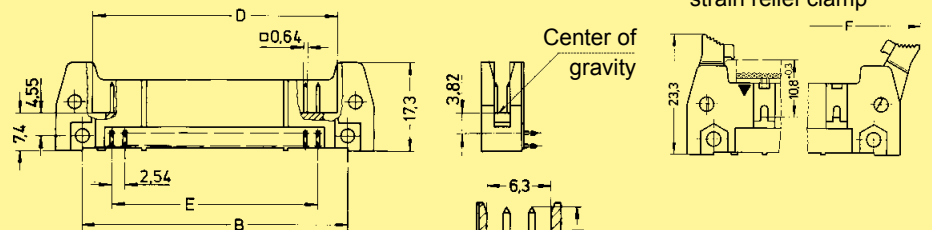

Long levers

for use with female connector with strain relief clamp

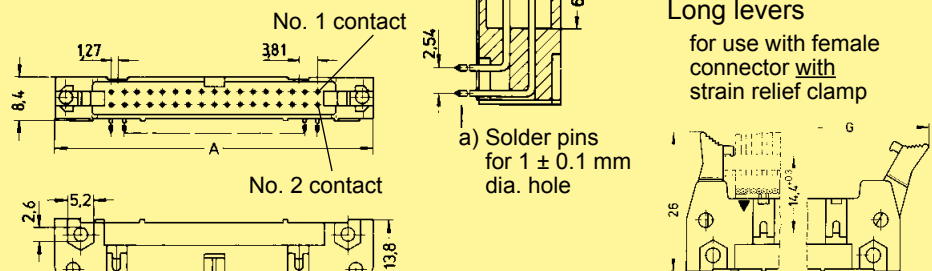

No. 1 contact

No. 2 contact

Marking No. 1 contact

No. 1 contact

No. 2 contact

Board drillings

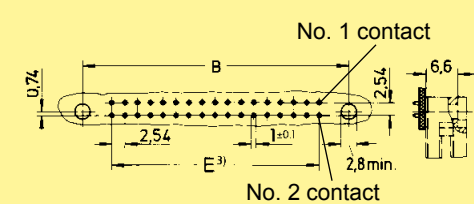

1) No polarization slot for 6, 10 or 14 way male header

2) No polarization slot for 6 way male header

3) Pitch tolerance: ± 0.1

Number of contacts

6-64

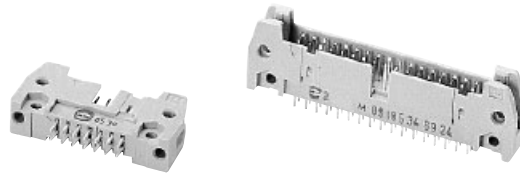

SMC male header with straight solder pins

Identification	No. of contacts	Part No.					
		Without levers		With short levers		With long levers	
SMC male header with straight solder pins Length: 2.9 mm	6	09 19 506	└ 924	09 19 506	└ 914	09 19 506	└ 904
	10	09 19 510	└ 924	09 19 510	└ 914	09 19 510	└ 904
	14	09 19 514	└ 924	09 19 514	└ 914	09 19 514	└ 904
	16	09 19 516	└ 924	09 19 516	└ 914	09 19 516	└ 904
	20	09 19 520	└ 924	09 19 520	└ 914	09 19 520	└ 904
	24	09 19 524	└ 924	09 19 524	└ 914	09 19 524	└ 904
	26	09 19 526	└ 924	09 19 526	└ 914	09 19 526	└ 904
	30	09 19 530	└ 924	09 19 530	└ 914	09 19 530	└ 904
	34	09 19 534	└ 924	09 19 534	└ 914	09 19 534	└ 904
	40	09 19 540	└ 924	09 19 540	└ 914	09 19 540	└ 904
	50	09 19 550	└ 924	09 19 550	└ 914	09 19 550	└ 904
	60	09 19 560	└ 924	09 19 560	└ 914	09 19 560	└ 904
	64	09 19 564	└ 924	09 19 564	└ 914	09 19 564	└ 904

SMC technology

* Not normally kept in stock
 For accessories see page 22.30
 For dimensions see page 22.23

For performance level 3 please specify digit 7*
 For performance level 2 please specify digit 6*
 S4 = 0.76 µm (30 µinch) Au or PdNi equivalent



Number of contacts

6-64

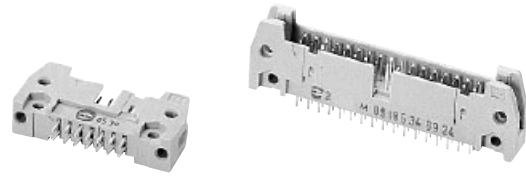

SMC male header with straight solder pins

Identification

Drawing

Dimensions in mm

SMC male header

No. of contacts	A	C	D	E	F	G
6	26.9	22.86	12.45	2.54 x 2 = 5.08	36.9	40.3
10	32.0	27.94	17.53	2.54 x 4 = 10.16	42.0	45.4
14	37.1	33.02	22.61	2.54 x 6 = 15.24	47.1	50.4
16	39.6	35.56	25.15	2.54 x 7 = 17.78	49.6	53.0
20	44.7	40.64	30.23	2.54 x 9 = 22.86	54.7	58.1
24	49.8	45.72	35.91	2.54 x 11 = 27.94	59.8	63.2
26	52.3	48.26	37.85	2.54 x 12 = 30.48	62.3	65.7
30	57.7	53.34	43.83	2.54 x 14 = 35.56	68.2	68.6
34	62.5	58.42	48.01	2.54 x 16 = 40.64	72.5	75.8
40	70.1	66.04	55.63	2.54 x 19 = 48.26	80.1	83.5
50	82.8	78.74	68.33	2.54 x 24 = 60.96	92.8	96.2
60	95.5	91.44	81.03	2.54 x 29 = 73.66	105.5	108.9
64	100.6	96.52	86.11	2.54 x 31 = 78.74	110.6	113.9

Short levers

for use with female connector without strain relief clamp

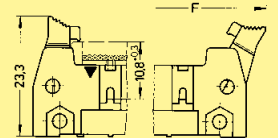
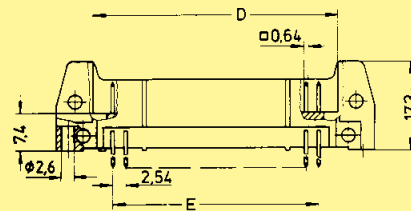

Long levers

for use with female connector with strain relief clamp

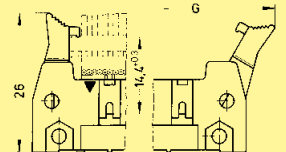
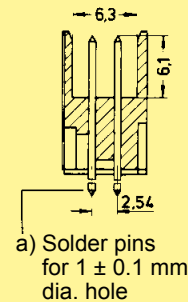
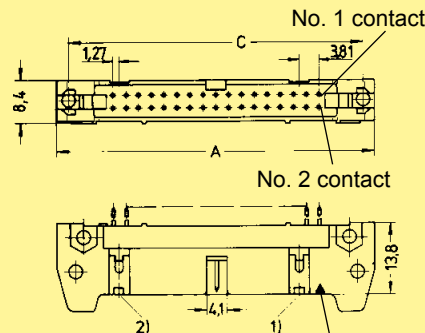

Marking No. 1 contact

Board drillings

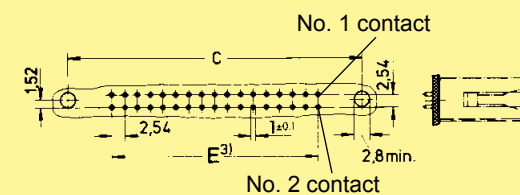

1) No polarization slot for 6, 10 or 14 way male header

2) No polarization slot for 6 way male header

3) Pitch tolerance: ± 0.1

Number of contacts

6-64

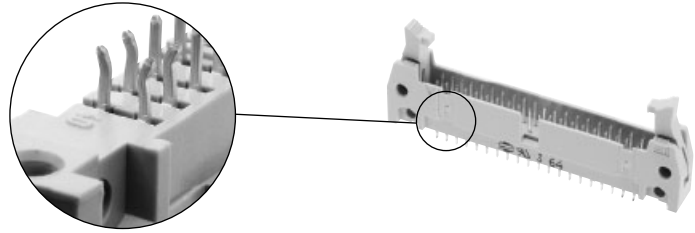

SMC male header with straight solder pins, kinked

Identification	No. of contacts	Part No.					
		Without levers		With short levers		With long levers	
SMC male header with straight solder pins, kinked Length: 2.9 mm	6	09 19 506	└ 024	09 19 506	└ 014	09 19 506	└ 004
	10	09 19 510	└ 024	09 19 510	└ 014	09 19 510	└ 004
	14	09 19 514	└ 024	09 19 514	└ 014	09 19 514	└ 004
	16	09 19 516	└ 024	09 19 516	└ 014	09 19 516	└ 004
	20	09 19 520	└ 024	09 19 520	└ 014	09 19 520	└ 004
	24	09 19 524	└ 024	09 19 524	└ 014	09 19 524	└ 004
	26	09 19 526	└ 024	09 19 526	└ 014	09 19 526	└ 004
	30	09 19 530	└ 024	09 19 530	└ 014	09 19 530	└ 004
	34	09 19 534	└ 024	09 19 534	└ 014	09 19 534	└ 004
	40	09 19 540	└ 024	09 19 540	└ 014	09 19 540	└ 004
	50	09 19 550	└ 024	09 19 550	└ 014	09 19 550	└ 004
	60	09 19 560	└ 024	09 19 560	└ 014	09 19 560	└ 004
	64	09 19 564	└ 024	09 19 564	└ 014	09 19 564	└ 004

SMC technology

* Not normally kept in stock
For accessories see page 22.30
For dimensions see page 22.25

For performance level 3 please specify digit 7*
For performance level 2 please specify digit 6*
S4 = 0.76 µm (30 µinch) Au or PdNi equivalent

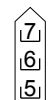

Number of contacts

6-64

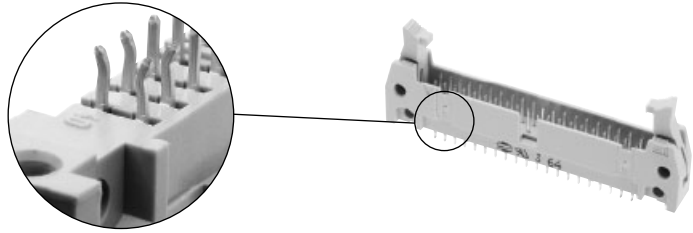

SMC male header with straight solder pins, kinked

Identification

Drawing

Dimensions in mm

SMC male header

No. of contacts	A	C	D	E	F	G
6	26.9	22.86	12.45	2.54 x 2 = 5.08	36.9	40.3
10	32.0	27.94	17.53	2.54 x 4 = 10.16	42.0	45.4
14	37.1	33.02	22.61	2.54 x 6 = 15.24	47.1	50.4
16	39.6	35.56	25.15	2.54 x 7 = 17.78	49.6	53.0
20	44.7	40.64	30.23	2.54 x 9 = 22.86	54.7	58.1
24	49.8	45.72	35.91	2.54 x 11 = 27.94	59.8	63.2
26	52.3	48.26	37.85	2.54 x 12 = 30.48	62.3	65.7
30	57.7	53.34	43.83	2.54 x 14 = 35.56	68.2	68.6
34	62.5	58.42	48.01	2.54 x 16 = 40.64	72.5	75.8
40	70.1	66.04	55.63	2.54 x 19 = 48.26	80.1	83.5
50	82.8	78.74	68.33	2.54 x 24 = 60.96	92.8	96.2
60	95.5	91.44	81.03	2.54 x 29 = 73.66	105.5	108.9
64	100.6	96.52	86.11	2.54 x 31 = 78.74	110.6	113.9

Short levers

for use with female connector without strain relief clamp

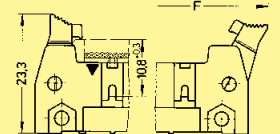
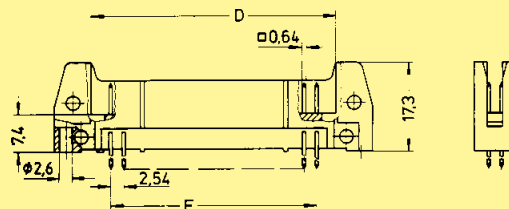

Long levers

for use with female connector with strain relief clamp

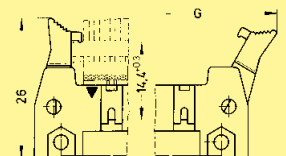
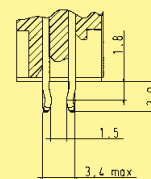
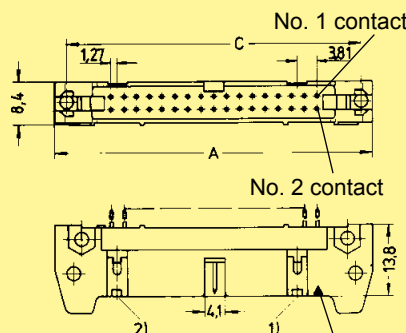

Board drillings

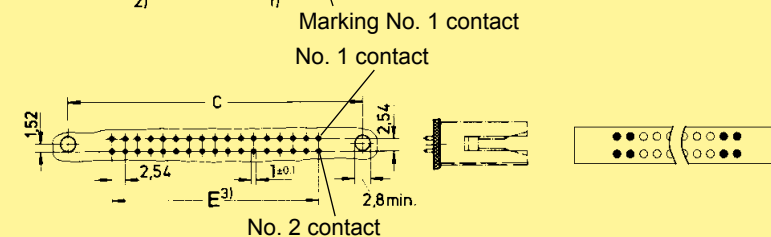

- Kinked contact: pcb thickness from 1.50 to 1.94 mm after Cu + Sn plating with non-remelted through holes \varnothing 0.80 to \varnothing 0.95 mm. Max. insertion force = 125 N. Min. retention force = 6 N.
- Non-kinked contact: Solder pins for pcb connections \varnothing 1 ± 0.1 mm as per IEC 60603-13.

1) No polarization slot for 6, 10 or 14 way male header

2) No polarization slot for 6 way male header

3) Pitch tolerance: ± 0.1

Number of contacts

6-64

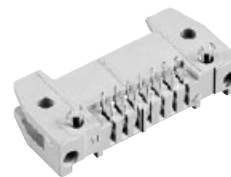

SMC male header with angled solder pins and board lock

Identification	No. of contacts	Part No.					
		Without levers		With short levers		With long levers	
SMC male header with angled solder pins and pcb board lock Length: 2.9 mm for 1.6 mm pcb thickness To hold the connector on the pcb before the soldering process, two board locks have been added on the male header with angled solder pins.	6	09 19 506	└ 973*	09 19 506	└ 963*	09 19 506	└ 953*
	10	09 19 510	└ 973*	09 19 510	└ 963*	09 19 510	└ 953*
	14	09 19 514	└ 973*	09 19 514	└ 963*	09 19 514	└ 953*
	16	09 19 516	└ 973*	09 19 516	└ 963*	09 19 516	└ 953*
	20	09 19 520	└ 973*	09 19 520	└ 963*	09 19 520	└ 953*
	24	09 19 524	└ 973*	09 19 524	└ 963*	09 19 524	└ 953*
	26	09 19 526	└ 973*	09 19 526	└ 963*	09 19 526	└ 953*
	30	09 19 530	└ 973*	09 19 530	└ 963*	09 19 530	└ 953*
	34	09 19 534	└ 973*	09 19 534	└ 963*	09 19 534	└ 953*
	40	09 19 540	└ 973*	09 19 540	└ 963*	09 19 540	└ 953*
	50	09 19 550	└ 973*	09 19 550	└ 963*	09 19 550	└ 953*
	60	09 19 560	└ 973*	09 19 560	└ 963*	09 19 560	└ 953*
	64	09 19 564	└ 973*	09 19 564	└ 963*	09 19 564	└ 953*

SMC technology

22-28

* Not normally kept in stock

For performance level 3 please specify digit 7
 For performance level 2 please specify digit 6
 S4 = 0.76 µm (30 µinch) Au or PdNi equivalent

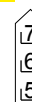
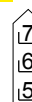
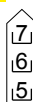

Number of contacts

6-64

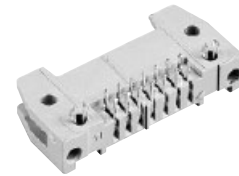

SMC male header with angled solder pins and board lock

Identification

Drawing

Dimensions in mm

SMC male header

No. of contacts	A	B	D	E	F	G
6	26.9	16.76	12.45	2.54 x 2 = 5.08	36.9	40.3
10	32.0	21.84	17.53	2.54 x 4 = 10.16	42.0	45.4
14	37.1	26.92	22.61	2.54 x 6 = 15.24	47.1	50.4
16	39.6	29.46	25.15	2.54 x 7 = 17.78	49.6	53.0
20	44.7	34.54	30.23	2.54 x 9 = 22.86	54.7	58.1
24	49.8	39.62	35.91	2.54 x 11 = 27.94	59.8	63.2
26	52.3	42.16	37.85	2.54 x 12 = 30.48	62.3	65.7
30	57.7	47.24	43.83	2.54 x 14 = 35.56	68.2	68.6
34	62.5	52.32	48.01	2.54 x 16 = 40.64	72.5	75.8
40	70.1	59.94	55.63	2.54 x 19 = 48.26	80.1	83.5
50	82.8	72.64	68.33	2.54 x 24 = 60.96	92.8	96.2
60	95.5	85.34	81.03	2.54 x 29 = 73.66	105.5	108.9
64	100.6	90.42	86.11	2.54 x 31 = 78.74	110.6	113.9

Short levers

for use with female connector without strain relief clamp

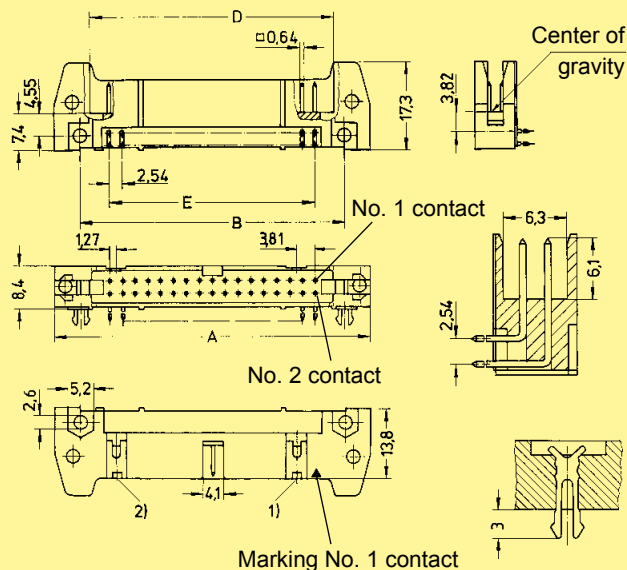

Long levers

for use with female connector with strain relief clamp

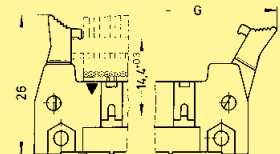

Board drillings

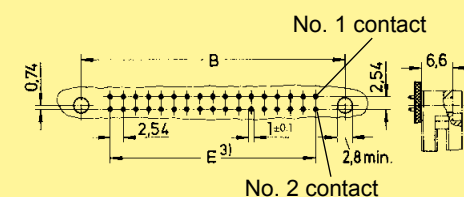

1) No polarization slot for 6, 10 or 14 way male header

2) No polarization slot for 6 way male header

3) Pitch tolerance: ± 0.1

Number of contacts

6-64



Tape & Reel packaging

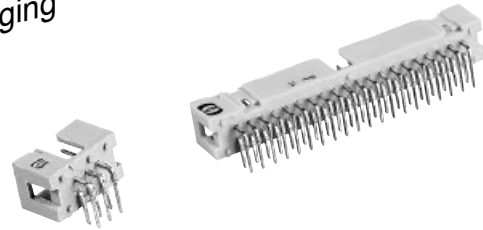

SMC low-profile male header, angled solder pins

Identification No. of contacts Part No. Drawing Dimensions in mm

SMC male header with angled solder pins

Length: 2.9 mm
Colour: Beige
Packaging: Carton

6	09 19 506	□ 323
10	09 19 510	□ 323
14	09 19 514	□ 323
16	09 19 516	□ 323
20	09 19 520	□ 323
26	09 19 526	□ 323
30	09 19 530	□ 323
34	09 19 534	□ 323
40	09 19 540	□ 323
50	09 19 550	□ 323
60	09 19 560	□ 323
64	09 19 564	□ 323

No. of contacts	A	B	E
6	15.2	12.78	2.54 x 2 = 5.08
10	20.3	17.86	2.54 x 4 = 10.16
14	25.4	22.94	2.54 x 6 = 15.24
16	27.9	25.48	2.54 x 7 = 17.78
20	33.0	30.56	2.54 x 9 = 22.86
26	40.6	38.18	2.54 x 12 = 30.48
30	45.72	43.26	2.54 x 14 = 35.56
34	50.8	48.34	2.54 x 16 = 40.64
40	58.4	55.96	2.54 x 19 = 48.26
50	71.3	68.66	2.54 x 24 = 60.96
60	84.0	81.36	2.54 x 29 = 73.66
64	89.1	86.44	2.54 x 31 = 78.74

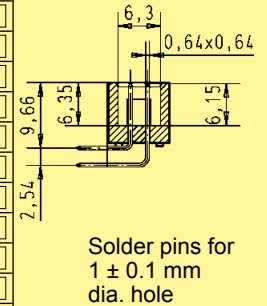

Colour: Beige
Packaging: Tape & Reel

6	09 19 506	□ 323 740
10	09 19 510	□ 323 740
14	09 19 514	□ 323 740
16	09 19 516	□ 323 740
20	09 19 520	□ 323 740
26	09 19 526	□ 323 740
30	09 19 530	□ 323 740
34	09 19 534	□ 323 740
40	09 19 540	□ 323 740

Vacuum plate for pick & place process

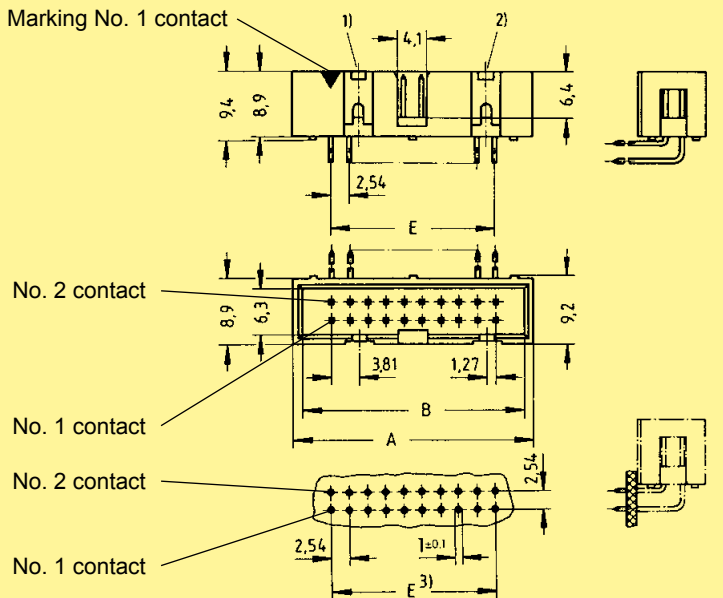

Colour: Black
Packaging: Tape & Reel

6	09 19 506	□ 323 741
10	09 19 510	□ 323 741
14	09 19 514	□ 323 741
16	09 19 516	□ 323 741
20	09 19 520	□ 323 741
26	09 19 526	□ 323 741
30	09 19 530	□ 323 741
34	09 19 534	□ 323 741
40	09 19 540	□ 323 741

Vacuum plate for pick & place process

For performance level 3 please specify digit 7
For performance level 2 please specify digit 6
S4 = 0.76 µm (30 µinch) Au or PdNi equivalent



Identification Part No. Drawing Dimensions in mm

Locking lever for female connector with strain relief in conjunction with low-profile male header

09 18 000 9905⁴⁾

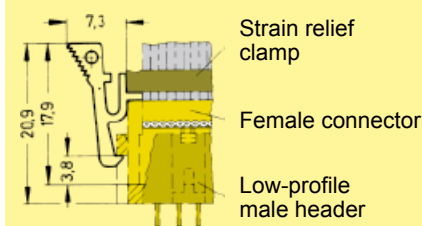

When the security of latching is required and space is a premium, these locking levers can be fitted onto the strain relief of the HARTING female connector.

* Not normally kept in stock

¹⁾ No polarization slot for 6, 10 or 14 way male header
²⁾ No polarization slot for 6 way male header

³⁾ Pitch tolerance: ± 0.1
⁴⁾ Order 2 per female connector

Number of contacts

6-64



Tape & Reel packaging

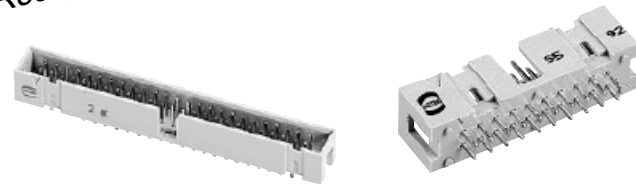

SMC low-profile male header, straight solder pins

Identification No. of contacts Part No. Drawing Dimensions in mm

SMC male header with straight solder pins

Length: 2.9 mm
Colour: Beige
Packaging: Carton

No. of contacts	Part No.	Drawing
6	09 19 506	324
10	09 19 510	324
14	09 19 514	324
16	09 19 516	324
20	09 19 520	324
26	09 19 526	324
30	09 19 530	324
34	09 19 534	324
40	09 19 540	324
50	09 19 550	324
60	09 19 560	324
64	09 19 564	324

No. of contacts	A	B	E
6	15.2	12.78	2.54 x 2 = 5.08
10	20.3	17.86	2.54 x 4 = 10.16
14	25.4	22.94	2.54 x 6 = 15.24
16	27.9	25.48	2.54 x 7 = 17.78
20	33.0	30.56	2.54 x 9 = 22.86
26	40.6	38.18	2.54 x 12 = 30.48
30	45.72	43.26	2.54 x 14 = 35.56
34	50.8	48.34	2.54 x 16 = 40.64
40	58.4	55.96	2.54 x 19 = 48.26
50	71.3	68.66	2.54 x 24 = 60.96
60	84.0	81.36	2.54 x 29 = 73.66
64	89.1	86.44	2.54 x 31 = 78.74

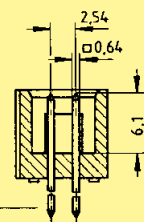

Solder pins for 1 ± 0.1 mm dia. hole

Colour: Beige
Packaging: Tape & Reel

No. of contacts	Part No.	Drawing
6	09 19 506	324 740
10	09 19 510	324 740
14	09 19 514	324 740
16	09 19 516	324 740
20	09 19 520	324 740
26	09 19 526	324 740
30	09 19 530	324 740
34	09 19 534	324 740
40	09 19 540	324 740

Vacuum plate for pick & place process

Colour: Black
Packaging: Tape & Reel

No. of contacts	Part No.	Drawing
6	09 19 506	324 741
10	09 19 510	324 741
14	09 19 514	324 741
16	09 19 516	324 741
20	09 19 520	324 741
26	09 19 526	324 741
30	09 19 530	324 741
34	09 19 534	324 741
40	09 19 540	324 741

Vacuum plate for pick & place process

For performance level 3 please specify digit 7
For performance level 2 please specify digit 6
S4 = 0.76 µm (30 µinch) Au or PdNi equivalent

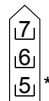

Marking No. 1 contact

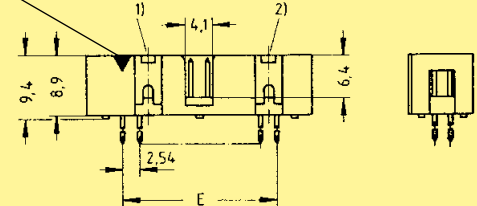

No. 2 contact

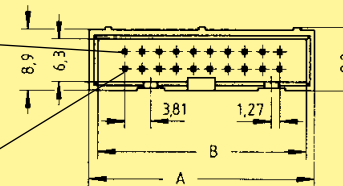

No. 1 contact

No. 2 contact

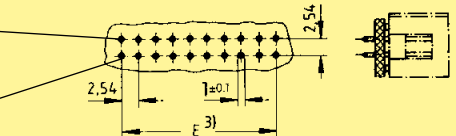

No. 1 contact

Identification Part No. Drawing Dimensions in mm

Locking lever for female connector with strain relief in conjunction with low-profile male header

09 18 000 9905⁴⁾

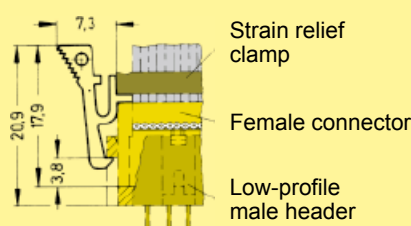

When the security of latching is required and space is a premium, these locking levers can be fitted onto the strain relief of the HARTING female connector.

* Not normally kept in stock

¹⁾ No polarization slot for 6, 10 or 14 way male header
²⁾ No polarization slot for 6 way male header

³⁾ Pitch tolerance: ± 0.1
⁴⁾ Order 2 per female connector

Accessories

Identification	Part No.	Drawing	Dimensions in mm
<p>Polarization key</p> <p>1) Part No. comprises 2 keys</p>	<p>09 18 500 9902¹⁾</p>		
<p>Locking lever (snaps into place, can be fitted whenever required)</p> <p>2) Order 2 per male header</p>	<p>Long: 09 19 000 9903²⁾</p> <p>Short: 09 19 000 9904²⁾</p>	<p>Long</p> <p>Short</p> <p>For use with female connector <u>with</u> strain relief clamp</p> <p>For use with female connector <u>without</u> strain relief clamp</p>	
<p>Fixing screws for 1.6 mm P.C. board</p> <p>3) Part No. comprises 50 pieces</p>	<p>09 18 000 9906³⁾</p>	<p>BZ 2.9x6.5 (DIN 7981 or DIN 7049)</p> <p>For connectors with part numbers 09 18 5xx x9xx: screwing torque 0.2 Nm 09 19 5xx x9xx: screwing torque 0.4 – 0.5 Nm</p> <p>Screw material: Steel (Inox A2)</p> <p>Plating: Nickel</p>	
<p>Coding system with loss of contact</p> <p>4) Part No. comprises 6 code pins</p>	<p>Code pin</p> <p>09 18 000 9901⁴⁾</p> <p>Removal tool for male contacts</p> <p>09 99 000 0133</p>	<p>To avoid cross-plugging adjacent connectors a coding system is required. A code pin is inserted into the appropriate cavity in the female connector. The corresponding male contact is removed by a special removal tool.</p>	

SMC technology

Tooling for press-in technology

Page

General information	30.02
Tooling compatible for complete interface connectors range	30.03
 Specific tooling	
<i>harmik</i> [®]	30.10
<i>D-Sub – S</i>	30.10
<i>SEK</i>	30.11

HARTING modular tooling adapted to customer specific needs



Hand bench press

- Easy to install
- No need of electrical or pneumatic power
- Ideal for prototyping and small series

Pneumatic press

- Easy handling
- Limitation of press-in force adjustable
- Ideal for medium series

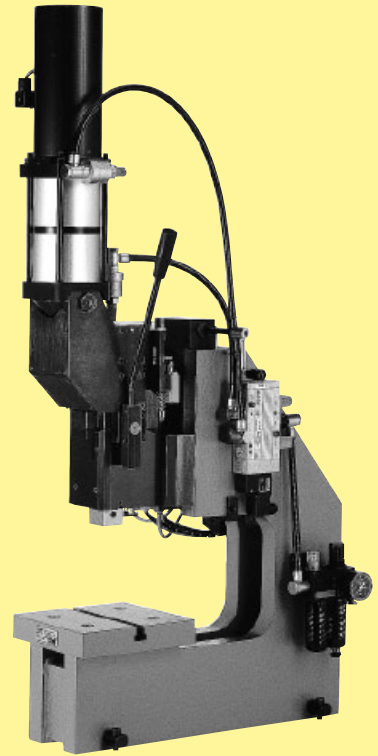

CPM *prestige*



The state of the art CPM press-in machine

- Fully programmable press-in machine
- Ideal for volume series



Bestseller **CPM *prestige*** with insertion removal station, adaptable to all HARTING press-in machines

Tooling compatible for complete interface connectors range

The **CPM prestige** press-in machine with a graphical user interface

The **CPM prestige** is a consequential development of the successful CPM 2001 press-in machines. The excellent design, supported by a wide range of tools presents a convenient, easy and comfortable way of processing backplanes and daughtercards. The machine is fully programmable and is supplied with a graphical user interface for control and visualisation of the complete process. The use of a microprocessor control allows the recognition and storage of different component heights, so that the pressing-in of different components is initiated simultaneously with only one button. The user-friendly touch-screen guides the user through the menu-orientated process controls.

The visualisation of the entire press-in process (the position of the connector, press-in forces etc.) allows the rapid recognition and eradication of the possible error sources. With the addition of a barcode reader (1D and 2D)¹⁾ the parameters of every pcb layout can be stored, recalled and loaded into the automated press-in programme. The extensive operation monitor functions simplify the service and support of the machine.

The machine employs the automatic switch-off system “autosense”, known worldwide for its reliability. The different connector types and the tolerances of the pcb are automatically recognised and taken into consideration at the press-in operation, thus maximising the process security.



Visual guiding system via touch monitor

Real photos of connectors and tools

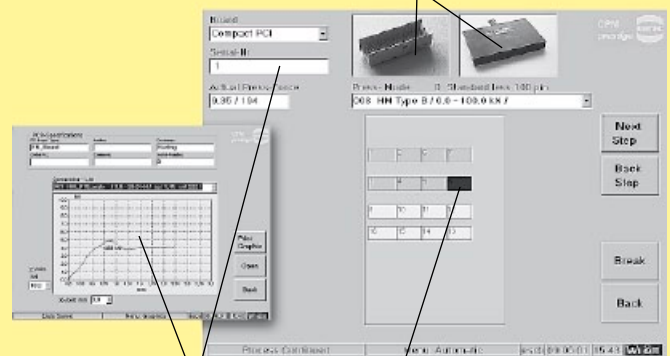

Process data

Layout with current position highlighted

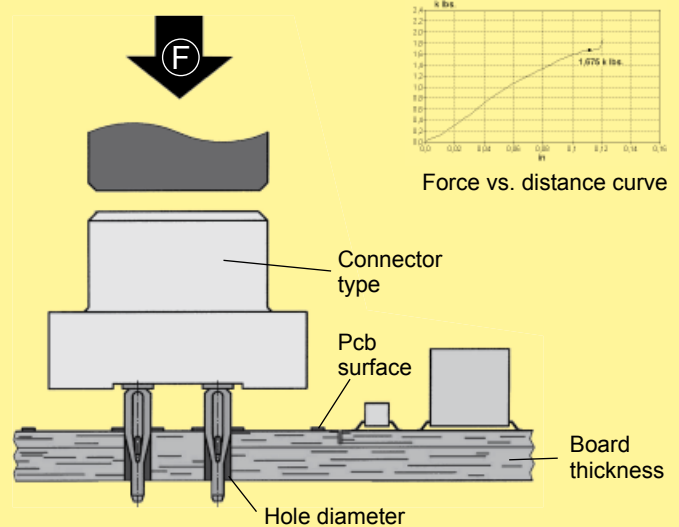

Shown are the four most considerable influences of the press-in process.

Tooling press-in

¹⁾ optional

Tooling compatible for complete interface connectors range

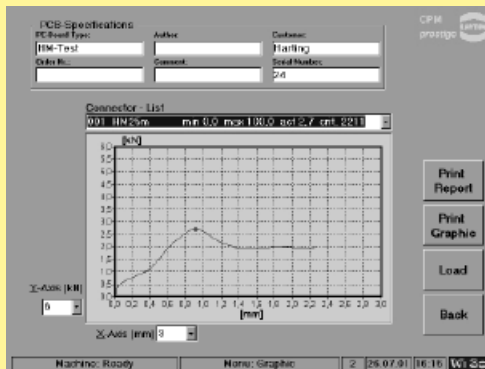

Quality control of press-in termination

The press-in force correlates with the diameter of the plated through hole and with the friction coefficient of the surface; therefore it can be used for a continuous monitoring of the process.

The retention force, as an indirect measure of the normal force, serves to qualify the process or random tests.



Part No. 09 89 040 0000

Technical characteristics

Drive	electro-mechanical, servo
Press-in force	100 kN
max. pcb dimensions	600 x 1000 mm
Floor space	1200 x 1150 mm
Weight	980 kg
Power supply	208 / 380 / 400 / 415 V
Consumption	< 1 kW
Colour	on request

CPM prestige
(incl. PC, control software, barcode reader, keyboard, touch screen)

Built-in features:

- Guiding rails (carbon/spring-loaded) for the secure positioning of the pcb
- Touch-screen and Industrial PC with UPS (uninterruptable power supply)
- Barcode reader for management ease of press-in programs
- All dimensions allow an easy integration into production lines

Process monitoring and quality assurance:

- Touch screen interface with graphical and verbal menus for all machine functions
- Autosense: automated press-in interruption at incorrect press-in forces
- Storage and validation of all press-in parameters via quality assurance software (press-in force tolerances)
- Continuous high-precision measurement and recording of press-in forces and distances
- Remote determination of errors and maintenance
- High flexibility through a modular tool range

Options:

- Rotatable tool changer
- Insertion removal station

Tooling compatible for complete interface connectors range

Insertion removal station



Power supply 220 V / 50 Hz
 Air pressure 6 bar (15-16 l/min.)

Part No. on request
 for pcb dimensions
 of max.
 710 mm x 540 mm

Bestseller **CPM prestige** with insertion removal station, adaptable to all HARTING press-in machines.

Principle:

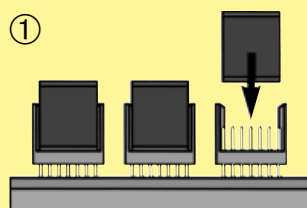

① Load all headers with inserts for **one press-in cycle**

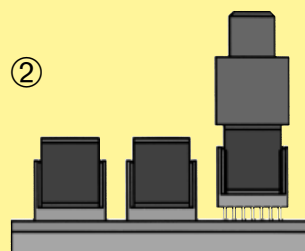

② Press-in all connectors with a flat die

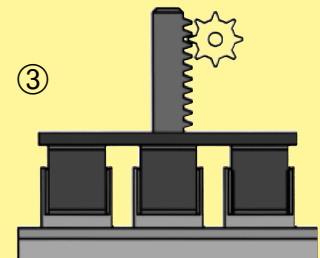

③ Position the magnetic plate

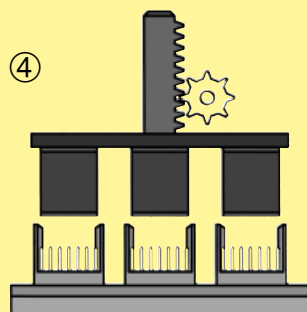

④ Remove all press-in inserts in one operation

Remove the processed pcb from the machine



⑤

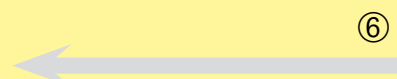

⑥ Move the next pre-assembled pcb to the press-in machine

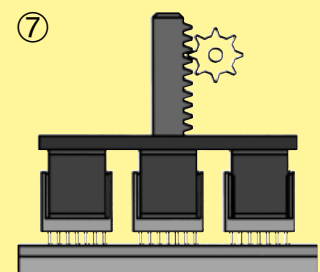

⑦ Load all headers in one operation

The insertion removal station has been developed both for the **CPM prestige** and the CPM 2001/s. It can additionally be used as stand alone equipment.

Tooling
press-in

Tooling compatible for complete interface connectors range

Today nearly all female connectors are designed for flat rock tooling. For every type of male connector specific tooling and a high degree of X-Y-process accuracy is required. Therefore HARTING offers press-in insert blocks that transfer all well known assembling advantages from female connectors to male headers.

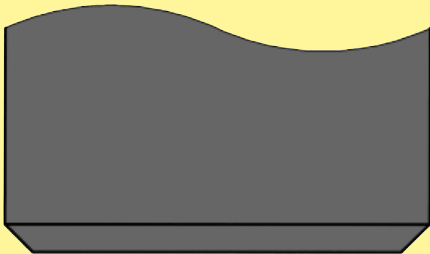

Advantages of press inserts

Robust tooling

No lateral force to pcb hole

No abrasion of the contact mating surface by the press tool

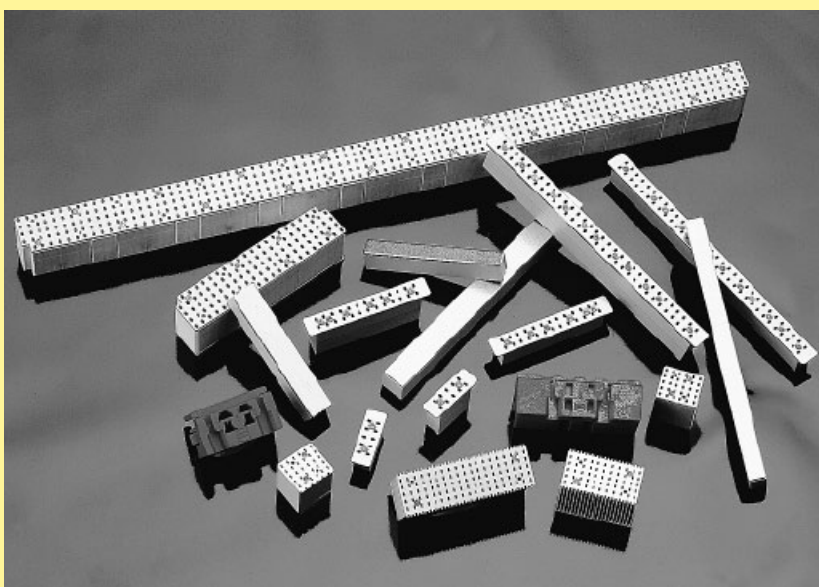
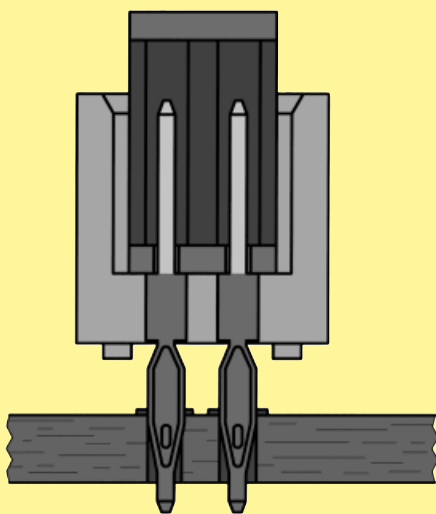

HARTING has already developed press-in inserts for all major male connector families on 2.54 mm, 2.5 mm and 2 mm pitches.

Inserts for any other special components can be developed on request.

The additional process for inserting and removing the press-in inserts can be efficiently done with the insertion removal station. This station removes all press-in inserts with a magnetic plate in one operation and inserts them into the next pre-assembled pcb with the necessary precision. (Principle see page 30.05).

The cycle time for loading all headers is between 4 and 6 seconds, independent from the amount of press-in inserts.

To load the inserts automatically means also that connectors assembled in a wrong way will be recognised and errors consequently prevented.

Tooling
press-in

Tooling compatible for complete interface connectors range

**Modular tooling system
for starting connector press-in**

The diversity of connector types with press-in terminations and varying termination styles make it necessary to have a simple, flexible tooling system that can be continuously updated.

The HARTING modular tooling system has significant advantages in terms of economic assembly of the many connector types with press-in terminations. The basic modules of the tooling system which will always be required are:

- Press
- Top tool
- Bottom tool
- Base plate

To increase automation and productivity the following modules may be added to the basic assembly:

- Guide frame with base plate for accurate positioning of the pcb up to a length of 600 mm
- Guide frame "Standard" for hand bench press and pneumatic press and pcb height of 123.5 up to 309.5 mm
- Guide frame "Long" for pneumatic press and pcb height of 123.5 up to 668.5 mm

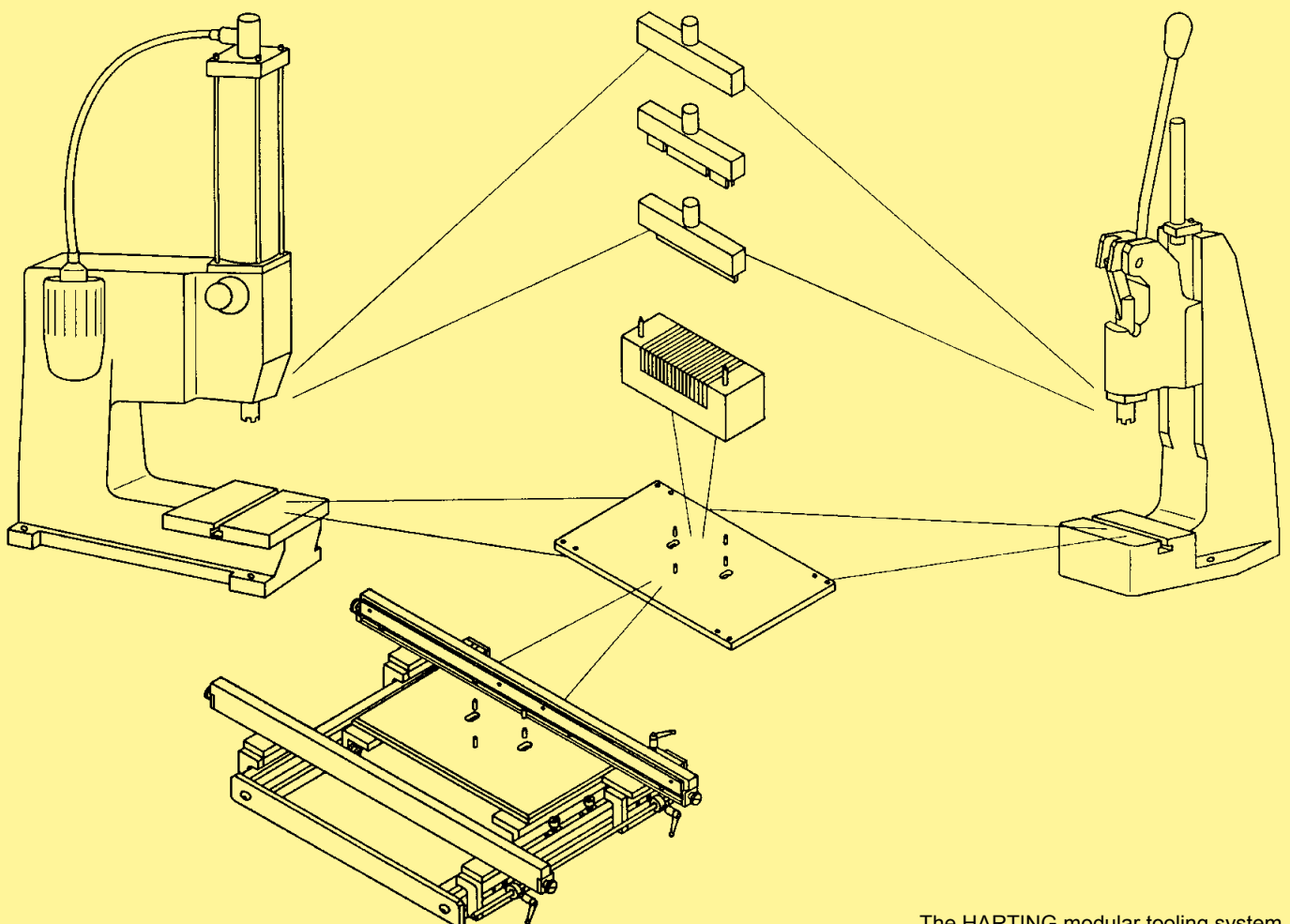

Tooling
press-in

Tooling compatible for complete interface connectors range

Handling indications

When setting up an assembly machine it is not necessary to set the working height of the press and adjust the base plate more than once. There is no need for further adjustments. All the other adaptations for various applications are performed efficiently and are reliant by various combinations of individual modules.

Positioning the bottom tool in relation to the top tool

The ram of the HARTING press is generally provided with a cross-shaped groove which accurately positions the top tool in steps of 90°.

Two guide pins position the bottom tool in relation to the top tool simply and accurately.

These guide pins cannot be used for positioning the pcb or the connector!

Two pairs of pins on the base plate locate the bottom tool in relation to the top tool in steps of 90°.

Bottom tool (narrow version)

In addition to the square bottom tool with multi-functional properties, HARTING offers the alternative of a narrow bottom tool for assembling connectors with straight press-in terminations. This tool supports the pcb within the press-in connector zone and therefore makes it possible to assemble connectors where electronic components are to be placed in close proximity.

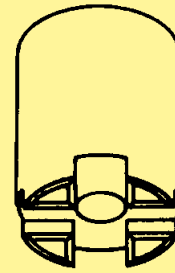

Ram with cross-shaped groove

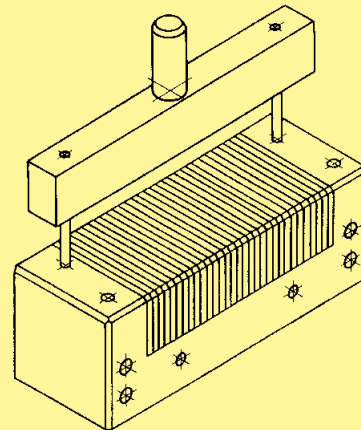

Positioning the bottom tool in relation to top tool

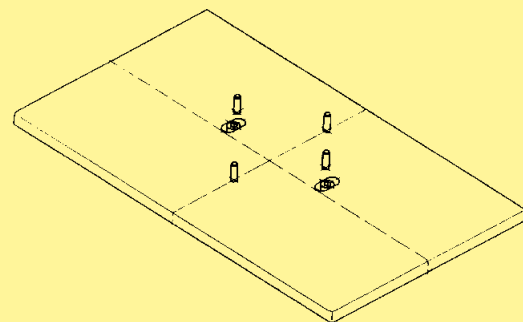

Base plate with pairs of location pins at 90°

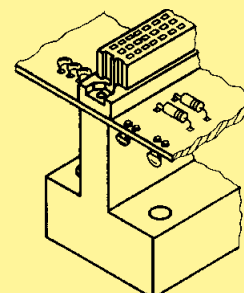

Narrow version of the bottom tool for special applications

Tooling compatible for complete interface connectors range

Identification	Part No.	Drawing	Dimensions in mm														
Hand bench press	09 99 000 0201	<p>Technical characteristics</p> <table border="0"> <tr> <td>Working stroke</td> <td>25 mm</td> </tr> <tr> <td>Press force</td> <td>15 kN max.</td> </tr> <tr> <td>Hole ø in the ram</td> <td>ø 10 mm</td> </tr> <tr> <td>Net weight</td> <td>approx. 23 kg</td> </tr> </table>	Working stroke	25 mm	Press force	15 kN max.	Hole ø in the ram	ø 10 mm	Net weight	approx. 23 kg							
Working stroke	25 mm																
Press force	15 kN max.																
Hole ø in the ram	ø 10 mm																
Net weight	approx. 23 kg																
Pneumatic press 40 kN	09 99 000 0282	<p>Technical characteristics</p> <table border="0"> <tr> <td>Total stroke</td> <td>48 mm</td> </tr> <tr> <td>Working stroke</td> <td>0-6 mm</td> </tr> <tr> <td>Press force</td> <td>40 kN max.</td> </tr> <tr> <td>Air pressure</td> <td>6 bar</td> </tr> <tr> <td>Hole ø in the ram</td> <td>ø 10.01 mm</td> </tr> <tr> <td>Net weight</td> <td>136 kg</td> </tr> <tr> <td>Power supply</td> <td>110 V / 220 V AC</td> </tr> </table>	Total stroke	48 mm	Working stroke	0-6 mm	Press force	40 kN max.	Air pressure	6 bar	Hole ø in the ram	ø 10.01 mm	Net weight	136 kg	Power supply	110 V / 220 V AC	
Total stroke	48 mm																
Working stroke	0-6 mm																
Press force	40 kN max.																
Air pressure	6 bar																
Hole ø in the ram	ø 10.01 mm																
Net weight	136 kg																
Power supply	110 V / 220 V AC																
Top tool	09 99 000 0197	<p>Top tool</p>															
Base plate	09 99 000 0255	<p>Bottom tool</p> <p>Base plate</p>															

Specific tooling for har-mik and D-Sub

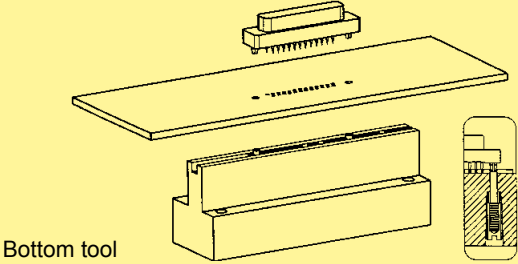
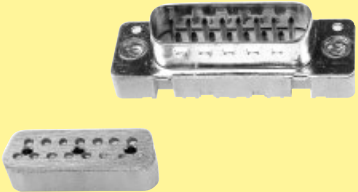
Identification	Part No.	
Bottom tool for har-mik	60 99 000 0031	
Press-out tool for har-mik	60 99 000 0032	
Bottom tool narrow for D-Sub Only one tool for all polarities, with or without grounding pins 9-37 way 50 way	09 99 000 0600 09 99 000 0523	 <p>Bottom tool</p>
Plastic with metal plate insert tool for D-Sub male 9 way 15 way 25 way	09 99 600 0709 09 99 600 0715 09 99 600 0725	
Other toolings on request		

Tooling
press-in

Specific tooling for SEK male standard

Identification	Part No.	Drawing	Dimensions in mm
<p>Top tool for SEK standard connectors</p> <p>10 way 14 way 16 way 20 way 26 way 34 way 40 way 50 way 60 way 64 way</p>	<p>09 99 000 0710 09 99 000 0714 09 99 000 0716 09 99 000 0720 09 99 000 0726 09 99 000 0734 09 99 000 0740 09 99 000 0750 09 99 000 0760 09 99 000 0764</p>	<p>X Length depends on number of contacts</p>	

Specific tooling for SEK male low-profile

Identification	Part No.	Drawing	Dimensions in mm
Bottom tool narrow for SEK	09 99 000 0256		
Top tool for SEK male low-profile connectors	6 way 09 99 000 0 06 10 way 09 99 000 0 10 14 way 09 99 000 0 14 16 way 09 99 000 0 16 20 way 09 99 000 0 20 26 way 09 99 000 0 26 34 way 09 99 000 0 34 40 way 09 99 000 0 40 50 way 09 99 000 0 50 60 way 09 99 000 0 60 64 way 09 99 000 0 64	Top tool including insert <p>X Length depends on number of contacts</p>	
Top tool including insert ➤ 4 Modular insert ➤ 5		Modular insert 	
Press-out tool for complete SEK male connectors with 5.5 mm terminations	09 99 000 0220		
Support block	09 99 000 0218		

Tooling for crimp technology

Page

General information	31.02
 Specific tooling	
<i>D-Sub – S</i>	31.04
<i>D-Sub – HD</i>	31.04
<i>D-Sub – M</i>	31.08
<i>D-Sub – InduCom</i>	31.12
<i>D-Sub – Crimp tools for screened hoods</i>	31.13

Crimp connection

A perfect crimp connection is gastight and therefore corrosion free. It is equivalent to a cold weld of the connected parts. For this reason, major features in achieving high quality crimp connections are the design of the crimping areas of the contact and of course the crimping tool itself. Wires to be connected must be carefully matched to the correct size of crimp contacts. If these basic requirements are met, users will be assured of highly reliable connections with a low contact resistance and a high resistance against corrosion.

The economical and technical advantages are:

- Constant contact resistance as a result of an unvariable crimp connection quality
- Corrosion free connections as a result of cold weld action
- Preparation of harnessing with crimp contacts already fitted
- More economic cable connection

Requirements for crimp connections are set out in DIN IEC 60 352-2.

Pull out force of stranded wire

The main criterion by which to judge the quality of a crimp connection is the retention force achieved by the wire conductor in the terminal section of the contact. DIN IEC 60 352, part 2, defines the extraction force in relation to the cross-section of the conductor. When fitted using HARTING crimping tools and subject to their utilization in an approved manner, our crimp connectors comply with the required extraction forces.



B shape cross section stamped contact



H shape cross section turned contact

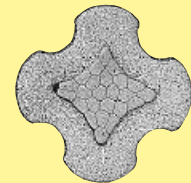

4 points shape cross section turned contact

Tensile strength of crimped connections

Conductor cross-section		Tensile strength
mm ²	AWG	N
0.05	30	6
0.08	28	11
0.12	26	15
0.14		18
0.22	24	28
0.25		32
0.32	22	40
0.5	20	60
0.75		85
0.82	18	90
1.0		108
1.3	16	135
1.5		150
2.1	14	200
2.5		230
3.3	12	275
4.0		310
5.3	10	355
6.0		360
8.4	8	370
10.0		380

Extract from DIN IEC 60 352-2, Amend. 2, table IV

Crimping tools

Crimping tools (hand operated or automatic) are carefully designed to guarantee a symmetrical deformation of the crimping area of the contact and the wire through the high pressure forming parts of the tool. The locator automatically engages the crimp contact and the wire at the correct point in the tool. The wire insulation can also be included as a secondary feature of some crimp contacts to care for additional mechanical strength.

The ratchet in the tool performs 2 functions:

- ① It prevents insertion of the crimp into the tool for crimping before the jaws are fully open
- ② It prevents the tool from being opened before the crimping action is completed

A quality crimp connection can be achieved with this crimping system.







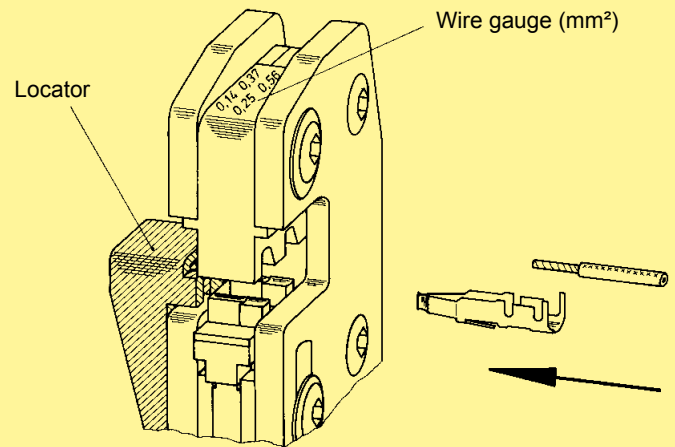

The adjacent sketches show important features of the HARTING hand crimping tool.

The HARTING automatic crimping tool uses bandoliered contacts.

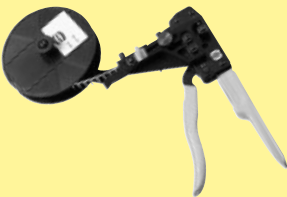
The machine strips insulation from the wire and then crimps the contact. Both the crimping area and the insulation support are independently adjustable to facilitate the use of any wire type with dimensions within the stated crimp capacity.

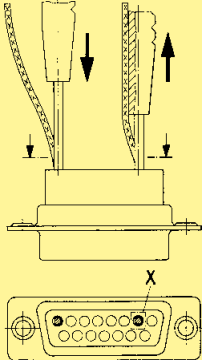

Tools for crimp termination

Identification	Part No.	Image	
Service crimp tool for single standard contacts for single high density contacts	09 99 000 0175 09 99 000 0535	 for standard contacts	 for high density contacts
HARTING-Crimp tool for 500 bandoliered standard contacts for 500 bandoliered high density contacts	09 99 000 0169 09 99 000 0597		
HARTING-Semi-automatic crimping device Main drive foot-operated 220 V / 50 Hz Crimping head for bandoliered standard contacts Reel holder for 10 000 contacts	09 99 000 0246 09 99 000 0253 09 99 000 0158	Wire gauge 0.09-0.56 mm ² (AWG 28-20) 	
Insertion and removal tool for single standard contacts for single high density contacts	09 99 000 0171 09 99 000 0513	 	
Assembly of crimp contacts After crimping the stranded wire to the contact using a hand tool or automatic crimping device, insert the contact into the chamber with the tool, working from the wiring side. You will hear the contacts snap home and to check that they are securely in place, give the wire a gentle pull.			
Removing crimp contacts Position the tool from the wiring side as shown in the diagram below and insert into the contact chamber. The contact can then easily be removed from the wiring side together with the wire itself and reinserted in a different chamber. The tool is designed for a maximum insulation diameter of Ø 1.7 mm.			
		Stripping length: 2.5 + 0.5 mm	

Tooling crimp

For all crimp tools: These tools are designed specifically for standard wires and not for solid wires.

Tools for crimp termination – D-Sub-S, D-Sub-HD

Identification

Part No.

Crimp tool
for turned male
and female contacts
AWG 28-18
4 indent crimp
in acc. to
MIL 22 520/2-01

09 99 000 0501



Contact Part No.	Gauge	Crimp tool selection No.
09 67 000 3x76	AWG 18, 20, 22	6 for AWG 18 and AWG 20, 5 for AWG 22
09 67 000 8x76	AWG 20, 22, 24	6
09 67 000 5x76	AWG 22, 24, 26	6
09 67 000 7x76	AWG 24, 26, 28	6

Locator for crimp tool
Details see table

09 99 000 0531



printing

USE WITH CONTACTS

HARTING
09 67 000 xxxx

	Selector					
AWG	18	20	22	24	26	28
18-22	6	6	5	-	-	-
20-24	-	6	6	6	-	-
22-26	-	-	6	6	6	-
24-28	-	-	-	6	6	6

Automated crimping machine type BK

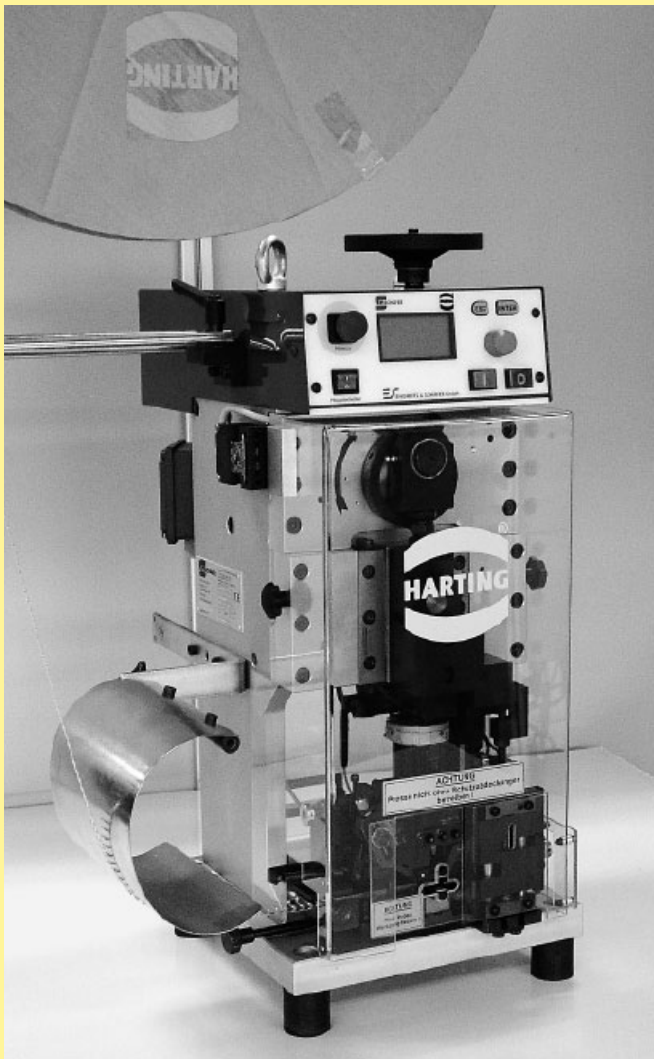

Main characteristics

- Smooth run through electronic brakes
- Hand wheel for manual adjustments
- Maintenance friendly through needle bearing rail
- Simple handling by quick change tool and stripper

Part No. 09 98 000 5000

Technical characteristics

Dimensions

Height	690 mm (1400 mm with a contact reel)
Width	350 mm
Depth	370 mm

Total weight 72 kg

Power supply 230 V, 50/60 Hz, 2.5 A

Consumption 0.75 kW

Motor speed 440 - 2000 rpm

Cable length 2 m incl. plug

Control SPS

Work cycle trigger Sensor

Work cycle 0.35 s for stripping and crimping

Illumination Integrated tool light

Stroke counter Daywise and fixed

Crimp force monitor BB07i

Crimping tool Quick change tool

Adjustable process parameters
 Crimping height on wire
 Crimping height on insulation
 Depth of insulation stripping
 Length of insulation stripping
 Wire retainer position
 Wire position in the crimp contact
 Band thrust

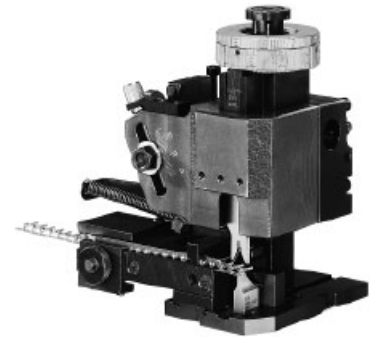

Identification	for use with	Part No.	Wire gauge [mm ²]	AWG	Insulation [Ø mm]
Crimping tool for DIN 41 612 connectors ¹⁾	contacts BC	09 98 000 3004	0.09 - 0.56	28 - 20	0.7 - 1.6
	contacts FC 1	09 98 000 3005	0.09 - 0.25	28 - 24	0.7 - 1.6
	FC 2	09 98 000 3006	0.14 - 0.56	26 - 20	0.8 - 2.3
	FC 3	09 98 000 3007	0.50 - 1.50	20 - 16	1.6 - 2.8
for D-Sub connectors ²⁾	standard contacts	09 98 000 3008 09 98 000 3009	0.09 - 0.25 0.25 - 0.56	28 - 24 24 - 20	0.7 - 1.4 0.9 - 1.7
	high density contacts	09 98 000 3012		26 - 24	0.8 - 1.4

¹⁾ 3.5 + 0.5 mm of insulation is stripped from the wire to be crimped
²⁾ 2.5 + 0.5 mm of insulation is stripped from the wire to be crimped





Tools for crimp termination

Identification	Part No.																																															
Hand crimp tool for signal contacts	09 99 000 0501	<p>printing</p> <p>USE WITH CONTACTS HARTING 09 67 000 xxxx</p> <table border="1"> <thead> <tr> <th colspan="2"></th> <th colspan="4">Selector</th> </tr> <tr> <th>AWG</th> <th></th> <th>18</th> <th>20</th> <th>22</th> <th>24</th> <th>26</th> <th>28</th> </tr> </thead> <tbody> <tr> <td>18-22</td> <td>6</td> <td>6</td> <td>5</td> <td>-</td> <td>-</td> <td>-</td> <td>-</td> </tr> <tr> <td>20-24</td> <td>-</td> <td>6</td> <td>6</td> <td>6</td> <td>-</td> <td>-</td> <td>-</td> </tr> <tr> <td>22-26</td> <td>-</td> <td>-</td> <td>6</td> <td>6</td> <td>6</td> <td>-</td> <td>-</td> </tr> <tr> <td>24-28</td> <td>-</td> <td>-</td> <td>-</td> <td>6</td> <td>6</td> <td>6</td> <td>-</td> </tr> </tbody> </table> <p>Wire gauge AWG 18 – 28</p>			Selector				AWG		18	20	22	24	26	28	18-22	6	6	5	-	-	-	-	20-24	-	6	6	6	-	-	-	22-26	-	-	6	6	6	-	-	24-28	-	-	-	6	6	6	-
			Selector																																													
AWG		18	20	22	24	26	28																																									
18-22	6	6	5	-	-	-	-																																									
20-24	-	6	6	6	-	-	-																																									
22-26	-	-	6	6	6	-	-																																									
24-28	-	-	-	6	6	6	-																																									
Die (To be ordered separately.)	09 99 000 0531																																															
Hand crimp tool for power contacts	09 99 000 0509																																															
Positioner for male and female contacts (To be ordered separately.)	09 99 000 0504																																															
Positioner for male contacts (To be ordered separately.)	09 99 000 0522	<table border="1"> <thead> <tr> <th>Contact Part No.</th> <th>Gauge</th> <th>Tool setting</th> </tr> </thead> <tbody> <tr> <td>09 69 182 x420</td> <td>AWG 16, 18, 20</td> <td>3 for AWG 16, 2 for AWG 18 and AWG 20</td> </tr> <tr> <td>09 69 282 x420</td> <td>AWG 16, 18, 20</td> <td>3 for AWG 16, 2 for AWG 18 and AWG 20</td> </tr> <tr> <td>09 69 182 x421</td> <td>AWG 12, 14</td> <td>5 for AWG 12 and 4 for AWG 14</td> </tr> <tr> <td>09 69 282 x421</td> <td>AWG 12, 14</td> <td>5 for AWG 12 and 4 for AWG 14</td> </tr> <tr> <td>09 69 182 x422</td> <td>AWG 10, 12</td> <td>7 for AWG 10 and 6 for AWG 12</td> </tr> <tr> <td>09 69 282 x422</td> <td>AWG 10, 12</td> <td>7 for AWG 10 and 6 for AWG 12</td> </tr> <tr> <td>09 69 182 x423</td> <td>AWG 8, 10</td> <td>7 for AWG 8 and 6 for AWG 10</td> </tr> <tr> <td>09 69 282 x423</td> <td>AWG 8, 10</td> <td>7 for AWG 8 and 6 for AWG 10</td> </tr> </tbody> </table>	Contact Part No.	Gauge	Tool setting	09 69 182 x420	AWG 16, 18, 20	3 for AWG 16, 2 for AWG 18 and AWG 20	09 69 282 x420	AWG 16, 18, 20	3 for AWG 16, 2 for AWG 18 and AWG 20	09 69 182 x421	AWG 12, 14	5 for AWG 12 and 4 for AWG 14	09 69 282 x421	AWG 12, 14	5 for AWG 12 and 4 for AWG 14	09 69 182 x422	AWG 10, 12	7 for AWG 10 and 6 for AWG 12	09 69 282 x422	AWG 10, 12	7 for AWG 10 and 6 for AWG 12	09 69 182 x423	AWG 8, 10	7 for AWG 8 and 6 for AWG 10	09 69 282 x423	AWG 8, 10	7 for AWG 8 and 6 for AWG 10																			
Contact Part No.	Gauge	Tool setting																																														
09 69 182 x420	AWG 16, 18, 20	3 for AWG 16, 2 for AWG 18 and AWG 20																																														
09 69 282 x420	AWG 16, 18, 20	3 for AWG 16, 2 for AWG 18 and AWG 20																																														
09 69 182 x421	AWG 12, 14	5 for AWG 12 and 4 for AWG 14																																														
09 69 282 x421	AWG 12, 14	5 for AWG 12 and 4 for AWG 14																																														
09 69 182 x422	AWG 10, 12	7 for AWG 10 and 6 for AWG 12																																														
09 69 282 x422	AWG 10, 12	7 for AWG 10 and 6 for AWG 12																																														
09 69 182 x423	AWG 8, 10	7 for AWG 8 and 6 for AWG 10																																														
09 69 282 x423	AWG 8, 10	7 for AWG 8 and 6 for AWG 10																																														
Positioner for female contacts (To be ordered separately.)	09 99 000 0521	<table border="1"> <thead> <tr> <th>Contact Part No.</th> <th>Gauge</th> <th>Tool setting</th> </tr> </thead> <tbody> <tr> <td>09 69 282 x821</td> <td>AWG 12, 14</td> <td>5 for AWG 12 and 4 for AWG 14</td> </tr> <tr> <td>09 69 282 x823</td> <td>AWG 8, 10</td> <td>7 for AWG 8 and 6 for AWG 10</td> </tr> </tbody> </table>	Contact Part No.	Gauge	Tool setting	09 69 282 x821	AWG 12, 14	5 for AWG 12 and 4 for AWG 14	09 69 282 x823	AWG 8, 10	7 for AWG 8 and 6 for AWG 10																																					
Contact Part No.	Gauge	Tool setting																																														
09 69 282 x821	AWG 12, 14	5 for AWG 12 and 4 for AWG 14																																														
09 69 282 x823	AWG 8, 10	7 for AWG 8 and 6 for AWG 10																																														
Hand crimp tool for coaxial contacts, solder/crimp version ¹⁾	09 99 000 0503																																															
Die (To be ordered separately.)	09 99 000 0508		<table border="1"> <thead> <tr> <th>Contact Part No.</th> <th>Cavity</th> </tr> </thead> <tbody> <tr> <td>09 69 181 x230</td> <td>B</td> </tr> <tr> <td>09 69 281 x230</td> <td>B</td> </tr> <tr> <td>09 69 181 x141</td> <td>C</td> </tr> <tr> <td>09 69 281 x141</td> <td>C</td> </tr> <tr> <td>09 69 181 x140</td> <td>B</td> </tr> <tr> <td>09 69 281 x140</td> <td>B</td> </tr> </tbody> </table>	Contact Part No.	Cavity	09 69 181 x230	B	09 69 281 x230	B	09 69 181 x141	C	09 69 281 x141	C	09 69 181 x140	B	09 69 281 x140	B																															
Contact Part No.	Cavity																																															
09 69 181 x230	B																																															
09 69 281 x230	B																																															
09 69 181 x141	C																																															
09 69 281 x141	C																																															
09 69 181 x140	B																																															
09 69 281 x140	B																																															
Die (To be ordered separately.)	09 99 000 0515	<table border="1"> <thead> <tr> <th>Contact Part No.</th> <th>Cavity</th> </tr> </thead> <tbody> <tr> <td>09 69 181 x143</td> <td>A</td> </tr> <tr> <td>09 69 281 x143</td> <td>A</td> </tr> </tbody> </table>	Contact Part No.	Cavity	09 69 181 x143	A	09 69 281 x143	A																																								
Contact Part No.	Cavity																																															
09 69 181 x143	A																																															
09 69 281 x143	A																																															
Die (To be ordered separately.)	09 99 000 0519	<table border="1"> <thead> <tr> <th>Contact Part No.</th> <th>Cavity</th> </tr> </thead> <tbody> <tr> <td>09 69 181 x233</td> <td>B</td> </tr> <tr> <td>09 69 281 x233</td> <td>B</td> </tr> </tbody> </table>	Contact Part No.	Cavity	09 69 181 x233	B	09 69 281 x233	B																																								
Contact Part No.	Cavity																																															
09 69 181 x233	B																																															
09 69 281 x233	B																																															

Tooling crimp

¹⁾ Only the outer ferrule is crimped (inner conductor is soldered)

Tools for crimp termination

Identification	Part No.										
<p>Hand crimp tool for coaxial contacts, crimp/crimp version¹⁾, suitable for inner contact</p>	09 99 000 0501										
<p>Inner contact die (To be ordered separately.)</p>	09 99 000 0507	 <table border="1" data-bbox="1046 562 1390 913"> <thead> <tr> <th>Contact Part No.</th> </tr> </thead> <tbody> <tr><td>09 69 182 x140</td></tr> <tr><td>09 69 282 x140</td></tr> <tr><td>09 69 182 x230</td></tr> <tr><td>09 69 282 x230</td></tr> <tr><td>09 69 182 x232</td></tr> <tr><td>09 69 282 x232</td></tr> <tr><td>09 69 182 x233</td></tr> <tr><td>09 69 282 x233</td></tr> </tbody> </table>	Contact Part No.	09 69 182 x140	09 69 282 x140	09 69 182 x230	09 69 282 x230	09 69 182 x232	09 69 282 x232	09 69 182 x233	09 69 282 x233
Contact Part No.											
09 69 182 x140											
09 69 282 x140											
09 69 182 x230											
09 69 282 x230											
09 69 182 x232											
09 69 282 x232											
09 69 182 x233											
09 69 282 x233											
<p>Hand crimp tool for coaxial contacts, crimp/crimp version¹⁾, suitable for outer ferrule</p>	09 99 000 0503										
<p>Outer contact die (To be ordered separately.)</p>	09 99 000 0508	 <table border="1" data-bbox="1046 1411 1390 1556"> <thead> <tr> <th>Contact Part No.</th> <th>Cavity</th> </tr> </thead> <tbody> <tr><td>09 69 182 x140</td><td rowspan="2">B</td></tr> <tr><td>09 69 282 x140</td></tr> <tr><td>09 69 182 x230</td><td rowspan="2">B</td></tr> <tr><td>09 69 282 x230</td></tr> </tbody> </table>	Contact Part No.	Cavity	09 69 182 x140	B	09 69 282 x140	09 69 182 x230	B	09 69 282 x230	
Contact Part No.	Cavity										
09 69 182 x140	B										
09 69 282 x140											
09 69 182 x230	B										
09 69 282 x230											
<p>Outer contact die (To be ordered separately.)</p>	09 99 000 0518	<table border="1" data-bbox="1046 1624 1390 1709"> <thead> <tr> <th>Contact Part No.</th> <th>Cavity</th> </tr> </thead> <tbody> <tr><td>09 69 182 x232</td><td rowspan="2">A</td></tr> <tr><td>09 69 282 x232</td></tr> </tbody> </table>	Contact Part No.	Cavity	09 69 182 x232	A	09 69 282 x232				
Contact Part No.	Cavity										
09 69 182 x232	A										
09 69 282 x232											
<p>Outer contact die (To be ordered separately.)</p>	09 99 000 0519	<table border="1" data-bbox="1046 1780 1390 1865"> <thead> <tr> <th>Contact Part No.</th> <th>Cavity</th> </tr> </thead> <tbody> <tr><td>09 69 182 x233</td><td rowspan="2">B</td></tr> <tr><td>09 69 282 x233</td></tr> </tbody> </table>	Contact Part No.	Cavity	09 69 182 x233	B	09 69 282 x233				
Contact Part No.	Cavity										
09 69 182 x233	B										
09 69 282 x233											

¹⁾ Both inner and outer conductor are crimped

Tools for crimp termination

Identification

Part No.

Hand crimp tool
for **high voltage**
contacts

09 99 000 0501



Die for male contacts
(To be ordered
separately.)

09 99 000 0507

Contact Part No.	Gauge	Tool setting
09 69 182 2550	AWG 24, 26, 28, 30	5 for AWG 24 and 26, 4 for AWG 28 and 3 for AWG 30
09 69 282 2550	AWG 24, 26, 28, 30	5 for AWG 24 and 26, 4 for AWG 28 and 3 for AWG 30

Die for female contacts
(To be ordered
separately.)

09 99 000 0533



Insertion and
extraction tool
for **signal** contacts

09 99 000 0511



Extraction tool
for **coaxial, power**
and **high voltage**
contacts

09 99 000 0512



1. Strip the wire.

2. Attach the sleeve and inner conductor.

3. Crimp the inner conductor.



4. Snap the inner conductor into the contact.

5. Tap the shield on.

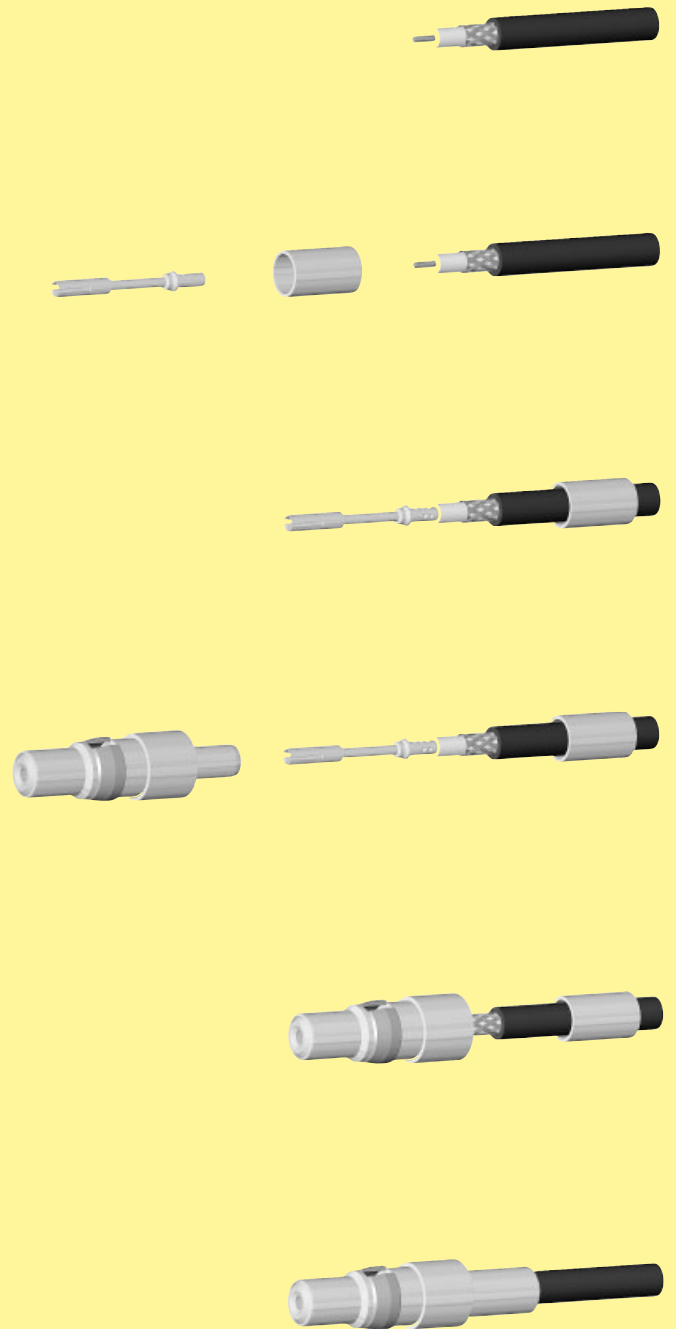
6. Slide the sleeve forwards and crimp.

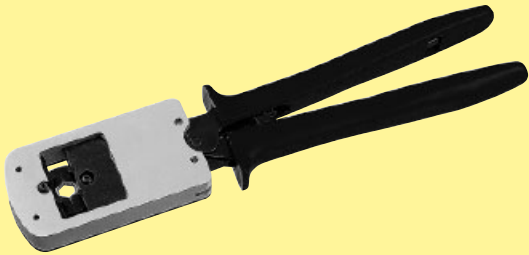

Tools for crimp termination

Identification	Part No.																					
Hexagonal head screwdriver for hoods with hexagonal screws	61 03 600 0021																					
Crimp tool for flange and ferrule	61 03 600 0020	 <table border="1" data-bbox="743 790 871 1440"> <thead> <tr> <th>Width of hexagonal nut [mm]</th> </tr> </thead> <tbody> <tr><td>5.0</td></tr> <tr><td>5.5</td></tr> <tr><td>6.0</td></tr> <tr><td>6.5</td></tr> <tr><td>7.0</td></tr> <tr><td>7.5</td></tr> <tr><td>8.0</td></tr> <tr><td>8.5</td></tr> <tr><td>9.0</td></tr> <tr><td>9.5</td></tr> <tr><td>10.0</td></tr> <tr><td>10.5</td></tr> <tr><td>11.0</td></tr> <tr><td>11.5</td></tr> <tr><td>12.0</td></tr> <tr><td>12.5</td></tr> <tr><td>13.0</td></tr> <tr><td>13.5</td></tr> <tr><td>14.0</td></tr> </tbody> </table>	Width of hexagonal nut [mm]	5.0	5.5	6.0	6.5	7.0	7.5	8.0	8.5	9.0	9.5	10.0	10.5	11.0	11.5	12.0	12.5	13.0	13.5	14.0
Width of hexagonal nut [mm]																						
5.0																						
5.5																						
6.0																						
6.5																						
7.0																						
7.5																						
8.0																						
8.5																						
9.0																						
9.5																						
10.0																						
10.5																						
11.0																						
11.5																						
12.0																						
12.5																						
13.0																						
13.5																						
14.0																						
Inserts for crimp tool	61 03 000 0179 61 03 000 0180 61 03 000 0098 61 03 000 0099 61 03 000 0100 61 03 000 0101 61 03 000 0102 61 03 000 0103 61 03 000 0104 61 03 000 0105 61 03 000 0174 61 03 000 0172 61 03 000 0168 61 03 000 0169 61 03 000 0175 61 03 000 0176 61 03 000 0177 61 03 000 0178 61 03 000 0173																					
Mounting tool for flange for D-Sub hoods (9-37 contacts) for D-Sub hoods (50 contacts)	61 03 600 0017 61 03 600 0018																					
Insertion and removal tool for contacts	09 99 000 0171																					

Tooling
crimp

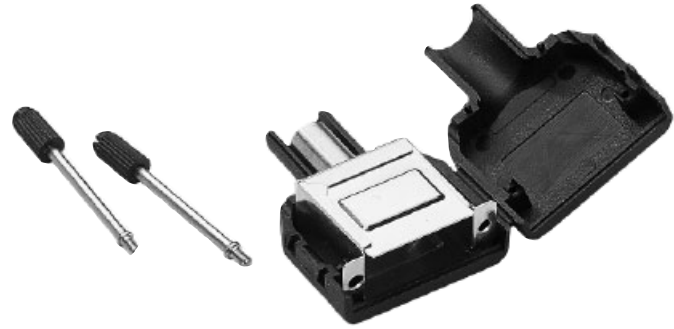

Tool / Assembly instructions

Identification	No. of contacts	Part No.	Drawing	Dimensions in mm
Crimp tool for screened hoods		09 99 000 0233		
Crimp tool dies	9	09 99 000 0235		
	15	09 99 000 0235		
	25	09 99 000 0236		
	37	09 99 000 0237		

Assembly instructions for screened hoods

Place the metal screen part (A) on the cable. Prepare the cable for termination.

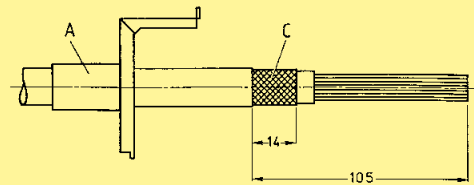

Place the inner ferrule (B) between conductors and the outer braid (C).

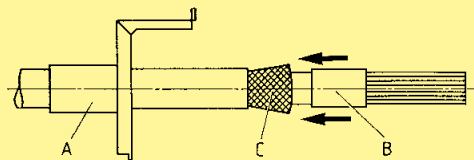

Terminate the D-Sub connector. Put the metal screen part (A) over the braid and crimp directly over the inner ferrule, ensuring that the correct crimp tool die is used. Slide in the other metal screen part (D).

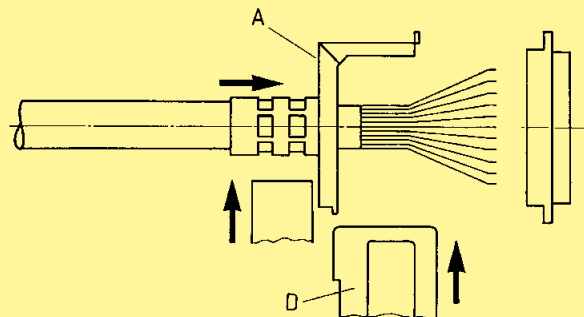

Push back the terminated connector into the assembled screen.

Put the assembled connector, screen and knurled screws into the thermoplastic hood and snap closed.

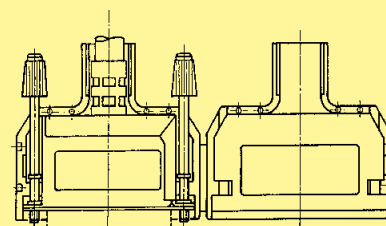





Tooling
crimp

Tooling for IDC technology

Page

harlink®	32.02
harmik®	32.02
D-Sub – S	32.05
SEK	32.06

Tools

Identification	Part No.	Drawing	Dimensions in mm
Crimping hand tool for shell cable entry	27 99 000 0001	 	<p>A manual for the <i>har-link</i>® cable free connector assembly is available in our online catalogue <i>HARKIS</i>® or on demand at your local HARTING representative</p>

Tools for insulation displacement termination for Pin and socket and Bellows range





Selection chart for hand assembly

for connector	Hand cable aligner	Head and table	Hand press
Male Pin and socket 60 03 ... 5200 60 03 ... 5205 60 03 ... 5210 60 03 ... 5215 60 03 ... 5220	60 99 000 0011	60 99 000 0010	60 99 000 0007
Male Bellows 60 13 ... 5200 60 13 ... 5205 60 13 ... 5215	60 99 000 0017	60 99 000 0016	

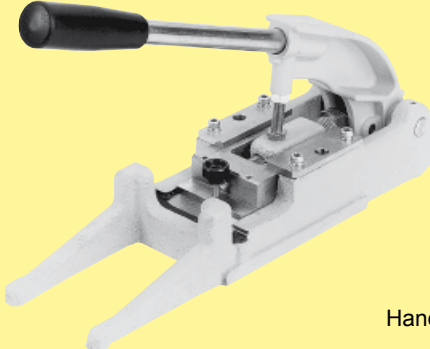

Number of contacts

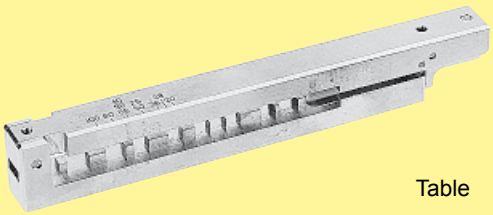
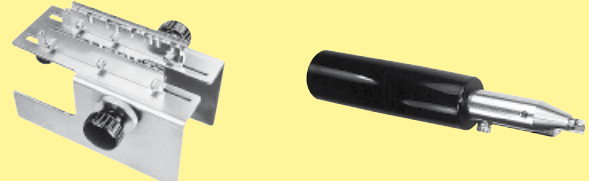
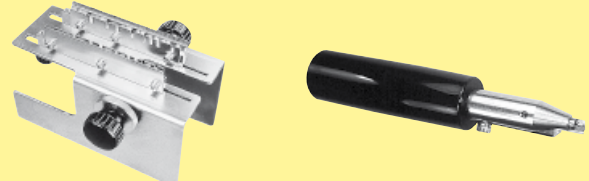
Tooling
IDC

Tools for insulation displacement termination

Identification	Part No.	
Hand press	60 99 000 0007	 <p>Hand press</p>
Head and table for male Pin and socket connector	60 99 000 0010	 <p>Head</p>
Head and table for male Bellows connector	60 99 000 0016	 <p>Table</p>
Hand cable aligner and press cutter for Pin and socket and female Bellows connector	60 99 000 0011	
Hand cable aligner and press cutter for male Bellows connector	60 99 000 0017	
Press cutter	60 99 000 0038	  <p>A manual for the <i>har-mik</i>® connector and cable assembly is available in our online catalogue <i>HARKIS</i>® or on demand at your local HARTING representative.</p>

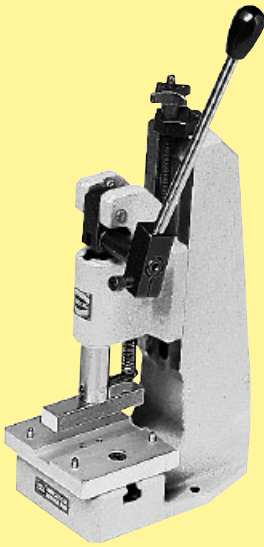
Tools for insulation displacement termination

Identification	Part No.	Drawing	Dimensions in mm
<p>Bench press for termination of insulation displacement connectors</p>	<p>09 99 000 0114</p>		
<p>Cabling tool for termination of flat cables</p>	<p>60 99 000 0034</p>		
<p>Cable cutter for flat cables</p>	<p>09 99 000 0116</p>		
<p>Spare parts Blade Cutting plate</p>	<p>09 99 000 0179 09 99 000 0180</p>		

Tools for insulation displacement termination

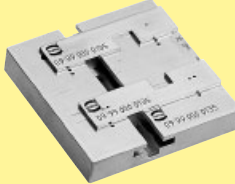
Identification	Part No.	Drawing	Dimensions in mm
Bench press for termination of insulation displacement connectors	09 99 000 0114		
Cabling tool for termination of flat cables	09 99 000 0135		
Insert for termination of 37 pole male connectors	09 99 600 0201		
Hand tool with base plates (included in tool kit) for termination of insulation displacement connectors	09 99 000 0149		
Cable cutter for flat cables	09 99 000 0116		
Spare parts Blade Cutting plate	09 99 000 0179 09 99 000 0180		

Tools for insulation displacement termination

Identification	Part No.	Drawing	Dimensions in mm	
<p>Bench press for termination of insulation displacement connectors</p>	09 99 000 0114			
<p>Cabling tool for termination of flat cables suitable for ...</p>				
<p>female</p>	09 99 000 0115			
<p>DIP</p>	09 99 000 0134			
<p>Pcb, 2 rows</p>	09 99 000 0131			
<p>Pcb, 4 rows</p>	09 99 000 0130			
<p>DIN 41612</p>	09 99 000 0150			
<p>Hand tool with base plates (included in tool kit) for termination of insulation displacement connectors suitable for ...</p>				
<p>female</p>	09 99 000 0149			
<p>DIP</p>				
<p>Pcb, 2 rows</p>				
<p>DIN 41612</p>				
<p>Cable cutter for flat cables</p>	09 99 000 0116			
<p>Spare parts</p>				
<p>Blade</p>	09 99 000 0179			
<p>Cutting plate</p>	09 99 000 0180			

Cables and cable assemblies

Page

harlink®	40.02
harmik®	40.03
D-Sub and SEK	40.08

Cables for insulation displacement termination

Identification	No. of pairs	Part No.	
		Standard version	Halogen free version with screened pairs
Twisted pair cable with braid shield AWG 28 AWG 30 Length per reel: 100 m	5	60 90 005 6010	60 90 005 6009
	10	60 90 010 6010	
	13	60 90 013 6010	
	18	60 90 018 6010	
	25	60 90 025 6010	
	34	60 90 034 6010	
	50	60 90 050 6010	

Drawing

No. of pairs	Outside diameter	
	Nominal	
5	5.4	
10	6.6	
13	6.8	
18	7.5	
25	8.5	
34	8.9	
50	11.1	

No. of pairs	Outside diameter
5	5.5 ± 0.3

Dimensions in mm

	Standard version	Halogen free version with screened pairs
	Number of pairs	5, 10, 13, 18, 25, 34, 50
Voltage rating	30 V (style UL 2789)	100 V
Maximum conductor resistance (20 °C)	233 Ω/km	350 Ω/km
Minimum insulation resistance (20 °C)	1 MΩ/km	10 GΩ/km
Nominal differential impedance (TDR)	85 Ω	95 Ω ± 5 Ω
Nominal differential capacitance (1 kHz)	110 pF/m	45 pF/m
Propagation velocity	55 %	
Temperature range	- 20 °C ... + 105 °C	- 25 °C ... + 80 °C
Cable materials		
Conductor	7 x 0.13 mm stranded tinned copper	7 x 0.1 mm stranded tinned copper
Insulation (except 50 pairs) (for 50 pairs)	PVC Ø 0.62 mm PVC Ø 0.67 mm	Polypropylene Ø 0.74 mm
Shield	Tinned copper braid, covering ≥ 80 %	Tinned copper braid, covering ≥ 65 %
Jacket	PVC	FRNC
Flammability rating	Flame tested as per UL style 2789	
Sheath marking	AWM 2789 60°C 30V	AWM 21283 80°C 30V VW1

Thin print: Standard version
Italic print: Halogen free version

Cables for insulation displacement termination

Identification	No. of wires	Part No.
Flat cable for IDC connector Pitch 0.635 mm AWG 30		
Length per reel: 100 ft 30.48 m	50 68	60 90 050 6008 60 90 068 6008

Drawing Dimensions in mm

The drawing shows a cross-section of a flat cable with four conductors. Dimension 'a' is the total width, 'b' is the pitch between conductors, 'c' is the width of the conductor group, and 'd' is the conductor diameter.

	a ± 0.25	b ± 0.05	c ± 0.2	d ± 0.05
50	31.75	0.635	31.12	0.68
68	43.20	0.635	42.55	0.68

The tolerance b is not cumulative

Technical characteristics	
Number of wires	50, 68
Voltage rating	150 V
Current rating	1.5 A max. per conductor
Impedance	75 Ω
Nominal differential capacitance (1 kHz)	90 pF/m
Pitch	0.635 mm
UL style	2678
Cables Temperature range	- 30 °C ... + 105 °C
Materials	
Conductor	7 x 0.102 mm regular tinning or Z-bonding AWG 30
Insulation	PVC

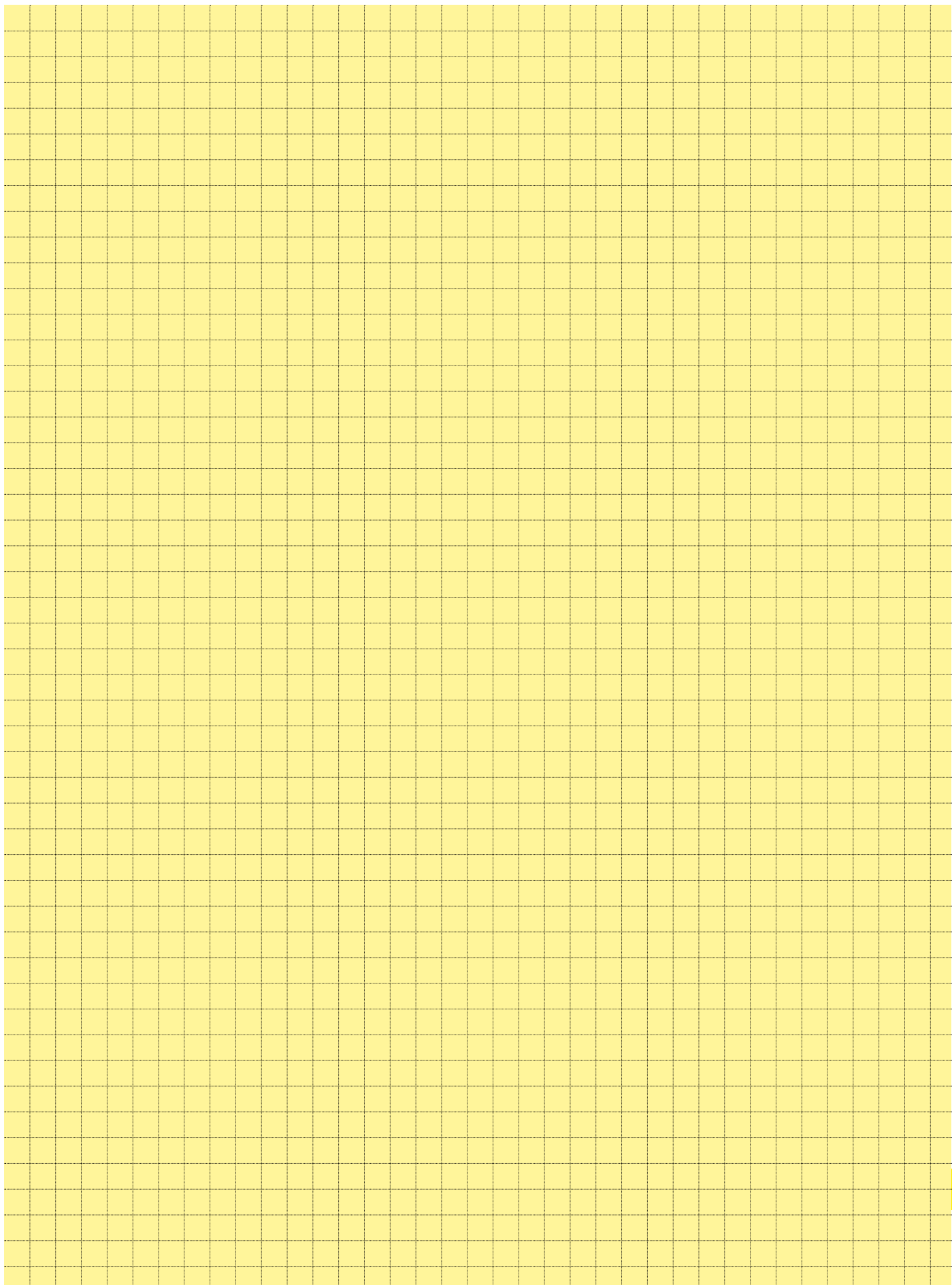



Cable assemblies

Identification	Part No.	Drawing	Dimensions in mm
----------------	----------	---------	------------------

Cable assembly D-Sub HD 78 pole

Hood: shielded plastic hood with side entry, screw 4-40 UNC
 Cable: 39 twisted pairs, AWG 26, double shielded, PVC
 Wiring: 1:1

Length: L = 0.5 m
 L = 1.0 m
 L = 2.0 m
 L = 5.0 m
 L = 10.0 m
 L = 20.0 m

33 56 212 0050 028
 33 56 213 1000 002
 33 56 213 2000 016
 33 56 212 0500 029
 33 56 212 1000 030
 33 56 212 2000 031

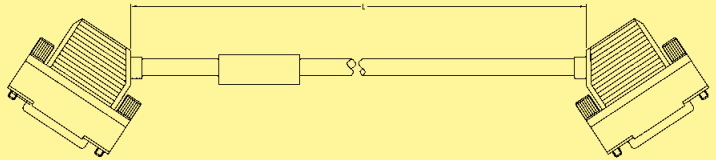

Cable assembly D-Sub HD 44 pole

Hood: shielded plastic hood with side entry, screw 4-40 UNC
 Cable: 22 twisted pairs, AWG 26, double shielded, PVC
 Wiring: 1:1

Length: L = 0.5 m
 L = 1.0 m
 L = 1.5 m
 L = 2.0 m
 L = 5.0 m
 L = 10.0 m

33 56 213 0500 023
 33 56 213 1000 024
 33 56 213 1500 022
 33 56 213 2000 025
 33 56 213 5000 026
 33 56 212 1000 027

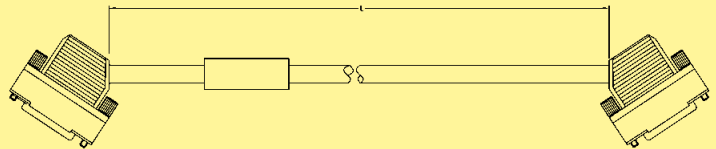

Cable assembly D-Sub HD 44 pole

Hood: metal hood with top entry, screw 4-40 UNC
 Cable: 24 twisted pairs, AWG 26, double shielded, PVC
 Wiring: 1:1

Length: L = 0.5 m
 L = 1.0 m
 L = 5.0 m
 L = 10.0 m
 L = 20.0 m

33 56 212 0050 032
 33 56 212 0100 033
 33 56 212 0500 034
 33 56 212 1000 035
 33 56 212 2000 036

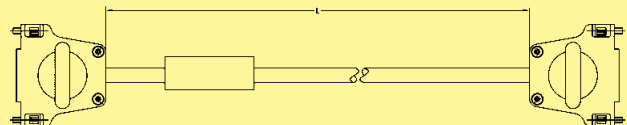

Cables for insulation displacement termination

Identification	No. of contacts	Part No.	Drawing	Dimensions in mm			
Flat cable grey UL AWM-style 2651 CSA	6	09 18 006 700 □		Conductor material _____ Copper tinned Gauge _____ AWG 28/7 0.089 mm ² Voltage rating _____ 300 V _{r.m.s.} Current rating at 25 °C _____ 2.1 A max. Capacity unbalanced _____ 45.9 pF/m Impedance unbalanced _____ 105 Ω Propagation delay _____ 4.9 ns/m nominal Insulation material _____ PVC Temperature rating (operating) _____ -20 °C ... +105 °C Temperature rating (static) _____ -30 °C ... +105 °C Flammability rating _____ UL: VW-1 Insulation resistance _____ > 100 MΩ/km			
	9	09 18 009 700 □					
	10	09 18 010 700 □					
	14	09 18 014 700 □					
	15	09 18 015 700 □					
	16	09 18 016 700 □					
	18	09 18 018 700 □					
	20	09 18 020 700 □					
	24	09 18 024 700 □					
	25	09 18 025 700 □					
	26	09 18 026 700 □					
	28	09 18 028 700 □					
	30	09 18 030 700 □					
	34	09 18 034 700 □					
	37	09 18 037 700 □					
	40	09 18 040 700 □					
	50	09 18 050 700 □					
	60	09 18 060 700 □					
	64	09 18 064 700 □					
	Length per reel						
30.48 m (100 feet)	1						
100 m (328 feet)	4						
Flat cable grey non-halogenated UL style 21447 for VW-1	6	09 18 006 700 □ 900		Conductor material _____ Copper tinned Gauge _____ AWG 28/7 0.089 mm ² Voltage rating _____ 300 V _{r.m.s.} Current rating _____ 1.3 A Capacity unbalanced _____ 42.6 pF/m at 1 MHz Impedance unbalanced _____ 100 Ω Inductance _____ 0.56 μH/m Propagation delay _____ 4.8 ns/m Insulation material _____ Non-halogenated flame retardent Polyolefin Temperature rating _____ -40 °C ... +80 °C Insulation resistance _____ 10000 MΩ/km			
	9	09 18 009 700 □ 900					
	10	09 18 010 700 □ 900					
	14	09 18 014 700 □ 900					
	15	09 18 015 700 □ 900					
	16	09 18 016 700 □ 900					
	18	09 18 018 700 □ 900					
	20	09 18 020 700 □ 900					
	24	09 18 024 700 □ 900					
	25	09 18 025 700 □ 900					
	26	09 18 026 700 □ 900					
	28	09 18 028 700 □ 900					
	34	09 18 034 700 □ 900					
	37	09 18 037 700 □ 900					
	40	09 18 040 700 □ 900					
	50	09 18 050 700 □ 900					
	60	09 18 060 700 □ 900					
	64	09 18 064 700 □ 900					
	Length per reel						
	30.48 m (100 feet)	1					

Important: always store reel vertically

Cables for insulation displacement termination

Identification	No. of contacts	Part No.	Drawing	Dimensions in mm
Flat cable colour coded Length per reel 30.48 m (100 feet) UL AWM-style 2651	6	09 18 006 7005	<p>Colour code sequence (in 10 steps) brown, red, orange, yellow, green, blue, violet, grey, white, black</p> <p>Conductor material _____ Copper tinned Gauge _____ AWG 28/7 0.09 mm² Voltage rating _____ 300 V_{r.m.s.} Current rating at 25 °C _____ 2.1 A max. Conductor resistance _____ 221 mΩ/m Capacity unbalanced _____ 42.7 pF/m Impedance unbalanced _____ 105 Ω Inductance unbalanced _____ 0.68 μH/m Signal delay _____ 4.9 ns/m Insulation material _____ PVC Temperature rating (operating) _____ -20 °C ... + 105 °C Temperature rating (static) _____ -30 °C ... + 105 °C Flammability rating _____ UL: VW 1 Insulation resistance _____ 100 MΩ/km</p>	
	9	09 18 009 7005		
	10	09 18 010 7005		
	14	09 18 014 7005		
	15	09 18 015 7005		
	16	09 18 016 7005		
	18	09 18 018 7005		
	20	09 18 020 7005		
	24	09 18 024 7005		
	25	09 18 025 7005		
	26	09 18 026 7005		
	28	09 18 028 7005		
	30	09 18 030 7005		
	34	09 18 034 7005		
	37	09 18 037 7005		
	Flat cable twisted pair Length per reel 30.48 m (100 feet) UL AWM-style 20 130	10		09 18 010 7006
14		09 18 014 7006		
16		09 18 016 7006		
20		09 18 020 7006		
26		09 18 026 7006		
34		09 18 034 7006		
40		09 18 040 7006		
50		09 18 050 7006		
60		09 18 060 7006		
64		09 18 064 7006		

Cables for insulation displacement termination

Identification	No. of contacts	Part No.	Drawing	Dimensions in mm												
Round flat cable																
ø max.																
with screening (shielding)	9	09 18 009 70	<p>① Flat cable, AWG 28/7 ② Aluminium / Polyester tape (spiral wrap) ③ 85 % minimum coverage tinned copper braid ④ Outer jacket: black PVC</p>	6.86												
	10	09 18 010 70		6.86												
	14	09 18 014 70		7.37												
	15	09 18 015 70		7.62												
	16	09 18 016 70		7.87												
	20	09 18 020 70		8.38												
	25	09 18 025 70		9.14												
	26	09 18 026 70		9.14												
	34	09 18 034 70		10.16												
	37	09 18 037 70		10.41												
	40	09 18 040 70		10.92												
	50	09 18 050 70		12.19												
	60	09 18 060 70		13.21												
	64	09 18 064 70		13.46												
Length per reel																
30.48 m (100 feet)	07															
100 m (328 feet)	10*															
without screening (shielding)	9	09 18 009 70	<p>① Flat cable, AWG 28/7 ② Clear polyester ③ Outer jacket: black PVC</p>	6.35												
	10	09 18 010 70		6.35												
	14	09 18 014 70		6.60												
	15	09 18 015 70		6.86												
	16	09 18 016 70		7.11												
	20	09 18 020 70		7.62												
	25	09 18 025 70		8.38												
	26	09 18 026 70		8.38												
	34	09 18 034 70		9.40												
	37	09 18 037 70		9.65												
	40	09 18 040 70		10.16												
	50	09 18 050 70		11.43												
	60	09 18 060 70		12.45												
	64	09 18 064 70		12.70												
Length per reel																
30.48 m (100 feet)	08															
100 m (328 feet)	11*															
<table border="1"> <thead> <tr> <th>No. of contacts</th> <th>a</th> <th>b</th> <th>c</th> </tr> </thead> <tbody> <tr> <td>9 to 26</td> <td>19.05</td> <td>19.05</td> <td>38.10</td> </tr> <tr> <td>34 to 64</td> <td>38.10</td> <td>19.05</td> <td>57.15</td> </tr> </tbody> </table>					No. of contacts	a	b	c	9 to 26	19.05	19.05	38.10	34 to 64	38.10	19.05	57.15
No. of contacts	a	b	c													
9 to 26	19.05	19.05	38.10													
34 to 64	38.10	19.05	57.15													
<p>Conductor material _____ Copper tinned</p> <p>Gauge _____ AWG 28/7 0.089 mm²</p> <p>Voltage rating _____ 300 V_{r.m.s.}</p> <p>Conductor resistance _____ 225 mΩ/m</p> <p>Capacity unbalanced _____ 78.7 pF/m</p> <p>Impedance unbalanced _____ 75 Ω</p> <p>Signal delay _____ 5.25 ns/m nom.</p> <p>Insulation material _____ PVC</p> <p>Temperature rating _____ -20 °C ... + 105 °C</p> <p>Flammability rating _____ UL: VW 1</p> <p>Insulation resistance _____ 10⁴ MΩ/km</p>																

* Not normally kept in stock
Important: always store reels vertically

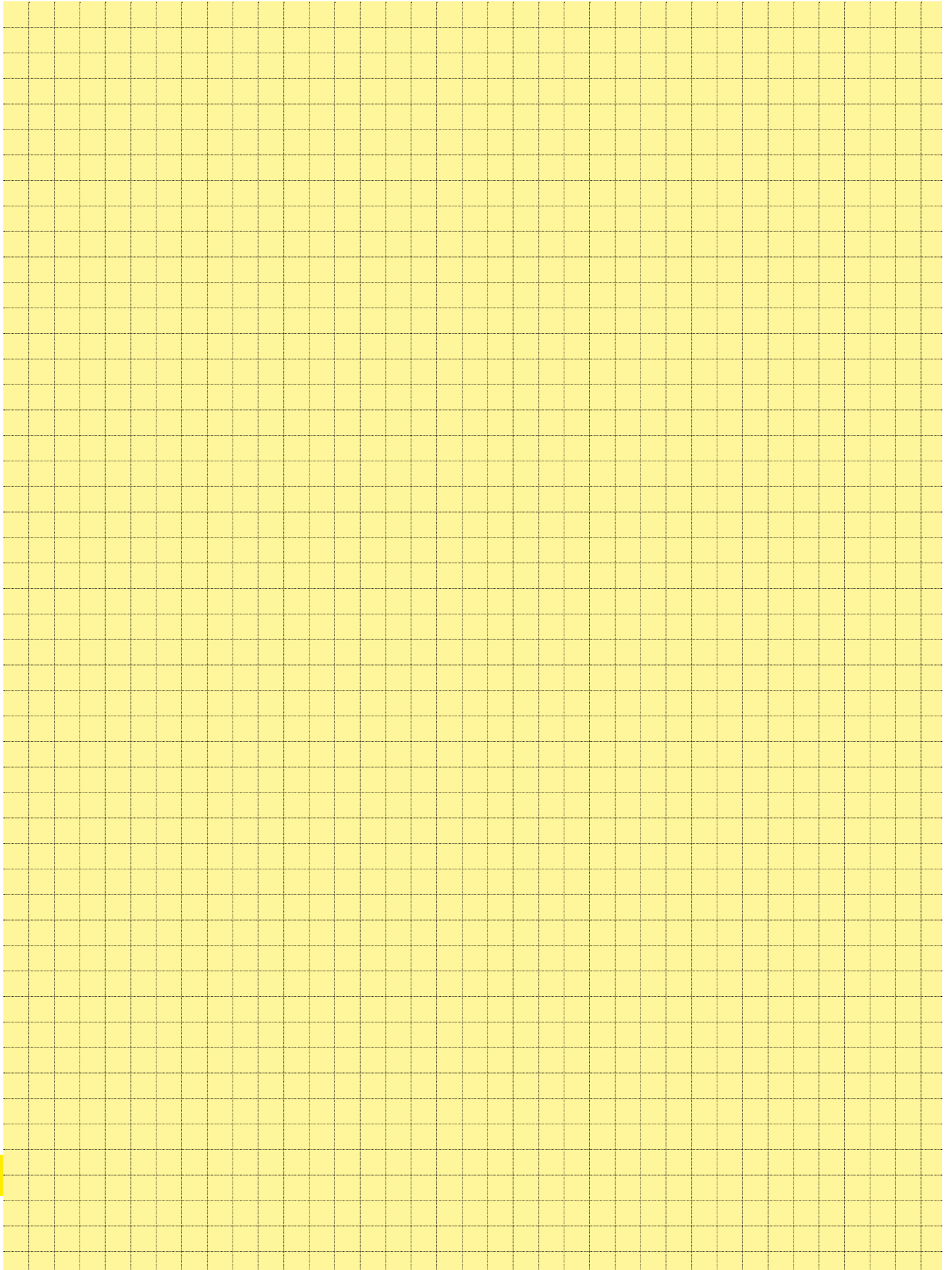

List of part numbers



Part No.	Page	Part No.	Page	Part No.	Page	Part No.	Page	Part No.	Page
09 02 264 6828	09.31	09 18 014 7001	40.11	09 18 026 7010	40.13	09 18 064 7007	40.13	09 18 506 5814	09.22
09 02 264 7828	09.31	09 18 014 7001 900	40.11	09 18 026 7011	40.13	09 18 064 7008	40.13	09 18 506 5901	09.06
		09 18 014 7004	40.11			09 18 064 7010	40.13	09 18 506 5902	09.08
		09 18 014 7005	40.12	09 18 028 7001	40.11	09 18 064 7011	40.13	09 18 506 5903	09.06
09 03 000 9940	09.31	09 18 014 7006	40.12	09 18 028 7001 900	40.11			09 18 506 5904	09.08
		09 18 014 7007	40.13	09 18 028 7004	40.11	09 18 104 9422	09.25	09 18 506 5906	09.18
09 03 264 6828	09.31	09 18 014 7008	40.13	09 18 028 7005	40.12	09 18 104 9622	09.25	09 18 506 5907	09.18
09 03 264 7828	09.31	09 18 014 7010	40.13					09 18 506 5911	09.06
		09 18 014 7011	40.13	09 18 030 7001	40.11	09 18 106 9422	09.25	09 18 506 5912	09.08
				09 18 030 7004	40.11	09 18 106 9622	09.25	09 18 506 5913	09.06
09 03 764 6828	09.31			09 18 030 7005	40.12			09 18 506 5914	09.08
		09 18 015 7001	40.11			09 18 108 9422	09.25	09 18 506 5916	09.18
		09 18 015 7001 900	40.11	09 18 034 7001	40.11	09 18 108 9622	09.25	09 18 506 5917	09.18
09 17 014 9622	09.29	09 18 015 7004	40.11	09 18 034 7001 900	40.11			09 18 506 5921	09.06
		09 18 015 7005	40.12	09 18 034 7004	40.11	09 18 110 9422	09.25	09 18 506 5922	09.08
		09 18 015 7007	40.13	09 18 034 7005	40.12	09 18 110 9622	09.25	09 18 506 5923	09.06
09 17 016 9622	09.29	09 18 015 7008	40.13	09 18 034 7006	40.12			09 18 506 5924	09.08
		09 18 015 7010	40.13	09 18 034 7007	40.13	09 18 114 9422	09.25	09 18 506 5926	09.18
09 17 024 9622	09.29	09 18 015 7011	40.13	09 18 034 7008	40.13	09 18 114 9622	09.25	09 18 506 5927	09.18
				09 18 034 7010	40.13			09 18 506 5953	09.12
09 17 028 9622	09.29	09 18 016 7001	40.11	09 18 034 7011	40.13	09 18 116 9422	09.25	09 18 506 5963	09.12
		09 18 016 7001 900	40.11			09 18 116 9622	09.25	09 18 506 5973	09.12
09 17 040 9622	09.29	09 18 016 7004	40.11	09 18 037 7001	40.11			09 18 506 6004	09.10
		09 18 016 7005	40.12	09 18 037 7001 900	40.11	09 18 120 9422	09.25	09 18 506 6014	09.10
		09 18 016 7006	40.12	09 18 037 7004	40.11	09 18 120 9622	09.25	09 18 506 6024	09.10
		09 18 016 7007	40.13	09 18 037 7005	40.12			09 18 506 6322	09.15
09 18 000 9901	09.16	09 18 016 7008	40.13	09 18 037 7007	40.13	09 18 124 9422	09.25	09 18 506 6323	09.14
09 18 000 9901	09.20	09 18 016 7010	40.13	09 18 037 7008	40.13	09 18 124 9622	09.25	09 18 506 6324	09.15
09 18 000 9901	09.23	09 18 016 7011	40.13	09 18 037 7010	40.13			09 18 506 6329	20.19
09 18 000 9901	22.32			09 18 037 7011	40.13	09 18 126 9422	09.25	09 18 506 6803	09.22
09 18 000 9903	09.16	09 18 018 7001	40.11			09 18 126 9622	09.25	09 18 506 6803 58U	09.22
09 18 000 9903	09.20	09 18 018 7001 900	40.11	09 18 040 7001	40.11			09 18 506 6804	09.22
09 18 000 9904	09.16	09 18 018 7004	40.11	09 18 040 7001 900	40.11	09 18 130 9422	09.25	09 18 506 6813	09.22
09 18 000 9904	09.20	09 18 018 7005	40.12	09 18 040 7004	40.11	09 18 130 9622	09.25	09 18 506 6813 58U	09.22
09 18 000 9905	09.14			09 18 040 7005	40.12			09 18 506 6814	09.22
09 18 000 9905	09.15	09 18 020 7001	40.11	09 18 040 7006	40.12	09 18 134 9422	09.25	09 18 506 6901	09.06
09 18 000 9905	09.23	09 18 020 7001 900	40.11	09 18 040 7007	40.13	09 18 134 9622	09.25	09 18 506 6902	09.08
09 18 000 9905	22.30	09 18 020 7004	40.11	09 18 040 7008	40.13			09 18 506 6903	09.06
09 18 000 9905	22.31	09 18 020 7005	40.12	09 18 040 7010	40.13	09 18 140 9422	09.25	09 18 506 6904	09.08
09 18 000 9905 58U	09.23	09 18 020 7006	40.12	09 18 040 7011	40.13	09 18 140 9622	09.25	09 18 506 6906	09.18
09 18 000 9906	09.16	09 18 020 7007	40.13					09 18 506 6907	09.18
09 18 000 9906	09.20	09 18 020 7008	40.13	09 18 050 7001	40.11	09 18 150 9422	09.25	09 18 506 6911	09.06
09 18 000 9906	22.32	09 18 020 7010	40.13	09 18 050 7001 900	40.11	09 18 150 9622	09.25	09 18 506 6912	09.08
		09 18 020 7011	40.13	09 18 050 7004	40.11			09 18 506 6913	09.06
09 18 006 7001	40.11			09 18 050 7005	40.12	09 18 160 9422	09.25	09 18 506 6914	09.08
09 18 006 7001 900	40.11	09 18 024 7001	40.11	09 18 050 7006	40.12	09 18 160 9622	09.25	09 18 506 6916	09.18
09 18 006 7004	40.11	09 18 024 7001 900	40.11	09 18 050 7007	40.13			09 18 506 6917	09.18
09 18 006 7005	40.12	09 18 024 7004	40.11	09 18 050 7008	40.13	09 18 164 9422	09.25	09 18 506 6921	09.06
		09 18 024 7005	40.12	09 18 050 7010	40.13	09 18 164 9622	09.25	09 18 506 6922	09.08
09 18 009 7001	40.11			09 18 050 7011	40.13			09 18 506 6923	09.06
09 18 009 7001 900	40.11	09 18 025 7001	40.11			09 18 500 9902	09.16	09 18 506 6924	09.08
09 18 009 7004	40.11	09 18 025 7001 900	40.11	09 18 060 7001	40.11	09 18 500 9902	09.20	09 18 506 6926	09.18
09 18 009 7005	40.12	09 18 025 7004	40.11	09 18 060 7001 900	40.11	09 18 500 9902	22.32	09 18 506 6927	09.18
09 18 009 7007	40.13	09 18 025 7005	40.12	09 18 060 7004	40.11			09 18 506 6953	09.12
09 18 009 7008	40.13	09 18 025 7005	40.12	09 18 060 7005	40.12	09 18 506 5004	09.10	09 18 506 6963	09.12
09 18 009 7010	40.13	09 18 025 7007	40.13	09 18 060 7006	40.12	09 18 506 5014	09.10	09 18 506 6973	09.12
09 18 009 7011	40.13	09 18 025 7008	40.13	09 18 060 7007	40.13	09 18 506 5024	09.10	09 18 506 7004	09.10
		09 18 025 7010	40.13	09 18 060 7008	40.13	09 18 506 5322	09.15	09 18 506 7014	09.10
		09 18 025 7011	40.13	09 18 060 7010	40.13	09 18 506 5323	09.14	09 18 506 7024	09.10
09 18 010 7001	40.11			09 18 060 7011	40.13	09 18 506 5324	09.15	09 18 506 7322	09.15
09 18 010 7001 900	40.11	09 18 026 7001	40.11			09 18 506 5329	20.19	09 18 506 7323	09.14
09 18 010 7004	40.11	09 18 026 7001 900	40.11	09 18 064 7001	40.11	09 18 506 5803	09.22	09 18 506 7324	09.15
09 18 010 7005	40.12	09 18 026 7004	40.11	09 18 064 7001 900	40.11	09 18 506 5803 58U	09.22	09 18 506 7329	20.19
09 18 010 7006	40.12	09 18 026 7005	40.12	09 18 064 7004	40.11	09 18 506 5804	09.22	09 18 506 7803	09.22
09 18 010 7007	40.13	09 18 026 7006	40.12	09 18 064 7005	40.12	09 18 506 5813	09.22	09 18 506 7803 58U	09.22
09 18 010 7008	40.13	09 18 026 7007	40.13	09 18 064 7006	40.12	09 18 506 5813 58U	09.22	09 18 506 7804	09.22
09 18 010 7010	40.13	09 18 026 7008	40.13						
09 18 010 7011	40.13								

List of part numbers



Part No.	Page	Part No.	Page	Part No.	Page	Part No.	Page	Part No.	Page
09 18 506 7813	09.22	09 18 510 6024	09.10	09 18 510 9002	09.23	09 18 514 6922	09.08	09 18 516 5912	09.08
09 18 506 7813 58U	09.22	09 18 510 6322	09.15	09 18 510 9002 58U	09.23	09 18 514 6923	09.06	09 18 516 5913	09.06
09 18 506 7814	09.22	09 18 510 6323	09.14			09 18 514 6924	09.08	09 18 516 5914	09.08
09 18 506 7901	09.06	09 18 510 6324	09.15			09 18 514 6926	09.18	09 18 516 5916	09.18
09 18 506 7902	09.08	09 18 510 6329	20.19	09 18 514 5004	09.10	09 18 514 6927	09.18	09 18 516 5917	09.18
09 18 506 7903	09.06	09 18 510 6803	09.22	09 18 514 5014	09.10	09 18 514 6953	09.12	09 18 516 5919	20.16
09 18 506 7904	09.08	09 18 510 6803 58U	09.22	09 18 514 5024	09.10	09 18 514 6963	09.12	09 18 516 5921	09.06
09 18 506 7906	09.18	09 18 510 6804	09.22	09 18 514 5322	09.15	09 18 514 6973	09.12	09 18 516 5922	09.08
09 18 506 7907	09.18	09 18 510 6813	09.22	09 18 514 5323	09.14	09 18 514 7004	09.10	09 18 516 5923	09.06
09 18 506 7911	09.06	09 18 510 6813 58U	09.22	09 18 514 5324	09.15	09 18 514 7014	09.10	09 18 516 5924	09.08
09 18 506 7912	09.08	09 18 510 6814	09.22	09 18 514 5329	20.19	09 18 514 7024	09.10	09 18 516 5926	09.18
09 18 506 7913	09.06	09 18 510 6901	09.06	09 18 514 5803	09.22	09 18 514 7322	09.15	09 18 516 5927	09.18
09 18 506 7914	09.08	09 18 510 6902	09.08	09 18 514 5803 58U	09.22	09 18 514 7323	09.14	09 18 516 5929	20.16
09 18 506 7916	09.18	09 18 510 6903	09.06	09 18 514 5804	09.22	09 18 514 7324	09.15	09 18 516 5953	09.12
09 18 506 7917	09.18	09 18 510 6904	09.08	09 18 514 5813	09.22	09 18 514 7329	20.19	09 18 516 5963	09.12
09 18 506 7921	09.06	09 18 510 6906	09.18	09 18 514 5813 58U	09.22	09 18 514 7803	09.22	09 18 516 5973	09.12
09 18 506 7922	09.08	09 18 510 6907	09.18	09 18 514 5814	09.22	09 18 514 7803 58U	09.22	09 18 516 6004	09.10
09 18 506 7923	09.06	09 18 510 6911	09.06	09 18 514 5901	09.06	09 18 514 7804	09.22	09 18 516 6014	09.10
09 18 506 7924	09.08	09 18 510 6912	09.08	09 18 514 5902	09.08	09 18 514 7813	09.22	09 18 516 6024	09.10
09 18 506 7926	09.18	09 18 510 6913	09.06	09 18 514 5903	09.06	09 18 514 7813 58U	09.22	09 18 516 6322	09.15
09 18 506 7927	09.18	09 18 510 6914	09.08	09 18 514 5904	09.08	09 18 514 7814	09.22	09 18 516 6323	09.14
09 18 506 7953	09.12	09 18 510 6916	09.18	09 18 514 5906	09.18	09 18 514 7901	09.06	09 18 516 6324	09.15
09 18 506 7963	09.12	09 18 510 6917	09.18	09 18 514 5907	09.18	09 18 514 7902	09.08	09 18 516 6329	20.19
09 18 506 7973	09.12	09 18 510 6921	09.06	09 18 514 5909	20.16	09 18 514 7903	09.06	09 18 516 6803	09.22
09 18 506 9002	09.23	09 18 510 6922	09.08	09 18 514 5911	09.06	09 18 514 7904	09.08	09 18 516 6803 58U	09.22
09 18 506 9002 58U	09.23	09 18 510 6923	09.06	09 18 514 5912	09.08	09 18 514 7906	09.18	09 18 516 6804	09.22
		09 18 510 6924	09.08	09 18 514 5913	09.06	09 18 514 7907	09.18	09 18 516 6813	09.22
		09 18 510 6926	09.18	09 18 514 5914	09.08	09 18 514 7911	09.06	09 18 516 6813 58U	09.22
09 18 510 5004	09.10	09 18 510 6927	09.18	09 18 514 5916	09.18	09 18 514 7912	09.08	09 18 516 6814	09.22
09 18 510 5014	09.10	09 18 510 6927	09.18	09 18 514 5917	09.18	09 18 514 7913	09.06	09 18 516 6901	09.06
09 18 510 5024	09.10	09 18 510 6953	09.12	09 18 514 5919	20.16	09 18 514 7914	09.08	09 18 516 6902	09.08
09 18 510 5322	09.15	09 18 510 6963	09.12	09 18 514 5921	09.06	09 18 514 7916	09.18	09 18 516 6903	09.06
09 18 510 5323	09.14	09 18 510 6973	09.12	09 18 514 5922	09.08	09 18 514 7917	09.18	09 18 516 6904	09.08
09 18 510 5324	09.15	09 18 510 7004	09.10	09 18 514 5923	09.06	09 18 514 7921	09.06	09 18 516 6906	09.18
09 18 510 5329	20.19	09 18 510 7014	09.10	09 18 514 5924	09.08	09 18 514 7922	09.08	09 18 516 6906	09.18
09 18 510 5803	09.22	09 18 510 7024	09.10	09 18 514 5926	09.18	09 18 514 7923	09.06	09 18 516 6907	09.18
09 18 510 5803 58U	09.22	09 18 510 7322	09.15	09 18 514 5927	09.18	09 18 514 7924	09.08	09 18 516 6911	09.06
09 18 510 5804	09.22	09 18 510 7323	09.14	09 18 514 5929	20.16	09 18 514 7926	09.18	09 18 516 6912	09.08
09 18 510 5813	09.22	09 18 510 7324	09.15	09 18 514 5953	09.12	09 18 514 7927	09.18	09 18 516 6913	09.06
09 18 510 5813 58U	09.22	09 18 510 7329	20.19	09 18 514 5963	09.12	09 18 514 7927	09.18	09 18 516 6914	09.08
09 18 510 5814	09.22	09 18 510 7803	09.22	09 18 514 5973	09.12	09 18 514 7953	09.12	09 18 516 6916	09.18
09 18 510 5901	09.06	09 18 510 7803 58U	09.22	09 18 514 5977	09.12	09 18 514 7963	09.12	09 18 516 6917	09.18
09 18 510 5902	09.08	09 18 510 7804	09.22	09 18 514 6004	09.10	09 18 514 7973	09.12	09 18 516 6921	09.06
09 18 510 5903	09.06	09 18 510 7813	09.22	09 18 514 6014	09.10	09 18 514 9002	09.23	09 18 516 6922	09.08
09 18 510 5904	09.08	09 18 510 7813 58U	09.22	09 18 514 6024	09.10	09 18 514 9002 58U	09.23	09 18 516 6923	09.06
09 18 510 5906	09.18	09 18 510 7814	09.22	09 18 514 6322	09.15			09 18 516 6924	09.08
09 18 510 5907	09.18	09 18 510 7814	09.22	09 18 514 6323	09.14			09 18 516 6926	09.18
09 18 510 5909	20.16	09 18 510 7901	09.06	09 18 514 6324	09.15	09 18 516 5004	09.10	09 18 516 6927	09.18
09 18 510 5911	09.06	09 18 510 7902	09.08	09 18 514 6329	20.19	09 18 516 5014	09.10	09 18 516 6927	09.18
09 18 510 5912	09.08	09 18 510 7903	09.06	09 18 514 6803	09.22	09 18 516 5024	09.10	09 18 516 6953	09.12
09 18 510 5913	09.06	09 18 510 7904	09.08	09 18 514 6803 58U	09.22	09 18 516 5322	09.15	09 18 516 6963	09.12
09 18 510 5914	09.08	09 18 510 7906	09.18	09 18 514 6804	09.22	09 18 516 5323	09.14	09 18 516 6973	09.12
09 18 510 5916	09.18	09 18 510 7907	09.18	09 18 514 6813	09.22	09 18 516 5324	09.15	09 18 516 7004	09.10
09 18 510 5917	09.18	09 18 510 7911	09.06	09 18 514 6813 58U	09.22	09 18 516 5329	20.19	09 18 516 7014	09.10
09 18 510 5919	20.16	09 18 510 7912	09.08	09 18 514 6814	09.22	09 18 516 5803	09.22	09 18 516 7024	09.10
09 18 510 5921	09.06	09 18 510 7913	09.06	09 18 514 6901	09.06	09 18 516 5803 58U	09.22	09 18 516 7322	09.15
09 18 510 5922	09.08	09 18 510 7914	09.08	09 18 514 6902	09.08	09 18 516 5804	09.22	09 18 516 7323	09.14
09 18 510 5923	09.06	09 18 510 7916	09.18	09 18 514 6903	09.06	09 18 516 5813	09.22	09 18 516 7324	09.15
09 18 510 5924	09.08	09 18 510 7917	09.18	09 18 514 6904	09.08	09 18 516 5813 58U	09.22	09 18 516 7329	20.19
09 18 510 5926	09.18	09 18 510 7921	09.06	09 18 514 6906	09.18	09 18 516 5814	09.22	09 18 516 7803	09.22
09 18 510 5927	09.18	09 18 510 7922	09.08	09 18 514 6907	09.18	09 18 516 5901	09.06	09 18 516 7803 58U	09.22
09 18 510 5929	20.16	09 18 510 7923	09.06	09 18 514 6911	09.06	09 18 516 5902	09.08	09 18 516 7804	09.22
09 18 510 5953	09.12	09 18 510 7924	09.08	09 18 514 6912	09.08	09 18 516 5903	09.06	09 18 516 7813	09.22
09 18 510 5963	09.12	09 18 510 7926	09.18	09 18 514 6913	09.06	09 18 516 5904	09.08	09 18 516 7813 58U	09.22
09 18 510 5973	09.12	09 18 510 7927	09.18	09 18 514 6914	09.08	09 18 516 5906	09.18	09 18 516 7814	09.22
09 18 510 6004	09.10	09 18 510 7927	09.18	09 18 514 6916	09.18	09 18 516 5907	09.18	09 18 516 7901	09.06
09 18 510 6014	09.10	09 18 510 7953	09.12	09 18 514 6917	09.18	09 18 516 5909	20.16	09 18 516 7902	09.08
		09 18 510 7963	09.12	09 18 514 6917	09.18	09 18 516 5911	09.06	09 18 516 7903	09.06
		09 18 510 7973	09.12	09 18 514 6921	09.06				

Part No.

List of part numbers



Part No.	Page	Part No.	Page	Part No.	Page	Part No.	Page	Part No.	Page
09 18 516 7904	09.08	09 18 520 6803 58U	09.22	09 18 524 5803	09.22	09 18 524 7921	09.06	09 18 526 6907	09.18
09 18 516 7906	09.18	09 18 520 6804	09.22	09 18 524 5813	09.22	09 18 524 7922	09.08	09 18 526 6911	09.06
09 18 516 7907	09.18	09 18 520 6813	09.22	09 18 524 5901	09.06	09 18 524 7923	09.06	09 18 526 6912	09.08
09 18 516 7911	09.06	09 18 520 6813 58U	09.22	09 18 524 5902	09.08	09 18 524 7924	09.08	09 18 526 6913	09.06
09 18 516 7912	09.08	09 18 520 6814	09.22	09 18 524 5903	09.06	09 18 524 7926	09.18	09 18 526 6914	09.08
09 18 516 7913	09.06	09 18 520 6901	09.06	09 18 524 5904	09.08	09 18 524 7927	09.18	09 18 526 6916	09.18
09 18 516 7914	09.08	09 18 520 6902	09.08	09 18 524 5906	09.18	09 18 524 7953	09.12	09 18 526 6917	09.18
09 18 516 7916	09.18	09 18 520 6903	09.06	09 18 524 5907	09.18	09 18 524 7963	09.12	09 18 526 6921	09.06
09 18 516 7917	09.18	09 18 520 6904	09.08	09 18 524 5911	09.06	09 18 524 7973	09.12	09 18 526 6922	09.08
09 18 516 7921	09.06	09 18 520 6906	09.18	09 18 524 5912	09.08	09 18 524 9002	09.23	09 18 526 6923	09.06
09 18 516 7922	09.08	09 18 520 6907	09.18	09 18 524 5913	09.06			09 18 526 6924	09.08
09 18 516 7923	09.06	09 18 520 6911	09.06	09 18 524 5914	09.08			09 18 526 6926	09.18
09 18 516 7924	09.08	09 18 520 6912	09.08	09 18 524 5916	09.18	09 18 526 5004	09.10	09 18 526 6927	09.18
09 18 516 7926	09.18	09 18 520 6913	09.06	09 18 524 5917	09.18	09 18 526 5014	09.10	09 18 526 6953	09.12
09 18 516 7927	09.18	09 18 520 6914	09.08	09 18 524 5921	09.06	09 18 526 5024	09.10	09 18 526 6963	09.12
09 18 516 7953	09.12	09 18 520 6916	09.18	09 18 524 5922	09.08	09 18 526 5322	09.15	09 18 526 6973	09.12
09 18 516 7963	09.12	09 18 520 6917	09.18	09 18 524 5923	09.06	09 18 526 5323	09.14	09 18 526 6973	09.12
09 18 516 7973	09.12	09 18 520 6921	09.06	09 18 524 5924	09.08	09 18 526 5324	09.15	09 18 526 7004	09.10
09 18 516 9002	09.23	09 18 520 6922	09.08	09 18 524 5926	09.18	09 18 526 5329	20.19	09 18 526 7014	09.10
09 18 516 9002 58U	09.23	09 18 520 6923	09.06	09 18 524 5927	09.18	09 18 526 5803	09.22	09 18 526 7024	09.10
		09 18 520 6924	09.08	09 18 524 5927	09.18	09 18 526 5803 58U	09.22	09 18 526 7024	09.10
		09 18 520 6926	09.18	09 18 524 5953	09.12	09 18 526 5804	09.22	09 18 526 7322	09.15
		09 18 520 6927	09.18	09 18 524 5963	09.12	09 18 526 5813	09.22	09 18 526 7323	09.14
09 18 520 5004	09.10	09 18 520 6927	09.18	09 18 524 5963	09.12	09 18 526 5813 58U	09.22	09 18 526 7324	09.15
09 18 520 5014	09.10	09 18 520 6953	09.12	09 18 524 5973	09.12	09 18 526 5814	09.22	09 18 526 7329	20.19
09 18 520 5024	09.10	09 18 520 6963	09.12	09 18 524 6004	09.10	09 18 526 5901	09.06	09 18 526 7803	09.22
09 18 520 5322	09.15	09 18 520 6973	09.12	09 18 524 6014	09.10	09 18 526 5902	09.08	09 18 526 7803 58U	09.22
09 18 520 5323	09.14	09 18 520 7004	09.10	09 18 524 6024	09.10	09 18 526 5903	09.06	09 18 526 7804	09.22
09 18 520 5324	09.15	09 18 520 7014	09.10	09 18 524 6803	09.22	09 18 526 5904	09.08	09 18 526 7813	09.22
09 18 520 5329	20.19	09 18 520 7024	09.10	09 18 524 6813	09.22	09 18 526 5906	09.18	09 18 526 7813 58U	09.22
09 18 520 5803	09.22	09 18 520 7322	09.15	09 18 524 6901	09.06	09 18 526 5907	09.18	09 18 526 7814	09.22
09 18 520 5803 58U	09.22	09 18 520 7323	09.14	09 18 524 6902	09.08	09 18 526 5909	20.16	09 18 526 7901	09.06
09 18 520 5804	09.22	09 18 520 7324	09.15	09 18 524 6903	09.06	09 18 526 5911	09.06	09 18 526 7902	09.08
09 18 520 5813	09.22	09 18 520 7329	20.19	09 18 524 6904	09.08	09 18 526 5912	09.08	09 18 526 7903	09.06
09 18 520 5813 58U	09.22	09 18 520 7803	09.22	09 18 524 6906	09.18	09 18 526 5913	09.06	09 18 526 7904	09.08
09 18 520 5814	09.22	09 18 520 7803 58U	09.22	09 18 524 6907	09.18	09 18 526 5914	09.08	09 18 526 7906	09.18
09 18 520 5901	09.06	09 18 520 7804	09.22	09 18 524 6911	09.06	09 18 526 5916	09.18	09 18 526 7907	09.18
09 18 520 5902	09.08	09 18 520 7813	09.22	09 18 524 6912	09.08	09 18 526 5917	09.18	09 18 526 7911	09.06
09 18 520 5903	09.06	09 18 520 7813 58U	09.22	09 18 524 6913	09.06	09 18 526 5919	20.16	09 18 526 7912	09.08
09 18 520 5904	09.08	09 18 520 7814	09.22	09 18 524 6914	09.08	09 18 526 5921	09.06	09 18 526 7913	09.06
09 18 520 5906	09.18	09 18 520 7901	09.06	09 18 524 6916	09.18	09 18 526 5922	09.08	09 18 526 7914	09.08
09 18 520 5907	09.18	09 18 520 7902	09.08	09 18 524 6917	09.18	09 18 526 5923	09.06	09 18 526 7916	09.18
09 18 520 5909	20.16	09 18 520 7903	09.06	09 18 524 6921	09.06	09 18 526 5924	09.08	09 18 526 7917	09.18
09 18 520 5911	09.06	09 18 520 7904	09.08	09 18 524 6922	09.08	09 18 526 5926	09.18	09 18 526 7921	09.06
09 18 520 5912	09.08	09 18 520 7906	09.18	09 18 524 6923	09.06	09 18 526 5929	20.16	09 18 526 7922	09.08
09 18 520 5913	09.06	09 18 520 7907	09.18	09 18 524 6924	09.08	09 18 526 5953	09.12	09 18 526 7923	09.06
09 18 520 5914	09.08	09 18 520 7911	09.06	09 18 524 6926	09.18	09 18 526 5963	09.12	09 18 526 7924	09.08
09 18 520 5916	09.18	09 18 520 7912	09.08	09 18 524 6927	09.18	09 18 526 5973	09.12	09 18 526 7926	09.18
09 18 520 5917	09.18	09 18 520 7913	09.06	09 18 524 6953	09.12	09 18 526 6004	09.10	09 18 526 7927	09.18
09 18 520 5919	20.16	09 18 520 7914	09.08	09 18 524 6963	09.12	09 18 526 6014	09.10	09 18 526 7953	09.12
09 18 520 5921	09.06	09 18 520 7916	09.18	09 18 524 6973	09.12	09 18 526 6024	09.10	09 18 526 7963	09.12
09 18 520 5922	09.08	09 18 520 7917	09.18	09 18 524 7004	09.10	09 18 526 6322	09.15	09 18 526 7973	09.12
09 18 520 5923	09.06	09 18 520 7921	09.06	09 18 524 7014	09.10	09 18 526 6324	09.15	09 18 526 9002	09.23
09 18 520 5924	09.08	09 18 520 7922	09.08	09 18 524 7024	09.10	09 18 526 6329	20.19	09 18 526 9002 58U	09.23
09 18 520 5926	09.18	09 18 520 7923	09.06	09 18 524 7803	09.22	09 18 526 6803	09.22		
09 18 520 5927	09.18	09 18 520 7924	09.08	09 18 524 7813	09.22	09 18 526 6803 58U	09.22		
09 18 520 5929	20.16	09 18 520 7926	09.18	09 18 524 7901	09.06	09 18 526 6804	09.22	09 18 530 5004	09.10
09 18 520 5953	09.12	09 18 520 7927	09.18	09 18 524 7902	09.08	09 18 526 6813	09.22	09 18 530 5014	09.10
09 18 520 5963	09.12	09 18 520 7953	09.12	09 18 524 7903	09.06	09 18 526 6813 58U	09.22	09 18 530 5024	09.10
09 18 520 5973	09.12	09 18 520 7963	09.12	09 18 524 7904	09.08	09 18 526 6814	09.22	09 18 530 5322	09.15
09 18 520 6004	09.10	09 18 520 7973	09.12	09 18 524 7906	09.18	09 18 526 6901	09.06	09 18 530 5323	09.14
09 18 520 6014	09.10	09 18 520 9002	09.23	09 18 524 7907	09.18	09 18 526 6902	09.08	09 18 530 5324	09.15
09 18 520 6024	09.10	09 18 520 9002 58U	09.23	09 18 524 7911	09.06	09 18 526 6903	09.06	09 18 530 5803	09.22
09 18 520 6322	09.15			09 18 524 7912	09.08	09 18 526 6904	09.08	09 18 530 5803 58U	09.22
09 18 520 6323	09.14			09 18 524 7913	09.06	09 18 526 6906	09.18	09 18 530 5804	09.22
09 18 520 6324	09.15	09 18 524 5004	09.10	09 18 524 7914	09.08			09 18 530 5813	09.22
09 18 520 6329	20.19	09 18 524 5014	09.10	09 18 524 7916	09.18			09 18 530 5813 58U	09.22
09 18 520 6803	09.22	09 18 524 5024	09.10	09 18 524 7917	09.18			09 18 530 5814	09.22
								09 18 530 5901	09.06

List of part numbers



Part No.	Page	Part No.	Page	Part No.	Page	Part No.	Page	Part No.	Page
09 18 530 5902	09.08	09 18 530 7902	09.08	09 18 534 6329	20.19	09 18 540 5004	09.10	09 18 540 6926	09.18
09 18 530 5903	09.06	09 18 530 7903	09.06	09 18 534 6803	09.22	09 18 540 5014	09.10	09 18 540 6927	09.18
09 18 530 5904	09.08	09 18 530 7904	09.08	09 18 534 6803 58U	09.22	09 18 540 5024	09.10	09 18 540 6953	09.12
09 18 530 5906	09.18	09 18 530 7906	09.18	09 18 534 6804	09.22	09 18 540 5322	09.15	09 18 540 6963	09.12
09 18 530 5907	09.18	09 18 530 7907	09.18	09 18 534 6813	09.22	09 18 540 5323	09.14	09 18 540 6973	09.12
09 18 530 5911	09.06	09 18 530 7911	09.06	09 18 534 6813 58U	09.22	09 18 540 5324	09.15	09 18 540 7004	09.10
09 18 530 5912	09.08	09 18 530 7912	09.08	09 18 534 6814	09.22	09 18 540 5329	20.19	09 18 540 7014	09.10
09 18 530 5913	09.06	09 18 530 7913	09.06	09 18 534 6901	09.06	09 18 540 5803	09.22	09 18 540 7024	09.10
09 18 530 5914	09.08	09 18 530 7914	09.08	09 18 534 6902	09.08	09 18 540 5803 58U	09.22	09 18 540 7322	09.15
09 18 530 5916	09.18	09 18 530 7916	09.18	09 18 534 6903	09.06	09 18 540 5804	09.22	09 18 540 7323	09.14
09 18 530 5917	09.18	09 18 530 7917	09.18	09 18 534 6904	09.08	09 18 540 5813	09.22	09 18 540 7324	09.15
09 18 530 5921	09.06	09 18 530 7921	09.06	09 18 534 6904	09.08	09 18 540 5813 58U	09.22	09 18 540 7329	20.19
09 18 530 5922	09.08	09 18 530 7922	09.08	09 18 534 6906	09.18	09 18 540 5814	09.22	09 18 540 7803	09.22
09 18 530 5923	09.06	09 18 530 7923	09.06	09 18 534 6907	09.18	09 18 540 5901	09.06	09 18 540 7803 58U	09.22
09 18 530 5924	09.08	09 18 530 7924	09.08	09 18 534 6911	09.06	09 18 540 5902	09.08	09 18 540 7804	09.22
09 18 530 5926	09.18	09 18 530 7926	09.18	09 18 534 6912	09.08	09 18 540 5903	09.06	09 18 540 7813	09.22
09 18 530 5927	09.18	09 18 530 7927	09.18	09 18 534 6913	09.06	09 18 540 5904	09.08	09 18 540 7813 58U	09.22
09 18 530 5953	09.12	09 18 530 7953	09.12	09 18 534 6914	09.08	09 18 540 5906	09.18	09 18 540 7814	09.22
09 18 530 5963	09.12	09 18 530 7963	09.12	09 18 534 6916	09.18	09 18 540 5907	09.18	09 18 540 7901	09.06
09 18 530 5973	09.12	09 18 530 7973	09.12	09 18 534 6917	09.18	09 18 540 5909	20.16	09 18 540 7902	09.08
09 18 530 6004	09.10	09 18 530 9002	09.23	09 18 534 6921	09.06	09 18 540 5911	09.06	09 18 540 7903	09.06
09 18 530 6014	09.10	09 18 530 9002 58U	09.23	09 18 534 6922	09.08	09 18 540 5912	09.08	09 18 540 7904	09.08
09 18 530 6024	09.10			09 18 534 6923	09.06	09 18 540 5913	09.06	09 18 540 7906	09.18
09 18 530 6322	09.15			09 18 534 6924	09.08	09 18 540 5914	09.08	09 18 540 7907	09.18
09 18 530 6323	09.14	09 18 534 5004	09.10	09 18 534 6926	09.18	09 18 540 5916	09.18	09 18 540 7911	09.06
09 18 530 6324	09.15	09 18 534 5014	09.10	09 18 534 6927	09.18	09 18 540 5917	09.18	09 18 540 7912	09.08
09 18 530 6803	09.22	09 18 534 5024	09.10	09 18 534 6953	09.12	09 18 540 5919	20.16	09 18 540 7913	09.06
09 18 530 6803 58U	09.22	09 18 534 5322	09.15	09 18 534 6963	09.12	09 18 540 5921	09.06	09 18 540 7914	09.08
09 18 530 6804	09.22	09 18 534 5323	09.14	09 18 534 6973	09.12	09 18 540 5922	09.08	09 18 540 7916	09.18
09 18 530 6813	09.22	09 18 534 5324	09.15	09 18 534 6973	09.12	09 18 540 5923	09.06	09 18 540 7917	09.18
09 18 530 6813 58U	09.22	09 18 534 5329	20.19	09 18 534 7004	09.10	09 18 540 5924	09.08	09 18 540 7921	09.06
09 18 530 6814	09.22	09 18 534 5803	09.22	09 18 534 7014	09.10	09 18 540 5926	09.18	09 18 540 7922	09.08
09 18 530 6901	09.06	09 18 534 5803 58U	09.22	09 18 534 7024	09.10	09 18 540 5927	09.18	09 18 540 7923	09.06
09 18 530 6902	09.08	09 18 534 5804	09.22	09 18 534 7322	09.15	09 18 540 5927	09.18	09 18 540 7924	09.08
09 18 530 6903	09.06	09 18 534 5813	09.22	09 18 534 7323	09.14	09 18 540 5929	20.16	09 18 540 7926	09.18
09 18 530 6904	09.08	09 18 534 5813 58U	09.22	09 18 534 7324	09.15	09 18 540 5953	09.12	09 18 540 7927	09.18
09 18 530 6906	09.18	09 18 534 5814	09.22	09 18 534 7329	20.19	09 18 540 5963	09.12	09 18 540 7929	09.18
09 18 530 6907	09.18	09 18 534 5901	09.06	09 18 534 7803	09.22	09 18 540 5973	09.12	09 18 540 7953	09.12
09 18 530 6911	09.06	09 18 534 5902	09.08	09 18 534 7803 58U	09.22	09 18 540 6004	09.10	09 18 540 7963	09.12
09 18 530 6912	09.08	09 18 534 5903	09.06	09 18 534 7804	09.22	09 18 540 6014	09.10	09 18 540 7973	09.12
09 18 530 6913	09.06	09 18 534 5904	09.08	09 18 534 7813	09.22	09 18 540 6024	09.10	09 18 540 9002	09.23
09 18 530 6914	09.08	09 18 534 5906	09.18	09 18 534 7813 58U	09.22	09 18 540 6322	09.15	09 18 540 9002 58U	09.23
09 18 530 6916	09.18	09 18 534 5907	09.18	09 18 534 7814	09.22	09 18 540 6323	09.14		
09 18 530 6917	09.18	09 18 534 5909	20.16	09 18 534 7901	09.06	09 18 540 6324	09.15	09 18 550 5004	09.10
09 18 530 6921	09.06	09 18 534 5911	09.06	09 18 534 7902	09.08	09 18 540 6329	20.19	09 18 550 5014	09.10
09 18 530 6922	09.08	09 18 534 5912	09.08	09 18 534 7903	09.06	09 18 540 6803	09.22	09 18 550 5024	09.10
09 18 530 6923	09.06	09 18 534 5913	09.06	09 18 534 7904	09.08	09 18 540 6803 58U	09.22	09 18 550 5322	09.15
09 18 530 6924	09.08	09 18 534 5914	09.08	09 18 534 7906	09.18	09 18 540 6804	09.22	09 18 550 5323	09.14
09 18 530 6926	09.18	09 18 534 5916	09.18	09 18 534 7907	09.18	09 18 540 6813	09.22	09 18 550 5324	09.15
09 18 530 6927	09.18	09 18 534 5917	09.18	09 18 534 7911	09.06	09 18 540 6813 58U	09.22	09 18 550 5329	20.19
09 18 530 6953	09.12	09 18 534 5919	20.16	09 18 534 7912	09.08	09 18 540 6814	09.22	09 18 550 5803	09.22
09 18 530 6963	09.12	09 18 534 5921	09.06	09 18 534 7913	09.06	09 18 540 6901	09.06	09 18 550 5804	09.22
09 18 530 6973	09.12	09 18 534 5922	09.08	09 18 534 7914	09.08	09 18 540 6902	09.08	09 18 550 5813	09.22
09 18 530 7004	09.10	09 18 534 5923	09.06	09 18 534 7916	09.18	09 18 540 6903	09.06	09 18 550 5814	09.22
09 18 530 7014	09.10	09 18 534 5924	09.08	09 18 534 7917	09.18	09 18 540 6904	09.08	09 18 550 5901	09.06
09 18 530 7024	09.10	09 18 534 5926	09.18	09 18 534 7919	09.18	09 18 540 6906	09.18	09 18 550 5902	09.08
09 18 530 7322	09.15	09 18 534 5927	09.18	09 18 534 7921	09.06	09 18 540 6907	09.18	09 18 550 5903	09.06
09 18 530 7323	09.14	09 18 534 5929	20.16	09 18 534 7922	09.08	09 18 540 6911	09.06	09 18 550 5904	09.08
09 18 530 7324	09.15	09 18 534 5953	09.12	09 18 534 7923	09.06	09 18 540 6912	09.08	09 18 550 5906	09.18
09 18 530 7803	09.22	09 18 534 5963	09.12	09 18 534 7924	09.08	09 18 540 6913	09.06	09 18 550 5907	09.18
09 18 530 7803 58U	09.22	09 18 534 5973	09.12	09 18 534 7926	09.18	09 18 540 6914	09.08	09 18 550 5909	20.16
09 18 530 7804	09.22	09 18 534 6004	09.10	09 18 534 7927	09.18	09 18 540 6916	09.18	09 18 550 5911	09.06
09 18 530 7813	09.22	09 18 534 6014	09.10	09 18 534 7953	09.12	09 18 540 6917	09.18	09 18 550 5912	09.08
09 18 530 7813 58U	09.22	09 18 534 6024	09.10	09 18 534 7963	09.12	09 18 540 6921	09.06	09 18 550 5913	09.06
09 18 530 7814	09.22	09 18 534 6322	09.15	09 18 534 7973	09.12	09 18 540 6922	09.08	09 18 550 5914	09.08
09 18 530 7901	09.06	09 18 534 6323	09.14	09 18 534 9002	09.23	09 18 540 6923	09.06	09 18 550 5916	09.18
		09 18 534 6324	09.15	09 18 534 9002 58U	09.23	09 18 540 6924	09.08	09 18 550 5917	09.18

Part No.

List of part numbers



Part No.	Page	Part No.	Page	Part No.	Page	Part No.	Page	Part No.	Page
09 18 550 5919	20.16	09 18 550 7921	09.06	09 18 560 6914	09.08	09 18 564 5913	09.06	09 18 564 7913	09.06
09 18 550 5921	09.06	09 18 550 7922	09.08	09 18 560 6916	09.18	09 18 564 5914	09.08	09 18 564 7914	09.08
09 18 550 5922	09.08	09 18 550 7923	09.06	09 18 560 6917	09.18	09 18 564 5916	09.18	09 18 564 7916	09.18
09 18 550 5923	09.06	09 18 550 7924	09.08	09 18 560 6921	09.06	09 18 564 5917	09.18	09 18 564 7917	09.18
09 18 550 5924	09.08	09 18 550 7926	09.18	09 18 560 6922	09.08	09 18 564 5919	20.16	09 18 564 7921	09.06
09 18 550 5926	09.18	09 18 550 7927	09.18	09 18 560 6923	09.06	09 18 564 5921	09.06	09 18 564 7922	09.08
09 18 550 5927	09.18	09 18 550 7953	09.12	09 18 560 6924	09.08	09 18 564 5922	09.08	09 18 564 7923	09.06
09 18 550 5929	20.16	09 18 550 7963	09.12	09 18 560 6926	09.18	09 18 564 5923	09.06	09 18 564 7924	09.08
09 18 550 5953	09.12	09 18 550 7973	09.12	09 18 560 6927	09.18	09 18 564 5924	09.08	09 18 564 7926	09.18
09 18 550 5963	09.12	09 18 550 9002	09.23	09 18 560 6953	09.12	09 18 564 5926	09.18	09 18 564 7927	09.18
09 18 550 5973	09.12			09 18 560 6963	09.12	09 18 564 5927	09.18	09 18 564 7953	09.12
09 18 550 6004	09.10	09 18 560 5004	09.10	09 18 560 6973	09.12	09 18 564 5929	20.16	09 18 564 7963	09.12
09 18 550 6014	09.10	09 18 560 5014	09.10	09 18 560 7004	09.10	09 18 564 5953	09.12	09 18 564 7973	09.12
09 18 550 6024	09.10	09 18 560 5024	09.10	09 18 560 7014	09.10	09 18 564 5963	09.12	09 18 564 9002	09.23
09 18 550 6322	09.15	09 18 560 5322	09.15	09 18 560 7024	09.10	09 18 564 5973	09.12		
09 18 550 6323	09.14	09 18 560 5323	09.14	09 18 560 7322	09.15	09 18 564 6004	09.10	09 19 000 9903	22.32
09 18 550 6324	09.15	09 18 560 5324	09.15	09 18 560 7323	09.14	09 18 564 6014	09.10	09 19 000 9904	22.32
09 18 550 6329	20.19	09 18 560 5329	20.19	09 18 560 7324	09.15	09 18 564 6024	09.10		
09 18 550 6803	09.22	09 18 560 5803	09.22	09 18 560 7329	20.19	09 18 564 6322	09.15	09 19 010 9643	09.27
09 18 550 6804	09.22	09 18 560 5804	09.22	09 18 560 7803	09.22	09 18 564 6323	09.14		
09 18 550 6813	09.22	09 18 560 5813	09.22	09 18 560 7804	09.22	09 18 564 6324	09.15	09 19 016 9643	09.27
09 18 550 6814	09.22	09 18 560 5814	09.22	09 18 560 7813	09.22	09 18 564 6329	20.19		
09 18 550 6901	09.06	09 18 560 5901	09.06	09 18 560 7814	09.22	09 18 564 6803	09.22	09 19 020 9643	09.27
09 18 550 6902	09.08	09 18 560 5902	09.08	09 18 560 7901	09.06	09 18 564 6804	09.22		
09 18 550 6903	09.06	09 18 560 5903	09.06	09 18 560 7902	09.08	09 18 564 6813	09.22	09 19 026 9643	09.27
09 18 550 6904	09.08	09 18 560 5904	09.08	09 18 560 7903	09.06	09 18 564 6814	09.22		
09 18 550 6906	09.18	09 18 560 5906	09.18	09 18 560 7904	09.08	09 18 564 6901	09.06	09 19 034 9643	09.27
09 18 550 6907	09.18	09 18 560 5907	09.18	09 18 560 7906	09.18	09 18 564 6902	09.08		
09 18 550 6911	09.06	09 18 560 5909	20.16	09 18 560 7907	09.18	09 18 564 6903	09.06	09 19 040 9643	09.27
09 18 550 6912	09.08	09 18 560 5911	09.06	09 18 560 7907	09.18	09 18 564 6904	09.08		
09 18 550 6913	09.06	09 18 560 5912	09.08	09 18 560 7911	09.06	09 18 564 6904	09.08		
09 18 550 6914	09.08	09 18 560 5912	09.08	09 18 560 7912	09.08	09 18 564 6906	09.18	09 19 050 9643	09.27
09 18 550 6916	09.18	09 18 560 5913	09.06	09 18 560 7913	09.06	09 18 564 6907	09.18		
09 18 550 6917	09.18	09 18 560 5914	09.08	09 18 560 7914	09.08	09 18 564 6907	09.18		
09 18 550 6921	09.06	09 18 560 5914	09.08	09 18 560 7916	09.18	09 18 564 6911	09.06		
09 18 550 6922	09.08	09 18 560 5916	09.18	09 18 560 7916	09.18	09 18 564 6912	09.08	09 19 506 5004	22.26
09 18 550 6923	09.06	09 18 560 5916	09.18	09 18 560 7917	09.18	09 18 564 6913	09.06	09 19 506 5014	22.26
09 18 550 6924	09.08	09 18 560 5917	09.18	09 18 560 7917	09.18	09 18 564 6913	09.06	09 19 506 5024	22.26
09 18 550 6926	09.18	09 18 560 5917	09.18	09 18 560 7921	09.06	09 18 564 6914	09.08	09 19 506 5323	22.30
09 18 550 6927	09.18	09 18 560 5919	20.16	09 18 560 7922	09.08	09 18 564 6916	09.18	09 19 506 5323 740	22.30
09 18 550 6953	09.12	09 18 560 5921	09.06	09 18 560 7922	09.08	09 18 564 6917	09.18	09 19 506 5323 741	22.30
09 18 550 6963	09.12	09 18 560 5922	09.08	09 18 560 7923	09.06	09 18 564 6919	09.18	09 19 506 5324	22.31
09 18 550 6973	09.12	09 18 560 5922	09.08	09 18 560 7924	09.08	09 18 564 6921	09.06	09 19 506 5324 740	22.31
09 18 550 7004	09.10	09 18 560 5923	09.06	09 18 560 7924	09.08	09 18 564 6922	09.08	09 19 506 5324 741	22.31
09 18 550 7014	09.10	09 18 560 5923	09.06	09 18 560 7926	09.18	09 18 564 6923	09.06	09 19 506 5903	22.22
09 18 550 7024	09.10	09 18 560 5924	09.08	09 18 560 7927	09.18	09 18 564 6924	09.08	09 19 506 5904	22.24
09 18 550 7322	09.15	09 18 560 5926	09.18	09 18 560 7953	09.12	09 18 564 6926	09.18	09 19 506 5913	22.22
09 18 550 7323	09.14	09 18 560 5927	09.18	09 18 560 7963	09.12	09 18 564 6927	09.18	09 19 506 5914	22.24
09 18 550 7324	09.15	09 18 560 5929	20.16	09 18 560 7973	09.12	09 18 564 6953	09.12	09 19 506 5923	22.22
09 18 550 7329	20.19	09 18 560 5929	20.16	09 18 560 9002	09.23	09 18 564 6963	09.12	09 19 506 5924	22.24
09 18 550 7803	09.22	09 18 560 6004	09.10			09 18 564 6973	09.12	09 19 506 5953	22.28
09 18 550 7804	09.22	09 18 560 6004	09.10	09 18 564 5004	09.10	09 18 564 7004	09.10	09 19 506 5963	22.28
09 18 550 7813	09.22	09 18 560 6014	09.10	09 18 564 5014	09.10	09 18 564 7014	09.10	09 19 506 5973	22.28
09 18 550 7814	09.22	09 18 560 6024	09.10	09 18 564 5024	09.10	09 18 564 7322	09.15	09 19 506 6004	22.26
09 18 550 7901	09.06	09 18 560 6322	09.15	09 18 564 5322	09.15	09 18 564 7323	09.14	09 19 506 6014	22.26
09 18 550 7902	09.08	09 18 560 6323	09.14	09 18 564 5323	09.14	09 18 564 7324	09.15	09 19 506 6024	22.26
09 18 550 7903	09.06	09 18 560 6324	09.15	09 18 564 5324	09.15	09 18 564 7329	20.19	09 19 506 6323	22.30
09 18 550 7904	09.08	09 18 560 6329	20.19	09 18 564 5329	20.19	09 18 564 7803	09.22	09 19 506 6323 740	22.30
09 18 550 7906	09.18	09 18 560 6803	09.22	09 18 564 5803	09.22	09 18 564 7804	09.22	09 19 506 6323 741	22.30
09 18 550 7907	09.18	09 18 560 6804	09.22	09 18 564 5804	09.22	09 18 564 7813	09.22	09 19 506 6324	22.31
09 18 550 7911	09.06	09 18 560 6813	09.22	09 18 564 5813	09.22	09 18 564 7814	09.22	09 19 506 6324 740	22.31
09 18 550 7912	09.08	09 18 560 6814	09.22	09 18 564 5814	09.22	09 18 564 7901	09.06	09 19 506 6324 741	22.31
09 18 550 7913	09.06	09 18 560 6901	09.06	09 18 564 5901	09.06	09 18 564 7902	09.08	09 19 506 6903	22.22
09 18 550 7914	09.08	09 18 560 6902	09.08	09 18 564 5902	09.08	09 18 564 7903	09.06	09 19 506 6904	22.24
09 18 550 7916	09.18	09 18 560 6903	09.06	09 18 564 5903	09.06	09 18 564 7904	09.08	09 19 506 6913	22.22
09 18 550 7917	09.18	09 18 560 6904	09.08	09 18 564 5904	09.08	09 18 564 7906	09.18	09 19 506 6914	22.24
		09 18 560 6906	09.18	09 18 564 5906	09.18	09 18 564 7907	09.18	09 19 506 6923	22.22
		09 18 560 6907	09.18	09 18 564 5907	09.18	09 18 564 7911	09.06	09 19 506 6924	22.24
		09 18 560 6911	09.06	09 18 564 5909	20.16	09 18 564 7912	09.08		
		09 18 560 6912	09.08	09 18 564 5911	09.06				
		09 18 560 6913	09.06	09 18 564 5912	09.08				

List of part numbers



Part No.	Page	Part No.	Page	Part No.	Page	Part No.	Page	Part No.	Page
09 19 506 6953	22.28	09 19 510 7324 741	22.31	09 19 516 5004	22.26	09 19 520 5913	22.22	09 19 524 6963	22.28
09 19 506 6963	22.28	09 19 510 7903	22.22	09 19 516 5014	22.26	09 19 520 5914	22.24	09 19 524 6973	22.28
09 19 506 6973	22.28	09 19 510 7904	22.24	09 19 516 5024	22.26	09 19 520 5923	22.22	09 19 524 7004	22.26
09 19 506 7004	22.26	09 19 510 7913	22.22	09 19 516 5323	22.30	09 19 520 5924	22.24	09 19 524 7014	22.26
09 19 506 7014	22.26	09 19 510 7914	22.24	09 19 516 5323 740	22.30	09 19 520 5953	22.28	09 19 524 7024	22.26
09 19 506 7024	22.26	09 19 510 7923	22.22	09 19 516 5323 741	22.30	09 19 520 5963	22.28	09 19 524 7903	22.22
09 19 506 7323	22.30	09 19 510 7924	22.24	09 19 516 5324	22.31	09 19 520 5973	22.28	09 19 524 7904	22.24
09 19 506 7323 740	22.30	09 19 510 7953	22.28	09 19 516 5324 740	22.31	09 19 520 6004	22.26	09 19 524 7913	22.22
09 19 506 7323 741	22.30	09 19 510 7963	22.28	09 19 516 5324 741	22.31	09 19 520 6014	22.26	09 19 524 7914	22.24
09 19 506 7324	22.31	09 19 510 7973	22.28	09 19 516 5903	22.22	09 19 520 6024	22.26	09 19 524 7923	22.22
09 19 506 7324 740	22.31			09 19 516 5904	22.24	09 19 520 6323	22.30	09 19 524 7924	22.24
09 19 506 7324 741	22.31			09 19 516 5913	22.22	09 19 520 6323 740	22.30	09 19 524 7953	22.28
09 19 506 7903	22.22			09 19 516 5914	22.24	09 19 520 6323 741	22.30	09 19 524 7963	22.28
09 19 506 7904	22.24	09 19 514 5004	22.26	09 19 516 5923	22.22	09 19 520 6324	22.31	09 19 524 7973	22.28
09 19 506 7913	22.22	09 19 514 5014	22.26	09 19 516 5924	22.24	09 19 520 6324 740	22.31		
09 19 506 7914	22.24	09 19 514 5024	22.26	09 19 516 5953	22.28	09 19 520 6324 741	22.31		
09 19 506 7923	22.22	09 19 514 5323	22.30	09 19 516 5963	22.28	09 19 520 6903	22.22	09 19 526 5004	22.26
09 19 506 7924	22.24	09 19 514 5323 740	22.30	09 19 516 5973	22.28	09 19 520 6904	22.24	09 19 526 5014	22.26
09 19 506 7953	22.28	09 19 514 5323 741	22.30	09 19 516 6004	22.26	09 19 520 6913	22.22	09 19 526 5024	22.26
09 19 506 7963	22.28	09 19 514 5324	22.31	09 19 516 6014	22.26	09 19 520 6914	22.24	09 19 526 5323	22.30
09 19 506 7973	22.28	09 19 514 5324 740	22.31	09 19 516 6024	22.26	09 19 520 6923	22.22	09 19 526 5323 740	22.30
		09 19 514 5324 741	22.31	09 19 516 6323	22.30	09 19 520 6924	22.24	09 19 526 5323 741	22.30
		09 19 514 5903	22.22	09 19 516 6323 740	22.30	09 19 520 6953	22.28	09 19 526 5324	22.31
		09 19 514 5904	22.24	09 19 516 6323 741	22.30	09 19 520 6963	22.28	09 19 526 5324 740	22.31
09 19 510 5004	22.26	09 19 514 5913	22.22	09 19 516 6324	22.31	09 19 520 6973	22.28	09 19 526 5324 741	22.31
09 19 510 5014	22.26	09 19 514 5914	22.24	09 19 516 6324 740	22.31	09 19 520 7004	22.26	09 19 526 5903	22.22
09 19 510 5024	22.26	09 19 514 5923	22.22	09 19 516 6324 741	22.31	09 19 520 7014	22.26	09 19 526 5904	22.24
09 19 510 5323	22.30	09 19 514 5924	22.24	09 19 516 6903	22.22	09 19 520 7024	22.26	09 19 526 5913	22.22
09 19 510 5323 740	22.30	09 19 514 5953	22.28	09 19 516 6904	22.24	09 19 520 7323	22.30	09 19 526 5914	22.24
09 19 510 5323 741	22.30	09 19 514 5963	22.28	09 19 516 6913	22.22	09 19 520 7323 740	22.30	09 19 526 5923	22.22
09 19 510 5324	22.31	09 19 514 5973	22.28	09 19 516 6914	22.24	09 19 520 7323 741	22.30	09 19 526 5924	22.24
09 19 510 5324 740	22.31	09 19 514 6004	22.26	09 19 516 6923	22.22	09 19 520 7324	22.31	09 19 526 5924	22.24
09 19 510 5324 741	22.31	09 19 514 6014	22.26	09 19 516 6924	22.24	09 19 520 7324 740	22.31	09 19 526 5953	22.28
09 19 510 5904	22.24	09 19 514 6024	22.26	09 19 516 6953	22.28	09 19 520 7324 741	22.31	09 19 526 5963	22.28
09 19 510 5913	22.22	09 19 514 6323	22.30	09 19 516 6963	22.28	09 19 520 7903	22.22	09 19 526 5973	22.28
09 19 510 5914	22.24	09 19 514 6323 740	22.30	09 19 516 6973	22.28	09 19 520 7904	22.24	09 19 526 6004	22.26
09 19 510 5923	22.22	09 19 514 6323 741	22.30	09 19 516 7004	22.26	09 19 520 7913	22.22	09 19 526 6014	22.26
09 19 510 5924	22.24	09 19 514 6324	22.31	09 19 516 7014	22.26	09 19 520 7914	22.24	09 19 526 6024	22.26
09 19 510 5953	22.28	09 19 514 6324 740	22.31	09 19 516 7024	22.26	09 19 520 7923	22.22	09 19 526 6323	22.30
09 19 510 5963	22.28	09 19 514 6324 741	22.31	09 19 516 7323	22.30	09 19 520 7924	22.24	09 19 526 6323 740	22.30
09 19 510 5973	22.28	09 19 514 6903	22.22	09 19 516 7323 740	22.30	09 19 520 7953	22.28	09 19 526 6323 741	22.30
09 19 510 6004	22.26	09 19 514 6904	22.24	09 19 516 7323 741	22.30	09 19 520 7963	22.28	09 19 526 6324	22.31
09 19 510 6014	22.26	09 19 514 6913	22.22	09 19 516 7324	22.31	09 19 520 7963	22.28	09 19 526 6324 740	22.31
09 19 510 6024	22.26	09 19 514 6914	22.24	09 19 516 7324 740	22.31	09 19 520 7973	22.28	09 19 526 6324 741	22.31
09 19 510 6024	22.26	09 19 514 6923	22.22	09 19 516 7324 741	22.31			09 19 526 6903	22.22
09 19 510 6323	22.30	09 19 514 6924	22.24	09 19 516 7903	22.22			09 19 526 6904	22.24
09 19 510 6323 740	22.30	09 19 514 6924	22.24	09 19 516 7904	22.24	09 19 524 5004	22.26	09 19 526 6913	22.22
09 19 510 6323 741	22.30	09 19 514 6953	22.28	09 19 516 7904	22.24	09 19 524 5014	22.26	09 19 526 6914	22.24
09 19 510 6324	22.31	09 19 514 6963	22.28	09 19 516 7913	22.22	09 19 524 5024	22.26	09 19 526 6923	22.22
09 19 510 6324 740	22.31	09 19 514 6973	22.28	09 19 516 7914	22.24	09 19 524 5903	22.22	09 19 526 6923	22.22
09 19 510 6324 741	22.31	09 19 514 7004	22.26	09 19 516 7923	22.22	09 19 524 5904	22.24	09 19 526 6924	22.24
09 19 510 6903	22.22	09 19 514 7014	22.26	09 19 516 7924	22.24	09 19 524 5913	22.22	09 19 526 6953	22.28
09 19 510 6904	22.24	09 19 514 7024	22.26	09 19 516 7953	22.28	09 19 524 5914	22.24	09 19 526 6963	22.28
09 19 510 6913	22.22	09 19 514 7323	22.30	09 19 516 7963	22.28	09 19 524 5923	22.22	09 19 526 6973	22.28
09 19 510 6914	22.24	09 19 514 7323 740	22.30	09 19 516 7973	22.28	09 19 524 5924	22.24	09 19 526 7004	22.26
09 19 510 6923	22.22	09 19 514 7323 741	22.30			09 19 524 5953	22.28	09 19 526 7014	22.26
09 19 510 6924	22.24	09 19 514 7324	22.31			09 19 524 5963	22.28	09 19 526 7024	22.26
09 19 510 6953	22.28	09 19 514 7324 740	22.31	09 19 520 5004	22.26	09 19 524 5973	22.28	09 19 526 7323	22.30
09 19 510 6963	22.28	09 19 514 7324 741	22.31	09 19 520 5014	22.26	09 19 524 6004	22.26	09 19 526 7323 740	22.30
09 19 510 6973	22.28	09 19 514 7903	22.22	09 19 520 5024	22.26	09 19 524 6014	22.26	09 19 526 7323 741	22.30
09 19 510 7004	22.26	09 19 514 7904	22.24	09 19 520 5323	22.30	09 19 524 6024	22.26	09 19 526 7324	22.31
09 19 510 7014	22.26	09 19 514 7913	22.22	09 19 520 5323 740	22.30	09 19 524 6024	22.26	09 19 526 7324 740	22.31
09 19 510 7024	22.26	09 19 514 7914	22.24	09 19 520 5323 741	22.30	09 19 524 6903	22.22	09 19 526 7324 741	22.31
09 19 510 7323	22.30	09 19 514 7923	22.22	09 19 520 5324	22.31	09 19 524 6904	22.24	09 19 526 7903	22.22
09 19 510 7323 740	22.30	09 19 514 7924	22.24	09 19 520 5324 740	22.31	09 19 524 6913	22.22	09 19 526 7904	22.24
09 19 510 7323 741	22.30	09 19 514 7953	22.28	09 19 520 5324 741	22.31	09 19 524 6914	22.22	09 19 526 7913	22.22
09 19 510 7324	22.31	09 19 514 7963	22.28	09 19 520 5903	22.22	09 19 524 6923	22.22	09 19 526 7914	22.24
09 19 510 7324 740	22.31	09 19 514 7973	22.28	09 19 520 5904	22.24	09 19 524 6924	22.24	09 19 526 7923	22.22
						09 19 524 6953	22.28	09 19 526 7924	22.24

Part No.

List of part numbers



Part No.	Page	Part No.	Page	Part No.	Page	Part No.	Page	Part No.	Page
09 19 526 7953	22.28	09 19 534 5324 740	22.31	09 19 540 6004	22.26	09 19 550 7014	22.26	09 19 564 5923	22.22
09 19 526 7963	22.28	09 19 534 5324 741	22.31	09 19 540 6014	22.26	09 19 550 7024	22.26	09 19 564 5924	22.24
09 19 526 7973	22.28	09 19 534 5903	22.22	09 19 540 6024	22.26	09 19 550 7323	22.30	09 19 564 5953	22.28
		09 19 534 5904	22.24	09 19 540 6323	22.30	09 19 550 7324	22.31	09 19 564 5963	22.28
		09 19 534 5913	22.22	09 19 540 6323 740	22.30	09 19 550 7903	22.22	09 19 564 5973	22.28
09 19 530 5004	22.26	09 19 534 5914	22.24	09 19 540 6323 741	22.30	09 19 550 7904	22.24	09 19 564 6004	22.26
09 19 530 5014	22.26	09 19 534 5923	22.22	09 19 540 6324	22.31	09 19 550 7913	22.22	09 19 564 6014	22.26
09 19 530 5024	22.26	09 19 534 5924	22.24	09 19 540 6324 740	22.31	09 19 550 7914	22.24	09 19 564 6024	22.26
09 19 530 5323	22.30	09 19 534 5953	22.28	09 19 540 6324 741	22.31	09 19 550 7923	22.22	09 19 564 6323	22.30
09 19 530 5323 740	22.30	09 19 534 5963	22.28	09 19 540 6903	22.22	09 19 550 7924	22.24	09 19 564 6324	22.31
09 19 530 5323 741	22.30	09 19 534 5973	22.28	09 19 540 6904	22.24	09 19 550 7953	22.28	09 19 564 6903	22.22
09 19 530 5324	22.31	09 19 534 6004	22.26	09 19 540 6913	22.22	09 19 550 7963	22.28	09 19 564 6904	22.24
09 19 530 5324 740	22.31	09 19 534 6014	22.26	09 19 540 6914	22.24	09 19 550 7973	22.28	09 19 564 6913	22.22
09 19 530 5324 741	22.31	09 19 534 6024	22.26	09 19 540 6923	22.22			09 19 564 6914	22.24
09 19 530 5903	22.22	09 19 534 6323	22.30	09 19 540 6924	22.24	09 19 560 5004	22.26	09 19 564 6923	22.22
09 19 530 5904	22.24	09 19 534 6323 740	22.30	09 19 540 6953	22.28	09 19 560 5014	22.26	09 19 564 6924	22.24
09 19 530 5913	22.22	09 19 534 6323 741	22.30	09 19 540 6963	22.28	09 19 560 5024	22.26	09 19 564 6953	22.28
09 19 530 5914	22.24	09 19 534 6324	22.31	09 19 540 6973	22.28	09 19 560 5323	22.30	09 19 564 6963	22.28
09 19 530 5923	22.22	09 19 534 6324 740	22.31	09 19 540 7004	22.26	09 19 560 5324	22.31	09 19 564 6973	22.28
09 19 530 5924	22.24	09 19 534 6324 741	22.31	09 19 540 7014	22.26	09 19 560 5903	22.22	09 19 564 7004	22.26
09 19 530 5953	22.28	09 19 534 6903	22.22	09 19 540 7024	22.26	09 19 560 5904	22.24	09 19 564 7014	22.26
09 19 530 5963	22.28	09 19 534 6904	22.24	09 19 540 7323	22.30	09 19 560 5913	22.22	09 19 564 7024	22.26
09 19 530 5973	22.28	09 19 534 6913	22.22	09 19 540 7323 740	22.30	09 19 560 5914	22.24	09 19 564 7323	22.30
09 19 530 6004	22.26	09 19 534 6914	22.24	09 19 540 7323 741	22.30	09 19 560 5923	22.24	09 19 564 7324	22.31
09 19 530 6014	22.26	09 19 534 6923	22.22	09 19 540 7324	22.31	09 19 560 5924	22.24	09 19 564 7903	22.22
09 19 530 6024	22.26	09 19 534 6924	22.24	09 19 540 7324 740	22.31	09 19 560 5953	22.28	09 19 564 7904	22.24
09 19 530 6323	22.30	09 19 534 6953	22.28	09 19 540 7324 741	22.31	09 19 560 5963	22.28	09 19 564 7913	22.22
09 19 530 6323 740	22.30	09 19 534 6963	22.28	09 19 540 7903	22.22	09 19 560 5973	22.28	09 19 564 7914	22.24
09 19 530 6323 741	22.30	09 19 534 6973	22.28	09 19 540 7904	22.24	09 19 560 6004	22.26	09 19 564 7923	22.22
09 19 530 6324	22.31	09 19 534 7004	22.26	09 19 540 7913	22.22	09 19 560 6014	22.26	09 19 564 7924	22.24
09 19 530 6324 740	22.31	09 19 534 7014	22.26	09 19 540 7914	22.24	09 19 560 6024	22.26	09 19 564 7953	22.28
09 19 530 6324 741	22.31	09 19 534 7024	22.26	09 19 540 7923	22.22	09 19 560 6323	22.30	09 19 564 7963	22.28
09 19 530 6903	22.22	09 19 534 7323	22.30	09 19 540 7924	22.24	09 19 560 6324	22.31	09 19 564 7973	22.28
09 19 530 6904	22.24	09 19 534 7323 740	22.30	09 19 540 7953	22.28	09 19 560 6903	22.22		
09 19 530 6913	22.22	09 19 534 7323 741	22.30	09 19 540 7963	22.28	09 19 560 6904	22.24	09 55 115 6611 741	21.08
09 19 530 6914	22.24	09 19 534 7324	22.31	09 19 540 7973	22.28	09 19 560 6913	22.22	09 55 115 6612 741	21.08
09 19 530 6923	22.22	09 19 534 7324 740	22.31			09 19 560 6914	22.24	09 55 115 6621 741	21.08
09 19 530 6924	22.24	09 19 534 7324 741	22.31	09 19 550 5004	22.26	09 19 560 6923	22.22	09 55 115 6622 741	21.08
09 19 530 6953	22.28	09 19 534 7903	22.22	09 19 550 5014	22.26	09 19 560 6924	22.24	09 55 115 7611 741	21.08
09 19 530 6963	22.28	09 19 534 7904	22.24	09 19 550 5024	22.26	09 19 560 6953	22.28	09 55 115 7612 741	21.08
09 19 530 6973	22.28	09 19 534 7913	22.22	09 19 550 5323	22.30	09 19 560 6963	22.28	09 55 115 7621 741	21.08
09 19 530 7004	22.26	09 19 534 7914	22.24	09 19 550 5324	22.31	09 19 560 6973	22.28	09 55 115 7622 741	21.08
09 19 530 7014	22.26	09 19 534 7923	22.22	09 19 550 5903	22.22	09 19 560 7004	22.26		
09 19 530 7024	22.26	09 19 534 7924	22.24	09 19 550 5904	22.24	09 19 560 7014	22.26	09 55 129 6811 741	21.08
09 19 530 7323	22.30	09 19 534 7953	22.28	09 19 550 5904	22.24	09 19 560 7024	22.26	09 55 129 6812 741	21.08
09 19 530 7323 740	22.30	09 19 534 7963	22.28	09 19 550 5913	22.22	09 19 560 7323	22.30	09 55 129 6821 741	21.08
09 19 530 7323 741	22.30	09 19 534 7973	22.28	09 19 550 5914	22.24	09 19 560 7324	22.31	09 55 129 6822 741	21.08
09 19 530 7324	22.31			09 19 550 5923	22.22	09 19 560 7903	22.22	09 55 129 7811 741	21.08
09 19 530 7324 740	22.31			09 19 550 5924	22.24	09 19 560 7904	22.24	09 55 129 7812 741	21.08
09 19 530 7324 741	22.31	09 19 540 5004	22.26	09 19 550 5953	22.28	09 19 560 7913	22.22	09 55 129 7821 741	21.08
09 19 530 7903	22.22	09 19 540 5014	22.26	09 19 550 5963	22.28	09 19 560 7914	22.24	09 55 129 7822 741	21.08
09 19 530 7904	22.24	09 19 540 5024	22.26	09 19 550 5973	22.28	09 19 560 7923	22.22		
09 19 530 7913	22.22	09 19 540 5323	22.30	09 19 550 6004	22.26	09 19 560 7924	22.24	09 55 155 6611 741	21.10
09 19 530 7914	22.24	09 19 540 5323 740	22.30	09 19 550 6014	22.26	09 19 560 7953	22.28	09 55 155 6612 741	21.10
09 19 530 7923	22.22	09 19 540 5323 741	22.30	09 19 550 6024	22.26	09 19 560 7963	22.28	09 55 155 6621 741	21.10
09 19 530 7924	22.24	09 19 540 5324	22.31	09 19 550 6323	22.30	09 19 560 7973	22.28	09 55 155 6622 741	21.10
09 19 530 7953	22.28	09 19 540 5324 740	22.31	09 19 550 6324	22.31			09 55 155 7611 741	21.10
09 19 530 7963	22.28	09 19 540 5324 741	22.31	09 19 550 6903	22.22	09 19 564 5004	22.26	09 55 155 7612 741	21.10
09 19 530 7973	22.28	09 19 540 5903	22.22	09 19 550 6904	22.24	09 19 564 5014	22.26	09 55 155 7621 741	21.10
		09 19 540 5904	22.24	09 19 550 6913	22.22	09 19 564 5024	22.26	09 55 155 7622 741	21.10
		09 19 540 5913	22.22	09 19 550 6914	22.24	09 19 564 5323	22.30		
09 19 534 5004	22.26	09 19 540 5914	22.24	09 19 550 6923	22.22	09 19 564 5324	22.31	09 55 156 6611 741	21.04
09 19 534 5014	22.26	09 19 540 5923	22.22	09 19 550 6924	22.24	09 19 564 5903	22.22	09 55 156 6612 741	21.04
09 19 534 5024	22.26	09 19 540 5924	22.24	09 19 550 6953	22.28	09 19 564 5904	22.24	09 55 156 6615 741	21.06
09 19 534 5323	22.30	09 19 540 5953	22.28	09 19 550 6963	22.28	09 19 564 5913	22.22	09 55 156 6616 741	21.06
09 19 534 5323 740	22.30	09 19 540 5963	22.28	09 19 550 6973	22.28	09 19 564 5914	22.24		
09 19 534 5323 741	22.30	09 19 540 5973	22.28	09 19 550 7004	22.26				
09 19 534 5324	22.31								

List of part numbers



Part No.	Page	Part No.	Page	Part No.	Page	Part No.	Page	Part No.	Page
09 56 300 5604	03.06	09 56 551 5500	03.11	09 64 113 7802	05.05	09 64 122 7228	05.12	09 64 211 7228	05.30
09 56 300 5615 050	03.06	09 56 551 5512	03.12			09 64 122 7230	05.10	09 64 211 7230	05.28
		09 56 551 5513	03.12	09 64 114 7210	05.16	09 64 122 7235	05.14	09 64 211 7237	05.30
09 56 351 5500	03.11	09 56 551 7500	03.11	09 64 114 7211	05.18	09 64 122 7236	05.14	09 64 211 7238	05.30
09 56 351 5512	03.12	09 56 551 7512	03.12	09 64 114 7212	05.20	09 64 122 7237	05.12	09 64 211 7240	05.28
09 56 351 5513	03.12	09 56 551 7513	03.12	09 64 114 7213	05.20	09 64 122 7238	05.12	09 64 211 7247	05.30
09 56 351 7500	03.11			09 64 114 7214	05.24	09 64 122 7240	05.10	09 64 211 7248	05.30
09 56 351 7512	03.12	09 56 552 5612	03.08	09 64 114 7215	05.24	09 64 122 7245	05.14	09 64 211 7800	05.06
09 56 351 7513	03.12	09 56 552 5613	03.08	09 64 114 7216	05.22	09 64 122 7246	05.14		
		09 56 552 7612	03.08	09 64 114 7217	05.22	09 64 122 7247	05.12	09 64 212 7210	05.10
09 56 352 5612	03.08	09 56 552 7613	03.08	09 64 114 7218	05.26	09 64 122 7248	05.12	09 64 212 7215	05.14
09 56 352 5613	03.08			09 64 114 7219	05.26	09 64 122 7800	05.04	09 64 212 7216	05.14
09 56 352 7612	03.08	09 56 561 5700	03.11	09 64 114 7220	05.16			09 64 212 7217	05.12
09 56 352 7613	03.08	09 56 561 5712	03.12	09 64 114 7221	05.18	09 64 123 7802	05.05	09 64 212 7218	05.12
		09 56 561 5713	03.12	09 64 114 7222	05.20			09 64 212 7220	05.10
09 56 361 5700	03.11	09 56 561 7700	03.11	09 64 114 7223	05.20	09 64 124 7210	05.16	09 64 212 7225	05.14
09 56 361 5712	03.12	09 56 561 7712	03.12	09 64 114 7224	05.24	09 64 124 7211	05.18	09 64 212 7226	05.14
09 56 361 5713	03.12	09 56 561 7713	03.12	09 64 114 7225	05.24	09 64 124 7212	05.20	09 64 212 7227	05.12
09 56 361 7700	03.11			09 64 114 7226	05.22	09 64 124 7213	05.20	09 64 212 7228	05.12
09 56 361 7712	03.12	09 56 562 5812	03.08	09 64 114 7227	05.22	09 64 124 7214	05.24	09 64 212 7230	05.10
09 56 361 7713	03.12	09 56 562 5813	03.08	09 64 114 7228	05.26	09 64 124 7215	05.24	09 64 212 7235	05.14
		09 56 562 7812	03.08	09 64 114 7229	05.26	09 64 124 7216	05.22	09 64 212 7236	05.14
09 56 362 5812	03.08	09 56 562 7813	03.08	09 64 114 7230	05.16	09 64 124 7217	05.22	09 64 212 7237	05.12
09 56 362 5813	03.08			09 64 114 7231	05.18	09 64 124 7218	05.26	09 64 212 7238	05.12
09 56 362 7812	03.08			09 64 114 7232	05.20	09 64 124 7219	05.26	09 64 212 7240	05.10
09 56 362 7813	03.08			09 64 114 7233	05.20	09 64 124 7220	05.16	09 64 212 7245	05.14
		09 64 100 7210	05.09	09 64 114 7234	05.24	09 64 124 7221	05.18	09 64 212 7246	05.14
09 56 400 4701	03.03	09 64 100 7220	05.09	09 64 114 7235	05.24	09 64 124 7222	05.20	09 64 212 7247	05.12
09 56 400 4704	03.06	09 64 100 7230	05.09	09 64 114 7236	05.22	09 64 124 7223	05.20	09 64 212 7248	05.12
09 56 400 4715 050	03.06	09 64 100 7240	05.09	09 64 114 7237	05.22	09 64 124 7224	05.24	09 64 212 7800	05.04
09 56 400 5601	03.03			09 64 114 7238	05.26	09 64 124 7225	05.24		
09 56 400 5604	03.06	09 64 111 7210	05.28	09 64 114 7239	05.26	09 64 124 7226	05.22	09 64 213 7802	05.05
09 56 400 5615 050	03.06	09 64 111 7217	05.30	09 64 114 7240	05.16	09 64 124 7227	05.22		
		09 64 111 7218	05.30	09 64 114 7241	05.18	09 64 124 7228	05.26	09 64 214 7210	05.16
09 56 451 5500	03.11	09 64 111 7220	05.28	09 64 114 7242	05.20	09 64 124 7229	05.26	09 64 214 7211	05.18
09 56 451 5512	03.12	09 64 111 7227	05.30	09 64 114 7243	05.20	09 64 124 7230	05.16	09 64 214 7212	05.20
09 56 451 5513	03.12	09 64 111 7228	05.30	09 64 114 7244	05.24	09 64 124 7231	05.18	09 64 214 7213	05.20
09 56 451 7500	03.11	09 64 111 7230	05.28	09 64 114 7245	05.24	09 64 124 7232	05.20	09 64 214 7214	05.24
09 56 451 7512	03.12	09 64 111 7237	05.30	09 64 114 7246	05.22	09 64 124 7233	05.20	09 64 214 7215	05.24
09 56 451 7513	03.12	09 64 111 7238	05.30	09 64 114 7247	05.22	09 64 124 7234	05.24	09 64 214 7216	05.22
		09 64 111 7240	05.28	09 64 114 7248	05.26	09 64 124 7235	05.24	09 64 214 7217	05.22
09 56 452 5612	03.08	09 64 111 7247	05.30	09 64 114 7249	05.26	09 64 124 7236	05.22	09 64 214 7218	05.26
09 56 452 5613	03.08	09 64 111 7248	05.30			09 64 124 7237	05.22	09 64 214 7219	05.26
09 56 452 7612	03.08	09 64 111 7800	05.06	09 64 121 7210	05.28	09 64 124 7238	05.26	09 64 214 7220	05.16
09 56 452 7613	03.08			09 64 121 7217	05.30	09 64 124 7239	05.26	09 64 214 7221	05.18
		09 64 112 7210	05.10	09 64 121 7218	05.30	09 64 124 7240	05.16	09 64 214 7222	05.20
09 56 461 5700	03.11	09 64 112 7215	05.14	09 64 121 7220	05.28	09 64 124 7241	05.18	09 64 214 7223	05.20
09 56 461 5712	03.12	09 64 112 7216	05.14	09 64 121 7227	05.30	09 64 124 7242	05.20	09 64 214 7224	05.24
09 56 461 5713	03.12	09 64 112 7217	05.12	09 64 121 7228	05.30	09 64 124 7243	05.20	09 64 214 7225	05.24
09 56 461 7700	03.11	09 64 112 7218	05.12	09 64 121 7230	05.28	09 64 124 7244	05.24	09 64 214 7226	05.22
09 56 461 7712	03.12	09 64 112 7220	05.10	09 64 121 7237	05.30	09 64 124 7245	05.24	09 64 214 7227	05.22
09 56 461 7713	03.12	09 64 112 7225	05.14	09 64 121 7238	05.30	09 64 124 7246	05.22	09 64 214 7228	05.26
		09 64 112 7226	05.14	09 64 121 7240	05.28	09 64 124 7247	05.22	09 64 214 7229	05.26
09 56 462 5812	03.08	09 64 112 7227	05.12	09 64 121 7247	05.30	09 64 124 7248	05.26	09 64 214 7230	05.16
09 56 462 5813	03.08	09 64 112 7228	05.12	09 64 121 7248	05.30	09 64 124 7249	05.26	09 64 214 7231	05.18
09 56 462 7812	03.08	09 64 112 7229	05.10	09 64 121 7800	05.06			09 64 214 7232	05.20
09 56 462 7813	03.08	09 64 112 7230	05.10			09 64 200 7210	05.09	09 64 214 7233	05.20
		09 64 112 7235	05.14	09 64 122 7210	05.10	09 64 200 7220	05.09	09 64 214 7234	05.24
09 56 500 4701	03.03	09 64 112 7236	05.14	09 64 122 7215	05.14	09 64 200 7230	05.09	09 64 214 7235	05.24
09 56 500 4704	03.06	09 64 112 7237	05.12	09 64 122 7216	05.14	09 64 200 7240	05.09	09 64 214 7236	05.22
09 56 500 4715 050	03.06	09 64 112 7238	05.12	09 64 122 7217	05.12			09 64 214 7237	05.22
09 56 500 5601	03.03	09 64 112 7240	05.10	09 64 122 7218	05.12	09 64 211 7210	05.28	09 64 214 7238	05.26
09 56 500 5604	03.06	09 64 112 7245	05.14	09 64 122 7220	05.10	09 64 211 7217	05.30	09 64 214 7239	05.26
09 56 500 5615 050	03.06	09 64 112 7246	05.14	09 64 122 7225	05.14	09 64 211 7218	05.30	09 64 214 7240	05.16
		09 64 112 7247	05.12	09 64 122 7226	05.14	09 64 211 7220	05.28	09 64 214 7241	05.18
09 56 500 5604	03.06	09 64 112 7248	05.12	09 64 122 7227	05.12	09 64 211 7227	05.30	09 64 214 7242	05.20
09 56 500 5615 050	03.06	09 64 112 7800	05.04						

List of part numbers



Part No.	Page	Part No.	Page	Part No.	Page	Part No.	Page	Part No.	Page
09 64 214 7243	05.20	09 64 224 7230	05.16	09 64 314 7212	05.20	09 64 322 7237	05.12	09 64 411 7240	05.28
09 64 214 7244	05.24	09 64 224 7231	05.18	09 64 314 7213	05.20	09 64 322 7238	05.12	09 64 411 7247	05.30
09 64 214 7245	05.24	09 64 224 7232	05.20	09 64 314 7214	05.24	09 64 322 7240	05.10	09 64 411 7248	05.30
09 64 214 7246	05.22	09 64 224 7233	05.20	09 64 314 7215	05.24	09 64 322 7245	05.14	09 64 411 7800	05.06
09 64 214 7247	05.22	09 64 224 7234	05.24	09 64 314 7216	05.22	09 64 322 7246	05.14		
09 64 214 7248	05.26	09 64 224 7235	05.24	09 64 314 7217	05.22	09 64 322 7247	05.12	09 64 412 7210	05.10
09 64 214 7249	05.26	09 64 224 7236	05.22	09 64 314 7218	05.26	09 64 322 7248	05.12	09 64 412 7215	05.14
		09 64 224 7237	05.22	09 64 314 7219	05.26	09 64 322 7800	05.04	09 64 412 7216	05.14
		09 64 224 7238	05.26	09 64 314 7220	05.16			09 64 412 7217	05.12
09 64 221 7210	05.28	09 64 224 7239	05.26	09 64 314 7221	05.18	09 64 323 7802	05.05	09 64 412 7218	05.12
09 64 221 7217	05.30	09 64 224 7240	05.16	09 64 314 7222	05.20			09 64 412 7220	05.10
09 64 221 7218	05.30	09 64 224 7241	05.18	09 64 314 7223	05.20			09 64 412 7225	05.14
09 64 221 7220	05.28	09 64 224 7242	05.20	09 64 314 7224	05.24	09 64 324 7210	05.16	09 64 412 7226	05.14
09 64 221 7227	05.30	09 64 224 7243	05.20	09 64 314 7225	05.24	09 64 324 7211	05.18	09 64 412 7227	05.12
09 64 221 7228	05.30	09 64 224 7244	05.24	09 64 314 7226	05.22	09 64 324 7212	05.20	09 64 412 7228	05.12
09 64 221 7230	05.28	09 64 224 7245	05.24	09 64 314 7227	05.22	09 64 324 7213	05.20	09 64 412 7228	05.12
09 64 221 7237	05.30	09 64 224 7246	05.22	09 64 314 7228	05.26	09 64 324 7214	05.24	09 64 412 7230	05.10
09 64 221 7238	05.30	09 64 224 7247	05.22	09 64 314 7229	05.26	09 64 324 7215	05.24	09 64 412 7235	05.14
09 64 221 7240	05.28	09 64 224 7248	05.26	09 64 314 7230	05.16	09 64 324 7216	05.22	09 64 412 7236	05.14
09 64 221 7247	05.30	09 64 224 7249	05.26	09 64 314 7231	05.18	09 64 324 7217	05.22	09 64 412 7237	05.12
09 64 221 7248	05.30			09 64 314 7232	05.20	09 64 324 7218	05.26	09 64 412 7238	05.12
09 64 221 7800	05.06			09 64 314 7233	05.20	09 64 324 7219	05.26	09 64 412 7240	05.10
		09 64 300 7210	05.09	09 64 314 7234	05.24	09 64 324 7220	05.16	09 64 412 7245	05.14
		09 64 300 7220	05.09	09 64 314 7235	05.24	09 64 324 7221	05.18	09 64 412 7246	05.14
09 64 222 7210	05.10	09 64 300 7230	05.09	09 64 314 7236	05.22	09 64 324 7222	05.20	09 64 412 7247	05.12
09 64 222 7215	05.14	09 64 300 7240	05.09	09 64 314 7237	05.22	09 64 324 7223	05.20	09 64 412 7248	05.12
09 64 222 7216	05.14			09 64 314 7238	05.26	09 64 324 7224	05.24		
09 64 222 7217	05.12	09 64 311 7210	05.28	09 64 314 7239	05.26	09 64 324 7225	05.24	09 64 413 7802	05.05
09 64 222 7218	05.12	09 64 311 7217	05.30	09 64 314 7240	05.16	09 64 324 7226	05.22		
09 64 222 7220	05.10	09 64 311 7218	05.30	09 64 314 7241	05.18	09 64 324 7227	05.22	09 64 414 7210	05.16
09 64 222 7225	05.14	09 64 311 7220	05.28	09 64 314 7242	05.20	09 64 324 7228	05.26	09 64 414 7211	05.18
09 64 222 7226	05.14	09 64 311 7227	05.30	09 64 314 7243	05.20	09 64 324 7229	05.26	09 64 414 7212	05.20
09 64 222 7227	05.12	09 64 311 7228	05.30	09 64 314 7244	05.24	09 64 324 7230	05.16	09 64 414 7213	05.20
09 64 222 7228	05.12	09 64 311 7230	05.28	09 64 314 7245	05.24	09 64 324 7231	05.18	09 64 414 7214	05.24
09 64 222 7230	05.10	09 64 311 7237	05.30	09 64 314 7246	05.22	09 64 324 7232	05.20	09 64 414 7215	05.24
09 64 222 7235	05.14	09 64 311 7238	05.30	09 64 314 7247	05.22	09 64 324 7233	05.20	09 64 414 7216	05.22
09 64 222 7236	05.14	09 64 311 7240	05.28	09 64 314 7248	05.26	09 64 324 7234	05.24	09 64 414 7217	05.22
09 64 222 7237	05.12	09 64 311 7247	05.30	09 64 314 7249	05.26	09 64 324 7235	05.24	09 64 414 7218	05.26
09 64 222 7238	05.12	09 64 311 7248	05.30			09 64 324 7236	05.22	09 64 414 7219	05.26
09 64 222 7240	05.10	09 64 311 7800	05.06			09 64 324 7237	05.22	09 64 414 7220	05.16
09 64 222 7245	05.14			09 64 321 7210	05.28	09 64 324 7238	05.26	09 64 414 7221	05.18
09 64 222 7246	05.14			09 64 321 7217	05.30	09 64 324 7239	05.26	09 64 414 7222	05.20
09 64 222 7247	05.12	09 64 312 7210	05.10	09 64 321 7218	05.30	09 64 324 7240	05.16	09 64 414 7223	05.20
09 64 222 7248	05.12	09 64 312 7215	05.14	09 64 321 7220	05.28	09 64 324 7241	05.18	09 64 414 7224	05.24
09 64 222 7800	05.04	09 64 312 7216	05.14	09 64 321 7227	05.30	09 64 324 7242	05.20	09 64 414 7225	05.24
		09 64 312 7217	05.12	09 64 321 7228	05.30	09 64 324 7243	05.20	09 64 414 7226	05.22
09 64 223 7802	05.05	09 64 312 7218	05.12	09 64 321 7230	05.28	09 64 324 7244	05.24	09 64 414 7227	05.22
		09 64 312 7220	05.10	09 64 321 7237	05.30	09 64 324 7245	05.24	09 64 414 7228	05.26
		09 64 312 7225	05.14	09 64 321 7238	05.30	09 64 324 7246	05.22	09 64 414 7229	05.26
09 64 224 7210	05.16	09 64 312 7226	05.14	09 64 321 7240	05.28	09 64 324 7247	05.22	09 64 414 7230	05.16
09 64 224 7211	05.18	09 64 312 7227	05.12	09 64 321 7247	05.30	09 64 324 7248	05.26	09 64 414 7231	05.18
09 64 224 7212	05.20	09 64 312 7228	05.12	09 64 321 7248	05.30	09 64 324 7249	05.26	09 64 414 7232	05.20
09 64 224 7213	05.20	09 64 312 7230	05.10	09 64 321 7800	05.06			09 64 414 7233	05.20
09 64 224 7214	05.24	09 64 312 7235	05.14					09 64 414 7234	05.24
09 64 224 7215	05.24	09 64 312 7236	05.14					09 64 414 7235	05.24
09 64 224 7216	05.22	09 64 312 7237	05.12	09 64 322 7210	05.10	09 64 400 7210	05.09	09 64 414 7236	05.22
09 64 224 7217	05.22	09 64 312 7238	05.12	09 64 322 7215	05.14	09 64 400 7220	05.09	09 64 414 7237	05.22
09 64 224 7218	05.26	09 64 312 7240	05.10	09 64 322 7216	05.14	09 64 400 7230	05.09	09 64 414 7238	05.26
09 64 224 7219	05.26	09 64 312 7245	05.14	09 64 322 7217	05.12	09 64 400 7240	05.09	09 64 414 7239	05.26
09 64 224 7220	05.16	09 64 312 7246	05.14	09 64 322 7218	05.12			09 64 414 7240	05.16
09 64 224 7221	05.18	09 64 312 7247	05.12	09 64 322 7220	05.10	09 64 411 7210	05.28	09 64 414 7241	05.18
09 64 224 7222	05.20	09 64 312 7248	05.12	09 64 322 7225	05.14	09 64 411 7217	05.30	09 64 414 7242	05.20
09 64 224 7223	05.20	09 64 312 7249	05.12	09 64 322 7226	05.14	09 64 411 7218	05.30	09 64 414 7243	05.20
09 64 224 7224	05.24	09 64 312 7800	05.04	09 64 322 7227	05.12	09 64 411 7220	05.28	09 64 414 7244	05.24
09 64 224 7225	05.24			09 64 322 7228	05.12	09 64 411 7227	05.30	09 64 414 7245	05.24
09 64 224 7226	05.22	09 64 313 7802	05.05	09 64 322 7230	05.10	09 64 411 7228	05.30	09 64 414 7246	05.22
09 64 224 7227	05.22			09 64 322 7235	05.14	09 64 411 7230	05.28	09 64 414 7247	05.22
09 64 224 7228	05.26	09 64 314 7210	05.16	09 64 322 7236	05.14	09 64 411 7237	05.30		
09 64 224 7229	05.26	09 64 314 7211	05.18			09 64 411 7238	05.30		

Part No.

List of part numbers



Part No.	Page	Part No.	Page	Part No.	Page	Part No.	Page	Part No.	Page
09 64 414 7248	05.26	09 64 424 7236	05.22	09 65 162 7815	02.18	09 65 223 7802	02.14	09 65 269 6711	22.14
09 64 414 7249	05.26	09 64 424 7237	05.22	09 65 162 7816	02.18	09 65 223 7803	02.14	09 65 269 6712	22.14
		09 64 424 7238	05.26	09 65 162 7817	02.18			09 65 269 6713	22.14
		09 64 424 7239	05.26			09 65 229 6701	22.14	09 65 269 7711	22.14
09 64 421 7210	05.28	09 64 424 7240	05.16	09 65 163 6810	02.12	09 65 229 6702	22.14	09 65 269 7712	22.14
09 64 421 7217	05.30	09 64 424 7241	05.18	09 65 163 6811	02.12	09 65 229 6703	22.14	09 65 269 7713	22.14
09 64 421 7218	05.30	09 64 424 7242	05.20	09 65 163 6812	02.12	09 65 229 7701	22.14		
09 64 421 7220	05.28	09 64 424 7243	05.20	09 65 163 6813	02.12	09 65 229 7702	22.14	09 65 321 6701	02.06
09 64 421 7227	05.30	09 64 424 7244	05.24	09 65 163 7810	02.12	09 65 229 7703	22.14	09 65 321 6702	02.06
09 64 421 7228	05.30	09 64 424 7245	05.24	09 65 163 7811	02.12			09 65 321 6703	02.06
09 64 421 7230	05.28	09 64 424 7246	05.22	09 65 163 7812	02.12	09 65 261 6711	02.06	09 65 321 7701	02.06
09 64 421 7237	05.30	09 64 424 7247	05.22	09 65 163 7813	02.12	09 65 261 6712	02.06	09 65 321 7702	02.06
09 64 421 7238	05.30	09 64 424 7248	05.26			09 65 261 6713	02.06	09 65 321 7703	02.06
09 64 421 7240	05.28	09 64 424 7249	05.26	09 65 166 6810	22.16	09 65 261 7711	02.06	09 65 322 6800	02.14
09 64 421 7247	05.30			09 65 166 6811	22.16	09 65 261 7712	02.06	09 65 322 6801	02.14
09 64 421 7248	05.30			09 65 166 6812	22.16	09 65 261 7713	02.06	09 65 322 6802	02.14
06 64 421 7800	05.06	09 65 121 6701	02.06	09 65 166 6813	22.16			09 65 322 6803	02.14
		09 65 121 6702	02.06	09 65 166 6815	22.18	09 65 262 6810	02.12	09 65 322 7800	02.14
09 64 422 7210	05.10	09 65 121 6703	02.06	09 65 166 6816	22.18	09 65 262 6811	02.12	09 65 322 7801	02.14
09 64 422 7215	05.14	09 65 121 7701	02.06	09 65 166 6817	22.18	09 65 262 6812	02.12	09 65 322 7802	02.14
09 64 422 7216	05.14	09 65 121 7702	02.06	09 65 166 7810	22.16	09 65 262 6813	02.12	09 65 322 7803	02.14
09 64 422 7217	05.12	09 65 121 7703	02.06	09 65 166 7811	22.16	09 65 262 6815	02.18		
09 64 422 7218	05.12			09 65 166 7812	22.16	09 65 262 6816	02.18	09 65 323 6800	02.14
09 64 422 7220	05.10	09 65 122 6800	02.14	09 65 166 7813	22.16	09 65 262 6817	02.18	09 65 323 6801	02.14
09 64 422 7225	05.14	09 65 122 6801	02.14	09 65 166 7815	22.18	09 65 262 7810	02.12	09 65 323 6802	02.14
09 64 422 7226	05.14	09 65 122 6802	02.14	09 65 166 7816	22.18	09 65 262 7811	02.12	09 65 323 6803	02.14
09 64 422 7227	05.12	09 65 122 6803	02.14	09 65 166 7817	22.18	09 65 262 7812	02.12	09 65 323 7800	02.14
09 64 422 7228	05.12	09 65 122 7800	02.14			09 65 262 7813	02.12	09 65 323 7801	02.14
09 64 422 7230	05.10	09 65 122 7801	02.14	09 65 167 6810	22.16	09 65 262 7815	02.18	09 65 323 7802	02.14
09 64 422 7235	05.14	09 65 122 7802	02.14	09 65 167 6811	22.16	09 65 262 7816	02.18	09 65 323 7803	02.14
09 64 422 7236	05.14	09 65 122 7803	02.14	09 65 167 6812	22.16	09 65 262 7817	02.18		
09 64 422 7237	05.12			09 65 167 6813	22.16			09 65 329 6701	22.14
09 64 422 7238	05.12	09 65 123 6800	02.14	09 65 167 7810	22.16	09 65 263 6810	02.12	09 65 329 6702	22.14
09 64 422 7240	05.10	09 65 123 6801	02.14	09 65 167 7811	22.16	09 65 263 6811	02.12	09 65 329 6703	22.14
09 64 422 7245	05.14	09 65 123 6802	02.14	09 65 167 7812	22.16	09 65 263 6812	02.12	09 65 329 7701	22.14
09 64 422 7246	05.14	09 65 123 6803	02.14	09 65 167 7813	22.16	09 65 263 6813	02.12	09 65 329 7702	22.14
09 64 422 7247	05.12	09 65 123 7800	02.14			09 65 263 7810	02.12	09 65 329 7703	22.14
09 64 422 7248	05.12	09 65 123 7801	02.14	09 65 169 6711	22.14	09 65 263 7811	02.12		
		09 65 123 7802	02.14	09 65 169 6712	22.14	09 65 263 7812	02.12	09 65 361 6711	02.06
09 64 423 7802	05.05	09 65 123 7803	02.14	09 65 169 6713	22.14	09 65 263 7813	02.12	09 65 361 6712	02.06
				09 65 169 7711	22.14			09 65 361 6713	02.06
		09 65 129 6701	22.14	09 65 169 7712	22.14			09 65 361 7711	02.06
09 64 424 7210	05.16	09 65 129 6702	22.14	09 65 169 7713	22.14	09 65 266 6810	22.16	09 65 361 7712	02.06
09 64 424 7211	05.18	09 65 129 6703	22.14			09 65 266 6811	22.16	09 65 361 7713	02.06
09 64 424 7212	05.20	09 65 129 7701	22.14	09 65 221 6701	02.06	09 65 266 6812	22.16		
09 64 424 7213	05.20	09 65 129 7702	22.14	09 65 221 6702	02.06	09 65 266 6813	22.16	09 65 362 6810	02.12
09 64 424 7214	05.24	09 65 129 7703	22.14	09 65 221 6703	02.06	09 65 266 6815	22.18	09 65 362 6811	02.12
09 64 424 7215	05.24			09 65 221 7701	02.06	09 65 266 6816	22.18	09 65 362 6812	02.12
09 64 424 7216	05.22	09 65 161 6711	02.06	09 65 221 7702	02.06	09 65 266 6817	22.18	09 65 362 6813	02.12
09 64 424 7217	05.22	09 65 161 6712	02.06	09 65 221 7703	02.06	09 65 266 7810	22.16	09 65 362 6815	02.18
09 64 424 7218	05.26	09 65 161 6713	02.06			09 65 266 7811	22.16	09 65 362 6816	02.18
09 64 424 7219	05.26	09 65 161 7711	02.06	09 65 222 6800	02.14	09 65 266 7812	22.16	09 65 362 6817	02.18
09 64 424 7220	05.16	09 65 161 7712	02.06	09 65 222 6801	02.14	09 65 266 7813	22.16	09 65 362 7810	02.12
09 64 424 7221	05.18	09 65 161 7713	02.06	09 65 222 6802	02.14	09 65 266 7815	22.18	09 65 362 7811	02.12
09 64 424 7222	05.20			09 65 222 6803	02.14	09 65 266 7816	22.18	09 65 362 7812	02.12
09 64 424 7223	05.20	09 65 162 6810	02.12	09 65 222 7800	02.14	09 65 266 7817	22.18	09 65 362 7813	02.12
09 64 424 7224	05.24	09 65 162 6811	02.12	09 65 222 7801	02.14			09 65 362 7815	02.18
09 64 424 7225	05.24	09 65 162 6812	02.12	09 65 222 7802	02.14			09 65 362 7816	02.18
09 64 424 7226	05.22	09 65 162 6813	02.12	09 65 222 7803	02.14	09 65 267 6810	22.16	09 65 362 7817	02.18
09 64 424 7227	05.22	09 65 162 6815	02.18			09 65 267 6811	22.16		
09 64 424 7228	05.26	09 65 162 6816	02.18	09 65 223 6800	02.14	09 65 267 6812	22.16	09 65 363 6810	02.12
09 64 424 7229	05.26	09 65 162 6817	02.18	09 65 223 6801	02.14	09 65 267 6813	22.16	09 65 363 6811	02.12
09 64 424 7230	05.16	09 65 162 7810	02.12	09 65 223 6802	02.14	09 65 267 7810	22.16	09 65 363 6812	02.12
09 64 424 7231	05.18	09 65 162 7811	02.12	09 65 223 6803	02.14	09 65 267 7811	22.16	09 65 363 6813	02.12
09 64 424 7232	05.20	09 65 162 7812	02.12	09 65 223 7800	02.14	09 65 267 7812	22.16	09 65 363 7810	02.12
09 64 424 7233	05.20	09 65 162 7813	02.12	09 65 223 7801	02.14	09 65 267 7813	22.16		
09 64 424 7234	05.24								
09 64 424 7235	05.24								

List of part numbers



Part No.	Page	Part No.	Page	Part No.	Page	Part No.	Page	Part No.	Page
09 65 363 7811	02.12	09 65 461 6711	02.06	09 66 108 0001	02.32	09 66 122 6801	02.10	09 66 154 6517	20.10
09 65 363 7812	02.12	09 65 461 6712	02.06			09 66 122 6802	02.10	09 66 154 7511	20.10
09 65 363 7813	02.12	09 65 461 6713	02.06	09 66 111 6501	02.06	09 66 122 6803	02.10	09 66 154 7512	20.10
		09 65 461 7711	02.06	09 66 111 6502	02.06	09 66 122 7801	02.10	09 66 154 7513	20.10
09 65 366 6810	22.16	09 65 461 7712	02.06	09 66 111 6503	02.06	09 66 122 7802	02.10	09 66 154 7515	20.10
09 65 366 6811	22.16	09 65 461 7713	02.06	09 66 111 7501	02.06	09 66 122 7803	02.10	09 66 154 7516	20.10
09 65 366 6812	22.16			09 66 111 7502	02.06			09 66 154 7517	20.10
09 65 366 6813	22.16	09 65 462 6810	02.12	09 66 111 7503	02.06	09 66 123 6801	02.10		
09 65 366 6815	22.18	09 65 462 6811	02.12			09 66 123 6802	02.10	09 66 155 6511	22.14
09 65 366 6816	22.18	09 65 462 6812	02.12	09 66 112 6600	02.14	09 66 123 6803	02.10	09 66 155 6512	22.14
09 65 366 6817	22.18	09 65 462 6813	02.12	09 66 112 6601	02.14	09 66 123 7801	02.10	09 66 155 6513	22.14
		09 65 462 6815	02.18	09 66 112 6602	02.14	09 66 123 7802	02.10	09 66 155 7511	22.14
09 65 366 7810	22.16	09 65 462 6816	02.18	09 66 112 6603	02.14	09 66 123 7803	02.10	09 66 155 7512	22.14
09 65 366 7811	22.16	09 65 462 6817	02.18	09 66 112 7600	02.14			09 66 155 7513	22.14
09 65 366 7812	22.16	09 65 462 7810	02.12	09 66 112 7601	02.14	09 66 124 6704	20.12		
09 65 366 7813	22.16	09 65 462 7811	02.12	09 66 112 7602	02.14	09 66 124 6705	20.12	09 66 156 6610	22.16
09 65 366 7815	22.18	09 65 462 7812	02.12	09 66 112 7603	02.14	09 66 124 6706	20.12	09 66 156 6611	22.16
09 65 366 7816	22.18	09 65 462 7813	02.12			09 66 124 6707	20.12	09 66 156 6612	22.16
09 65 366 7817	22.18	09 65 462 7815	02.18	09 66 113 6600	02.14	09 66 124 7704	20.12	09 66 156 6613	22.16
		09 65 462 7816	02.18	09 66 113 6601	02.14	09 66 124 7705	20.12	09 66 156 6615	22.18
09 65 367 6810	22.16	09 65 462 7817	02.18	09 66 113 6602	02.14	09 66 124 7706	20.12	09 66 156 6616	22.18
09 65 367 6811	22.16			09 66 113 6603	02.14	09 66 124 7707	20.12	09 66 156 6617	22.18
09 65 367 6812	22.16	09 65 463 6810	02.12	09 66 113 7600	02.14			09 66 156 7610	22.16
09 65 367 6813	22.16	09 65 463 6811	02.12	09 66 113 7601	02.14	09 66 128 6700	02.32	09 66 156 7611	22.16
09 65 367 7810	22.16	09 65 463 6812	02.12	09 66 113 7602	02.14	09 66 128 6701	02.32	09 66 156 7612	22.16
09 65 367 7811	22.16	09 65 463 6813	02.12	09 66 113 7603	02.14	09 66 128 6702	02.32	09 66 156 7613	22.16
09 65 367 7812	22.16	09 65 463 7810	02.12			09 66 128 7700	02.32	09 66 156 7615	22.18
09 65 367 7813	22.16	09 65 463 7811	02.12	09 66 114 6500	20.12	09 66 128 7701	02.32	09 66 156 7616	22.18
		09 65 463 7812	02.12	09 66 114 6501	20.12	09 66 128 7702	02.32	09 66 156 7617	22.18
09 65 369 6711	22.14	09 65 463 7813	02.12	09 66 114 6502	20.12				
09 65 369 6712	22.14			09 66 114 6503	20.12	09 66 151 6511	02.06	09 66 157 6610	22.16
09 65 369 6713	22.14	09 65 466 6810	22.16	09 66 114 6504	20.12	09 66 151 6512	02.06	09 66 157 6611	22.16
09 65 369 7711	22.14	09 65 466 6811	22.16	09 66 114 6505	20.12	09 66 151 6513	02.06	09 66 157 6612	22.16
09 65 369 7712	22.14	09 65 466 6812	22.16	09 66 114 6506	20.12	09 66 151 7511	02.06	09 66 157 6613	22.16
09 65 369 7713	22.14	09 65 466 6813	22.16	09 66 114 6507	20.12	09 66 151 7512	02.06	09 66 157 6616	22.18
		09 65 466 6815	22.18	09 66 114 7500	20.12	09 66 151 7513	02.06	09 66 157 7610	22.16
09 65 421 6701	02.06	09 65 466 6816	22.18	09 66 114 7501	20.12			09 66 157 7611	22.16
09 65 421 6702	02.06	09 65 466 6817	22.18	09 66 114 7502	20.12	09 66 152 6610	02.12	09 66 157 7612	22.16
09 65 421 6703	02.06	09 65 466 6815	22.18	09 66 114 7503	20.12	09 66 152 6611	02.12	09 66 157 7613	22.16
09 65 421 7701	02.06	09 65 466 6816	22.18	09 66 114 7504	20.12	09 66 152 6612	02.12		
09 65 421 7702	02.06	09 65 466 6817	22.18	09 66 114 7505	20.12	09 66 152 6613	02.12	09 66 162 6811	02.10
09 65 421 7703	02.06	09 65 466 7810	22.16	09 66 114 7506	20.12	09 66 152 6615	02.18	09 66 162 6812	02.10
		09 65 466 7812	22.16	09 66 114 7507	20.12	09 66 152 6616	02.18	09 66 162 6813	02.10
09 65 422 6800	02.14	09 65 466 7813	22.16			09 66 152 6617	02.18	09 66 162 6815	02.16
09 65 422 6801	02.14	09 65 466 7815	22.18	09 66 115 6501	22.14	09 66 152 7610	02.12	09 66 162 6816	02.16
09 65 422 6802	02.14	09 65 466 7816	22.18	09 66 115 6502	22.14	09 66 152 7611	02.12	09 66 162 6817	02.16
09 65 422 6803	02.14	09 65 466 7817	22.18	09 66 115 6503	22.14	09 66 152 7612	02.12	09 66 162 7811	02.10
09 65 422 7800	02.14			09 66 115 7501	22.14	09 66 152 7613	02.12	09 66 162 7812	02.10
09 65 422 7801	02.14	09 65 467 6810	22.16	09 66 115 7502	22.14	09 66 152 7615	02.18	09 66 162 7813	02.10
09 65 422 7802	02.14	09 65 467 6811	22.16	09 66 115 7503	22.14	09 66 152 7616	02.18	09 66 162 7815	02.16
09 65 422 7803	02.14	09 65 467 6812	22.16			09 66 152 7617	02.18	09 66 162 7816	02.16
		09 65 467 6813	22.16	09 66 118 6500	02.32			09 66 162 7817	02.16
09 65 423 6800	02.14	09 65 467 6815	22.18	09 66 118 6501	02.32	09 66 153 6610	02.12		
09 65 423 6801	02.14	09 65 467 6816	22.18	09 66 118 6502	02.32	09 66 153 6611	02.12	09 66 163 6811	02.10
09 65 423 6802	02.14	09 65 467 6817	22.18	09 66 118 6503	02.32	09 66 153 6612	02.12	09 66 163 6812	02.10
09 65 423 6803	02.14			09 66 118 7500	02.32	09 66 153 6613	02.12	09 66 163 6813	02.10
09 65 423 7800	02.14	09 65 469 6711	22.14	09 66 118 7501	02.32	09 66 153 7610	02.12	09 66 163 7811	02.10
09 65 423 7801	02.14	09 65 469 6712	22.14	09 66 118 7502	02.32	09 66 153 7611	02.12	09 66 163 7812	02.10
09 65 423 7802	02.14	09 65 469 6713	22.14			09 66 153 7612	02.12	09 66 163 7813	02.10
09 65 423 7803	02.14	09 65 469 7711	22.14	09 66 121 6701	02.05	09 66 153 7613	02.12		
		09 65 469 7712	22.14	09 66 121 6702	02.05			09 66 164 6715	20.10
09 65 429 6701	22.14	09 65 469 7713	22.14	09 66 121 6703	02.05	09 66 154 6511	20.10	09 66 164 6716	20.10
09 65 429 6702	22.14			09 66 121 7701	02.05	09 66 154 6512	20.10	09 66 164 6717	20.10
09 65 429 6703	22.14	09 66 000 9972	08.02	09 66 121 7702	02.05	09 66 154 6513	20.10	09 66 164 7715	20.10
09 65 429 7701	22.14	09 66 000 9974	08.02	09 66 121 7703	02.05	09 66 154 6515	20.10	09 66 164 7716	20.10
09 65 429 7702	22.14					09 66 154 6516	20.10	09 66 164 7717	20.10
09 65 429 7703	22.14								

Part No.

List of part numbers



Part No.	Page	Part No.	Page	Part No.	Page	Part No.	Page	Part No.	Page
09 66 208 0001	02.32	09 66 222 6801	02.10	09 66 254 6517	20.10	09 66 308 0001	02.32	09 66 322 6801	02.10
		09 66 222 6802	02.10	09 66 254 7511	20.10			09 66 322 6802	02.10
09 66 211 6501	02.06	09 66 222 6803	02.10	09 66 254 7512	20.10	09 66 311 6501	02.06	09 66 322 6803	02.10
09 66 211 6502	02.06	09 66 222 7801	02.10	09 66 254 7513	20.10	09 66 311 6502	02.06	09 66 322 7801	02.10
09 66 211 6503	02.06	09 66 222 7802	02.10	09 66 254 7515	20.10	09 66 311 6503	02.06	09 66 322 7802	02.10
09 66 211 7501	02.06	09 66 222 7803	02.10	09 66 254 7516	20.10	09 66 311 7501	02.06	09 66 322 7803	02.10
09 66 211 7502	02.06			09 66 254 7517	20.10	09 66 311 7502	02.06		
09 66 211 7503	02.06	09 66 223 6801	02.10			09 66 311 7503	02.06	09 66 323 6801	02.10
		09 66 223 6802	02.10	09 66 255 6511	22.14			09 66 323 6802	02.10
		09 66 223 6803	02.10	09 66 255 6512	22.14	09 66 312 6600	02.14	09 66 323 6803	02.10
09 66 212 6600	02.14	09 66 223 7801	02.10	09 66 255 6513	22.14	09 66 312 6601	02.14	09 66 323 7801	02.10
09 66 212 6601	02.14	09 66 223 7802	02.10	09 66 255 7511	22.14	09 66 312 6602	02.14	09 66 323 7802	02.10
09 66 212 6602	02.14	09 66 223 7803	02.10	09 66 255 7512	22.14	09 66 312 6603	02.14	09 66 323 7803	02.10
09 66 212 6603	02.14			09 66 255 7513	22.14	09 66 312 7600	02.14		
09 66 212 7600	02.14	09 66 224 6704	20.12			09 66 312 7601	02.14	09 66 324 6704	20.12
09 66 212 7601	02.14	09 66 224 6705	20.12	09 66 256 6610	22.16	09 66 312 7602	02.14	09 66 324 6705	20.12
09 66 212 7602	02.14	09 66 224 6706	20.12	09 66 256 6611	22.16	09 66 312 7603	02.14	09 66 324 6706	20.12
09 66 212 7603	02.14	09 66 224 6707	20.12	09 66 256 6612	22.16			09 66 324 6707	20.12
		09 66 224 7704	20.12	09 66 256 6613	22.16	09 66 313 6600	02.14	09 66 324 7704	20.12
09 66 213 6600	02.14	09 66 224 7705	20.12	09 66 256 6615	22.18	09 66 313 6601	02.14	09 66 324 7705	20.12
09 66 213 6601	02.14	09 66 224 7706	20.12	09 66 256 6616	22.18	09 66 313 6602	02.14	09 66 324 7706	20.12
09 66 213 6602	02.14	09 66 224 7707	20.12	09 66 256 6617	22.18	09 66 313 6603	02.14	09 66 324 7707	20.12
09 66 213 6603	02.14			09 66 256 7610	22.16	09 66 313 6603	02.14		
09 66 213 7600	02.14	09 66 228 6700	02.32	09 66 256 7611	22.16	09 66 313 7600	02.14	09 66 328 6700	02.32
09 66 213 7601	02.14	09 66 228 6701	02.32	09 66 256 7612	22.16	09 66 313 7601	02.14	09 66 328 6701	02.32
09 66 213 7602	02.14	09 66 228 6702	02.32	09 66 256 7613	22.16	09 66 313 7602	02.14	09 66 328 6702	02.32
09 66 213 7603	02.14	09 66 228 7700	02.32	09 66 256 7615	22.18	09 66 313 7603	02.14	09 66 328 7700	02.32
		09 66 228 7701	02.32	09 66 256 7616	22.18			09 66 328 7701	02.32
		09 66 228 7702	02.32	09 66 256 7617	22.18	09 66 314 6500	20.12	09 66 328 7702	02.32
09 66 214 6500	20.12					09 66 314 6501	20.12		
09 66 214 6501	20.12	09 66 251 6511	02.06	09 66 257 6610	22.16	09 66 314 6502	20.12	09 66 351 6511	02.06
09 66 214 6502	20.12	09 66 251 6512	02.06	09 66 257 6611	22.16	09 66 314 6503	20.12	09 66 351 6512	02.06
09 66 214 6503	20.12	09 66 251 6513	02.06	09 66 257 6612	22.16	09 66 314 6504	20.12	09 66 351 6513	02.06
09 66 214 6504	20.12	09 66 251 7511	02.06	09 66 257 6613	22.16	09 66 314 6505	20.12	09 66 351 7511	02.06
09 66 214 6505	20.12	09 66 251 7512	02.06	09 66 257 7610	22.16	09 66 314 6506	20.12	09 66 351 7512	02.06
09 66 214 6506	20.12	09 66 251 7513	02.06	09 66 257 7611	22.16	09 66 314 6507	20.12	09 66 351 7513	02.06
09 66 214 6507	20.12			09 66 257 7612	22.16	09 66 314 7500	20.12		
09 66 214 7500	20.12	09 66 252 6610	02.12	09 66 257 7613	22.16	09 66 314 7501	20.12	09 66 352 6610	02.12
09 66 214 7501	20.12	09 66 252 6611	02.12			09 66 314 7502	20.12	09 66 352 6611	02.12
09 66 214 7502	20.12	09 66 252 6612	02.12	09 66 262 6811	02.10	09 66 314 7503	20.12	09 66 352 6612	02.12
09 66 214 7503	20.12	09 66 252 6613	02.12	09 66 262 6812	02.10	09 66 314 7504	20.12	09 66 352 6613	02.12
09 66 214 7504	20.12	09 66 252 6615	02.18	09 66 262 6813	02.10	09 66 314 7505	20.12	09 66 352 6615	02.18
09 66 214 7505	20.12	09 66 252 6616	02.18	09 66 262 6815	02.16	09 66 314 7506	20.12	09 66 352 6616	02.18
09 66 214 7506	20.12	09 66 252 6617	02.18	09 66 262 6816	02.16	09 66 314 7507	20.12	09 66 352 6617	02.18
09 66 214 7507	20.12	09 66 252 7610	02.12	09 66 262 6817	02.16			09 66 352 7610	02.12
		09 66 252 7611	02.12	09 66 262 7811	02.10	09 66 315 6501	22.14	09 66 352 7611	02.12
09 66 215 6501	22.14	09 66 252 7612	02.12	09 66 262 7812	02.10	09 66 315 6502	22.14	09 66 352 7612	02.12
09 66 215 6502	22.14	09 66 252 7613	02.12	09 66 262 7813	02.10	09 66 315 6503	22.14	09 66 352 7613	02.12
09 66 215 6503	22.14	09 66 252 7615	02.18	09 66 262 7815	02.16	09 66 315 7501	22.14	09 66 352 7615	02.18
09 66 215 7501	22.14	09 66 252 7616	02.18	09 66 262 7816	02.16	09 66 315 7502	22.14	09 66 352 7616	02.18
09 66 215 7502	22.14	09 66 252 7617	02.18	09 66 262 7817	02.16	09 66 315 7503	22.14	09 66 352 7617	02.18
09 66 215 7503	22.14								
		09 66 253 6610	02.12			09 66 318 6500	02.32	09 66 353 6610	02.12
09 66 218 6500	02.32	09 66 253 6611	02.12	09 66 263 6811	02.10	09 66 318 6501	02.32	09 66 353 6611	02.12
09 66 218 6501	02.32	09 66 253 6612	02.12	09 66 263 6812	02.10	09 66 318 6502	02.32	09 66 353 6612	02.12
09 66 218 6502	02.32	09 66 253 6613	02.12	09 66 263 6813	02.10	09 66 318 6503	02.32	09 66 353 6613	02.12
09 66 218 7500	02.32	09 66 253 7610	02.12	09 66 263 7811	02.10	09 66 318 7500	02.32	09 66 353 7610	02.12
09 66 218 7501	02.32	09 66 253 7611	02.12	09 66 263 7812	02.10	09 66 318 7501	02.32	09 66 353 7611	02.12
09 66 218 7502	02.32	09 66 253 7612	02.12	09 66 263 7813	02.10	09 66 318 7502	02.32	09 66 353 7612	02.12
		09 66 253 7613	02.12					09 66 353 7613	02.12
09 66 221 6701	02.05			09 66 264 6715	20.10	09 66 321 6701	02.05		
09 66 221 6702	02.05	09 66 254 6511	20.10	09 66 264 6716	20.10	09 66 321 6702	02.05	09 66 354 6511	20.10
09 66 221 6703	02.05	09 66 254 6512	20.10	09 66 264 6717	20.10	09 66 321 6703	02.05	09 66 354 6512	20.10
09 66 221 7701	02.05	09 66 254 6513	20.10	09 66 264 7715	20.10	09 66 321 7701	02.05	09 66 354 6513	20.10
09 66 221 7702	02.05	09 66 254 6515	20.10	09 66 264 7716	20.10	09 66 321 7702	02.05	09 66 354 6515	20.10
09 66 221 7703	02.05	09 66 254 6516	20.10	09 66 264 7717	20.10	09 66 321 7703	02.05	09 66 354 6516	20.10

List of part numbers



Part No.	Page	Part No.	Page	Part No.	Page	Part No.	Page	Part No.	Page
09 66 354 6517	20.10	09 66 408 0001	02.32	09 66 422 6801	02.10	09 66 455 6511	22.14	09 66 514 6500	20.12
09 66 354 7511	20.10			09 66 422 6802	02.10	09 66 455 6512	22.14	09 66 514 6501	20.12
09 66 354 7512	20.10	09 66 411 6501	02.06	09 66 422 6803	02.10	09 66 455 6513	22.14	09 66 514 6502	20.12
09 66 354 7513	20.10	09 66 411 6502	02.06	09 66 422 7801	02.10	09 66 455 7511	22.14	09 66 514 6503	20.12
09 66 354 7515	20.10	09 66 411 6503	02.06	09 66 422 7802	02.10	09 66 455 7512	22.14	09 66 514 7500	20.12
09 66 354 7516	20.10	09 66 411 7501	02.06	09 66 422 7803	02.10	09 66 455 7513	22.14	09 66 514 7501	20.12
09 66 354 7517	20.10	09 66 411 7502	02.06					09 66 514 7502	20.12
		09 66 411 7503	02.06	09 66 423 6801	02.10	09 66 456 6610	22.16	09 66 514 7503	20.12
09 66 355 6511	22.14			09 66 423 6802	02.10	09 66 456 6611	22.16		
09 66 355 6512	22.14	09 66 412 6600	02.14	09 66 423 6803	02.10	09 66 456 6612	22.16	09 66 521 6701	02.05
09 66 355 6513	22.14	09 66 412 6601	02.14	09 66 423 7801	02.10	09 66 456 6613	22.16	09 66 521 6702	02.05
09 66 355 7511	22.14	09 66 412 6602	02.14	09 66 423 7802	02.10	09 66 456 6615	22.18	09 66 521 6703	02.05
09 66 355 7512	22.14	09 66 412 6603	02.14	09 66 423 7803	02.10	09 66 456 6616	22.18	09 66 521 7701	02.05
09 66 355 7513	22.14	09 66 412 7600	02.14			09 66 456 6617	22.18	09 66 521 7702	02.05
		09 66 412 7601	02.14	09 66 428 6700	02.32	09 66 456 7610	22.16	09 66 521 7703	02.05
09 66 356 6610	22.16	09 66 412 7602	02.14	09 66 428 6701	02.32	09 66 456 7611	22.16		
09 66 356 6611	22.16	09 66 412 7603	02.14	09 66 428 6702	02.32	09 66 456 7612	22.16	09 66 522 6801	02.10
09 66 356 6612	22.16			09 66 428 6703	02.32	09 66 456 7613	22.16	09 66 522 6802	02.10
09 66 356 6613	22.16	09 66 413 6600	02.14	09 66 428 7700	02.32	09 66 456 7615	22.18	09 66 522 6803	02.10
09 66 356 6615	22.18	09 66 413 6601	02.14	09 66 428 7701	02.32	09 66 456 7616	22.18	09 66 522 7801	02.10
09 66 356 6616	22.18	09 66 413 6602	02.14	09 66 428 7702	02.32	09 66 456 7617	22.18	09 66 522 7802	02.10
09 66 356 6617	22.18	09 66 413 6603	02.14					09 66 522 7803	02.10
09 66 356 7610	22.16	09 66 413 7600	02.14	09 66 451 6511	02.06	09 66 457 6610	22.16		
09 66 356 7611	22.16	09 66 413 7601	02.14	09 66 451 6512	02.06	09 66 457 6611	22.16	09 66 523 6801	02.10
09 66 356 7612	22.16	09 66 413 7602	02.14	09 66 451 6513	02.06	09 66 457 6612	22.16	09 66 523 6802	02.10
09 66 356 7613	22.16	09 66 413 7603	02.14	09 66 451 7511	02.06	09 66 457 6613	22.16	09 66 523 6803	02.10
09 66 356 7615	22.18			09 66 451 7512	02.06	09 66 457 7610	22.16	09 66 523 7801	02.10
09 66 356 7616	22.18	09 66 414 6500	20.12	09 66 451 7513	02.06	09 66 457 7611	22.16	09 66 523 7802	02.10
09 66 356 7617	22.18	09 66 414 6501	20.12	09 66 452 6610	02.12	09 66 457 7612	22.16	09 66 523 7803	02.10
		09 66 414 6502	20.12	09 66 452 6611	02.12	09 66 462 6811	02.10	09 66 552 6610	02.12
09 66 357 6610	22.16	09 66 414 6503	20.12	09 66 452 6612	02.12	09 66 462 6812	02.10	09 66 552 6611	02.12
09 66 357 6611	22.16	09 66 414 6504	20.12	09 66 452 6613	02.12	09 66 462 6813	02.10	09 66 552 6612	02.12
09 66 357 6612	22.16	09 66 414 6505	20.12	09 66 452 6615	02.18	09 66 462 6815	02.16	09 66 552 6613	02.12
09 66 357 6613	22.16	09 66 414 6506	20.12	09 66 452 6616	02.18	09 66 462 6816	02.16	09 66 552 6615	02.18
09 66 357 7610	22.16	09 66 414 6507	20.12	09 66 452 6617	02.18	09 66 462 6817	02.16	09 66 552 6616	02.18
09 66 357 7611	22.16	09 66 414 7500	20.12	09 66 452 7610	02.12	09 66 462 7811	02.10	09 66 552 6617	02.18
09 66 357 7612	22.16	09 66 414 7501	20.12	09 66 452 7611	02.12	09 66 462 7812	02.10	09 66 552 7610	02.12
09 66 357 7613	22.16	09 66 414 7502	20.12	09 66 452 7612	02.12	09 66 462 7813	02.10	09 66 552 7611	02.12
		09 66 414 7503	20.12	09 66 452 7613	02.12	09 66 462 7815	02.16	09 66 552 7612	02.12
09 66 362 6811	02.10	09 66 414 7504	20.12	09 66 452 7615	02.18	09 66 462 7816	02.16	09 66 552 7613	02.12
09 66 362 6812	02.10	09 66 414 7505	20.12	09 66 452 7616	02.18	09 66 462 7817	02.16	09 66 552 7615	02.18
09 66 362 6813	02.10	09 66 414 7506	20.12	09 66 452 7617	02.18			09 66 552 7616	02.18
09 66 362 6815	02.16	09 66 414 7507	20.12			09 66 463 6811	02.10	09 66 552 7617	02.18
09 66 362 6816	02.16			09 66 453 6610	02.12	09 66 463 6812	02.10		
09 66 362 6817	02.16	09 66 415 6501	22.14	09 66 453 6611	02.12	09 66 463 6813	02.10	09 66 554 6511	20.10
09 66 362 7811	02.10	09 66 415 6502	22.14	09 66 453 6612	02.12	09 66 463 7811	02.10	09 66 554 6512	20.10
09 66 362 7812	02.10	09 66 415 6503	22.14	09 66 453 6613	02.12	09 66 463 7812	02.10	09 66 554 6513	20.10
09 66 362 7813	02.10	09 66 415 7501	22.14	09 66 453 7610	02.12	09 66 463 7813	02.10	09 66 554 7511	20.10
09 66 362 7815	02.16	09 66 415 7502	22.14	09 66 453 7611	02.12			09 66 554 7512	20.10
09 66 362 7816	02.16	09 66 415 7503	22.14	09 66 453 7612	02.12	09 66 511 6501	02.06	09 66 554 7513	20.10
09 66 362 7817	02.16			09 66 453 7613	02.12	09 66 511 6502	02.06		
		09 66 418 6500	02.32			09 66 511 6503	02.06	09 66 562 6811	02.10
09 66 363 6811	02.10	09 66 418 6501	02.32	09 66 454 6511	20.10	09 66 511 7501	02.06	09 66 562 6812	02.10
09 66 363 6812	02.10	09 66 418 6502	02.32	09 66 454 6512	20.10	09 66 511 7502	02.06	09 66 562 6813	02.10
09 66 363 6813	02.10	09 66 418 7500	02.32	09 66 454 6513	20.10	09 66 511 7503	02.06	09 66 562 6815	02.16
09 66 363 7811	02.10	09 66 418 7501	02.32	09 66 454 6515	20.10			09 66 562 6816	02.16
09 66 363 7812	02.10	09 66 418 7502	02.32	09 66 454 6516	20.10	09 66 512 6600	02.14	09 66 562 6817	02.16
09 66 363 7813	02.10			09 66 454 6517	20.10	09 66 512 6601	02.14	09 66 562 7811	02.10
		09 66 421 6701	02.05	09 66 454 7511	20.10	09 66 512 6602	02.14	09 66 562 7812	02.10
09 66 364 6715	20.10	09 66 421 6702	02.05	09 66 454 7512	20.10	09 66 512 6603	02.14	09 66 562 7813	02.10
09 66 364 6716	20.10	09 66 421 6703	02.05	09 66 454 7513	20.10	09 66 512 7600	02.14	09 66 562 7815	02.16
09 66 364 6717	20.10	09 66 421 7701	02.05	09 66 454 7515	20.10	09 66 512 7601	02.14	09 66 562 7816	02.16
09 66 364 7715	20.10	09 66 421 7702	02.05	09 66 454 7516	20.10	09 66 512 7602	02.14	09 66 562 7817	02.16
09 66 364 7716	20.10	09 66 421 7703	02.05	09 66 454 7517	20.10	09 66 512 7603	02.14		
09 66 364 7717	20.10								

Part No.

List of part numbers



Part No.	Page	Part No.	Page	Part No.	Page	Part No.	Page	Part No.	Page
09 66 563 6811	02.10	09 67 000 8147	02.28	09 67 002 9001	06.23	09 67 002 9133	07.19	09 67 009 5615	02.34
09 66 563 6812	02.10	09 67 000 8148	02.28	09 67 002 9002	06.23	09 67 002 9134	07.19	09 67 009 5616	02.25
09 66 563 6813	02.10	09 67 000 8156	02.28	09 67 002 9003	06.23	09 67 002 9135	07.19	09 67 009 5654	02.04
09 66 563 7811	02.10	09 67 000 8157	02.28	09 67 002 9006	06.23	09 67 002 9136	07.19	09 67 009 5655	02.04
09 66 563 7812	02.10	09 67 000 8158	02.28	09 67 002 9007	06.23				
09 66 563 7813	02.10	09 67 000 8166	02.28	09 67 002 9008	06.25				
		09 67 000 8167	02.28	09 67 002 9009	06.25	09 67 009 0322	07.10	09 67 015 0322	07.10
		09 67 000 8168	02.28	09 67 002 9010	06.25	09 67 009 0323	07.10	09 67 015 0323	07.10
		09 67 000 8176	02.28	09 67 002 9011	06.25	09 67 009 0333	07.08	09 67 015 0333	07.08
09 67 000 3476	02.27	09 67 000 8177	02.28	09 67 002 9012	06.25	09 67 009 0334	07.09	09 67 015 0334	07.09
09 67 000 3476	04.22	09 67 000 8178	02.28	09 67 002 9013	06.25	09 67 009 0335	07.09	09 67 015 0335	07.09
09 67 000 3476	31.05	09 67 000 8236	02.30	09 67 002 9017	07.20	09 67 009 0336	07.08	09 67 015 0336	07.08
09 67 000 3576	02.27	09 67 000 8237	02.30	09 67 002 9018	07.20	09 67 009 0343	07.08	09 67 015 0343	07.08
09 67 000 3576	04.22	09 67 000 8238	02.30	09 67 002 9019	07.20	09 67 009 0344	07.09	09 67 015 0344	07.09
09 67 000 3576	31.05	09 67 000 8246	02.30	09 67 002 9020	07.20	09 67 009 0348	07.08	09 67 015 0348	07.08
09 67 000 3676	02.27	09 67 000 8247	02.30	09 67 002 9028	07.08	09 67 009 0349	07.09	09 67 015 0349	07.09
09 67 000 3676	04.22	09 67 000 8248	02.30	09 67 002 9029	07.08	09 67 009 0411	07.15	09 67 015 0411	07.15
09 67 000 5476	02.27	09 67 000 8256	02.30	09 67 002 9030	08.03	09 67 009 0413	07.15	09 67 015 0413	07.15
09 67 000 5476	04.22	09 67 000 8257	02.30	09 67 002 9031	07.10	09 67 009 0421	07.07	09 67 015 0421	07.07
09 67 000 5476	31.05	09 67 000 8258	02.30	09 67 002 9032	07.10	09 67 009 0422	07.07	09 67 015 0422	07.07
09 67 000 5576	02.27	09 67 000 8266	02.30	09 67 002 9032	07.10	09 67 009 0423	07.07	09 67 015 0423	07.07
09 67 000 5576	04.22	09 67 000 8267	02.30	09 67 002 9040	07.10	09 67 009 0424	07.04	09 67 015 0424	07.04
09 67 000 5576	31.05	09 67 000 8268	02.30	09 67 002 9041	07.10	09 67 009 0425	07.04	09 67 015 0425	07.04
09 67 000 5676	02.27	09 67 000 8276	02.30	09 67 002 9042	07.10	09 67 009 0426	07.04	09 67 015 0426	07.04
09 67 000 5676	04.22	09 67 000 8277	02.30	09 67 002 9044	07.10	09 67 009 0427	07.04	09 67 015 0427	07.04
09 67 000 7136	02.28	09 67 000 8278	02.30	09 67 002 9045	07.10	09 67 009 0430	07.04	09 67 015 0430	07.04
09 67 000 7137	02.28	09 67 000 8476	02.27	09 67 002 9050	06.23	09 67 009 0431	07.04	09 67 015 0431	07.04
09 67 000 7138	02.28	09 67 000 8476	31.05	09 67 002 9051	06.23	09 67 009 0434	07.04	09 67 015 0434	07.04
09 67 000 7146	02.28	09 67 000 8476	04.22	09 67 002 9052	06.23	09 67 009 0435	07.04	09 67 015 0435	07.04
09 67 000 7147	02.28	09 67 000 8576	02.27	09 67 002 9055	06.23	09 67 009 0436	06.24	09 67 015 0436	06.24
09 67 000 7148	02.28	09 67 000 8576	04.22	09 67 002 9056	06.23	09 67 009 0437	06.24	09 67 015 0437	06.24
09 67 000 7156	02.28	09 67 000 8576	31.05	09 67 002 9057	06.23	09 67 009 0438	06.22	09 67 015 0438	06.22
09 67 000 7157	02.28	09 67 000 8676	02.27	09 67 002 9060	06.23	09 67 009 0439	06.22	09 67 015 0439	06.22
09 67 000 7158	02.28	09 67 000 8676	04.22	09 67 002 9061	06.23	09 67 009 0442	07.07	09 67 015 0442	07.07
09 67 000 7166	02.28	09 67 000 8907	07.17	09 67 002 9062	06.23	09 67 009 0443	07.07	09 67 015 0443	07.07
09 67 000 7167	02.28	09 67 000 9914	07.17	09 67 002 9065	06.23	09 67 009 0452	07.15	09 67 015 0452	07.15
09 67 000 7168	02.28	09 67 000 9915	07.17	09 67 002 9066	06.23	09 67 009 0453	07.15	09 67 015 0453	07.15
09 67 000 7176	02.28	09 67 000 9916	07.17	09 67 002 9067	06.23	09 67 009 0454	07.15	09 67 015 0454	07.15
09 67 000 7177	02.28	09 67 000 9917	07.17	09 67 002 9075	07.05	09 67 009 0462	07.05	09 67 015 0462	07.05
09 67 000 7178	02.28	09 67 000 9918	07.17	09 67 002 9077	07.05	09 67 009 0463	07.05	09 67 015 0463	07.05
09 67 000 7236	02.30	09 67 000 9918	07.17	09 67 002 9081	07.05	09 67 009 0464	07.05	09 67 015 0464	07.05
09 67 000 7237	02.30	09 67 000 9922	08.03	09 67 002 9090	07.09	09 67 009 0465	07.05	09 67 015 0465	07.05
09 67 000 7238	02.30	09 67 000 9924	08.03	09 67 002 9091	07.09	09 67 009 0511	07.15	09 67 015 0511	07.15
09 67 000 7246	02.30	09 67 000 9925	07.07	09 67 002 9092	07.08	09 67 009 0513	07.15	09 67 015 0513	07.15
09 67 000 7247	02.30	09 67 000 9930	07.07	09 67 002 9092	07.08	09 67 009 0538	06.22	09 67 015 0538	06.22
09 67 000 7248	02.30	09 67 000 9971	07.06	09 67 002 9094	07.08	09 67 009 0539	06.22	09 67 015 0539	06.22
09 67 000 7256	02.30	09 67 000 9972	08.02	09 67 002 9101	07.08	09 67 009 0571	07.06	09 67 015 0571	07.06
09 67 000 7257	02.30	09 67 000 9972	08.02	09 67 002 9102	07.05	09 67 009 0573	07.06	09 67 015 0573	07.06
09 67 000 7258	02.30	09 67 000 9973	08.03	09 67 002 9103	07.05	09 67 009 0611	08.04	09 67 015 0611	08.04
09 67 000 7266	02.30	09 67 000 9974	08.02	09 67 002 9104	07.05	09 67 009 0612	08.04	09 67 015 0612	08.04
09 67 000 7267	02.30			09 67 002 9105	07.05	09 67 009 0613	08.04	09 67 015 0613	08.04
09 67 000 7268	02.30	09 67 001 9928	08.03	09 67 002 9106	07.05	09 67 009 0614	08.05	09 67 015 0614	08.05
09 67 000 7276	02.30	09 67 001 9941	08.02	09 67 002 9120	08.03	09 67 009 0614	08.05	09 67 015 0614	08.05
09 67 000 7276	02.30	09 67 001 9941	08.02	09 67 002 9121 xx1	07.19	09 67 009 0615	08.05	09 67 015 0615	08.05
09 67 000 7277	02.30	09 67 001 9954	08.02	09 67 002 9121 xx2	07.19	09 67 009 0711	08.04	09 67 015 0711	08.04
09 67 000 7278	02.30	09 67 001 9957	08.02	09 67 002 9121 xx3	07.19	09 67 009 0712	08.04	09 67 015 0712	08.04
09 67 000 7476	02.27	09 67 001 9965	07.06	09 67 002 9121 xx4	07.19	09 67 009 0713	08.04	09 67 015 0713	08.04
09 67 000 7476	31.05	09 67 001 9968	07.05	09 67 002 9122 xx1	07.19	09 67 009 0714	08.05	09 67 015 0714	08.05
09 67 000 7476	04.22	09 67 001 9969	08.03	09 67 002 9122 xx2	07.19	09 67 009 0715	08.05	09 67 015 0715	08.05
09 67 000 7576	02.27	09 67 001 9970	08.03	09 67 002 9122 xx3	07.19	09 67 009 4701	02.26	09 67 015 4701	02.26
09 67 000 7576	31.05	09 67 001 9971	07.17	09 67 002 9122 xx4	07.19	09 67 009 4704	02.34	09 67 015 4704	02.34
09 67 000 7576	04.22	09 67 001 9972	07.17	09 67 002 9123	07.19	09 67 009 4707	02.25	09 67 015 4707	02.25
09 67 000 7676	02.27	09 67 001 9973	07.17	09 67 002 9124	07.19	09 67 009 4715	02.34	09 67 015 4715	02.34
09 67 000 7676	04.22	09 67 001 9974	08.02	09 67 002 9125	07.19	09 67 009 4716	02.25	09 67 015 4716	02.25
09 67 000 8136	02.28	09 67 001 9976	08.02	09 67 002 9126	07.19	09 67 009 4754	02.04	09 67 015 4754	02.04
09 67 000 8137	02.28	09 67 001 9977	07.06	09 67 002 9129	07.19	09 67 009 4755	02.04	09 67 015 4755	02.04
09 67 000 8138	02.28	09 67 001 9978	07.06	09 67 002 9130	07.19	09 67 009 5601	02.26	09 67 015 5601	02.26
09 67 000 8146	02.28	09 67 001 9985	08.03	09 67 002 9131	07.19	09 67 009 5604	02.34	09 67 015 5604	02.34
		09 67 001 9997	07.08	09 67 002 9132	07.19	09 67 009 5607	02.25	09 67 015 5607	02.25

List of part numbers



Part No.	Page	Part No.	Page	Part No.	Page	Part No.	Page	Part No.	Page
09 67 015 5615	02.34	09 67 025 5615	02.34	09 67 050 0322	07.10	09 67 237 4704	02.34	09 67 609 6775	06.16
09 67 015 5616	02.25	09 67 025 5616	02.25	09 67 050 0323	07.10	09 67 237 4715	02.34	09 67 609 7615	06.10
09 67 015 5654	02.04	09 67 025 5654	02.04	09 67 050 0333	07.08	09 67 237 5604	02.34	09 67 609 7658	06.20
09 67 015 5655	02.04	09 67 025 5655	02.04	09 67 050 0334	07.09	09 67 237 5615	02.34	09 67 609 7675	06.16
				09 67 050 0335	07.09			09 67 609 8715	06.10
				09 67 050 0336	07.08	09 67 250 4704	02.34	09 67 609 8758	06.20
09 67 025 0322	07.10	09 67 037 0322	07.10	09 67 050 0343	07.08	09 67 250 4715	02.34	09 67 609 8775	06.16
09 67 025 0323	07.10	09 67 037 0323	07.10	09 67 050 0344	07.09	09 67 250 5604	02.34	09 67 609 9615	06.10
09 67 025 0333	07.08	09 67 037 0333	07.08	09 67 050 0348	07.08	09 67 250 5615	02.34	09 67 609 9658	06.20
09 67 025 0334	07.09	09 67 037 0334	07.09	09 67 050 0349	07.09			09 67 609 9675	06.16
09 67 025 0335	07.09	09 67 037 0335	07.09	09 67 050 0411	07.15	09 67 409 4715	06.04		
09 67 025 0336	07.08	09 67 037 0336	07.08	09 67 050 0413	07.15	09 67 409 5615	06.04	09 67 615 6715	06.10
09 67 025 0343	07.08	09 67 037 0343	07.08	09 67 050 0423	07.07			09 67 615 6758	06.20
09 67 025 0344	07.09	09 67 037 0344	07.09	09 67 050 0424	07.04	09 67 415 4715	06.04	09 67 615 6775	06.16
09 67 025 0348	07.08	09 67 037 0348	07.08	09 67 050 0426	07.04	09 67 415 5615	06.04	09 67 615 7615	06.10
09 67 025 0349	07.09	09 67 037 0349	07.09	09 67 050 0438	06.22			09 67 615 7658	06.20
09 67 025 0411	07.15	09 67 037 0411	07.15	09 67 050 0439	06.22	09 67 425 4715	06.04	09 67 615 7675	06.16
09 67 025 0413	07.15	09 67 037 0413	07.15	09 67 050 0442	07.07	09 67 425 5615	06.04	09 67 615 8715	06.10
09 67 025 0421	07.07	09 67 037 0421	07.07	09 67 050 0443	07.07			09 67 615 8758	06.20
09 67 025 0422	07.07	09 67 037 0422	07.07	09 67 050 0452	07.15	09 67 437 4715	06.04	09 67 615 8775	06.16
09 67 025 0423	07.07	09 67 037 0423	07.07	09 67 050 0453	07.15	09 67 437 5615	06.04	09 67 615 9615	06.10
09 67 025 0424	07.04	09 67 037 0424	07.04	09 67 050 0511	07.15			09 67 615 9658	06.20
09 67 025 0425	07.04	09 67 037 0425	07.04	09 67 050 0513	07.15	09 67 450 4715	06.04	09 67 615 9675	06.16
09 67 025 0426	07.04	09 67 037 0426	07.04	09 67 050 0538	06.22	09 67 450 5615	06.04		
09 67 025 0427	07.04	09 67 037 0427	07.04	09 67 050 0539	06.22			09 67 625 6715	06.10
09 67 025 0430	07.04	09 67 037 0434	07.04	09 67 050 0571	07.06			09 67 625 6758	06.20
09 67 025 0431	07.04	09 67 037 0435	07.04	09 67 050 0573	07.06	09 67 509 6715	06.06	09 67 625 6775	06.16
09 67 025 0434	07.04	09 67 037 0438	06.22	09 67 050 0612	08.04	09 67 509 6758	06.18	09 67 625 7615	06.10
09 67 025 0435	07.04	09 67 037 0439	06.22	09 67 050 0613	08.04	09 67 509 6775	06.14	09 67 625 7658	06.20
09 67 025 0436	06.24	09 67 037 0442	07.07	09 67 050 0614	08.05	09 67 509 7615	06.06	09 67 625 7675	06.16
09 67 025 0437	06.24	09 67 037 0443	07.07	09 67 050 0615	08.05	09 67 509 7658	06.18	09 67 625 7675	06.16
09 67 025 0438	06.22	09 67 037 0452	07.15	09 67 050 0712	08.04	09 67 509 7675	06.14	09 67 625 8715	06.10
09 67 025 0439	06.22	09 67 037 0453	07.15	09 67 050 0713	08.04	09 67 509 8715	06.06	09 67 625 8758	06.20
09 67 025 0442	07.07	09 67 037 0462	07.05	09 67 050 0714	08.05	09 67 509 8758	06.18	09 67 625 8775	06.16
09 67 025 0443	07.07	09 67 037 0463	07.05	09 67 050 0715	08.05	09 67 509 8775	06.14	09 67 625 9615	06.10
09 67 025 0452	07.15	09 67 037 0464	07.05	09 67 050 0715	08.05	09 67 509 9615	06.06	09 67 625 9658	06.20
09 67 025 0453	07.15	09 67 037 0465	07.05	09 67 050 4701	02.26	09 67 509 9658	06.18	09 67 625 9675	06.16
09 67 025 0462	07.05	09 67 037 0511	07.15	09 67 050 4704	02.34	09 67 509 9675	06.14		
09 67 025 0463	07.05	09 67 037 0513	07.15	09 67 050 4707	02.25			09 67 637 6715	06.10
09 67 025 0464	07.05	09 67 037 0513	07.15	09 67 050 4715	02.34	09 67 515 6715	06.06	09 67 637 6758	06.20
09 67 025 0464	07.05	09 67 037 0538	06.22	09 67 050 4716	02.25	09 67 515 6758	06.18	09 67 637 6775	06.16
09 67 025 0465	07.05	09 67 037 0539	06.22	09 67 050 4716	02.25	09 67 515 6775	06.14	09 67 637 7615	06.10
09 67 025 0511	07.15	09 67 037 0571	07.06	09 67 050 4754	02.04	09 67 515 7615	06.06	09 67 637 7658	06.20
09 67 025 0513	07.15	09 67 037 0571	07.06	09 67 050 4755	02.04	09 67 515 7615	06.06	09 67 637 7675	06.16
09 67 025 0538	06.22	09 67 037 0611	08.04	09 67 050 4755	02.04	09 67 515 7658	06.18	09 67 637 8715	06.10
09 67 025 0539	06.22	09 67 037 0612	08.04	09 67 050 5601	02.26	09 67 515 7675	06.14	09 67 637 8715	06.10
09 67 025 0571	07.06	09 67 037 0612	08.04	09 67 050 5604	02.34	09 67 515 8715	06.06	09 67 637 8758	06.20
09 67 025 0573	07.06	09 67 037 0613	08.04	09 67 050 5607	02.25	09 67 515 8715	06.06	09 67 637 8775	06.16
09 67 025 0611	08.04	09 67 037 0613	08.04	09 67 050 5615	02.34	09 67 515 8758	06.18	09 67 637 9615	06.10
09 67 025 0612	08.04	09 67 037 0614	08.05	09 67 050 5615	02.34	09 67 515 8775	06.14	09 67 637 9658	06.20
09 67 025 0613	08.04	09 67 037 0615	08.05	09 67 050 5616	02.25	09 67 515 9615	06.06	09 67 637 9675	06.16
09 67 025 0614	08.05	09 67 037 0615	08.05	09 67 050 5654	02.04	09 67 515 9658	06.18		
09 67 025 0615	08.05	09 67 037 0711	08.04	09 67 050 5655	02.04	09 67 515 9675	06.14		
09 67 025 0615	08.05	09 67 037 0712	08.04						
09 67 025 0711	08.04	09 67 037 0713	08.04	09 67 209 4704	02.34			09 67 650 6715	06.10
09 67 025 0712	08.04	09 67 037 0714	08.05	09 67 209 4715	02.34	09 67 525 6715	06.06	09 67 650 6758	06.20
09 67 025 0713	08.04	09 67 037 0715	08.05	09 67 209 5604	02.34	09 67 525 6758	06.18	09 67 650 6775	06.16
09 67 025 0714	08.05	09 67 037 4704	02.34	09 67 209 5615	02.34	09 67 525 6775	06.14	09 67 650 7615	06.10
09 67 025 0715	08.05	09 67 037 4707	02.25			09 67 525 7615	06.06	09 67 650 7658	06.20
09 67 025 4701	02.26	09 67 037 4715	02.34			09 67 525 7658	06.18	09 67 650 7675	06.16
09 67 025 4704	02.34	09 67 037 4716	02.25	09 67 215 4704	02.34	09 67 525 7675	06.14	09 67 650 8715	06.10
09 67 025 4707	02.25	09 67 037 4754	02.04	09 67 215 4715	02.34	09 67 525 8715	06.06	09 67 650 8758	06.20
09 67 025 4715	02.34	09 67 037 4755	02.04	09 67 215 5604	02.34	09 67 525 8758	06.18	09 67 650 8775	06.16
09 67 025 4716	02.25	09 67 037 5601	02.26	09 67 215 5615	02.34	09 67 525 8775	06.14	09 67 650 9615	06.10
09 67 025 4754	02.04	09 67 037 5604	02.34			09 67 525 9615	06.06	09 67 650 9658	06.20
09 67 025 4755	02.04	09 67 037 5607	02.25			09 67 525 9658	06.18	09 67 650 9675	06.16
09 67 025 5601	02.26	09 67 037 5615	02.34	09 67 225 4704	02.34	09 67 525 9675	06.14		
09 67 025 5604	02.34	09 67 037 5616	02.25	09 67 225 4715	02.34			09 67 709 6715	06.08
09 67 025 5607	02.25	09 67 037 5654	02.04	09 67 225 5604	02.34	09 67 609 6715	06.10	09 67 709 7615	06.08
		09 67 037 5655	02.04	09 67 225 5615	02.34	09 67 609 6758	06.20		

Part No.

List of part numbers



Part No.	Page	Part No.	Page	Part No.	Page	Part No.	Page	Part No.	Page
09 67 709 8715	06.08	09 68 353 5611	02.20	09 69 182 2550	04.23	09 69 281 7420	04.24	09 69 401 5136	04.11
09 67 709 9615	06.08	09 68 353 5612	02.20	09 69 182 5140	04.26	09 69 281 7421	04.24	09 69 401 5214	04.07
		09 68 353 5613	02.20	09 69 182 5230	04.26	09 69 281 7422	04.24	09 69 401 5253	04.08
09 67 715 6715	06.08	09 68 353 7611	02.20	09 69 182 5232	04.26	09 69 281 7423	04.24	09 69 401 5272	04.07
09 67 715 7615	06.08	09 68 353 7612	02.20	09 69 182 5233	04.26	09 69 281 7821	04.24	09 69 401 7136	04.11
09 67 715 8715	06.08	09 68 353 7613	02.20	09 69 182 5420	04.24	09 69 281 7823	04.24	09 69 401 7214	04.07
09 67 715 9615	06.08			09 69 182 5421	04.24			09 69 401 7253	04.08
		09 68 363 5811	02.20	09 69 182 5422	04.24	09 69 282 2550	04.23	09 69 401 7272	04.07
09 67 725 6715	06.08	09 68 363 5812	02.20	09 69 182 5423	04.24	09 69 282 5140	04.26		
09 67 725 7615	06.08	09 68 363 5813	02.20	09 69 182 5821	04.24	09 69 282 5230	04.26	09 69 402 0214	04.17
09 67 725 8715	06.08	09 68 363 7811	02.20	09 69 182 5823	04.24	09 69 282 5232	04.26	09 69 402 0253	04.18
09 67 725 9615	06.08	09 68 363 7812	02.20	09 69 182 7140	04.26	09 69 282 5233	04.26	09 69 402 0272	04.17
		09 68 363 7813	02.20	09 69 182 7230	04.26	09 69 282 5420	04.24		
09 67 809 6715	06.12			09 69 182 7232	04.26	09 69 282 5421	04.24	09 69 410 0077	04.14
09 67 809 7615	06.12	09 68 453 5611	02.20	09 69 182 7233	04.26	09 69 282 5422	04.24	09 69 410 0088	04.14
09 67 809 8715	06.12	09 68 453 5612	02.20	09 69 182 7420	04.24	09 69 282 5423	04.24		
09 67 809 9615	06.12	09 68 453 5613	02.20	09 69 182 7421	04.24	09 69 282 5821	04.24	09 69 411 5136	04.11
		09 68 453 5613	02.20	09 69 182 7422	04.24	09 69 282 5823	04.24	09 69 411 5214	04.07
09 67 815 6715	06.12	09 68 453 7611	02.20	09 69 182 7423	04.24	09 69 282 7140	04.26	09 69 411 5253	04.08
09 67 815 7615	06.12	09 68 453 7612	02.20	09 69 182 7821	04.24	09 69 282 7230	04.26	09 69 411 5272	04.07
09 67 815 8715	06.12	09 68 453 7613	02.20	09 69 182 7823	04.24	09 69 282 7232	04.26	09 69 411 7136	04.11
09 67 815 9615	06.12					09 69 282 7233	04.26	09 69 411 7214	04.07
		09 68 463 5811	02.20	09 69 187 0060	04.29	09 69 282 7420	04.24	09 69 411 7253	04.08
09 67 825 6715	06.12	09 68 463 5812	02.20	09 69 187 0061	04.29	09 69 282 7421	04.24	09 69 411 7272	04.07
09 67 825 7615	06.12	09 68 463 5813	02.20	09 69 187 0062	04.29	09 69 282 7422	04.24		
09 67 825 8715	06.12	09 68 463 7811	02.20	09 69 187 0062	04.29	09 69 282 7423	04.24	09 69 412 0214	04.17
09 67 825 9615	06.12	09 68 463 7812	02.20	09 69 187 0063	04.29	09 69 282 7821	04.24	09 69 412 0253	04.18
		09 68 463 7813	02.20			09 69 282 7823	04.24	09 69 412 0272	04.17
				09 69 200 0033	04.14				
09 67 837 6715	06.12			09 69 200 0633	04.16	09 69 287 0060	04.29		
09 67 837 7615	06.12					09 69 287 0061	04.29	09 69 501 5247	04.12
09 67 837 8715	06.12	09 69 100 0022	04.15	09 69 201 5072	04.07	09 69 287 0062	04.29	09 69 501 5364	04.13
09 67 837 9615	06.12	09 69 100 0522	04.14	09 69 201 5111	04.10	09 69 287 0063	04.29	09 69 501 5432	04.13
				09 69 201 7072	04.07			09 69 501 7247	04.12
09 67 850 6715	06.12	09 69 101 5051	04.10	09 69 201 7111	04.10	09 69 300 0055	04.14	09 69 501 7364	04.13
09 67 850 7615	06.12	09 69 101 7051	04.10					09 69 501 7432	04.13
09 67 850 8715	06.12			09 69 202 0072	04.17	09 69 301 5094	04.08		
09 67 850 9615	06.12			09 69 202 0111	04.19	09 69 301 5133	04.08	09 69 502 0364	04.20
		09 69 110 0022	04.15			09 69 301 5172	04.07		
		09 69 110 0522	04.14	09 69 210 0033	04.14	09 69 301 5211	04.10	09 69 511 5247	04.12
09 68 153 5611	02.20			09 69 210 0633	04.16	09 69 301 5211	04.10	09 69 511 5364	04.13
09 68 153 5612	02.20	09 69 111 5051	04.10			09 69 301 7094	04.08	09 69 511 5432	04.13
09 68 153 5613	02.20	09 69 111 7051	04.10	09 69 211 5072	04.07	09 69 301 7133	04.08	09 69 511 7247	04.12
09 68 153 7611	02.20			09 69 211 5111	04.10	09 69 301 7172	04.07	09 69 511 7364	04.13
09 68 153 7612	02.20			09 69 211 7072	04.07	09 69 301 7211	04.10	09 69 511 7432	04.13
09 68 153 7613	02.20	09 69 181 2550	04.23	09 69 211 7111	04.10				
		09 69 181 5140	04.26			09 69 302 0133	04.18		
		09 69 181 5141	04.26			09 69 302 0172	04.17		
09 68 163 5811	02.20	09 69 181 5143	04.26	09 69 212 0072	04.17	09 69 302 0211	04.19	09 69 512 0364	04.20
09 68 163 5812	02.20	09 69 181 5230	04.26	09 69 212 0111	04.19				
09 68 163 5813	02.20	09 69 181 5233	04.26			09 69 310 0055	04.14	09 69 581 2550	04.23
09 68 163 7811	02.20	09 69 181 5420	04.24	09 69 281 2550	04.23				
09 68 163 7812	02.20	09 69 181 5421	04.24	09 69 281 5140	04.26	09 69 311 5094	04.08	09 69 681 2550	04.23
09 68 163 7813	02.20	09 69 181 5422	04.24	09 69 281 5141	04.26	09 69 311 5133	04.08		
		09 69 181 5423	04.24	09 69 281 5143	04.26	09 69 311 5172	04.07		
09 68 253 5611	02.20	09 69 181 5821	04.24	09 69 281 5230	04.26	09 69 311 5211	04.10	09 89 040 0000	30.04
09 68 253 5612	02.20	09 69 181 5823	04.24	09 69 281 5233	04.26	09 69 311 5211	04.10		
09 68 253 5613	02.20	09 69 181 7140	04.26	09 69 281 5420	04.24	09 69 311 7094	04.08		
09 68 253 7611	02.20	09 69 181 7141	04.26	09 69 281 5421	04.24	09 69 311 7133	04.08		
09 68 253 7612	02.20	09 69 181 7143	04.26	09 69 281 5422	04.24	09 69 311 7172	04.07		
09 68 253 7613	02.20	09 69 181 7230	04.26	09 69 281 5423	04.24	09 69 311 7211	04.10	09 98 000 3004	31.07
		09 69 181 7233	04.26	09 69 281 5821	04.24			09 98 000 3005	31.07
09 68 263 5811	02.20	09 69 181 7420	04.24	09 69 281 5823	04.24	09 69 312 0133	04.18	09 98 000 3006	31.07
09 68 263 5812	02.20	09 69 181 7421	04.24	09 69 281 7140	04.26	09 69 312 0172	04.17	09 98 000 3007	31.07
09 68 263 5813	02.20	09 69 181 7422	04.24	09 69 281 7141	04.26	09 69 312 0211	04.19	09 98 000 3008	31.07
09 68 263 7811	02.20	09 69 181 7423	04.24	09 69 281 7143	04.26			09 98 000 3009	31.07
09 68 263 7812	02.20	09 69 181 7821	04.24	09 69 281 7230	04.26	09 69 400 0077	04.14	09 98 000 3012	31.07
09 68 263 7813	02.20	09 69 181 7823	04.24	09 69 281 7233	04.26	09 69 400 0088	04.14	09 98 000 5000	31.06

List of part numbers



Part No.	Page	Part No.	Page	Part No.	Page	Part No.	Page	Part No.	Page
09 99 000 0114	32.04	09 99 000 0508	31.09	33 18 243 0500 055	40.10	33 60 212 1000 106	40.04	60 02 068 5120	01.05
09 99 000 0114	32.05	09 99 000 0509	31.08	33 18 243 0500 060	40.10	33 60 212 1500 107	40.04	60 02 068 5120	22.06
09 99 000 0114	32.06	09 99 000 0510	30.12	33 18 243 0500 065	40.10	33 60 212 2000 108	40.04	60 02 068 5141	01.07
09 99 000 0115	32.06	09 99 000 0511	31.10	33 18 243 0800 066	40.10			60 02 068 5150	01.07
09 99 000 0116	32.04	09 99 000 0512	31.10	33 18 243 1000 057	40.10	33 60 213 1000 103	40.04	60 02 068 5322	20.06
09 99 000 0116	32.05	09 99 000 0513	31.04	33 18 243 1000 062	40.10	33 60 213 2000 104	40.04		
09 99 000 0116	32.06	09 99 000 0514	30.12	33 18 243 1000 067	40.10	33 60 213 5000 105	40.04	60 02 100 5141	01.07
09 99 000 0130	32.06	09 99 000 0515	31.08	33 18 243 1500 068	40.10			60 02 100 5150	01.07
09 99 000 0131	32.06	09 99 000 0516	30.12	33 18 243 1500 069	40.10				
09 99 000 0133	09.16	09 99 000 0518	31.09			33 60 214 5000 088	40.04		
09 99 000 0133	09.20	09 99 000 0519	31.08			33 60 214 5000 102	40.04	60 03 ... 5200	32.02
09 99 000 0133	09.23	09 99 000 0519	31.09	33 27 243 0500 001	00.08			60 03 ... 5205	32.02
09 99 000 0133	22.32	09 99 000 0520	30.12	33 27 243 0500 001	40.02	33 60 223 1000 181	40.05	60 03 ... 5210	32.02
09 99 000 0134	32.06	09 99 000 0521	31.08	33 27 243 0500 006	00.08	33 60 223 1000 187	40.05	60 03 ... 5215	32.02
09 99 000 0135	32.05	09 99 000 0522	31.08	33 27 243 0500 006	40.02	33 60 223 1000 192	40.05	60 03 ... 5220	32.02
09 99 000 0149	32.05	09 99 000 0523	30.10	33 27 243 0500 015	00.08	33 60 223 1500 182	40.05		
09 99 000 0149	32.06	09 99 000 0526	30.12	33 27 243 0500 015	40.02	33 60 223 1500 188	40.05	60 03 020 0255	01.16
09 99 000 0150	32.06	09 99 000 0531	31.05	33 27 243 1000 002	00.08	33 60 223 1500 193	40.05	60 03 020 0555	01.17
09 99 000 0158	31.04	09 99 000 0531	31.08	33 27 243 1000 002	40.02	33 60 223 2000 183	40.05	60 03 020 5200	01.09
09 99 000 0169	31.04	09 99 000 0533	31.10	33 27 243 1000 007	00.08	33 60 223 2000 189	40.05	60 03 020 5210	01.09
09 99 000 0171	31.12	09 99 000 0534	30.12	33 27 243 1000 007	40.02	33 60 223 2000 194	40.05	60 03 020 5220	01.09
09 99 000 0171	31.04	09 99 000 0535	31.04	33 27 243 1000 016	00.08	33 60 223 5000 184	40.05		
09 99 000 0175	31.04	09 99 000 0540	30.12	33 27 243 1000 016	40.02	33 60 223 5000 190	40.05	60 03 026 0255	01.16
09 99 000 0179	32.04	09 99 000 0550	30.12	33 27 243 1000 016	40.02	33 60 223 5000 195	40.05	60 03 026 0555	01.17
09 99 000 0179	32.05	09 99 000 0560	30.12	33 27 243 2000 003	00.08			60 03 026 5200	01.09
09 99 000 0179	32.06	09 99 000 0564	30.12	33 27 243 2000 003	40.02			60 03 026 5220	01.09
09 99 000 0180	32.04	09 99 000 0597	31.04	33 27 243 2000 008	00.08	33 60 224 5000 180	40.05		
09 99 000 0180	32.05	09 99 000 0600	30.10	33 27 243 2000 008	40.02	33 60 224 5000 186	40.05	60 03 036 0255	01.16
09 99 000 0180	32.06	09 99 000 0710	30.11	33 27 243 2000 017	00.08	33 60 224 5000 191	40.05		
09 99 000 0197	30.09	09 99 000 0714	30.11	33 27 243 2000 017	40.02				
09 99 000 0201	30.09	09 99 000 0716	30.11					60 03 050 0143	01.16
09 99 000 0215	07.06	09 99 000 0720	30.11					60 03 050 0255	01.16
09 99 000 0216	07.06	09 99 000 0726	30.11	33 56 212 0050 028	40.08	33 66 213 1000 059	40.09	60 03 050 0555	01.17
09 99 000 0218	30.12	09 99 000 0734	30.11	33 56 212 0050 032	40.08	33 66 213 1500 060	40.09	60 03 050 5200	01.09
09 99 000 0220	30.12	09 99 000 0740	30.11	33 56 212 0100 033	40.08	33 66 213 2000 061	40.09	60 03 050 5210	01.09
09 99 000 0233	31.13	09 99 000 0750	30.11	33 56 212 0500 029	40.08	33 66 213 5000 062	40.09	60 03 050 5220	01.09
09 99 000 0235	31.13	09 99 000 0760	30.11	33 56 212 0500 034	40.08				
09 99 000 0236	31.13	09 99 000 0764	30.11	33 56 212 1000 027	40.08	33 66 214 5000 058	40.09	60 03 068 0143	01.16
09 99 000 0237	31.13			33 56 212 1000 030	40.08			60 03 068 0145	01.16
09 99 000 0246	31.04	09 99 600 0201	32.05	33 56 212 1000 035	40.08			60 03 068 0255	01.16
09 99 000 0253	31.04	09 99 600 0709	30.10	33 56 212 1000 031	40.08			60 03 068 0555	01.17
09 99 000 0255	30.09	09 99 600 0715	30.10	33 56 212 2000 031	40.08			60 03 068 0655	01.17
09 99 000 0256	30.12	09 99 600 0725	30.10	33 56 212 2000 036	40.08			60 03 068 5205	01.09
09 99 000 0282	30.09					60 01 000 9013	01.20	60 03 068 5215	01.09
09 99 000 0406	30.12			33 56 213 0500 023	40.08	60 01 000 9018	01.20		
09 99 000 0410	30.12	27 11 122 2001	00.07	33 56 213 1000 002	40.08	60 01 000 9019	01.20	60 03 100 0143	01.16
09 99 000 0414	30.12			33 56 213 1000 024	40.08	60 01 000 9020	01.20	60 03 100 5210	01.09
09 99 000 0416	30.12			33 56 213 1500 022	40.08	60 01 000 9021	01.20		
09 99 000 0420	30.12	27 21 121 8000	00.07	33 56 213 2000 016	40.08	60 01 000 9030	01.20		
09 99 000 0426	30.12	27 21 121 8002	00.07	33 56 213 2000 025	40.08			60 04 050 5343	01.08
09 99 000 0434	30.12	27 21 121 8004	00.07	33 56 213 5000 026	40.08	60 01 020 5102	01.04	60 04 050 5344	01.08
09 99 000 0440	30.12	27 21 121 8005	00.07			60 01 020 5132	01.06		
09 99 000 0450	30.12	27 21 121 8006	00.07	33 56 221 0010 001	40.09	60 01 020 5140	01.06	60 04 068 5343	01.08
09 99 000 0460	30.12	27 21 121 8010	00.07	33 56 221 0020 001	40.09			60 04 068 5344	01.08
09 99 000 0464	30.12			33 56 221 0050 001	40.09				
09 99 000 0501	31.05					60 01 026 5102	01.04		
09 99 000 0501	31.08	27 71 040 0001	00.08			60 01 026 5132	01.06	60 05 068 5100	01.23
09 99 000 0501	31.09	27 71 040 0002	00.08	33 56 224 5000 001	40.09	60 01 026 5140	01.06	60 05 068 5100	22.07
09 99 000 0501	31.10							60 05 068 5322	20.07
09 99 000 0503	31.08					60 01 050 5102	01.04		
09 99 000 0503	31.09	27 99 000 0001	32.02	33 60 211 0010 089	40.04	60 01 050 5132	01.06		
09 99 000 0504	31.08			33 60 211 0020 090	40.04	60 01 050 5140	01.06	60 06 050 5440	01.24
09 99 000 0506	30.12			33 60 211 0050 091	40.04			60 06 050 9001	01.24
09 99 000 0507	31.09			33 60 211 0100 092	40.04				
09 99 000 0507	31.10	33 18 243 0100 063	40.10	33 60 211 0150 093	40.04	60 01 068 5102	01.04	60 06 068 5440	01.24
09 99 000 0508	31.08	33 18 243 0200 064	40.10	33 60 211 0200 094	40.04	60 01 068 5132	01.06	60 06 068 9001	01.24

Part No.

List of part numbers



Part No.	Page	Part No.	Page	Part No.	Page	Part No.	Page	Part No.	Page
60 11 014 5732	01.13	60 13 014 0146 110	01.19	61 03 000 0045	07.20	61 03 000 5165	07.20	61 03 600 0017	31.12
60 11 014 5732	22.09	60 13 014 0146 351	01.19	61 03 000 0046	07.20	61 03 000 5166	07.20	61 03 600 0018	31.12
60 11 014 5732 710	01.13	60 13 014 0153 351	01.18	61 03 000 0047	07.20			61 03 600 0020	31.12
60 11 014 5732 710	22.09	60 13 014 5205	01.14	61 03 000 0048	07.20			61 03 600 0021	31.12
60 11 014 5740	01.13	60 13 014 5215	01.14	61 03 000 0049	07.20	61 03 001 0010	07.11		
60 11 014 5740	22.09			61 03 000 0050	07.20	61 03 001 0010 010	07.11		
60 11 014 5740 710	01.13	60 13 020 0153	01.18	61 03 000 0051	07.20	61 03 001 0011	07.16		
60 11 014 5740 710	22.09	60 13 020 5200	01.14	61 03 000 0052	07.20	61 03 001 0012	07.16		
				61 03 000 0053	07.20	61 03 001 0013	07.11	66 63 009 5013	07.22
60 11 020 5732	01.13	60 13 026 0146 110	01.19	61 03 000 0054	07.20	61 03 001 0013 010	07.11	66 63 009 5014	07.22
60 11 020 5732	22.09	60 13 026 0146 351	01.19	61 03 000 0055	07.20	61 03 001 0014	07.11	66 63 009 5017	07.24
60 11 020 5732 710	01.13	60 13 026 0153 351	01.18	61 03 000 0056	07.20	61 03 001 0015	07.11	66 63 009 5018	07.24
60 11 020 5732 710	22.09	60 13 026 0555	01.18	61 03 000 0057	07.20	61 03 001 0016	07.11	66 63 009 6004	07.23
60 11 020 5740	01.13	60 13 026 5205	01.14	61 03 000 0058	07.20	61 03 001 0017	07.11	66 63 009 6016	07.23
60 11 020 5740	22.09	60 13 026 5215	01.14	61 03 000 0059	07.20	61 03 001 0018	07.11		
60 11 020 5740 710	01.13			61 03 000 0060	07.20	61 03 001 0019	07.11		
60 11 020 5740 710	22.09	60 13 036 0146 110	01.19	61 03 000 0061	07.20	61 03 001 0020	07.16	66 67 009 0346	07.12
		60 13 036 0146 351	01.19	61 03 000 0062	07.20	61 03 001 0021	07.16	66 67 009 0347	07.12
		60 13 036 0153 351	01.18	61 03 000 0063	07.20	61 03 001 0022	07.16		
60 11 026 5102	01.11	60 13 036 5205	01.14	61 03 000 0064	07.20	61 03 001 0118	07.12		
60 11 026 5732	01.13	60 13 036 5215	01.14	61 03 000 0065	07.20	61 03 001 0118 010	07.12		
60 11 026 5732	22.09			61 03 000 0066	07.20	61 03 001 0119	07.12		
60 11 026 5732 710	01.13	60 13 050 0153	01.18	61 03 000 0067	07.20	61 03 001 0119 010	07.12		
60 11 026 5732 710	22.09	60 13 050 5200	01.14	61 03 000 0068	07.20	61 03 001 1010	07.11		
60 11 026 5740	01.13			61 03 000 0069	07.20	61 03 001 1010 010	07.11		
60 11 026 5740	22.09	60 13 068 0153	01.18	61 03 000 0070	07.20	61 03 001 1010 123	07.19		
60 11 026 5740 710	01.13	60 13 068 5200	01.14	61 03 000 0071	07.20	61 03 001 1013	07.11		
60 11 026 5740 710	22.09			61 03 000 0072	07.20	61 03 001 1013 010	07.11		
				61 03 000 0072	07.20	61 03 001 1014	07.11		
60 11 036 5102	01.11	60 90 005 6009	40.03	61 03 000 0098	31.12	61 03 001 1015	07.11		
60 11 036 5732	01.13	60 90 005 6010	40.03	61 03 000 0099	31.12	61 03 001 1016	07.11		
60 11 036 5732	22.09			61 03 000 0100	31.12	61 03 001 1017	07.11		
60 11 036 5732 710	01.13	60 90 010 6010	40.03	61 03 000 0101	31.12	61 03 001 1018	07.11		
60 11 036 5732 710	22.09			61 03 000 0102	31.12	61 03 001 1019	07.11		
60 11 036 5740	01.13	60 90 013 6010	40.03	61 03 000 0103	31.12	61 03 001 1118	07.12		
60 11 036 5740	22.09			61 03 000 0104	31.12	61 03 001 1118 010	07.12		
60 11 036 5740 710	01.13	60 90 018 6010	40.03	61 03 000 0105	31.12	61 03 001 1119	07.12		
60 11 036 5740 710	22.09			61 03 000 0127	07.20	61 03 001 1119 010	07.12		
		60 90 025 6010	40.03	61 03 000 0141	07.20	61 03 001 2010	07.11		
				61 03 000 0142	07.20	61 03 001 2010 010	07.11		
60 11 050 5102	01.11	60 90 034 6010	40.03	61 03 000 0143	07.20	61 03 001 2010 123	07.19		
60 11 050 5732	01.13			61 03 000 0145	07.20	61 03 001 2013	07.11		
60 11 050 5732	22.09	60 90 050 6008	40.06	61 03 000 0165	07.20	61 03 001 2013 010	07.11		
60 11 050 5732 710	01.13	60 90 050 6010	40.03	61 03 000 0166	07.20	61 03 001 2014	07.11		
60 11 050 5732 710	22.09			61 03 000 0168	31.12	61 03 001 2015	07.11		
60 11 050 5740	01.13	60 90 068 6008	40.06	61 03 000 0169	31.12	61 03 001 2016	07.11		
60 11 050 5740	22.09			61 03 000 0172	31.12	61 03 001 2017	07.11		
60 11 050 5740 710	01.13			61 03 000 0173	31.12	61 03 001 2018	07.11		
60 11 050 5740 710	22.09	60 99 000 0007	32.03	61 03 000 0174	31.12	61 03 001 2019	07.11		
		60 99 000 0010	32.02	61 03 000 0175	31.12	61 03 001 2118	07.12		
		60 99 000 0010	32.03	61 03 000 0176	31.12	61 03 001 2118 010	07.12		
60 11 068 5102	01.11	60 99 000 0011	32.02	61 03 000 0177	31.12	61 03 001 2119	07.12		
60 11 068 5732	01.13	60 99 000 0011	32.03	61 03 000 0178	31.12	61 03 001 2119 010	07.12		
60 11 068 5732	22.09	60 99 000 0016	32.02	61 03 000 0179	31.12	61 03 001 3010	07.11		
60 11 068 5732 710	01.13	60 99 000 0016	32.03	61 03 000 0180	31.12	61 03 001 3010 010	07.11		
60 11 068 5732 710	22.09	60 99 000 0017	32.02	61 03 000 0180	31.12	61 03 001 3013	07.11		
60 11 068 5739	22.10	60 99 000 0017	32.02	61 03 000 5062	07.20	61 03 001 3013 010	07.11		
60 11 068 5740	01.13	60 99 000 0017	32.03	61 03 000 5063	07.20	61 03 001 3014	07.11		
60 11 068 5740	22.09	60 99 000 0031	30.10	61 03 000 5064	07.20	61 03 001 3015	07.11		
60 11 068 5740 710	01.13	60 99 000 0032	30.10	61 03 000 5065	07.20	61 03 001 3016	07.11		
60 11 068 5740 710	22.09	60 99 000 0034	32.04	61 03 000 5066	07.20	61 03 001 3017	07.11		
60 11 068 5749	22.10	60 99 000 0038	32.03	61 03 000 5067	07.20	61 03 001 3018	07.11		
				61 03 000 5068	07.20	61 03 001 3019	07.11		
				61 03 000 5069	07.20	61 03 001 3118	07.12		
60 13 . . . 5200	32.02	61 03 000 0041	07.20	61 03 000 5070	07.20	61 03 001 3118 010	07.12		
60 13 . . . 5205	32.02	61 03 000 0042	07.20	61 03 000 5071	07.20	61 03 001 3119	07.12		
60 13 . . . 5215	32.02	61 03 000 0044	07.20	61 03 000 5072	07.20	61 03 001 3119 010	07.12		

Please send me further information:



Interface Connectors



Device Connectivity



Industrial Connectors Han®

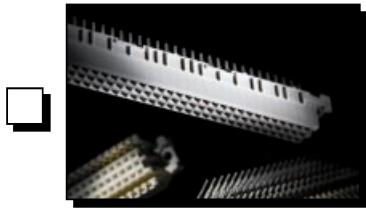

**Connectors
DIN 41612**



**Intelligent Network
Solutions**

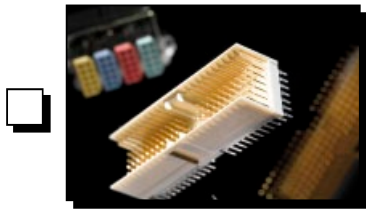

**Coaxial and Metric
Connectors**



**Application
brochure**



TCA Connectors

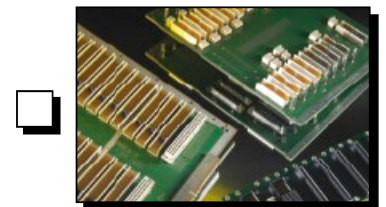

**High Speed
Backplanes**

Sender:

Company: _____

Street: _____

Department: _____

Postcode/Town: _____

Name: _____

Country: _____

Prenome: _____

Phone: _____

Function: _____

Fax: _____

Please send it by post or fax to your local HARTING representatives (see page addresses) or visit us under www.HARTING.com.

E-Mail: _____

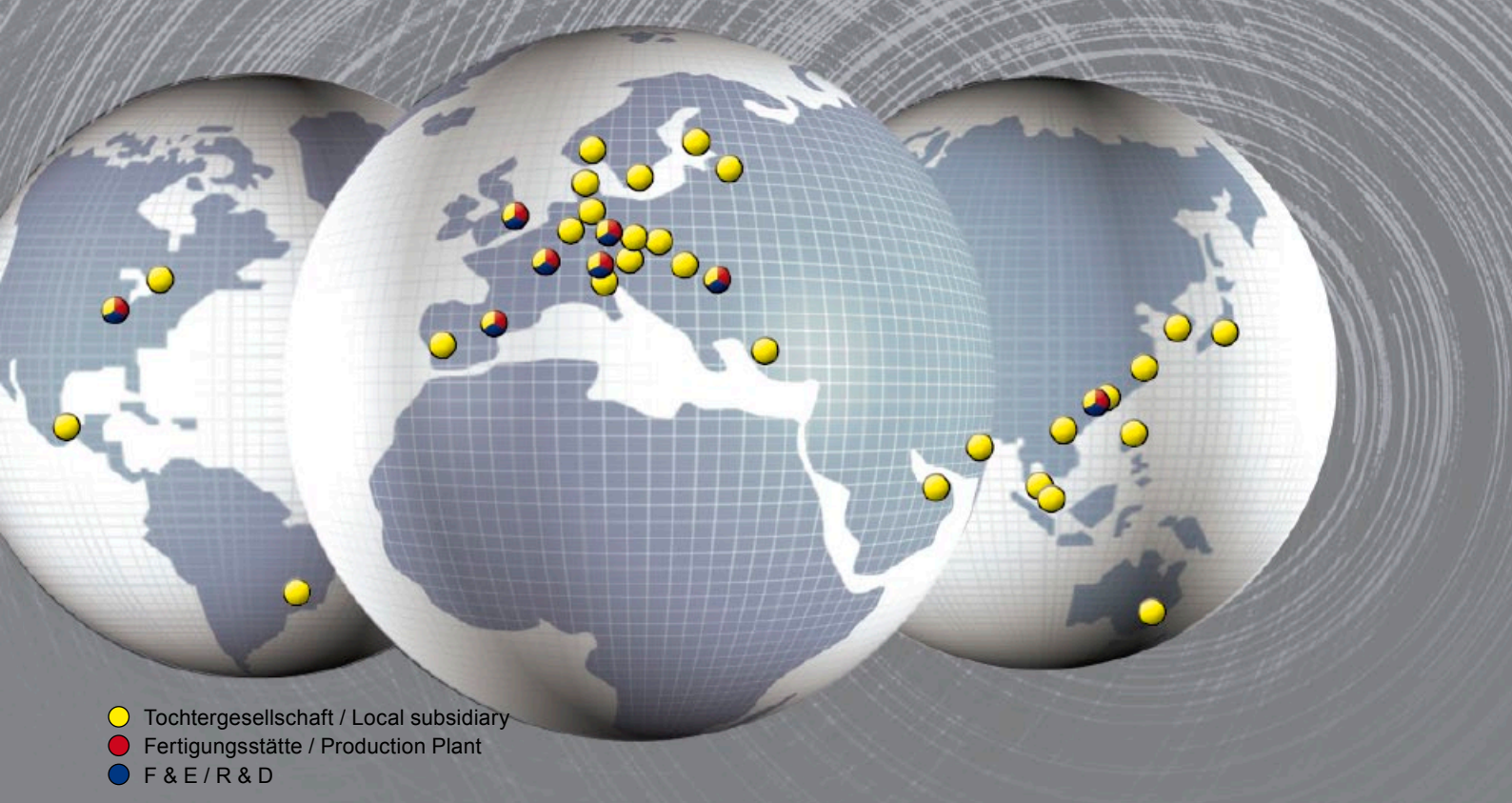

- Tochtergesellschaft / Local subsidiary
- Fertigungsstätte / Production Plant
- F & E / R & D

Sales Network – worldwide



Afghanistan

see United Arab Emirates

Albania: see Eastern Europe

Argentina

Condelectric S.A.
Hipólito Yrigoyen 2591, 1640 - Martínez
Buenos Aires – Argentina
Phone +54 11 4836 1053
Fax +54 11 4836 1053
comercial@condelectric.com.ar

Armenia: see Eastern Europe

Australia

HARTING Pty Ltd
Suite 11 / 2 Enterprise Drive
Bundoora 3083, AUS-Victoria
Phone +61 3 9466 7088
Fax +61 3 9466 7099
au@HARTING.com
www.HARTING.com.au

Austria

HARTING Ges.m.b.H.
Deutschstraße 19, A-1230 Wien
Phone +431 6162121
Fax +431 6162121-21
at@HARTING.com
www.HARTING.at

Azerbaijan: see Eastern Europe

Bahrain: see United Arab Emirates

Belgium

HARTING N.V./S.A.
Z.3 Doornveld 23, B-1731 Zellik
Phone +32 2 466 0190
Fax +32 2 466 7855
be@HARTING.com
www.HARTING.be

Bosnia and Herzegovina

see Eastern Europe

Brazil

HARTING Ltda.
Rua Major Paladino 128 –
Prédio 11
CEP 05307-000 – São Paulo –
SP – Brasil
Phone +55 11 5035 0073
Fax +55 11 5034 4743
br@HARTING.com
www.HARTING.com.br

Brunei: see Singapore

Bulgaria: see Eastern Europe

Canada

HARTING Canada Inc.
8455 Trans-Canada Hwy., Suite 202 St.
Laurent, QC, H4S1Z1, Canada
Phone 855-659-6653,
Fax 855-659-6654
info.ca@HARTING.com
www.HARTING.ca

China

HARTING (Zhuhai)
Manufacturing Co., Ltd.
Shanghai Branch, Room 3501- 3503,
No. 1, Hong Qiao Road, Grand Gateway I
Xu Hui District, Shanghai 200030, China
Phone +86 21 6386 2200
Fax +86 21 6386 8636
cn@HARTING.com
www.HARTING.com.cn

Croatia: see Eastern Europe

Czech Republic

HARTING s.r.o.
Mlýnská 2, CZ-160 00 Praha 6
Phone +420 220 380 460
Fax +420 220 380 461
cz@HARTING.com
www.HARTING.cz

Denmark

HARTING ApS
Hjulmagervej 4a
DK - 7100 Vejle
Phone +45 70 25 00 32
Fax +45 75 80 64 99
dk@HARTING.com
www.HARTING.dk

Eastern Europe

HARTING Eastern Europe GmbH
Bamberger Straße 7
D-01187 Dresden
Phone +49 351 4361 760
Fax +49 351 436 1770
Eastern.Europe@HARTING.com
www.HARTING.com

Egypt: see United Arab Emirates

Estonia: see Eastern Europe

Finland

HARTING Oy
Teknobulevardi 3-5
FI-01530 Vantaa
Phone +358 207 291 510
Fax +358 207 291 511
fi@HARTING.com
www.HARTING.fi

France

HARTING France
181 avenue des Nations, Paris Nord 2
BP 66058 Tremblay en France
F-95972 Roissy Charles de Gaulle Cédex
Phone +33 1 4938 3400
Fax +33 1 4863 2306
fr@HARTING.com
www.HARTING.fr

Germany

HARTING Deutschland GmbH & Co. KG
P.O. Box 2451, D-32381 Minden
Simeons carré 1, D-32427 Minden
Phone +49 571 8896 0
Fax +49 571 8896 282
de@HARTING.com
www.HARTING.de

Georgia: see Eastern Europe

Great Britain

HARTING Ltd., Caswell Road
Brackmills Industrial Estate
GB-Northampton, NN4 7PW
Phone +44 1604 827 500
Fax +44 1604 706 777
gb@HARTING.com
www.HARTING.co.uk

Hong Kong

HARTING (HK) Limited
Regional Office Asia Pacific
3512 Metroplaza Tower 1
223 Hing Fong Road
Kwai Fong, N. T., Hong Kong
Phone +852 2423 7338
Fax +852 2480 4378
ap@HARTING.com
www.HARTING.com.hk

Hungary

HARTING Magyarország Kft.
Fehérvári út 89-95, H-1119 Budapest
Phone +36 1 205 34 64
Fax +36 1 205 34 65
hu@HARTING.com
www.HARTING.hu

India

HARTING India Pvt Ltd
7th Floor (West Wing), Central Square II
Unit No.B-19 Part, B 20&21
TVK Industrial Estate
Guindy, Chennai - 600032
Phone +91-44-43560415
+91-44-43456262
Fax +91-44-43560417
in@HARTING.com
http://www.HARTING.in

Indonesia: see Malaysia

Iran: see United Arab Emirates

Iraq: see United Arab Emirates

Israel

COMTEL
Israel Electronic Solutions Ltd.
Bet Hapamon, 20 Hataas st.
P.O.Box 66
Kefar-Saba 44425
Phone +972-9-7677240
Fax +972-9-7677243
sales@comtel.co.il
www.comtel.co.il

Italy

HARTING SpA
Via Dell' Industria 7
I-20090 Vimodrone (Milano)
Phone +39 02 250801
Fax +39 02 2650 597
it@HARTING.com
www.HARTING.it

Japan

HARTING K. K.
Yusen Shin-Yokohama 1 Chome Bldg., 2F
1-7-9, Shin-Yokohama, Kohoku
Yokohama 222-0033 Japan
Phone +81 45 476 3456
Fax +81 45 476 3466
jp@HARTING.com
www.HARTING.co.jp

Jemen: see United Arab Emirates

Jordan: see United Arab Emirates

Kazakhstan: see Eastern Europe

Kirghizia: see Eastern Europe

Korea (South)

HARTING Korea Limited
#308 Yatap Leaders Building
342-1, Yatap-dong, Bundang-gu
Sungnam-City, Kyunggi-do
463-828, Republic of Korea
Phone +82 31 781 4615
Fax +82 31 781 4616
kr@HARTING.com
www.HARTING.co.kr

Kosovo: see Eastern Europe

Kuwait: see United Arab Emirates

Latvia: see Eastern Europe

Lebanon: see United Arab Emirates

Lithuania: see Eastern Europe

Macedonia: see Eastern Europe

Malaysia (Office)

HARTING Singapore Pte Ltd
Malaysia Branch
11-02 Menara Amcorp
Jln. Persiaran Barat
46200 PJ, Sel. D. E., Malaysia
Phone +60 3 / 7955 6173
Fax +60 3 / 7955 5126
sg@HARTING.com

Montenegro: see Eastern Europe

Netherlands

HARTING B.V.
Larenweg 44
NL-5234 KA 's-Hertogenbosch
Postbus 3526
NL-5203 DM 's-Hertogenbosch
Phone +31 736 410 404
Fax +31 736 440 699
nl@HARTING.com
www.HARTINGbv.nl

New Zealand: see Australia

Norway

HARTING A/S
Østensjøveien 36, N-0667 Oslo
Phone +47 22 700 555
Fax +47 22 700 570
no@HARTING.com
www.HARTING.no

Oman: see United Arab Emirates

Pakistan: see United Arab Emirates

Philippines: see Malaysia

Poland

HARTING Polska Sp. z o. o
ul. Duńska 9
PL- 54-427 Wrocław
Phone +48 71 352 81 71
Fax +48 71 350 42 13
pl@HARTING.com
www.HARTING.pl

Portugal

HARTING Iberia, S. A.
Avda. Josep Tarradellas 20-30 4º 6a
E-08029 Barcelona
Phone +351 219 673 177
Fax +351 219 678 457
es@HARTING.com
www.HARTING.es/pt

Qatar: see United Arab Emirates

Republic of Moldova
see Eastern Europe

Romania

HARTING Romania SCS
Europa Unita str. 21
550018-Sibiu, Romania
Phone +40 369-102 671
Fax +40 369-102 622
ro@HARTING.com
www.HARTING.com

Russia

HARTING ZAO
Maliy Sampsoniyevsky prospect 2A
194044 Saint Petersburg, Russia
Phone +7 812 327 6477
Fax +7 812 327 6478
ru@HARTING.com
www.HARTING.ru

Saudi Arabia

see United Arab Emirates

Serbia: see Eastern Europe

Singapore

HARTING Singapore Pte Ltd.
25 International Business Park
#04-108 German Centre
Singapore 609916
Phone +65 6225 5285
Fax +65 6225 9947
sg@HARTING.com
www.HARTING.sg

Slovakia

HARTING s.r.o.
Sales office Slovakia
J. Simora 5, SK - 940 52 Nové Zámky
Phone +421 356-493 993
Fax +421 356-402 114
sk@HARTING.com
www.HARTING.sk

Slovenia: see Eastern Europe

South Africa

HARTING South Africa (Pty) Ltd
Ground Floor, Twickenham Building
PO Box 67302
Johannesburg (Bryanston)
2021, South Africa
Phone +27 (0) 11 575 0017
Fax +27 (0) 11 576 6000
za@HARTING.com
www.HARTING.co.za

Spain

HARTING Iberia S.A.
Avda. Josep Tarradellas 20-30 4º 6ª
E-08029 Barcelona
Phone +34 93 363 84 75
Fax +34 93 419 95 85
es@HARTING.com
www.HARTING.es

Sweden

HARTING AB
Gustavslundsvägen 141 B 4tr
S-167 51 Bromma
Phone +46 8 445 7171
Fax +46 8 445 7170
se@HARTING.com
www.HARTING.se

Switzerland

HARTING AG
Industriestrasse 26
CH-8604 Volketswil
Phone +41 44 908 20 60
Fax +41 44 908 20 69
ch@HARTING.com
www.HARTING.ch

Syria: see United Arab Emirates

Taiwan

HARTING Taiwan Ltd.
Room 1, 5/F
495 GuangFu South Road
RC-110 Taipei, Taiwan
Phone +886 2 2758 6177
Fax +886 2 2758 7177
tw@HARTING.com
www.HARTING.com.tw

Tajikistan: see Eastern Europe

Thailand: see Malaysia

Turkey

HARTING TURKEI Elektronik Ltd. Şti.
Barbaros Mah. Dereboyu Cad.
Fesleğen Sok.
Uphill Towers, A-1b Kat:8 D:45
34746 Ataşehir, İstanbul
Phone +90 216 688 81 00
Fax +90 216 688 81 01
tr@HARTING.com
www.HARTING.com.tr

Turkmenistan: see Eastern Europe

Ukraine: see Eastern Europe

United Arab Emirates

HARTING Middle East FZ-LLC
Knowledge Village, Block 2A, Office F72
P.O. Box 454372, Dubai
United Arab Emirates
Tel. +971 4 453 9737
Fax +971 4 439 0339
uae@HARTING.com
www.HARTING.ae

USA

HARTING Inc. of North America
1370 Bowes Road
USA-Elgin, Illinois 60123
Phone +1 (877) 741-1500 (toll free)
Fax +1 (866) 278-0307 (Inside Sales)
us@HARTING.com
www.HARTING-USA.com

Uzbekistan: see Eastern Europe

Vietnam: see Singapore

Distributors – worldwide



Digi-Key Corporation:
www.digikey.com

Farnell:
www.farnell.com

FUTURE Electronics:
www.futureelectronics.com

Mouser Electronics:
www.mouser.com

RS Components:
www.rs-components.com

Other countries and general contact



HARTING Electronics GmbH
P.O. Box 1433
32328 Espelkamp - Germany
Phone +49 5772/47-97200
Fax +49 5772/47-777
electronics@HARTING.com

General information



It is the customer's responsibility to check whether the components illustrated in this catalogue also comply with different regulations from those stated in special fields of applications.

We reserve the right to modify designs or substance of content in order to improve quality, keep pace with technological advancement or meet particular requirements in production.

No part of this catalogue may be reproduced in any form (print, photocopy, microfilm or any other process) or processed, duplicated or distributed by means of electronic systems without the prior written consent of HARTING Electronics GmbH, Espelkamp. We are bound by the German version only.



Pushing Performance

HARTING Technology Group

Marienwerderstr. 3, 32339 Espelkamp – Germany

P.O. Box 11 33, 32325 Espelkamp – Germany

Phone +49 5772 47-0, Fax +49 5772 47-400

info@HARTING.com

www.HARTING.com

Looking for pricing, stock, or lifecycle information?

Click below to explore more details on WIN SOURCE:

 [View 09670029078](#) on WIN SOURCE

 [HARTING](#) Information

Optimize Your Supply Chain with WIN SOURCE Solutions

-  Global Sourcing Solution
-  Obsolete Management
-  Cost Control Management
-  Shortage Management
-  Alternative Solution
-  Excess Inventory Management