



THE DATASHEET OF ELI70-CR



User's Manual

ELI70-CR



Revision 1.05

FDI *Future Designs, Inc.*
Your Development Partner
996 A Cleaner Way, Huntsville, AL 35805

Copyright ©2018, Future Designs, Inc., All Rights Reserved

Important Legal Information

Information in this document is provided solely to enable the use of Future Designs, Inc. (FDI) products. FDI assumes no liability whatsoever, including infringement of any patent or copyright. FDI reserves the right to make changes to these specifications at any time, without notice. No part of this document may be reproduced or transmitted in any form or by any means, electronic or mechanical, for any purpose, without the express written permission of Future Designs, Inc. 996 A Cleaner Way, Huntsville, AL 35805.

Microsoft, MS-DOS, Windows, Windows XP, Microsoft Word are registered trademarks of Microsoft Corporation. Other brand names are trademarks or registered trademarks of their respective owners.

Printed in the United States of America.

For more information on FDI or our products please visit <https://www.teamfdi.com>.
©2024 Future Designs, Inc. All rights reserved.

Revision: 1.05, 3/18/2024



Important Legal Information.....	2
1.0 Introduction	4
2.0 ELI70-CR Box Contents	4
3.0 Optional Accessories Recommended for Use (Purchased Separately).....	4
4.0 ESD Warning	5
5.0 Determining the Revision of your ELI.....	5
6.0 Technical Specifications	6
7.0 Connections.....	7
8.0 Power Details	7
9.0 Extended Display Information Data (EDID)	8
10.0 PWM Control of Backlight	9
11.0 Mechanical View.....	13
12.0 Support	14
12.1 Where to Get Help.....	14
12.2 Useful Links	14



1.0 Introduction

About ELI

ELI® is Future Designs, Inc.'s family of long-life, plug-and-play embedded displays. ELI products are true modular embedded display solutions that require no engineering or lead-time. All ELI products are compatible with a wide range of single board computers including Raspberry Pi, BeagleBone Black and Windows-based units. FDI designed ELI as an embedded display option that requires minimal development time to help customers reach production quickly. Once a product is in production, FDI's 10-15 year ELI product availability guarantee helps ensure production schedules without the risk of expensive or time consuming redesigns. Learn more about ELI at [TeamFDI.com/ELI](https://www.teamfdi.com/ELI).

ELI Compatibility

ELI products are compatible with most single board computers, PCs and operating systems. See <https://www.teamfdi.com/product-details/eli70-cr#compatibility> for the results of FDI's compatibility tests with popular operating systems and platforms. Our results, as indicated in the table, demonstrate ELI's versatility but the table is not exhaustive. ELI products are designed to work with any single board computer that has an HDMI output. To submit a question about ELI's compatibility with a platform or operating system that is not included in the table, contact a member of the FDI support team at Support@teamfdi.com.

Your ELI Experience

Share your experience connecting ELI devices to various (single board) computers at: <https://www.teamfdi.com/edid/#edidform>.

2.0 ELI70-CR Box Contents

- ELI70-CR

3.0 Optional Accessories Recommended for Use (Purchased Separately)

- 12V DC (+/- 5%) 2A Power Supply with a center positive barrel plug
 - 2.1mm I.D. x 5.5mm O.D. x 9.5mm
 - All ELI units operate from +12V DC so this is the recommended power supply input voltage for the entire Family. ELI70-CR units from Rev 2.3 and greater are also capable of operation from a range of +5 to 24V DC (+/- 5%)
- USB Type A to Mini Type B Cable (For touch)
- HDMI Cable (Type A Male)



4.0 ESD Warning

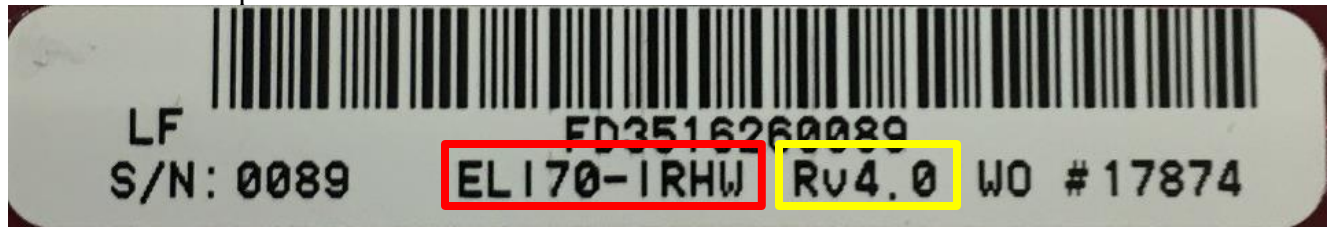

Figure 1. Electrostatic Sensitive Device

Our ELI units are shipped in a protective anti-static package. Do not subject the module to high electrostatic potentials. Exposure to high electrostatic potentials may cause damage to the boards that will not be covered under warranty. General practice for working with static sensitive devices should be followed when working with this device.

5.0 Determining the Revision of your ELI

All ELI devices have a label placed on the board to identify the part number and revision of the unit. This label will help you quickly and correctly identify your ELI unit's part number and revision number. An example of an ELI label is shown below.



ELI Part Number

ELI Revision Number



6.0 Technical Specifications

Table 1. Technical Specifications

Screen Size:	7.0 inches (diagonal)
Display Technology:	a-Si TFT LCD
Resolution:	800x480 (WVGA)
Brightness:	280 nits (typ)
Contrast Ratio:	500:1 (typ)
Aspect Ratio:	15:9
Interface Input Mode:	HDMI
Colors:	16.7M (24 bit)
Horizontal Viewing Angle:	70° L/R
Vertical Viewing Angle:	60° U / 70° D
Surface:	Anti-glare
Reverse Scan:	U/D, L/R
Touch Screen:	4-wire Resistive
Touch Screen Interface:	USB Device
Touch Panel Hardness:	>3H
Touch Panel Force:	100gF (max)
Active Area:	154.08(W) x 85.92(H) mm
Response Time:	25ms
Backlight:	24 LED (3S x 8P)
Backlight Life:	20K hours (typ)
Backlight Power Consumption:	1.55W (typ)
Operating Temperature:	-20° to 70° C
Storage Temperature:	-30° to 80° C
Input Voltage (Rev. 2.3 and above):	+5 to 24 VDC \pm 5%
Input Voltage (Rev. 2.2 and below):	+12VDC \pm 5%
Power Consumption:	400mA @ 12V (typ)
RoHS Compliant:	Yes
Dimensions:	164.9 (W) x 100.0 (H) x 22.6 (D) mm
Mounting:	#8 screw mounts in 4 corners
Weight:	255 grams



7.0 Connections

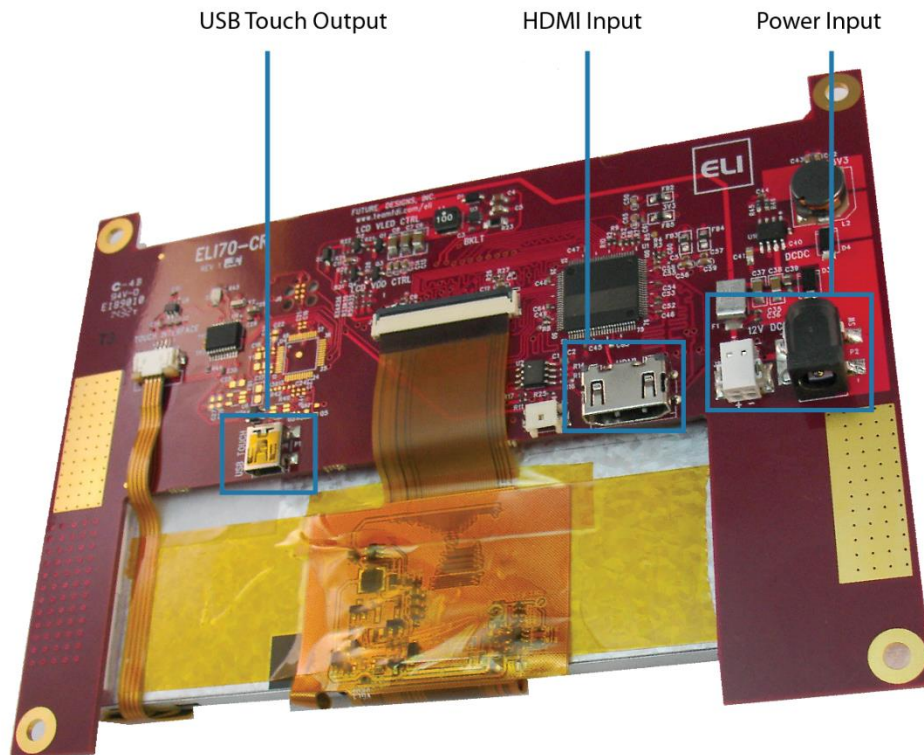

Figure 2. ELI70-CR Connections

8.0 Power Details

A 12VDC +/- 5% power supply with a 2.0A output will power any board from the ELI Family. This allows a common, off-the-shelf power supply such as the [T1071-P5P-ND](#) to be used for quick demos or prototyping across the entire ELI Family. In general, any 12VDC power supply with a 2.1mm center positive plug will be acceptable if it can provide enough current to power the particular ELI unit being used.

For volume production applications, the input power can be optimized for your particular ELI unit and lower capacity power supplies can be used.

On the ELI70-CR plug power into the (P2) connector. In cases where the barrel connector is not desired, you can use the alternate power input connector (J8) which supports directly plugging in 20-26 AWG wire with maximum 5A current per contact. The datasheet for this J8 connector (PCB terminal block - PTSM 0,5/ 2-2,5-H SMD WH R24 – 1814634) can be found at <https://tinyurl.com/1814634>.

On ELI70-CR units of Revision ≥ 2.3 and above, the input power range is expanded from +5 to 24V DC $\pm 5\%$ (2.0A) for greater design flexibility.

To verify that the ELI70-CR unit is correctly powered you may check input voltage with a Fluke multi-meter or scope by probing the +12V and GND contacts shown below. Please verify that the input voltage is present, and within the $\pm 5\%$ tolerance and is free from excessive noise or AC ripple.

Note: If using an input that is within the acceptable range of an ELI70-CR (Rev 2.3 and above), 5 to 24VDC ($\pm 5\%$), please keep in mind that the 12V Test points should be at the voltage of your chosen power supply (5-24VDC).

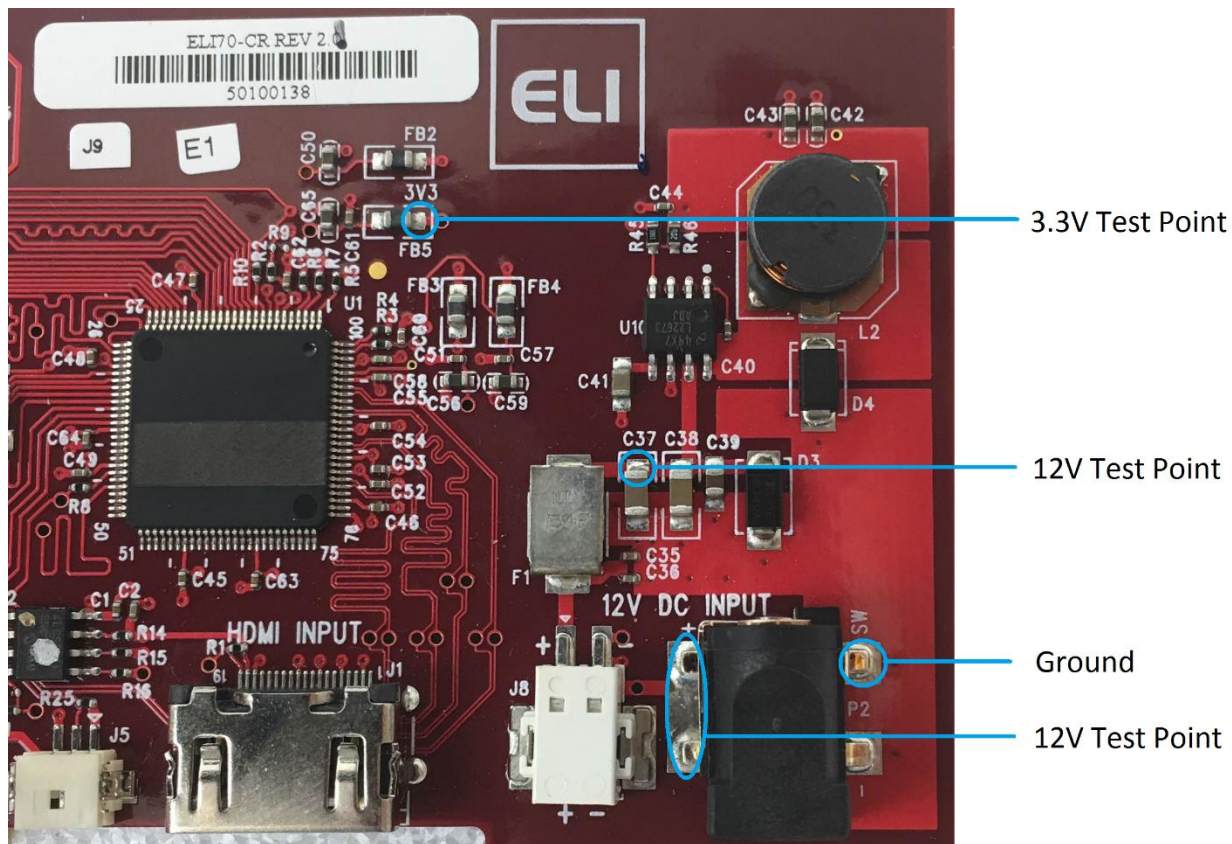

Figure 3. ELI70-CR Power Test Points

9.0 Extended Display Information Data (EDID)

ELI has fully working EDIDs for easier compatibility with many display adapters. You can find out more on our website at <https://www.teamfdi.com/edid/>.



10.0 PWM Control of Backlight

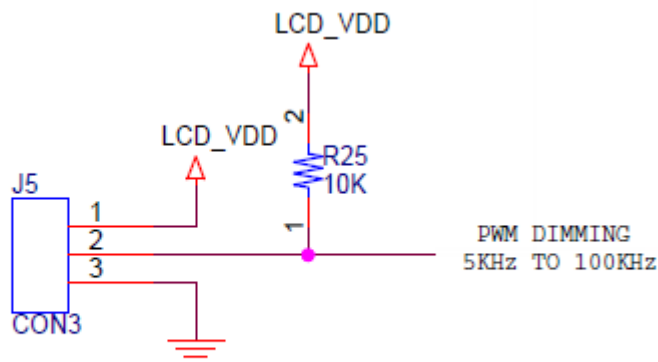

OPTIONAL PROCESSOR PWM BACKLIGHT CONTROL

Figure 4. PWM Backlight Control

J5 mating connector housing information:

- Manufacturer: Hirose
- Part Number: DF12-3S-1.25C
- Digi-Key Link: <https://www.digikey.com/products/en?keywords=H2180-ND>
- Pre-terminated wires <https://www.digikey.com/products/en?PPV=1811-9-566967>

ELI provides an input so an external processor can control the display backlight to vary the display brightness or to reduce power consumption (the display backlight is typically one of the larger sources of power consumption in the system). PWM dimming is an input with a 0 to 3.3 VDC range and the user should drive this with a push-pull type output or a suitable open collector output.

To control the display backlight, the user should connect an externally generated Pulse Width Modulated (PWM) signal to J5 pin 2 along with a common ground to J5 pin 3. The frequency range for this signal is from 5KHz to 100KHz. Each ELI unit's unique display backlight properties will vary, so the user should test their version for an acceptable range of brightness control. For example, the actual display 0 to 100% brightness range may only be 40% to 90% of the PWM range. In certain installations, a series resistor may be required to ensure a clean PWM signal is provided to the ELI. The suggested value for the resistor is 100ohms. See Figure 6 below for example of connectivity. Actual testing in your installation may require this resistor to be changed, or possibly not required at all.

On the ELI unit, the PWM dimming signal is pulled up to VDD providing 100% backlight power when no PWM signal is applied at pin 2 of J5. If nothing is connected to J5, the ELI will drive the display at 100% brightness (default).



The VDD output at pin 1 of J5 is a 3.3VDC \pm 5%. ELI provides the 3.3VDC signal, called VDD, for the external system in case this voltage is needed to generate the correct levels on the PWM Dimming Input. If the external system is capable of directly driving the PWM dimming signal at 3.3VDC, there is no need to connect pin 1 to the cable.

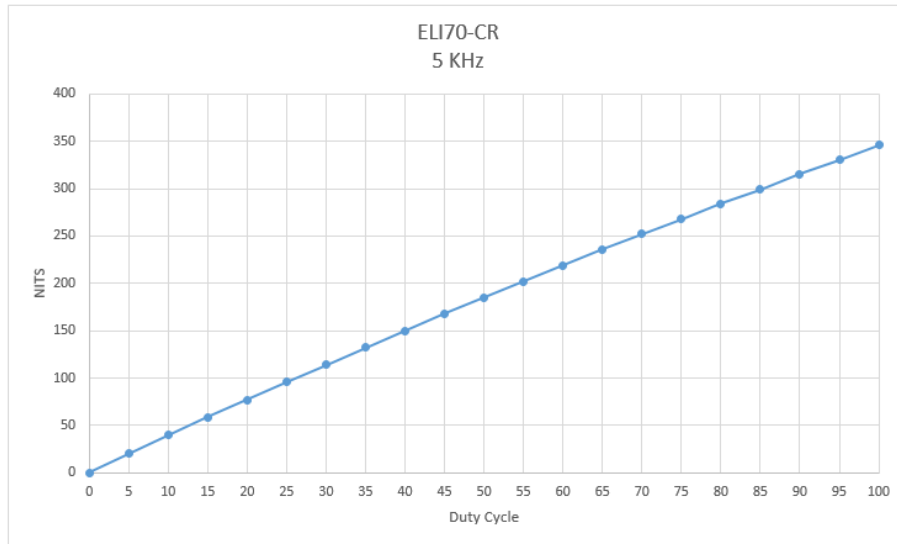

Figure 5. ELI70-CR Backlight Curve in Nits

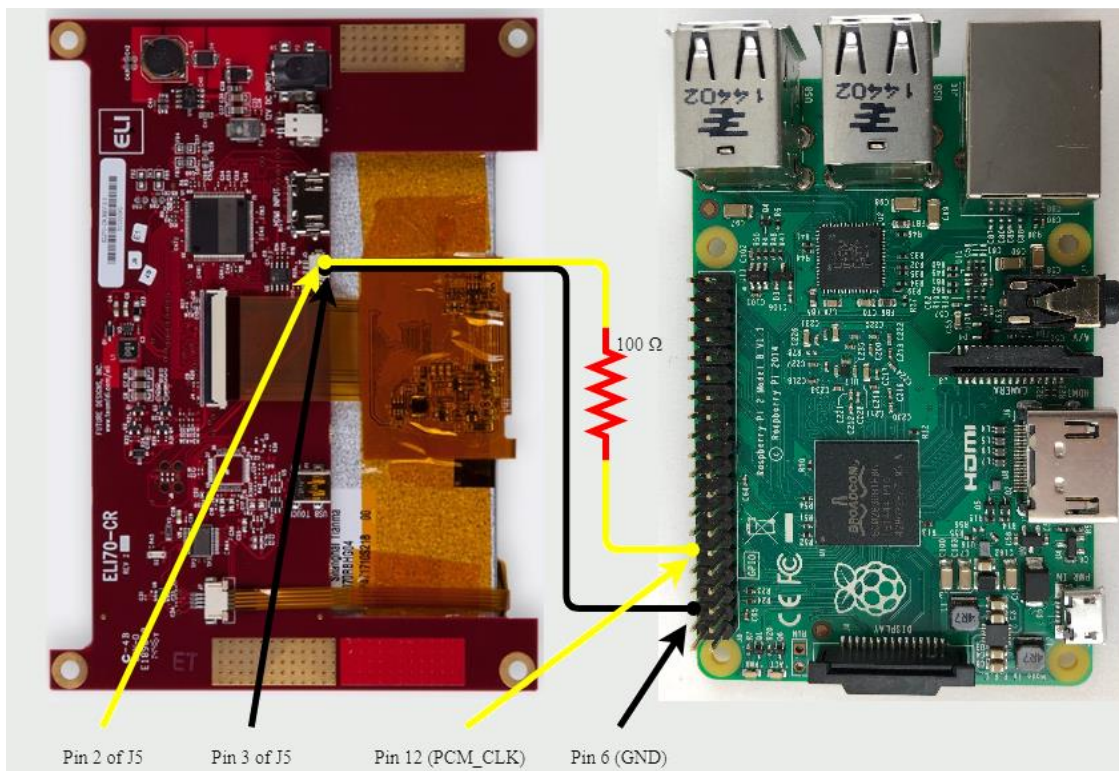

Figure 6. Raspberry Pi Signal and Ground

The ELI backlight can be controlled from a Raspberry Pi. See Figure 6 for a wiring diagram. Our software is available on the FDI website at <https://www.teamfdi.com/product-details/eli70-cr#software> or you may copy the code from here:

```
/* Changes brightness of ELI backlight given a
command line argument between 0 and the set
range. Uses bcm2835 header file provided by
Broadcom at
https://www.airspayce.com/mikem/bcm2835/bcm2835-1.52.tar.gz
This source code must be compiled using
"g++ brightness.cpp -o brightness -l bcm2835" in
order to properly link the header file. Must be
run using sudo, accessing GPIO pins requires root
permissions. After compiling, you may add
executable to "/usr/bin" which allows you to type
"sudo brightness <value>" to change brightness
anywhere in terminal. The "/boot/config.txt" file
must also be changed by adding a "#" before the
line "dtparam=audio=on". This disables audio
output from the Raspberry Pi. If this is not
disabled then anytime sound is output the screen
will return to 100% brightness.
```

```

*/

#include<iostream>
#include<bcm2835.h>
#include<string>

using namespace std;

#define LED RPI_GPIO_P1_12 // PWM pin number for
backlight control
#define RANGE 20 // Range for PWM steps
#define CLOCK 192 // Clock rate

int main(int argc, char *argv[]){

    int data = 0; // Brightness level

    if(argc != 2){ // Give user correct usage if
ran incorrectly
        cout << "Error: correct usage,
brightness <value>" << endl;
        return 1;
    }

    data = stoi(argv[1]);

    if(data > RANGE || data < 0){
        cout << "Error: brightness value must be
between 0 and " << RANGE << endl;
        return 1;
    }

    if(!bcm2835_init())
        return 1;

    bcm2835_gpio_set_pad(BCM2835_PAD_GROUP_GPIO_0_27,
BCM2835_PAD_DRIVE_2mA); // Sets the drive current
to 2mA
    bcm2835_gpio_fsel(LED,
BCM2835_GPIO_FSEL_ALT5); // Sets up pin 18 for
alt5 pwm mode

    bcm2835_pwm_set_clock(CLOCK); // Sets pwm
clock to 19.2 MHz / CLOCK
    bcm2835_pwm_set_mode(0,1,1); // Sets mode to
markspace
    bcm2835_pwm_set_range(0,RANGE); // Sets range
    bcm2835_pwm_set_data(0,data); // Sets data
rate to argument value

    bcm2835_close();
    return 0;
}

```



}

Figure 7. Backlight Control for Raspberry Pi

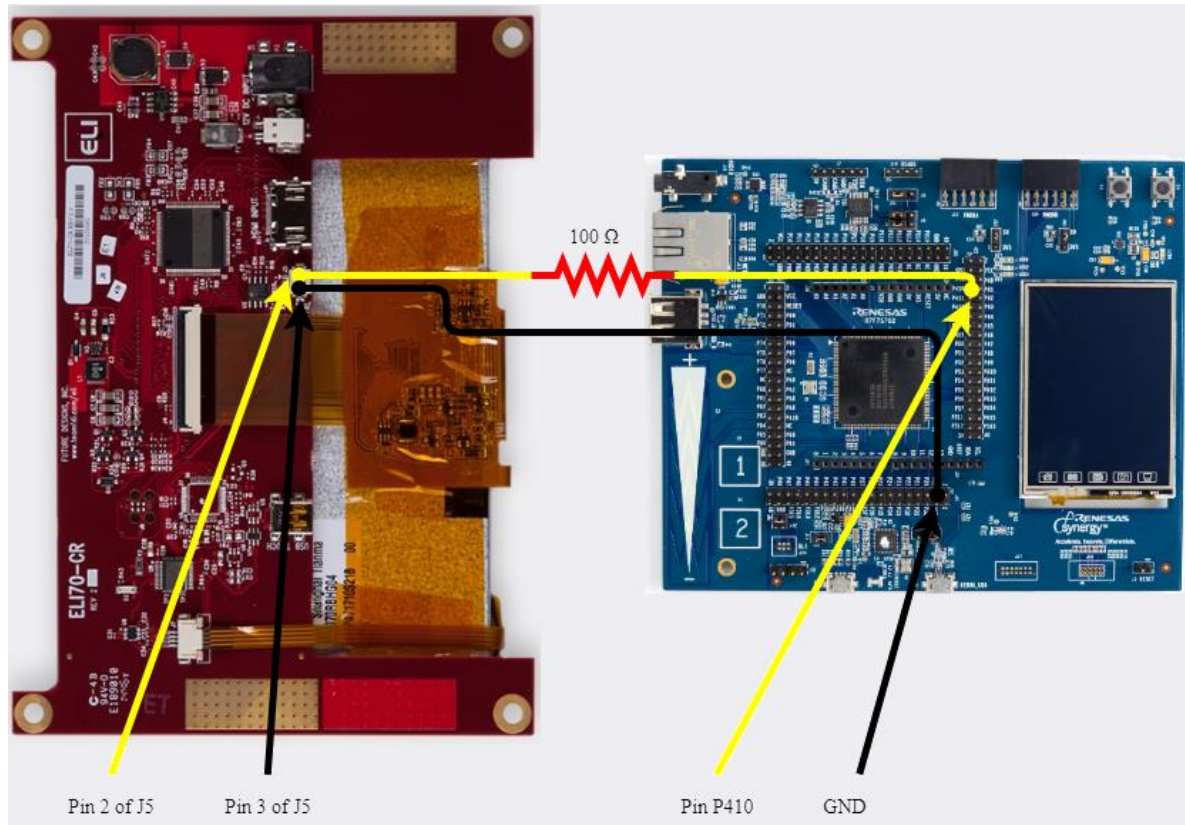

Figure 8. Renesas Synergy S7G2 Signal and Ground

The ELI backlight can also be controlled from a Renesas Synergy S7G2 wired as shown in Figure 8. The software for Synergy can be found on our website at <https://www.teamfdi.com/product-details/eli70-cr#software>.

11.0 Mechanical View

- Tape used for the LCD to PCB Attachment: 3M VHB 4959 ½" width
- 4 screw holes on the ELI70-CR accept up to #8 size screws for mounting into an enclosure and connect to the system ground directly.
- The exposed ground pads may be used to connect the ELI70-CR PCB directly to the LCD using copper or aluminum foil tape to help meet ESD requirements.



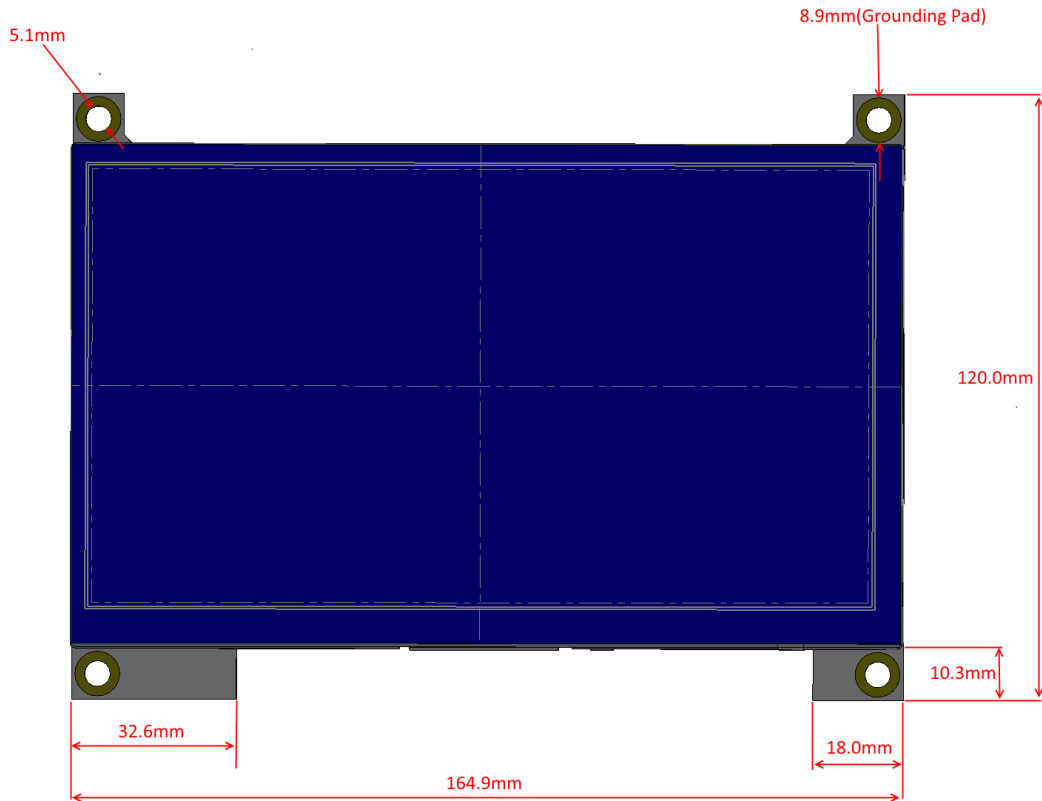

Figure 9. Front View with Measurements

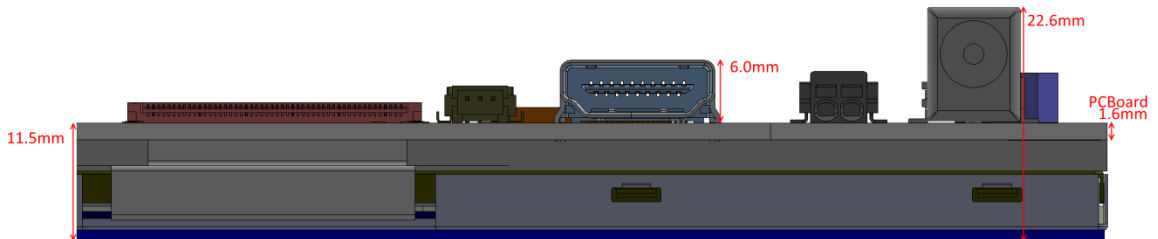

Figure 10. Partial Profile View

12.0 Support

12.1 Where to Get Help

Online technical support is available at <https://www.teamfdi.com/support/>.

12.2 Useful Links

- Future Designs, Inc. Forums: <https://www.teamfdi.com/forum>



- ELI70-CR Product Page: <https://www.teamfdi.com/product-details/eli70-cr/>
- ELI Software User's Manual: <https://fdiwebdocs.s3.us-east-2.amazonaws.com/2024/wp-content/uploads/ELI-Software-Users-Manual.pdf>
- Tell us about your ELI experience: <https://www.teamfdi.com/edid/#edidform>
- EDID Information Page: <https://www.teamfdi.com/edid/>



Looking for pricing, stock, or lifecycle information?

Click below to explore more details on WIN SOURCE:

 [View ELI70-CR on WIN SOURCE](#)

 [Future Designs Inc. Information](#)

Optimize Your Supply Chain with WIN SOURCE Solutions

-  Global Sourcing Solution
-  Obsolete Management
-  Cost Control Management
-  Shortage Management
-  Alternative Solution
-  Excess Inventory Management