

©2008 CARCLO
ALL DIMENSIONS IN mm

SECTION Y-Y

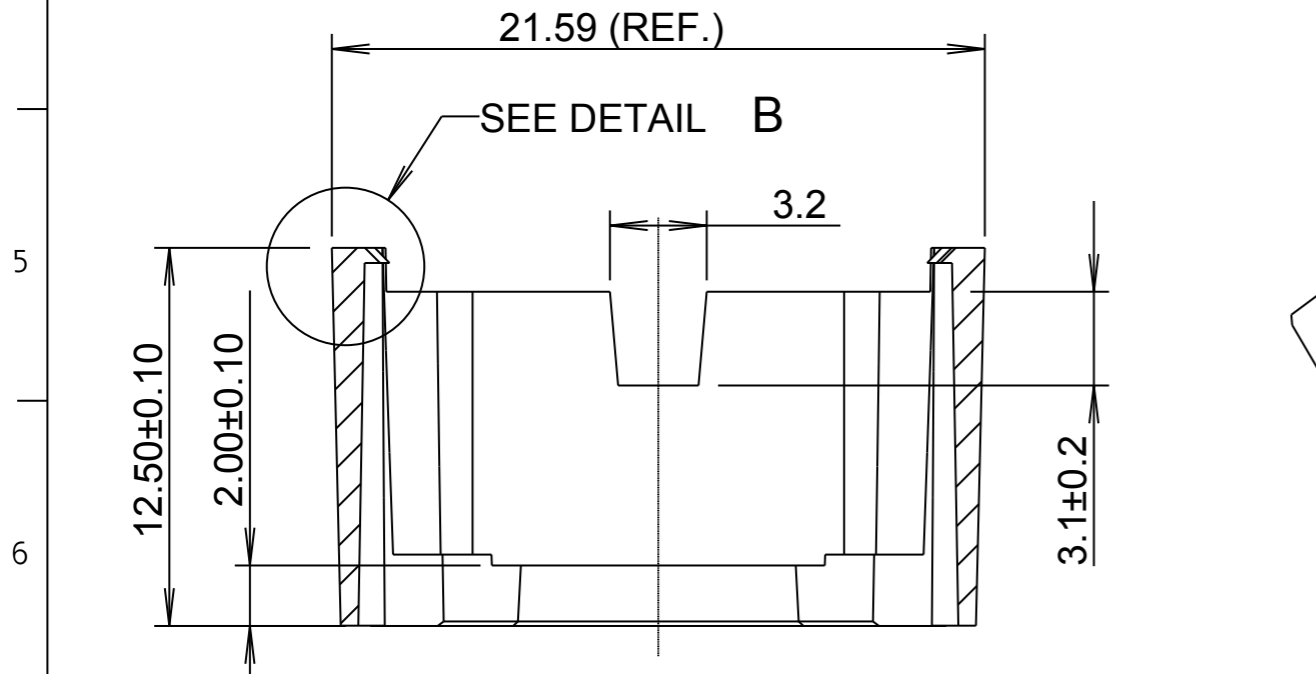

SECTION X-X

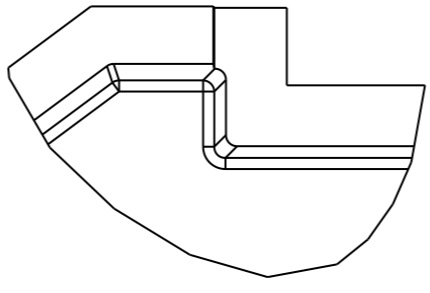

DETAIL A
SCALE 10:1

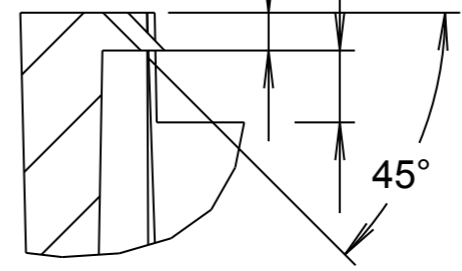

DETAIL B
SCALE 10:1

- NOTES:-
1. MATERIAL: SEE TABLE
2. FINISH: GOOD POLISH ALL OVER
3. GEN. WALL THK. 1mm
4. GEN DRAFT ANGLE 2 DEG.

⚠ DENOTES CRITICAL DIMENSION FOR INSPECTION

PART No.	DESCRIPTION
10205	BLACK POLYCARBONATE
10206	CLEAR POLYCARBONATE
10207	WHITE POLYCARBONATE

ISS.	DATE	E.C.N.	DESCRIPTION
1	20-Oct-06		FIRST ISSUE
2	19-Jan-09	01/09/1238	WIRING SLOTS REMOVED



CARCLO TECHNICAL PLASTICS (SLOUGH)
111 BUCKINGHAM AVE, SLOUGH
SL1 4PF, ENGLAND
TEL: +44 1753 575011 FAX: +44 1753 811359
email: design@carclo-optics.com

GENERAL TOLERANCES (UNLESS STATED)

LINEAR	ANGULAR
X +/- 0.25	X +/- 1°
X.X +/- 0.1	X.X +/- 0.5°
X.XX +/- 0.05	X.XX +/- 0.1°

CUSTOMER
CARCLO

TITLE
CREE HOLDER FOR 20MM OPTIC
WITH 1.4MM OFFSET FOCUS

DRAWN MKI DATE 20-Oct-06

CHK'D DATE



APP'D DATE

SCALE 4:1 CARCLO PART No. SEE TABLE

SIZE A3 CARCLO DRG. No. 60435 SHEET 1 OF 1

Looking for pricing, stock, or lifecycle information?

Click below to explore more details on WIN SOURCE:

-  [View 10205 on WIN SOURCE](#)
-  [Carclo Technical Plastics](#) Information

Optimize Your Supply Chain with WIN SOURCE Solutions

-  Global Sourcing Solution
-  Obsolete Management
-  Cost Control Management
-  Shortage Management
-  Alternative Solution
-  Excess Inventory Management