



**THE DATASHEET OF**  
**25622130**



# Front Panel Digital Timers TMR48 D

## Performance Version 48x48 mm

Syr-line MDA2, MDF1, GDF1, GDS2 Series

*Syr-line Digital Timers: higher precision and many programming features with the biggest screen ever seen in the timer relays' market and the most intuitive programming for ease to use and fast configuration.*

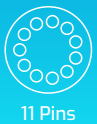
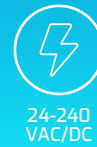

Electrical Control & Protection > Timer Relays > Front Panel > Digital

### Highlights

- Large LED or LCD Screen (13.2 mm)
- Multi-function and single-function
- Basic & Advance configuration modes
- Multi-range (0.05 s – 9999 h)
- Multi-voltage (24-240 VAC/DC)
- 1 or 2 relay outputs (Changeover)
- Memory option in event of a break in supply
- Lock function
- Up or down timing
- DIN Sized (48x48 mm) Housing
- Compact body (63 mm long)
- Water & Dust-proof (IP66)
- 8 Pins & 11 Pins connections

### Standards



### Part Numbers

MDA2R10MV2	MDF1R10MV2	GDF1R10MV2	GDS2R10MV2
Functions A Series: MDA2	Functions: A - Ac - Ad - B - C - H - L - Li - D - Di Series: MDF1	Functions: A - Ac - Ad - B - C - H - L - Li - D - Di Series: GDF1	Functions: A - Ab - Ac - Ad - AMt - At - B - C - H - Ht - L - Li - T - W - D - Di Series: GDS2

### Part numbering system

<b>Type:</b> MD: Digital 8 Pins GD: Digital 11 Pins	<b>Output Qty:</b> 1: 1 Output 2: 2 Outputs	<b>Output Power:</b> 10: 10 A 05: 5 A
<b>GD</b>	<b>S</b>	<b>1</b>
<b>R</b>	<b>10</b>	<b>MV2</b>
<b>Function:</b> A: ON-Delay E: Multifunction E F: Multifunction F S: Multifunction S	<b>Output Type:</b> R: Relay	<b>Power Supply:</b> MV2: 24-240 VAC/DC MVA: 100-240 VAC/DC 24U: 24 VAC/DC

### More Info.



## Specifications

	MDA2R10MV2	MDF1R10MV2	GDF1R10MV2	GDS2R10MV2
<b>Inputs</b>				
Supply voltage	24-240 VAC/DC			
Voltage supply tolerance	-15%, +10%			
AC supply voltage frequency	50/60 Hz $\pm$ 5%			
Galvanic isolation of supply / inputs	No			
Max power consumption at Un	2.5 VA (VAC) 1 W (VDC)			
Immunity to power micro cuts	10 ms			
<b>Timing</b>				
Timing ranges	IEC 1812-1: 0.001 s - 9.999 s, 0.01 s - 99.99 s, 0.1 s - 999.9 s, 1 s - 9999 s, 1 s - 99 min 59 s, 0.1 min - 999.9 min, 1 min - 9999 min, 1 min - 99 h 59 min, 0.1 h - 999.9 h, 1 h - 9999 h			
Minimum control pulse duration	IEC 1812-1: 1 ms or 20 ms selectable			
Recovery time (after by de-energization)	IEC 1812-1: 120 ms max			
Repeatability	IEC 1812-1: $\leq \pm 0.03\%$ $\pm 20$ ms (VDC) / 50 ms (VAC)			
Setting accuracy (full range)	IEC 1812-1: $\leq \pm 0.03\%$ $\pm 20$ ms (VDC) / 50 ms (VAC)			
Drift temperature	$\leq \pm 0.03\%$ $\pm 20$ ms (VDC) / 50 ms (VAC)			
Drift voltage	$\leq \pm 0.03\%$ $\pm 20$ ms (VDC) / 50 ms (VAC)			
<b>Outputs</b>				
Output configuration	2 CO (SPDT)	1 CO (SPDT)		2 CO (SPDT)
Maximum switching voltage	250 VAC / 10 A resistive / 125 VDC / 0.3 A resistive			
Switching current rate (resistive)	NO/NC: 2x10 A at 40°C 250 VAC / 2x10 A at 40°C 30 VDC NO/NC: 2x8 A at 60°C 250 VAC / 2x8A at 60°C 30 VDC	NO/NC: 10 A 250 VAC / 10 A 30 VDC		NO/NC: 2x10 A at 40°C 250 VAC / 2x10 A at 40°C 30 VDC NO/NC: 2x8 A at 60°C 250 VAC / 2x8A at 60°C 30 VDC
Maximum switching power (resistive)	2x2500 VA / 2x300 W	2500 VA / 300 W		2x2500 VA / 2x300 W
Electrical life (operations)	1x10 <sup>5</sup> cycles (10 A 250 VAC resistive)			
Minimum breaking current	10 mA / 12 VDC			
Maximum rate (at max switching power)	360 cycles / h			
Mechanical life (operations)	10x10 <sup>6</sup> cycles			
Dielectric strength	Between open contacts: 1 kV / 1 min / 1 mA / 50 Hz			
<b>Insulation</b>				
Rated insulation voltage	IEC 60664-1: 300 V			
Insulation coordination	IEC 60664-1: Overvoltage category III; pollution degree 2			
Rated impulse voltage	IEC 60664-1: 4 kV (1.2/50 $\mu$ s)			
Clearance / creepage distances	IEC 60664-1: 3 mm / 3.2 mm			
Dielectric strength	EN-61812-1: 2.5 kV / 1 min / 1 mA / 50 Hz			
Insulation resistance	NFC 93 050: > 500 M $\Omega$ / 250 VDC / 1 min			

## Specifications

	MDA2R10MV2	MDF1R10MV2	GDF1R10MV2	GDS2R10MV2
<b>General characteristics</b>				
Display	4 digits per value 7 segments LCD			
Memory backup	EEPROM (rewrite 1 000 000 times min, 40 years data hold min)			
Casing	48x48 mm (1/16 DIN)			
Mounting	Front panel, by clip Base-mounted on socket			
Mounting position	All positions			
Housing material	UL94: enclosure plastic type V0			
Degree of protection	IEC 60529: Front Face IP66 with front panel seal / Housing IP20			
Operating temperature	IEC 60068-2: -10°C to +60°C			
Storage temperature	IEC 60068-2: -30°C to +70°C			
Humidity	IEC 60068-2-30: 93% without condensation			
Vibration resistance	IEC 60068-2-6: $\pm 0.15$ mm 10 Hz - 60 Hz / 2 g 60 Hz - 150 Hz			
Shock resistance	IEC 60068-2-27: 15 gn – 11 ms, 3x6 axis (Output non-energized) / 5 gn – 11 ms, 3x6 axis (Output energized)			
Drop to concrete floor	IEC 60068-2-32: Height: 0.75 m			
Weight	Approx. 105 g (150 g with packing)			
<b>Standards</b>				
EU Directives	2014/30/EU: EMC 2014/35/EU: Low voltage			
Approvals / marking	CE, cULus Listed Industrial Control Equipment			
Security standard	IEC 60664-1: Insulation coordination for equipment within low-voltage systems			
Conformity with environmental directives	2015/863/UE: RoHS 1907/2006: Reach 2012/19/UE: WEEE			
Product standard	IEC 61812-1: Specified time relays for industrial use UL 508 (60947-4-1): Industrial Control Equipment (NRNT- Industrial Control Switches) IEC 61000-4-2: Level III			
Immunity to electrostatic discharges	Air $\pm 8$ kV Contact $\pm 6$ kV			
Immunity to radiated, radio-frequency, electromagnetic field	IEC 61000-4-3: Level III 10 V/m (80 MHz - 1 GHz) 80% AM (1 kHz) 3 V/m (1.4 - 2 GHz) 80% AM (1 kHz) 1 V/m (2 - 2.7 GHz) 80% AM (1 kHz)			
Immunity to rapid transient bursts	IEC 61000-4-4: Level IV Direct $\pm 4$ kV (power supply) Capacitive coupling clamp $\pm 2$ kV (command input and outputs)			
Immunity to shock waves on power supply	IEC 61000-4-5: Level III Line-to-earth $\pm 2$ kV Line-to-line $\pm 1$ kV			
Immunity to radiofrequency in common mode	IEC 61000-4-6: Level III 10 Vrms (0,15 - 80 MHz) 80% AM (1 kHz)			
Immunity to voltage dips and breaks	IEC 61000-4-11: Industrial Class II, 0% residual voltage during 1 cycle AC power ports, 70% residual voltage during 25/30 cycles AC power ports, 0% residual voltage, 250/300 cycles AC power ports. Residential: 0% residual voltage during 10 cycle AC power ports, 40% residual voltage during 10 cycles AC power ports, 70% residual voltage during 10 cycles AC power ports, 0% residual voltage, 250/300 cycles AC power ports.			
AC/DC main port emissions	EN55022 / CISPR22 Class B EN 55011 / CISPR11 Class B, Group 1			
Radiated emissions	EN55022 / CISPR22 Class B EN 55011 / CISPR11 Class B, Group 1			

**Dimensions (mm)**

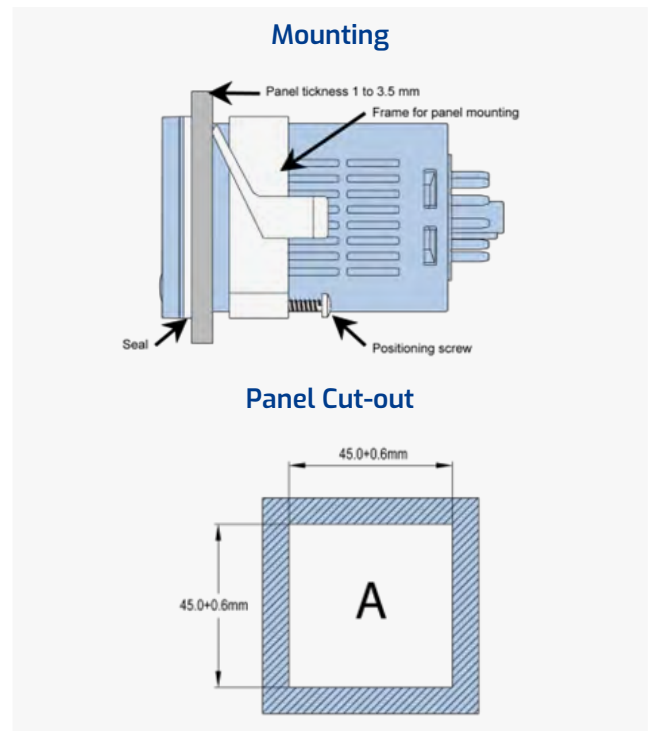
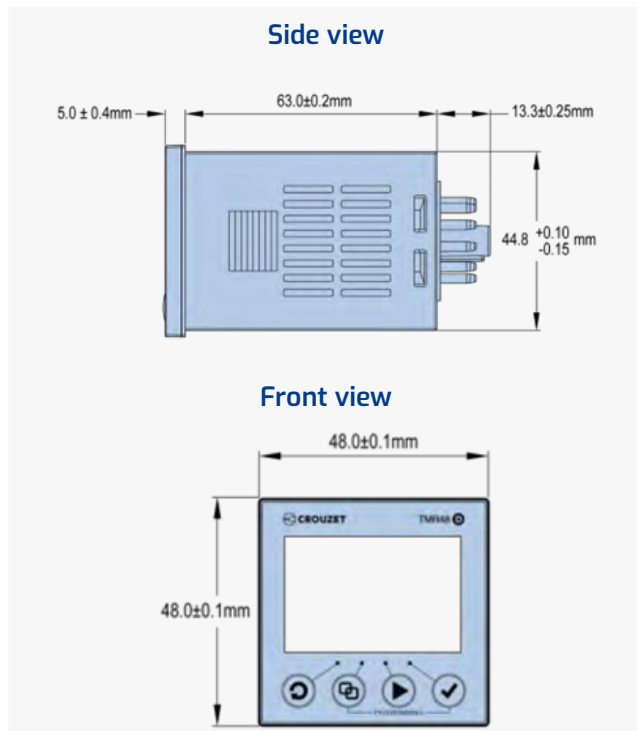

**Accessories**

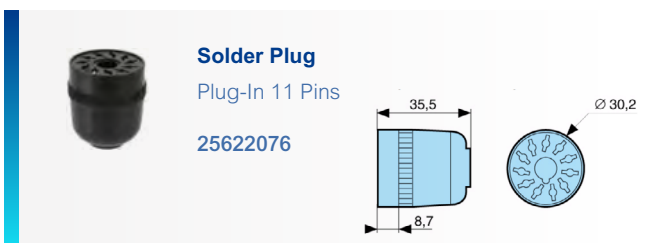
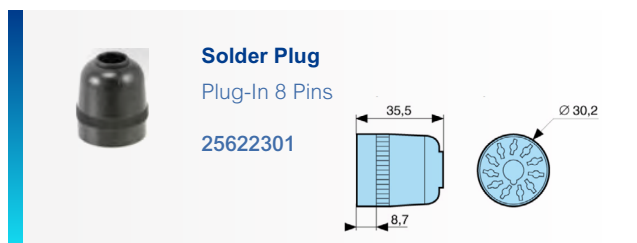
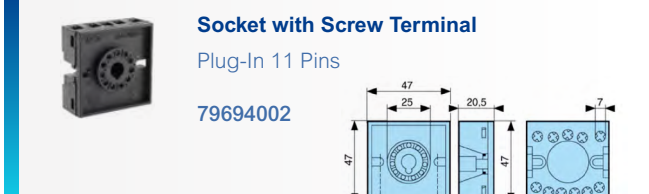
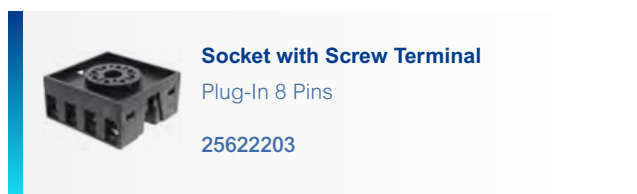
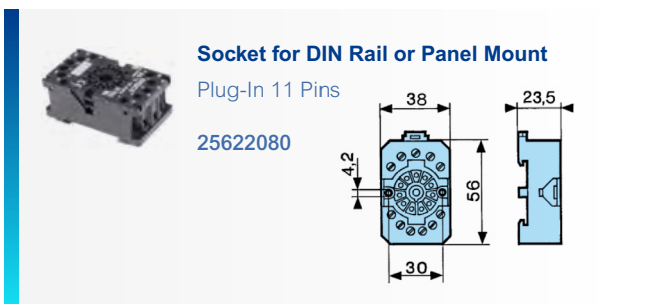
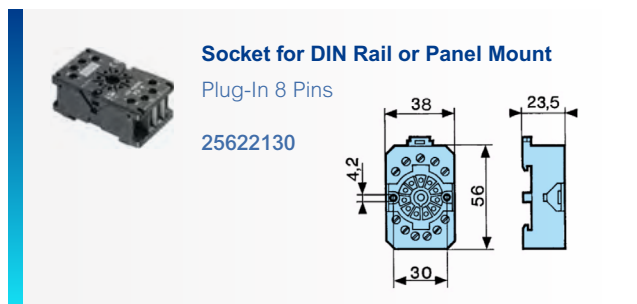

**Function diagrams**

**Function A: On-Delay (Delay on make)**

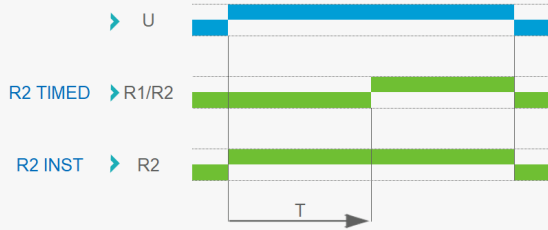

**Function Ab: Delayed Interval**

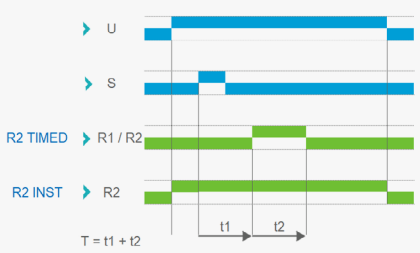

**Function At: Summation Time Relay**

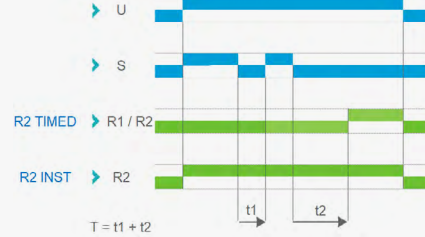

**Function B: One-Shot**

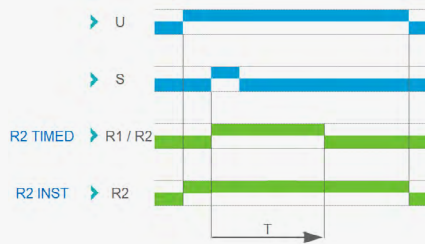

**Function Ac: On/Off Delay (Delay on make/break)**

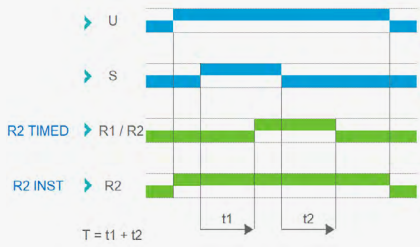

**Function C: Off-Delay (Delay on brake)**

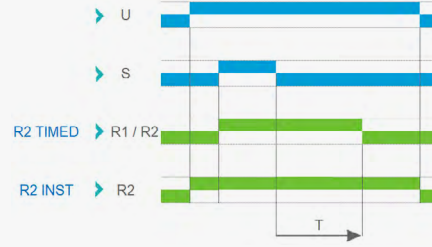

**Function Ad: Delay on Start**

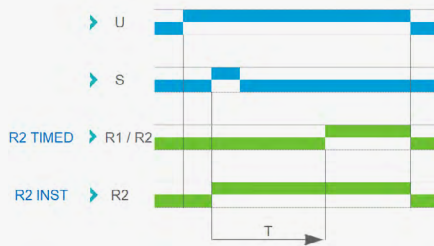

**Function D: Flasher (Symmetrical) - OFF Start**

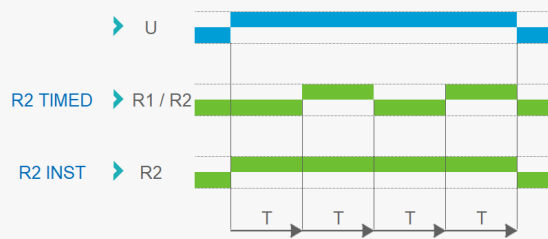

**Function AMt: On-Delay (Delay on make, Total memory: one delay)**

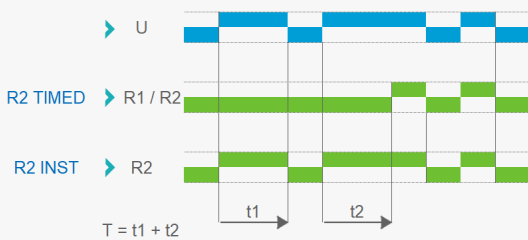

**Function Di: Flasher (Symmetrical) - ON Start**

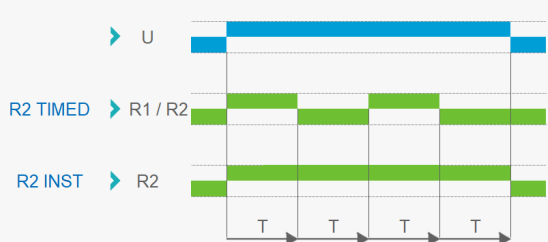

## Function diagrams

### Function H: Interval

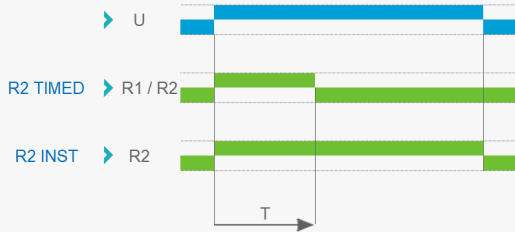

### Function Ht: interval summation time relay

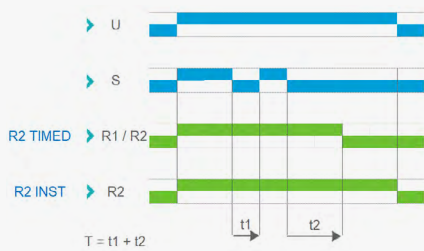

### Function L: Recycler (OFF Start)

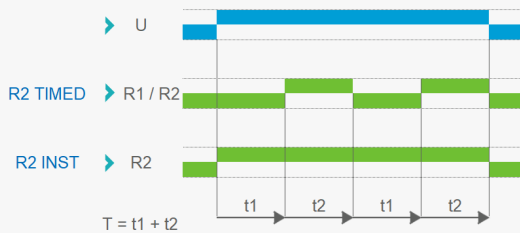

### Function Li: Recycler (ON Start)

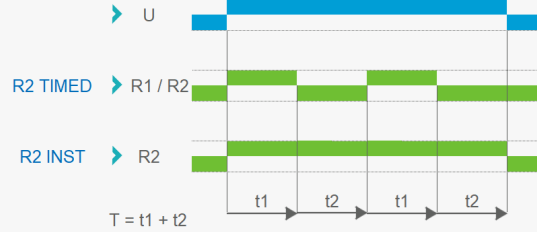

### Function T: On-Delay (Delay on make): sum of times

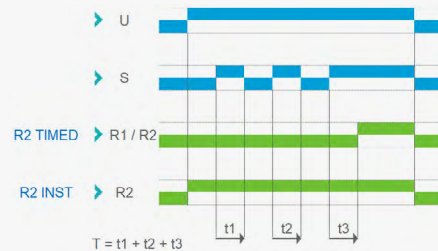

### Function W: Timing after pulse of control contact

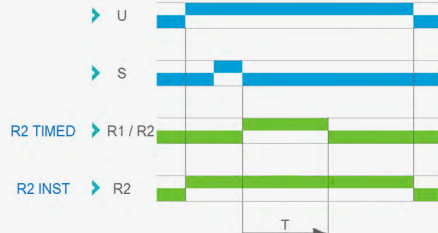

**Key functions**

Set time

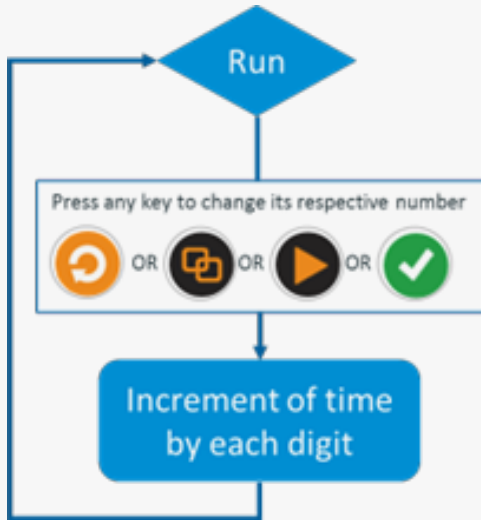

Reset time

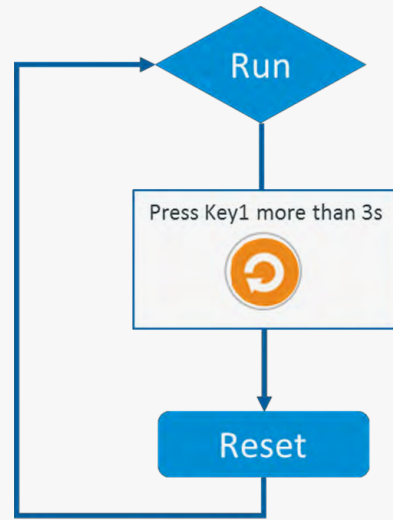

Check configured time and function

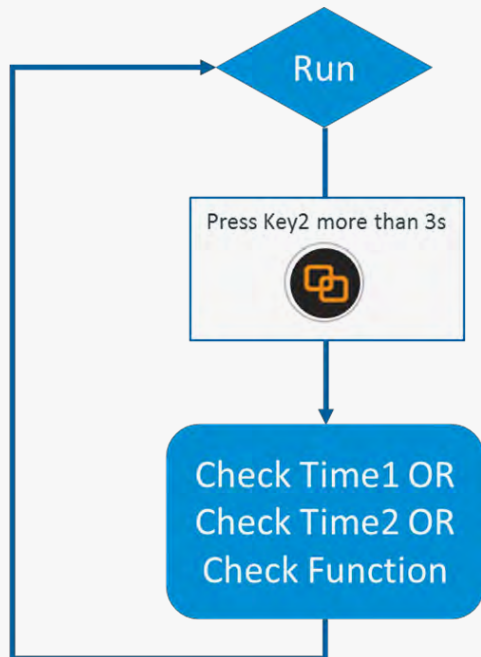

Programming mode

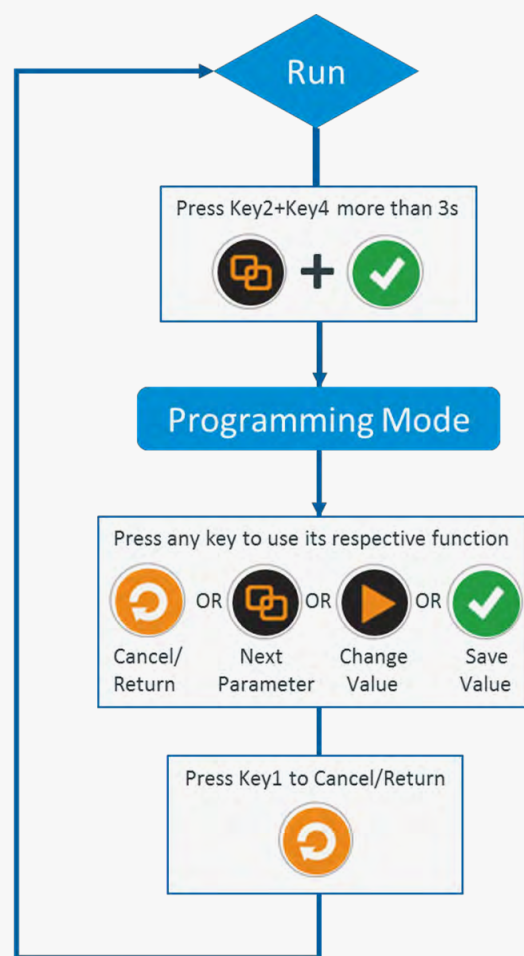

## Programming mode

### Programming main menu

#	Parameter	Value
1	<b>PASS</b> Pass If "Lock" function is on, pass needs to be entered	0000 0000
2	<b>bASIC_ProG</b> Basic Prog Enter to Basic Programming Mode	
3	<b>AdVAnCED_ProG</b> Advanced Prog Enter to Advanced Programming Mode	
4	<b>tEst</b> Test Enter to Test Mode	

### Basic programming menu

#	Parameter	Value
1	<b>FUncti on</b> Function Select the timing function	A Ab AC Ad ANt At b C A Ab Ac Ad AMt At B C H Ht L Li d di t ũ H Ht L Li D Di T W
2	<b>tI NE_rAnGE</b> Time Range Select the timing range	-.---s --.---s ---.---s ----s ---m---s ---s ---s ---s ---s ---m-s ---.m ---m ---h---m ---.h ---h ---m ---m -h-m ---h ---h
3	<b>CoUnt</b> Count Select the timing count up or down	UP Down Up Down
4	<b>MEmory</b> Memory Activate memory option (save timing after power off)	off on Off On
5	<b>oUtP Ut_2</b> Output 2 Select if Out 2 works timed or instantaneous (MDA2, GDS2)	tI NE i nSt Timed Instantaneous

## Programming mode

### Advanced programming menu

#	Parameter	Value
1	<b>I N P U T _ T I M E</b> Input Time Select input time wave	<b>0020s 0001s</b> 0.020s 0.001s
2	<b>I N P U T _ T Y P E</b> Input Type Select input to work with a NPN or PNP signal	<b>P n P n P n</b> PNP NPN
3	<b>T I M E _ L I M I T</b> Time Limit Select upper time limit	<b>9999 0000</b> 9999 0000
4	<b>b r i g h t n e s s</b> Brightness Select screen brightness	<b>100 50</b> 100% 50%
5	<b>S L E E P _ A F T E R</b> Sleep After Select the time needed to turn off the screen	<b>o f f 5 s 10 s 30 s 60 s</b> Off 5s 10s 30s 60s
6	<b>L o c k</b> Lock Select security level 1 (lock configuration) or 2 (lock all)	<b>o f f 1 2</b> Off 1 2
6.1	<b>P A S S</b> Pass Set password for lock option	<b>0000</b> 0000
6.2	<b>d o n e</b> Done Indication that the lock is on	
7	<b>d E F A U L T _ S E T T I N G S</b> Default Settings Reset settings to default values	<b>n o Y E S</b> No Yes
7.1	<b>S U R E</b> Sure Confirm if reset settings to default values	<b>n o Y E S</b> No Yes
7.2	<b>d o n e</b> Done Indication that settings have been reset	

### Test mode menu

#	Parameter	Value
1	<b>o U T 1</b> Out 1 Turn on/off Relay Output 1	<b>o f f o n</b> Off On
2	<b>o U T 2</b> Out 2 Turn on/off Relay Output 2 (MDA2, GDS2)	<b>o f f o n</b> Off On
3	<b>d I S P L A Y</b> Display Turn on/off all display segments	<b>o f f o n</b> Off On
4	<b>M E M O R Y</b> Memory Test the memory of the timer	<b>o f f t E S T</b> Off Test
4.1	<b>G o o d</b> Good Indication that the memory is working properly	
4.2	<b>E r r .</b> Error Indication that the memory is not working property	

**Wiring diagrams**

**MDA2R10MV2**

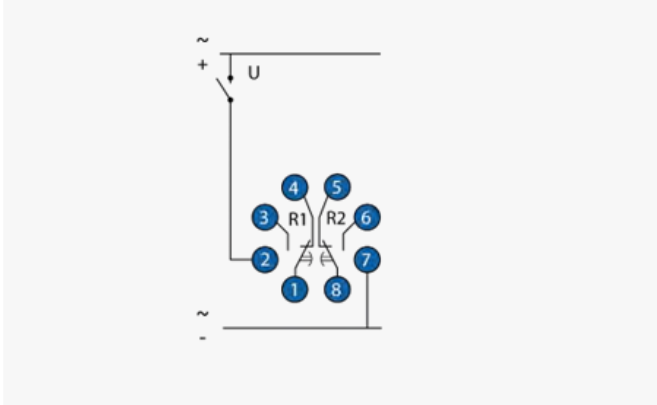

**MDF1R10MV2**

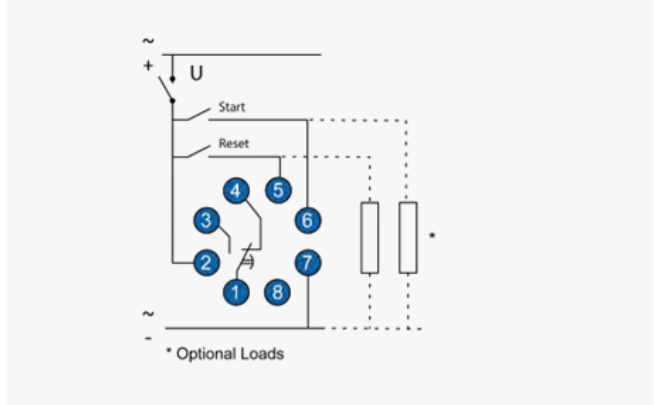

**GDF1R10MV2**

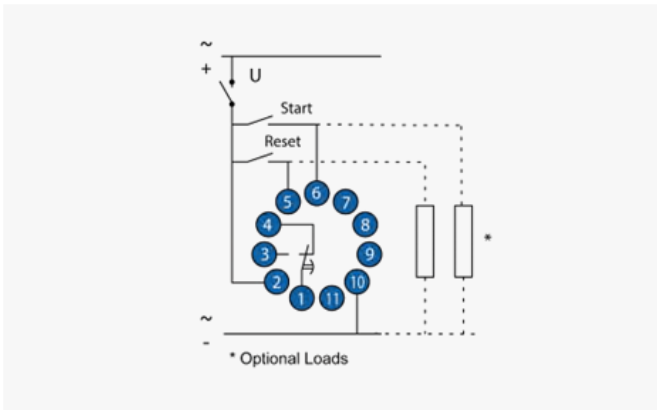

**GDS2R10MV2**

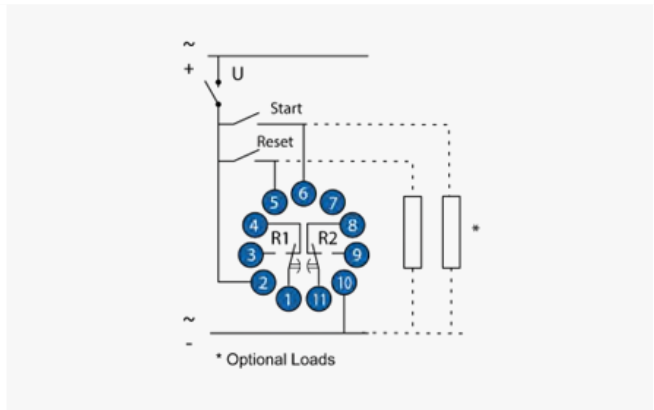

**WARNING** - The product information contained in this catalogue is given purely as information and does not constitute a representation, warranty or any form of contractual commitment. Crouzet Automatismes SAS and its subsidiaries reserve the right to modify their products without notice. It is imperative that we should be consulted over any particular use or application of our products and it is the responsibility of the buyer to establish, particularly through all the appropriate tests, that the product is suitable for the use or application. Under no circumstances will our warranty apply, nor shall we be held responsible for any application (such as any modification, addition, deletion, use in conjunction with other electrical or electronic components, circuits or assemblies, or any other unsuitable material or substance) which has not been expressly agreed by us prior to the sale of our products.

## Looking for pricing, stock, or lifecycle information?

Click below to explore more details on WIN SOURCE:

 [View 25622130 on WIN SOURCE](#)

 [Crouzet USA](#) Information

## Optimize Your Supply Chain with WIN SOURCE Solutions

-  Global Sourcing Solution
-  Obsolete Management
-  Cost Control Management
-  Shortage Management
-  Alternative Solution
-  Excess Inventory Management