



# THE DATASHEET OF FXLP34FHX



# Single Bit Uni-Directional Translator

## FXLP34

### Description

The FXLP34 is a single translator with two separate supply voltages:  $V_{CC1}$  for input translation voltages and  $V_{CC}$  for output translation voltages. The FXLP34 is part of onsemi's Ultra Low Power (ULP) series of products. This device operates with VCC values from 1.0 V to 3.6 V, and is intended for use in portable applications that require ultra low power consumption.

The internal circuit is composed of a minimum of buffer stages, to enable ultra low dynamic power.

The FXLP34 is uniquely designed for optimized power and speed, and is fabricated with an advanced CMOS technology to achieve high-speed operation while maintaining low CMOS power dissipation.

### Features

- 1.0 V to 3.6 V  $V_{CC}$  Supply Voltage
- Converts Any Voltage (1.0 V to 3.6 V) to (1.0 V to 3.6 V)
- 4.6V Tolerant Inputs and Outputs
- $t_{PD}$ :
  - ◆ 4 ns Typical for 3.0 V to 3.6 V  $V_{CC}$
- Power-Off High Impedance Inputs and Outputs
- Static Drive ( $I_{OH}/I_{OL}$ ):
  - ◆  $\pm 2.6$  mA at 3.00 V  $V_{CC}$
- Uses Proprietary Quiet Series Noise / EMI Reduction Circuitry
- Ultra-Small MicroPak™ Leadless Packages
- Ultra-Low Dynamic Power
- These are Pb-Free Devices



SIP6 1.45X1.0  
CASE 127EB

### MARKING DIAGRAM

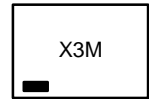

UDFN6  
1.0X1.0, 0.35P  
CASE 517DP

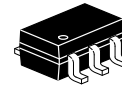
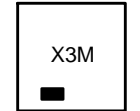

SC-88A (SC-70  
5 Lead), 1.25x2  
CASE 419AC-01

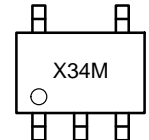

X3, X34 = Device Code  
 M = Assembly Operation Month

### ORDERING INFORMATION

See detailed ordering and shipping information on page 9 of this data sheet.

# FXLP34

## PIN CONFIGURATION

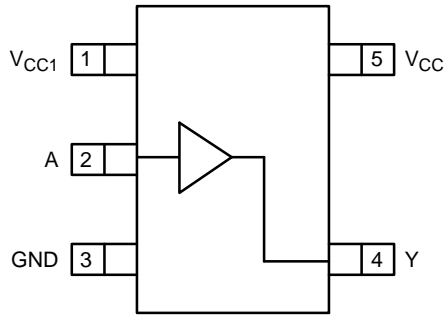

Figure 1. SC70 (Top View)

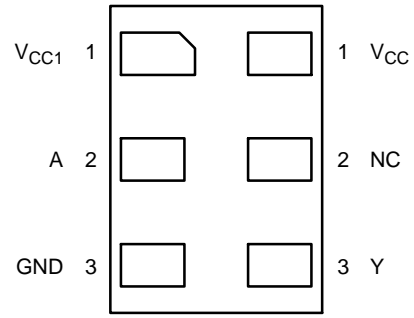

Figure 2. MicroPak (Top Through View)

### PIN DEFINITIONS

Pin # SC70	Pin # MicroPak	Name	Description
1	1	Vcc1	Input Translation Voltage
2	2	A	Input
3	3	GND	Ground
4	4	Y	Output
	5	NC	No Connect
5	6	Vcc	Output Translation Voltage

### TRUTH TABLE

Input	Outputs
A	Y
L	L
H	H

H = Logic Level HIGH  
L = Logic Level Low

# FXLP34

## ABSOLUTE MAXIMUM RATINGS

Symbol	Parameter		Min	Max	Unit
V <sub>CC</sub> , V <sub>CC1</sub>	Supply Voltage		-0.5	+4.6	V
V <sub>IN</sub>	DC Input Voltage		-0.5	+4.6	V
V <sub>OUT</sub>	DC Output Voltage	HIGH or LOW State (Note 1)	-0.5	V <sub>CC</sub> + 0.5 V	V
		V <sub>CC</sub> = 0 V	-0.5	+4.6	
I <sub>IK</sub>	DC Input Diode Current	V <sub>IN</sub> < 0	-	-50	mA
I <sub>OK</sub>	DC Output Diode Current	V <sub>OUT</sub> < 0 V	-	-50	mA
		V <sub>OUT</sub> > V <sub>CC</sub>	-	+50	
I <sub>OH</sub> /I <sub>OL</sub>	DC Output Source/Sink Current		-	±50	mA
I <sub>CC</sub> or I <sub>GND</sub>	DC V <sub>CC</sub> or Ground Current per Supply Pin		-	±100	mA
T <sub>STG</sub>	Storage Temperature Range		-65	150	°C
P <sub>D</sub>	Power Dissipation at +85°C	SC70-6	-	180	mW
		MicroPak™-6	-	130	
		MicroPak2™-6	-	120	
ESD	Human Body Model, JEDEC:JESD22-A114		-	4000	V
	Charge Device Model, JEDEC:JESD22-C101		-	2000	

Stresses exceeding those listed in the Maximum Ratings table may damage the device. If any of these limits are exceeded, device functionality should not be assumed, damage may occur and reliability may be affected.

1. I<sub>O</sub> Absolute Maximum Rating must be observed.

## RECOMMENDED OPERATING CONDITIONS

Symbol	Parameter	Conditions	Min	Max	Unit
V <sub>CC</sub> , V <sub>CC1</sub>	Supply Voltage		1.0	3.6	V
V <sub>IN</sub>	Input Voltage		0	3.6	V
V <sub>OUT</sub>	Output Voltage	HIGH or LOW State	0	V <sub>CC</sub>	V
		V <sub>CC</sub> = 0 V	0	3.6	
I <sub>OH</sub> /I <sub>OL</sub>	Output Current in I <sub>OH</sub> /I <sub>OL</sub>	V <sub>CC</sub> = 3.0 to 3.6 V	-	±2.6	mA
		V <sub>CC</sub> = 2.3 to 2.7 V	-	±2.1	
		V <sub>CC</sub> = 1.65 to 1.95 V	-	±1.5	
		V <sub>CC</sub> = 1.40 to 1.60 V	-	±1.0	
		V <sub>CC</sub> = 1.10 to 1.30 V	-	±0.5	
		V <sub>CC</sub> = 1.0 V	-	±20	μA
T <sub>A</sub>	Operating Temperature, Free Air		-40	+85	°C
θ <sub>JA</sub>	Thermal Resistance	SC70-6	-	425	°C/W
		MicroPak-6	-	500	
		MicroPak2-6	-	560	

Functional operation above the stresses listed in the Recommended Operating Ranges is not implied. Extended exposure to stresses beyond the Recommended Operating Ranges limits may affect device reliability.

2. Unused inputs must be held HIGH or LOW. They may not float.

# FXLP34

## ELECTRICAL CHARACTERISTICS

Symbol	Parameter	Condition	V <sub>CC</sub> (V)	V <sub>CC1</sub> (V)	T <sub>A</sub> = +25°C		T <sub>A</sub> = -40 to 85°C		Unit
					Min	Max	Min	Max	
V <sub>IH</sub>	HIGH Level Input (V <sub>CC1</sub> )		1.0 to 3.6	1.0	0.65 x V <sub>CC1</sub>	-	0.65 x V <sub>CC1</sub>	-	V
				1.10 ≤ V <sub>CC1</sub> ≤ 1.30	0.65 x V <sub>CC1</sub>	-	0.65 x V <sub>CC1</sub>	-	
				1.40 ≤ V <sub>CC1</sub> ≤ 1.60	0.65 x V <sub>CC1</sub>	-	0.65 x V <sub>CC1</sub>	-	
				1.65 ≤ V <sub>CC1</sub> ≤ 1.95	0.65 x V <sub>CC1</sub>	-	0.65 x V <sub>CC1</sub>	-	
				2.30 ≤ V <sub>CC1</sub> ≤ 2.70	1.6	-	1.6	-	
				3.00 ≤ V <sub>CC1</sub> ≤ 3.60	2.1	-	2.1	-	
V <sub>IL</sub>	LOW Level Input (V <sub>CC1</sub> )		1.0 to 3.6	1.0	-	0.35 x V <sub>CC1</sub>	-	0.35 x V <sub>CC1</sub>	V
				1.10 ≤ V <sub>CC1</sub> ≤ 1.30	-	0.35 x V <sub>CC1</sub>	-	0.35 x V <sub>CC1</sub>	
				1.40 ≤ V <sub>CC1</sub> ≤ 1.60	-	0.35 x V <sub>CC1</sub>	-	0.35 x V <sub>CC1</sub>	
				1.65 ≤ V <sub>CC1</sub> ≤ 1.95	-	0.35 x V <sub>CC1</sub>	-	0.35 x V <sub>CC1</sub>	
				2.30 ≤ V <sub>CC1</sub> ≤ 2.70	-	0.7	-	0.7	
				3.00 ≤ V <sub>CC1</sub> ≤ 3.60	-	0.9	-	0.9	
V <sub>OH</sub>	HIGH Level Output (V <sub>CC</sub> )	I <sub>OH</sub> = -20 μA	1.0	1.0 to 3.6	V <sub>CC</sub> - 0.1	-	V <sub>CC</sub> - 0.1	-	V
			1.10 ≤ V <sub>CC1</sub> ≤ 1.30		V <sub>CC</sub> - 0.1	-	V <sub>CC</sub> - 0.1	-	
			1.40 ≤ V <sub>CC1</sub> ≤ 1.60		V <sub>CC</sub> - 0.1	-	V <sub>CC</sub> - 0.1	-	
			1.65 ≤ V <sub>CC1</sub> ≤ 1.95		V <sub>CC</sub> - 0.1	-	V <sub>CC</sub> - 0.1	-	
			2.30 ≤ V <sub>CC1</sub> ≤ 2.70		V <sub>CC</sub> - 0.1	-	V <sub>CC</sub> - 0.1	-	
			3.00 ≤ V <sub>CC1</sub> ≤ 3.60		V <sub>CC</sub> - 0.1	-	V <sub>CC</sub> - 0.1	-	
		I <sub>OH</sub> = -0.5 mA	1.10 ≤ V <sub>CC1</sub> ≤ 1.30	1.0 to 3.6	0.75 x V <sub>CC</sub>	-	0.70 x V <sub>CC</sub>	-	
		I <sub>OH</sub> = -1.0 mA	1.40 ≤ V <sub>CC1</sub> ≤ 1.60		1.07	-	0.99	-	
		I <sub>OH</sub> = -1.5 mA	1.65 ≤ V <sub>CC1</sub> ≤ 1.95		1.24	-	1.22	-	
		I <sub>OH</sub> = -2.1 mA	2.30 ≤ V <sub>CC1</sub> ≤ 2.70		1.95	-	1.87	-	
		I <sub>OH</sub> = -2.6 mA	3.00 ≤ V <sub>CC1</sub> ≤ 3.60		2.61	-	2.55	-	
V <sub>OL</sub>	LOW Level Output (V <sub>CC</sub> )	I <sub>OL</sub> = 20 μA	1.0	1.0 to 3.6	-	0.1	-	0.1	V
			1.10 ≤ V <sub>CC1</sub> ≤ 1.30		-	0.1	-	0.1	
			1.40 ≤ V <sub>CC1</sub> ≤ 1.60		-	0.1	-	0.1	
			1.65 ≤ V <sub>CC1</sub> ≤ 1.95		-	0.1	-	0.1	
			2.30 ≤ V <sub>CC1</sub> ≤ 2.70		-	0.1	-	0.1	
		I <sub>OL</sub> = 0.5 mA	1.10 ≤ V <sub>CC1</sub> ≤ 1.30	1.0 to 3.6	-	0.30 x V <sub>CC</sub>	-	0.30 x V <sub>CC</sub>	
		I <sub>OL</sub> = 1.0 mA	1.40 ≤ V <sub>CC1</sub> ≤ 1.60		-	0.31	-	0.37	
		I <sub>OL</sub> = 1.5 mA	1.65 ≤ V <sub>CC1</sub> ≤ 1.95		-	0.31	-	0.35	
		I <sub>OL</sub> = 2.1 mA	2.30 ≤ V <sub>CC1</sub> ≤ 2.70		-	0.31	-	0.33	
		I <sub>OL</sub> = 2.6 mA	3.00 ≤ V <sub>CC1</sub> ≤ 3.60		-	0.31	-	0.33	
I <sub>IN</sub>	Input Leakage Current	0 ≤ V <sub>IN</sub> ≤ 3.60		1.0 to 3.6	-	±0.1	-	±1.0	μA
I <sub>OFF</sub>	Power Off Leakage Current	0 ≤ (V <sub>IN</sub> , V <sub>O</sub> ) ≤ 3.60	0	0	-	1.0	-	5.0	μA
I <sub>CC</sub>	Quiescent Supply Current	V <sub>IN</sub> = V <sub>CC</sub> or GND	1.0 to 3.6	1.0 to 3.6	-	0.9	-	5.0	μA

Product parametric performance is indicated in the Electrical Characteristics for the listed test conditions, unless otherwise noted. Product performance may not be indicated by the Electrical Characteristics if operated under different conditions.

# FXLP34

## AC ELECTRICAL CHARACTERISTICS

Symbol	Parameter	Condition	V <sub>CC</sub> (V)	T <sub>A</sub> = +25°C			T <sub>A</sub> = -40 to 85°C		Unit	Figure
				Min	Typ	Max	Min	Max		
t <sub>PHL</sub> , t <sub>PLH</sub>	Propagation Delay Output Translation V <sub>CC</sub> (V) = 1.0	C <sub>L</sub> = 10 pF, R <sub>L</sub> = 1 MΩ	1.0	-	26.0	-	-	-	ns	Figure 3, Figure 4
			1.10 to 1.30	15.0	25.0	38.1	12.0	43.3		
			1.40 to 1.60	14.0	24.0	36.7	11.0	42.0		
			1.65 to 1.95	13.0	23.0	36.0	10.0	41.4		
			2.30 to 2.70	12.0	22.0	35.5	9.0	40.9		
			3.00 to 3.60	11.0	21.0	35.5	8.0	40.6		
t <sub>PHL</sub> , t <sub>PLH</sub>	Propagation Delay Output Translation V <sub>CC</sub> (V) = 1.2	C <sub>L</sub> = 10 pF, R <sub>L</sub> = 1 MΩ	1.0	-	18.0	-	-	-	ns	Figure 3, Figure 4
			1.10 to 1.30	8.0	15.0	23.2	6.0	41.0		
			1.40 to 1.60	7.5	14.0	21.7	5.5	39.1		
			1.65 to 1.95	7.0	13.0	20.9	5.0	32.3		
			2.30 to 2.70	6.5	12.0	20.4	4.5	29.6		
			3.00 to 3.60	6.0	12.0	20.2	4.0	29.4		
t <sub>PHL</sub> , t <sub>PLH</sub>	Propagation Delay Output Translation V <sub>CC</sub> (V) = 1.5	C <sub>L</sub> = 10 pF, R <sub>L</sub> = 1 MΩ	1.0	-	14.0	-	-	-	ns	Figure 3, Figure 4
			1.10 to 1.30	5.0	11.0	16.3	4.0	20.6		
			1.40 to 1.60	4.8	10.0	14.8	3.5	19.3		
			1.65 to 1.95	4.5	9.0	14.1	3.0	18.7		
			2.30 to 2.70	4.0	8.0	13.5	2.5	18.0		
			3.00 to 3.60	3.5	8.0	13.3	2.0	17.8		
t <sub>PHL</sub> , t <sub>PLH</sub>	Propagation Delay Output Translation V <sub>CC</sub> (V) = 1.8	C <sub>L</sub> = 10 pF, R <sub>L</sub> = 1 MΩ	1.0	-	13.0	-	-	-	ns	Figure 3, Figure 4
			1.10 to 1.30	4.0	9.0	13.5	3.0	17.5		
			1.40 to 1.60	3.5	8.0	12.0	2.5	16.3		
			1.65 to 1.95	3.0	7.0	11.3	2.0	15.6		
			2.30 to 2.70	2.5	6.0	10.7	1.5	15.0		
			3.00 to 3.60	2.5	6.0	10.5	1.0	14.7		
t <sub>PHL</sub> , t <sub>PLH</sub>	Propagation Delay Output Translation V <sub>CC</sub> (V) = 2.5	C <sub>L</sub> = 10 pF, R <sub>L</sub> = 1 MΩ	1.0	-	12.0	-	-	-	ns	Figure 3, Figure 4
			1.10 to 1.30	3.0	7.0	10.9	2.5	14.3		
			1.40 to 1.60	2.5	6.0	9.4	2.0	13.1		
			1.65 to 1.95	2.0	5.0	8.6	1.5	11.4		
			2.30 to 2.70	1.5	4.0	8.0	1.0	10.8		
			3.00 to 3.60	1.5	4.0	7.8	1.0	10.5		
t <sub>PHL</sub> , t <sub>PLH</sub>	Propagation Delay Output Translation V <sub>CC</sub> (V) = 3.3	C <sub>L</sub> = 10 pF, R <sub>L</sub> = 1 MΩ	1.0	-	11.0	-	-	-	ns	Figure 3, Figure 4
			1.10 to 1.30	3.0	6.0	10.1	2.0	13.8		
			1.40 to 1.60	2.5	5.0	8.2	1.5	10.5		
			1.65 to 1.95	2.0	4.0	7.4	1.0	9.9		
			2.30 to 2.70	1.0	3.0	6.8	1.0	9.2		
			3.00 to 3.60	1.0	3.0	6.6	1.0	9.0		

# FXLP34

## AC ELECTRICAL CHARACTERISTICS (continued)

Symbol	Parameter	Condition	V <sub>CC</sub> (V)	T <sub>A</sub> = +25°C			T <sub>A</sub> = -40 to 85°C		Unit	Figure
				Min	Typ	Max	Min	Max		
t <sub>PHL</sub> , t <sub>PLH</sub>	Propagation Delay Output Translation V <sub>CC</sub> (V) = 1.0	C <sub>L</sub> = 15 pF, R <sub>L</sub> = 1 MΩ	1.0	-	28.0	-	-	-	ns	Figure 3, Figure 4
			1.10 to 1.30	16.0	27.0	43.0	12.0	44.8		
			1.40 to 1.60	15.0	26.0	41.6	11.0	43.6		
			1.65 to 1.95	14.0	25.0	40.9	10.0	47.9		
			2.30 to 2.70	13.0	24.0	40.5	9.0	47.5		
			3.00 to 3.60	12.0	23.0	40.4	8.0	41.4		
t <sub>PHL</sub> , t <sub>PLH</sub>	Propagation Delay Output Translation V <sub>CC</sub> (V) = 1.2	C <sub>L</sub> = 15 pF, R <sub>L</sub> = 1 MΩ	1.0	-	19.0	-	-	-	ns	Figure 3, Figure 4
			1.10 to 1.30	9.0	16.0	24.6	8.0	43.1		
			1.40 to 1.60	8.5	15.0	23.1	7.5	42.2		
			1.65 to 1.95	8.0	14.0	22.4	7.0	31.4		
			2.30 to 2.70	7.5	13.0	21.8	6.5	30.7		
			3.00 to 3.60	7.0	13.0	21.6	6.0	30.5		
t <sub>PHL</sub> , t <sub>PLH</sub>	Propagation Delay Output Translation V <sub>CC</sub> (V) = 1.5	C <sub>L</sub> = 15 pF, R <sub>L</sub> = 1 MΩ	1.0	-	15.0	-	-	-	ns	Figure 3, Figure 4
			1.10 to 1.30	6.0	12.0	17.2	5.5	21.5		
			1.40 to 1.60	5.8	11.0	15.7	5.0	20.3		
			1.65 to 1.95	5.5	10.0	14.9	4.5	19.6		
			2.30 to 2.70	5.0	9.0	14.3	4.0	18.9		
			3.00 to 3.60	4.5	.0	14.2	3.5	18.7		
t <sub>PHL</sub> , t <sub>PLH</sub>	Propagation Delay Output Translation V <sub>CC</sub> (V) = 1.8	C <sub>L</sub> = 15 pF, R <sub>L</sub> = 1 MΩ	1.0	-	14.0	-	-	-	ns	Figure 3, Figure 4
			1.10 to 1.30	5.0	8.0	14.2	5.5	18.2		
			1.40 to 1.60	4.5	7.0	12.7	4.0	17.0		
			1.65 to 1.95	4.0	6.0	11.9	3.5	16.3		
			2.30 to 2.70	3.5	5.0	11.3	3.0	15.7		
			3.00 to 3.60	3.5	5.0	11.2	2.5	14.4		
t <sub>PHL</sub> , t <sub>PLH</sub>	Propagation Delay Output Translation V <sub>CC</sub> (V) = 2.5	C <sub>L</sub> = 15 pF, R <sub>L</sub> = 1 MΩ	1.0	-	12.0	-	-	-	ns	Figure 3, Figure 4
			1.10 to 1.30	4.0	7.0	11.3	3.5	14.9		
			1.40 to 1.60	3.5	6.0	9.8	3.0	13.6		
			1.65 to 1.95	3.0	5.0	9.1	2.5	12.0		
			2.30 to 2.70	2.5	4.0	8.5	2.0	11.3		
			3.00 to 3.60	2.5	4.0	8.3	2.0	11.1		
t <sub>PHL</sub> , t <sub>PLH</sub>	Propagation Delay Output Translation V <sub>CC</sub> (V) = 3.3	C <sub>L</sub> = 15 pF, R <sub>L</sub> = 1 MΩ	1.0	-	11.0	-	-	-	ns	Figure 3, Figure 4
			1.10 to 1.30	3.0	6.0	10.5	2.0	14.2		
			1.40 to 1.60	2.5	5.0	8.6	1.5	11.0		
			1.65 to 1.95	2.0	4.0	7.8	1.0	10.3		
			2.30 to 2.70	1.5	3.0	7.2	1.0	9.7		
			3.00 to 3.60	1.5	3.0	7.0	1.0	9.4		

# FXLP34

## AC ELECTRICAL CHARACTERISTICS (continued)

Symbol	Parameter	Condition	V <sub>CC</sub> (V)	T <sub>A</sub> = +25°C			T <sub>A</sub> = -40 to 85°C		Unit	Figure
				Min	Typ	Max	Min	Max		
t <sub>PHL</sub> , t <sub>PLH</sub>	Propagation Delay Output Translation V <sub>CC</sub> (V) = 1.0	C <sub>L</sub> = 30 pF, R <sub>L</sub> = 1 MΩ	1.0	–	34.0	–	–	–	ns	Figure 3, Figure 4
			1.10 to 1.30	19.0	32.0	48.6	15.0	55.5		
			1.40 to 1.60	18.0	31.0	47.1	14.0	52.3		
			1.65 to 1.95	17.0	30.0	46.4	13.0	50.6		
			2.30 to 2.70	16.0	29.0	45.9	12.0	49.2		
			3.00 to 3.60	15.0	28.0	45.8	10.0	49.1		
t <sub>PHL</sub> , t <sub>PLH</sub>	Propagation Delay Output Translation V <sub>CC</sub> (V) = 1.2	C <sub>L</sub> = 30 pF, R <sub>L</sub> = 1 MΩ	1.0	–	22.0	–	–	–	ns	Figure 3, Figure 4
			1.10 to 1.30	11.0	19.0	29.0	10.0	46.5		
			1.40 to 1.60	10.0	18.0	27.5	9.0	42.6		
			1.65 to 1.95	9.0	17.0	26.7	8.0	36.7		
			2.30 to 2.70	8.5	16.0	26.1	7.0	36.0		
			3.00 to 3.60	8.0	16.0	26.0	6.0	35.9		
t <sub>PHL</sub> , t <sub>PLH</sub>	Propagation Delay Output Translation V <sub>CC</sub> (V) = 1.5	C <sub>L</sub> = 30 pF, R <sub>L</sub> = 1 MΩ	1.0	–	16.0	–	–	–	ns	Figure 3, Figure 4
			1.10 to 1.30	6.0	13.0	19.8	5.5	25.3		
			1.40 to 1.60	5.8	12.0	18.3	5.0	23.0		
			1.65 to 1.95	5.5	11.0	17.6	4.5	22.4		
			2.30 to 2.70	5.0	10.0	17.0	4.0	21.7		
			3.00 to 3.60	4.5	9.0	16.8	3.5	21.5		
t <sub>PHL</sub> , t <sub>PLH</sub>	Propagation Delay Output Translation V <sub>CC</sub> (V) = 1.8	C <sub>L</sub> = 30 pF, R <sub>L</sub> = 1 MΩ	1.0	–	15.0	–	–	–	ns	Figure 3, Figure 4
			1.10 to 1.30	5.0	11.0	16.2	5.5	20.4		
			1.40 to 1.60	4.5	10.0	14.7	4.0	19.2		
			1.65 to 1.95	4.0	9.0	13.9	3.5	18.5		
			2.30 to 2.70	3.5	8.0	13.3	3.0	17.9		
			3.00 to 3.60	3.5	8.0	13.1	2.5	17.6		
t <sub>PHL</sub> , t <sub>PLH</sub>	Propagation Delay Output Translation V <sub>CC</sub> (V) = 2.5	C <sub>L</sub> = 30 pF, R <sub>L</sub> = 1 MΩ	1.0	–	13.0	–	–	–	ns	Figure 3, Figure 4
			1.10 to 1.30	4.0	8.0	12.7	3.5	15.9		
			1.40 to 1.60	3.5	7.0	11.2	3.0	14.3		
			1.65 to 1.95	3.0	6.0	10.5	2.5	13.6		
			2.30 to 2.70	2.5	5.0	9.9	2.0	12.8		
			3.00 to 3.60	2.5	5.0	9.7	2.0	12.5		
t <sub>PHL</sub> , t <sub>PLH</sub>	Propagation Delay Output Translation V <sub>CC</sub> (V) = 3.3	C <sub>L</sub> = 30 pF, R <sub>L</sub> = 1 MΩ	1.0	–	12.0	–	–	–	ns	Figure 3, Figure 4
			1.10 to 1.30	3.0	8.0	11.7	2.0	15.0		
			1.40 to 1.60	2.5	7.0	9.8	1.5	12.2		
			1.65 to 1.95	2.0	6.0	8.9	1.0	11.5		
			2.30 to 2.70	1.5	5.0	8.3	1.0	10.7		
			3.00 to 3.60	1.5	5.0	8.1	1.0	10.4		

## CAPACITANCE

Symbol	Parameter	Conditions	V <sub>CC</sub> / V <sub>CC1</sub> (V)	T <sub>A</sub> = +25°C	Unit
				Typ	
C <sub>IN</sub>	Input Capacitance			2	pF
C <sub>I/O</sub>	Input/Output Capacitance			4	pF
C <sub>PD</sub>	Power Dissipation Capacitance	V <sub>I</sub> = 0 V or V <sub>CC1</sub> , f = 10 MHz, V <sub>CC</sub> / V <sub>CC1</sub> = 3.6 V	1.0 to 3.60	8	pF

## FXLP34

### Translator Power-up Sequence Recommendations

To ensure that the system does not experience unnecessary  $I_{CC}$  current draw, bus contention, or oscillations during power-up; adhere to the following guidelines. This device is designed with the output pin(s) supplied by  $V_{CC}$  and the input pin(s) supplied by  $V_{CC1}$ . The first recommendation is to begin by powering up the input side of the device with  $V_{CC1}$ . The Input pin(s) should be ramped with or ahead of  $V_{CC1}$  or held LOW. This guards against bus contentions and oscillations as all inputs and the

input  $V_{CC1}$  are powered at the same time. The output  $V_{CC}$  can then be powered to the target voltage level to which the device will translate. The output pin(s) then translate to logic levels dictated by the output  $V_{CC}$  levels.

Upon completion of these steps, the device can be configured for the desired operation. Following these steps helps prevent possible damage to the translator device as well as other system components

### AC Loadings and Waveforms

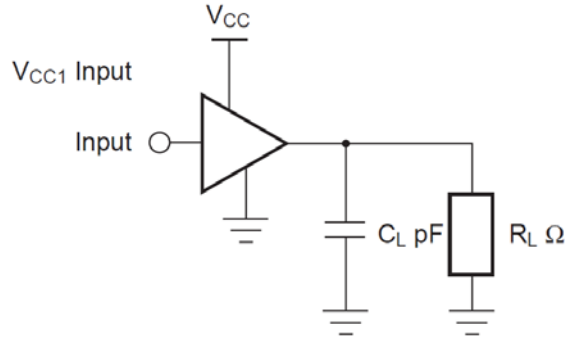

Figure 3. AC Test Circuit

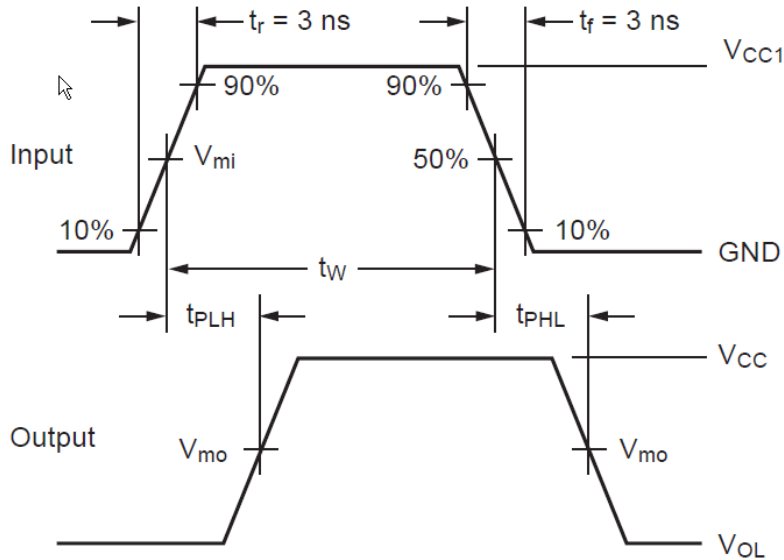

Figure 4. Waveform for Inverting and Non-Inverting Functions

Table 1. AC LOAD TABLE

Symbol	$V_{CC}$					
	3.3 V $\pm$ 0.3 V	2.5 V $\pm$ 0.2 V	1.8 V $\pm$ 0.15 V	1.5 V $\pm$ 0.10 V	1.2 V $\pm$ 0.10 V	1.0 V
$V_{mi}$	1.5V	$V_{CC1}/2$	$V_{CC1}/2$	$V_{CC1}/2$	$V_{CC1}/2$	$V_{CC1}/2$
$V_{mo}$	1.5V	$V_{CC}/2$	$V_{CC}/2$	$V_{CC}/2$	$V_{CC}/2$	$V_{CC}/2$

# FXLP34

## ORDERING INFORMATION

Part Number	Top Mark	Package Type	Shipping†
FXLP34P5X	X34	5-Lead SC70, EIAJ SC-88a, 1.25 mm Wide (Pb-Free)	3000 / Tape & Reel
FXLP34L6X	X3	SIP6, 6-Lead MicroPak, 1.00 mm Wide (Pb-Free)	5000 / Tape & Reel
FXLP34FHX	X3	UDFN6, 6-Lead, MicroPak2, 1x1 mm Body, .35 mm Pitch (Pb-Free)	5000 / Tape & Reel

†For information on tape and reel specifications, including part orientation and tape sizes, please refer to our Tape and Reel Packaging Specifications Brochure, BRD8011/D.

MicroPak and MicroPak2 are trademarks of Semiconductor Components Industries, LLC dba "onsemi" or its affiliates and/or subsidiaries in the United States and/or other countries.

SIP6 1.45X1.0  
CASE 127EB  
ISSUE O

DATE 31 AUG 2016

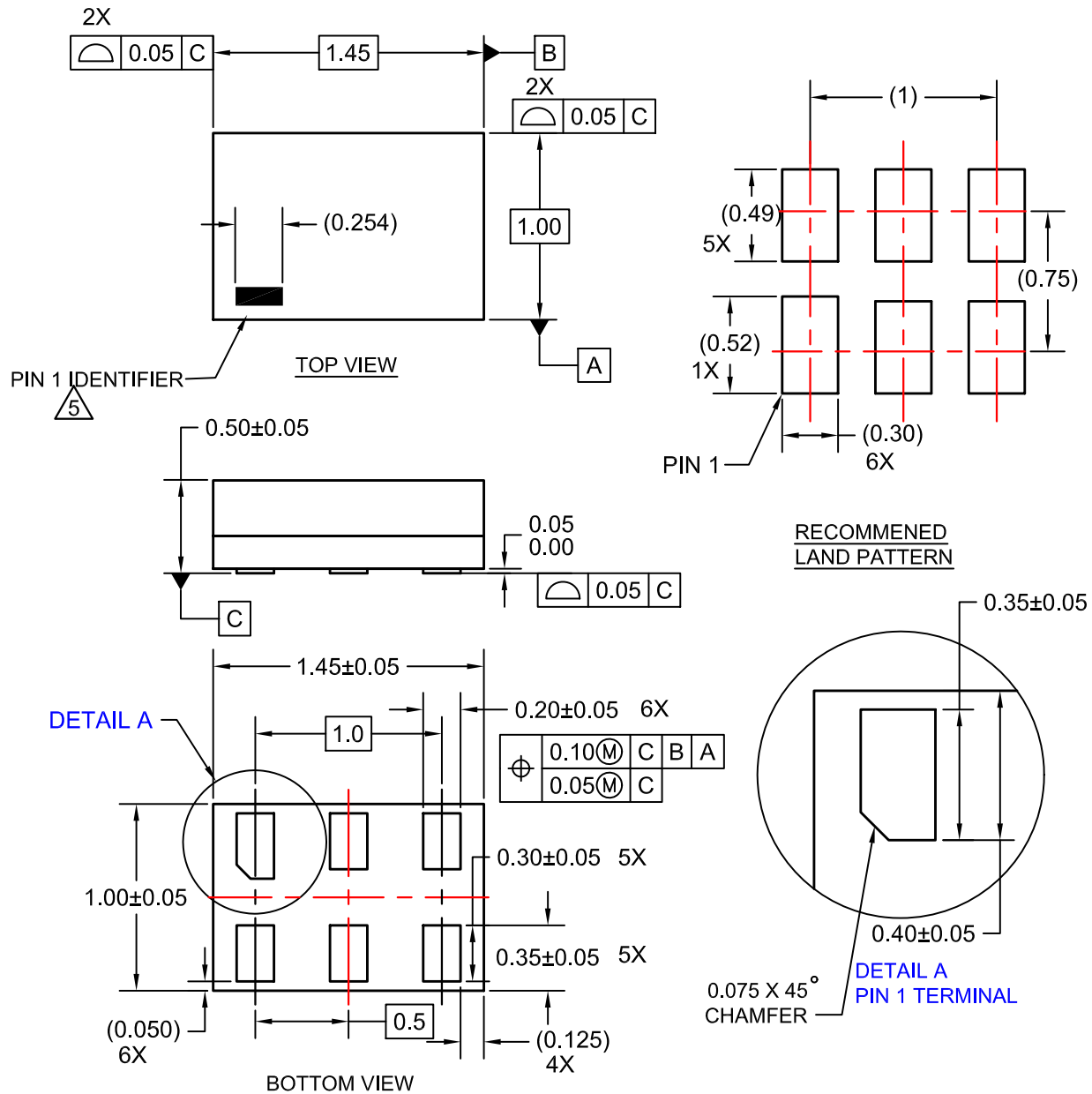

NOTES:

1. CONFORMS TO JEDEC STANDARD MO-252 VARIATION UAAD
2. DIMENSIONS ARE IN MILLIMETERS
3. DRAWING CONFORMS TO ASME Y14.5M-2009
4. PIN ONE IDENTIFIER IS 2X LENGTH OF ANY OTHER LINE IN THE MARK CODE LAYOUT.

<b>DOCUMENT NUMBER:</b>	<b>98AON13590G</b>	Electronic versions are uncontrolled except when accessed directly from the Document Repository. Printed versions are uncontrolled except when stamped "CONTROLLED COPY" in red.
<b>DESCRIPTION:</b>	<b>SIP6 1.45X1.0</b>	<b>PAGE 1 OF 1</b>

onsemi and ONSEMI are trademarks of Semiconductor Components Industries, LLC dba onsemi or its subsidiaries in the United States and/or other countries. onsemi reserves the right to make changes without further notice to any products herein. onsemi makes no warranty, representation or guarantee regarding the suitability of its products for any particular purpose, nor does onsemi assume any liability arising out of the application or use of any product or circuit, and specifically disclaims any and all liability, including without limitation special, consequential or incidental damages. onsemi does not convey any license under its patent rights nor the rights of others.

**SC-88A (SC-70 5 Lead), 1.25x2**  
CASE 419AC-01  
ISSUE A

DATE 29 JUN 2010

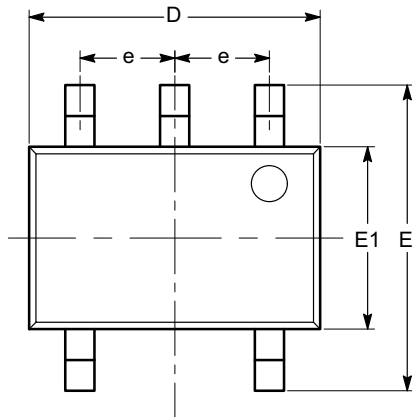

**TOP VIEW**

SYMBOL	MIN	NOM	MAX
A	0.80		1.10
A1	0.00		0.10
A2	0.80		1.00
b	0.15		0.30
c	0.10		0.18
D	1.80	2.00	2.20
E	1.80	2.10	2.40
E1	1.15	1.25	1.35
e	0.65 BSC		
L	0.26	0.36	0.46
L1	0.42 REF		
L2	0.15 BSC		
$\theta$	0°		8°
$\theta_1$	4°		10°

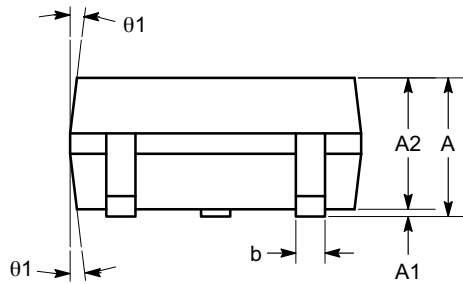

**SIDE VIEW**

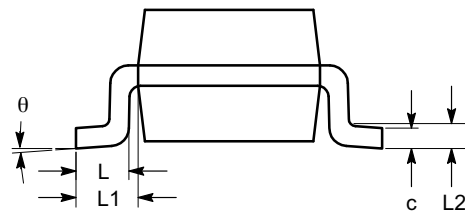

**END VIEW**

**Notes:**

- (1) All dimensions are in millimeters. Angles in degrees.
- (2) Complies with JEDEC MO-203.

<b>DOCUMENT NUMBER:</b>	<b>98AON34260E</b>	Electronic versions are uncontrolled except when accessed directly from the Document Repository. Printed versions are uncontrolled except when stamped "CONTROLLED COPY" in red.
<b>DESCRIPTION:</b>	<b>SC-88A (SC-70 5 LEAD), 1.25X2</b>	<b>PAGE 1 OF 1</b>

onsemi and Onsemi are trademarks of Semiconductor Components Industries, LLC dba onsemi or its subsidiaries in the United States and/or other countries. onsemi reserves the right to make changes without further notice to any products herein. onsemi makes no warranty, representation or guarantee regarding the suitability of its products for any particular purpose, nor does onsemi assume any liability arising out of the application or use of any product or circuit, and specifically disclaims any and all liability, including without limitation special, consequential or incidental damages. onsemi does not convey any license under its patent rights nor the rights of others.

**UDFN6 1.0X1.0, 0.35P**  
CASE 517DP  
ISSUE O

DATE 31 AUG 2016

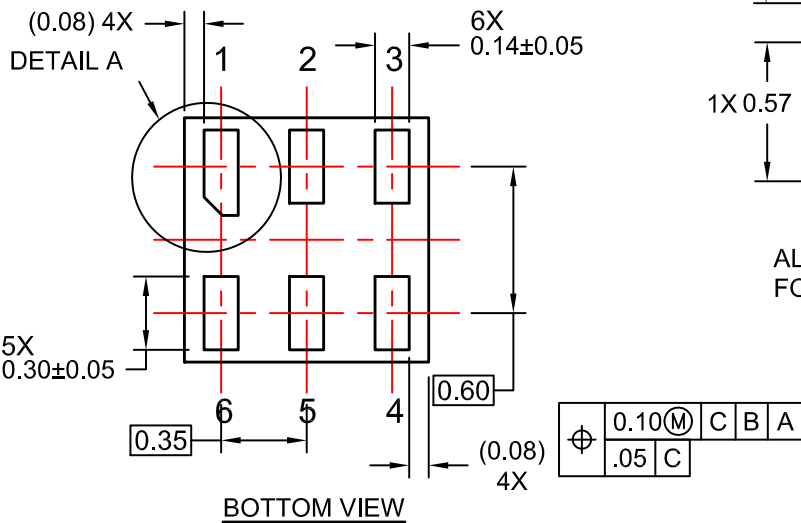
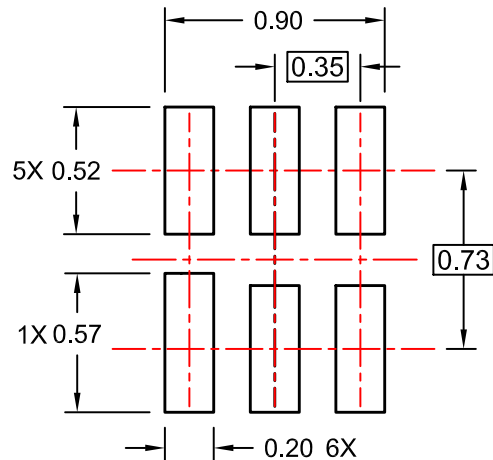
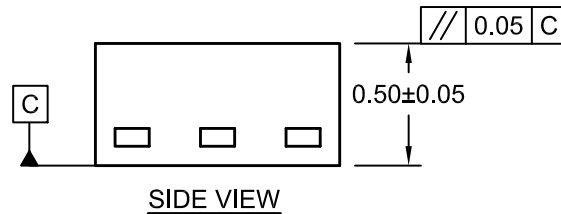
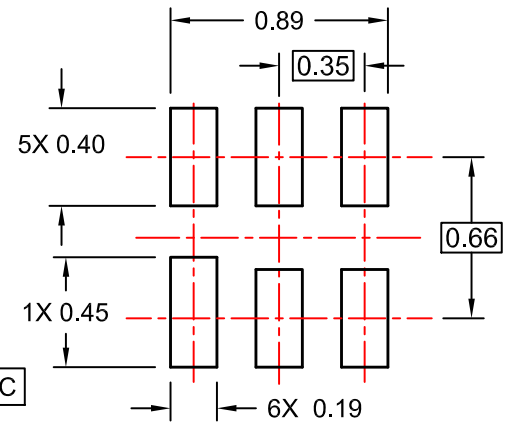
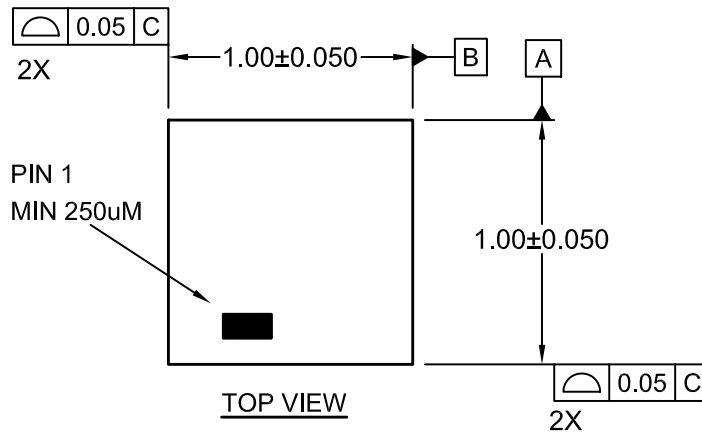

**ALTERNATIVE LAND PATTERN FOR UNIVERSAL APPLICATION**

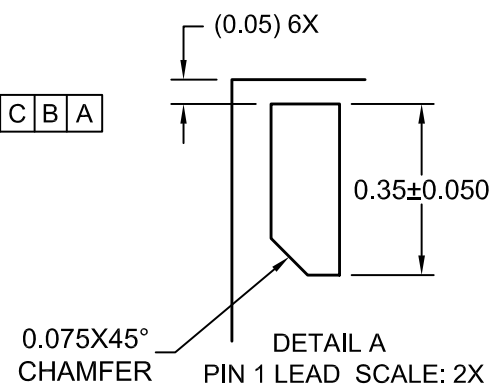

- NOTES:**
- A. COMPLIES TO JEDEC MO-252 STANDARD
  - B. DIMENSIONS ARE IN MILLIMETERS.
  - C. DIMENSIONS AND TOLERANCES PER ASME Y14.5M, 2009

<b>DOCUMENT NUMBER:</b>	<b>98AON13593G</b>	Electronic versions are uncontrolled except when accessed directly from the Document Repository. Printed versions are uncontrolled except when stamped "CONTROLLED COPY" in red.
<b>DESCRIPTION:</b>	<b>UDFN6 1.0X1.0, 0.35P</b>	<b>PAGE 1 OF 1</b>

onsemi and ONSEMI are trademarks of Semiconductor Components Industries, LLC dba onsemi or its subsidiaries in the United States and/or other countries. onsemi reserves the right to make changes without further notice to any products herein. onsemi makes no warranty, representation or guarantee regarding the suitability of its products for any particular purpose, nor does onsemi assume any liability arising out of the application or use of any product or circuit, and specifically disclaims any and all liability, including without limitation special, consequential or incidental damages. onsemi does not convey any license under its patent rights nor the rights of others.

**onsemi**, **Onsemi**, and other names, marks, and brands are registered and/or common law trademarks of Semiconductor Components Industries, LLC dba "**onsemi**" or its affiliates and/or subsidiaries in the United States and/or other countries. **onsemi** owns the rights to a number of patents, trademarks, copyrights, trade secrets, and other intellectual property. A listing of **onsemi**'s product/patent coverage may be accessed at [www.onsemi.com/site/pdf/Patent-Marking.pdf](http://www.onsemi.com/site/pdf/Patent-Marking.pdf). **onsemi** reserves the right to make changes at any time to any products or information herein, without notice. The information herein is provided "as-is" and **onsemi** makes no warranty, representation or guarantee regarding the accuracy of the information, product features, availability, functionality, or suitability of its products for any particular purpose, nor does **onsemi** assume any liability arising out of the application or use of any product or circuit, and specifically disclaims any and all liability, including without limitation special, consequential or incidental damages. Buyer is responsible for its products and applications using **onsemi** products, including compliance with all laws, regulations and safety requirements or standards, regardless of any support or applications information provided by **onsemi**. "Typical" parameters which may be provided in **onsemi** data sheets and/or specifications can and do vary in different applications and actual performance may vary over time. All operating parameters, including "Typicals" must be validated for each customer application by customer's technical experts. **onsemi** does not convey any license under any of its intellectual property rights nor the rights of others. **onsemi** products are not designed, intended, or authorized for use as a critical component in life support systems or any FDA Class 3 medical devices or medical devices with a same or similar classification in a foreign jurisdiction or any devices intended for implantation in the human body. Should Buyer purchase or use **onsemi** products for any such unintended or unauthorized application, Buyer shall indemnify and hold **onsemi** and its officers, employees, subsidiaries, affiliates, and distributors harmless against all claims, costs, damages, and expenses, and reasonable attorney fees arising out of, directly or indirectly, any claim of personal injury or death associated with such unintended or unauthorized use, even if such claim alleges that **onsemi** was negligent regarding the design or manufacture of the part. **onsemi** is an Equal Opportunity/Affirmative Action Employer. This literature is subject to all applicable copyright laws and is not for resale in any manner.

## ADDITIONAL INFORMATION

### TECHNICAL PUBLICATIONS:

Technical Library: [www.onsemi.com/design/resources/technical-documentation](http://www.onsemi.com/design/resources/technical-documentation)  
onsemi Website: [www.onsemi.com](http://www.onsemi.com)

### ONLINE SUPPORT: [www.onsemi.com/support](http://www.onsemi.com/support)

For additional information, please contact your local Sales Representative at [www.onsemi.com/support/sales](http://www.onsemi.com/support/sales)

## Looking for pricing, stock, or lifecycle information?

Click below to explore more details on WIN SOURCE:

- ⊖ [View FXLP34FHX](#) on WIN SOURCE
- ⊖ [ON Semiconductor](#) Information

## Optimize Your Supply Chain with WIN SOURCE Solutions

- ✓ Global Sourcing Solution
- ✓ Obsolete Management
- ✓ Cost Control Management
- ✓ Shortage Management
- ✓ Alternative Solution
- ✓ Excess Inventory Management