



**THE DATASHEET OF
IDT5V5218PGGI**





Dual Channel Type-1/Type-2 M-LVDS to LVTTL/LVPECL/LVDS Transceiver IDT5V5218

**Version -
May 18, 2006**

6024 Silver Creek Valley Road, San Jose, CA 95138
Telephone: (800) 345-7015 • TWX: 910-338-2070 • FAX: (408) 284-2775
Printed in U.S.A.
© 2006 Integrated Device Technology, Inc.

DISCLAIMER

Integrated Device Technology, Inc. reserves the right to make changes to its products or specifications at any time, without notice, in order to improve design or performance and to supply the best possible product. IDT does not assume any responsibility for use of any circuitry described other than the circuitry embodied in an IDT product. The Company makes no representations that circuitry described herein is free from patent infringement or other rights of third parties which may result from its use. No license is granted by implication or otherwise under any patent, patent rights or other rights, of Integrated Device Technology, Inc.

LIFE SUPPORT POLICY

Integrated Device Technology's products are not authorized for use as critical components in life support devices or systems unless a specific written agreement pertaining to such intended use is executed between the manufacturer and an officer of IDT.

1. Life support devices or systems are devices or systems which (a) are intended for surgical implant into the body or (b) support or sustain life and whose failure to perform, when properly used in accordance with instructions for use provided in the labeling, can be reasonably expected to result in a significant injury to the user.
 2. A critical component is any components of a life support device or system whose failure to perform can be reasonably expected to cause the failure of the life support device or system, or to affect its safety or effectiveness.
-



Table of Contents

TABLE OF CONTENTS	3
LIST OF TABLES	4
LIST OF FIGURES	5
FEATURES.....	6
APPLICATIONS.....	6
DESCRIPTION.....	6
FUNCTIONAL BLOCK DIAGRAM	7
1 PIN ASSIGNMENT	8
2 PIN DESCRIPTION	9
3 ELECTRICAL SPECIFICATION	11
3.1 ABSOLUTE MAXIMUM RATING AND RECOMMENDED OPERATION CONDITIONS	11
3.2 LVTTTL/LVDS/LVPECL DRIVER/RECEIVER CHARACTERISTICS	12
3.2.1 M-LVDS to LVTTTL.....	12
3.2.2 M-LVDS to LVDS.....	13
3.2.3 M-LVDS to LVPECL.....	16
3.3 M-LVDS DRIVER TYPE-1/TYPE-2 RECEIVER CHARACTERISTICS	17
ORDERING INFORMATION.....	24



List of Tables

Table-1	Pin Description	9
Table-2	Absolute Maximum Rating	11
Table-3	Recommended Operation Conditions	11
Table-4	LVTTL DC Parameters	12
Table-5	LVTTL AC Parameters	12
Table-6	LVDS DC Parameters	13
Table-7	LVDS AC Parameters	15
Table-8	Differential LVPECL DC Parameters	16
Table-9	Differential LVPECL AC Parameters	16
Table-10	M-LVDS Type-1 Receiver Input Threshold Test Voltages	17
Table-11	M-LVDS Type-2 Receiver Input Threshold Test Voltages	17
Table-12	M-LVDS DC Parameters	18
Table-13	M-LVDS Input Current Parameters	20
Table-14	M-LVDS AC Parameters	21
Table-15	M-LVDS Type-1/Type-2 Receiver AC Parameters	22
Table-16	M-LVDS Receiver output DC Parameters	23
Table-17	M-LVDS Driver AC Parameter	23



List of Figures

Figure-1	Functional Block Diagram	7
Figure-2	IDT5V5218 TSSOP24 Package Pin Assignment	8
Figure-3	LVTTTL Output Test Circuit and Waveforms	12
Figure-4	LVDS Receiver Input Common-mode Range Test Circuit	13
Figure-5	LVDS Driver Output Voltage Test Circuit	14
Figure-6	LVDS Driver Shorted to Ground	14
Figure-7	LVDS Driver Shorted Together	14
Figure-8	LVDS Output Test Circuit	15
Figure-9	LVPECL Driver Output Test Circuit and Waveforms	16
Figure-10	M-LVDS Driver Output Voltage Test Circuit	18
Figure-11	M-LVDS Driver Short-Circuit Test Circuit	18
Figure-12	M-LVDS Type-1/Type-2 Receiver Input Common-mode Range Test Circuit	19
Figure-13	Various Input Currents Test Circuit	20
Figure-14	Differential Skew	21
Figure-15	M-LVDS Output Voltage Test Circuit	21
Figure-16	Timing and Voltage Definitions for the Output Signal	23



FEATURES

◆ Main Features

- Two independent channels
- Type-2 M-LVDS receiver supports 100 mV offset threshold
- Up to 166 MHz selectable input/output signals: LVTTTL/LVPECL/LVDS
- M-LVDS interface allows common-mode voltage: -1 V to 3.4 V
- Power up and power down glitch free
- M-LVDS interface pins in high impedance state when the device is powered down or $V_{DD} < 1.5$ V
- Capable of driving bus load from 30 Ω to 55 Ω

◆ Other Features

- Low power consumption < 220 mW
- Hot swappable
- 24-pin TSSOP package

APPLICATIONS

- Backplane transmission
- Telecommunication system
- Data communications
- ATCA clock distribution

DESCRIPTION

The IDT5V5218 is a dual-channel transceiver which can interchange data across multipoint data bus structures.

In the device, the two channels operate independently. Each channel has selectable LVTTTL/LVPECL/LVDS drivers and receivers, a selectable Type-1/Type-2 M-LVDS receiver and M-LVDS driver. It translates

between LVTTTL/LVPECL/LVDS signals and M-LVDS signals. The drivers and the receivers can be enabled or disabled by external pins. The M-LVDS driver is capable of driving bus load from 30 Ω to 55 Ω . The M-LVDS interface allows common-mode voltage range of -1 V to 3.4 V.

FUNCTIONAL BLOCK DIAGRAM

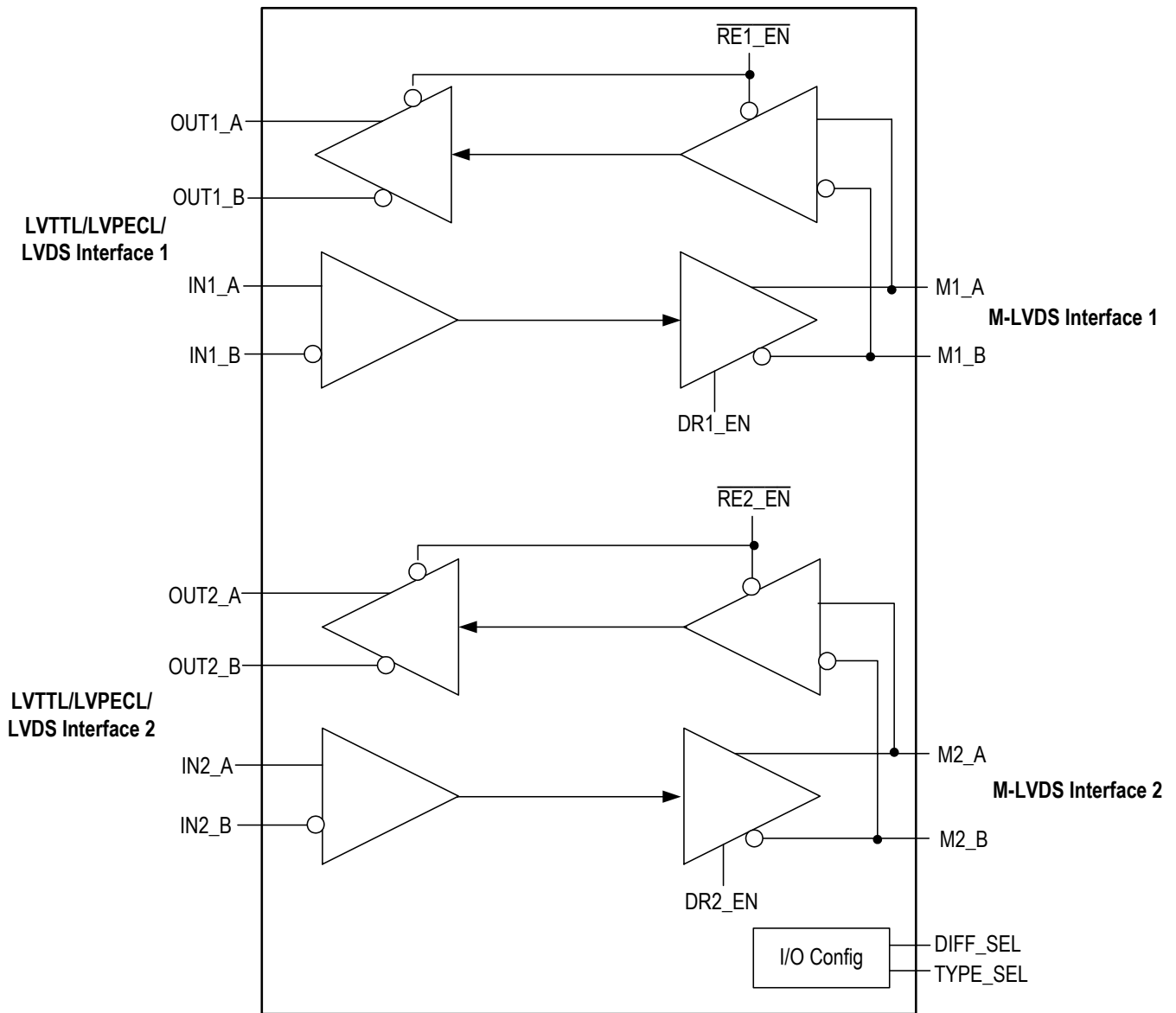

Figure-1 Functional Block Diagram

1 PIN ASSIGNMENT

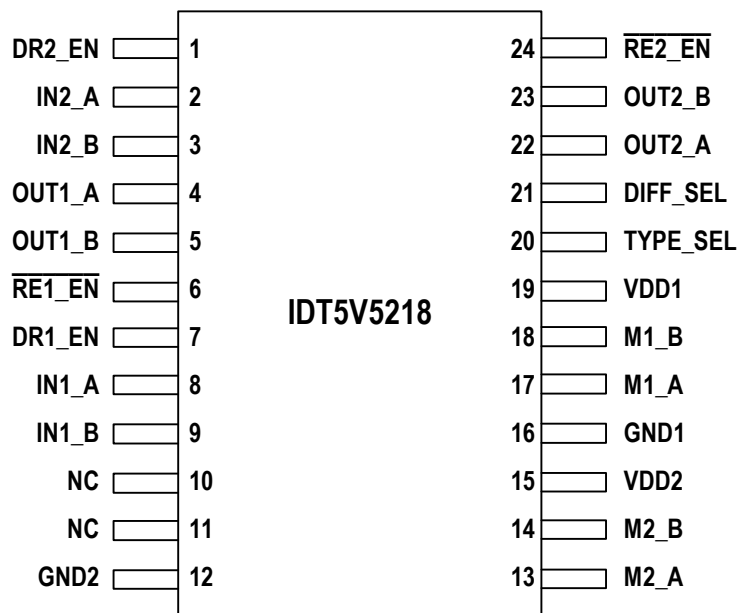

Figure-2 IDT5V5218 TSSOP24 Package Pin Assignment

2 PIN DESCRIPTION

Table-1 Pin Description

Name	Pin No.	I/O	Type	Description
Global Signal				
DR1_EN	7	I Pull-down	LVTTTL	DR1_EN: M-LVDS Driver 1 Enable This pin controls the M-LVDS driver for channel 1: high for enable and low for disable.
$\overline{\text{RE1_EN}}$	6	I Pull-up	LVTTTL	RE1_EN: Type-1/Type-2 M-LVDS Receiver 1 and LVTTTL/LVPECL/LVDS Drivers 1 Enable This pin controls the Type-1/Type-2 M-LVDS receiver and LVTTTL/LVPECL/LVDS drivers for channel 1: high for disable and low for enable. Note that the LVTTTL driver is in high impedance state when disabled.
DR2_EN	1	I Pull-down	LVTTTL	DR2_EN: M-LVDS Driver 2 Enable This pin controls the M-LVDS driver for channel 2: high for enable and low for disable.
$\overline{\text{RE2_EN}}$	24	I Pull-up	LVTTTL	RE2_EN: Type-1/Type-2 M-LVDS Receiver 2 and LVTTTL/LVPECL/LVDS Drivers 2 Enable This pin controls the Type-1/Type-2 M-LVDS receiver and LVTTTL/LVPECL/LVDS drivers for channel 2: high for disable and low for enable. Note that the LVTTTL driver is in high impedance state when disabled.
TYPE_SEL	20	I Pull-down	LVTTTL	TYPE_SEL: Type-1/Type-2 M-LVDS Receiver Selection This pin globally controls the Type-1/Type-2 M-LVDS receiver selection: high for Type-2 and low for Type-1.
DIFF_SEL	21	I Pull to VDD/2	LVTTTL	DIFF_SEL: Type Selection for LVTTTL/LVPECL/LVDS Interface Input/Output 1 and 2 This pin globally determines the type of input/output 1 and 2 of the LVTTTL/LVPECL/LVDS interface: high for LVDS, floating for LVTTTL and low for LVPECL.
LVTTTL/LVPECL/LVDS Interface				
IN1_A IN1_B	8 9	I	LVTTTL/LVPECL/LVDS LVPECL/LVDS	IN1_A/IN1_B: Positive/Negative LVPECL/LVDS Input 1 An up to 166 MHz differential signal is input on this pair of pins. The input signal can be LVPECL or LVDS, as selected by the DIFF_SEL pin. IN1_A: LVTTTL Input 1 An up to 166 MHz LVTTTL signal is input on this pin, as selected by the DIFF_SEL pin. In this case, the IN1_B pin will be in high impedance state.
IN2_A IN2_B	2 3	I	LVTTTL/LVPECL/LVDS LVPECL/LVDS	IN2_A/IN2_B: Positive/Negative LVPECL/LVDS Input 2 An up to 166 MHz differential signal is input on this pair of pins. The input signal can be LVPECL or LVDS, as selected by the DIFF_SEL pin. IN2_A: LVTTTL Input 2 An up to 166 MHz LVTTTL signal is input on this pin, as selected by the DIFF_SEL pin. In this case, the IN2_B pin will be in high impedance state.
OUT1_A OUT1_B	4 5	O	LVTTTL/LVPECL/LVDS LVPECL/LVDS	OUT1_A/OUT1_B: Positive/Negative LVPECL/LVDS Output 1 This pair of pins output an up to 166 MHz differential signal. The output signal can be LVPECL or LVDS, as selected by the DIFF_SEL pin. OUT1_A: LVTTTL Output 1 This pin outputs an up to 166 MHz LVTTTL signal, as selected by the DIFF_SEL pin. In this case, the OUT1_B pin will be in high impedance state.

Table-1 Pin Description (Continued)

Name	Pin No.	I/O	Type	Description
OUT2_A OUT2_B	22 23	O	LVTTTL/LVPECL/LVDS LVPECL/LVDS	<p>OUT2_A/OUT2_B: Positive/Negative LVPECL/LVDS Output 2 This pair of pins output an up to 166 MHz differential signal. The output signal can be LVPECL or LVDS, as selected by the DIFF_SEL pin.</p> <p>OUT2_A: LVTTTL Output 2 This pin outputs an up to 166 MHz LVTTTL signal, as selected by the DIFF_SEL pin. In this case, the OUT2_B pin will be in high impedance state.</p>
M-LVDS Interface				
M1_A M1_B	17 18	I/O	M-LVDS	M1_A/M1_B: Positive/Negative M-LVDS Data Bus Interface 1 This pair of pins are connected to the M-LVDS data bus.
M2_A M2_B	13 14	I/O	M-LVDS	M2_A/M2_B: Positive/Negative M-LVDS Data Bus Interface 2 This pair of pins are connected to the M-LVDS data bus.
Power Supply and Ground				
VDD1	19	Power	-	3.3 V Power Supply for Channel 1
VDD2	15	Power	-	3.3 V Power Supply for Channel 2
GND1	16	Ground	-	Ground for Channel 1
GND2	12	Ground	-	Ground for Channel 2
Others				
NC	10, 11	-	-	NC: No Connection

3 ELECTRICAL SPECIFICATION

3.1 ABSOLUTE MAXIMUM RATING AND RECOMMENDED OPERATION CONDITIONS

Table-2 Absolute Maximum Rating

Symbol	Parameter		Range
V_{DD}	Supply Voltage		-0.5 V to 4.1 V
V_{IN}	Input Voltage	$\overline{REN_EN}^{(1)}$, DRn_EN, INn_A, INn_B	-0.5 V to 4.1 V
		Mn_A, Mn_B	-1.8 V to 4 V
V_{OUT}	Output Voltage	OUTn_A, OUTn_B	-0.3 V to 4 V
		Mn_A, Mn_B	-1.8 V to 4 V
	Electrostatic Discharge	Human Body Model Mn_A, Mn_B	± 8 kV
		All pins	± 2 kV
T_J	Junction Temperature	150°C	
T_S	Storage Temperature	-65°C to 165°C	

¹ n = 1, 2

Table-3 Recommended Operation Conditions

Symbol	Parameter	Min	Typ	Max	Unit
V_{DD}	Power Supply	3.0	3.3	3.6	V
V_{IH}	High Level Input Voltage	2		3.0	V
V_{IL}	Low Level Input Voltage	0		0.8	V
	Voltage at any Bus Terminal	-1.4		3.8	V
	Magnitude of Differential Input Voltage	0.05		3.0	V
T_A	Ambient Operating Temperature	-40		85	°C

3.2 LVTTTL/LVDS/LVPECL DRIVER/RECEIVER CHARACTERISTICS

3.2.1 M-LVDS TO LVTTTL

Table-4 LVTTTL DC Parameters

Symbol	Parameter	Test Conditions	Min	Typ	Max	Unit
V_{IHL}	Input High Level		2.0		$V_{DD} + 0.3$	V
V_{ILL}	Input Low Level		-0.3		0.8	V
I_{ILL}	Input Leakage Current		-1.0		1.0	μ A
V_{OHL}	Output High Voltage	Output Current = 17 mA, $V_{DD} = 3$ V	2.4			V
V_{OLL}	Output Low Voltage	Output Current = 12 mA, $V_{DD} = 3$ V			0.4	V

Table-5 LVTTTL AC Parameters

Symbol	Parameter	Test Conditions	Min	Typ	Max	Unit
t_r	Rise Time	$C_{load} = 15$ pF, 10% - 90%			1.2	ns
t_f	Fall Time	$C_{load} = 15$ pF, 10% - 90%			1.2	ns
f_{ML}	Frequency				166	MHz

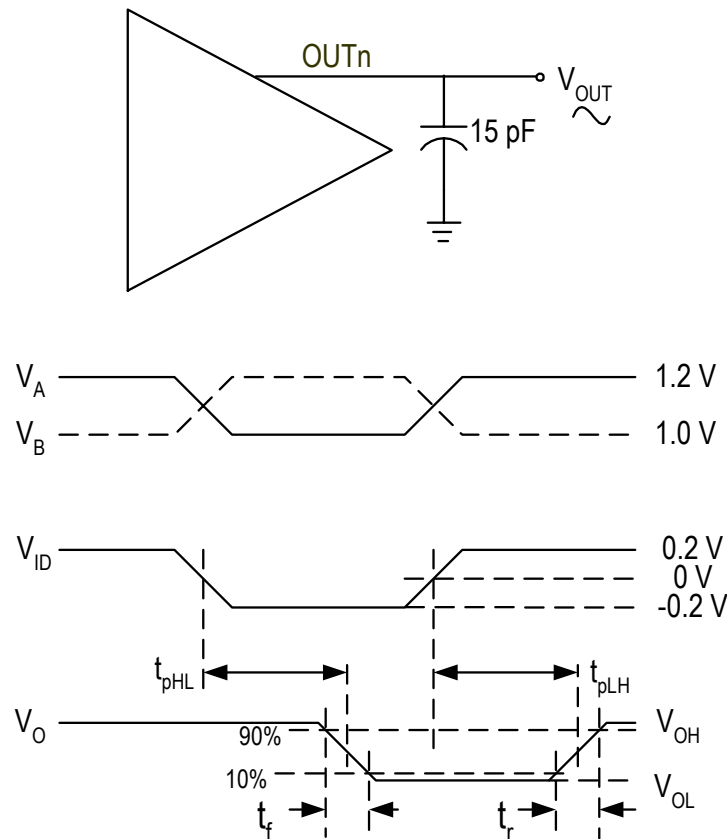

Figure-3 LVTTTL Output Test Circuit and Waveforms

3.2.2 M-LVDS TO LVDS

Table-6 LVDS DC Parameters

Symbol	Parameter	Test Conditions	Min	Typ	Max	Unit
V_{CM}	Input Common-mode Voltage Range		0	1200	2400	mV
V_{DIFF}	Input Peak Differential Voltage		100		900	mV
V_{IDTH}	Input Differential Threshold		-100		100	mV
I_{IN}	Input Leakage Current				20	μ A
V_{OH}	Output Voltage High	$R_{load} = 100 \Omega \pm 1\%$	1350		1475	mV
V_{OL}	Output Voltage Low	$R_{load} = 100 \Omega \pm 1\%$	925		1100	mV
V_{OD}	Differential Output Voltage	$R_{load} = 100 \Omega \pm 1\%$	250		450	mV
V_{OS}	Output Offset Voltage	$R_{load} = 100 \Omega \pm 1\%$	1100		1300	mV
R_0	Differential Output Impedance	$V_{CM} = 1.0 \text{ V or } 1.4 \text{ V}$	80	100	120	Ohm
ΔV_{OD}	Change in V_{OD} between Logic 0 and Logic 1	$R_{load} = 100 \Omega \pm 1\%$			25	mV
ΔV_{OS}	Change in V_{OS} between Logic 0 and Logic 1	$R_{load} = 100 \Omega \pm 1\%$			25	mV
$I_{SA}I_{SB}$	Output Current	Driver shorted to GND			24	mA
I_{SAB}	Output Current	Driver shorted together			12	mA

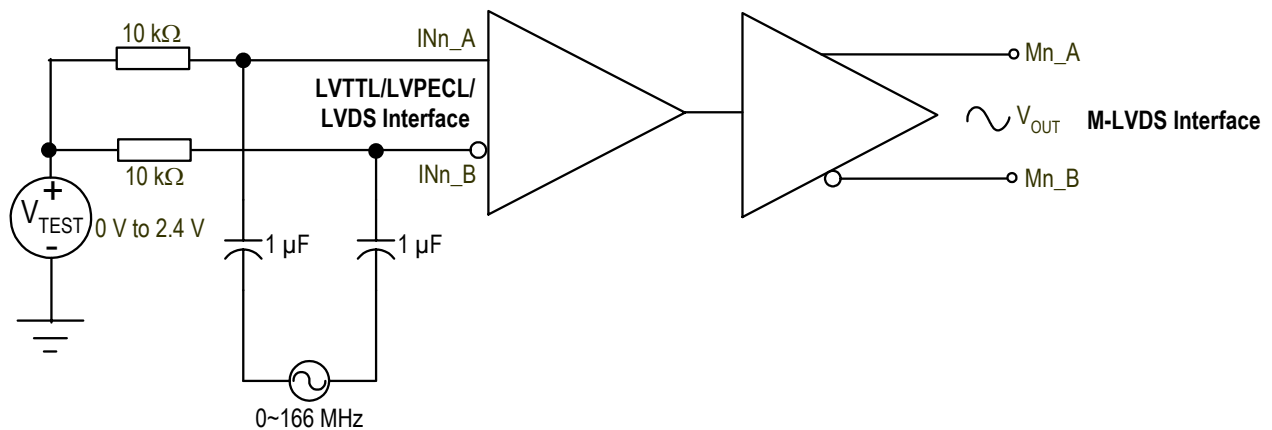

Figure-4 LVDS Receiver Input Common-mode Range Test Circuit

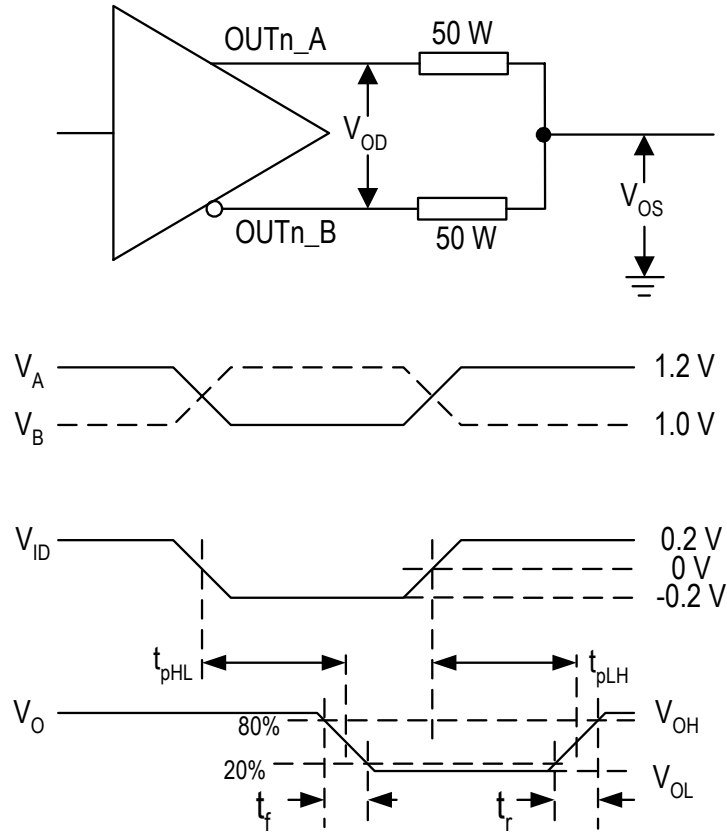

Figure-5 LVDS Driver Output Voltage Test Circuit

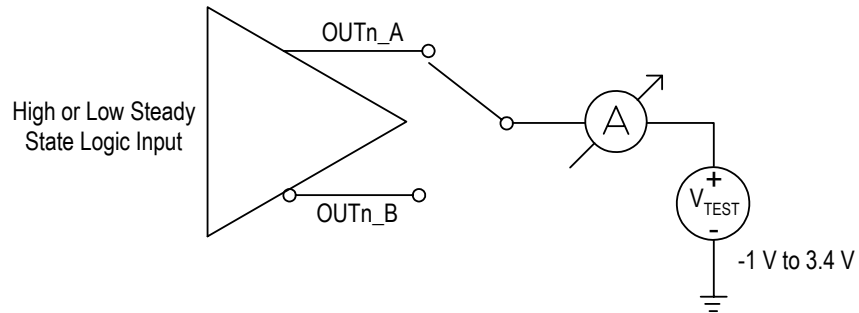

Figure-6 LVDS Driver Shorted to Ground

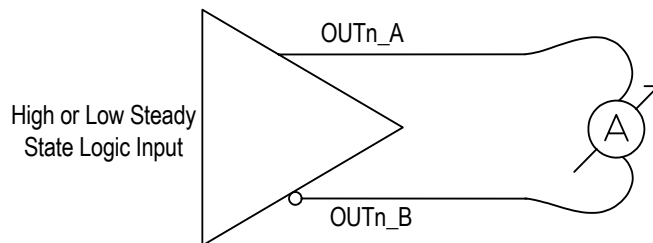

Figure-7 LVDS Driver Shorted Together

Table-7 LVDS AC Parameters

Symbol	Parameter	Test Conditions	Min	Typ	Max	Unit
t_r	Rise Time	20% - 80%	150		350	ps
t_f	Fall Time	20% - 80%	150		350	ps
t_{TSP}	Differential Skew		-50		50	ps
f_{MM}	Frequency				166	MHz

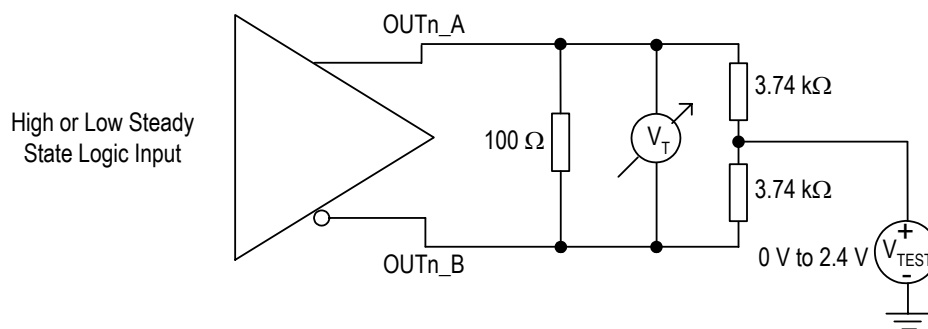

Figure-8 LVDS Output Test Circuit

3.2.3 M-LVDS TO LVPECL

Table-8 Differential LVPECL DC Parameters

Symbol	Parameter	Min	Typ	Max	Unit
V_{IL}	Input Low Voltage, Differential Inputs	$V_{DD}-2.5$		$V_{DD}-0.5$	V
V_{IH}	Input High Voltage, Differential Inputs	$V_{DD}-2.4$		$V_{DD}-0.4$	V
V_{ID}	Input Differential Voltage	0.1		1.4	V
I_{IH}	Input High Current, $V_{ID} = 1.4$ V	-10		10	μ A
I_{IL}	Input Low Current, $V_{ID} = 1.4$ V	-10		10	μ A
V_{OL}	Output Voltage Low	$V_{DD}-2.1$		$V_{DD}-1.6$	V
V_{OH}	Output Voltage High	$V_{DD}-1.25$		$V_{DD}-0.88$	V
V_{OS}	Output Differential Voltage	580		950	mV

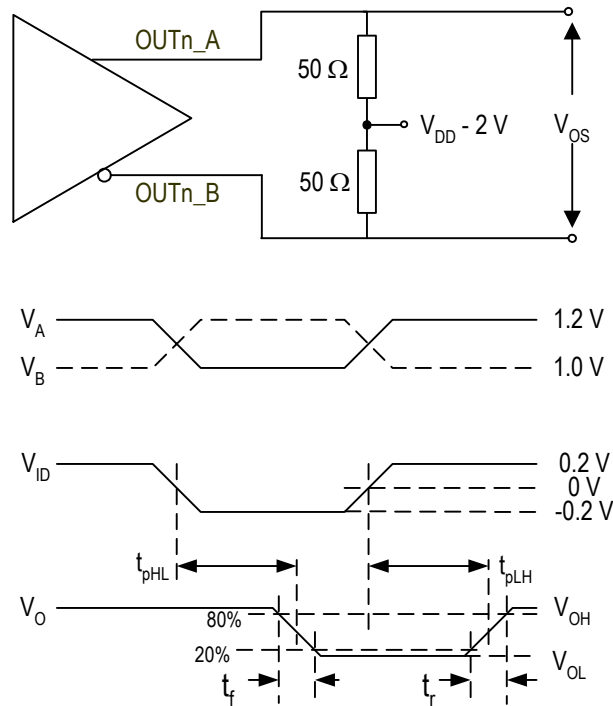

Figure-9 LVPECL Driver Output Test Circuit and Waveforms

Table-9 Differential LVPECL AC Parameters

Symbol	Parameter	Test Conditions	Min	Typ	Max	Unit
t_r	Rise Time	20% - 80%	150		350	ps
t_f	Fall Time	20% - 80%	150		350	ps
t_{TSP}	Differential Skew		-50		50	ps
f_{MM}	Frequency				166	MHz

3.3 M-LVDS DRIVER TYPE-1/TYPE-2 RECEIVER CHARACTERISTICS

Table-10 M-LVDS Type-1 Receiver Input Threshold Test Voltages

Applied Voltages		Resulting Differential Input Voltage	Resulting Common-mode Input Voltage	Receiver Output ⁽¹⁾
V _A	V _B			
2.400	0.000	2.400	1.200	High
0.000	2.400	-2.400	1.200	Low
3.425	3.375	0.050	3.4	High
3.375	3.425	-0.050	3.4	Low
-0.975	-1.025	0.050	-1	High
-1.025	-0.975	-0.050	-1	Low

¹The receiver is enabled (The RE1_EN or RE2_EN pin is pulled low).

Table-11 M-LVDS Type-2 Receiver Input Threshold Test Voltages

Applied Voltages		Resulting Differential Input Voltage	Resulting Common-mode Input Voltage	Receiver Output ⁽¹⁾
V _A	V _B			
2.400	0.000	2.400	1.200	High
0.000	2.400	-2.400	1.200	Low
3.475	3.325	0.150	3.4	High
3.425	3.375	0.050	3.4	Low
-0.925	-1.075	0.150	-1	High
-0.975	-1.025	0.050	-1	Low

¹The receiver is enabled (The RE1_EN or RE2_EN pin is pulled low).

Table-12 M-LVDS DC Parameters

Symbol	Parameter	Test Conditions	Min	Typ	Max	Unit
V_{ODM}	Differential Output Voltage		480		650	mV
ΔV_{ODM}	Change in V_{ODM} for Complimentary Output States, $\Delta V_{ODM} = V_{ODM1} - V_{ODM0} $		-50		50	mV
V_{OSM}	Offset Voltage		0.8		1.2	V
ΔV_{OSM}	Change in V_{OSM} for Complimentary Output States		-50		50	mV
$V_{OSM(p-p)}$	Peak-to-peak Common-mode Output Voltage				150	mV
I_{OM}	Output Short Circuit Current				20	mA
I_{IZM}	High Impedance Input Current		-10		10	μ A
V_{THM}	Differential Input High Threshold	Type-1 Type-2	50 150			mV
V_{TLM}	Differential Input Low Threshold	Type-1 Type-2			-50 +50	mV
V_{CMM}	Input Common-mode Range	$V_{INA} - V_{INB} = 200$ mV	-1		3.4	V
I_{INM}	Input Current	Input Voltage = 0 V to 2.4 V	-20		20	μ A

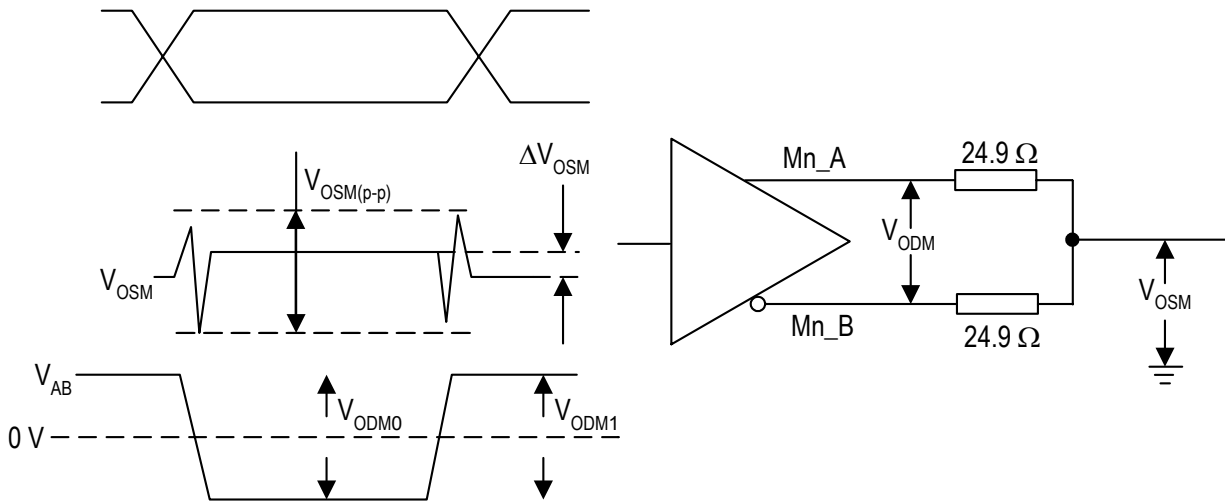

Figure-10 M-LVDS Driver Output Voltage Test Circuit

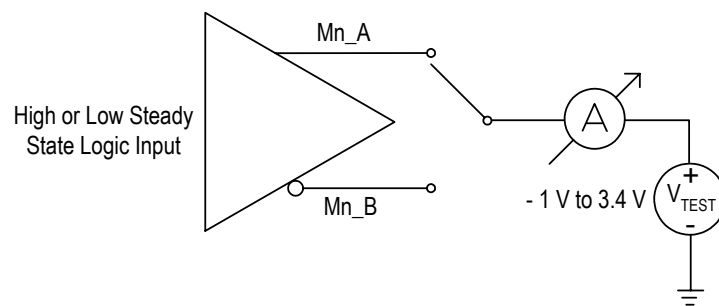

Figure-11 M-LVDS Driver Short-Circuit Test Circuit

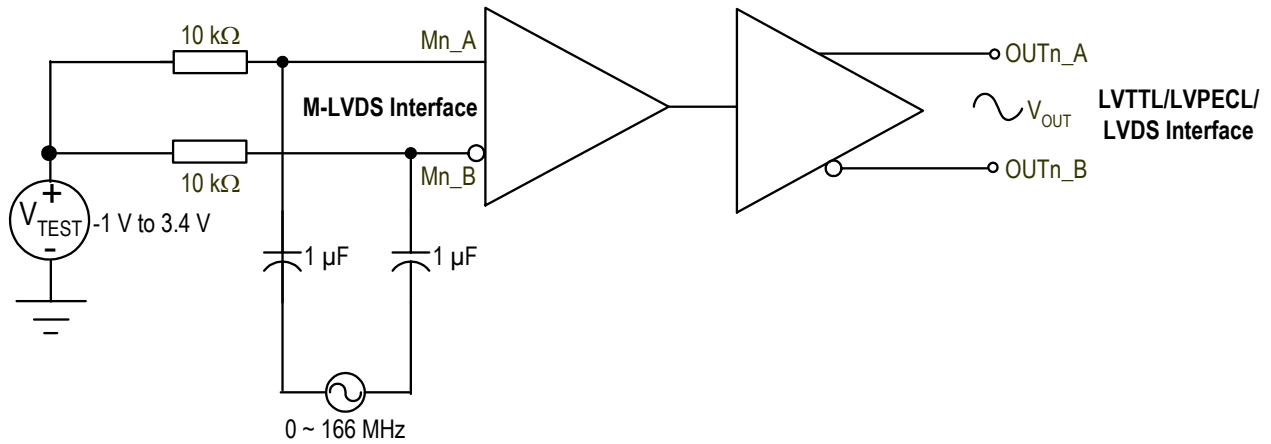

Figure-12 M-LVDS Type-1/Type-2 Receiver Input Common-mode Range Test Circuit

Table-13 M-LVDS Input Current Parameters

Symbol	Parameter	Test Conditions	Min	Typ	Max	Unit
I_A	Receiver or Transceiver with Driver Disabled Input Current	$V_A = 3.8 \text{ V}, V_B = 1.2 \text{ V}$	0		32	μA
		$V_A = 0 \text{ V or } 2.4 \text{ V}, V_B = 1.2 \text{ V}$	-20		20	
		$V_A = -1.4 \text{ V}, V_B = 1.2 \text{ V}$	-32		0	
I_B	Receiver or Transceiver with Driver Disabled Input Current	$V_B = 3.8 \text{ V}, V_A = 1.2 \text{ V}$	0		32	μA
		$V_B = 0 \text{ V or } 2.4 \text{ V}, V_A = 1.2 \text{ V}$	-20		20	
		$V_B = -1.4 \text{ V}, V_A = 1.2 \text{ V}$	-32		0	
I_{AB}	Receiver or Transceiver with Driver Differential Current ($I_A - I_B$)	$V_A = V_B, -1.4 \text{ V} < V_A < 3.8 \text{ V}$	-4		4	μA
$I_{A(\text{OFF})}$	Receiver or Transceiver Power-off Input Current	$V_A = 3.8 \text{ V}, V_B = 1.2 \text{ V}, 0 \text{ V} < V_{DD} < 1.5 \text{ V}$	0		32	μA
		$V_A = 0 \text{ or } 2.4 \text{ V}, V_B = 1.2 \text{ V}, 0 \text{ V} < V_{DD} < 1.5 \text{ V}$	-20		20	
		$V_A = -1.4 \text{ V}, V_B = 1.2 \text{ V}, 0 \text{ V} < V_{DD} < 1.5 \text{ V}$	-32		0	
$I_{B(\text{OFF})}$	Receiver or Transceiver Power-off Input Current	$V_B = 3.8 \text{ V}, V_A = 1.2 \text{ V}, 0 \text{ V} < V_{DD} < 1.5 \text{ V}$	0		32	μA
		$V_B = 0 \text{ or } 2.4 \text{ V}, V_A = 1.2 \text{ V}, 0 \text{ V} < V_{DD} < 1.5 \text{ V}$	-20		20	
		$V_B = -1.4 \text{ V}, V_A = 1.2 \text{ V}, 0 \text{ V} < V_{DD} < 1.5 \text{ V}$	-32		0	
$I_{AB(\text{OFF})}$	Receiver or Transceiver Power-off Differential Input Current ($I_A - I_B$)	$V_A = V_B, 0 \text{ V} < V_{DD} < 1.5 \text{ V}, -1.4 \text{ V} < V_A < 3.8 \text{ V}$	-4		4	μA
C_{AB}	Transceiver with driver disabled differential input capacitance	$V_{AB} = 0.4 \sin(30E6\pi t) \text{ V}$			4	pF

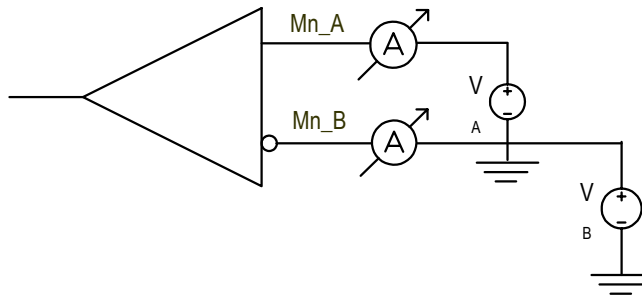

Figure-13 Various Input Currents Test Circuit

Table-14 M-LVDS AC Parameters

Symbol	Parameter	Test Conditions	Min.	Typ	Max.	Unit
t_r	Rise Time	10% - 90%	0.8		1.5	ns
t_f	Fall Time	10% - 90%	0.8		1.5	ns
t_{TSL}	Differential Skew, $t_{TSL} = \{t_{TSL1}, t_{TSL2}\}$		-100		100	ps
f_{ML}	Frequency				166	MHz

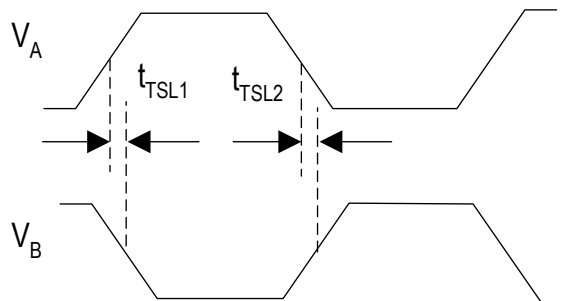

Figure-14 Differential Skew

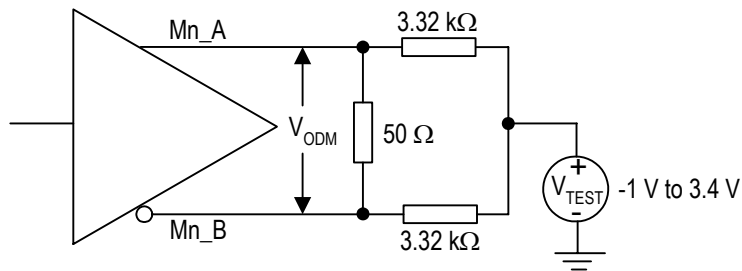

Figure-15 M-LVDS Output Voltage Test Circuit

Table-15 M-LVDS Type-1/Type-2 Receiver AC Parameters

Output mode	Symbol	Parameter	Test Condition	Min	Typ	Max	Unit	
LVTTTL	t_{pLH}	Delay, Low to High Level	Input clock: freq = 50 MHz, Impedance = 150 Ω , Voltage = -200 mV - 200 mV. See Figure-3	2.5	5.5	6.5	ns	
	t_{pHL}	Delay, High to Low Level		2.5	5.5	6.5	ns	
	t_{sk}	Type-1		Pulse Skew, $t_{sk} = t_{pLH} - t_{pHL} $		100	300	ps
		Type-2				300	500	ps
	T_r (10% - 90%)	Rise Time			1		2.4	ns
	T_f (10% - 90%)	Fall Time			1		2.4	ns
	$T_{jit(per)}$	Period jitter, rms(1 standard deviation)				4	7	ps
		Output to Output Skew					200	ps
LVDS	t_{pLH}	Delay, Low to High Level	Input clock: freq = 50 MHz, Impedance = 150 Ω , Voltage = -200 mV - 200 mV. See Figure-5	2.5	4.0	5.5	ns	
	t_{pHL}	Delay, High to Low Level		2.5	4.0	5.5	ns	
	t_{sk}	Type-1		Pulse Skew, $t_{sk} = t_{pLH} - t_{pHL} $		150	300	ps
		Type-2				250	500	ps
	T_r (20% - 80%)	Rise Time			150	200	350	ps
	T_f (20% - 80%)	Fall Time			150	200	350	ps
	$T_{jit(per)}$	Period jitter, rms(1 standard deviation)				4	7	ps
		Output to Output Skew					200	ps
LVPECL	t_{pLH}	Delay, Low to High Level	Input clock: freq = 50 MHz, Impedance = 150 Ω , Voltage = -200 mV - 200 mV. See Figure-9	2.5	4	5.5	ns	
	t_{pHL}	Delay, High to Low Level		2.5	4	5.5	ns	
	t_{sk}	Type-1		Pulse Skew, $t_{sk} = t_{pLH} - t_{pHL} $		150	300	ps
		Type-2				200	500	ps
	T_r (20% - 80%)	Rise Time			150	250	350	ps
	T_f (20% - 80%)	Fall Time			150	250	350	ps
	$T_{jit(per)}$	Period jitter, rms(1 standard deviation)				4	7	ps
		Output to Output Skew					200	ps

Table-16 M-LVDS Receiver output DC Parameters

Output mode	Symbol	Parameter	Test Condition	Min	Typ	Max	Unit
LVPECL	V_{OD}	Differential Output Voltage		580		950	mV
LVDS	V_{OS}	Output Offset Voltage		1100	1200	1300	mV
	V_{OD}	Differential Output Voltage		250	350	450	mV
	I_{SA}, I_{SB}	Output Current				28	mA
	V_{ODM}	Differential Output Voltage		480		650	mV

Table-17 M-LVDS Driver AC Parameter

Symbol	Parameter	Test Condition	Min	Typ	Max	Unit	
t_{pLH}	Delay, Low to High Level	Input clock: freq = 15 MHz, $T_r = T_f = 1.2$ ns, Impedance = 300 Ω , Voltage = 0 V - 3.3 V. See Figure-10	2.5	3.7	5.5	ns	
t_{pHL}	Delay, High to Low Level		2.5	3.7	5.5	ns	
Tsk	LVTTTL input		Pulse Skew, $t_{sk} = t_{pLH} - t_{pHL} $		40	100	ps
	LVDS/LVPECL input				250	400	ps
T_r (10% - 90%)	Rise Time		0.7	1.1	1.5	ns	
T_f (10% - 90%)	Fall Time		0.7	1.1	1.5	ns	
$T_{jit(per)}$	Period jitter, rms (1 standard deviation)			2	3	ps	
	Output to Output Skew				100	ps	

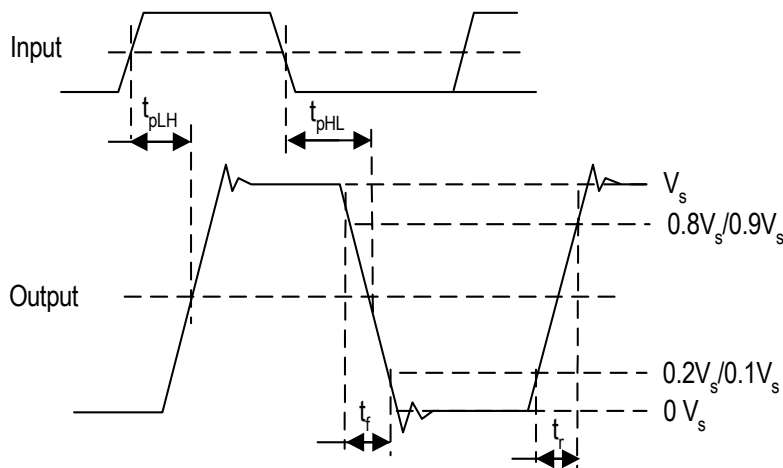
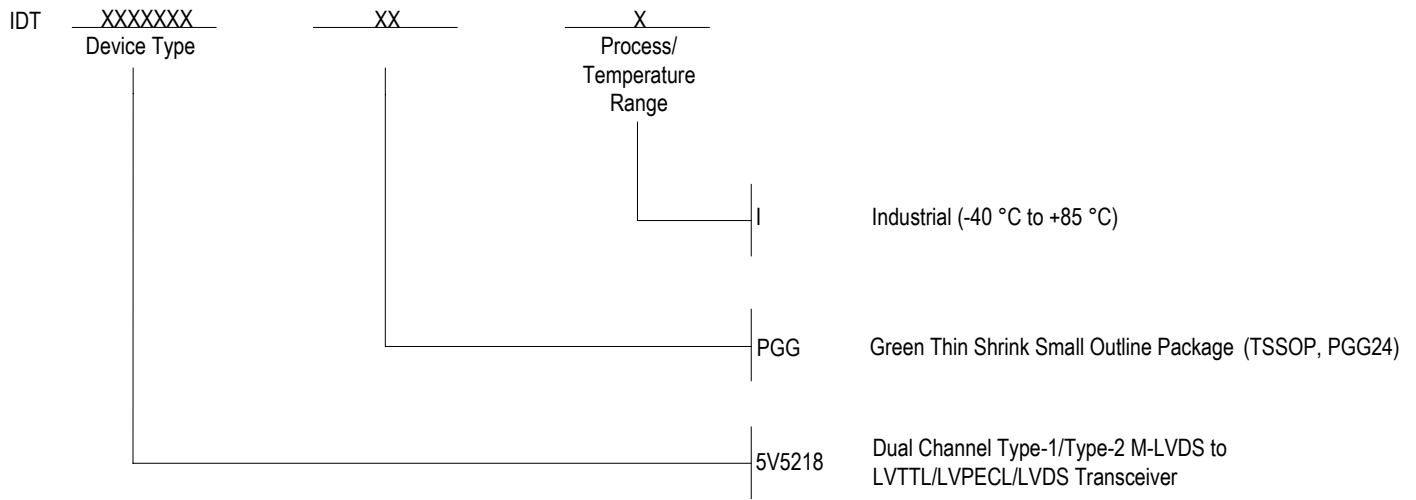

Figure-16 Timing and Voltage Definitions for the Output Signal

ORDERING INFORMATION



CORPORATE HEADQUARTERS
 6024 Silver Creek Valley Road
 San Jose, CA 95138

for SALES:
 1-800-345-7015 or 408-284-8200
 fax: 408-284-2775
www.idt.com

for Tech Support:
 408-360-1552
 email: TELECOMhelp@idt.com

Looking for pricing, stock, or lifecycle information?

Click below to explore more details on WIN SOURCE:

-  [View IDT5V5218PGGI on WIN SOURCE](#)
-  [IDT, Integrated Device Technology Inc Information](#)

Optimize Your Supply Chain with WIN SOURCE Solutions

-  Global Sourcing Solution
-  Obsolete Management
-  Cost Control Management
-  Shortage Management
-  Alternative Solution
-  Excess Inventory Management