



HEF4794B

8-stage shift-and-store register LED driver

Rev. 11 — 14 August 2024

Product data sheet

1. General description

The HEF4794B is an 8-stage serial shift register. It has a storage latch associated with each stage for strobing data from the serial input (D) to the parallel LED driver outputs (QP0 to QP7). Data is shifted on the positive-going clock (CP) transitions. The data in each shift register stage is transferred to the storage register when the strobe input (STR) is HIGH. Data in the storage register appears at the outputs whenever the output enable input (OE) signal is HIGH.

Two serial outputs (QS1 and QS2) are available for cascading a number of HEF4794B devices. Serial data is available at QS1 on positive-going clock edges to allow high-speed operation in cascaded systems with a fast clock rise time. The same serial data is available at QS2 on the next negative going clock edge. This is used for cascading HEF4794B devices when the clock has a slow rise time.

It operates over a recommended V_{DD} power supply range of 3 V to 15 V referenced to V_{SS} (usually ground). Unused inputs must be connected to V_{DD} , V_{SS} , or another input.

2. Features and benefits

- Wide supply voltage range from 3.0 V to 15.0 V
- CMOS low power dissipation
- High noise immunity
- Fully static operation
- 5 V, 10 V, and 15 V parametric ratings
- Standardized symmetrical output characteristics
- Complies with JEDEC standard JESD 13-B
- ESD protection:
 - HBM: ANSI/ESDA/JEDEC JS-001 class 2 exceeds 2000 V
 - CDM: ANSI/ESDA/JEDEC JS-002 class C3 exceeds 1000 V
- Specified from -40 °C to +85 °C and -40 °C to +125 °C

3. Ordering information

Table 1. Ordering information

Type number	Package			Version
	Temperature range	Name	Description	
HEF4794BT	-40 °C to +125 °C	SO16	plastic small outline package; 16 leads; body width 3.9 mm	SOT109-1

4. Functional diagram

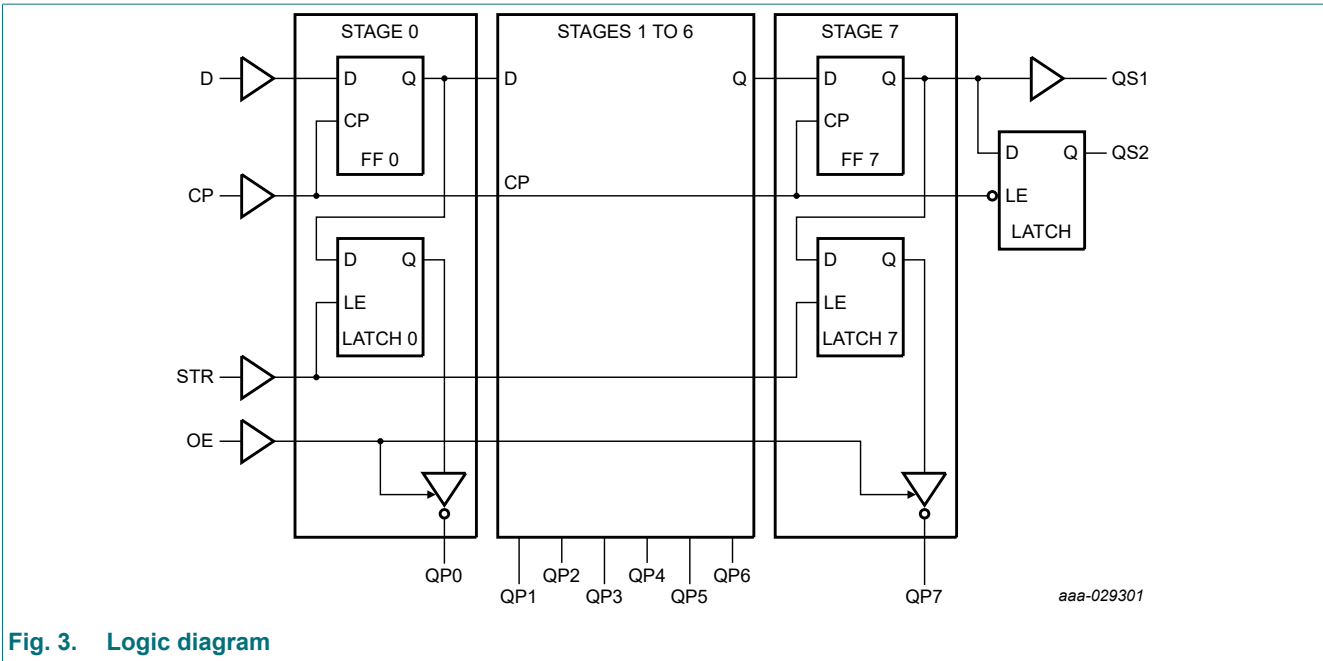
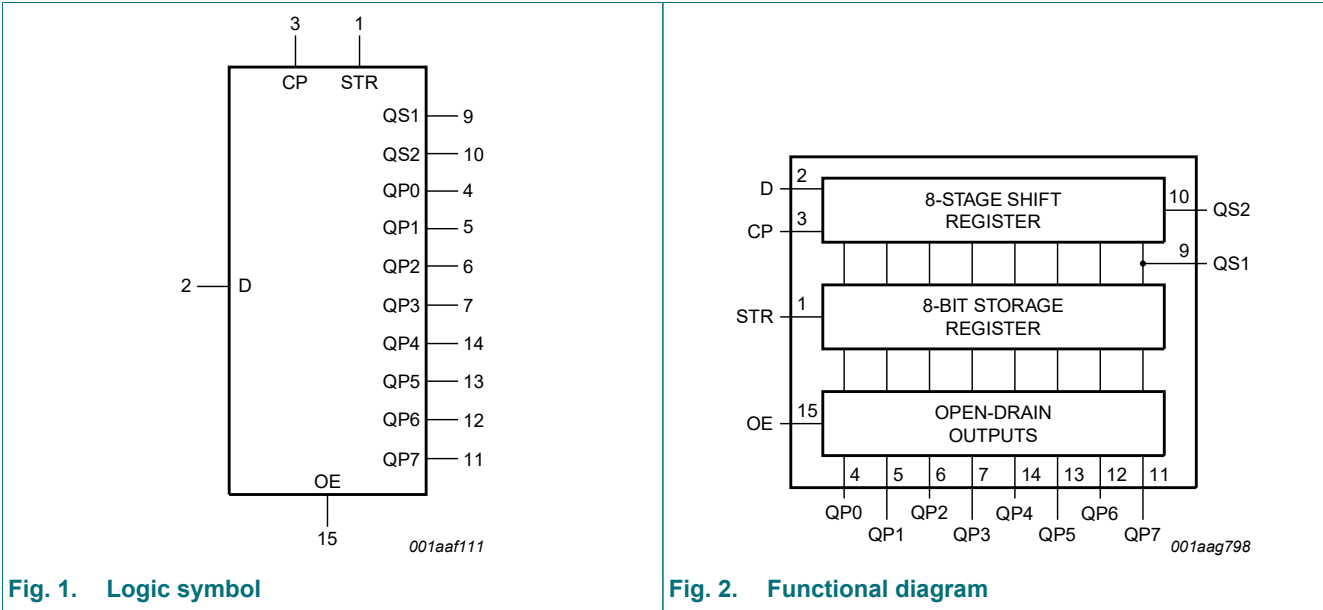

5. Pinning information

5.1. Pinning

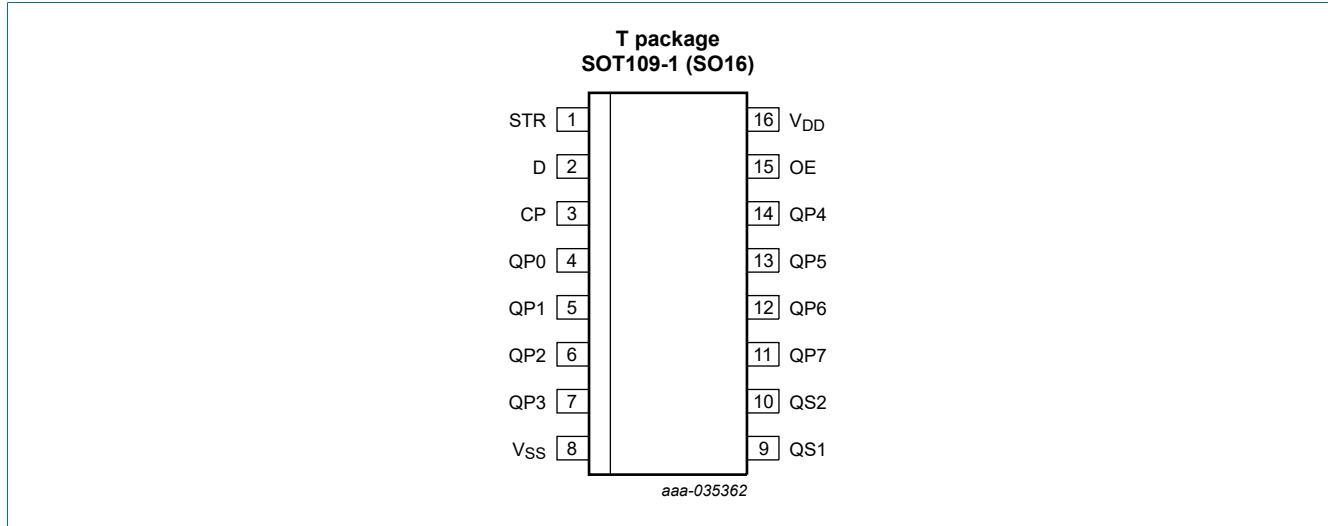

5.2. Pin description

Table 2. Pin description

Symbol	Pin	Description
D	2	serial input
QP0, QP1, QP2, QP3, QP4, QP5, QP6, QP7	4, 5, 6, 7, 14, 13, 12, 11	parallel output (open-drain)
QS1, QS2	9, 10	serial output
CP	3	clock input
STR	1	strobe input
OE	15	output enable input
V _{DD}	16	supply voltage
V _{SS}	8	ground (0 V)

6. Functional description

Table 3. Function table

H = HIGH voltage level; L = LOW voltage level; X = don't care; Z = high-impedance OFF-state;
 ↑ = LOW-to-HIGH clock transition; ↓ = HIGH-to-LOW clock transition.

Input				Parallel output		Serial output	
CP	OE	STR	D	QP0	QPn	QS1[1]	QS2[2]
↑	L	X	X	Z	Z	Q6S	no change
↓	L	X	X	Z	Z	n.c.	Q7S
↑	H	L	X	no change	no change	Q6S	no change
↑	H	H	L	Z	QPn - 1	Q6S	no change
↑	H	H	H	L	QPn - 1	Q6S	no change
↓	H	H	H	no change	no change	no change	Q7S

- [1] Q6S = the data in register stage 6 before the LOW to HIGH clock transition.
- [2] Q7S = the data in register stage 7 before the HIGH to LOW clock transition.

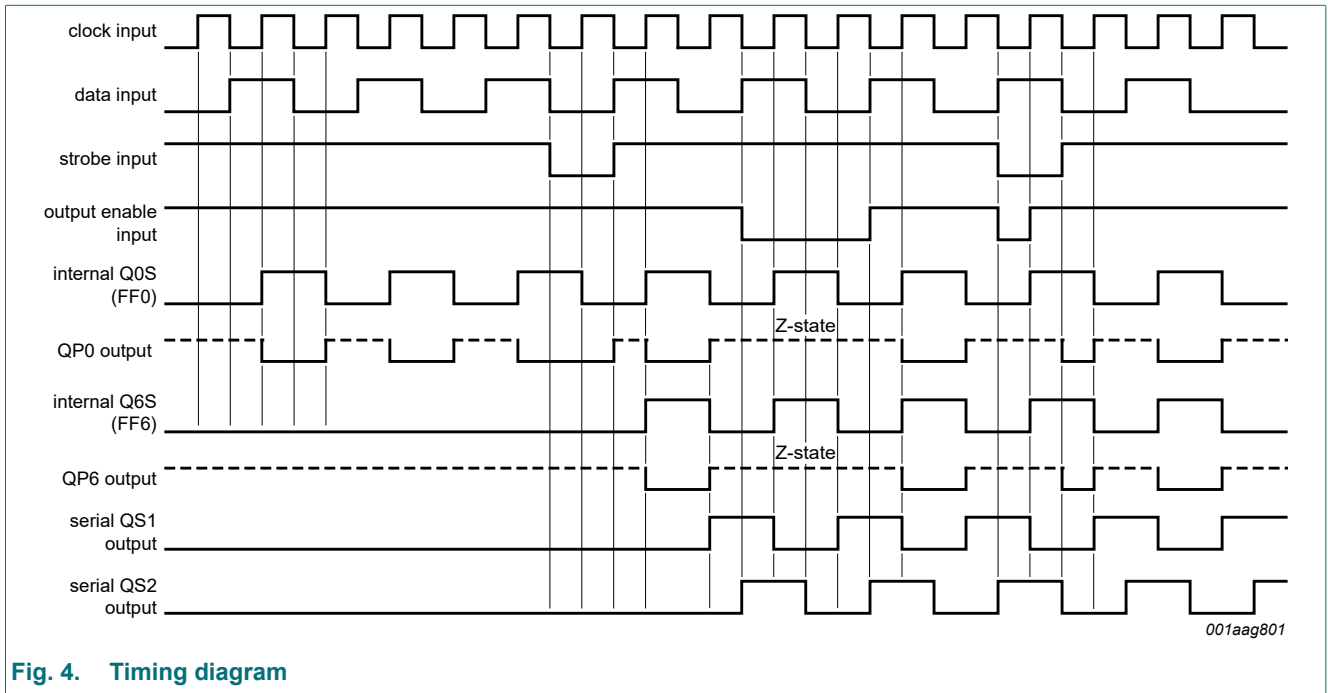

Fig. 4. Timing diagram

7. Limiting values

Table 4. Limiting values

In accordance with the Absolute Maximum Rating System (IEC 60134).

Symbol	Parameter	Conditions	Min	Max	Unit
V_{DD}	supply voltage		-0.5	+18	V
I_{IK}	input clamping current	$V_I < -0.5\text{ V}$ or $V_I > V_{DD} + 0.5\text{ V}$	-	± 10	mA
V_I	input voltage		-0.5	$V_{DD} + 0.5$	V
I_{OK}	output clamping current	QSn outputs; $V_O < -0.5\text{ V}$ or $V_O > V_{DD} + 0.5\text{ V}$	-	± 10	mA
		QPn outputs; $V_O < -0.5\text{ V}$	-	40	mA
I_I	input leakage current		-	± 10	mA
I_O	output current	QSn outputs	-	± 10	mA
		QPn outputs	-	40	mA
T_{stg}	storage temperature		-65	+150	°C
T_{amb}	ambient temperature		-40	+125	°C
P_{tot}	total power dissipation	$T_{amb} = -40\text{ °C}$ to $+125\text{ °C}$ [1]	-	500	mW
P	power dissipation	per output	-	100	mW

[1] For SOT109-1 (SO16) package: P_{tot} derates linearly with 12.4 mW/K above 110 °C.

8. Recommended operating conditions

Table 5. Recommended operating conditions

Symbol	Parameter	Conditions	Min	Max	Unit
V_{DD}	supply voltage		3	15	V
V_I	input voltage		0	V_{DD}	V
T_{amb}	ambient temperature	in free air	-40	+125	°C
$\Delta t/\Delta V$	input transition rise and fall rate	$V_{DD} = 5\text{ V}$	-	3.75	$\mu\text{s/V}$
		$V_{DD} = 10\text{ V}$	-	0.5	$\mu\text{s/V}$
		$V_{DD} = 15\text{ V}$	-	0.08	$\mu\text{s/V}$

9. Static characteristics

Table 6. Static characteristics

$V_{SS} = 0\text{ V}$; $V_I = V_{SS}$ or V_{DD} ; unless otherwise specified.

Symbol	Parameter	Conditions	V _{DD}	T _{amb} = -40 °C		T _{amb} = 25 °C		T _{amb} = 85 °C		T _{amb} = 125 °C		Unit
				Min	Max	Min	Max	Min	Max	Min	Max	
V _{IH}	HIGH-level input voltage	I _O < 1 μA	5 V	3.5	-	3.5	-	3.5	-	3.5	-	V
			10 V	7.0	-	7.0	-	7.0	-	7.0	-	V
			15 V	11.0	-	11.0	-	11.0	-	11.0	-	V
V _{IL}	LOW-level input voltage	I _O < 1 μA	5 V	-	1.5	-	1.5	-	1.5	-	1.5	V
			10 V	-	3.0	-	3.0	-	3.0	-	3.0	V
			15 V	-	4.0	-	4.0	-	4.0	-	4.0	V
V _{OH}	HIGH-level output voltage	QSn outputs; I _O < 1 μA	5 V	4.95	-	4.95	-	4.95	-	4.95	-	V
			10 V	9.95	-	9.95	-	9.95	-	9.95	-	V
			15 V	14.95	-	14.95	-	14.95	-	14.95	-	V
V _{OL}	LOW-level output voltage	QSn outputs; I _O < 1 μA	5 V	-	0.05	-	0.05	-	0.05	-	0.05	V
			10 V	-	0.05	-	0.05	-	0.05	-	0.05	V
			15 V	-	0.05	-	0.05	-	0.05	-	0.05	V
		QPn outputs; I _O < 20 mA	5 V	-	0.75	-	0.75	-	1.5	-	1.5	V
			10 V	-	0.75	-	0.75	-	1.5	-	1.5	V
			15 V	-	0.75	-	0.75	-	1.5	-	1.5	V
I _{OH}	HIGH-level output current	QSn outputs										
		V _O = 2.5 V	5 V	-	-1.7	-	-1.4	-	-1.1	-	-1.1	mA
		V _O = 4.6 V	5 V	-	-0.64	-	-0.5	-	-0.36	-	-0.36	mA
		V _O = 9.5 V	10 V	-	-1.6	-	-1.3	-	-0.9	-	-0.9	mA
		V _O = 13.5 V	15 V	-	-4.2	-	-3.4	-	-2.4	-	-2.4	mA
I _{OL}	LOW-level output current	QSn outputs										
		V _O = 0.4 V	5 V	0.64	-	0.5	-	0.36	-	0.36	-	mA
		V _O = 0.5 V	10 V	1.6	-	1.3	-	0.9	-	0.9	-	mA
		V _O = 1.5 V	15 V	4.2	-	3.4	-	2.4	-	2.4	-	mA
I _I	input leakage current		15 V	-	±0.1	-	±0.1	-	±1.0	-	±1.0	μA
I _{OZ}	OFF-state output current	QPn output is HIGH; V _O = 15 V	5 V	-	2	-	2	-	15	-	15	μA
			10 V	-	2	-	2	-	15	-	15	μA
			15 V	-	2	-	2	-	15	-	15	μA
I _{DD}	supply current	I _O = 0 A	5 V	-	5	-	5	-	150	-	150	μA
			10 V	-	10	-	10	-	300	-	300	μA
			15 V	-	20	-	20	-	600	-	600	μA
C _I	input capacitance		-	-	-	-	-	7.5	-	-	-	pF

10. Dynamic characteristics

Table 7. Dynamic characteristics

$V_{SS} = 0\text{ V}$; $T_{amb} = 25\text{ °C}$ unless otherwise specified. For test circuit, see Fig. 9.

Symbol	Parameter	Conditions	V _{DD}	Extrapolation formula[1]	Min	Typ	Max	Unit
t _{PHL}	HIGH to LOW propagation delay	CP to QS1; see Fig. 5	5 V	132 ns + (0.55 ns/pF)C _L	-	160	320	ns
			10 V	53 ns + (0.23 ns/pF)C _L	-	65	130	ns
			15 V	37 ns + (0.16 ns/pF)C _L	-	45	90	ns
		CP to QS2; see Fig. 5	5 V	92 ns + (0.55 ns/pF)C _L	-	120	240	ns
			10 V	39 ns + (0.23 ns/pF)C _L	-	50	100	ns
			15 V	32 ns + (0.16 ns/pF)C _L	-	40	80	ns
t _{PLH}	LOW to HIGH propagation delay	CP to QS1; see Fig. 5	5 V	102 ns + (0.55 ns/pF)C _L	-	130	260	ns
			10 V	44 ns + (0.23 ns/pF)C _L	-	55	110	ns
			15 V	32 ns + (0.16 ns/pF)C _L	-	40	80	ns
		CP to QS2; see Fig. 5	5 V	102 ns + (0.55 ns/pF)C _L	-	130	260	ns
			10 V	49 ns + (0.23 ns/pF)C _L	-	60	120	ns
			15 V	37 ns + (0.16 ns/pF)C _L	-	45	90	ns
t _{PZL}	OFF-state to LOW propagation delay	CP to QPn; see Fig. 5	5 V		-	240	480	ns
			10 V		-	80	160	ns
			15 V		-	55	110	ns
		STR to QPn; see Fig. 6	5 V		-	140	280	ns
			10 V		-	70	140	ns
			15 V		-	55	110	ns
t _{PLZ}	LOW to OFF-state propagation delay	CP to QPn; see Fig. 5	5 V		-	170	340	ns
			10 V		-	75	150	ns
			15 V		-	60	120	ns
		STR to QPn; see Fig. 6	5 V		-	100	200	ns
			10 V		-	40	100	ns
			15 V		-	35	70	ns
t _{en}	enable time	OE to QPn; see Fig. 7	5 V	[2]	-	100	200	ns
			10 V		-	55	110	ns
			15 V		-	50	100	ns
t _{dis}	disable time	OE to QPn; see Fig. 7	5 V	[2]	-	80	160	ns
			10 V		-	40	80	ns
			15 V		-	30	60	ns
t _t	transition time	QS1, QS2; see Fig. 5	5 V	[3] 35 ns + (1.00 ns/pF)C _L	-	85	170	ns
			10 V	19 ns + (0.42 ns/pF)C _L	-	40	80	ns
			15 V	16 ns + (0.28 ns/pF)C _L	-	30	60	ns
t _w	pulse width	CP LOW and HIGH; see Fig. 5	5 V		60	30	-	ns
			10 V		30	15	-	ns
			15 V		24	12	-	ns
		STR HIGH; see Fig. 6	5 V		80	40	-	ns
			10 V		60	30	-	ns
			15 V		24	12	-	ns

8-stage shift-and-store register LED driver

Symbol	Parameter	Conditions	V _{DD}	Extrapolation formula[1]	Min	Typ	Max	Unit
t _{su}	set-up time	D to CP; see Fig. 8	5 V		60	30	-	ns
			10 V		20	10	-	ns
			15 V		15	5	-	ns
t _h	hold time	D to CP; see Fig. 8	5 V		+5	-15	-	ns
			10 V		20	5	-	ns
			15 V		20	5	-	ns
f _{clk(max)}	maximum clock frequency	CP; see Fig. 5	5 V		5	10	-	MHz
			10 V		11	22	-	MHz
			15 V		14	28	-	MHz

- [1] The typical values of the propagation delay and transition times are calculated from the extrapolation formulas shown (C_L in pF).
- [2] t_{en} is the same as t_{PZL} and t_{dis} is the same as t_{PLZ}
- [3] t_t is the same as t_{TLH} and t_{THL}

Table 8. Dynamic power dissipation

P_D can be calculated from the formulas shown. V_{SS} = 0 V; t_r = t_f ≤ 20 ns; T_{amb} = 25 °C.

Symbol	Parameter	V _{DD}	Typical formula	Where
P _D	dynamic power dissipation	5 V	$P_D = 1200 \times f_i + \Sigma(f_o \times C_L) \times V_{DD}^2 \mu W$	f _i = input frequency in MHz; f _o = output frequency in MHz; C _L = output load capacitance in pF; Σ(f _o × C _L) = sum of the outputs; V _{DD} = supply voltage in V.
		10 V	$P_D = 5550 \times f_i + \Sigma(f_o \times C_L) \times V_{DD}^2 \mu W$	
		15 V	$P_D = 15000 \times f_i + \Sigma(f_o \times C_L) \times V_{DD}^2 \mu W$	

10.1. Waveforms and test circuit

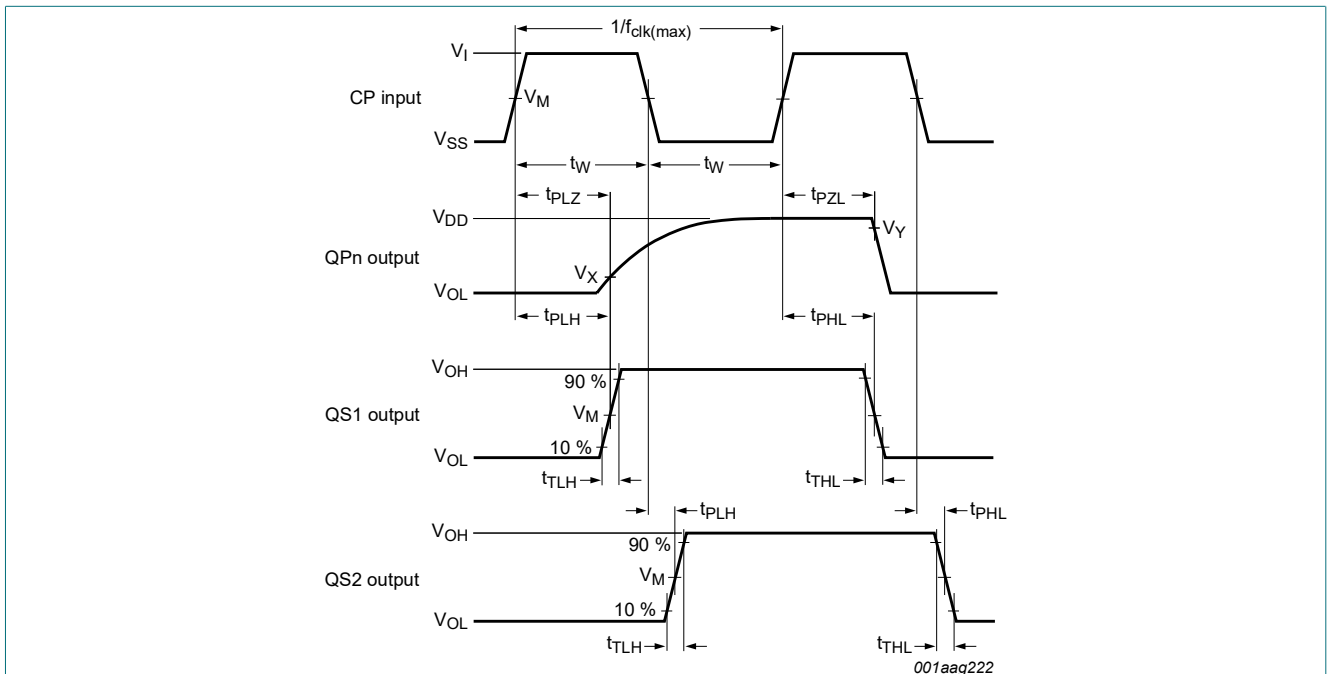

Parallel output measurement points are given in Table 9.
V_{OL} and V_{OH} are typical output voltage levels that occur with the output load.

Fig. 5. Propagation delay clock (CP) to output (QPn, QS1, QS2), clock pulse width and maximum clock frequency

Table 9. Measurement points

Supply	Input	Output		
V_{DD}	V_M	V_M	V_X	V_Y
5 V to 15 V	$0.5 \times V_{DD}$	$0.5 \times V_{DD}$	$0.1 \times V_O$	$0.9 \times V_O$

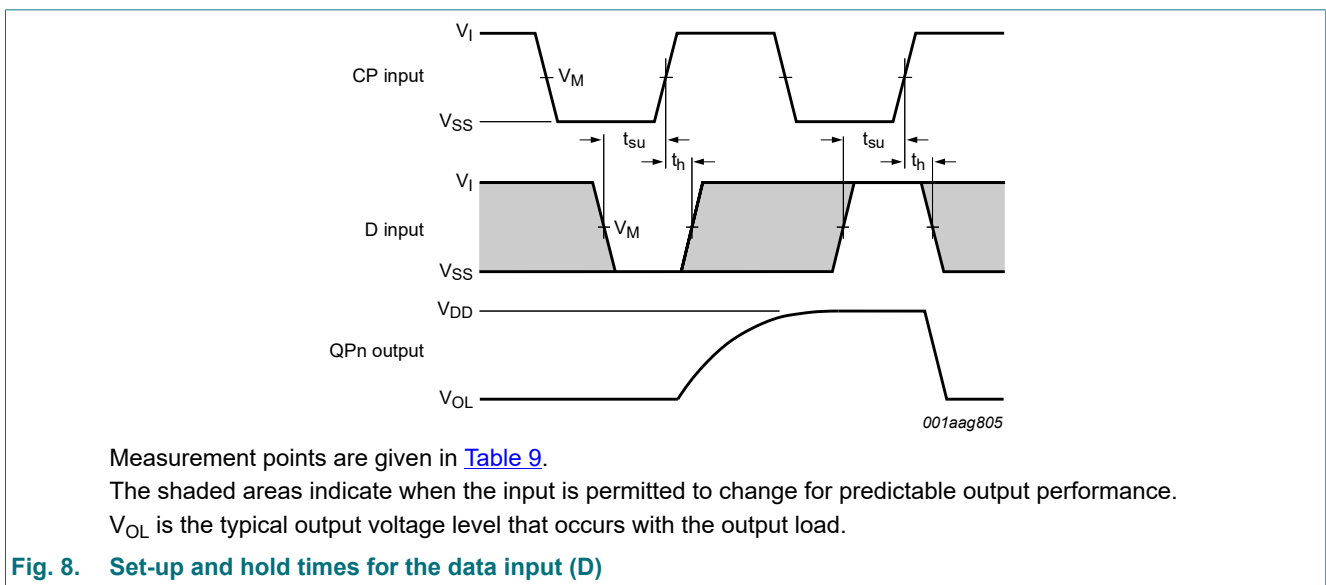
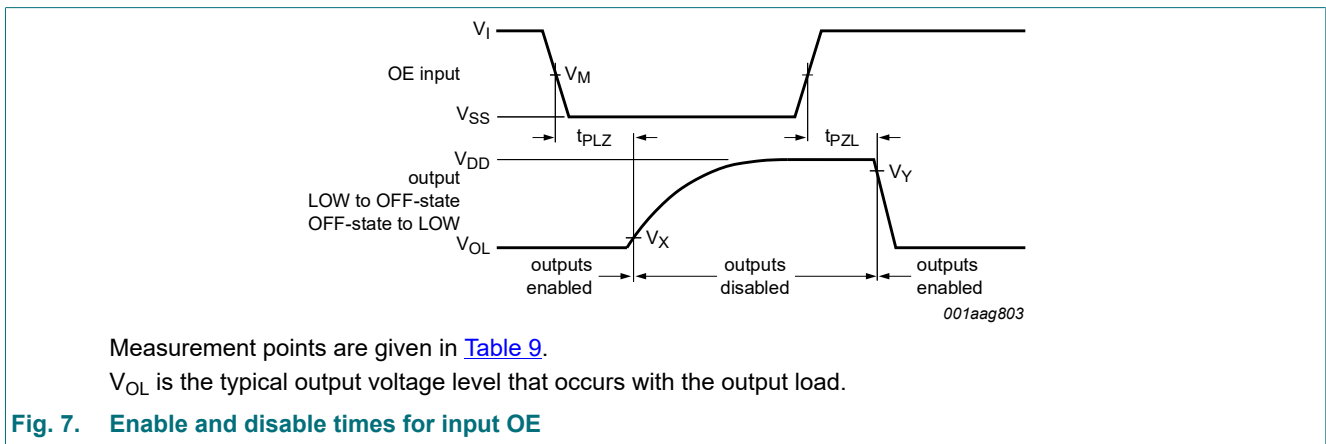
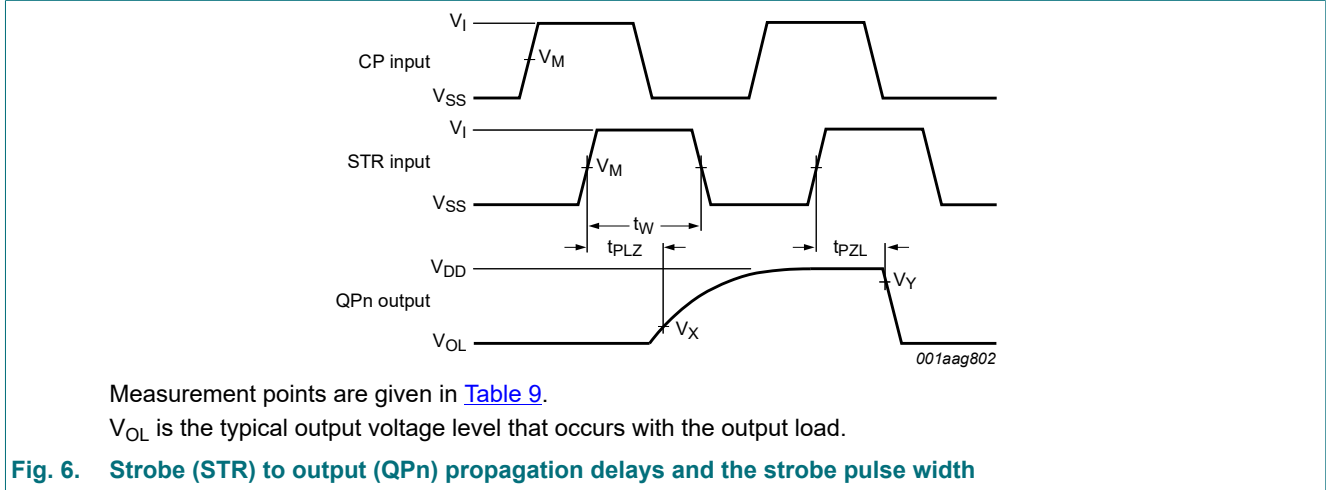

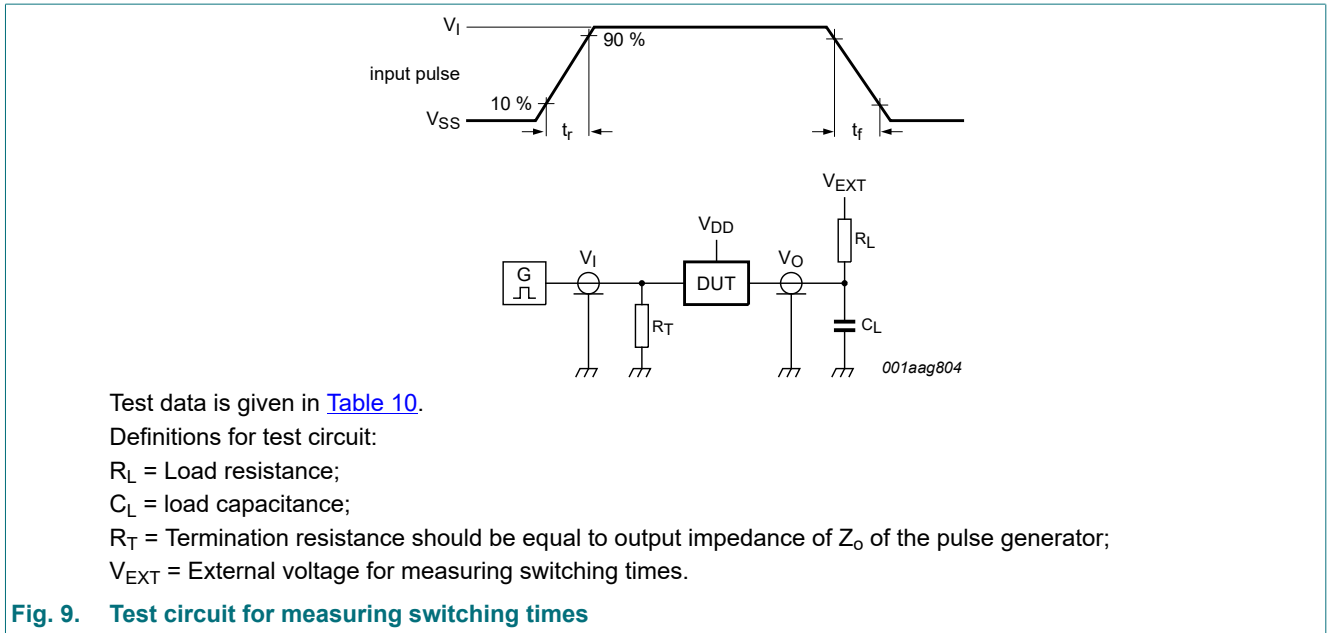
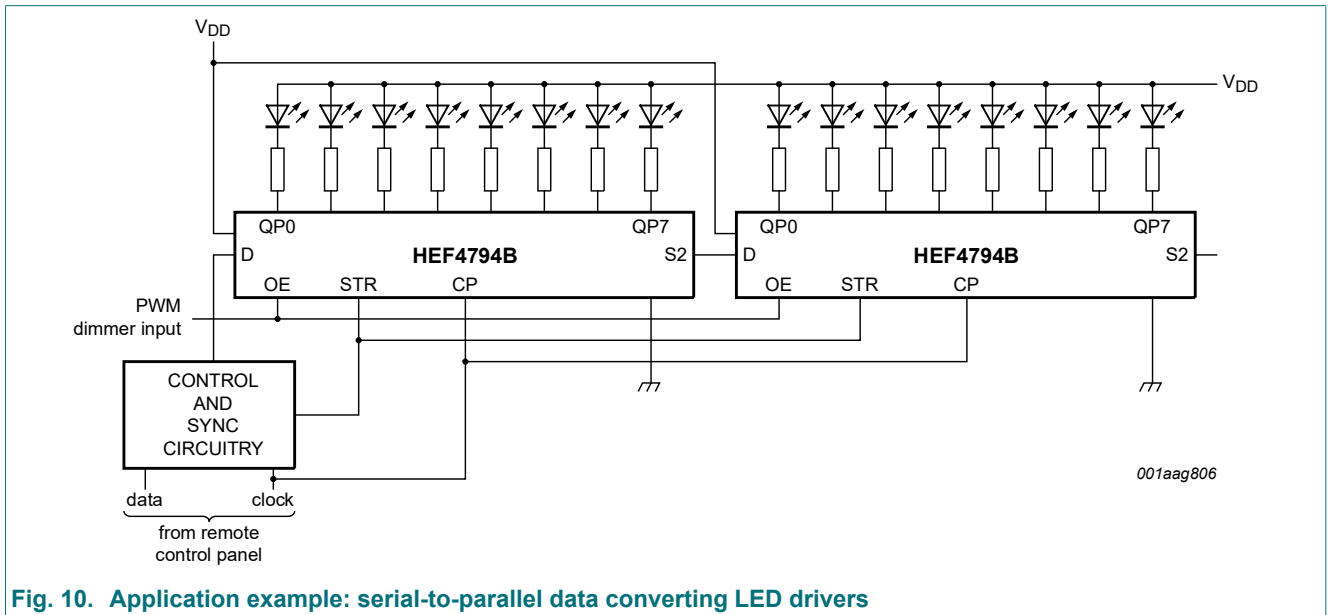

Table 10. Test data

Supply	Input	V_{EXT}	Load
V_{DD}	V_I	t_r, t_f	t_{PLZ}, t_{PZL} t_{PLH}, t_{PHL}
5 V to 15 V	V_{DD}	≤ 20 ns	V_{DD} open C_L R_L
			50 pF 1 k Ω

11. Application information



12. Package outline

SO16: plastic small outline package; 16 leads; body width 3.9 mm

SOT109-1

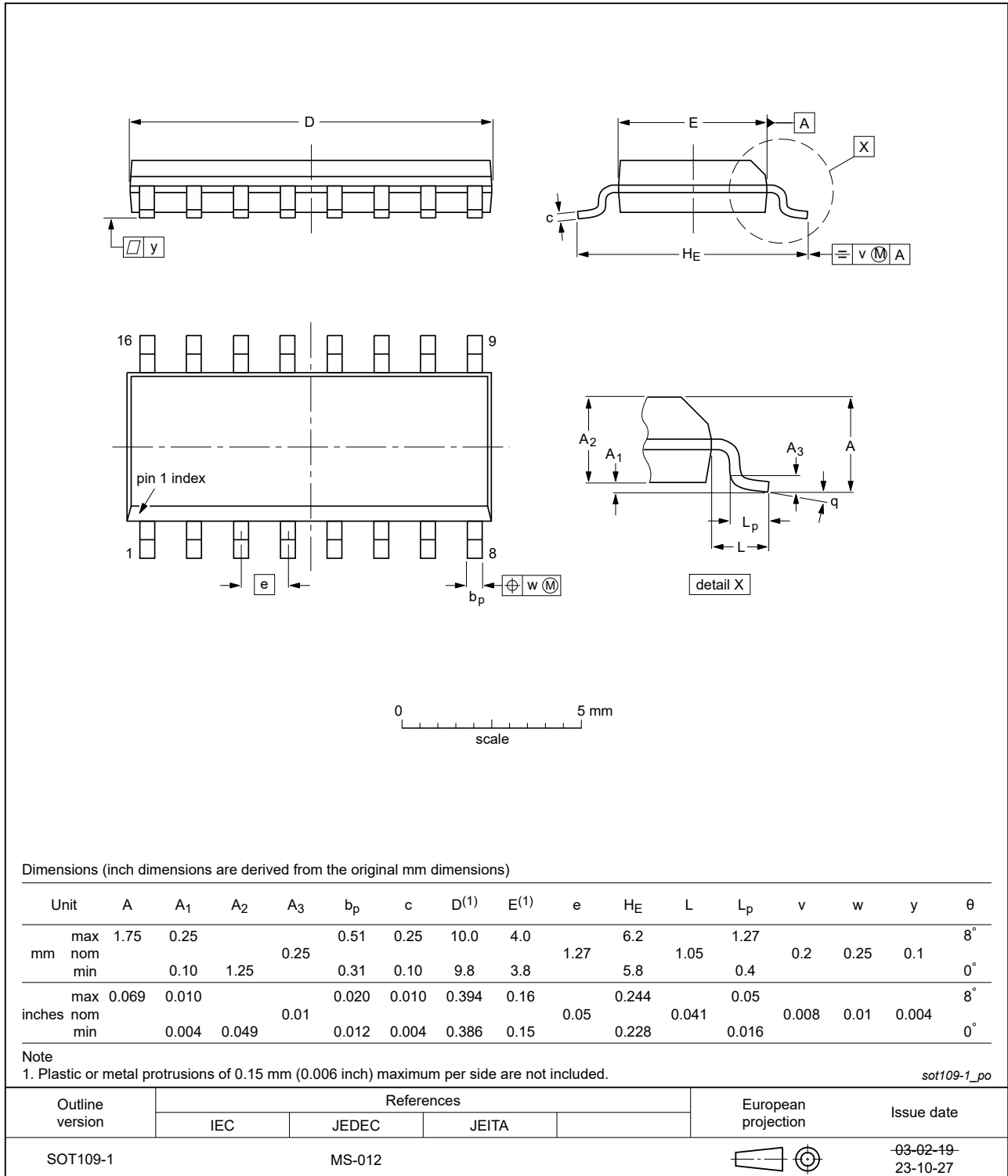

Fig. 11. Package outline SOT109-1 (SO16)

13. Abbreviations

Table 11. Abbreviations

Acronym	Description
ANSI	American National Standards Institute
CDM	Charged Device Model
DUT	Device Under Test
ESD	ElectroStatic Discharge
ESDA	ElectroStatic Discharge Association
HBM	Human Body Model
JEDEC	Joint Electron Device Engineering Council

14. Revision history

Table 12. Revision history

Document ID	Release date	Data sheet status	Change notice	Supersedes
HEF4794B v.11	20240814	Product data sheet	-	HEF4794B v.10
Modifications:	<ul style="list-style-type: none"> • Section 2: ESD specification updated according to the latest JEDEC standard. • Fig. 11: Aligned SO package outline drawing to JEDEC MS-012 			
HEF4794B v.10	20220106	Product data sheet	-	HEF4794B v.9
Modifications:	<ul style="list-style-type: none"> • Section 2 updated and Section 13 added. 			
HEF4794B v.9	20181107	Product data sheet	-	HEF4794B v.8
Modifications:	<ul style="list-style-type: none"> • The format of this data sheet has been redesigned to comply with the identity guidelines of Nexperia. • Legal texts have been adapted to the new company name where appropriate. • Fig. 3 and Fig. 4 corrected. 			
HEF4794B v.8	20160404	Product data sheet	-	HEF4794B v.7
Modifications:	<ul style="list-style-type: none"> • Type number HEF4794BP (SOT38-4) removed. 			
HEF4794B v.7	20111116	Product data sheet	-	HEF4794B v.6
Modifications:	<ul style="list-style-type: none"> • Section Applications removed • Table 6: I_{OH} minimum values changed to maximum added the unit pF for C_I 			
HEF4794B v.6	20100901	Product data sheet	-	HEF4794B v.5
HEF4794B v.5	20100402	Product data sheet	-	HEF4794B v.4
HEF4794B v.4	20091222	Product data sheet	-	HEF4794B v.3
HEF4794B v.3	20080812	Product data sheet	-	HEF4794B v.2
HEF4794B v.2	19990630	Product specification	-	HEF4794B v.1
HEF4794B v.1	19940701	Product specification	-	-

15. Legal information

Data sheet status

Document status [1][2]	Product status [3]	Definition
Objective [short] data sheet	Development	This document contains data from the objective specification for product development.
Preliminary [short] data sheet	Qualification	This document contains data from the preliminary specification.
Product [short] data sheet	Production	This document contains the product specification.

- [1] Please consult the most recently issued document before initiating or completing a design.
- [2] The term 'short data sheet' is explained in section "Definitions".
- [3] The product status of device(s) described in this document may have changed since this document was published and may differ in case of multiple devices. The latest product status information is available on the internet at <https://www.nexperia.com>.

Definitions

Draft — The document is a draft version only. The content is still under internal review and subject to formal approval, which may result in modifications or additions. Nexperia does not give any representations or warranties as to the accuracy or completeness of information included herein and shall have no liability for the consequences of use of such information.

Short data sheet — A short data sheet is an extract from a full data sheet with the same product type number(s) and title. A short data sheet is intended for quick reference only and should not be relied upon to contain detailed and full information. For detailed and full information see the relevant full data sheet, which is available on request via the local Nexperia sales office. In case of any inconsistency or conflict with the short data sheet, the full data sheet shall prevail.

Product specification — The information and data provided in a Product data sheet shall define the specification of the product as agreed between Nexperia and its customer, unless Nexperia and customer have explicitly agreed otherwise in writing. In no event however, shall an agreement be valid in which the Nexperia product is deemed to offer functions and qualities beyond those described in the Product data sheet.

Disclaimers

Limited warranty and liability — Information in this document is believed to be accurate and reliable. However, Nexperia does not give any representations or warranties, expressed or implied, as to the accuracy or completeness of such information and shall have no liability for the consequences of use of such information. Nexperia takes no responsibility for the content in this document if provided by an information source outside of Nexperia.

In no event shall Nexperia be liable for any indirect, incidental, punitive, special or consequential damages (including - without limitation - lost profits, lost savings, business interruption, costs related to the removal or replacement of any products or rework charges) whether or not such damages are based on tort (including negligence), warranty, breach of contract or any other legal theory.

Notwithstanding any damages that customer might incur for any reason whatsoever, Nexperia's aggregate and cumulative liability towards customer for the products described herein shall be limited in accordance with the Terms and conditions of commercial sale of Nexperia.

Right to make changes — Nexperia reserves the right to make changes to information published in this document, including without limitation specifications and product descriptions, at any time and without notice. This document supersedes and replaces all information supplied prior to the publication hereof.

Suitability for use — Nexperia products are not designed, authorized or warranted to be suitable for use in life support, life-critical or safety-critical systems or equipment, nor in applications where failure or malfunction of an Nexperia product can reasonably be expected to result in personal

injury, death or severe property or environmental damage. Nexperia and its suppliers accept no liability for inclusion and/or use of Nexperia products in such equipment or applications and therefore such inclusion and/or use is at the customer's own risk.

Quick reference data — The Quick reference data is an extract of the product data given in the Limiting values and Characteristics sections of this document, and as such is not complete, exhaustive or legally binding.

Applications — Applications that are described herein for any of these products are for illustrative purposes only. Nexperia makes no representation or warranty that such applications will be suitable for the specified use without further testing or modification.

Customers are responsible for the design and operation of their applications and products using Nexperia products, and Nexperia accepts no liability for any assistance with applications or customer product design. It is customer's sole responsibility to determine whether the Nexperia product is suitable and fit for the customer's applications and products planned, as well as for the planned application and use of customer's third party customer(s). Customers should provide appropriate design and operating safeguards to minimize the risks associated with their applications and products.

Nexperia does not accept any liability related to any default, damage, costs or problem which is based on any weakness or default in the customer's applications or products, or the application or use by customer's third party customer(s). Customer is responsible for doing all necessary testing for the customer's applications and products using Nexperia products in order to avoid a default of the applications and the products or of the application or use by customer's third party customer(s). Nexperia does not accept any liability in this respect.

Limiting values — Stress above one or more limiting values (as defined in the Absolute Maximum Ratings System of IEC 60134) will cause permanent damage to the device. Limiting values are stress ratings only and (proper) operation of the device at these or any other conditions above those given in the Recommended operating conditions section (if present) or the Characteristics sections of this document is not warranted. Constant or repeated exposure to limiting values will permanently and irreversibly affect the quality and reliability of the device.

Terms and conditions of commercial sale — Nexperia products are sold subject to the general terms and conditions of commercial sale, as published at <http://www.nexperia.com/profile/terms>, unless otherwise agreed in a valid written individual agreement. In case an individual agreement is concluded only the terms and conditions of the respective agreement shall apply. Nexperia hereby expressly objects to applying the customer's general terms and conditions with regard to the purchase of Nexperia products by customer.

No offer to sell or license — Nothing in this document may be interpreted or construed as an offer to sell products that is open for acceptance or the grant, conveyance or implication of any license under any copyrights, patents or other industrial or intellectual property rights.

Export control — This document as well as the item(s) described herein may be subject to export control regulations. Export might require a prior authorization from competent authorities.

Non-automotive qualified products — Unless this data sheet expressly states that this specific Nexperia product is automotive qualified, the product is not suitable for automotive use. It is neither qualified nor tested in accordance with automotive testing or application requirements. Nexperia accepts no liability for inclusion and/or use of non-automotive qualified products in automotive equipment or applications.

In the event that customer uses the product for design-in and use in automotive applications to automotive specifications and standards, customer (a) shall use the product without Nexperia's warranty of the product for such automotive applications, use and specifications, and (b) whenever customer uses the product for automotive applications beyond Nexperia's specifications such use shall be solely at customer's own risk, and (c) customer fully indemnifies Nexperia for any liability, damages or failed product claims resulting from customer design and use of the product for automotive applications beyond Nexperia's standard warranty and Nexperia's product specifications.

Translations — A non-English (translated) version of a document is for reference only. The English version shall prevail in case of any discrepancy between the translated and English versions.

Trademarks

Notice: All referenced brands, product names, service names and trademarks are the property of their respective owners.

Contents

1. General description	1
2. Features and benefits	1
3. Ordering information	1
4. Functional diagram	2
5. Pinning information	3
5.1. Pinning.....	3
5.2. Pin description.....	3
6. Functional description	4
7. Limiting values	5
8. Recommended operating conditions	5
9. Static characteristics	6
10. Dynamic characteristics	7
10.1. Waveforms and test circuit.....	8
11. Application information	10
12. Package outline	11
13. Abbreviations	12
14. Revision history	12
15. Legal information	13

© Nexperia B.V. 2024. All rights reserved

For more information, please visit: <http://www.nexperia.com>

For sales office addresses, please send an email to: salesaddresses@nexperia.com

Date of release: 14 August 2024

Looking for pricing, stock, or lifecycle information?

Click below to explore more details on WIN SOURCE:

 [View HEF4794BT,112 on WIN SOURCE](#)

 [Nexperia USA Inc. Information](#)

Optimize Your Supply Chain with WIN SOURCE Solutions

-  Global Sourcing Solution
-  Obsolete Management
-  Cost Control Management
-  Shortage Management
-  Alternative Solution
-  Excess Inventory Management