



**THE DATASHEET OF
RF3417E**



- **Ideal Front-End Filter for European Wireless Receivers**
- **Low-Loss, Coupled-Resonator Quartz Design**
- **Simple External Impedance Matching**
- **Complies with Directive 2011/65/EU (RoHS)**
- **Tape and Reel Standard per ANSI/EIA-481**
- **Moisture Sensitivity Level: 1**
- **AEC-Q200 Qualified**

The RF3417E is a low-loss, compact, and economical surface-acoustic-wave (SAW) filter designed to provide front-end selectivity in 315.0 MHz receivers. Receiver designs using this filter include superhet with 10.7 MHz or 500 kHz IF, direct conversion and superregen. Typical applications of these receivers are wireless remote-control and security devices operating in Europe under ETSI I-ETS 300 220, in Germany under FTZ 17 TR 2100, in the United Kingdom under DTI MPT 1340 (for automotive only), in France under PTT Specifications ST/PAA/TPA/AGH/1542, and in Scandinavia.

This coupled-resonator filter (CRF) uses selective null placement to provide suppression, typically greater than 40 dB, of the LO and image spurious responses of superhet receivers with 10.7 MHz IF. RFMI's advanced SAW design and fabrication technology is utilized to achieve high performance and very low loss with simple external impedance matching (not included).

RF3417E

**315.00 MHz
SAW Filter**

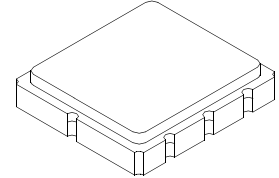

**SM3030-6 Case
3.0 x 3.0**

Characteristic	Sym	Notes	Minimum	Typical	Maximum	Units
Center Frequency @ 25°C Absolute Frequency	f_c		314.900	315.00	315.100	MHz
Insertion Loss	IL			1.8	2.5	dB
3 dB Bandwidth	BW ₃		525	600	675	kHz
1 dB Bandwidth	BW ₁			450		kHz
Rejection		10 - 275 MHz	40	60		dB
		275 - 306 MHz	40	45		
		306 - 313.2 MHz	25	30		
		313.2 - 314.2 MHz	7	15		
		315.8 - 317 MHz	12	15		
		317 - 321.8 MHz	25	30		
		321.8 - 326 MHz	12	17		
		326 - 355 MHz	37	45		
355 - 1000 MHz	50	55				
Temperature Freq. Temp. Coefficient	FTC			0.032		ppm/°C ²
Turnover Temperature	To		10		40	°C
Frequency Aging Absolute Value during the First Year	fA			<±10		ppm/yr
Impedance @ f_c	Input $Z_{IN} = R_{IN}/C_{IN}$	Z_{IN}	3.7kΩ // 2.03pF			
	Output $Z_{OUT} = R_{OUT}/C_{OUT}$	Z_{OUT}	5.4kΩ // 2.17pF			
Lid Symbolization (in addition to Lot and/or Date Codes)	696, YWWS					
Standard Reel Quantity 7 Inch Reel	500 Pieces/Reel					
Standard Reel Quantity 13 Inch Reel	3000 Pieces/Reel					



CAUTION: Electrostatic Sensitive Device. Observe precautions for handling.

NOTES:

1. The design, manufacturing process, and specifications of this device are subject to change.
2. US or International patents may apply.
3. RoHS compliant from the first date of manufacture.

17 Apr 2007 11:50:38

CH1 S11 1 UFS

1: 50.721 Ω 3.2051 Ω 1.6194 nH 315.000 000 MHz

h_p
RF3417E DEMO
FULL 2 PORTS CAL.

Cor

Full

↑

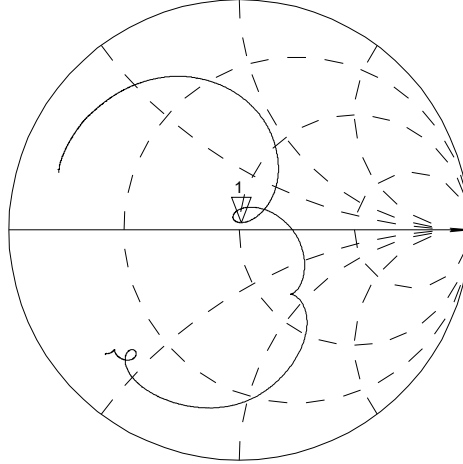

CH2 S22 1 UFS

1: 46.738 Ω -14.436 Ω 35.001 pF 315.000 000 MHz

Cor
Full

↑

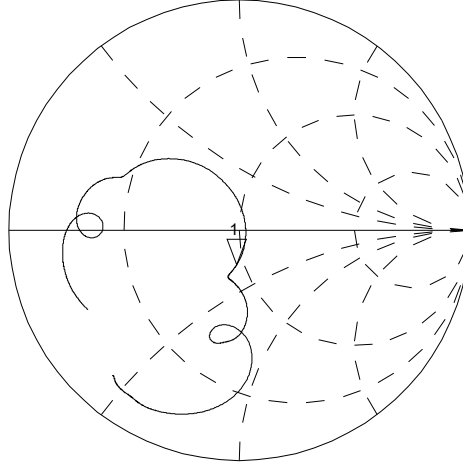

CENTER 315.000 000 MHz

SPAN 2.000 000 MHz

17 Apr 2007 11:50:52

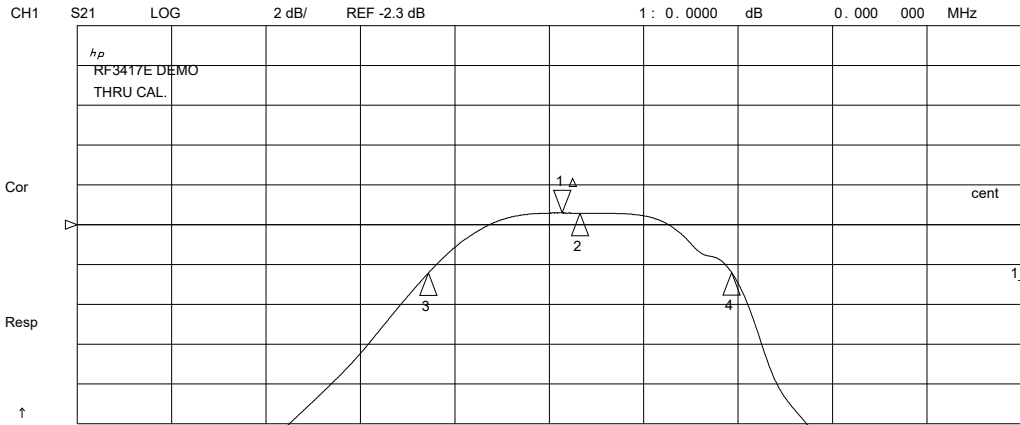

CH1 Markers
 Max Δ REF=1
 BW: .641618 MHz
 : 315.065431 MHz
 Q: 491.05
 1 loss : -1.7003 dB

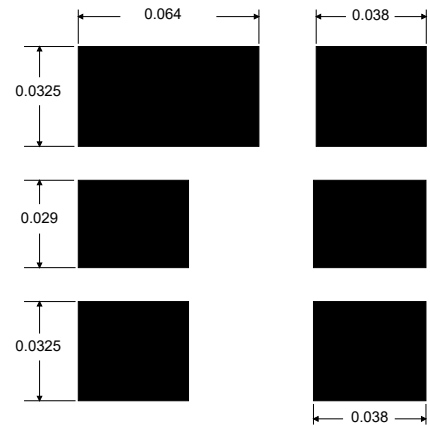
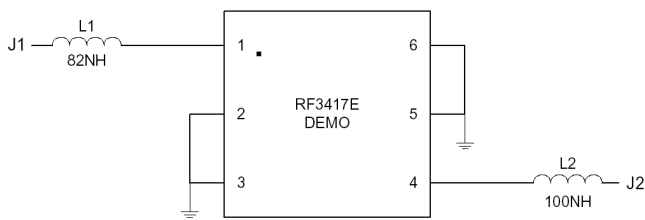
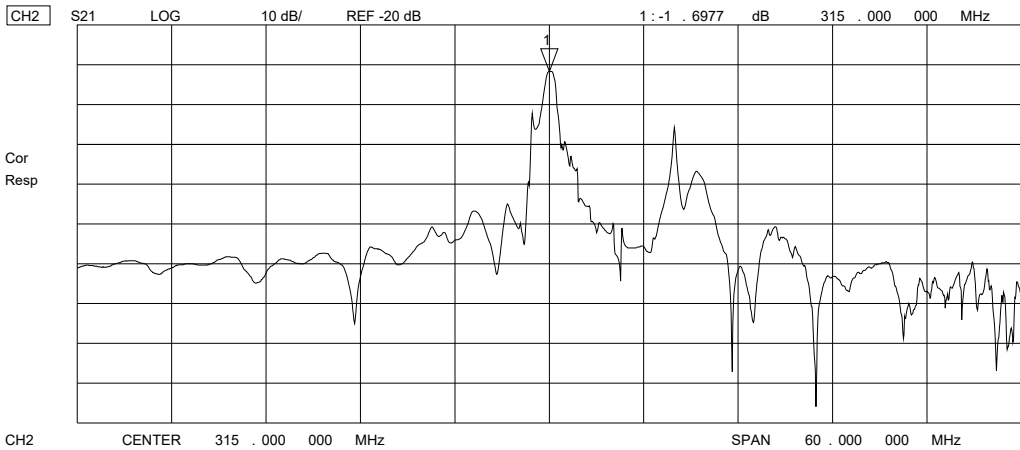

PCB Pad Layout in Inches

Rating	Value	Units
Input Power Level	10	dBm
DC Voltage	12	VDC
Storage Temperature	-40 to +125	°C
Operable Temperature Range	-40 to +125	°C
Soldering Temperature	(10 seconds / 5 cycles max.)	260 °C

Electrical Connections

Pin	Connection
1	Input Ground
2	Input
3	Ground
4	Output Ground
5	Output
6	Ground

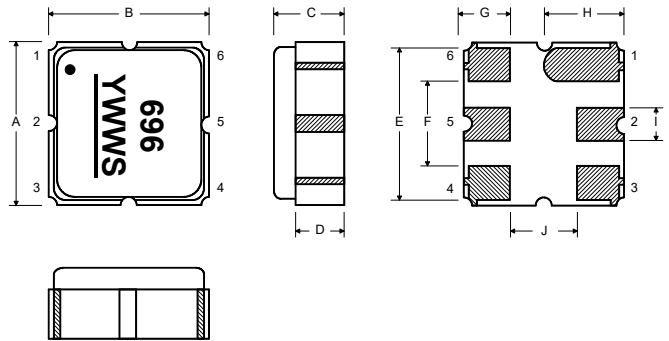

Case Dimensions

Dimension	mm			Inches		
	Min	Nom	Max	Min	Nom	Max
A	2.87	3.0	3.13	0.113	0.118	0.123
B	2.87	3.0	3.13	0.113	0.118	0.123
C	1.12	1.25	1.38	0.044	0.049	0.054
D	0.77	0.90	1.03	0.030	0.035	0.040
E	2.67	2.80	2.93	0.105	0.110	0.115
F	1.47	1.6	1.73	0.058	0.063	0.068
G	0.72	0.85	0.98	0.028	0.033	0.038
H	1.37	1.5	1.63	0.054	0.059	0.064
I	0.47	0.60	0.73	0.019	0.024	0.029
J	1.17	1.30	1.43	0.046	0.051	0.056

Matching Circuit to 50Ω

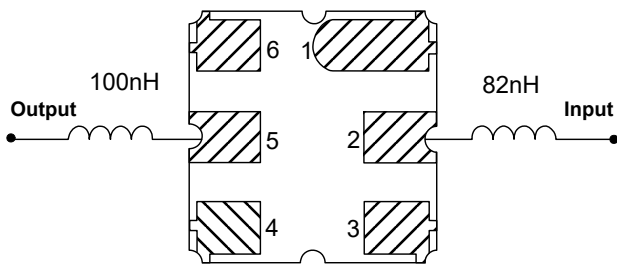

Optional Electrical Connections

Pin	Connection
1	Input
2	Input Ground
3	Ground
4	Output
5	Output Ground
6	Ground

Matching Circuit to 50Ω

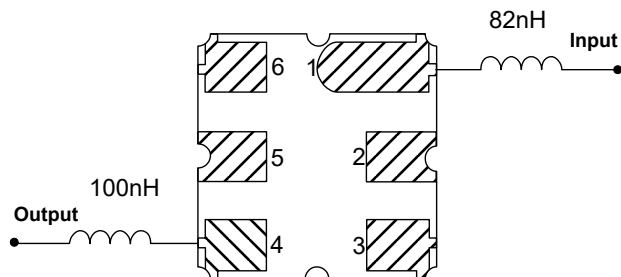



Recommended Reflow Profile

1. Preheating shall be fixed at 150~180°C for 60~90 seconds.
2. Ascending time to preheating temperature 150°C shall be 30 seconds min.
3. Heating shall be fixed at 220°C for 50~80 seconds and at 260°C +0/-5°C peak (10 seconds).
4. Time: 5 times maximum.



Looking for pricing, stock, or lifecycle information?

Click below to explore more details on WIN SOURCE:

-  [View RF3417E on WIN SOURCE](#)
-  [RF Monolithics, Inc Information](#)

Optimize Your Supply Chain with WIN SOURCE Solutions

-  Global Sourcing Solution
-  Obsolete Management
-  Cost Control Management
-  Shortage Management
-  Alternative Solution
-  Excess Inventory Management