



**THE DATASHEET OF  
RO3118D**



- **Ideal for 318 MHz Remote Control and Wireless Security Transmitters**
- **Very Low Series Resistance**
- **Quartz Stability**
- **Complies with Directive 2002/95/EC (RoHS)**
- **Tape and Reel Standard per ANSI/EIA-481**

The RO3118D is a true one-port, surface-acoustic-wave (SAW) resonator in a surface-mount ceramic case. It provides reliable, fundamental-mode, quartz frequency stabilization of transmitters and local oscillators operating at 318 MHz.

**Absolute Maximum Ratings**

Rating	Value	Units
Input Power Level	0	dBm
DC Voltage	12	VDC
Storage Temperature	-40 to +85	°C
Soldering Temperature (10 seconds / 5 cycles maximum)	260	°C

**RO3118D**

**318.0 MHz  
SAW  
Resonator**

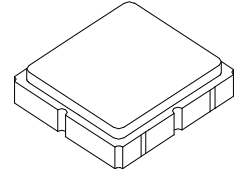

**SM3838-6 Case**

**Electrical Characteristics**

Characteristic		Sym	Notes	Minimum	Typical	Maximum	Units
Frequency, +25 °C	Absolute Frequency	$f_C$		317.925		318.075	MHz
	Tolerance from 318.0 MHz	$\Delta f_C$				±75	kHz
Insertion Loss		IL			1.4	2.0	dB
Quality Factor	Unloaded Q	$Q_U$			12900		
	50Ω Loaded Q	$Q_L$			1800		
Temperature Stability	Turnover Temperature	$T_O$		10	25	40	°C
	Turnover Frequency	$f_O$			$f_C$		
	Frequency Temperature Coefficient	FTC			0.032		ppm/°C <sup>2</sup>
Frequency Aging	Absolute Value during the First Year	$ f_A $			10		ppm/yr
DC Insulation Resistance between Any Two Terminals				1.0			MΩ
RF Equivalent RLC Model	Motional Resistance	$R_M$			16		Ω
	Motional Inductance	$L_M$			101		μH
	Motional Capacitance	$C_M$			2.4		fF
	Shunt Static Capacitance	$C_O$			2.8		pF
Test Fixture Shunt Inductance		$L_{TEST}$			86		nH
Lid Symbolization: Y = Year, WW = Week, S = Shift)				716, YWWS			
Standard Reel Quantity	Reel Size 7 Inch			500 Pieces / Reel			
	Reel Size 13 Inch			3000 Pieces / Reel			

 **CAUTION: Electrostatic Sensitive Device. Observe precautions for handling.**

**NOTES:**

1. The design, manufacturing process, and specifications of this device are subject to change.
2. US or International patents may apply.
3. RoHS compliant from the first date of manufacture.

## Electrical Connections

The SAW resonator is bidirectional and may be installed with either orientation. The two terminals are interchangeable and unnumbered. The callout NC indicates no internal connection. The NC pads assist with mechanical positioning and stability. External grounding of the NC pads is recommended to help reduce parasitic capacitance in the circuit.

Pin	Connection
1	NC
2	Terminal
3	NC
4	NC
5	NC
6	Terminal
7	NC
8	NC

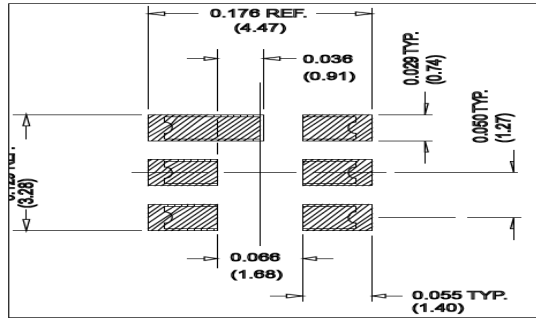
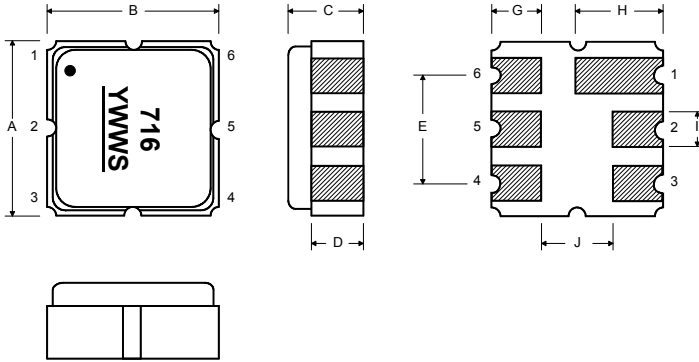

## Case Dimensions

Dimension	mm			Inches		
	Min	Nom	Max	Min	Nom	Max
A	3.60	3.80	4.00	0.142	0.150	0.157
B	3.60	3.80	4.00	0.142	0.150	0.157
C	1.10	1.30	1.50	0.043	0.050	0.060
D	0.95	1.10	1.25	0.037	0.043	0.049
E	2.39	2.54	2.69	0.094	0.100	0.106
G	0.90	1.00	1.10	0.035	0.040	0.043
H	1.90	2.00	2.10	0.748	0.079	0.083
I	0.50	0.60	0.70	0.020	0.024	0.028
J	1.70	1.80	1.90	0.067	0.071	0.075

## Equivalent RLC Model

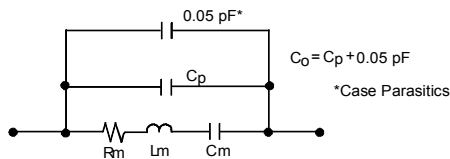

## Parameter Test Circuit

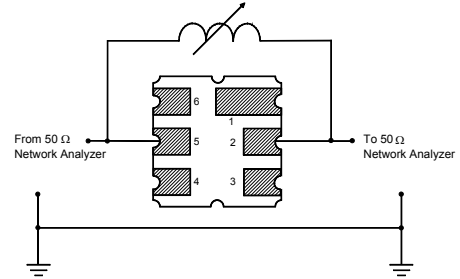

## Power Test Circuit

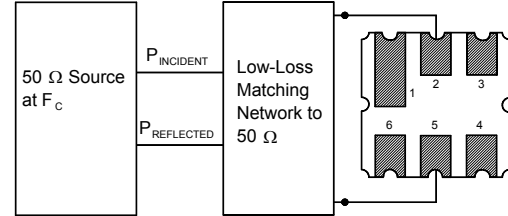

## Example Application Circuits

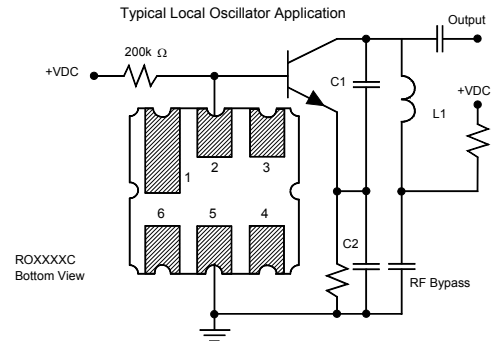
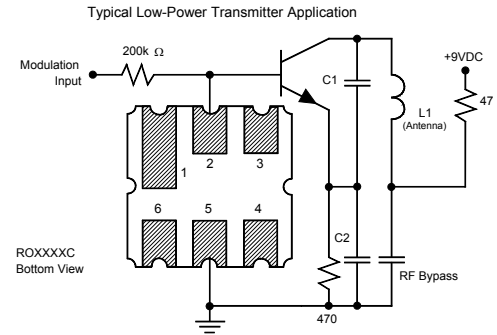

## Temperature Characteristics

The curve shown on the right accounts for resonator contribution only and does not include LC component temperature contributions.

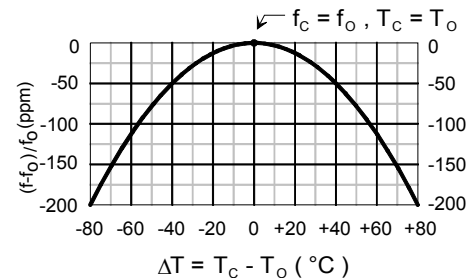

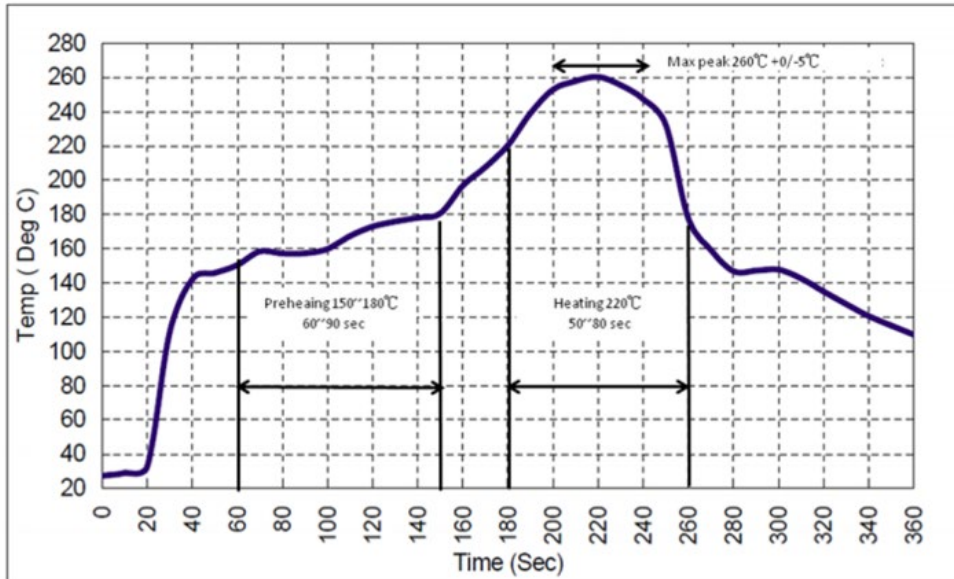

## Recommended Reflow Profile

1. Preheating shall be fixed at 150~180°C for 60~90 seconds.
2. Ascending time to preheating temperature 150°C shall be 30 seconds min.
3. Heating shall be fixed at 220°C for 50~80 seconds and at 260°C +0/-5°C peak (10 seconds).
4. Time: 5 times maximum.



## Looking for pricing, stock, or lifecycle information?

Click below to explore more details on WIN SOURCE:

-  [View RO3118D on WIN SOURCE](#)
-  [RF Monolithics, Inc Information](#)

## Optimize Your Supply Chain with WIN SOURCE Solutions

-  Global Sourcing Solution
-  Obsolete Management
-  Cost Control Management
-  Shortage Management
-  Alternative Solution
-  Excess Inventory Management