



THE DATASHEET OF RO3103D



- Ideal for 418.0 MHz Remote Control and Security Transmitters
- Very Low Series Resistance
- Quartz Stability
- Surface Mount Ceramic Case
- Complies with Directive 2002/95/EC (RoHs)
- Tape and Reel Standard per ANSI/EIA-481
- Moisture Sensitivity Level: 1
- AEC-Q200 Qualified

The RO3103D is a true one-port, surface-acoustic-wave (SAW) resonator in a surface-mount, ceramic case. It provides reliable, fundamental-mode, quartz frequency stabilization of fixed-frequency transmitters operating at 418.0 MHz. This SAW is designed specifically for transmitters used in remote control and wireless security applications.

Absolute Maximum Ratings

Rating	Value	Units
CW RF Power Dissipation (See Test Circuit)	0	dBm
DC Voltage Between Terminals (Observe ESD Precautions)	12	VDC
Case Temperature	-40 to +85	°C
Soldering Temperature (10 seconds / 5 cycles maximum)	260	°C

RO3103D

**418.00 MHz
SAW
Resonator**

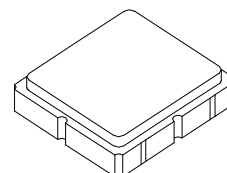

**SM3838-6 Case
3.8 x 3.8 mm**

Electrical Characteristics

Characteristic		Sym	Notes	Minimum	Typical	Maximum	Units
Frequency, +25 °C	Nominal Frequency	f_C		417.925		418.075	MHz
	Tolerance from 418.0 MHz	Δf_C				± 75	kHz
Insertion Loss		IL			1.4	2.0	dB
Quality Factor	Unloaded Q	Q_U			10400		
	50 Ω Loaded Q	Q_L			1400		
Temperature Stability	Turnover Temperature	T_O		10	25	40	°C
	Turnover Frequency	f_O			f_C		
	Frequency Temperature Coefficient	FTC			0.032		ppm/°C ²
Frequency Aging	Absolute Value during the First Year	$ f_A $			10		ppm/yr
DC Insulation Resistance between Any Two Terminals				1.0			M Ω
RF Equivalent RLC Model	Motional Resistance	R_M			16.7		Ω
	Motional Inductance	L_M			64.8		μ H
	Motional Capacitance	C_M			2.2		fF
	Transducer Static Capacitance	C_O			2.4		pF
Test Fixture Shunt Inductance		L_{TEST}			60.1		nH
Lid Symbolization: Y = Year, WW = Week, S = Shift)				717, <u>YWWS</u>			
Standard Reel Quantity	Reel Size 7 Inch			500 Pieces/Reel			
	Reel Size 13 Inch			3000 Pieces/Reel			



CAUTION: Electrostatic Sensitive Device. Observe precautions for handling.

NOTES:

1. The design, manufacturing process, and specifications of this device are subject to change.
2. US or International patents may apply.
3. RoHS compliant from the first date of manufacture.

Electrical Connections

The SAW resonator is bidirectional and may be installed with either orientation. The two terminals are interchangeable and unnumbered. The callout NC indicates no internal connection. The NC pads assist with mechanical positioning and stability. External grounding of the NC pads is recommended to help reduce parasitic capacitance in the circuit.

Pin	Connection
1	NC
2	Terminal
3	NC
4	NC
5	NC
6	Terminal
7	NC
8	NC

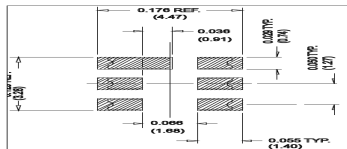
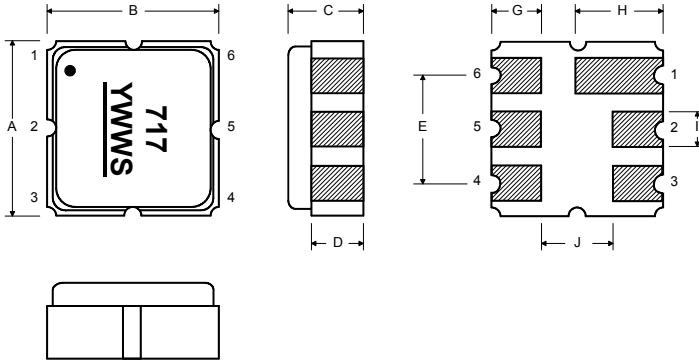

Case Dimensions

Dimension	mm			Inches		
	Min	Nom	Max	Min	Nom	Max
A	3.60	3.80	4.00	0.142	0.150	0.157
B	3.60	3.80	4.00	0.142	0.150	0.157
C	1.10	1.30	1.50	0.043	0.050	0.060
D	0.95	1.10	1.25	0.037	0.043	0.049
E	2.39	2.54	2.69	0.094	0.100	0.106
G	0.90	1.00	1.10	0.035	0.040	0.043
H	1.90	2.00	2.10	0.748	0.079	0.083
I	0.50	0.60	0.70	0.020	0.024	0.028
J	1.70	1.80	1.90	0.067	0.071	0.075

Equivalent RLC Model

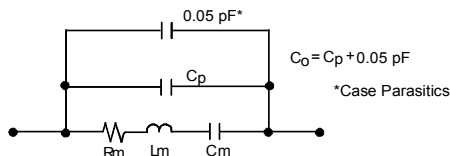

Parameter Test Circuit

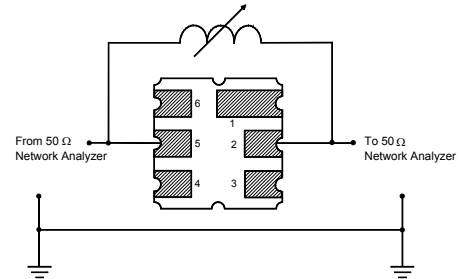

Power Test Circuit

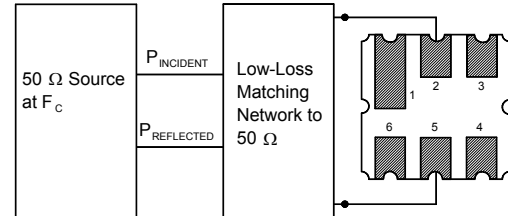

Example Application Circuits

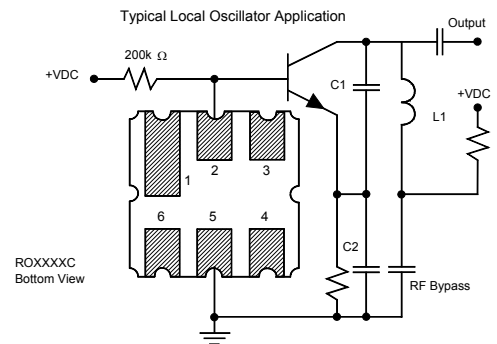
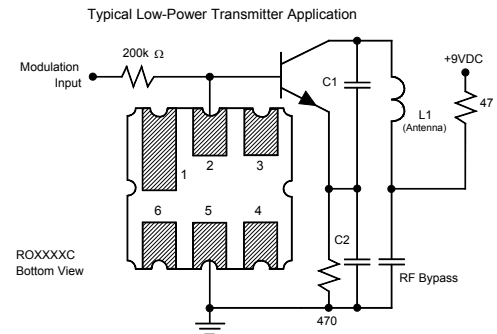

Temperature Characteristics

The curve shown on the right accounts for resonator contribution only and does not include LC component temperature contributions.

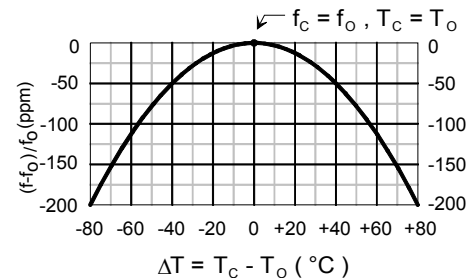

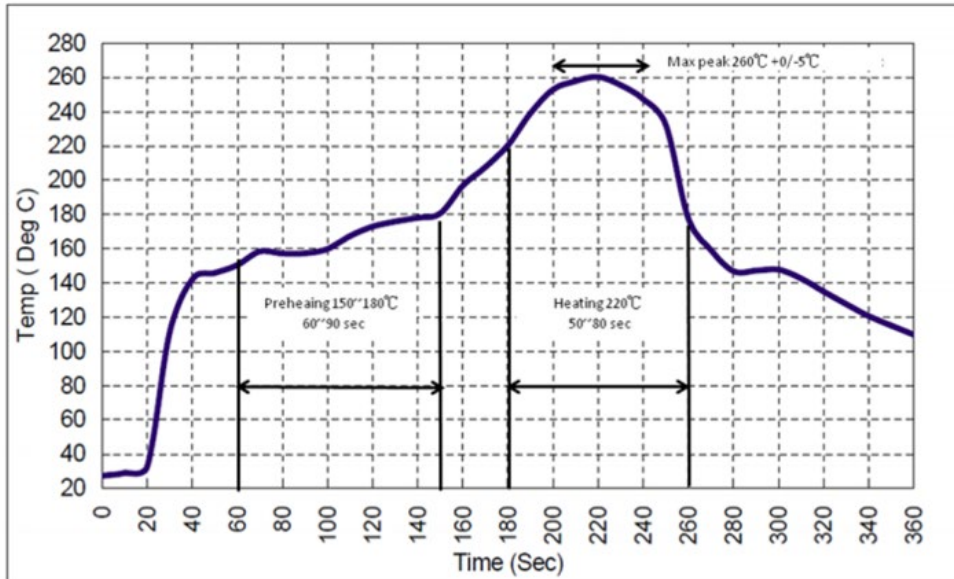

Recommended Reflow Profile

1. Preheating shall be fixed at 150~180°C for 60~90 seconds.
2. Ascending time to preheating temperature 150°C shall be 30 seconds min.
3. Heating shall be fixed at 220°C for 50~80 seconds and at 260°C +0/-5°C peak (10 seconds).
4. Time: 5 times maximum.



Looking for pricing, stock, or lifecycle information?

Click below to explore more details on WIN SOURCE:

-  [View RO3103D on WIN SOURCE](#)
-  [RF Monolithics, Inc Information](#)

Optimize Your Supply Chain with WIN SOURCE Solutions

-  Global Sourcing Solution
-  Obsolete Management
-  Cost Control Management
-  Shortage Management
-  Alternative Solution
-  Excess Inventory Management