



**THE DATASHEET OF  
XZMECBDDG45SHTA**



### Features

- Ideal for indication light on hand held products
- Long life and robust package
- Package: 2,000pcs / reel
- MSL (Moisture Sensitivity Level): 3
- Halogen-free
- RoHS compliant

### Applications

- Backlighting for tell-tale indicators
- Dashboard lighting
- Interior lighting (footwell, dome light, accent lighting, etc.)
- Exterior lighting (turn signals, side markers, CHMSL, etc.)
- Signs and signals
- Various applications requiring high temperature rating



**ATTENTION**  
OBSERVE PRECAUTIONS  
FOR HANDLING  
ELECTROSTATIC  
DISCHARGE  
SENSITIVE  
DEVICES

### Package Schematics

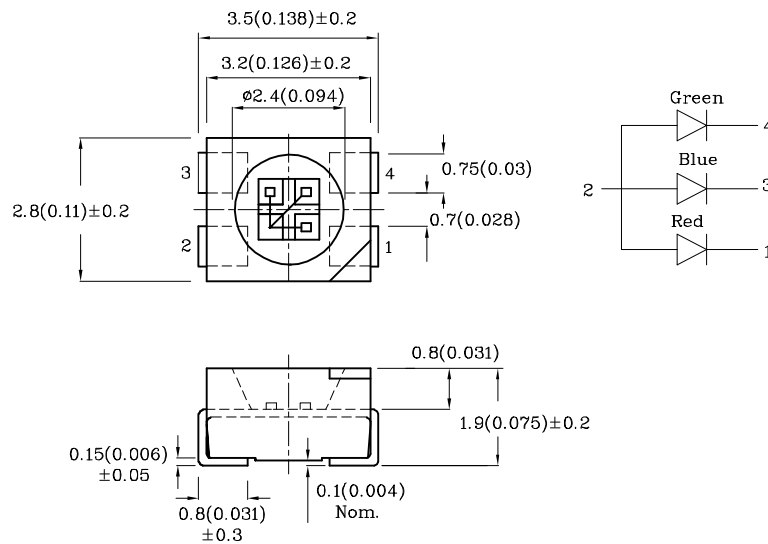

#### Notes:

1. All dimensions are in millimeters (inches).
2. Tolerance is ±0.25(0.01") unless otherwise noted.
3. Specifications are subject to change without notice.

## Handling Precautions

Compare to epoxy encapsulant that is hard and brittle, silicone is softer and flexible. Although its characteristic significantly reduces thermal stress, it is more susceptible to damage by external mechanical force.

As a result, special handling precautions need to be observed during assembly using silicone encapsulated LED products. Failure to comply might lead to damage and premature failure of the LED.

1. Handle the component along the side surfaces by using forceps or appropriate tools.

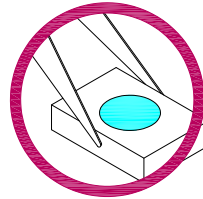

2. Do not directly touch or handle the silicone lens surface. It may damage the internal circuitry.

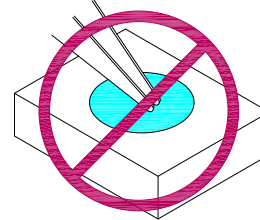
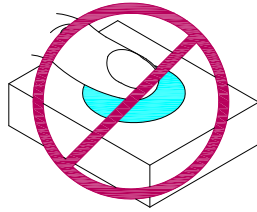

3. Do not stack together assembled PCBs containing exposed LEDs. Impact may scratch the silicone lens or damage the internal circuitry.

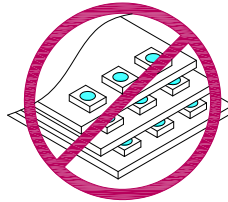

- 4.1. The inner diameter of the SMD pickup nozzle should not exceed the size of the LED to prevent air leaks.
- 4.2. A pliable material is suggested for the nozzle tip to avoid scratching or damaging the LED surface during pickup.
- 4.3. The dimensions of the component must be accurately programmed in the pick-and-place machine to insure precise pickup and avoid damage during production.

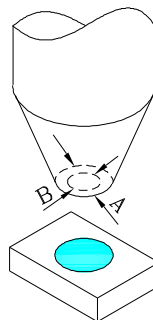

5. As silicone encapsulation is permeable to gases, some corrosive substances such as H<sub>2</sub>S might corrode silver plating of lead-frame. Special care should be taken if an LED with silicone encapsulation is to be used near such substances.

Part Number	Emitting Color (Material)	Lens-color	Luminous Intensity CIE127-2007* ( $I_F=20mA$ ) mcd			Viewing Angle [1]
			Code.	min.	max.	
XZMECBDDG45SHTA	Red (AlGaInP)	Water Clear	N*	120*	200*	20 1/2
			P*	200*	300*	
			Q*	300*	400*	
	Blue (InGaN)		H*	55*	80*	
			M*	80*	120*	
			N*	120*	200*	
	Green (InGaN)		T*	700*	1000*	
			U*	1000*	1300*	
			V*	1300*	1600*	

Notes:

- 01/2 is the angle from optical centerline where the luminous intensity is 1/2 of the optical peak value.
- \* Luminous intensity value and wavelength are in accordance with CIE127-2007 standards.
- Listed bin codes represent the possible range for this LED. Actual bin codes received will be based upon production yields.

**Absolute Maximum Ratings at  $T_a=25^\circ C$**

Parameter	Symbol	Value			Unit
		Red	Blue	Green	
Power dissipation	$P_D$	75	80	82	mW
Reverse Voltage	$V_R$	5	5	5	V
Junction temperature	$T_J$	115	115	115	$^\circ C$
Operating Temperature	Top	-40 To +100			$^\circ C$
Storage Temperature	$T_{stg}$	-40 To +110			$^\circ C$
DC Forward Current	$I_F$	30	20	20	mA
Peak Forward Current	$I_{FP}^{[1]}$	195	150	150	mA
Electrostatic Discharge Threshold (HBM)		3000	250	450	V
Thermal Resistance (Junction/ambient)	$R_{th(j-a)}^{[2]}$	290	430	420	$^\circ C/W$
Thermal Resistance (Junction / Solder point)	$R_{th(j-s)}^{[2]}$	120	280	250	$^\circ C/W$

Notes:

- 1/10 Duty Cycle, 0.1ms Pulse Width.
- $R_{th(j-a)}$  Results from mounting on PC board FR4 (pad size  $\geq 16 \text{ mm}^2$  per pad).
- A Relative Humidity between 40% and 60% is recommended in ESD-protected work areas to reduce static build up during assembly process (Reference JEDEC/JESD625-A and JEDEC/J-STD-033).

Electrical / Optical Characteristics at Ta=25°C

Parameter	Symbol	Chip	Value				Unit
			Code.	Min.	Typ.	Max.	
Wavelength at Peak Emission CIE127-2007* I <sub>F</sub> = 20mA	λ <sub>peak</sub>	Red Blue Green	-	-	630* 460* 515*	-	nm
Dominant Wavelength CIE127-2007* I <sub>F</sub> = 20mA	λ <sub>dom</sub> [1]	Red	-	610*	-	635*	nm
		Blue	1A*	460*	-	463*	
			1B*	463*	-	466*	
			2A*	466*	-	469*	
			2B*	469*	-	471*	
		Green	3A*	471*	-	473*	
			1*	515*	-	520*	
			2*	520*	-	525*	
			3*	525*	-	530*	
		4*	530*	-	535*		
Spectral bandwidth at 50%Φ <sub>REL MAX</sub> I <sub>F</sub> = 20mA	Δλ	Red Blue Green	-	-	20 25 35	-	nm
Forward Voltage I <sub>F</sub> = 20mA	V <sub>F</sub> [2]	Red Blue Green	-	-	2.0 3.3 3.3	2.5 4.0 4.1	V
Reverse Current (V <sub>R</sub> = 5V)	I <sub>R</sub>	Red Blue Green	-	-	-	10 50 50	μA
Temperature coefficient of λ <sub>peak</sub> I <sub>F</sub> = 20mA, -10°C ≤ T ≤ 100°C	TC λ <sub>peak</sub>	Red Blue Green	-	-	0.13 0.04 0.05	-	nm/°C
Temperature coefficient of λ <sub>dom</sub> I <sub>F</sub> = 20mA, -10°C ≤ T ≤ 100°C	TC λ <sub>dom</sub>	Red Blue Green	-	-	0.06 0.03 0.03	-	nm/°C
Temperature coefficient of V <sub>F</sub> I <sub>F</sub> = 20mA, -10°C ≤ T ≤ 100°C	TC <sub>V</sub>	Red Blue Green	-	-	-1.9 -2.9 -2.9	-	mV/°C

Notes:

- The dominant Wavelength (λ<sub>d</sub>) above is the setup value of the sorting machine. (Tolerance λ<sub>d</sub> : ±1nm.)
- Forward Voltage: +/-0.1V.
- \* wavelength value is in accordance with CIE127-2007 standards.
- Listed bin codes represent the possible range for this LED. Actual bin codes received will be based upon production yields.

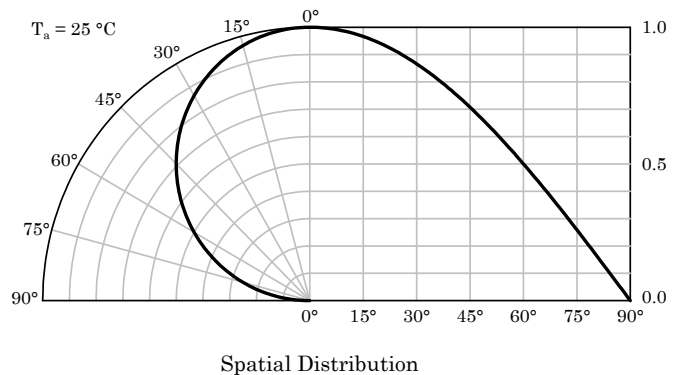
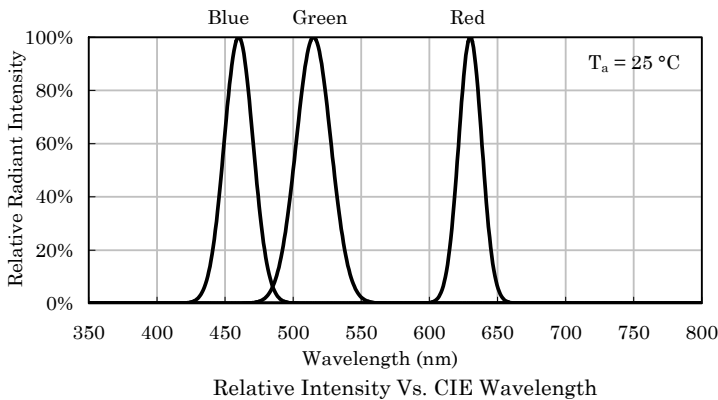

❖ Red

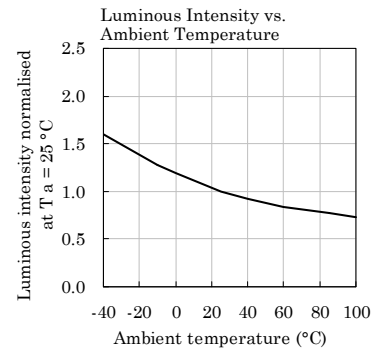
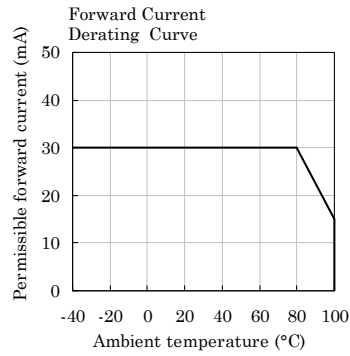
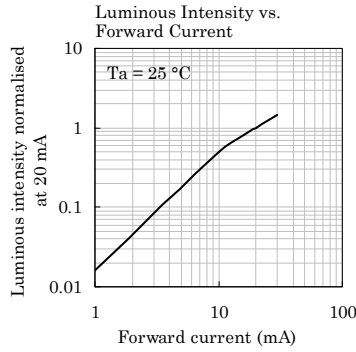
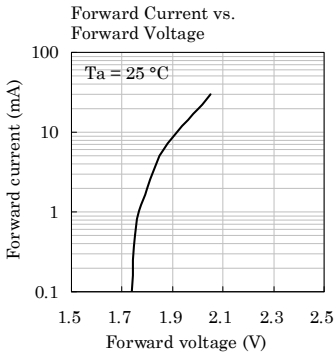

❖ Blue

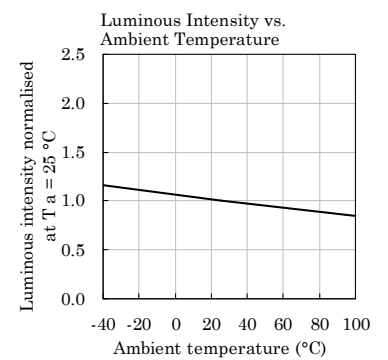
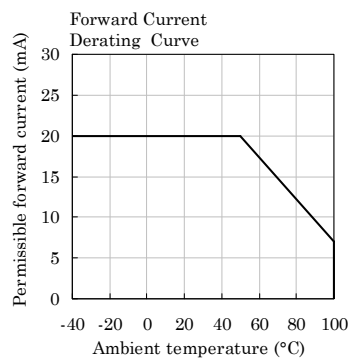
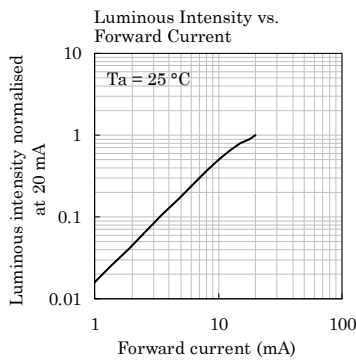
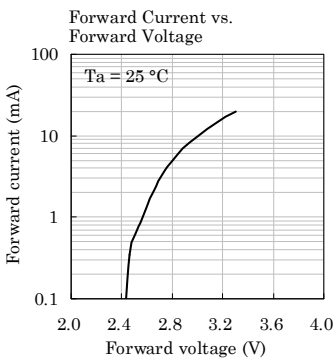

❖ Green

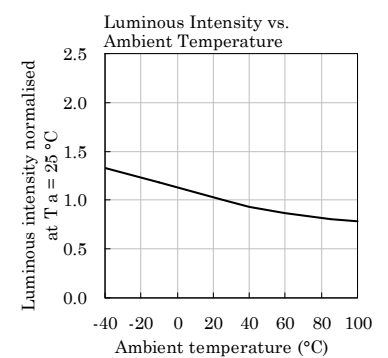
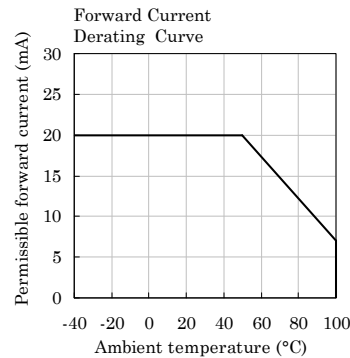
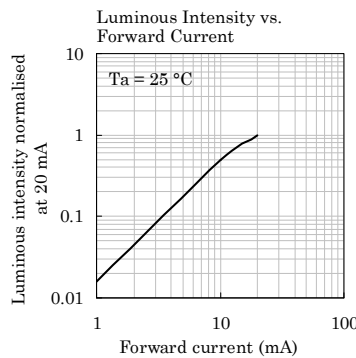
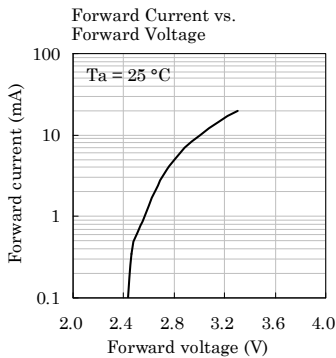

Reflow soldering is recommended and the soldering profile is shown below.  
Other soldering methods are not recommended as they might cause damage to the product.

Reflow Soldering Profile for SMD Products (Pb-Free Components)

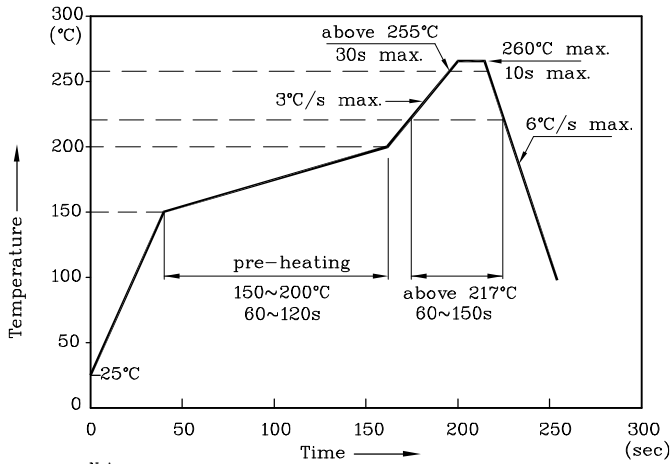

Notes:

1. All temperatures refer to the center of the package, measured on the package body surface facing up during reflow.
2. Do not apply any stress to the LED during high temperature conditions.
3. Maximum number of soldering passes: 2

❖ The device has a single mounting surface. The device must be mounted according to the specifications.

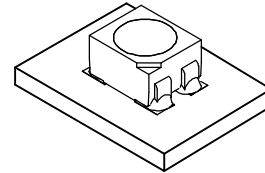

❖ Recommended Soldering Pattern (Units : mm; Tolerance: ± 0.1)

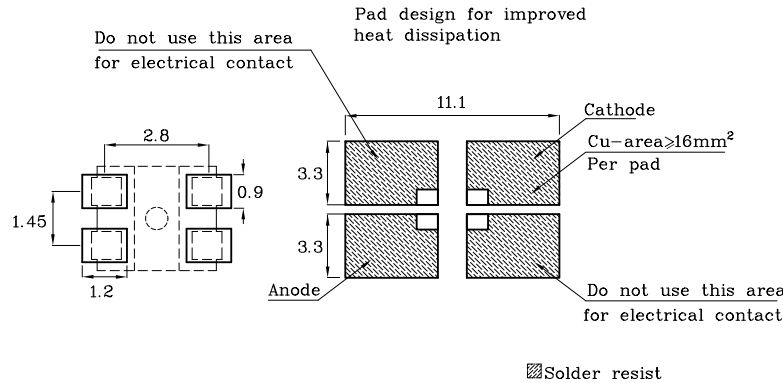

❖ Tape Specification (Units : mm)

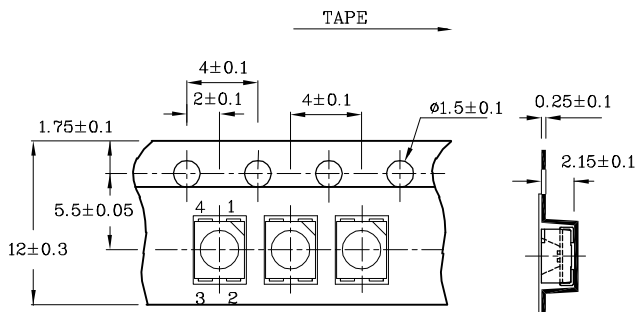

❖ Reel Dimension (Units : mm)

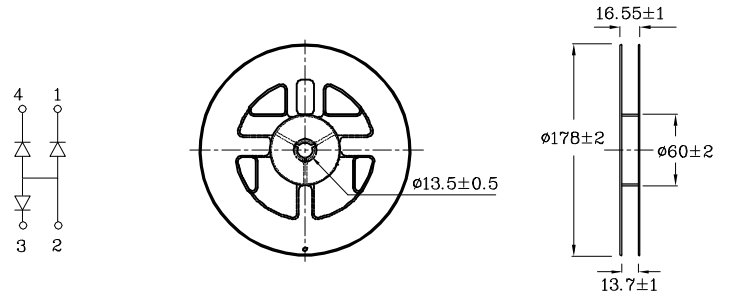

**PACKING & LABEL SPECIFICATIONS**

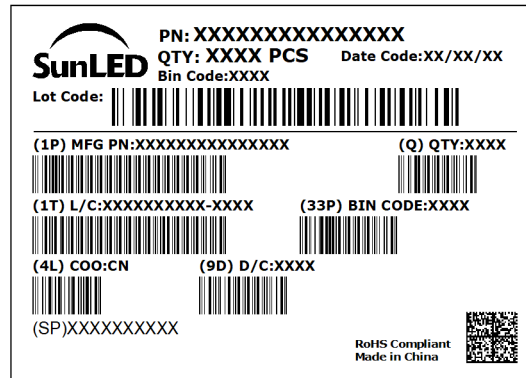
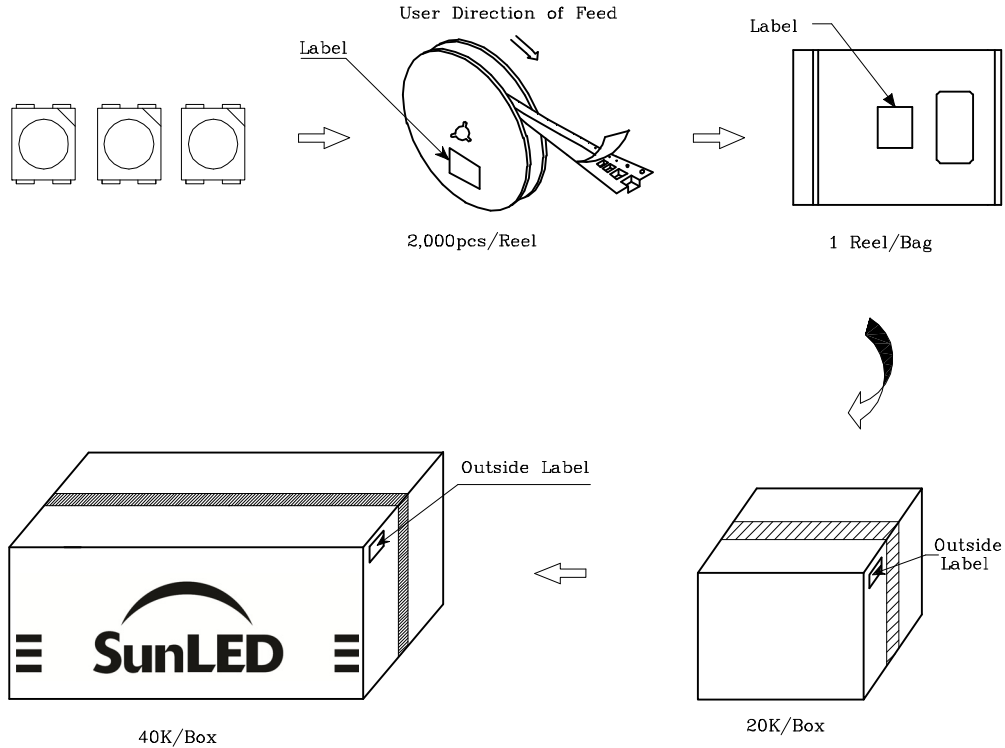

**TERMS OF USE**

1. Data presented in this document reflect statistical figures and should be treated as technical reference only.
2. Contents within this document are subject to improvement and enhancement changes without notice.
3. The product(s) in this document are designed to be operated within the electrical and environmental specifications indicated on the datasheet. User accepts full risk and responsibility when operating the product(s) beyond their intended specifications.
4. The product(s) described in this document are intended for electronic applications in which a person's life is not reliant upon the LED. Please consult with a SunLED representative for special applications where the LED may have a direct impact on a person's life.
5. The performance of the product(s) should be evaluated and verified by the customer to ensure it can meet the customer's application requirements.
6. The contents within this document may not be altered without prior consent by SunLED.
7. Additional technical notes are available at <https://www.SunLEDusa.com/TechnicalNotes.asp>

### Reliability Test Items And Conditions

The reliability of products shall be satisfied with items listed below

**Lot Tolerance Percent Defective (LTPD) : 10%**

No.	Test Item	Standards	Test Condition	Test Times / Cycles	Number of Damaged
1	Continuous operating test	-	$T_a = 25^{\circ}\text{C}$ , $I_F =$ maximum rated current *	1,000 h	0 / 22
2	High Temp. operating test	EIAJ ED-4701/100(101)	$T_a = 100^{\circ}\text{C}$ , $I_F =$ maximum rated current *	1,000 h	0 / 22
3	Low Temp. operating test	-	$T_a = -40^{\circ}\text{C}$ , $I_F =$ maximum rated current *	1,000 h	0 / 22
4	High temp. storage test	EIAJ ED-4701/100(201)	$T_a =$ maximum rated storage temperature	1,000 h	0 / 22
5	Low temp. storage test	EIAJ ED-4701/100(202)	$T_a = -40^{\circ}\text{C}$	1,000 h	0 / 22
6	High temp. & humidity storage test	-	$T_a = 60^{\circ}\text{C}$ , RH = 90%	500 h	0 / 22
7	High temp. & humidity operating test	-	$T_a = 60^{\circ}\text{C}$ , RH = 90% $I_F =$ maximum rated current *	500 h	0 / 22
8	Soldering reliability test	EIAJ ED-4701/100(301)	Moisture soak: $30^{\circ}\text{C}$ , 70% RH, 72h Preheat: $150\sim 180^{\circ}\text{C}$ (120s max.) Soldering temp: $260^{\circ}\text{C}$ (10s)	2 times	0 / 18
9	Thermal shock operating test	-	$T_a = -40^{\circ}\text{C}$ (15min) ~ $100^{\circ}\text{C}$ (15min) $I_F =$ derated current at $100^{\circ}\text{C}$	1,000 cycles	0 / 22
10	Thermal shock test	-	$T_a = -40^{\circ}\text{C}$ (15min) ~ maximum rated storage temperature(15min)	1,000 cycles	0 / 22
11	Electric Static Discharge (ESD)	EIAJ ED-4701/100(304)	$C = 100\text{pF}$ , $R_2 = 1.5\text{K}\Omega$ $V = 3000\text{V}$ (Red) $V = 250\text{V}$ (Blue) $V = 450\text{V}$ (Green)	Once each Polarity	0 / 22
12	Vibration test	-	$a = 196\text{m/s}^2$ , $f = 100\sim 2\text{KHz}$ , $t = 48\text{min}$ for all xyz axes	4 times	0 / 22



\* : Refer to forward current vs. derating curve diagram

### Criteria for Judging Damage

Items	Symbols	Conditions	Failure Criteria
luminous Intensity	lv	$I_F = 20\text{mA}$	Testing Min. Value < Spec. Min. Value x 0.5
Forward Voltage	VF	$I_F = 20\text{mA}$	Testing Max. Value $\geq$ Spec. Max. Value x 1.2
Reverse Current	IR	VR = Maximum Rated Reverse Voltage	Testing Max. Value $\geq$ Spec. Max. Value x 2.5
High temp. storage test	-	-	Occurrence of notable decoloration, deformation and cracking

## Looking for pricing, stock, or lifecycle information?

Click below to explore more details on WIN SOURCE:

-  View [XZMECBDDG45SHTA](#) on WIN SOURCE
-  [SunLED](#) Information

## Optimize Your Supply Chain with WIN SOURCE Solutions

-  Global Sourcing Solution
-  Obsolete Management
-  Cost Control Management
-  Shortage Management
-  Alternative Solution
-  Excess Inventory Management