

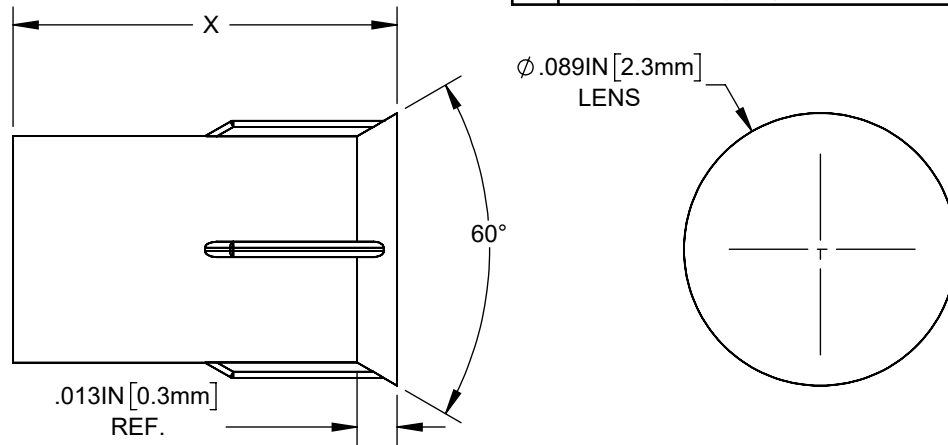

THE DATASHEET OF PLPC2-9MM

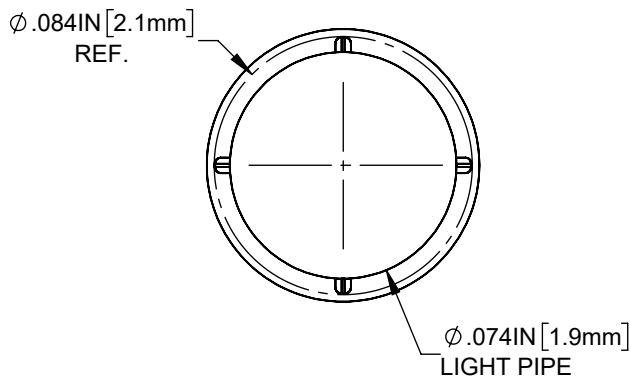

REVISIONS			
REV.	DESCRIPTION	DATE	APPROVED
B	Engineering Release	07/15/15	J.C.
C	Added Color Options, Sheet #2	01/25/16	J.C.
D	Revised Color Table, Sheet #2	7/02/2018	G.O.
E	Revised Mounting Hole Spec per ECO-1209	7/10/2023	A.V.
F	Revise Typo in Body Length Chart per ECO-1229	10/30/2023	A.V.



BODY LENGTHS FOR CLEAR LIGHT PIPES

PART NO.	X = BODY LENGTH
PLPC2-100	0.100 (2.5mm)
PLPC2-125	0.125 (3.2mm)
PLPC2-188	0.188 (4.8mm)
PLPC2-250	0.250 (6.4mm)
PLPC2-313	0.313 (7.9mm)
PLPC2-375	0.375 (9.5mm)
PLPC2-500	0.500 (12.7mm)
PLPC2-3MM	3mm (0.118")
PLPC2-4MM	4mm (0.157")
PLPC2-5MM	5mm (0.197")
PLPC2-6MM	6mm (0.236")
PLPC2-7MM	7mm (0.276")
PLPC2-8MM	8mm (0.315")
PLPC2-9MM	9mm (0.354")
PLPC2-10MM	10mm (0.394")

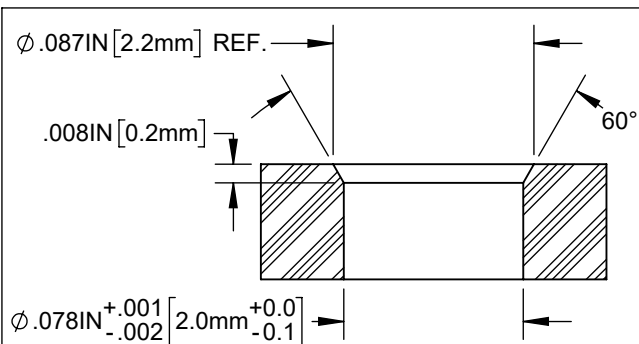

RECOMMENDED MOUNTING HOLE:
 STEP 1: DRILL Ø 0.078" (2mm) THROUGH HOLE
 STEP 2: USE 60° COUNTERSINK DRILL BIT TO DRILL DOWN 0.008" (0.2mm)

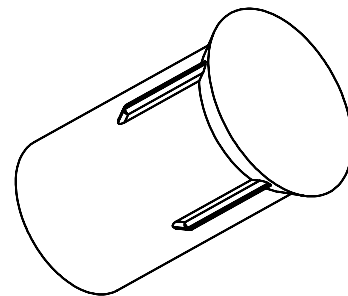

CUSTOMER USE DRAWING

- NOTES:
 2. MATERIAL: POLYCARBONATE, UL94V-0, CLEAR.
 1. GENERAL SPECIFICATIONS: BIVAR MOLDED COMPONENT SPECIFICATIONS: BV00-E101 and BSCM-1001

STANDARD TOLERANCE (UNLESS OTHERWISE SPECIFIED)		 4 THOMAS, IRVINE, CA. 92618 TEL: (949) 951-8808 FAX: (949) 951-3974	
DECIMALS	ANGULAR		
.X ± .1	X° ± 1°	TITLE: PRESS FIT, PANEL MOUNT LIGHT PIPE, FLUSH, 2mm	
.XX ± .01			
.XXX ± .005			
DESIGNED: A. WRIGHT	DATE: 4/24/15	DRAWING NO.: PLPC2-XXX	REVISION: F
REVISED: M. PAGDONSOLAN	DATE: 10/30/23	SHEET SIZE: A	CAGE CODE: 32559
CHECKED: A. VALDEZ	DATE: 10/30/23	SCALE: 24:1	SHEET # 1 OF 2

CAD GENERATED DOCUMENT, DO NOT MEASURE DRAWING

OTHER AVAILABLE COLORS
 *SEE TABLE FOR ORDERING INFORMATION

REVISIONS			
REV.	DESCRIPTION	DATE	APPROVED
-	SEE SHEET1	-	-

AVAILABLE COLOR OPTIONS

PLPC2 -

RIGID LIGHT PIPE SERIES LENGTH

PART NUMBER	BODY LENGTH	COLOR	ORDER CODE
PLPC2-100	0.100" (2.5mm)	TINTED BLUE	BE
PLPC2-125	0.125" (3.2mm)	TINTED GREEN	GN
PLP2-2.5mm	2.5mm (0.100")	TINTED RED	RD
PLPC2-3mm	3mm (0.118")	TINTED YELLOW	YW

PLPC2 -

RIGID LIGHT PIPE SERIES LENGTH

PART NUMBER	BODY LENGTH	COLOR	ORDER CODE
PLPC2-100	0.100" (2.5mm)	DIFFUSED	D
PLPC2-125	0.125" (3.2mm)	SMOKED	S
PLP2-2.5mm	2.5mm (0.100")		
PLPC2-3mm	3mm (0.118")		

CUSTOMER USE DRAWING

STANDARD TOLERANCE (UNLESS OTHERWISE SPECIFIED)		 BIVAR [®] 4 THOMAS, IRVINE, CA. 92618 TEL: (949) 951-8808 FAX: (949) 951-3974	
DECIMALS	ANGULAR		
.X ± .1	X° ± 1°		
.XX ± .01			
.XXX ± .005		TITLE: PRESSFIT, PANEL MOUNT LIGHT PIPE, FLUSH, 2mm	
DESIGNED: A. WRIGHT	DATE: 4/24/15	DRAWING NO: PLPC2-XXX	REVISION: F
REVISED: M. PAGDONSOLAN	DATE: 7/10/23	SHEET SIZE A	CAGE CODE: 32559
CHECKED: A. VALDEZ	DATE: 7/10/23	SCALE: 24:1	SHEET # 2 OF 2
CAD GENERATED DOCUMENT, DO NOT MEASURE DRAWING			

Looking for pricing, stock, or lifecycle information?

Click below to explore more details on WIN SOURCE:

 [View PLPC2-9MM on WIN SOURCE](#)

 [Bivar Inc. Information](#)

Optimize Your Supply Chain with WIN SOURCE Solutions

-  Global Sourcing Solution
-  Obsolete Management
-  Cost Control Management
-  Shortage Management
-  Alternative Solution
-  Excess Inventory Management