



**THE DATASHEET OF
DIO5644WL12**



DIO5644

Dual 1.5 A Current Source Camera Flash LED Driver

Features

- Dual independent 1.5 A LED current source programmability
- Efficiency higher than 87% in torch mode at 100 mA and flash mode at 1 A to 1.5 A
- Optimized flash LED current during low battery conditions (IVFM)
- Grounded cathode LED operation for improved thermal management
- Hardware strobe enable (STROBE)
- Synchronization input for RF power amplifier pulse events (TX)
- Hardware torch enable (TORCH/TEMP)
- Remote NTC monitoring (TORCH/TEMP)
- 400 kHz I²C-compatible interface
7-bit address: 0x63

Applications

- Camera phone white LED flash

Descriptions

The DIO5644 is a dual LED flash driver that has a small solution size and provides a high level of adjustability. It operates using a 2 MHz or 4 MHz fixed-frequency synchronous boost converter to power the dual 128-level current sources, which can be adjusted to control the current ratios between LED1 and LED2. An adaptive regulation method ensures that the current sources remain in regulation and maximizes efficiency.

The features of the DIO5644 can be controlled through an I²C-compatible interface. The features include hardware flash and hardware torch pins (STROBE and TORCH/TEMP), a TX interrupt, and an NTC thermistor monitor. The device offers independently programmable currents in each output leg, making it possible to drive the LEDs either in flash or torch mode.

Thanks to its 2 MHz or 4 MHz switching frequency options, overvoltage protection (OVP), and adjustable current limit, the DIO5644 can employ small, low-profile inductors and 10 μ F ceramic capacitors. Additionally, the device is capable of operating within an ambient temperature range of -40°C to 85°C.

Ordering Information

Part Number	Top Marking	RoHS	T _A	Package	
DIO5644WL12	5644	Green	-40 to +85°C	WLCSP-12	Tape & Reel, 3000

Pin Assignment

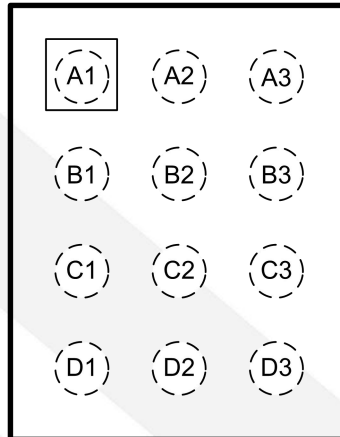

Figure 1. WLCSP-12 (Top view)

Pin Descriptions

Pin		Description
Number	Name	
A1	GND	Ground.
A2	IN	Input supply. Connect IN to the input supply and bypass to GND with a 10 μ F or larger ceramic capacitor.
A3	SDA	Bidirectional serial data input/output in the I ² C mode.
B1	SW	Switching pin of the boost converter.
B2	STROBE	Active high hardware flash enable. Drive STROBE high to turn on flash pulse. Internal pull-down resistor of 400 k Ω between STROBE and GND.
B3	SCL	Serial clock input.
C1	OUT	Output pin of the boost converter. Connect a 10 μ F ceramic capacitor between this terminal and GND.
C2	HWEN	Active high hardware enable pin. High = Standby, Low = Shutdown/Reset. Internal pull-down resistor of 400 k Ω between HWEN and GND.
C3	TORCH/TEMP	Active high TORCH enable pin. Torch terminal input or threshold detector for NTC temperature sensing and current scale back.
D1	LED2	High-side current source output for flash LED.
D2	TX	Active high power amplifier synchronization input pin. Internal pull-down resistor of 400 k Ω between TX and GND.
D3	LED1	High-side current source output for flash LED.



DIO5644

Absolute Maximum Ratings

Stresses beyond those listed under the Absolute Maximum Rating table may cause permanent damage to the device. These are stress ratings only and functional operation of the device at these or any other condition beyond those indicated in the operational sections of the specifications is not implied. Exposure to absolute maximum rating conditions for extended periods may affect device reliability.

Symbol	Parameter	Rating	Unit
	IN, SW, OUT, LED1, LED2	-0.3 to 6.0	V
	SDA, SCL, TX, TORCH/TEMP, HWEN, STROBE	-0.3 to $V_{IN}+0.3$ (< 6 V)	V
P_D	Continuous power dissipation	Internally limited	
T_{J-MAX}	Junction temperature	150	°C
T_{STG}	Storage temperature range	-65 to 150	°C
ESD	Electrostatic discharge	HBM	4500 V

Recommend Operating Conditions

The Recommended Operating Conditions table defines the conditions for actual device operation. Recommended operating conditions are specified to ensure optimal performance to the datasheet specifications. DIOO does not recommend exceeding them or designing to absolute maximum ratings.

Symbol	Parameter	Rating	Unit
V_{IN}	Supply voltage	2.7 to 5.5	V
T_J	Junction temperature	-40 to 125	°C
T_A	Ambient temperature	-40 to 85	

Thermal Information

Symbol	Parameter	Rating	Unit
$R_{\theta JA}$	Junction-to-ambient thermal resistance	90	°C/W
$R_{\theta JC(top)}$	Junction-to-case (top) thermal resistance	0.5	



DIO5644

Dual 1.5 A Current Source Camera Flash LED Driver

Electrical Characteristics

Typical value: $V_{CC} = 3.6\text{ V}$, $HWEN = V_{IN}$, $T_A = 25^\circ\text{C}$, unless otherwise specified.

Symbol	Parameter	Conditions	Min	Typ	Max	Unit
Current source specifications						
$I_{LED1/2}$	Current source accuracy	$V_{OUT} = 4\text{ V}$, flash code = 0x7F = 1.5 A flash	-7%	1.5	7%	A
		$V_{OUT} = 4\text{ V}$, torch code = 0x3F = 92.5 mA torch	-10%	92.5	10%	mA
V_{HR}	LED1 and LED2 current source regulation voltage	$I_{LED1/2} = 750\text{ mA}$ flash		290		mV
		$I_{LED1/2} = 179\text{ mA}$ torch		158		
V_{OVP}		ON threshold	4.86	5	5.1	V
		OFF threshold	4.75	4.88	4.99	
Step-up DC/DC converter specifications						
R_{PMOS}	PMOS switch on-resistance			86		m Ω
R_{NMOS}	NMOS switch on-resistance			65		
I_{CL}	Switch current limit	Reg 0x07, bit[0] = 0	-12%	2.7	12%	A
		Reg 0x07, bit[0] = 1	-12%	3.8	12%	
UVLO	Under voltage lockout threshold	Falling V_{IN}			2.65	V
V_{TRIP}	NTC comparator trip threshold	Reg 0x09, bits[3:1] = '100'	-5%	0.6	5%	V
I_{NTC}	NTC current		-6%	50	6%	μA
V_{IVFM}	Input voltage flash monitor trip threshold	Reg 0x02, bits[5:3] = '000'	-3%	2.9	3%	V
I_Q	Quiescent supply current	Device not switching pass mode		0.3	0.75	mA
I_{SD}	Shutdown supply current	Device disabled, $HWEN = 0\text{ V}$, $2.7\text{ V} \leq V_{IN} \leq 5.5\text{ V}$		0.1	4	μA
I_{SB}	Standby supply current	Device disabled, $HWEN = 1.8\text{ V}$, $2.7\text{ V} \leq V_{IN} \leq 5.5\text{ V}$		2.5	10	μA
HWEN, TORCH/TEMP, STROBE, TX voltage specifications						
V_{IL}	Input logic low	$2.7\text{ V} \leq V_{IN} \leq 5.5\text{ V}$	0		0.4	V
V_{IH}	Input logic high		1.5		V_{IN}	
I²C-compatible interface specifications (SCL, SDA)						
V_{IL}	Input logic low	$2.7\text{ V} \leq V_{IN} \leq 5.5\text{ V}$	0		0.4	V
V_{IH}	Input logic high		1.5		V_{IN}	
V_{OL}	Output logic low	$I_{LOAD} = 3\text{ mA}$			400	mV
Switching characteristics						
f_{SW}	Switching frequency	$2.7\text{ V} \leq V_{IN} \leq 5.5\text{ V}$	-6%	4	6%	MHz

Note: Specifications subject to change without notice.



DIO5644

Detailed Description

Overview

The DIO5644 is a flash LED driver that has the ability to deliver high current pulses to two separate high power LEDs: up to 1.5 A for LED1 and LED2 simultaneously. This driver is packaged in a small WLCSP size and consists of a synchronous boost converter with a high switching frequency and two independent current sources. The boost converter includes two low $R_{DS(ON)}$ power MOSFETs and can operate at a switching frequency of either 2 MHz or 4 MHz, which helps to minimize the size of external inductors and capacitors.

Unlike a traditional DC-DC boost converter, the DIO5644 dynamically adjusts the output voltage based on the forward voltage and current of the flash LEDs. It only boosts the output to a voltage that is sufficient to drive the LEDs at the programmed output current. The unique control scheme used in the current sources maintains accurate current regulation while minimizing the output voltage, which helps to increase the overall conversion efficiency.

The control interface of the DIO5644 is designed to be flexible and compatible with various system controls. It can be programmed and controlled through an I²C-compatible interface, and also includes three logic inputs that can provide a hardware flash enable (STROBE), hardware torch enable (TORCH), and a flash interrupt (TX) which can be used to reduce the flash current during power amplifier pulse events to lower the battery load current.

The I²C control features of the DIO5644 include independent on/off and current control for the two current sources in Flash/Torch/IR modes, on/off ramp timing and current shape control, three input low voltage protection modes, flash safety time-out protection, boost converter current limit and switching frequency options, and various fault events read back.

Additionally, the DIO5644 includes various protection features such as LED open and short protections, thermal regulation to prevent the IC temperature from becoming too high, and thermal shutdown protection.



Functional Block Diagram

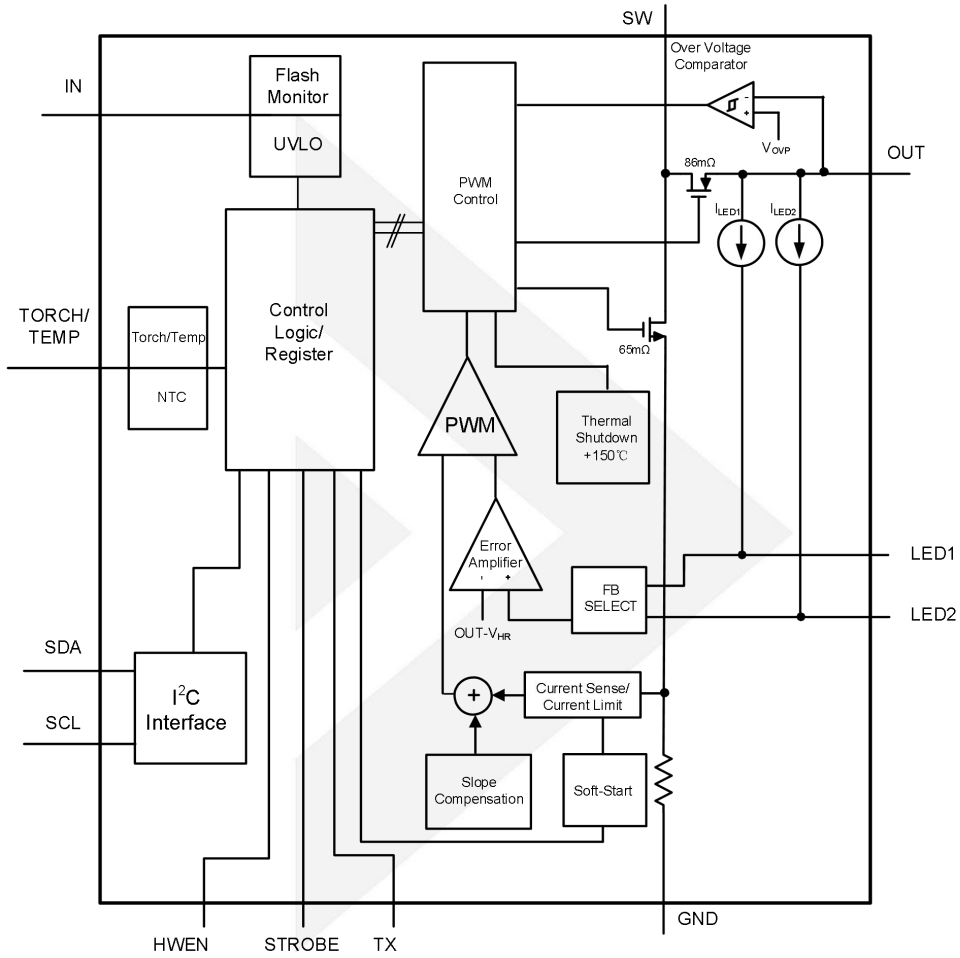

Figure 3. Functional block diagram



Application Circuit

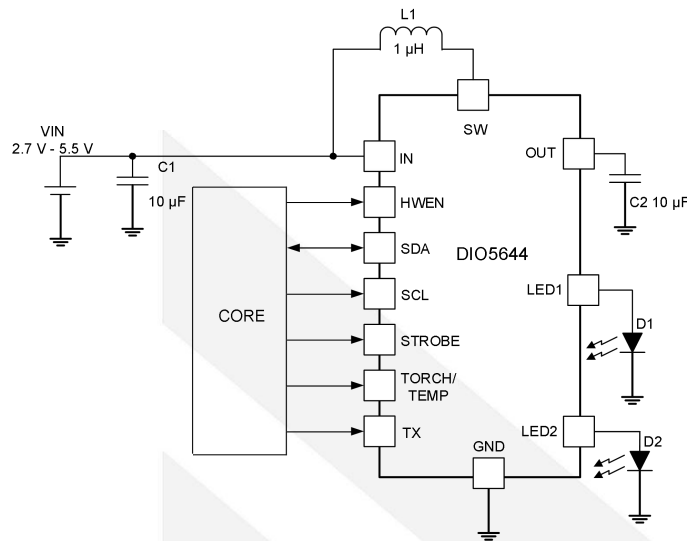

Figure 4. Application circuit

Operation Principle

Hardware enable and standby mode

The DIO5644 device can be enabled or disabled using the HWEN pin. When HWEN is low, the device enters shutdown mode, resets all I²C registers to default, and disables the I²C interface, rendering it unresponsive to any I²C commands. On the other hand, when HWEN is high, the device enters standby mode, enabling the I²C interface and allowing it to respond to I²C commands.

There are two kinds of power-up sequences, as shown in Figure 5 and Figure 6.

- If HWEN is tied to VIN, as soon as V_{IN} goes above around 2.0 V, HWEN should stay high for almost t_{wait} = 150 µs time before any I²C command can be accepted.
- If HWEN is driven by a GPIO, as soon as HWEN goes from low to high, HWEN should stay high for almost t_{wait} = 150 µs time before receiving any I²C command.

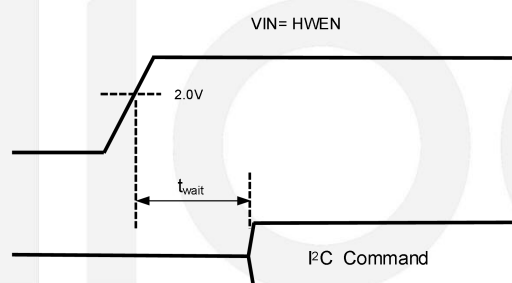

Figure 5. Power up sequence with HWEN tied to VIN

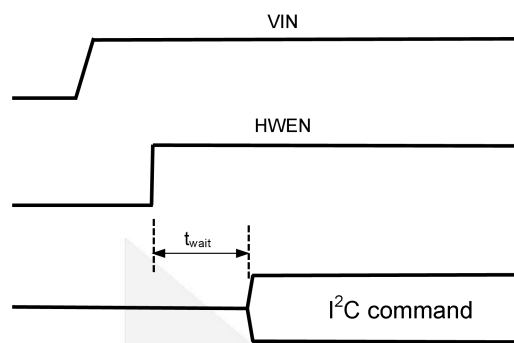

Figure 6. Power up sequence with HWEN driven by GPIO

The part can be turned off either using HWEN or an I²C command, but there are differences between the two methods. Turning off the part by setting HWEN low will immediately turn off the LED current without any ramp down control. After shutdown, the device's bias current will be approximately 0.1 μ A, and the I²C interface will be disabled. On the other hand, turning off the part using an I²C command while keeping HWEN high will allow for ramp down control of the LED current. Once the LED current ramp down is complete, the VIN pin current will be approximately 2.5 μ A, which is typical to keep the I²C interface active.

Flash mode

The LED current sources (LED1/2) in flash mode offer 128 target current levels ranging from 10.9 mA to 1.5 A. Upon activation of the flash sequence, the LED current source ramps up by stepping through each current level until it reaches the programmed current. The headroom in the two current sources can be regulated to provide 10.9 mA to 1.5 A on each of the two output legs. There is an option in the register settings to keep the two currents in the output leg the same.

When the device is enabled in flash mode through the enable register, all mode bits in the enable register are cleared after a flash time-out event.

Torch mode

The LED current sources (LED1/2) provide 128 target current levels from 0.977 mA to 179 mA or 1.954 mA to 358 mA in torch mode. The torch currents are adjusted via the LED1 and LED2 torch brightness registers. Torch mode can be activated by setting M1, M0 to '10' in the enable register, or by pulling the TORCH/TEMP pin high when the pin is enabled (enable register) and set to torch mode. The active current sources (LED1/2) ramp up as soon as the TORCH sequence is activated, stepping through all current levels until the programmed current is reached, with the ramp rate determined by the timing register value.

Torch mode is not affected by flash timeout or by a TX interrupt event.

IR mode

When the IR mode is enabled by setting M1, M0 to '01', the boost converter turns on and sets the output equal to the input in pass-mode. In this mode, the target LED current is equivalent to the value stored in the LED1/2 flash brightness registers. The STROBE pin controls the LED1/2 current sources, and it can only be set to be level sensitive, which means that the timing of the IR pulse is externally controlled. In IR mode, the current sources do not ramp the LED outputs to the target; instead, the current transitions immediately from off to on and then from on to off.

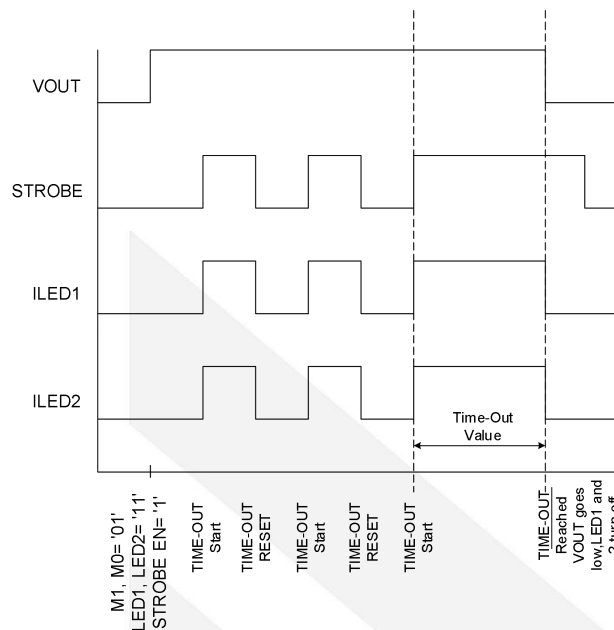

Figure 7. IR mode timeout

Device Functioning Modes

Start-up (enabling the device)

To activate the DIO5644 torch and flash modes, use the enable register. On start-up, when V_{OUT} is lower than V_{IN} , the internal synchronous PFET functions as a current source and provides 200 mA (typical) to the output capacitor. At this point, the current source (LED) is turned off. The current source turns on when the voltage on the output capacitor reaches 2.2 V (typical). Upon turn-on, the current source steps through each FLASH or TORCH level until it reaches the desired LED current, resulting in a controlled turn-on and limiting inrush current from the V_{IN} supply.

Pass mode

The DIO5644 begins its operation in pass mode, which it remains in until boost mode is necessary to maintain regulation. When the voltage difference between V_{OUT} and V_{LED} drops below V_{HR} , the device switches to boost mode. In pass mode, the boost converter remains inactive, and the synchronous PFET turns on completely, raising V_{OUT} to $(V_{IN} - I_{LED} \times R_{PMOS})$. The inductor current is not restricted by the peak current limit in pass mode.

Power amplifier synchronization (TX)

The TX pin serves as a synchronization input for the power amplifier. Its purpose is to decrease the flash LED current, limiting the battery current during high battery current conditions, such as PA transmission events. During a flash event in which the DIO5644 is engaged, pulling the TX pin high forces the LED current into torch mode, at the programmed torch current setting. If the TX pin is then pulled low before the flash pulse ends, the LED current returns to its previous flash current level. When the flash time-out concludes, the LED current turns off, regardless of whether the TX pin is high or low.

Input voltage flash monitor (IVFM)

The DIO5644 can modify the flash current based on the voltage level at the IN pin via the input voltage flash monitor (IVFM). The IVFM threshold can be adjusted from 2.9 V to 3.6 V in 100 mV steps, with a usage mode of up and down mode. In the up and down mode, the IVFM threshold value plus the hysteresis voltage threshold set the input voltage boundary that forces the DIO5644 to start ramping the flash current back up towards the target.

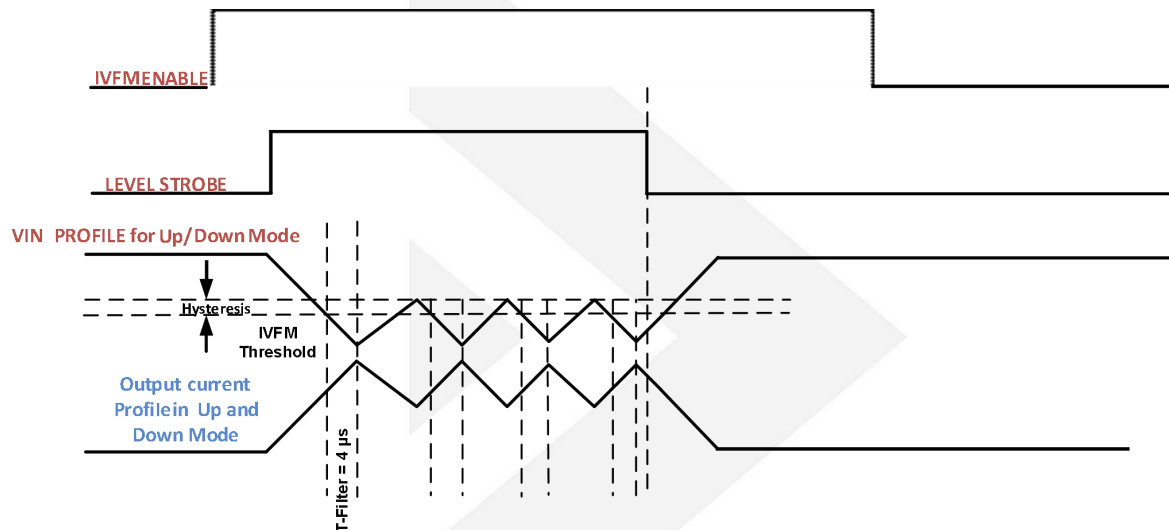

Figure 8. Up and Down mode

Fault operation

In the event that the DIO5644 experiences a fault condition, the device sets the corresponding flag in the flags1 and flags2 registers (0x0A and 0x0B) and enters standby mode by clearing the mode bits ([1],[0]) in the enable register. The DIO5644 remains in standby mode until the flags1 and flags2 registers are read via I²C. After the flags/faults are cleared, the device can be restarted for its intended purpose (flash, torch, IR, and so on). If the fault persists, the DIO5644 re-enters the fault state and returns to standby mode.

Flash time-out

The flash time-out period determines the duration during which the flash current is supplied by the current sources (LED1/2). The DIO5644 provides 16 timeout levels, which range from 10 ms to 400 ms or from 40 ms to 1600 ms (more information is available in the timing configuration register (0x08)).

Overvoltage protection (OVP)

The DIO5644 typically limits the output voltage to 5 V. If an open LED occurs, the DIO5644 raises the output voltage to maintain the LED current at the target value. Once V_{OUT} reaches 5 V (typical), the overvoltage comparator is triggered, causing the internal NFET to turn off. The DIO5644 resumes switching once V_{OUT} drops below the V_{OVP} off threshold. When there are three increasing OVP edges, the mode bits are cleared, and the OVP flag is set if an OVP condition is present. This prevents instantaneous OVP events from causing the device to shut down.

Current limit

The DIO5644 has two selectable inductor current limits that can be programmed through the I²C-compatible interface. When the inductor current limit is reached, the charging phase of the switching cycle is terminated, and switching resumes at the beginning of the next period. However, if the overcurrent condition persists, the device operates continuously in current limit mode.

It's important to note that the current limit is sensed in the NMOS switch, which means that there is no mechanism to limit the current when the device operates in pass mode since current does not flow through the NMOS in pass mode. In both boost mode and pass mode, if the V_{OUT} falls below 2.3 V, the device stops switching and the PFET acts as a current source, limiting the current to 200 mA. This mechanism is in place to prevent damage to the DIO5644 and excessive current being drawn from the battery during output short-circuit conditions.

Furthermore, the mode bits remain the same upon a current limit event, but a flag is set to indicate the occurrence of the event.

NTC thermistor input (TORCH/TEMP)

The TORCH/TEMP pin can be set to function in TEMP mode, where it acts as a threshold detector and bias source for negative temperature coefficient (NTC) thermistors. When the voltage at TEMP drops below the programmed threshold, the DIO5644 enters standby mode. The NTC threshold voltage can be adjusted from 200 mV to 900 mV in 100 mV increments, and the NTC bias current is set to a fixed value of 50 μ A. The NTC detection circuitry can be enabled or disabled through the enable register. If enabled, the NTC block turns on and off during the start and stop of a flash/torch event.

In addition, the NTC input is capable of detecting both open and shorted NTC connections. If the NTC input falls below 100 mV, the NTC short flag is set, and the device is disabled. Similarly, if the NTC input rises above 2.3 V, the NTC open flag is set, and the device is disabled. These fault detections can be independently enabled or disabled using the NTC open fault enable bit and the NTC short fault enable bit.

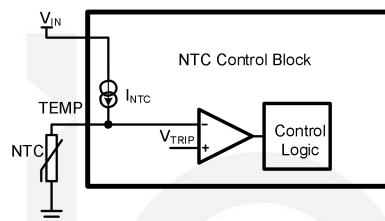

Figure 9. Temp detection diagram

Undervoltage lockout (UVLO)

The DIO5644 is equipped with an internal comparator that continuously monitors the voltage at the IN pin. If the input voltage drops to 2.5 V, the DIO5644 is forced into standby mode. In the event that the UVLO monitor threshold is triggered, the UVLO flag bit is set in the flags1 register (0x0A).

If the input voltage subsequently rises above 2.7 V, the DIO5644 cannot be operated until there is an I²C read of the flags1 register (0x0A). Once a read occurs, the flags1 register is cleared, and normal operation can resume as long as the input voltage is greater than 2.7 V.



DIO5644

Thermal shutdown (TSD)

If the temperature of the DIO5644 die reaches 150°C, the thermal shutdown detection circuit is activated, which causes the device to enter standby mode and sets the thermal shutdown bit to '1' in the flags1 register (0x0A). To resume normal operation, the flags1 register must be read to clear the fault flag.

If the die temperature is still above 150°C upon restart, the DIO5644 will reset the fault flag and re-enter standby mode. This process will continue until the die temperature drops below the threshold value.

LED and VOUT short fault

If the DIO5644 is operating in flash or torch mode and either LED output experiences a short condition, the LED fault flags will read back a '1'. Similarly, if the boost output experiences a short condition while the device is in flash or torch mode, the output short fault flag will read back a '1'.

To determine an LED short condition, the voltage at LED1 or LED2 must drop below 500 mV(typ.) when the device is in torch or flash mode. There is a deglitch time of 256 μs before the LED short flag becomes valid and a deglitch time of 2.048 ms before the VOUT short flag becomes valid.

To reset the LED short faults to '0', power must be removed from the DIO5644, HWEN must be set to '0', the software reset bit must be set to '1', or the flags1 register must be read back. Additionally, the mode bits are cleared when an LED and/or V_{OUT} short fault occurs.

Programming

Control truth table

Mode1	Mode0	STROBE EN	TORCH EN	STROBE pin	TORCH pin	Action
0	0	0	0	X	X	Standby
0	0	0	1	X	pos edge	Ext torch
0	0	1	0	pos edge	X	Ext flash
0	0	1	1	0	pos edge	Standalone torch
0	0	1	1	pos edge	pos edge	Standalone flash
0	0	1	1	pos edge	X	Standalone flash
1	0	X	X	X	X	Int torch
1	1	X	X	X	X	Int flash
0	1	0	X	X	X	IRLED standby
0	1	1	X	0	X	IRLED standby
0	1	1	X	pos edge	X	IRLED enable

I²C compatible chip address

The DIO5644 device address is set to 1100011 (0x63). To communicate with the device through the I²C-compatible interface, the master must first send a START condition. After the START condition, the master sends the 7-bit device address followed by an eighth bit that indicates whether the operation is a READ or

WRITE. Specifically, setting R/W to 0 indicates a WRITE operation while setting R/W to 1 indicates a READ operation.

Following the device address and R/W bit, the second byte specifies the address of the register to which the data will be written. Finally, the third byte contains the data to be written to the selected register.

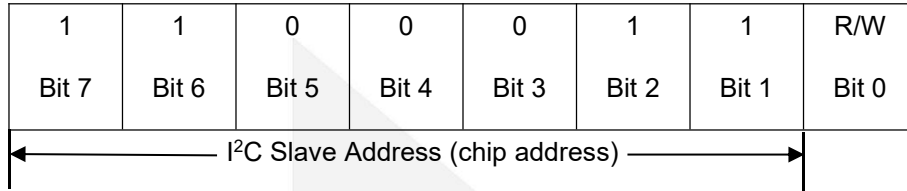

Figure 10. I²C compatible chip address

Register descriptions

Register Name	Internal HEX Address	Power ON/Reset Value
		DIO5644
Enable register	0x01	0x80
IVFM register	0x02	0x01
LED1 flash brightness register	0x03	0xBF
LED2 flash brightness register	0x04	0x3F
LED1 torch brightness register	0x05	0xBF
LED2 torch brightness register	0x06	0x3F
Boost configuration Register	0x07	0x09
Timing configuration Register	0x08	0x1A
TEMP register	0x09	0x08
Flags1 register	0x0A	0x00
Flags2 register	0x0B	0x00
Device ID register	0x0C	0x02

Enable register (0x01)

Bits	Name	Default	Description
7	TX Pin Enable	1	0 = Disabled 1 = Enabled
6	Strobe Type	0	0 = Level Triggered 1 = Edge Triggered
5	Strobe Enable	0	0 = Disabled 1 = Enabled
4	TORCH/TEMP Pin Enable	0	0 = Disabled 1 = Enabled
3:2	Mode Bits: M1, M0	00	00 = Standby 01 = IR Drive 10 = Torch



DIO5644

			11 = Flash
1	LED2 Enable	0	0 = OFF 1 = ON
0	LED1 Enable	0	0 = OFF 1 = ON

IVFM register (0x02)

Bits	Name	Default	Description
7	Reserved		
6	UVLO Circuitry	0	0 = Disabled 1 = Enabled
5:3	IVFM Levels	000	000 = 2.9 V 001 = 3 V 010 = 3.1 V 011 = 3.2 V 100 = 3.3 V 101 = 3.4 V 110 = 3.5 V 111 = 3.6 V
2	IVFM Hysteresis	0	0 = 0 mV 1 = 100 mV
1:0	IVFM Selection	01	00 = Disabled 01 = Up and Down Mode

LED1 flash brightness register (0x03)

Bits	Name	Default	Description
7	LED2 Flash Current Override	1	0 = LED2 Flash Current is not set to LED1 Flash Current 1 = LED2 Flash Current is set to LED1 Flash Current
6:0	LED1 Flash Brightness Level	0111111	$I_{FLASH1/2} \text{ (mA)} \approx (\text{Brightness Code} \times 11.725 \text{ mA}) + 10.9 \text{ mA}$ 0000000 = 10.9 mA 0111111 = 750 mA 1111111 = 1.5 A

LED2 flash brightness register (0x04)

Bits	Name	Default	Description
7	Reserved		
6:0	LED1 Flash Brightness Level	0111111	$I_{FLASH1/2} \text{ (mA)} \approx (\text{Brightness Code} \times 11.725 \text{ mA}) + 10.9 \text{ mA}$ 0000000 = 10.9 mA 0111111 = 750 mA 1111111 = 1.5 A

LED1 torch brightness register (0x05)

Bits	Name	Default	Description
7	LED2 Torch Current Override	1	0 = LED2 Torch Current is not set to LED1 Torch Current 1 = LED2 Torch Current is set to LED1 Torch Current
6:0	LED1 Flash Brightness Level	0111111	$I_{TORCH1/2} \text{ (mA)} \approx (\text{Brightness Code} \times 1.45 \text{ mA}) + 0.97 \text{ mA}$ 0000000 = 0.97 mA 0111111 = 92.5 mA 1111111 = 179 mA

LED2 torch brightness register (0x06)

Bits	Name	Default	Description
7	Torch Current Double Bit	0	0= Torch current*1 1=Torch current*2
6:0	LED1 Flash Brightness Level	0111111	$I_{TORCH1/2} \text{ (mA)} \approx (\text{Brightness Code} \times 1.45 \text{ mA}) + 0.97 \text{ mA}$ 0000000 = 0.97 mA 0111111 = 92.5 mA 1111111 = 179 mA

Boost Configuration Register (0x07)

Bits	Name	Default	Description
7	Software Reset	0	0 = Not Reset 1 = Reset (The I ² C communication is interrupted during the process.)



DIO5644

6:4	Reserved		
3	LED Pin Short Fault Detect	1	0 = Disable 1 = Enable
2	Boost Mode	0	0 = Normal 1 = Pass Mode Only
1	Boost Frequency Select	0	0 = 2 MHz 1 = 4 MHz
0	Boost Current Limit Setting	1	0 = 2.7 A 1 = 3.8 A

Timing Configuration Register (0x08)

Bits	Name	Default	Description
7	Flash Time Quadruple	0	0 = flash time*1 1 = flash time*4
6:4	Torch Current Ramp Time	001	000 = No Ramp 001 = 1 ms 010 = 32 ms 011 = 64 ms 100 = 128 ms 101 = 256 ms 110 = 512 ms 111 = 1024 ms
3:0	Flash Time-Out Duration	1010	0000 = 10 ms 0001 = 20 ms 0010 = 30 ms 0011 = 40 ms 0100 = 50 ms 0101 = 60 ms 0110 = 70 ms 0111 = 80 ms 1000 = 90 ms 1001 = 100 ms 1010 = 150 ms 1011 = 200 ms 1100 = 250 ms 1101 = 300 ms 1110 = 350 ms 1111 = 400 ms

TEMP register (0x09)

Bits	Name	Default	Description
7	Reserved		
6	TORCH Polarity	0	0 = Active High (Pull-down Resistor Enabled) 1 = Active Low (Pull-down Resistor Disabled)
5	NTC Open Fault Enable	0	0 = Disabled 1 = Enable
4	NTC Short Fault Enable	0	0 = Disabled 1 = Enable
3:1	TEMP Detect Voltage Threshold	100	000 = 0.2 V 001 = 0.3 V 010 = 0.4 V 011 = 0.5 V 100 = 0.6 V 101 = 0.7 V 110 = 0.8 V 111 = 0.9 V
0	TORCH/TEMP Function Select	0	0 = TORCH 1 = TEMP

Flags1 register (0x0A)

Bit 7	Bit 6	Bit 5	Bit 4	Bit 3	Bit 2	Bit 1	Bit 0
TX Flag	V _{OUT} Short Fault	VLED1 Short Fault	VLED2 Short Fault	Current Limit Flag	Thermal Shutdown (TSD) Fault	UVLO Fault	Flash Time-Out Flag

Flags2 register (0x0B)

Bit 7	Bit 6	Bit 5	Bit 4	Bit 3	Bit 2	Bit 1	Bit 0
Reserved	Reserved	Reserved	NTC Short Fault	NTC Open Fault	IVFM Trip Flag	OVP Fault	TEMP Trip Fault

Device ID register (0x0C)

Bit 7	Bit 6	Bit 5	Bit 4	Bit 3	Bit 2	Bit 1	Bit 0
Reserved	Reserved	Device ID '000'			Silicon Revision Bit '010'		

Detailed Design Procedure**Output capacitor selection**

To ensure stable operation of the DIO5644, it is designed to be used with a 10 μF ceramic output capacitor. During operation of the boost converter, the output capacitor supplies the load current while the NMOS switch is on. However, when the NMOS switch turns off, the inductor energy is discharged through the internal PMOS switch, which supplies power to the load and simultaneously restores charge to the output capacitor. As a result of this process, the output voltage experiences a sag during the on-time and a rise during the off-time.

To limit output ripple to an acceptable level, the output capacitor is carefully selected depending on the load current, input/output voltage differentials, and other relevant factors. The output capacitor's specifications are chosen to ensure that the converter remains stable and operates within acceptable limits.

If lower output voltage ripple is desired, larger capacitors such as a 22 μF or capacitors connected in parallel can be used. To estimate the output voltage ripple, two factors must be considered: the ripple due to capacitor discharge (ΔV_Q) and the ripple due to the capacitor's equivalent series resistance (ΔV_{ESR}). The following equations can be used to estimate these ripples.

For continuous conduction mode, the output voltage ripple due to capacitor discharge is calculated using Equation 1:

$$\Delta V_Q = \frac{I_{LED} \times (V_{OUT} - V_{IN})}{f_{SW} \times V_{OUT} \times C_{OUT}} \quad 1$$

The output voltage ripple due to the output capacitors ESR is found by Equation 2:

$$\Delta V_{ESR} = R_{ESR} \times \left(\frac{I_{LED} \times V_{OUT}}{V_{IN}} + \Delta I_L \right) \quad 2$$

where

$$\Delta I_L = \frac{V_{IN} \times (V_{OUT} - V_{IN})}{2 \times f_{SW} \times L \times V_{OUT}}$$

In ceramic capacitors, the ESR is very low so the assumption is that 80% of the output voltage ripple is due to capacitor discharge and 20% of the output voltage ripple is from ESR.

Input capacitor selection

To minimize voltage ripple caused by the switching of the DIO5644 boost converter and reduce noise on the input pin, it is important to choose the correct size and type of input capacitor. In the typical application circuit for the DIO5644, a 10 μF ceramic input capacitor is recommended.

To achieve optimal results, it is important to place the input capacitor as close as possible to the DIO5644 input

(IN) pin. This helps reduce the series resistance and inductance that can inject noise into the device due to the input switching currents. By minimizing the noise on the input pin, the potential for disruption to internal analog signals is also reduced.

Inductor selection

The DIO5644 boost converter is designed to operate with a 0.47 μH or 1 μH inductor. During boosting (when the output voltage V_{OUT} is greater than the input voltage V_{IN}), the inductor typically represents the largest area of efficiency loss in the circuit. Therefore, it is important to choose an inductor with the lowest possible series resistance.

When selecting an inductor for use with the DIO5644, it is important to ensure that the inductor's saturation rating is greater than the maximum operating peak current of the DIO5644. This is necessary to prevent excess efficiency loss that can occur when inductors operate in saturation.

To ensure proper inductor operation and circuit performance, it is important to choose an inductor with a saturation current and a peak current limit setting that are greater than the value obtained from the following Equation 3:

$$I_{PEAK} = \frac{I_{LOAD}}{\eta} \times \frac{V_{OUT}}{V_{IN}} + \Delta I_L \quad 3$$

where

$$\Delta I_L = \frac{V_{IN} \times (V_{OUT} - V_{IN})}{2 \times f_{SW} \times L \times V_{OUT}}$$

where

$$f_{SW} = 2 \text{ or } 4 \text{ MHz}$$

Efficiency details can be found in the Typical Performance Characteristics.

Choose inductor listed in the table below when $I_{LED} = 1.5 \text{ A}$.

Recommend Power Inductor and Parameters

Manufacture	P/N	Inductance	DCR	I_{sat} (A)		I_{rms} (A)		Dimension
		μH	Ω	Max	Typ	Max	Typ	mm
Sunlord	WPN201610H1R0MT	1.0 \pm 20%	0.075	3.35	3.85	2.05	2.35	2.0 \times 1.6 \times 1.0
Sunlord	WPN252010H1R0MT	1.0 \pm 20%	0.076	3.10	3.50	2.50	2.90	2.5 \times 2.0 \times 1.0
Sunlord	WPN252012H1R0MT	1.0 \pm 20%	0.054	3.60	4.20	3.00	3.40	2.5 \times 2.0 \times 1.2

Power supply recommendations

The DIO5644 is designed to operate with an input voltage supply range of 2.7 V to 5.5 V. It is important to ensure that the input supply is well regulated and capable of supplying the required input current.

If the input supply is located far from the DIO5644, additional bulk capacitance may be required in addition to

the ceramic bypass capacitors. This is because the additional capacitance will help reduce the voltage drop caused by the resistance and inductance in the power supply trace. By reducing the voltage drop, the potential for noise and other disruptions to the device's operation is also reduced.

Layout guidelines

The high switching frequency and large switching currents of the DIO5644 make the choice of layout very important. The following steps should be used for reference to ensure the device is stable and maintains proper LED current regulation across its intended operating voltage and current range.

- Place CIN on the top layer, as close to the device as possible, and connect it through short, wide traces to both the IN and GND pins.
- Place COUT on the top layer, as close as possible to the OUT and GND pins, and connect the returns for both CIN and COUT at one point, as close to the GND pin as possible.
- Connect the inductor on the top layer, close to the SW pin, with a low-impedance connection from the inductor to SW, and minimize the area occupied by the SW node to reduce capacitive coupling of the high dV/dT present at SW.
- Avoid routing logic traces near the SW node to prevent any capacitive coupled voltages from SW onto any high-impedance logic lines, and insert an inner layer GND plane underneath the SW node and between any nearby routed traces to create a shield from the electric field generated at SW.
- Terminate the flash LED cathodes directly to the GND pin of the DIO5644, and route the LED returns with a dedicated path to keep the high amplitude LED currents out of the GND plane. For flash LEDs that are routed relatively far away from the DIO5644, sandwich the forward and return current paths over the top of each other on two layers to reduce the inductance of the LED current paths.

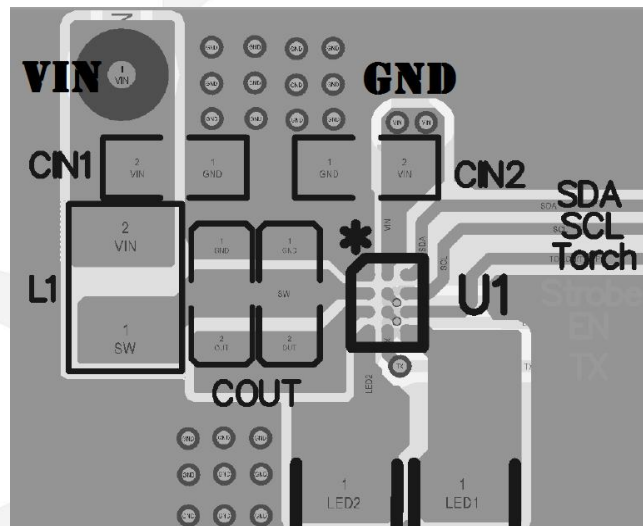

Figure 12. Layout example

Typical Performance Characteristics

Ambient temperature is 25°C, input voltage is 3.6 V, $HWEN = V_{IN}$, $C_{IN} = C_{OUT} = 1 \times 10 \mu F$ and $L = 1 \mu H$, unless otherwise noted.

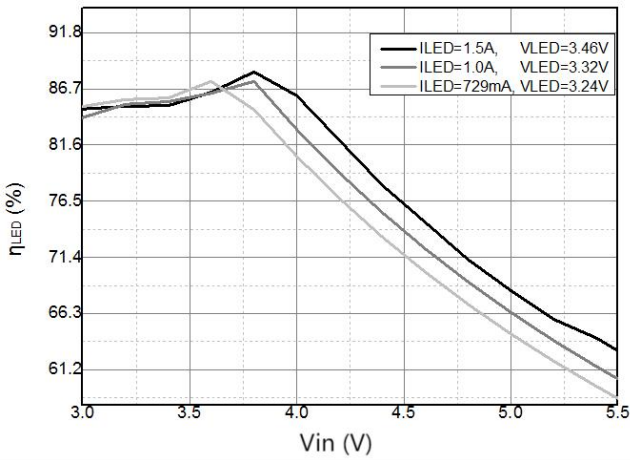

Figure 13. Flash mode LED efficiency

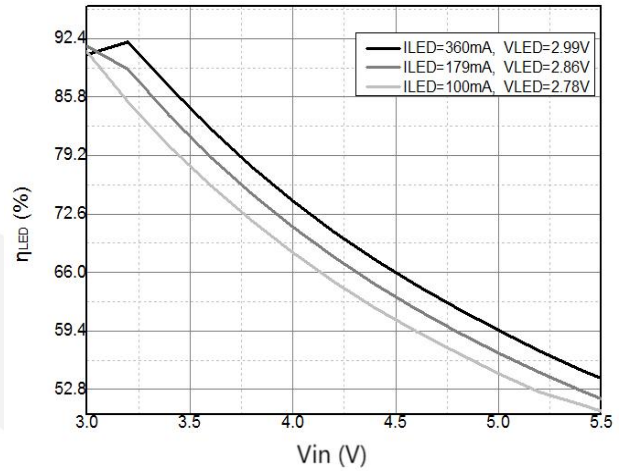

Figure 14. Torch mode LED efficiency

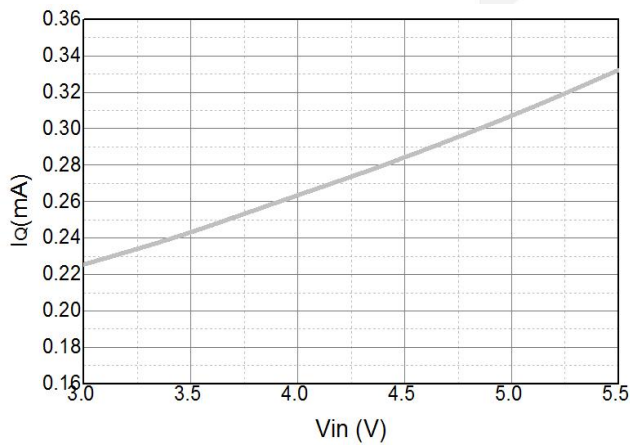

Figure 15. Quiescent current vs. Input voltage

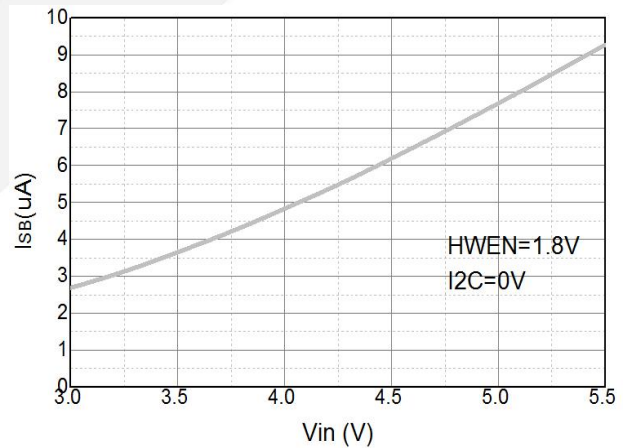

Figure 16. Standby current vs. Input voltage

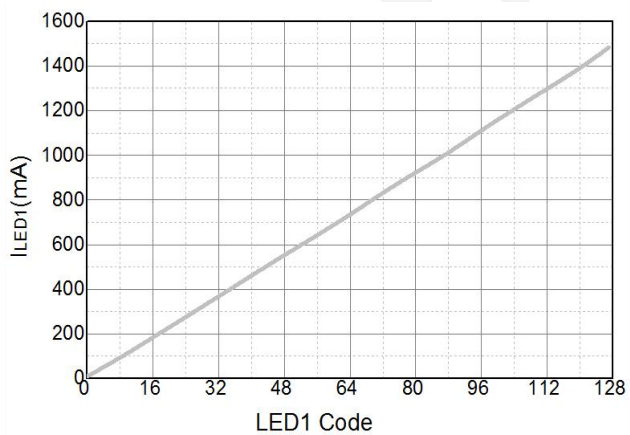

Figure 17. LED1 flash current vs. Brightness code

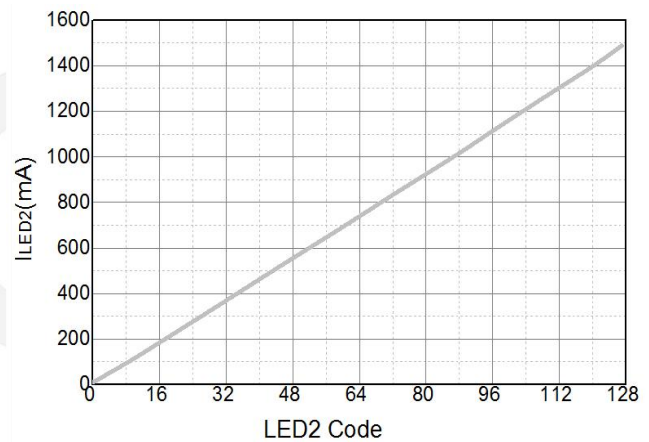

Figure 18. LED2 flash current vs. Brightness code

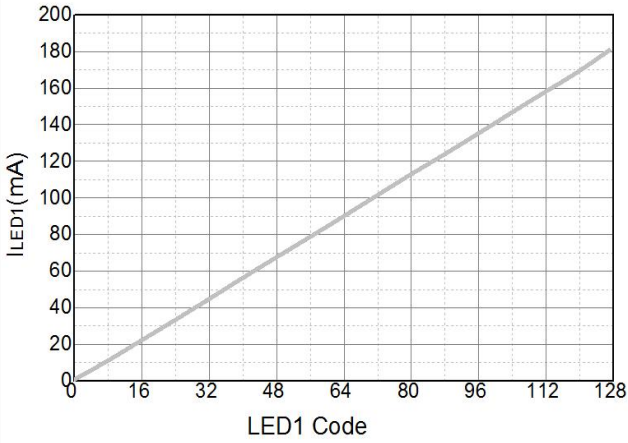

Figure 19. LED1 torch current vs. Brightness code

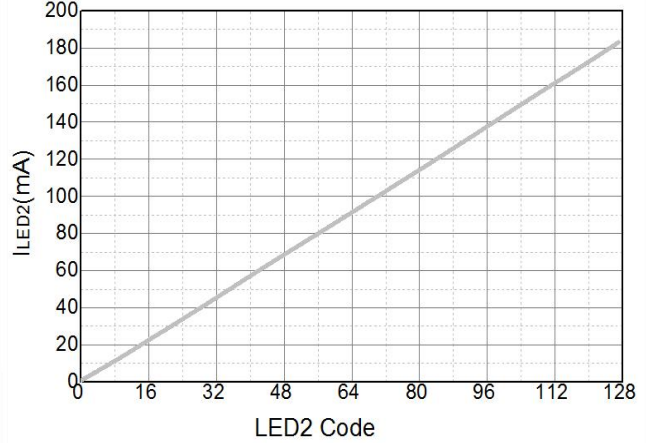

Figure 20. LED2 torch current vs. Brightness code

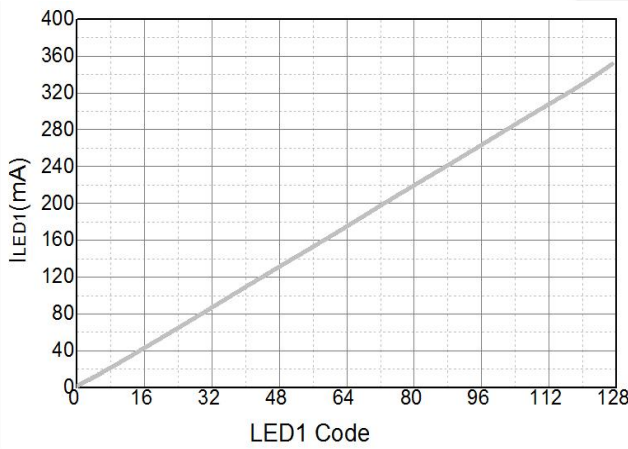

Figure 21. LED1 torch current x2 vs. Brightness code

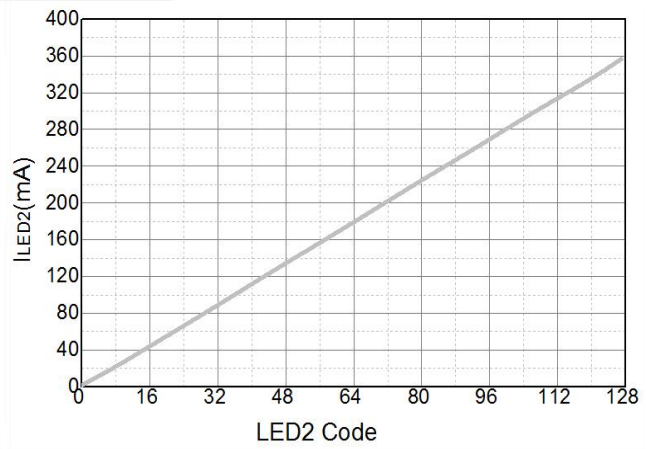

Figure 22. LED2 torch current x2 vs. Brightness code

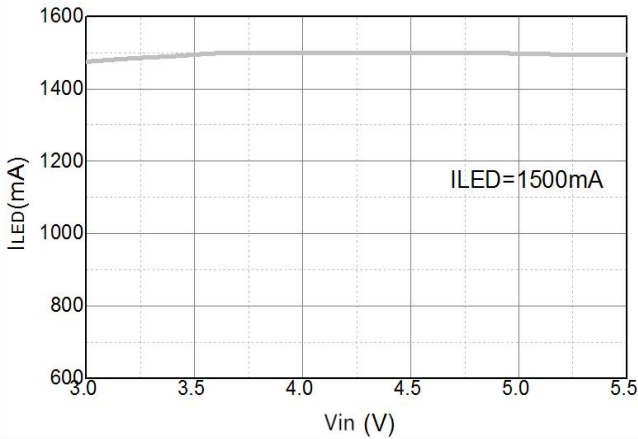

Figure 23. Flash mode LED current vs. Input voltage

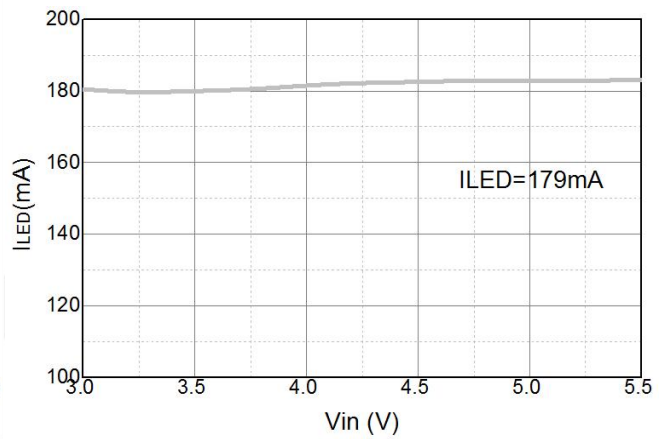
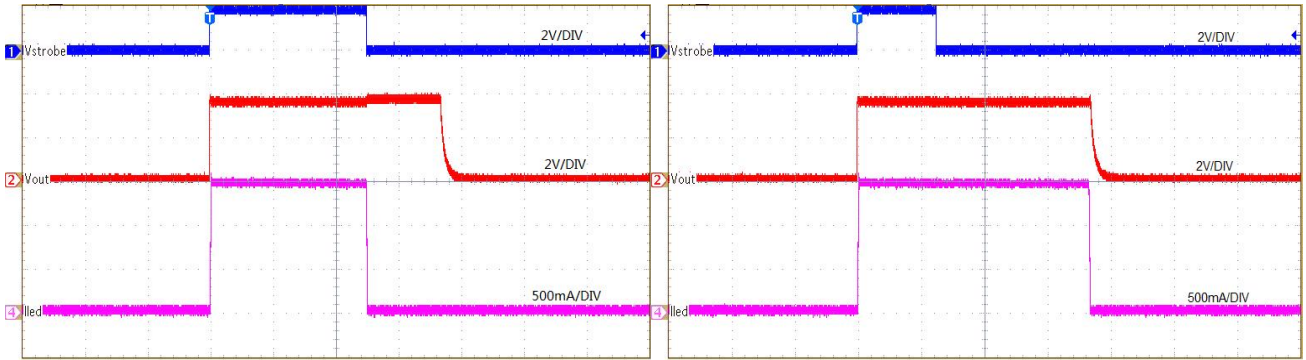

Figure 24. Torch mode LED current vs. Input voltage



Time (40 ms/DIV)

Figure 25. STROBE pin turn-on flash mode (level)

Time (40 ms/DIV)

Figure 26. STROBE pin turn-on flash mode (edge)

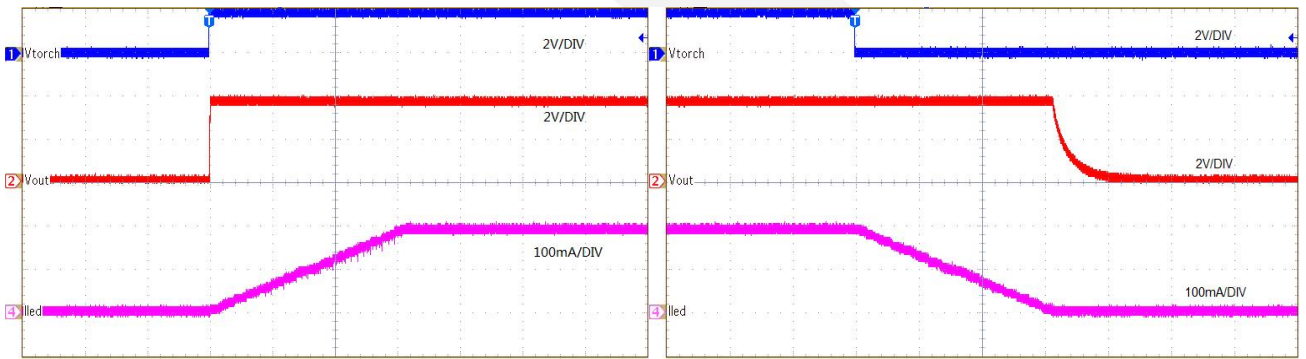

Time (10 ms/DIV)

Figure 27. Torch pin turn-on torch mode (Ramp = 32 ms)

Time (10 ms/DIV)

Figure 28. Torch pin turn-off torch mode (Ramp = 32 ms)

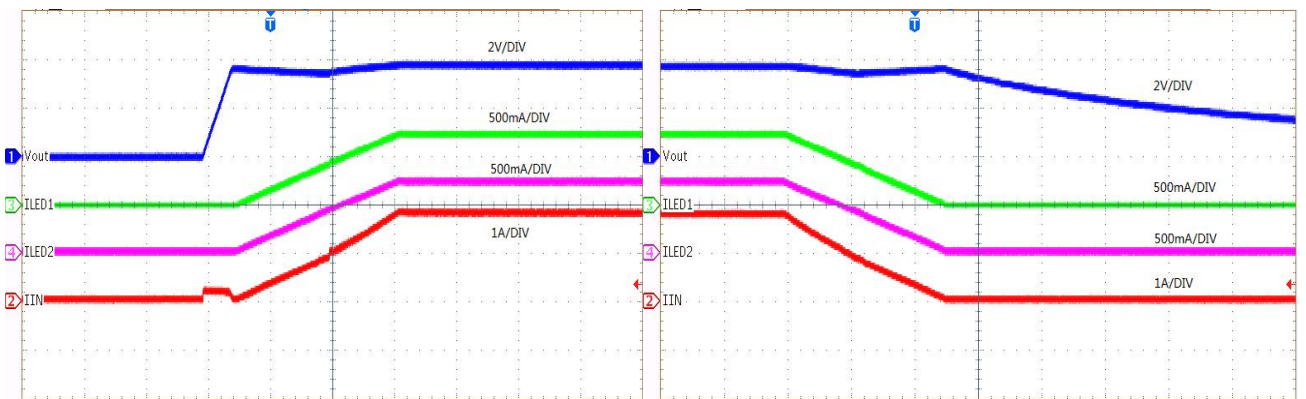

Time (400 us/DIV)

Figure 29. Start-up

Time (400 us/DIV)

Figure 30. Ramp down

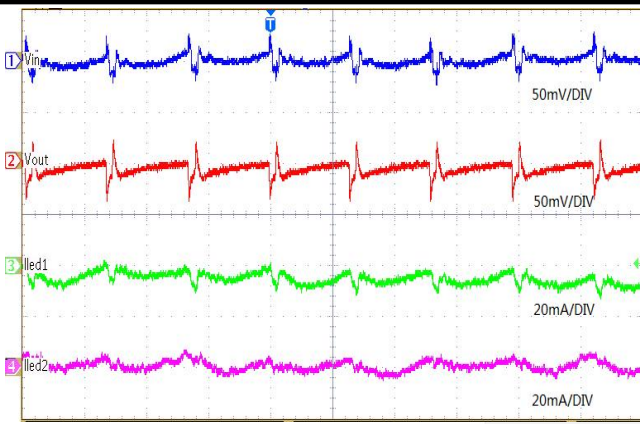

Time (400 ns/DIV)

Figure 31. Ripple at 2 MHz

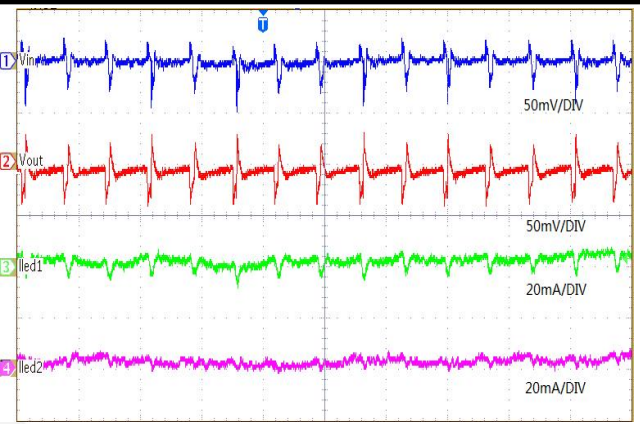

Time (400 ns/DIV)

Figure 32. Ripple at 4 MHz

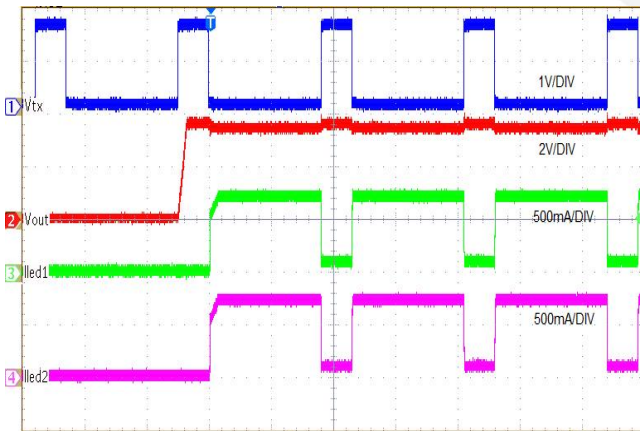

Time (2 ms/DIV)

Figure 33. TX function



Physical Dimensions: WLCSP-12

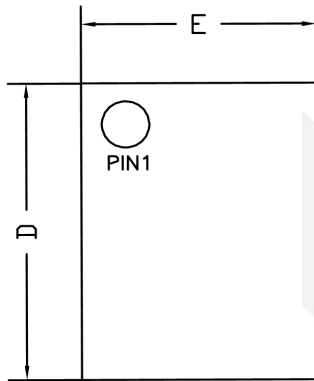

TOP VIEW
(MARK SIDE)

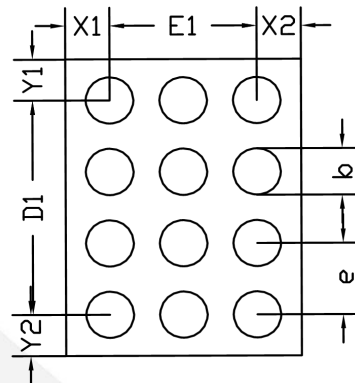

BOTTOM VIEW
(BALL SIDE)

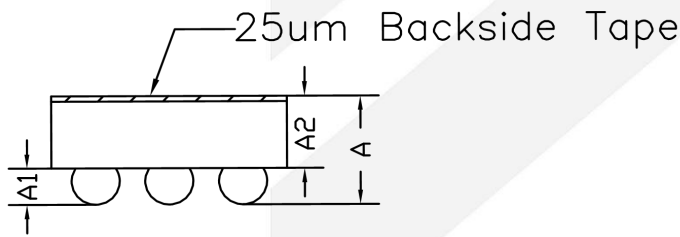

SIDE VIEW

NOTES:
ALL WAFER ORIENTATION NOTCH DOWN

Common Dimensions (Units of Measure = Millimeter)			
Symbol	Min	Nom	Max
A	0.560	0.605	0.650
A1	0.175	0.200	0.225
A2	0.385	0.405	0.425
D	1.630	1.660	1.690
D1	1.200 BSC		
E	1.250	1.280	1.310
E1	0.800 BSC		
b	0.235	0.260	0.285
e	0.400 BSC		
X1	0.240 REF		
X2	0.240 REF		
Y1	0.230 REF		
Y2	0.230 REF		



DIO5644

Dual 1.5 A Current Source Camera Flash LED Driver

CONTACT US

Dioo is a professional design and sales corporation for high-quality and performance analog semiconductors. The company focuses on industry markets, such as cell phones, handheld products, laptops, medical equipment, and so on. Dioo's product families include analog signal processing and amplifying, LED drivers, and charger ICs. Go to <http://www.dioo.com> for a complete list of Dioo product families.

For additional product information or full datasheet, please contact our sales department or representatives.

dioo

Looking for pricing, stock, or lifecycle information?

Click below to explore more details on WIN SOURCE:

 [View DIO5644WL12 on WIN SOURCE](#)

 [dioo Information](#)

Optimize Your Supply Chain with WIN SOURCE Solutions

-  Global Sourcing Solution
-  Obsolete Management
-  Cost Control Management
-  Shortage Management
-  Alternative Solution
-  Excess Inventory Management