



**THE DATASHEET OF
PCA9544APW,112**





PCA9544A

4-channel I²C-bus multiplexer with interrupt logic

Rev. 5 — 23 April 2014

Product data sheet

1. General description

The PCA9544A is a 1-of-4 bidirectional translating multiplexer, controlled via the I²C-bus. The SCL/SDA upstream pair fans out to four SCx/SDx downstream pairs, or channels. Only one SCx/SDx channel is selected at a time, determined by the contents of the programmable control register. Four interrupt inputs, $\overline{INT0}$ to $\overline{INT3}$, one for each of the SCx/SDx downstream pairs, are provided. One interrupt output, \overline{INT} , which acts as an AND of the four interrupt inputs, is provided.

A power-on reset function puts the registers in their default state and initializes the I²C-bus state machine with no channels selected.

The pass gates of the multiplexer are constructed such that the V_{DD} pin can be used to limit the maximum high voltage which is passed by the PCA9544A. This allows the use of different bus voltages on each SCx/SDx pair, so that 1.8 V, 2.5 V or 3.3 V parts can communicate with 5 V parts without any additional protection. External pull-up resistors pull the bus up to the desired voltage level for each channel. All I/O pins are 5 V tolerant.

2. Features and benefits

- 1-of-4 bidirectional translating multiplexer
- I²C-bus interface logic; compatible with SMBus
- 4 active LOW interrupt inputs
- Active LOW interrupt output
- 3 address pins allowing up to 8 devices on the I²C-bus
- Channel selection via I²C-bus
- Power-up with all multiplexer channels deselected
- Low R_{on} switches
- Allows voltage level translation between 1.8 V, 2.5 V, 3.3 V and 5 V buses
- No glitch on power-up
- Supports hot insertion
- Low standby current
- Operating power supply voltage range of 2.3 V to 5.5 V
- 5 V tolerant Inputs
- 0 Hz to 400 kHz clock frequency
- ESD protection exceeds 2000 V HBM per JESD22-A114 and 1000 V CDM per JESD22-C101
- Latch-up testing is done to JEDEC Standard JESD78 which exceeds 100 mA
- Three packages offered: SO20, TSSOP20 and HVQFN20



3. Ordering information

Table 1. Ordering information

Type number	Topside marking	Package		
		Name	Description	Version
PCA9544ABS	9544A	HVQFN20	plastic thermal enhanced very thin quad flat package; no leads; 20 terminals; body 5 × 5 × 0.85 mm	SOT662-1
PCA9544AD	PCA9544AD	SO20	plastic small outline package; 20 leads; body width 7.5 mm	SOT163-1
PCA9544APW	PA9544A	TSSOP20	plastic thin shrink small outline package; 20 leads; body width 4.4 mm	SOT360-1

3.1 Ordering options

Table 2. Ordering options

Type number	Orderable part number	Package	Packing method	Minimum order quantity	Temperature range
PCA9544ABS	PCA9544ABS,118	HVQFN20	Reel 13" Q1/T1 *Standard mark SMD	6000	T _{amb} = -40 °C to +85 °C
PCA9544AD	PCA9544AD,112	SO20	Standard marking * IC's tube - DSC bulk pack	1520	T _{amb} = -40 °C to +85 °C
	PCA9544AD,118	SO20	Reel 13" Q1/T1 *Standard mark SMD	2000	T _{amb} = -40 °C to +85 °C
PCA9544APW	PCA9544APW,112	TSSOP20	Standard marking * IC's tube - DSC bulk pack	1875	T _{amb} = -40 °C to +85 °C
	PCA9544APW,118	TSSOP20	Reel 13" Q1/T1 *Standard mark SMD	2500	T _{amb} = -40 °C to +85 °C

4. Block diagram

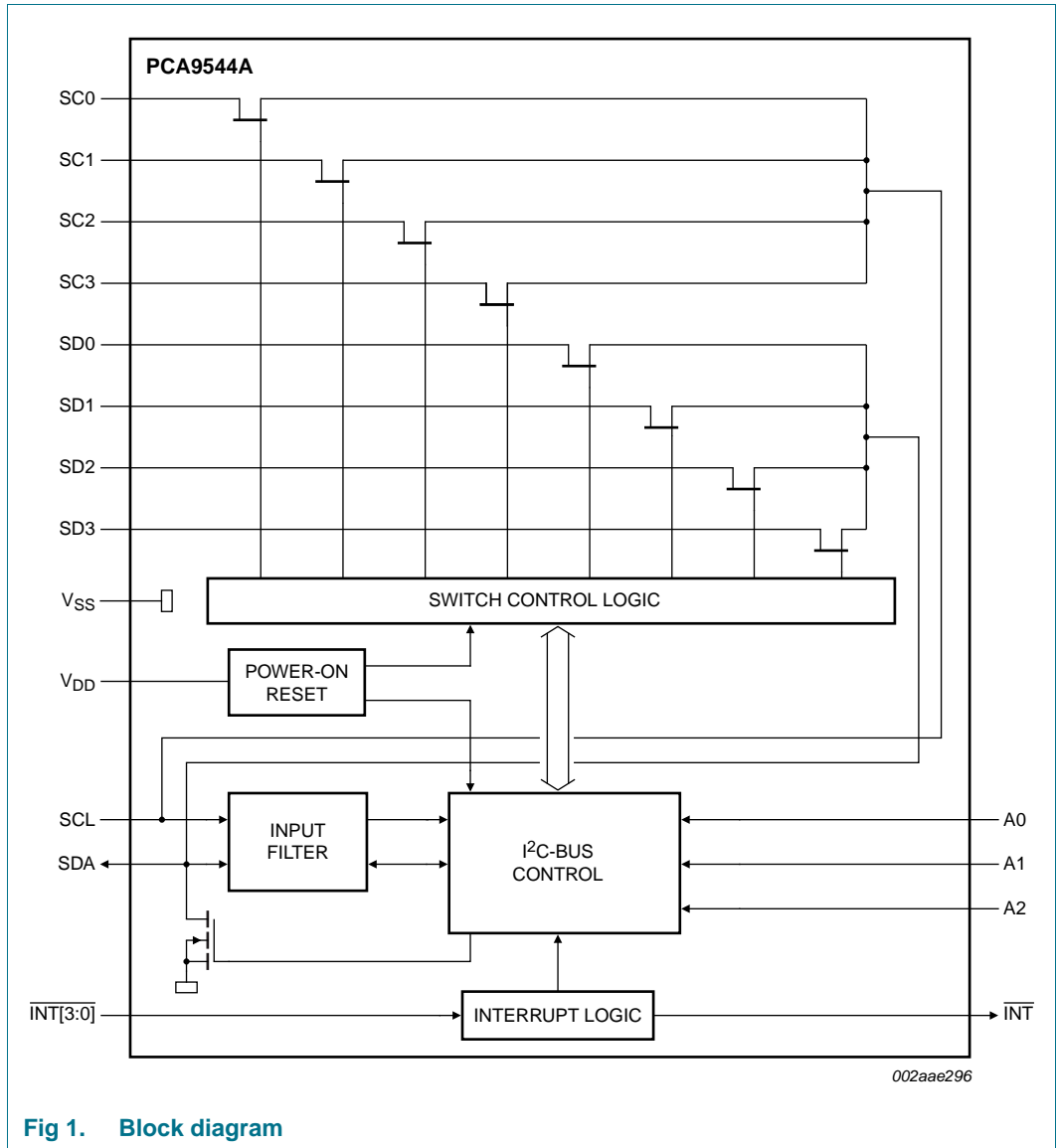
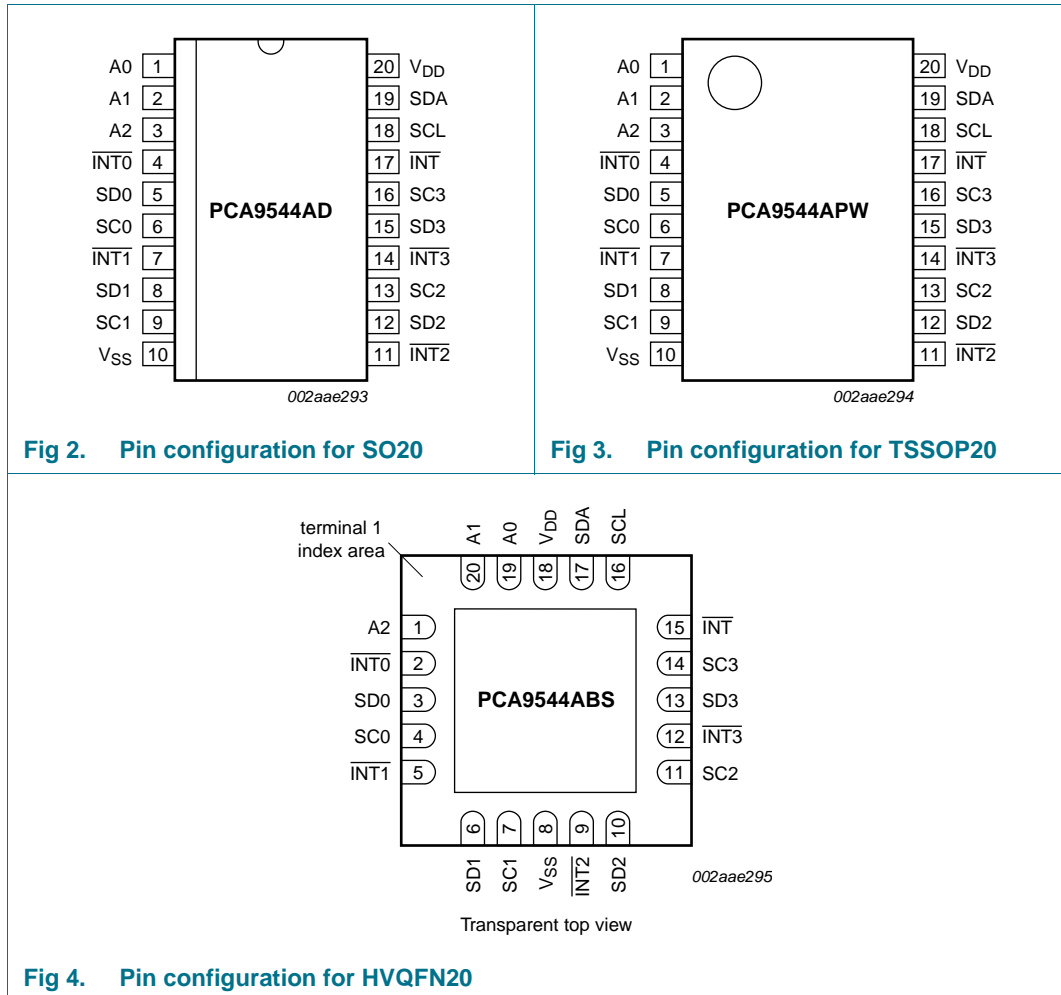

Fig 1. Block diagram

5. Pinning information

5.1 Pinning



5.2 Pin description

Table 3. Pin description

Symbol	Pin		Description
	SO20, TSSOP20	HVQFN20	
A0	1	19	address input 0
A1	2	20	address input 1
A2	3	1	address input 2
$\overline{\text{INT0}}$	4	2	active LOW interrupt input 0
SD0	5	3	serial data 0
SC0	6	4	serial clock 0
$\overline{\text{INT1}}$	7	5	active LOW interrupt input 1
SD1	8	6	serial data 1
SC1	9	7	serial clock 1
V _{SS}	10	8 ^[1]	supply ground
$\overline{\text{INT2}}$	11	9	active LOW interrupt input 2
SD2	12	10	serial data 2
SC2	13	11	serial clock 2
$\overline{\text{INT3}}$	14	12	active LOW interrupt input 3
SD3	15	13	serial data 3
SC3	16	14	serial clock 3
$\overline{\text{INT}}$	17	15	active LOW interrupt output
SCL	18	16	serial clock line
SDA	19	17	serial data line
V _{DD}	20	18	supply voltage

- [1] HVQFN20 package supply ground is connected to both V_{SS} pin and exposed center pad. V_{SS} pin must be connected to supply ground for proper device operation. For enhanced thermal, electrical, and board level performance, the exposed pad must be soldered to the board using a corresponding thermal pad on the board and for proper heat conduction through the board, thermal vias must be incorporated in the PCB in the thermal pad region.

6. Functional description

Refer to [Figure 1 “Block diagram”](#).

6.1 Device addressing

Following a START condition the bus master must output the address of the slave it is accessing. The address of the PCA9544A is shown in [Figure 5](#). To conserve power, no internal pull-up resistors are incorporated on the hardware selectable address pins and they must be pulled HIGH or LOW.

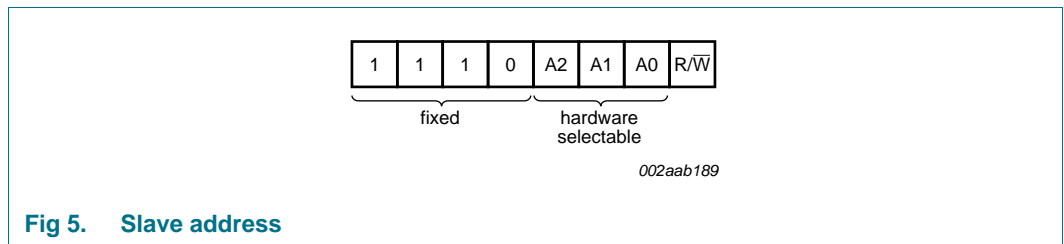

Fig 5. Slave address

The last bit of the slave address defines the operation to be performed. When set to logic 1 a read is selected, while a logic 0 selects a write operation.

6.2 Control register

Following the successful acknowledgement of the slave address, the bus master sends a byte to the PCA9544A which is stored in the Control register. If the PCA9544A receives multiple bytes, it saves the last byte received. This register can be written and read via the I²C-bus.

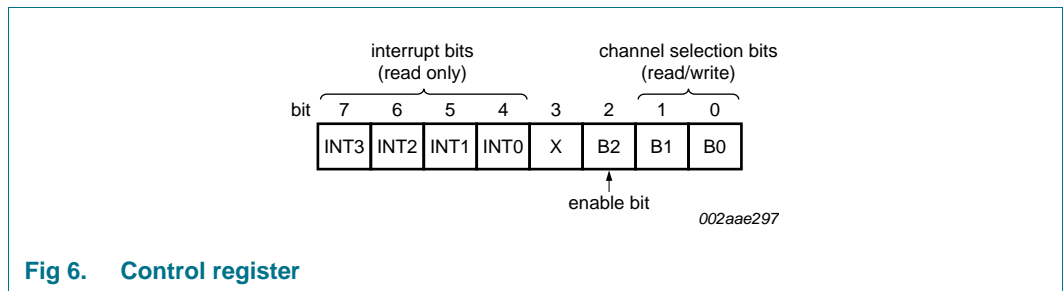

Fig 6. Control register

6.2.1 Control register definition

A SCx/SDx downstream pair, or channel, is selected by the contents of the control register. This register is written after the PCA9544A has been addressed. The 3 LSBs of the control byte are used to determine which channel is to be selected. When a channel is selected, it will become active after a STOP condition has been placed on the I²C-bus. This ensures that all SCx/SDx lines are in a HIGH state when the channel is made active, so that no false conditions are generated at the time of connection.

Table 4. Control register: Write — channel selection; Read — channel status

INT3	INT2	INT1	INT0	D3	B2	B1	B0	Command
X	X	X	X	X	0	X	X	no channel selected
X	X	X	X	X	1	0	0	channel 0 enabled
X	X	X	X	X	1	0	1	channel 1 enabled
X	X	X	X	X	1	1	0	channel 2 enabled
X	X	X	X	X	1	1	1	channel 3 enabled
0	0	0	0	0	0	0	0	no channel selected; power-up default state

6.3 Interrupt handling

The PCA9544A provides 4 interrupt inputs, one for each channel and one open-drain interrupt output. When an interrupt is generated by any device, it is detected by the PCA9544A and the interrupt output is driven LOW. The channel need not be active for detection of the interrupt. A bit is also set in the control byte. Bits 7:4 of the control byte correspond to channel 3 to channel 0 of the PCA9544A, respectively. Therefore, if an interrupt is generated by any device connected to channel 2, the state of the interrupt inputs is loaded into the control register when a read is accomplished. Likewise, an interrupt on any device connected to channel 0 would cause bit 4 of the control register to be set on the read. The master can then address the PCA9544A and read the contents of the control byte to determine which channel contains the device generating the interrupt. The master can then reconfigure the PCA9544A to select this channel, and locate the device generating the interrupt and clear it. The interrupt clears when the device originating the interrupt clears.

It should be noted that more than one device can be providing an interrupt on a channel, so it is up to the master to ensure that all devices on a channel are interrogated for an interrupt.

If the interrupt function is not required, the interrupt inputs may be used as general-purpose inputs.

If unused, interrupt inputs must be connected to V_{DD} through a pull-up resistor.

Table 5. Control register read — interrupt

INT3	INT2	INT1	INT0	D3	B2	B1	B0	Command
X	X	X	0	X	X	X	X	no interrupt on channel 0
			1					interrupt on channel 0
X	X	X	X	X	X	X	X	no interrupt on channel 1
								1
X	X	X	X	X	X	X	X	no interrupt on channel 2
								1
0	X	X	X	X	X	X	X	no interrupt on channel 3
								1

Remark: Several interrupts can be active at the same time. For example: INT3 = 0, INT2 = 1, INT1 = 1, INT0 = 0, means that there is no interrupt on channel 0 and channel 3, and there is an interrupt on channel 1 and on channel 2.

6.4 Power-on reset

When power is applied to V_{DD} , an internal Power-On Reset (POR) holds the PCA9544A in a reset condition until V_{DD} has reached V_{POR} . At this point, the reset condition is released and the PCA9544A registers and I²C-bus state machine are initialized to their default states (all zeroes), causing all the channels to be deselected. Thereafter, V_{DD} must be lowered below 0.2 V for at least 5 μ s in order to reset the device.

6.5 Voltage translation

The pass gate transistors of the PCA9544A are constructed such that the V_{DD} voltage can be used to limit the maximum voltage that is passed from one I²C-bus to another.

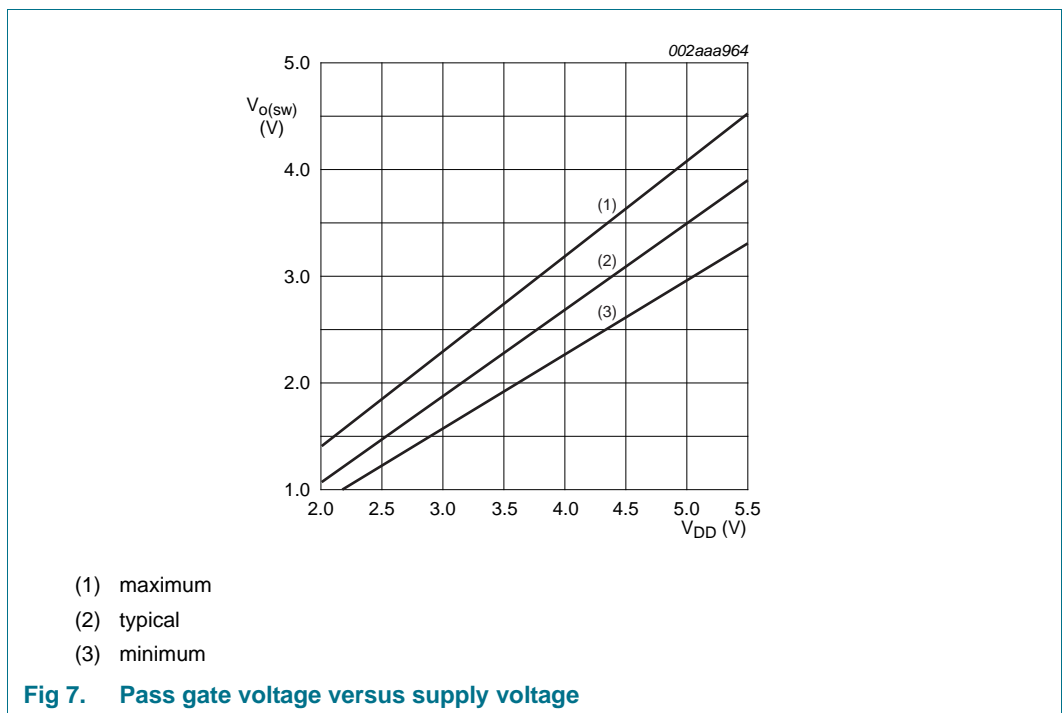

Figure 7 shows the voltage characteristics of the pass gate transistors (note that the graph was generated using the data specified in Section 12 “Dynamic characteristics” of this data sheet). In order for the PCA9544A to act as a voltage translator, the $V_{o(sw)}$ voltage should be equal to, or lower than the lowest bus voltage. For example, if the main bus was running at 5 V, and the downstream buses were 3.3 V and 2.7 V, then $V_{o(sw)}$ should be equal to or below 2.7 V to effectively clamp the downstream bus voltages. Looking at Figure 7, we see that $V_{o(sw)(max)}$ is at 2.7 V when the PCA9544A supply voltage is 3.5 V or lower so the PCA9544A supply voltage could be set to 3.3 V. Pull-up resistors can then be used to bring the bus voltages to their appropriate levels (see Figure 14).

More Information can be found in Application Note AN262, PCA954X family of I²C/SMBus multiplexers and switches.

7. Characteristics of the I²C-bus

The I²C-bus is for 2-way, 2-line communication between different ICs or modules. The two lines are a serial data line (SDA) and a serial clock line (SCL). Both lines must be connected to a positive supply via a pull-up resistor when connected to the output stages of a device. Data transfer may be initiated only when the bus is not busy.

7.1 Bit transfer

One data bit is transferred during each clock pulse. The data on the SDA line must remain stable during the HIGH period of the clock pulse as changes in the data line at this time will be interpreted as control signals (see [Figure 8](#)).

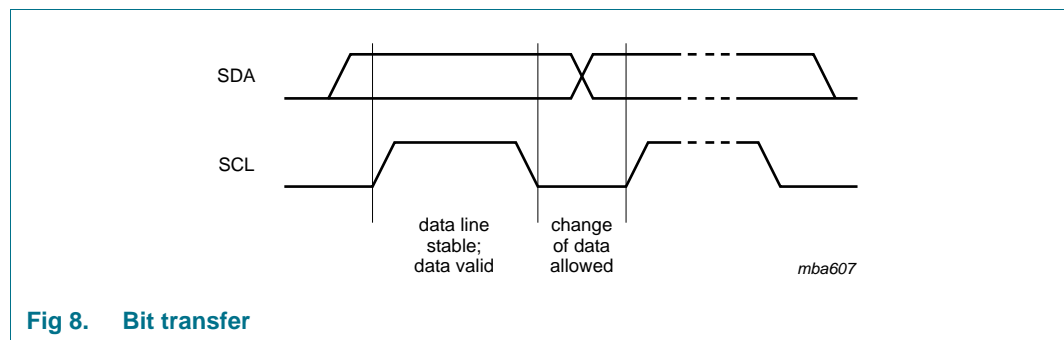

Fig 8. Bit transfer

7.2 START and STOP conditions

Both data and clock lines remain HIGH when the bus is not busy. A HIGH-to-LOW transition of the data line while the clock is HIGH is defined as the START condition (S). A LOW-to-HIGH transition of the data line while the clock is HIGH is defined as the STOP condition (P) (see [Figure 9](#)).

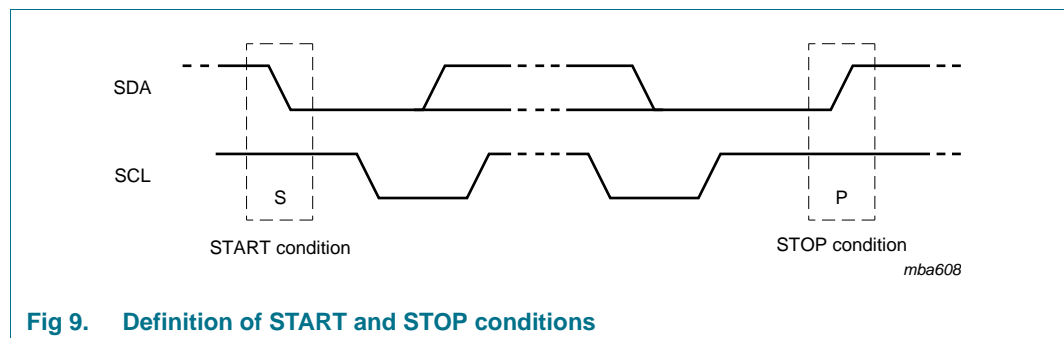

Fig 9. Definition of START and STOP conditions

7.3 System configuration

A device generating a message is a 'transmitter', a device receiving is the 'receiver'. The device that controls the message is the 'master' and the devices which are controlled by the master are the 'slaves' (see [Figure 10](#)).

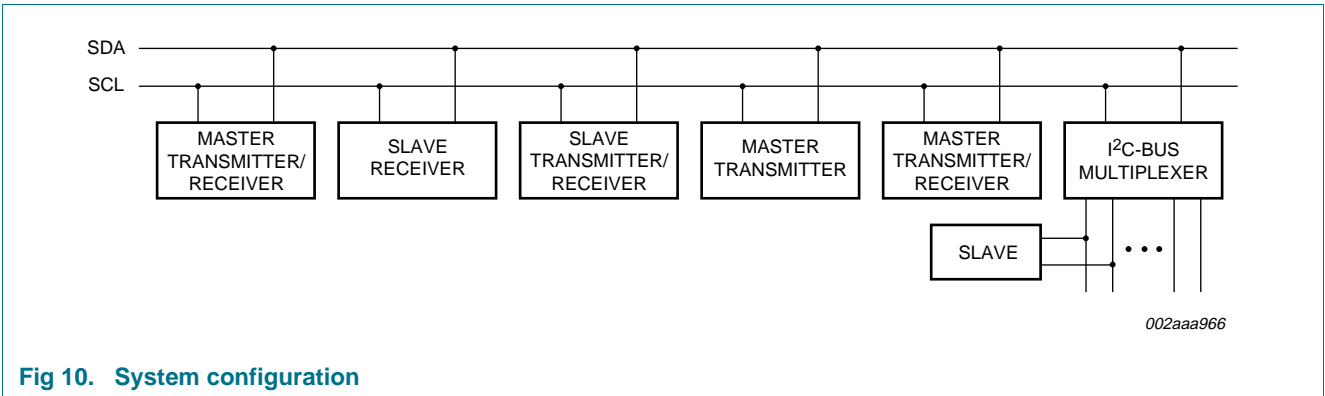

Fig 10. System configuration

7.4 Acknowledge

The number of data bytes transferred between the START and the STOP conditions from transmitter to receiver is not limited. Each byte of 8 bits is followed by one acknowledge bit. The acknowledge bit is a HIGH level put on the bus by the transmitter, whereas the master generates an extra acknowledge related clock pulse.

A slave receiver which is addressed must generate an acknowledge after the reception of each byte. Also, a master must generate an acknowledge after the reception of each byte that has been clocked out of the slave transmitter. The device that acknowledges has to pull down the SDA line during the acknowledge clock pulse so that the SDA line is stable LOW during the HIGH period of the acknowledge related clock pulse; set-up and hold times must be taken into account.

A master receiver must signal an end of data to the transmitter by not generating an acknowledge on the last byte that has been clocked out of the slave. In this event, the transmitter must leave the data line HIGH to enable the master to generate a STOP condition.

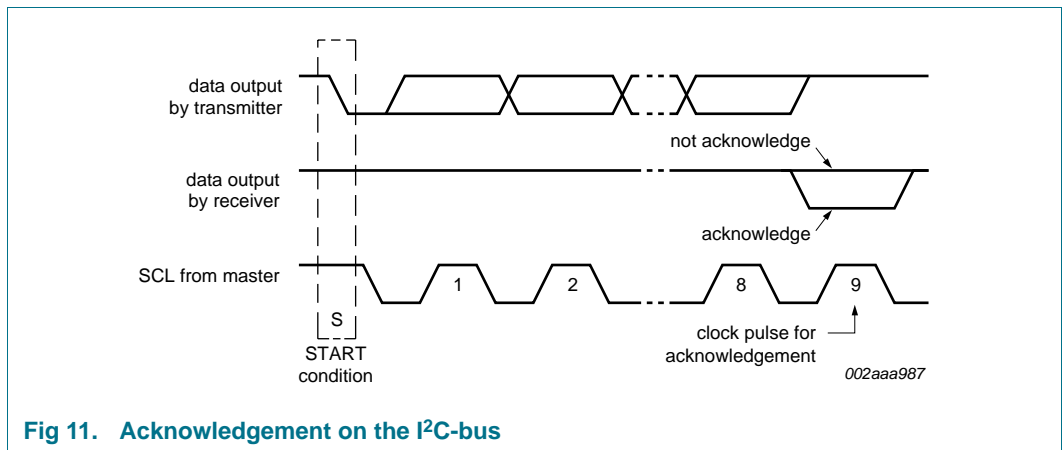
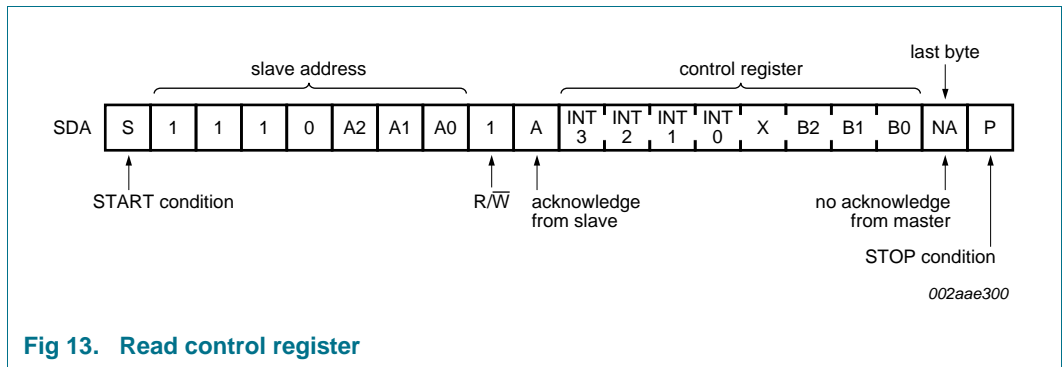
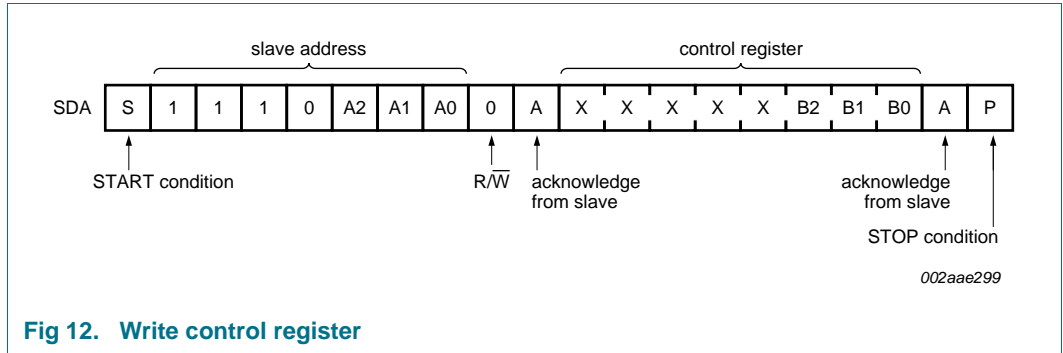

Fig 11. Acknowledgement on the I²C-bus

7.5 Bus transactions



9. Limiting values

Table 6. Limiting values

In accordance with the Absolute Maximum Rating System (IEC 60134).

Voltages are referenced to ground ($V_{SS} = 0$ V).^[1]

Symbol	Parameter	Conditions	Min	Max	Unit
V_{DD}	supply voltage		-0.5	+7.0	V
V_I	input voltage		-0.5	+7.0	V
I_I	input current		-	±20	mA
I_O	output current		-	±25	mA
I_{DD}	supply current		-	±100	mA
I_{SS}	ground supply current		-	±100	mA
P_{tot}	total power dissipation		-	400	mW
$T_{j(max)}$	maximum junction temperature	[1]	-	125	°C
T_{stg}	storage temperature		-60	+150	°C
T_{amb}	ambient temperature	operating	-40	+85	°C

[1] The performance capability of a high-performance integrated circuit in conjunction with its thermal environment can create junction temperatures which are detrimental to reliability. The maximum junction temperature of this integrated circuit should not exceed 125 °C.

10. Thermal characteristics

Table 7. Thermal characteristics

Symbol	Parameter	Conditions	Typ	Unit
$R_{th(j-a)}$	thermal resistance from junction to ambient	HVQFN20 package	32	°C/W
		SO20 package	90	°C/W
		TSSOP20 package	146	°C/W

11. Static characteristics

Table 8. Static characteristics at $V_{DD} = 2.3\text{ V}$ to 3.6 V

$V_{SS} = 0\text{ V}$; $T_{amb} = -40\text{ °C}$ to $+85\text{ °C}$; unless otherwise specified. See [Table 9](#) for $V_{DD} = 4.5\text{ V}$ to 5.5 V .^[1]

Symbol	Parameter	Conditions	Min	Typ	Max	Unit
Supply						
V_{DD}	supply voltage		2.3	-	3.6	V
I_{DD}	supply current	operating mode; $V_{DD} = 3.6\text{ V}$; no load; $V_I = V_{DD}$ or V_{SS} ; $f_{SCL} = 100\text{ kHz}$	-	10	30	μA
I_{stb}	standby current	standby mode; $V_{DD} = 3.6\text{ V}$; no load; $V_I = V_{DD}$ or V_{SS} ; $f_{SCL} = 0\text{ kHz}$	-	0.1	1	μA
V_{POR}	power-on reset voltage	no load; $V_I = V_{DD}$ or V_{SS}	[2]	1.5	2.1	V
Input SCL; input/output SDA						
V_{IL}	LOW-level input voltage		-0.5	-	+0.3 V_{DD}	V
V_{IH}	HIGH-level input voltage		0.7 V_{DD}	-	6	V
I_{OL}	LOW-level output current	$V_{OL} = 0.4\text{ V}$	3	7	-	mA
		$V_{OL} = 0.6\text{ V}$	6	10	-	mA
I_L	leakage current	$V_I = V_{DD}$ or V_{SS}	-1	-	+1	μA
C_i	input capacitance	$V_I = V_{SS}$	-	10	13	pF
Select inputs A0 to A2, INT0 to INT3						
V_{IL}	LOW-level input voltage		-0.5	-	+0.3 V_{DD}	V
V_{IH}	HIGH-level input voltage		0.7 V_{DD}	-	6	V
I_{LI}	input leakage current	$V_I = V_{DD}$ or V_{SS}	-1	-	+1	μA
C_i	input capacitance	$V_I = V_{SS}$	-	1.6	3	pF
Pass gate						
R_{on}	ON-state resistance	$V_{DD} = 3.0\text{ V}$ to 3.6 V ; $V_O = 0.4\text{ V}$; $I_O = 15\text{ mA}$	5	11	30	Ω
		$V_{DD} = 2.3\text{ V}$ to 2.7 V ; $V_O = 0.4\text{ V}$; $I_O = 10\text{ mA}$	7	16	55	Ω
$V_{o(sw)}$	switch output voltage	$V_{i(sw)} = V_{DD} = 3.3\text{ V}$; $I_{o(sw)} = -100\text{ }\mu\text{A}$	-	1.9	-	V
		$V_{i(sw)} = V_{DD} = 3.0\text{ V}$ to 3.6 V ; $I_{o(sw)} = -100\text{ }\mu\text{A}$	1.6	-	2.8	V
		$V_{i(sw)} = V_{DD} = 2.5\text{ V}$; $I_{o(sw)} = -100\text{ }\mu\text{A}$	-	1.5	-	V
		$V_{i(sw)} = V_{DD} = 2.3\text{ V}$ to 2.7 V ; $I_{o(sw)} = -100\text{ }\mu\text{A}$	1.1	-	2.0	V
I_L	leakage current	$V_I = V_{DD}$ or V_{SS}	-1	-	+1	μA
C_{io}	input/output capacitance	$V_I = V_{SS}$	-	3	5	pF
INT output						
I_{OL}	LOW-level output current	$V_{OL} = 0.4\text{ V}$	3	7	-	mA
I_{OH}	HIGH-level output current		-	-	+10	μA

[1] For operation between published voltage ranges, refer to worst case parameter in both ranges.

[2] In order to reset part, V_{DD} must be lowered to 0.2 V for at least $5\text{ }\mu\text{s}$.

Table 9. Static characteristics at V_{DD} = 4.5 V to 5.5 V

V_{SS} = 0 V; T_{amb} = -40 °C to +85 °C; unless otherwise specified. See [Table 8](#) for V_{DD} = 2.3 V to 3.6 V.^[1]

Symbol	Parameter	Conditions	Min	Typ	Max	Unit
Supply						
V _{DD}	supply voltage		4.5	-	5.5	V
I _{DD}	supply current	operating mode; V _{DD} = 5.5 V; no load; V _I = V _{DD} or V _{SS} ; f _{SCL} = 100 kHz	-	25	100	μA
I _{stb}	standby current	standby mode; V _{DD} = 5.5 V; no load; V _I = V _{DD} or V _{SS} ; f _{SCL} = 0 kHz	-	0.3	1	μA
V _{POR}	power-on reset voltage	no load; V _I = V _{DD} or V _{SS}	[2]	1.7	2.1	V
Input SCL; input/output SDA						
V _{IL}	LOW-level input voltage		-0.5	-	+0.3V _{DD}	V
V _{IH}	HIGH-level input voltage		0.7V _{DD}	-	6	V
I _{OL}	LOW-level output current	V _{OL} = 0.4 V	3	-	-	mA
		V _{OL} = 0.6 V	6	-	-	mA
I _L	leakage current	V _I = V _{DD} or V _{SS}	-1	-	+1	μA
C _i	input capacitance	V _I = V _{SS}	-	12	13	pF
Select inputs A0 to A2, INT0 to INT3						
V _{IL}	LOW-level input voltage		-0.5	-	+0.3V _{DD}	V
V _{IH}	HIGH-level input voltage		0.7V _{DD}	-	6	V
I _{LI}	input leakage current	pin at V _{DD} or V _{SS}	-1	-	+1	μA
C _i	input capacitance	V _I = V _{SS}	-	2	5	pF
Pass gate						
R _{on}	ON-state resistance	V _{DD} = 4.5 V to 5.5 V; V _O = 0.4 V; I _O = 15 mA	4	9	24	Ω
V _{o(sw)}	switch output voltage	V _{i(sw)} = V _{DD} = 5.0 V; I _{o(sw)} = -100 μA	-	3.6	-	V
		V _{i(sw)} = V _{DD} = 4.5 V to 5.5 V; I _{o(sw)} = -100 μA	2.6	-	4.5	V
I _L	leakage current	V _I = V _{DD} or V _{SS}	-1	-	+1	μA
C _{io}	input/output capacitance	V _I = V _{SS}	-	3	5	pF
INT output						
I _{OL}	LOW-level output current	V _{OL} = 0.4 V	3	-	-	mA
I _{OH}	HIGH-level output current		-	-	+10	μA

[1] For operation between published voltage ranges, refer to worst case parameter in both ranges.

[2] In order to reset part, V_{DD} must be lowered to 0.2 V for at least 5 μs.

12. Dynamic characteristics

Table 10. Dynamic characteristics

Symbol	Parameter	Conditions	Standard-mode I ² C-bus		Fast-mode I ² C-bus		Unit	
			Min	Max	Min	Max		
t _{PD}	propagation delay	from SDA to SDx, or SCL to SCx	-	0.3 ^[1]	-	0.3 ^[1]	ns	
f _{SCL}	SCL clock frequency		0	100	0	400	kHz	
t _{BUF}	bus free time between a STOP and START condition		4.7	-	1.3	-	μs	
t _{HD;STA}	hold time (repeated) START condition	^[2]	4.0	-	0.6	-	μs	
t _{LOW}	LOW period of the SCL clock		4.7	-	1.3	-	μs	
t _{HIGH}	HIGH period of the SCL clock		4.0	-	0.6	-	μs	
t _{SU;STA}	set-up time for a repeated START condition		4.7	-	0.6	-	μs	
t _{SU;STO}	set-up time for STOP condition		4.0	-	0.6	-	μs	
t _{HD;DAT}	data hold time		0 ^[3]	3.45	0 ^[3]	0.9	μs	
t _{SU;DAT}	data set-up time		250	-	100	-	ns	
t _r	rise time of both SDA and SCL signals		-	1000	20 + 0.1C _b ^[4]	300	ns	
t _f	fall time of both SDA and SCL signals		-	300	20 + 0.1C _b ^[4]	300	ns	
C _b	capacitive load for each bus line		-	400	-	400	pF	
t _{SP}	pulse width of spikes that must be suppressed by the input filter		-	50	-	50	ns	
t _{VD;DAT}	data valid time	HIGH-to-LOW	^[5]	-	1	-	1	μs
		LOW-to-HIGH	^[5]	-	0.6	-	0.6	μs
t _{VD;ACK}	data valid acknowledge time		-	1	-	1	μs	
INT								
t _{V(INTnN-INTN)}	valid time from $\overline{\text{INTn}}$ to $\overline{\text{INT}}$ signal	^[5]	-	4	-	4	μs	
t _{d(INTnN-INTN)}	delay time from $\overline{\text{INTn}}$ to $\overline{\text{INT}}$ inactive	^[5]	-	2	-	2	μs	
t _{w(rej)L}	LOW-level rejection time	$\overline{\text{INTn}}$ inputs	^[5]	1	-	1	μs	
t _{w(rej)H}	HIGH-level rejection time	$\overline{\text{INTn}}$ inputs	^[5]	0.5	-	0.5	μs	

[1] Pass gate propagation delay is calculated from the 20 Ω typical R_{on} and the 15 pF load capacitance.

[2] After this period, the first clock pulse is generated.

[3] A device must internally provide a hold time of at least 300 ns for the SDA signal (referred to the V_{IH(min)} of the SCL signal) in order to bridge the undefined region of the falling edge of SCL.

[4] C_b = total capacitance of one bus line in pF.

[5] Measurements taken with 1 kΩ pull-up resistor and 50 pF load.

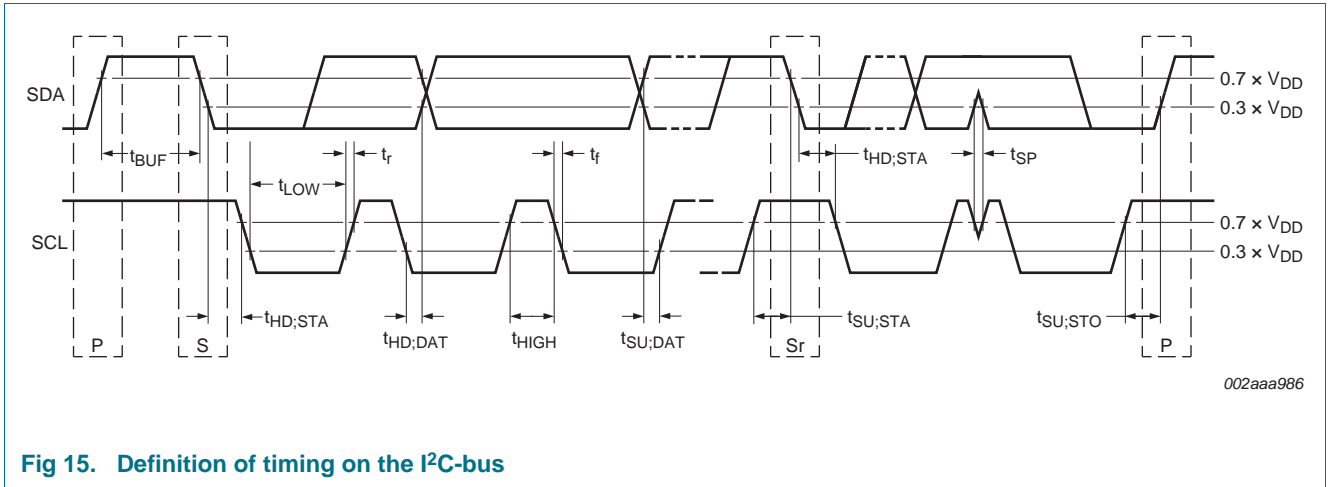

Fig 15. Definition of timing on the I²C-bus

13. Package outline

SO20: plastic small outline package; 20 leads; body width 7.5 mm

SOT163-1

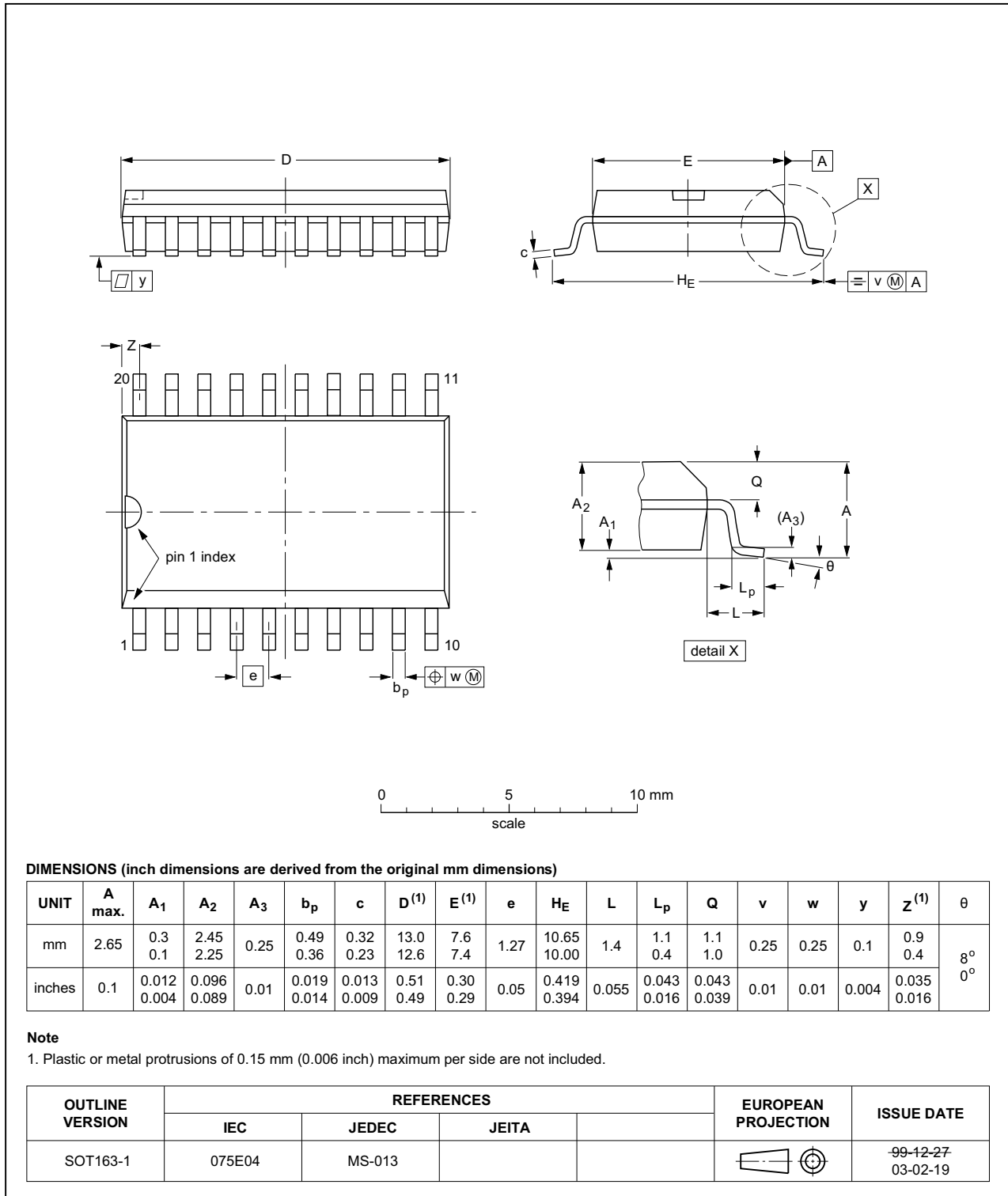

Fig 16. Package outline SOT163-1 (SO20)

TSSOP20: plastic thin shrink small outline package; 20 leads; body width 4.4 mm

SOT360-1

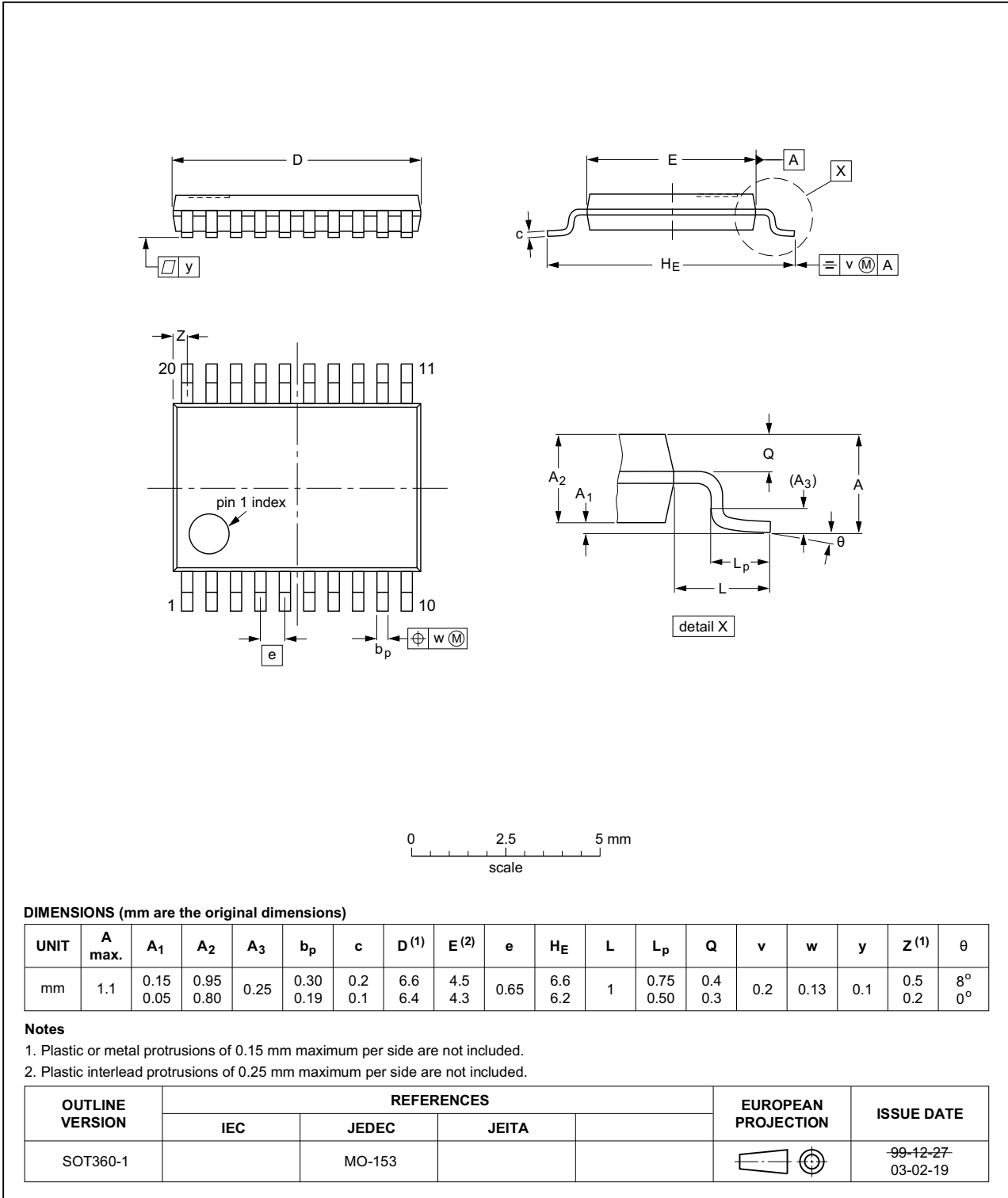

Fig 17. Package outline SOT360-1 (TSSOP20)

14. Soldering of SMD packages

This text provides a very brief insight into a complex technology. A more in-depth account of soldering ICs can be found in Application Note *AN10365 "Surface mount reflow soldering description"*.

14.1 Introduction to soldering

Soldering is one of the most common methods through which packages are attached to Printed Circuit Boards (PCBs), to form electrical circuits. The soldered joint provides both the mechanical and the electrical connection. There is no single soldering method that is ideal for all IC packages. Wave soldering is often preferred when through-hole and Surface Mount Devices (SMDs) are mixed on one printed wiring board; however, it is not suitable for fine pitch SMDs. Reflow soldering is ideal for the small pitches and high densities that come with increased miniaturization.

14.2 Wave and reflow soldering

Wave soldering is a joining technology in which the joints are made by solder coming from a standing wave of liquid solder. The wave soldering process is suitable for the following:

- Through-hole components
- Leaded or leadless SMDs, which are glued to the surface of the printed circuit board

Not all SMDs can be wave soldered. Packages with solder balls, and some leadless packages which have solder lands underneath the body, cannot be wave soldered. Also, leaded SMDs with leads having a pitch smaller than ~0.6 mm cannot be wave soldered, due to an increased probability of bridging.

The reflow soldering process involves applying solder paste to a board, followed by component placement and exposure to a temperature profile. Leaded packages, packages with solder balls, and leadless packages are all reflow solderable.

Key characteristics in both wave and reflow soldering are:

- Board specifications, including the board finish, solder masks and vias
- Package footprints, including solder thieves and orientation
- The moisture sensitivity level of the packages
- Package placement
- Inspection and repair
- Lead-free soldering versus SnPb soldering

14.3 Wave soldering

Key characteristics in wave soldering are:

- Process issues, such as application of adhesive and flux, clinching of leads, board transport, the solder wave parameters, and the time during which components are exposed to the wave
- Solder bath specifications, including temperature and impurities

14.4 Reflow soldering

Key characteristics in reflow soldering are:

- Lead-free versus SnPb soldering; note that a lead-free reflow process usually leads to higher minimum peak temperatures (see [Figure 19](#)) than a SnPb process, thus reducing the process window
- Solder paste printing issues including smearing, release, and adjusting the process window for a mix of large and small components on one board
- Reflow temperature profile; this profile includes preheat, reflow (in which the board is heated to the peak temperature) and cooling down. It is imperative that the peak temperature is high enough for the solder to make reliable solder joints (a solder paste characteristic). In addition, the peak temperature must be low enough that the packages and/or boards are not damaged. The peak temperature of the package depends on package thickness and volume and is classified in accordance with [Table 11](#) and [12](#)

Table 11. SnPb eutectic process (from J-STD-020D)

Package thickness (mm)	Package reflow temperature (°C)	
	Volume (mm ³)	
	< 350	≥ 350
< 2.5	235	220
≥ 2.5	220	220

Table 12. Lead-free process (from J-STD-020D)

Package thickness (mm)	Package reflow temperature (°C)		
	Volume (mm ³)		
	< 350	350 to 2000	> 2000
< 1.6	260	260	260
1.6 to 2.5	260	250	245
> 2.5	250	245	245

Moisture sensitivity precautions, as indicated on the packing, must be respected at all times.

Studies have shown that small packages reach higher temperatures during reflow soldering, see [Figure 19](#).

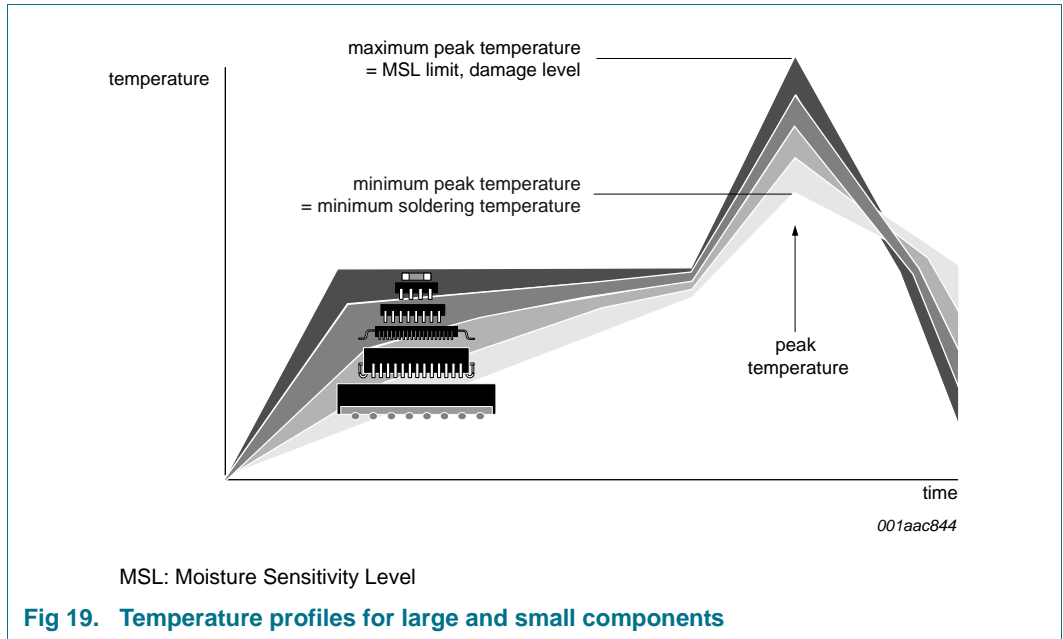

For further information on temperature profiles, refer to Application Note AN10365 “Surface mount reflow soldering description”.

15. Soldering: PCB footprints

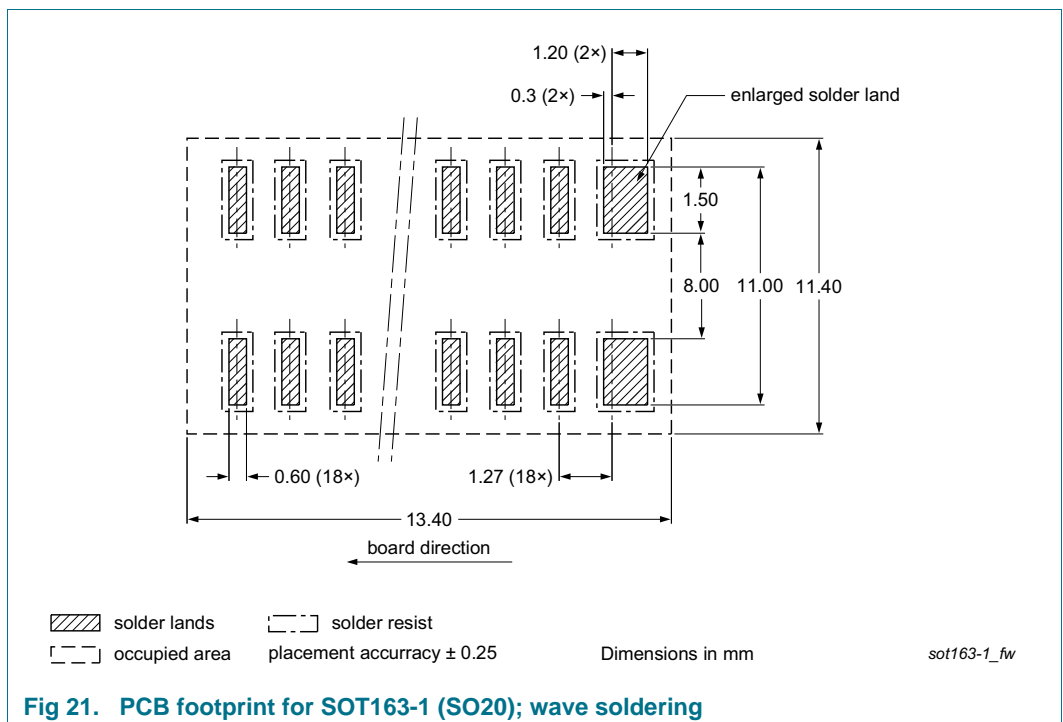
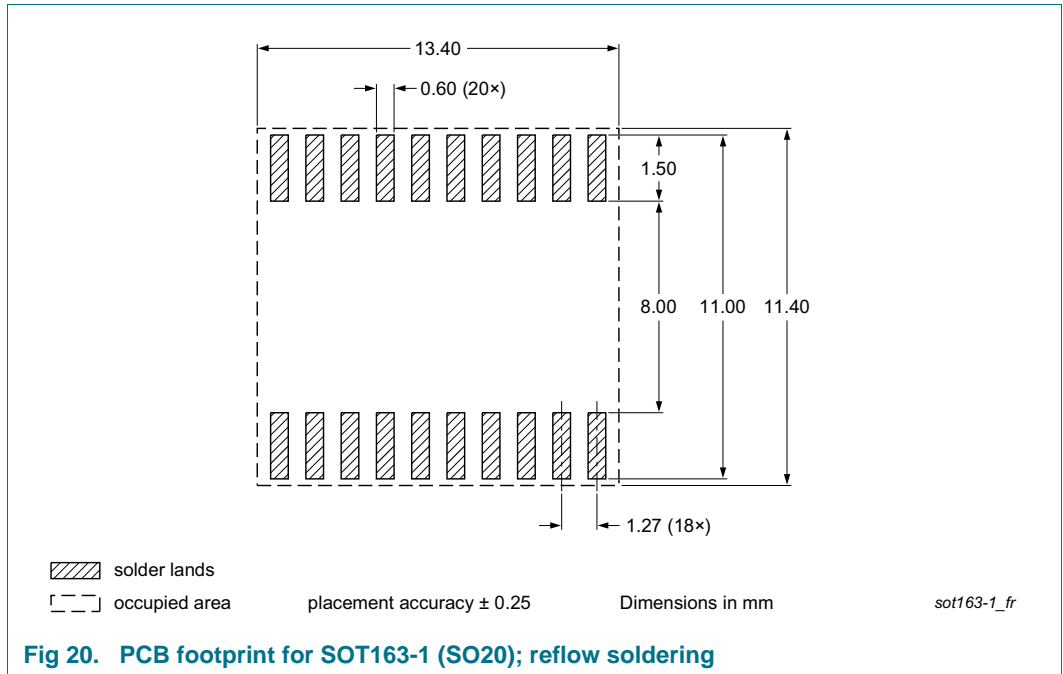

Footprint information for reflow soldering of TSSOP20 package

SOT360-1

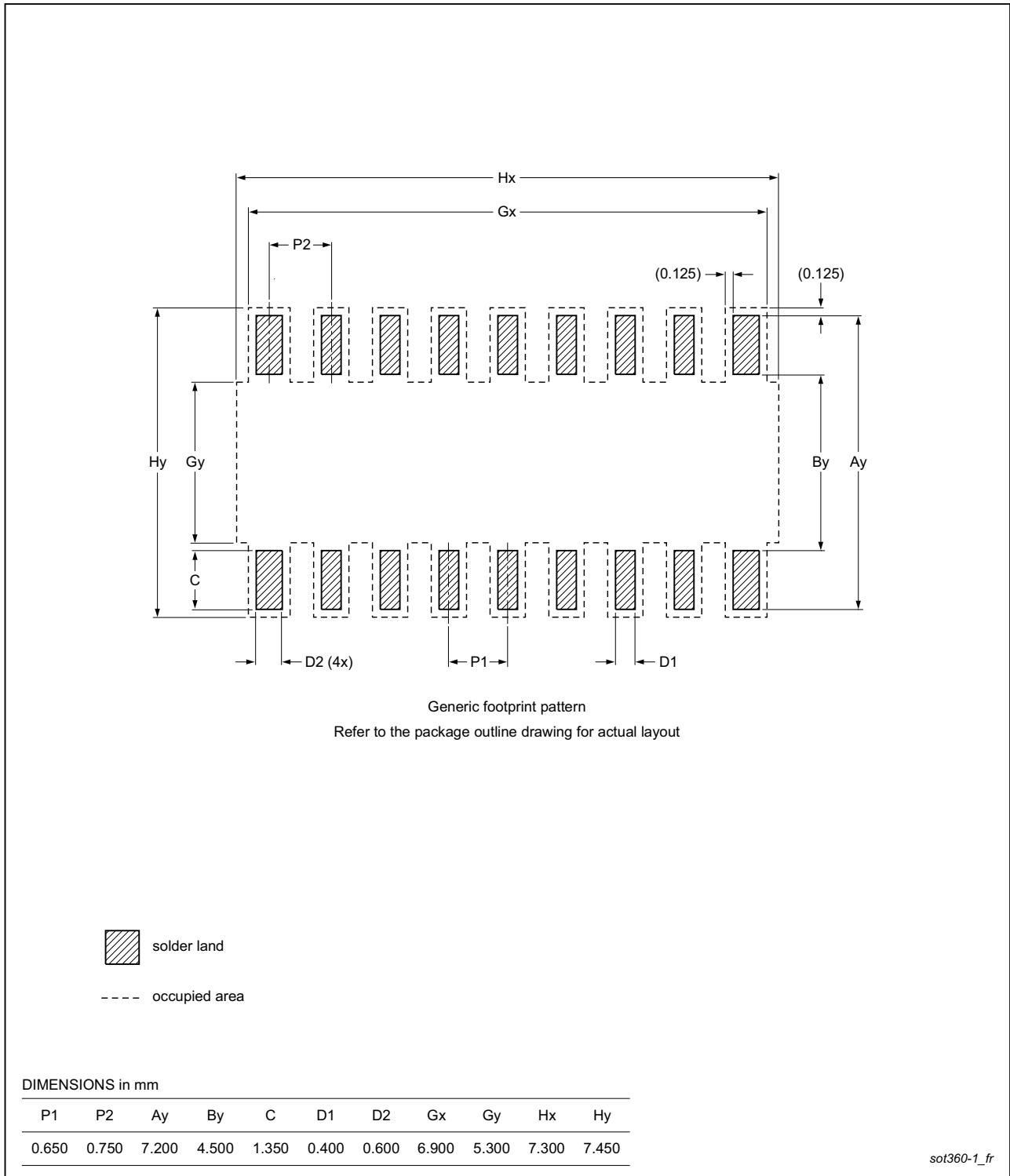

Fig 22. PCB footprint for SOT360-1 (TSSOP20); reflow soldering

Footprint information for reflow soldering of HVQFN20 package

SOT662-1

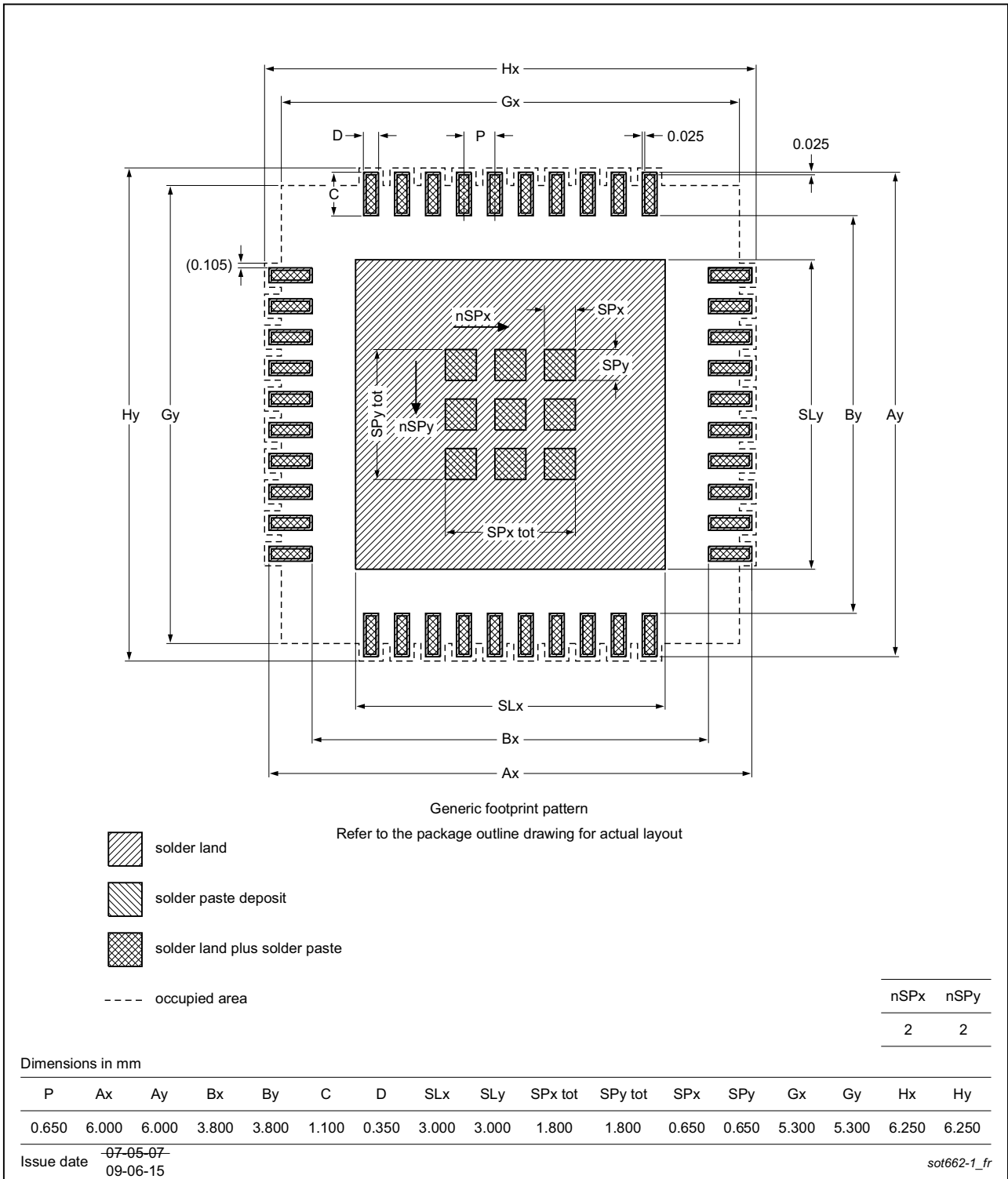

Fig 23. PCB footprint for SOT662-1 (HVQFN20); reflow soldering

16. Abbreviations

Table 13. Abbreviations

Acronym	Description
CDM	Charged-Device Model
ESD	ElectroStatic Discharge
HBM	Human Body Model
I/O	Input/Output
I ² C-bus	Inter-Integrated Circuit bus
LSB	Least Significant Bit
PCB	Printed-Circuit Board
POR	Power-On Reset
SMBus	System Management Bus

17. Revision history

Table 14. Revision history

Document ID	Release date	Data sheet status	Change notice	Supersedes
PCA9544A v.5	20140423	Product data sheet	-	PCA9544A v.4
Modifications:	<ul style="list-style-type: none"> • Section 2 “Features and benefits”, 16th bullet item: deleted phrase “200 V MM per JESD22-A115” • Table 1 “Ordering information”: added “Topside marking” column • Table 2 “Ordering options”: added “Orderable part number”, “Packing method”, and “Minimum order quantity” columns • Table 4 “Control register: Write — channel selection; Read — channel status”: value for INT0, command ‘channel 3 enabled’ corrected from “0” to “X” (correction to documentation only; no change to device) • Section 6.4 “Power-on reset”, first paragraph, third sentence: corrected from “V_{DD} must be lowered below 0.2 V to reset the device” to “In order to reset the device, V_{DD} must be lowered below 0.2 V for at least 5 μs.” (correction to documentation only; no change to device) • Table 6 “Limiting values”: added limiting value “T_{J(max)}” • Added (new) Section 10 “Thermal characteristics” • Table 8 “Static characteristics at V_{DD} = 2.3 V to 3.6 V”: <ul style="list-style-type: none"> – Table note [2]: inserted phrase “for at least 5 μs” – subsection “Select inputs A0 to A2, $\overline{\text{INT0}}$ to $\overline{\text{INT3}}$”: Max value for V_{IH} corrected from “V_{DD} + 0.5 V” to “6 V” (correction to documentation only; no change to device) • Table 9 “Static characteristics at V_{DD} = 4.5 V to 5.5 V”: <ul style="list-style-type: none"> – Table note [2]: inserted phrase “for at least 5 μs” – subsection “Select inputs A0 to A2, $\overline{\text{INT0}}$ to $\overline{\text{INT3}}$”: Max value for V_{IH} corrected from “V_{DD} + 0.5 V” to “6 V” (correction to documentation only; no change to device) • Figure 15 “Definition of timing on the I²C-bus” updated (added 0.3 × V_{DD} and 0.7 × V_{DD} reference lines) • Added Section 15 “Soldering: PCB footprints” 			
PCA9544A v.4	20090615	Product data sheet	-	PCA9544A v.3
PCA9544A v.3	20081124	Product data sheet	-	PCA9544A v.2
PCA9544A v.2 (9397 750 13931)	20040929	Product data sheet	-	PCA9544A v.1
PCA9544A v.1 (9397 750 13301)	20040728	Objective data sheet	-	-

18. Legal information

18.1 Data sheet status

Document status ^{[1][2]}	Product status ^[3]	Definition
Objective [short] data sheet	Development	This document contains data from the objective specification for product development.
Preliminary [short] data sheet	Qualification	This document contains data from the preliminary specification.
Product [short] data sheet	Production	This document contains the product specification.

[1] Please consult the most recently issued document before initiating or completing a design.

[2] The term 'short data sheet' is explained in section "Definitions".

[3] The product status of device(s) described in this document may have changed since this document was published and may differ in case of multiple devices. The latest product status information is available on the Internet at URL <http://www.nxp.com>.

18.2 Definitions

Draft — The document is a draft version only. The content is still under internal review and subject to formal approval, which may result in modifications or additions. NXP Semiconductors does not give any representations or warranties as to the accuracy or completeness of information included herein and shall have no liability for the consequences of use of such information.

Short data sheet — A short data sheet is an extract from a full data sheet with the same product type number(s) and title. A short data sheet is intended for quick reference only and should not be relied upon to contain detailed and full information. For detailed and full information see the relevant full data sheet, which is available on request via the local NXP Semiconductors sales office. In case of any inconsistency or conflict with the short data sheet, the full data sheet shall prevail.

Product specification — The information and data provided in a Product data sheet shall define the specification of the product as agreed between NXP Semiconductors and its customer, unless NXP Semiconductors and customer have explicitly agreed otherwise in writing. In no event however, shall an agreement be valid in which the NXP Semiconductors product is deemed to offer functions and qualities beyond those described in the Product data sheet.

18.3 Disclaimers

Limited warranty and liability — Information in this document is believed to be accurate and reliable. However, NXP Semiconductors does not give any representations or warranties, expressed or implied, as to the accuracy or completeness of such information and shall have no liability for the consequences of use of such information. NXP Semiconductors takes no responsibility for the content in this document if provided by an information source outside of NXP Semiconductors.

In no event shall NXP Semiconductors be liable for any indirect, incidental, punitive, special or consequential damages (including - without limitation - lost profits, lost savings, business interruption, costs related to the removal or replacement of any products or rework charges) whether or not such damages are based on tort (including negligence), warranty, breach of contract or any other legal theory.

Notwithstanding any damages that customer might incur for any reason whatsoever, NXP Semiconductors' aggregate and cumulative liability towards customer for the products described herein shall be limited in accordance with the *Terms and conditions of commercial sale* of NXP Semiconductors.

Right to make changes — NXP Semiconductors reserves the right to make changes to information published in this document, including without limitation specifications and product descriptions, at any time and without notice. This document supersedes and replaces all information supplied prior to the publication hereof.

Suitability for use — NXP Semiconductors products are not designed, authorized or warranted to be suitable for use in life support, life-critical or safety-critical systems or equipment, nor in applications where failure or malfunction of an NXP Semiconductors product can reasonably be expected to result in personal injury, death or severe property or environmental damage. NXP Semiconductors and its suppliers accept no liability for inclusion and/or use of NXP Semiconductors products in such equipment or applications and therefore such inclusion and/or use is at the customer's own risk.

Applications — Applications that are described herein for any of these products are for illustrative purposes only. NXP Semiconductors makes no representation or warranty that such applications will be suitable for the specified use without further testing or modification.

Customers are responsible for the design and operation of their applications and products using NXP Semiconductors products, and NXP Semiconductors accepts no liability for any assistance with applications or customer product design. It is customer's sole responsibility to determine whether the NXP Semiconductors product is suitable and fit for the customer's applications and products planned, as well as for the planned application and use of customer's third party customer(s). Customers should provide appropriate design and operating safeguards to minimize the risks associated with their applications and products.

NXP Semiconductors does not accept any liability related to any default, damage, costs or problem which is based on any weakness or default in the customer's applications or products, or the application or use by customer's third party customer(s). Customer is responsible for doing all necessary testing for the customer's applications and products using NXP Semiconductors products in order to avoid a default of the applications and the products or of the application or use by customer's third party customer(s). NXP does not accept any liability in this respect.

Limiting values — Stress above one or more limiting values (as defined in the Absolute Maximum Ratings System of IEC 60134) will cause permanent damage to the device. Limiting values are stress ratings only and (proper) operation of the device at these or any other conditions above those given in the Recommended operating conditions section (if present) or the Characteristics sections of this document is not warranted. Constant or repeated exposure to limiting values will permanently and irreversibly affect the quality and reliability of the device.

Terms and conditions of commercial sale — NXP Semiconductors products are sold subject to the general terms and conditions of commercial sale, as published at <http://www.nxp.com/profile/terms>, unless otherwise agreed in a valid written individual agreement. In case an individual agreement is concluded only the terms and conditions of the respective agreement shall apply. NXP Semiconductors hereby expressly objects to applying the customer's general terms and conditions with regard to the purchase of NXP Semiconductors products by customer.

No offer to sell or license — Nothing in this document may be interpreted or construed as an offer to sell products that is open for acceptance or the grant, conveyance or implication of any license under any copyrights, patents or other industrial or intellectual property rights.

4-channel I²C-bus multiplexer with interrupt logic

Export control — This document as well as the item(s) described herein may be subject to export control regulations. Export might require a prior authorization from competent authorities.

Non-automotive qualified products — Unless this data sheet expressly states that this specific NXP Semiconductors product is automotive qualified, the product is not suitable for automotive use. It is neither qualified nor tested in accordance with automotive testing or application requirements. NXP Semiconductors accepts no liability for inclusion and/or use of non-automotive qualified products in automotive equipment or applications.

In the event that customer uses the product for design-in and use in automotive applications to automotive specifications and standards, customer (a) shall use the product without NXP Semiconductors' warranty of the product for such automotive applications, use and specifications, and (b) whenever customer uses the product for automotive applications beyond NXP Semiconductors' specifications such use shall be solely at customer's

own risk, and (c) customer fully indemnifies NXP Semiconductors for any liability, damages or failed product claims resulting from customer design and use of the product for automotive applications beyond NXP Semiconductors' standard warranty and NXP Semiconductors' product specifications.

Translations — A non-English (translated) version of a document is for reference only. The English version shall prevail in case of any discrepancy between the translated and English versions.

18.4 Trademarks

Notice: All referenced brands, product names, service names and trademarks are the property of their respective owners.

I²C-bus — logo is a trademark of NXP Semiconductors N.V.

19. Contact information

For more information, please visit: <http://www.nxp.com>

For sales office addresses, please send an email to: salesaddresses@nxp.com

20. Contents

1	General description	1
2	Features and benefits	1
3	Ordering information	2
3.1	Ordering options	2
4	Block diagram	3
5	Pinning information	4
5.1	Pinning	4
5.2	Pin description	5
6	Functional description	6
6.1	Device addressing	6
6.2	Control register	6
6.2.1	Control register definition	6
6.3	Interrupt handling	7
6.4	Power-on reset	8
6.5	Voltage translation	8
7	Characteristics of the I²C-bus	9
7.1	Bit transfer	9
7.2	START and STOP conditions	9
7.3	System configuration	9
7.4	Acknowledge	10
7.5	Bus transactions	11
8	Application design-in information	12
9	Limiting values	13
10	Thermal characteristics	13
11	Static characteristics	14
12	Dynamic characteristics	16
13	Package outline	18
14	Soldering of SMD packages	21
14.1	Introduction to soldering	21
14.2	Wave and reflow soldering	21
14.3	Wave soldering	21
14.4	Reflow soldering	22
15	Soldering: PCB footprints	24
16	Abbreviations	27
17	Revision history	28
18	Legal information	29
18.1	Data sheet status	29
18.2	Definitions	29
18.3	Disclaimers	29
18.4	Trademarks	30
19	Contact information	30
20	Contents	31

Please be aware that important notices concerning this document and the product(s) described herein, have been included in section 'Legal information'.

© NXP Semiconductors N.V. 2014.

All rights reserved.

For more information, please visit: <http://www.nxp.com>

For sales office addresses, please send an email to: salesaddresses@nxp.com

Date of release: 23 April 2014

Document identifier: PCA9544A

Looking for pricing, stock, or lifecycle information?

Click below to explore more details on WIN SOURCE:

 [View PCA9544APW,112 on WIN SOURCE](#)

 [NXP / Nexperia Information](#)

Optimize Your Supply Chain with WIN SOURCE Solutions

-  Global Sourcing Solution
-  Obsolete Management
-  Cost Control Management
-  Shortage Management
-  Alternative Solution
-  Excess Inventory Management