



**THE DATASHEET OF
MT45W1MW16PDGA-70 IT**



Async/Page CellularRAM™ 1.0 Memory

MT45W1MW16PDGA

Features

- Asynchronous and page mode interface
- Random access time: 70ns
- VCC, VCCQ voltages
 - 1.7V–1.95V VCC
 - 1.7V–3.6V¹ VCCQ
- Page mode read access:
 - 16-word page size
 - Interpage read access: 70ns
 - Intrapage read access: 20ns
- Low power consumption:
 - Asynchronous READ: <20mA
 - Intrapage READ: <15mA
 - Standby: 70µA
 - Deep power-down: <10µA (TYP @ 25°C)
- Low-power features:
 - Temperature-compensated refresh (TCR)
 - On-chip temperature sensor
 - Partial-array refresh (PAR)
 - Deep power-down (DPD) mode

Options

- Configuration
 - 1 Meg x 16
- Package
 - 48-ball VFBGA (green)
- Access time
 - 70ns
- Operating temperature range
 - Wireless (–30°C to +85°C)¹
 - Industrial (–40°C to +85°C)²

Designator

MT45W1MW16PD
GA
–70
WT
IT

NOTE:

1. 3.6V I/O and –30°C exceed the CellularRAM Workgroup 1.0 specifications.
2. Contact factory for availability.

Figure 1: Ball Assignment – 48-Ball VFBGA

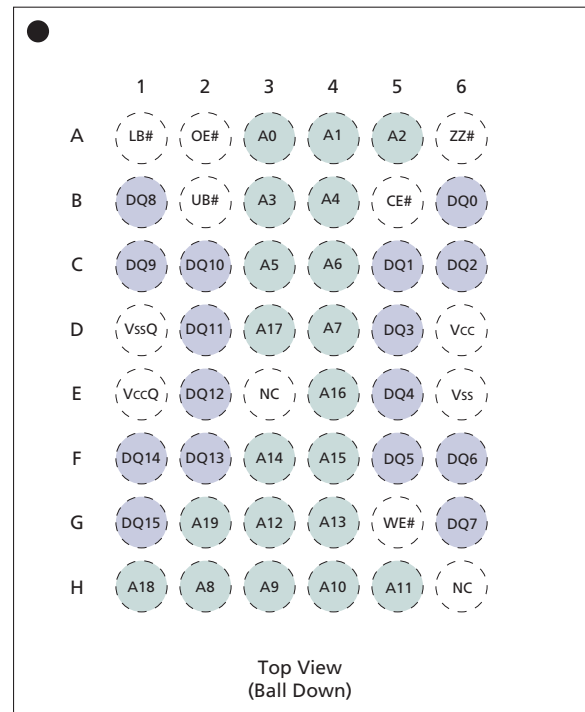

Part Number Example:

MT45W1MW16PDGA-70WT



Table of Contents

Features	1
General Description	5
Functional Block Diagram	5
Ball Descriptions	6
Bus Operations	7
Part Numbering Information	8
Valid Part Number Combinations	8
Device Marking	8
Functional Description	9
Power-Up Initialization	9
Bus Operating Modes	9
Asynchronous Mode	9
Page Mode READ Operation	11
LB#/UB# Operation	11
Low-Power Operation	12
Standby Mode Operation	12
Temperature-Compensated Refresh	12
Partial-Array Refresh	12
Deep Power-Down Operation	13
Configuration Register Operation	14
Access Using ZZ#	14
Software Access to the Configuration Register	14
Electrical Characteristics	18
Maximum and Typical Standby Currents	20
Timing Diagrams	24
Package Dimensions	28
Revision History	29



List of Figures

Figure 1:	Ball Assignment – 48-Ball VFBGA	1
Figure 2:	Functional Block Diagram – 1 Meg x 16	5
Figure 3:	Part Number Chart	8
Figure 4:	Power-Up Initialization Timing	9
Figure 5:	READ Operation	10
Figure 6:	WRITE Operation	10
Figure 7:	Page READ Operation	11
Figure 8:	Software Access PAR Functionality	13
Figure 9:	Load Configuration Register Operation	14
Figure 10:	Software Access Load Configuration Register	15
Figure 11:	Software Access Read Configuration Register	15
Figure 12:	Configuration Register Bit Mapping	16
Figure 13:	Typical Refresh Current vs. Temperature (ITCR)	20
Figure 14:	AC Input/Output Reference Waveform	21
Figure 15:	Output Load Circuit	21
Figure 16:	Power-Up Initialization Period	24
Figure 17:	Load Configuration Register	24
Figure 18:	Deep Power-Down – Entry/Exit	24
Figure 19:	Single READ Operation (WE# = VIH)	25
Figure 20:	Page Mode READ Operation (WE# = VIH)	25
Figure 21:	WRITE Cycle (WE# Control)	26
Figure 22:	WRITE Cycle (CE# Control)	26
Figure 23:	WRITE Cycle (LB#/UB# Control)	27
Figure 24:	48-Ball VFBGA	28

List of Tables

Table 1:	VFPGA Ball Descriptions	6
Table 2:	Bus Operations	7
Table 3:	16Mb Address Patterns for PAR (CR[4] = 1)	17
Table 4:	Absolute Maximum Ratings	18
Table 5:	Electrical Characteristics and Operating Conditions	19
Table 6:	Maximum Standby Currents for Applying PAR and TCR Settings	20
Table 7:	Deep Power-Down Specifications and Conditions	21
Table 8:	Capacitance Specifications and Conditions	21
Table 9:	READ Cycle Timing Requirements	22
Table 10:	WRITE Cycle Timing Requirements	23
Table 11:	Load Configuration Register Timing Requirements	23
Table 12:	Deep Power-Down Timing Requirements	23
Table 13:	Initialization Timing Parameters	24

General Description

Micron® CellularRAM™ products are high-speed, CMOS PSRAM memory devices developed for low-power, portable applications. The MT45W1MW16PD is a 16Mb DRAM core device organized as 1 Meg x 16 bits. These devices include the industry-standard, asynchronous memory interface found on other low-power SRAM or pseudo-SRAM offerings.

A user-accessible configuration register (CR) defines how the CellularRAM device performs on-chip refresh and whether page mode read accesses are permitted. This register is automatically loaded with a default setting during power-up and can be updated at any time during normal operation.

To operate seamlessly on an asynchronous memory bus, CellularRAM products incorporate a transparent self-refresh mechanism. The hidden refresh requires no additional support from the system memory controller and has no significant impact on device read/write performance.

Special attention has been focused on current consumption during self refresh. CellularRAM products include three system-accessible mechanisms to minimize refresh current. Temperature-compensated refresh (TCR) uses an on-chip sensor to adjust the refresh rate to match the device temperature. The refresh rate decreases at lower temperatures to minimize current consumption during standby. TCR can also be set by the system for maximum device temperatures of +85°C, +45°C, and +15°C. Setting sleep enable (ZZ#) to LOW enables one of two low-power modes: partial-array refresh (PAR) or deep power-down (DPD). PAR limits refresh to only that part of the DRAM array that contains essential data. DPD halts refresh operation altogether and is used when no vital information is stored in the device. These three refresh mechanisms are accessed through the CR.

Functional Block Diagram

Figure 2: Functional Block Diagram – 1 Meg x 16

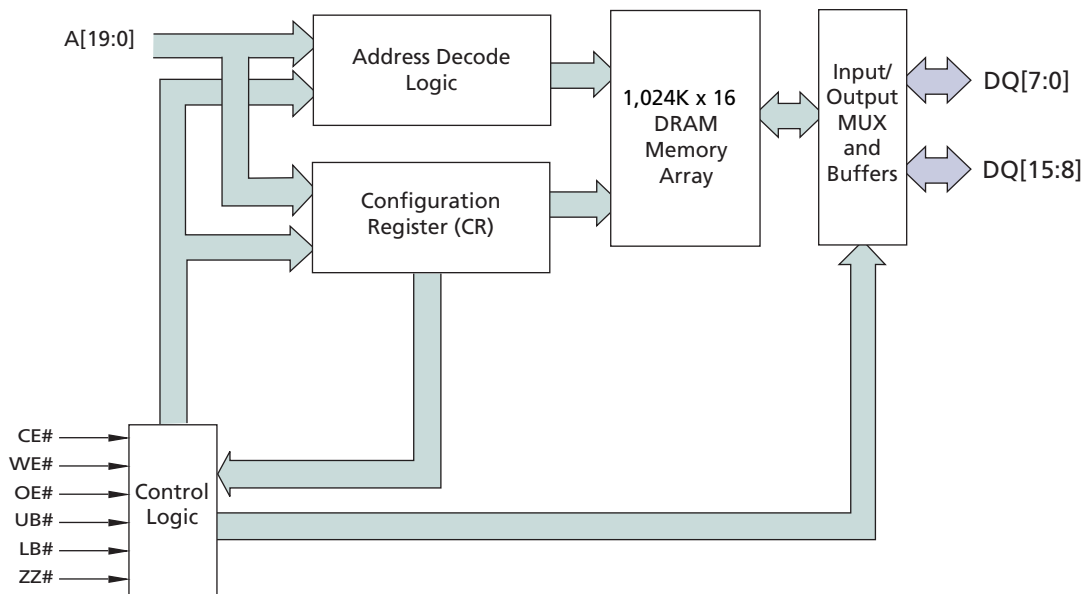

Note: Functional block diagrams illustrate simplified device operation. See truth table, ball descriptions, and timing diagrams for detailed information.

Ball Descriptions

Table 1: VFBGA Ball Descriptions

VFBGA Ball Assignment	Symbol	Type	Description
G2, H1, D3, E4, F4, F3, G4, G3, H5, H4, H3, H2, D4, C4, C3, B4, B3, A5, A4, A3	A[19:0]	Input	Address inputs: Inputs for the address accessed during READ or WRITE operations. The address lines are also used to define the value to be loaded into the CR.
A6	ZZ#	Input	Sleep enable: When ZZ# is LOW, the CR can be loaded or the device can enter one of two low-power modes (DPD or PAR).
B5	CE#	Input	Chip enable: Activates the device when LOW. When CE# is HIGH, the device is disabled and goes into standby power mode.
A2	OE#	Input	Output enable: Enables the output buffers when LOW. When OE# is HIGH, the output buffers are disabled.
G5	WE#	Input	Write enable: Enables WRITE operations when LOW.
A1	LB#	Input	Lower byte enable: DQ[7:0]
B2	UB#	Input	Upper byte enable: DQ[15:8]
G1, F1, F2, E2, D2, C2, C1, B1, G6, F6, F5, E5, D5, C6, C5, B6	DQ[15:0]	Input/ Output	Data inputs/outputs.
H6, E3	NC		Not internally connected.
D6	Vcc	Supply	Device power supply: (1.7V–1.95V) Power supply for device core operation.
E1	VccQ	Supply	I/O power supply: (1.7V–3.6V) Power supply for input/output buffers.
E6	Vss	Supply	Vss must be connected to ground.
D1	VssQ	Supply	VssQ must be connected to ground.

Bus Operations

Table 2: Bus Operations

Mode	Power	CE#	WE#	OE#	LB#/UB#	ZZ#	DQ[15:0] ¹	Notes
Standby	Standby	H	X	X	X	H	High-Z	2, 5
Read	Active	L	H	L	L	H	Data-out	1, 4
Write	Active	L	L	X	L	H	Data-in	1, 3, 4
No operation	Idle	L	X	X	X	H	X	4, 5
PAR	Partial-array refresh	H	X	X	X	L	High-Z	6
DPD	Deep power-down	H	X	X	X	L	High-Z	6
Load configuration register	Active	L	L	X	X	L	High-Z	

- Notes:
1. When LB# and UB# are in select mode (LOW), DQ[15:0] are affected. When LB# alone is in select mode, only DQ[7:0] are affected. When UB# alone is in the select mode, only DQ[15:8] are affected.
 2. When the device is in standby mode, control inputs (WE#, OE#), address inputs, and data inputs/outputs are internally isolated from any external influence.
 3. When WE# is active, the OE# input is internally disabled and has no effect on the I/Os.
 4. The device will consume active power in this mode whenever addresses are changed.
 5. $V_{IN} = V_{CCQ}$ or 0V; all device balls must be static (unswitched) in order to achieve minimum standby current.
 6. DPD is enabled when configuration register bit CR[4] is "0"; otherwise, PAR is enabled.

Part Numbering Information

Micron CellularRAM devices are available in several different configurations and densities (see Figure 3).

Figure 3: Part Number Chart

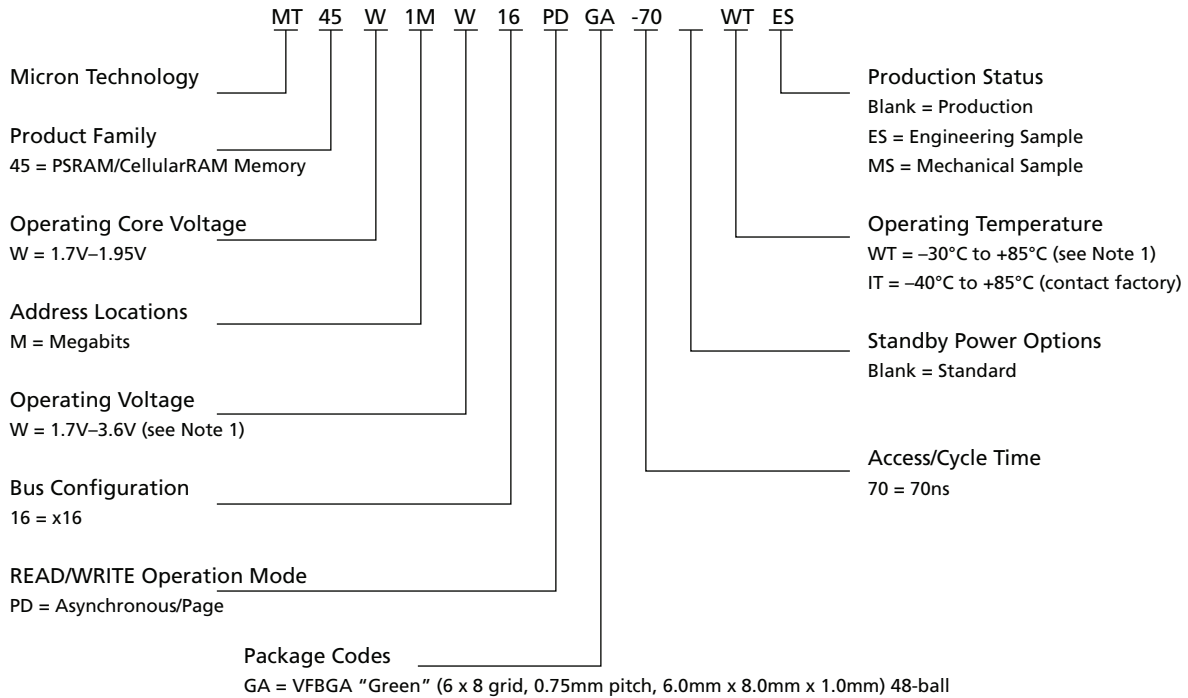

Notes: 1. 3.6V I/O and –30°C exceed the CellularRAM Workgroup 1.0 specifications.

Valid Part Number Combinations

After building the part number from the part numbering chart, please go to the Micron Part Marking Decoder Web site at <http://www.micron.com/partsearch> to verify that the part number is offered and valid. If the device required is not on this list, please contact the factory.

Device Marking

Due to the size of the package, the Micron standard part number is not printed on the device. Instead, an abbreviated device mark comprised of a five-digit alphanumeric code is used. The abbreviated device marks are cross-referenced to the Micron part numbers at <http://www.micron.com/partsearch>. To view the location of the abbreviated mark on the device, refer to customer service note, CSN-11, "Product Mark/Label," at <http://www.micron.com/csn>.

Functional Description

In general, the MT45W1MW16PD device is a high-density alternative to SRAM and Pseudo SRAM products, popular in low-power, portable applications. The MT45W1MW16PD contains a 16,777,216-bit DRAM core organized as 1,048,576 addresses by 16 bits. These devices include the industry-standard, asynchronous memory interface found on other low-power SRAM or Pseudo SRAM offerings. Page mode accesses are also included as a bandwidth-enhancing extension to the asynchronous read protocol.

Power-Up Initialization

CellularRAM products include an on-chip voltage sensor that is used to launch the power-up initialization process. Initialization will load the CR with its default setting. VCC and VCCQ must be applied simultaneously, and when they reach a stable level above 1.7V, the device will require 150µs to complete its self-initialization process (see Figure 4). During the initialization period, CE# should remain HIGH. When initialization is complete, the device is ready for normal operation.

Figure 4: Power-Up Initialization Timing

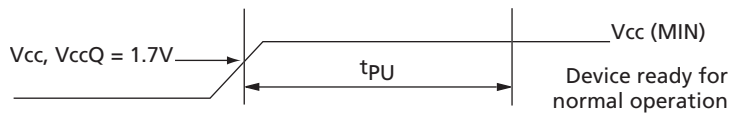

Bus Operating Modes

The MT45W1MW16PD CellularRAM product incorporates the industry-standard, asynchronous interface found on other low-power SRAM or Pseudo SRAM offerings. This bus interface supports asynchronous READ and WRITE operations as well as the bandwidth-enhancing page mode READ operation. The specific interface that is supported is defined by the value loaded into the CR.

Asynchronous Mode

CellularRAM products power up in the asynchronous operating mode. This mode uses the industry-standard SRAM control interface (CE#, OE#, WE#, LB#/UB#). READ operations (Figure 5) are initiated by bringing CE#, OE#, and LB#/UB# LOW while keeping WE# HIGH. Valid data will be driven out of the I/Os after the specified access time has elapsed. WRITE operations (Figure 6) occur when CE#, WE#, and LB#/UB# are driven LOW. During WRITE operations, the level of OE# is a "Don't Care"; WE# will override OE#. The data to be written will be latched on the rising edge of CE#, WE#, or LB#/UB# (whichever occurs first). WE# LOW time must be limited to t_{CEM} .

Figure 5: READ Operation

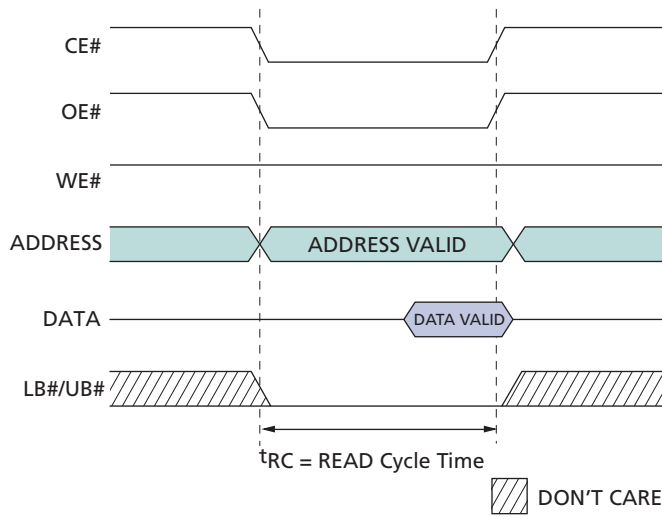
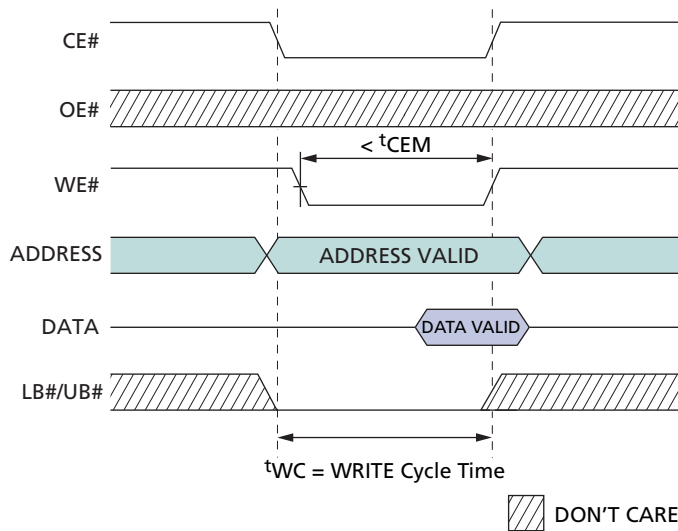

Figure 6: WRITE Operation



Page Mode READ Operation

Page mode is a performance-enhancing extension to the legacy asynchronous READ operation. In page-mode-capable products, an initial asynchronous read access is performed, then adjacent addresses can be quickly read by simply changing the low-order address. Addresses A[3:0] are used to determine the members of the 16-address CellularRAM page. Any change in addresses A[4] or higher will initiate a new t_{AA} access. Figure 7 shows the timing diagram for a page mode access.

Page mode takes advantage of the fact that adjacent addresses can be read in a shorter period of time than random addresses. WRITE operations do not include comparable page mode functionality.

The CE# LOW time is limited by refresh considerations. CE# must not stay LOW longer than t_{CEM} .

Figure 7: Page READ Operation

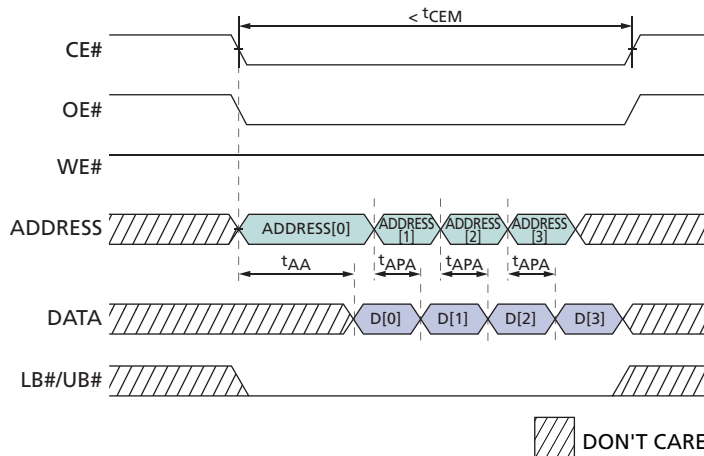

LB#/UB# Operation

The lower byte (LB#) enable and upper byte (UB#) enable signals allow for byte-wide data transfers. During READ operations, enabled bytes are driven onto the DQ. The DQ associated with a disabled byte are put into a High-Z state during a READ operation. During WRITE operations, any disabled bytes will not be transferred to the memory array and the internal value will remain unchanged. During a WRITE cycle, the data to be written is latched on the rising edge of CE#, WE#, LB#, or UB#, whichever occurs first. When both the LB# and UB# are disabled (HIGH) during an operation, the device will disable the data bus from receiving or transmitting data. Although the device will seem to be deselected, the device remains in an active mode as long as CE# remains LOW.

Low-Power Operation

Standby Mode Operation

During standby, the device current consumption is reduced to the level necessary to perform the DRAM refresh operation on the full array. Standby operation occurs when $CE\#$ and $ZZ\#$ are HIGH.

The device will enter a reduced power state during READ and WRITE operations where the address and control inputs remain static for an extended period of time. This mode will continue until a change occurs to the address or control inputs.

Temperature-Compensated Refresh

Temperature-compensated refresh (TCR) allows for adequate refresh at different temperatures. This CellularRAM device includes an on-chip temperature sensor. When the sensor is enabled, it continually adjusts the refresh rate according to the operating temperature. The on-chip sensor is enabled by default.

Three fixed refresh rates are also available, corresponding to temperature thresholds of +15°C, +45°C, and +85°C. The setting selected must be for a temperature higher than the case temperature of the CellularRAM device. If the case temperature is +35°C, the system can minimize self refresh current consumption by selecting the +45°C setting. Using the +15°C setting in the same environment would result in an inadequate refresh rate and cause data corruption.

Partial-Array Refresh

Partial-array refresh (PAR) restricts refresh operation to a portion of the total memory array. This feature enables the system to reduce refresh current by only refreshing that part of the memory array that is absolutely necessary. The refresh options are full array, one-half array, one-quarter array, one-eighth array, or none of the array. Data stored in addresses not receiving refresh will become corrupted. The mapping of these partitions can start at either the beginning or the end of the address map (Table 3 on page 17). READ and WRITE operations are ignored during PAR operation.

The device only enters PAR mode if the SLEEP bit in the CR has been set HIGH ($CR[4] = 1$). PAR can be initiated by bring the $ZZ\#$ ball to the LOW state for longer than 10 μ s. Returning $ZZ\#$ to HIGH will cause an exit from PAR and the entire array will be immediately available for READ and WRITE operations.

Alternatively, PAR can be initiated using the CR software access sequence (see “Software Access to the Configuration Register” on page 14). PAR is enabled immediately upon setting $CR[4]$ to “1” using this method. However, using software access to write to the CR alters the function of $ZZ\#$ so that $ZZ\#$ LOW no longer initiates PAR, although $ZZ\#$ continues to enable WRITES to the CR. This functional change persists until the next time the device is powered up (see Figure 8).

Figure 8: Software Access PAR Functionality

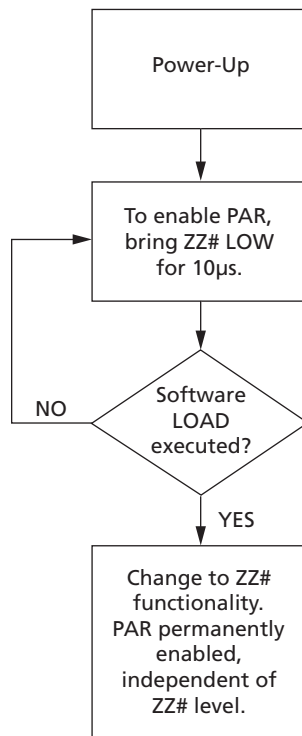

Deep Power-Down Operation

Deep power-down (DPD) operation disables all refresh-related activity. This mode is used when the system does not require the storage provided by the CellularRAM device. Any stored data will become corrupted when DPD is entered. When refresh activity has been re-enabled, the CellularRAM device will require 150µs to perform an initialization procedure before normal operations can resume. READ and WRITE operations are ignored during DPD operation.

The device can only enter DPD if the SLEEP bit in the CR has been set LOW (CR[4] = 0). DPD is initiated by bringing ZZ# to the LOW state for longer than 10µs. Returning ZZ# to HIGH will cause the device to exit DPD and begin a 150µs initialization process. During this 150µs period, the current consumption will be higher than the specified standby levels but considerably lower than the active current specification.

Driving ZZ# LOW will place the device in the PAR mode if the SLEEP bit in the CR has been set HIGH (CR[4] = 1).

The device should not be put into DPD using CR software access.

Configuration Register Operation

The configuration register (CR) defines how the CellularRAM device performs its transparent self refresh. Altering the refresh parameters can dramatically reduce current consumption during standby mode. Page mode control is also embedded into the CR. This register can be updated any time the device is operating in a standby state. Figure 12 on page 16 describes the control bits used in the CR. At power-up, the CR is set to 0010h.

Access Using ZZ#

The CR can be loaded using a WRITE operation immediately after ZZ# makes a HIGH-to-LOW transition (see Figure 9). The values placed on addresses A[19:0] are latched into the CR on the rising edge of CE# or WE#, whichever occurs first. LB#/UB# are “Don’t Care.” Access using ZZ# is WRITE only.

Figure 9: Load Configuration Register Operation

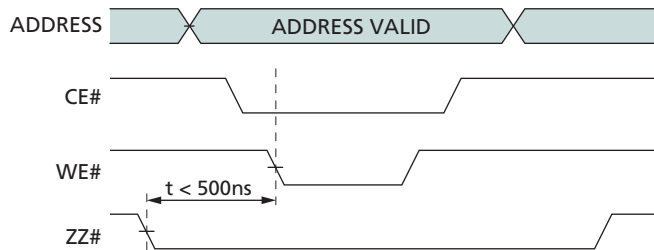

Software Access to the Configuration Register

The contents of the CR can either be read or modified using a software sequence. The nature of this access mechanism may eliminate the need for the ZZ# ball.

If the software mechanism is used, ZZ# can simply be tied to VCCQ. The port line typically used for ZZ# control purposes will no longer be required. However, ZZ# should not be tied to VCCQ if the system will use DPD; DPD cannot be enabled or disabled using the software access sequence.

The CR is loaded using a four-step sequence consisting of two READ operations followed by two WRITE operations (see Figure 10 on page 15). The read sequence is virtually identical except that an asynchronous READ is performed during the fourth operation (see Figure 11 on page 15). Note that a third READ cycle of the highest address will cancel the access sequence until a different address is read.

The address used during all READ and WRITE operations is the highest address of the CellularRAM device being accessed (FFFFFh for 16Mb); the content of this address is not changed by using this sequence. The data bus is used to transfer data into or out of bits 15–0 of the CR.

Writing to the CR using the software sequence modifies the function of the ZZ# ball. Once the software sequence loads the CR, the level of the ZZ# ball no longer enables PAR operation. PAR operation will be updated whenever the software sequence loads a new value into the CR. This ZZ# functionality will continue until the next time the device is powered-up. The operation of the ZZ# ball is not affected if the software sequence is only used to read the contents of the CR. The use of the software sequence does not affect the ability to perform the standard (ZZ#-controlled) method of loading the CR.

Figure 10: Software Access Load Configuration Register

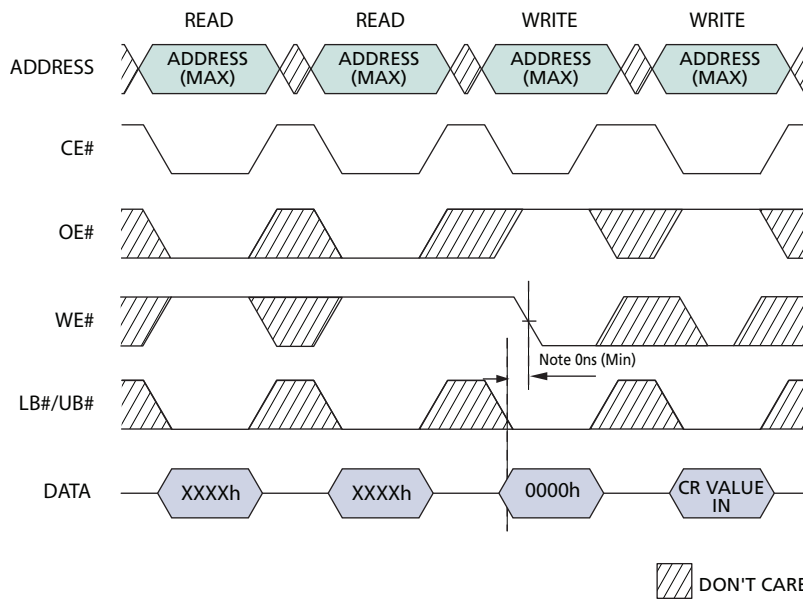

Note: If the data at the falling edge of WE# is not 0000h, it is possible that the data stored at the highest memory location will be altered.

Figure 11: Software Access Read Configuration Register

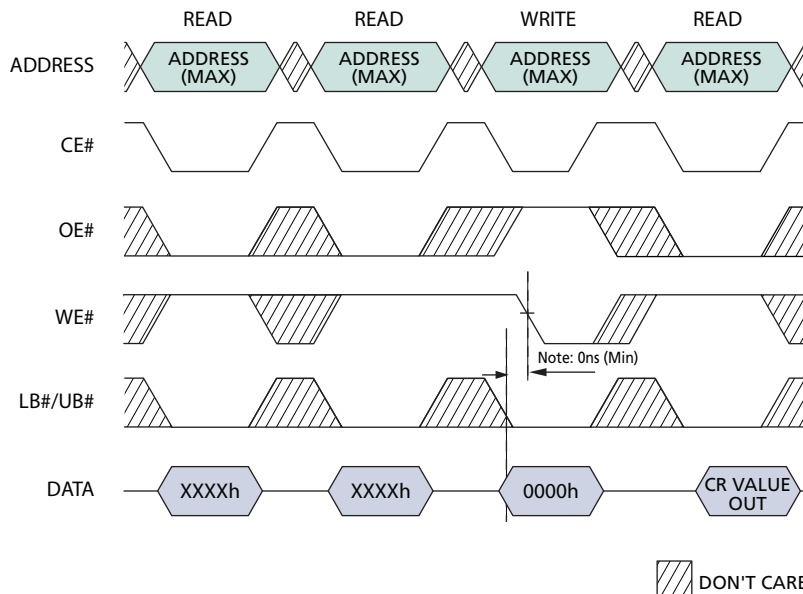

Note: If the data at the falling edge of WE# is not 0000h, it is possible that the data stored at the highest memory location will be altered.

Figure 12: Configuration Register Bit Mapping

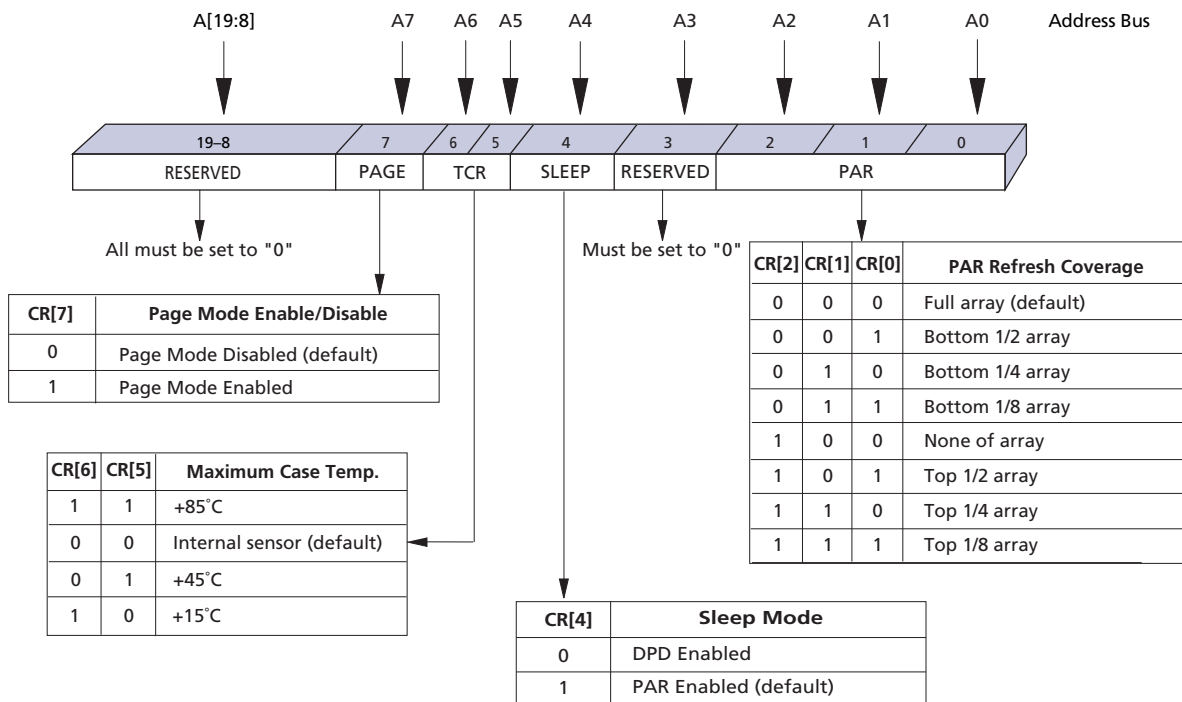

Partial-Array Refresh (CR[2:0]) Default = Full-Array Refresh

The PAR bits restrict refresh operation to a portion of the total memory array. This feature allows the system to reduce current by only refreshing that part of the memory array required by the host system. The refresh options are full array, one-half array, one-quarter array, one-eighth array, or none of the array. The mapping of these partitions can start at either the beginning or the end of the address map (see Table 3 on page 17).

Sleep Mode (CR[4]) Default = PAR Enabled, DPD Disabled

The sleep mode bit determines which low-power mode is to be entered when ZZ# is driven LOW. If CR[4] = 1, PAR operation is enabled. If CR[4] = 0, DPD operation is enabled. PAR can also be enabled directly by writing to the CR using the software access sequence. Note that this then disables ZZ# initiation of PAR. DPD cannot be enabled or disabled using the software access sequence; this should only be done using ZZ# to access the CR.

DPD operation disables all refresh-related activity. This mode will be used when the system does not require the storage provided by the CellularRAM device. Any stored data will become corrupted when DPD is enabled. When refresh activity has been re-enabled, the CellularRAM device will require 150µs to perform an initialization procedure before normal operation can resume. DPD should not be enabled using CR software access.

Temperature-Compensated Refresh (CR[6:5]) Default = On-Chip Temperature Sensor

This CellularRAM device includes an on-chip temperature sensor that automatically adjusts the refresh rate according to the operating temperature. The on-chip TCR is enabled by clearing both of the TCR bits in the refresh configuration register (CR[6:5] = 00b). Any other TCR setting enables a fixed refresh rate. When the on-chip temperature sensor is enabled, the device continually adjusts the refresh rate according to the operating temperature.



16Mb: 1 Meg x 16 Async/Page CellularRAM 1.0 Memory Configuration Register Operation

The TCR bits also allow for adequate fixed-rate refresh at three different temperature thresholds (+15°C, +45°C, and +85°C). The setting selected must be for a temperature higher than the case temperature of the CellularRAM device. If the case temperature is +35°C, the system can minimize self refresh current consumption by selecting the +45°C setting. Using the +15°C setting in the same environment would result in an inadequate refresh rate and cause data corruption.

Page Mode READ Operation (CR[7]) Default = Disabled

The page mode operation bit determines whether page mode READ operations are enabled. In the power-up default state, page mode is disabled.

Table 3: 16Mb Address Patterns for PAR (CR[4] = 1)

CR[2]	CR[1]	CR[0]	Active Section	Address Space	Size	Density
0	0	0	Full die	00000h–FFFFFh	1 Meg x 16	16Mb
0	0	1	One-half of die	00000h–7FFFFh	512K x 16	8Mb
0	1	0	One-quarter of die	00000h–3FFFFh	256K x 16	4Mb
0	1	1	One-eighth of die	00000h–1FFFFh	128K x 16	2Mb
1	0	0	None of die	0	0 Meg x 16	0Mb
1	0	1	One-half of die	80000h–FFFFFh	512K x 16	8Mb
1	1	0	One-quarter of die	C0000h–FFFFFh	256K x 16	4Mb
1	1	1	One-eighth of die	E0000h–FFFFFh	128K x 16	2Mb

Electrical Characteristics

Stresses greater than those listed in Table 4 may cause permanent damage to the device. This is a stress rating only, and functional operation of the device at these or any other conditions above those indicated in the operational sections of this specification is not implied. Exposure to absolute maximum rating conditions for extended periods may affect reliability.

Table 4: Absolute Maximum Ratings

Parameter	Rating
Voltage to any ball except VCC, VCCQ relative to VSS	-0.5V to (4.0V or VCCQ + 0.3V, whichever is less)
Voltage on VCC supply relative to VSS	-0.2V to 2.45V
Voltage on VCCQ supply relative to VSS	-0.2V to 4.0V
Storage temperature	-55°C to 150°C
Operating temperature (case)	
Wireless ¹	-30°C to 85°C
Industrial	-40°C to 85°C
Soldering temperature and time 10 seconds (solder ball only)	260°C

Notes: 1. -30°C exceeds the CellularRAM Workgroup 1.0 specification of -25°C.

Table 5: Electrical Characteristics and Operating Conditions

Wireless temperature¹ ($-30^{\circ}\text{C} \leq T_C \leq +85^{\circ}\text{C}$), Industrial temperature ($-40^{\circ}\text{C} < T_C < +85^{\circ}\text{C}$)

Description	Conditions	Symbol		Min	Max	Units	Notes
Supply voltage		V _{CC}		1.7	1.95	V	
I/O supply voltage		V _{CCQ}		1.7	3.6	V	1
Input high voltage		V _{IH}		1.4	V _{CCQ} + 0.2	V	2, 3
Input low voltage		V _{IL}		-0.2	+0.4	V	4
Output high voltage	I _{OH} = -0.2mA	V _{OH}		0.8 V _{CCQ}		V	
Output low voltage	I _{OL} = 0.2mA	V _{OL}			0.2 V _{CCQ}	V	
Input leakage current	V _{IN} = 0 to V _{CCQ}	I _{LI}			1	μA	
Output leakage current	OE# = V _{IH} or Chip Disabled	I _{LO}			1	μA	
Operating Current							
Asynchronous random READ/WRITE	V _{IN} = V _{CCQ} or 0V Chip Enabled, I _{OUT} = 0	I _{CC1}	-70		20	mA	5
Asynchronous page READ		I _{CC1P}	-70		15	mA	5
Standby current	V _{IN} = V _{CCQ} or 0V CE# = V _{CCQ}	I _{SB}			70	μA	6

- Notes:
1. -30°C and 3.6V I/O exceed the CellularRAM Workgroup 1.0 specifications.
 2. Input signals may overshoot to V_{CCQ} + 1.0V for periods less than 2ns during transitions.
 3. V_{IH} (MIN) value is not aligned with CellularRAM Workgroup 1.0 specification of V_{CCQ} - 0.4V.
 4. Input signals may undershoot to V_{SS} - 1.0V for periods less than 2ns during transitions.
 5. This parameter is specified with the outputs disabled to avoid external loading effects. The user must add the current required to drive output capacitance expected in the actual system.
 6. I_{SB} (MAX) values measured with PAR set to FULL ARRAY and TCR set to $+85^{\circ}\text{C}$. In order to achieve low standby current, all inputs must be driven to V_{CCQ} or V_{SS}. I_{SB} may be slightly higher for up to 500ms after power-up or when entering standby mode.

Maximum and Typical Standby Currents

Table 6 and Figure 13 refer to the maximum and typical standby currents for the MT45W1MW16PD device. The typical values shown in Figure 13 are measured with the default on-chip temperature sensor control enabled. The maximum values shown in Table 6 are measured with the relevant TCR bits set in the configuration register.

Table 6: Maximum Standby Currents for Applying PAR and TCR Settings

PAR	TCR		
	+15°C (CR[6:5] = 10b)	+45°C (CR[6:5] = 01b)	+85°C (CR[6:5] = 11b)
Full array	45	60	70
1/2 array	40	55	65
1/4 array	37	50	60
1/8 array	37	50	60
0 array	35	45	55

- Notes:
1. For CR[6:5] = 00b (default), refer to Figure 13 for typical values.
 2. In order to achieve low standby current, all inputs must be driven to VccQ or Vss. I_{SB} may be slightly higher for up to 500ms after power-up or when entering standby mode.
 3. TCR values for 85°C are 100 percent tested. TCR values for 15°C and 45°C are sampled only.

Figure 13: Typical Refresh Current vs. Temperature (I_{TCR})

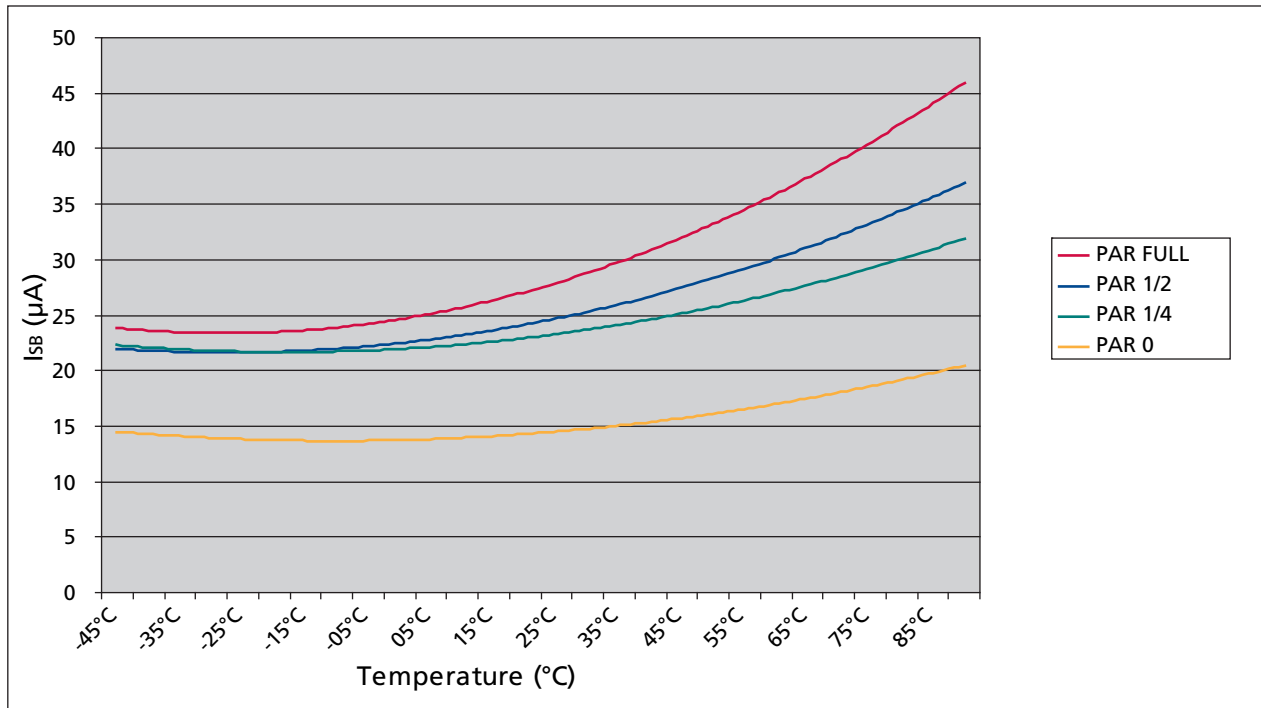

Note: Typical I_{SB} currents for each PAR setting with the appropriate TCR selected, or temperature sensor enabled.

Table 7: Deep Power-Down Specifications and Conditions

Description	Conditions	Symbol	TYP	Units
Deep power-down	$V_{IN} = V_{CCQ}$ or $0V$; $+25^{\circ}C$ $ZZ\# = 0V$ $CR[4] = 0$	I_{ZZ}	10	μA

Table 8: Capacitance Specifications and Conditions

Description	Conditions	Symbol	Min	Max	Units	Notes
Input capacitance	$T_C = +25^{\circ}C$; $f = 1$ MHz; $V_{IN} = 0V$	C_{IN}	2.0	6.5	pF	1
Input/output capacitance (DQ)		C_{IO}	3.0	6.5	pF	1

Notes: 1. These parameters are verified in device characterization and are not 100 percent tested.

Figure 14: AC Input/Output Reference Waveform

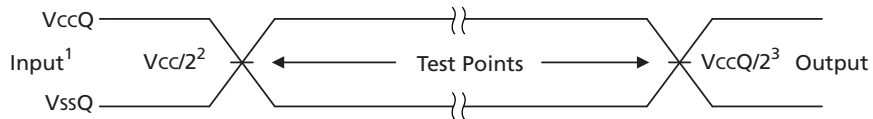

- Notes: 1. AC test inputs are driven at V_{CCQ} for a logic 1 and V_{SSQ} for a logic 0. Input rise and fall times (10% to 90%) $< 1.6ns$.
 2. Input timing begins at $V_{CC}/2$. Due to the possibility of a difference between V_{CC} and V_{CCQ} , the input test point may not be shown to scale.
 3. Output timing ends at $V_{CCQ}/2$.

Figure 15: Output Load Circuit

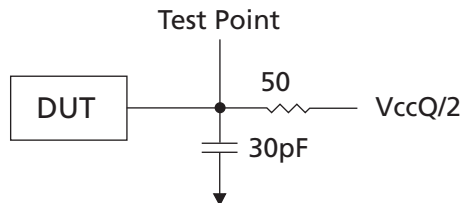

Table 9: READ Cycle Timing Requirements

Parameter	Symbol	-70		Units	Notes
		Min	Max		
Address access time	t_{AA}		70	ns	
Page access time	t_{APA}		20	ns	
LB#/UB# access time	t_{BA}		70	ns	
LB#/UB# disable to High-Z output	t_{BHZ}		8	ns	2
LB#/UB# enable to Low-Z output	t_{BLZ}	10		ns	1
Maximum CE# pulse width	t_{CEM}		8	μ s	3
Chip select access time	t_{CO}		70	ns	
Chip disable to High-Z output	t_{HZ}		8	ns	2
Chip enable to Low-Z output	t_{LZ}	10		ns	1
Output enable to valid output	t_{OE}		20	ns	
Output hold from address change	t_{OH}	5		ns	
Output disable to High-Z output	t_{OHZ}		8	ns	2
Output enable to Low-Z output	t_{OLZ}	5		ns	1
Page cycle time	t_{PC}	20		ns	
Read cycle time	t_{RC}	70		ns	

- Notes:
1. High-Z to Low-Z timings are tested with the circuit shown in Figure 15 on page 21. The Low-Z timings measure a 100mV transition away from the High-Z ($V_{CCQ/2}$) level toward either V_{OH} or V_{OL} .
 2. Low-Z to High-Z timings are tested with the circuit shown in Figure 15 on page 21. The High-Z timings measure a 100mV transition from either V_{OH} or V_{OL} toward $V_{CCQ/2}$.
 3. Page mode enabled only.

Table 10: WRITE Cycle Timing Requirements

Parameter	Symbol	-70		Units	Notes
		Min	Max		
Address setup time	t_{AS}	0		ns	
Address valid to end of write	t_{AW}	70		ns	
Byte select to end of write	t_{BW}	70		ns	
CE# HIGH time during write	t_{CPH}	5		ns	
Chip enable to end of write	t_{CW}	70		ns	
Data hold from write time	t_{DH}	0		ns	
Data write setup time	t_{DW}	23		ns	
Chip enable to Low-Z output	t_{LZ}	10		ns	1
End write to Low-Z output	t_{OW}	5		ns	1
WRITE cycle time	t_{WC}	70		ns	
WRITE to High-Z output	t_{WHZ}		8	ns	2
WRITE pulse width	t_{WP}	46		ns	3
WRITE pulse width HIGH	t_{WPH}	10		ns	
WRITE recovery time	t_{WR}	0		ns	

- Notes:
1. High-Z to Low-Z timings are tested with the circuit shown in Figure 15 on page 21. The Low-Z timings measure a 100mV transition away from the High-Z ($V_{CCQ/2}$) level toward either V_{OH} or V_{OL} .
 2. Low-Z to High-Z timings are tested with the circuit shown in Figure 15 on page 21. The High-Z timings measure a 100mV transition from either V_{OH} or V_{OL} toward $V_{CCQ/2}$.
 3. WE# LOW time must be limited to t_{CEM} (8 μ s).

Table 11: Load Configuration Register Timing Requirements

Description	Symbol	-70		Units
		Min	Max	
Address setup time	t_{AS}	0		ns
Address valid to end of write	t_{AW}	70		ns
Chip deselect to ZZ# LOW	t_{CDZZ}	5		ns
Chip enable to end of write	t_{CW}	70		ns
Write cycle time	t_{WC}	70		ns
Write pulse width	t_{WP}	40		ns
Write recovery time	t_{WR}	0		ns
ZZ# LOW to WE# LOW	t_{ZZWE}	10	500	ns

Table 12: Deep Power-Down Timing Requirements

Description	Symbol	-70		Units
		Min	Max	
Chip deselect to ZZ# LOW	t_{CDZZ}	5		ns
Deep power-down recovery	t_R	150		μ s
Minimum ZZ# pulse width	$t_{ZZ}(\text{MIN})$	10		μ s

Timing Diagrams

Figure 16: Power-Up Initialization Period

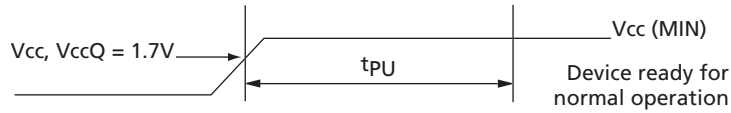

Table 13: Initialization Timing Parameters

Parameter	Symbol	-70		Units
		Min	Max	
Initialization period (required before normal operations)	t_{PU}		150	μs

Figure 17: Load Configuration Register

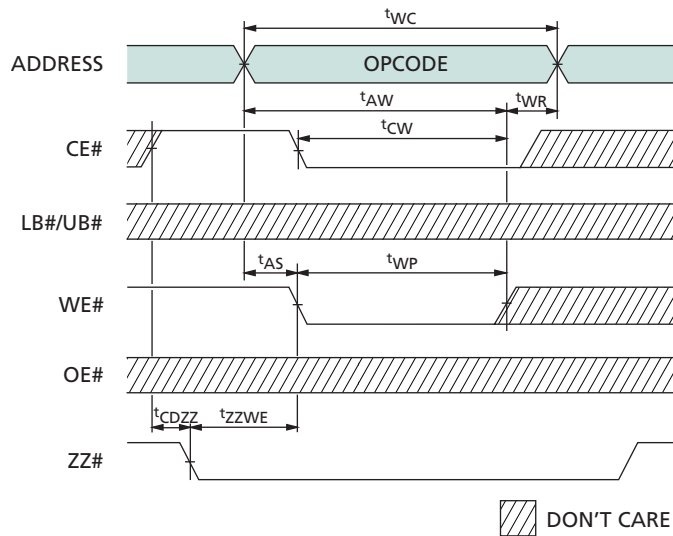

Figure 18: Deep Power-Down – Entry/Exit

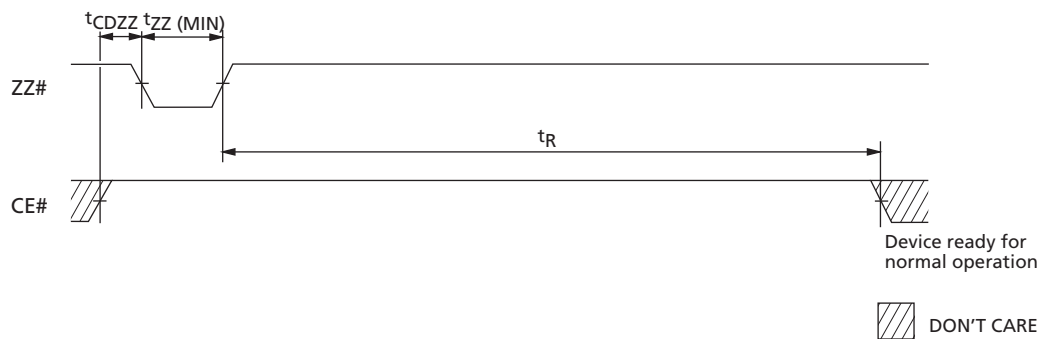

Figure 19: Single READ Operation (WE# = VIH)

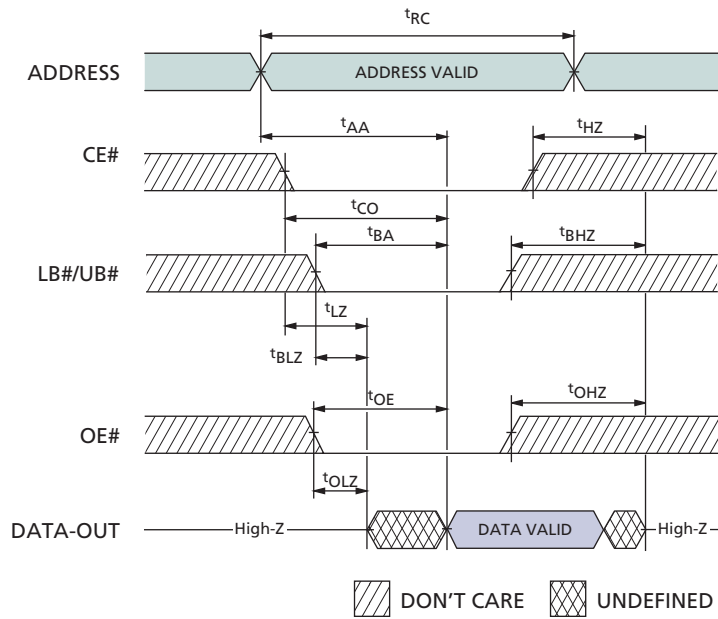

Figure 20: Page Mode READ Operation (WE# = VIH)

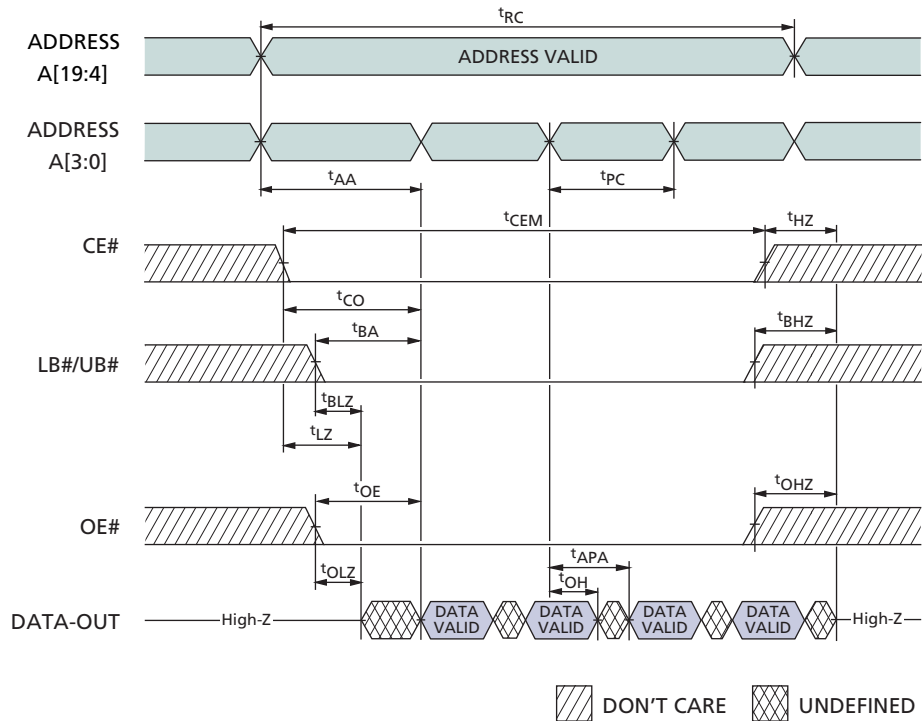

Figure 21: WRITE Cycle (WE# Control)

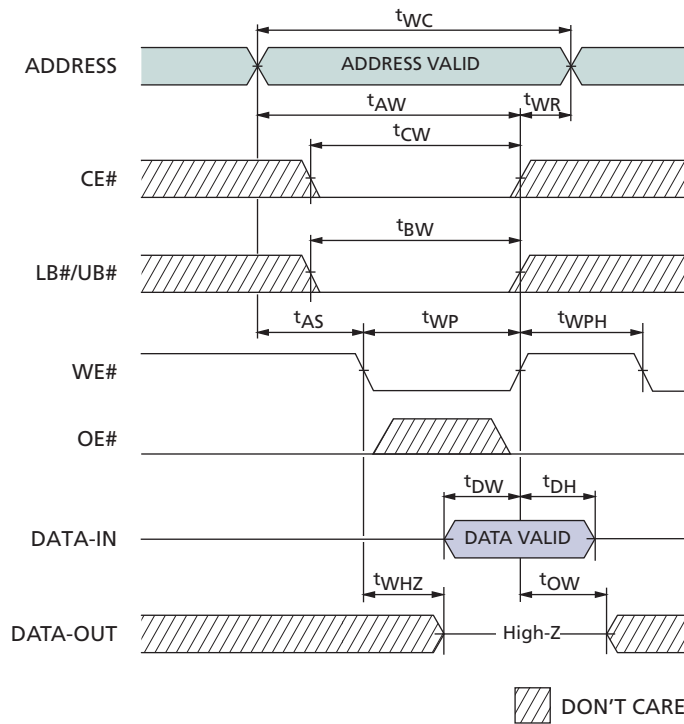

Figure 22: WRITE Cycle (CE# Control)

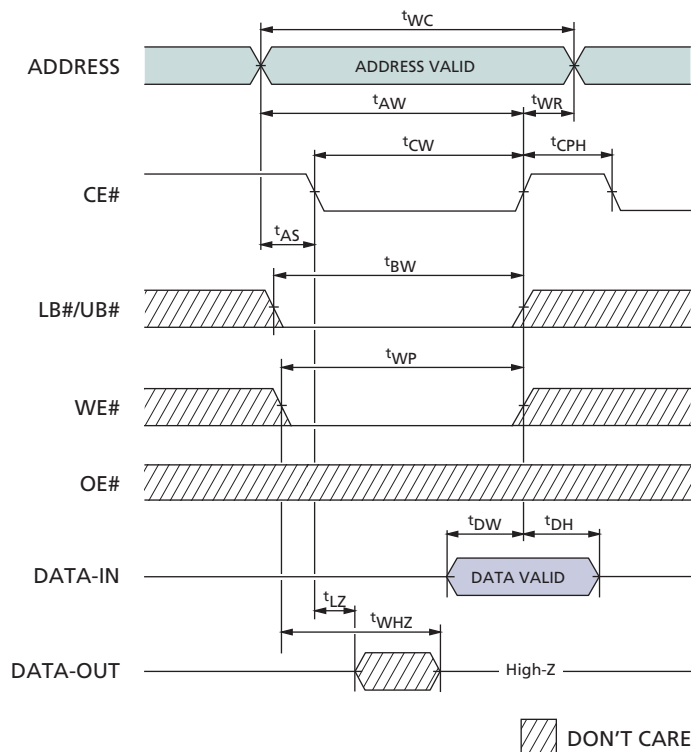
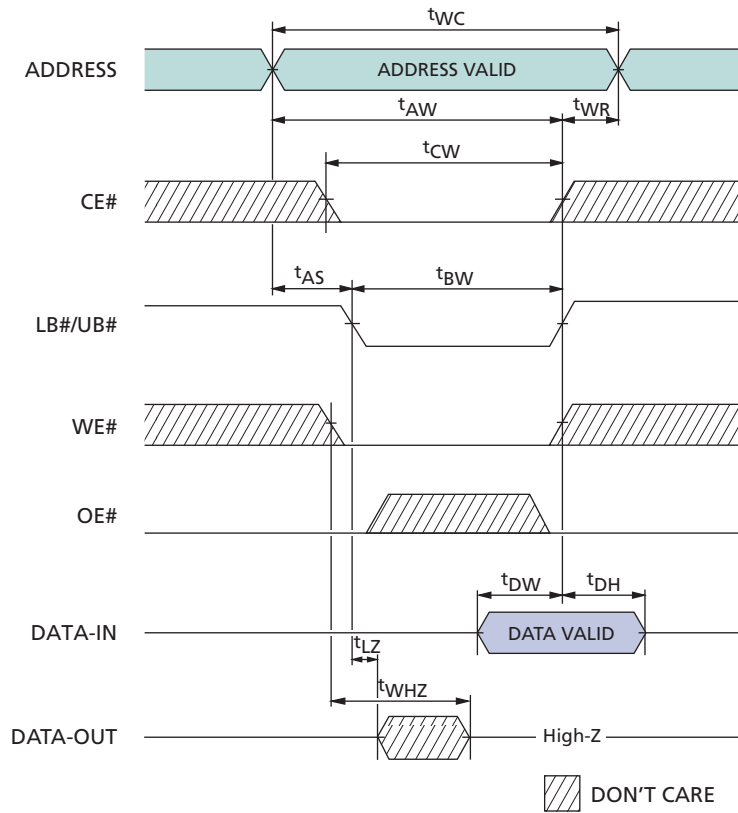
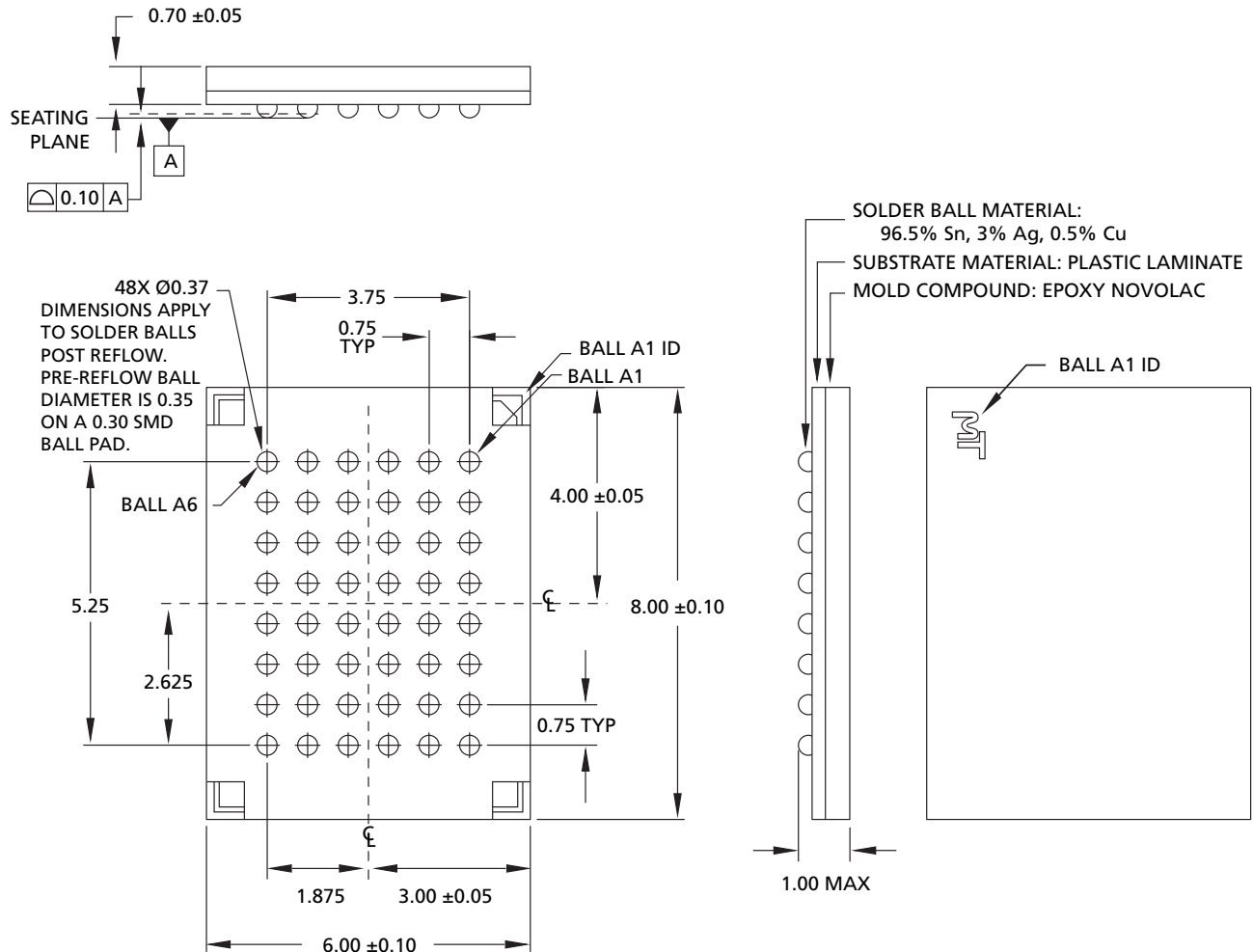

Figure 23: WRITE Cycle (LB#/UB# Control)



Package Dimensions

Figure 24: 48-Ball VFBGA



- Notes: 1. All dimensions in millimeters, MAX/MIN or typical where noted.
 2. Package width and length do not include mold protrusion; allowable mold protrusion is 0.25mm per side.
 3. The MT45W1MW16PD uses "green" packaging.



8000 S. Federal Way, P.O. Box 6, Boise, ID 83707-0006, Tel: 208-368-3900
 prodmktg@micron.com www.micron.com Customer Comment Line: 800-932-4992

Micron, the M logo, and the Micron logo are trademarks of Micron Technology, Inc. CellularRAM is a trademark of Micron Technology, Inc. inside the U.S. and a trademark of Qimonda AG outside the U.S. All other trademarks are the property of their respective owners. This data sheet contains minimum and maximum limits specified over the complete power supply and temperature range for production devices. Although considered final, these specifications are subject to change, as further product development and data characterization sometimes occur.



Revision History

Rev. F, Production	04/08
<ul style="list-style-type: none">• Updated Figure 10 and Figure 11 on page 15 and added the associated notes• Changed ^tPU from a MIN to MAX value in Table 13 on page 24.	
Rev. E, Production	02/08
<ul style="list-style-type: none">• Updated I/O voltage range from 3.3V MAX to 3.6V MAX	
Rev. D, Production	02/06
Rev. C, Preliminary	01/06
<ul style="list-style-type: none">• Updated document designator to Preliminary• Deleted Tables 13–20	
Rev. B	11/05
<ul style="list-style-type: none">• Updated “TBD” standby values	
Rev. A	08/05
<ul style="list-style-type: none">• Initial release; Advance	

Looking for pricing, stock, or lifecycle information?

Click below to explore more details on WIN SOURCE:

- ⊖ [View MT45W1MW16PDGA-70 IT on WIN SOURCE](#)
- ⊖ [Micron Technology Inc. Information](#)

Optimize Your Supply Chain with WIN SOURCE Solutions

- ✓ Global Sourcing Solution
- ✓ Obsolete Management
- ✓ Cost Control Management
- ✓ Shortage Management
- ✓ Alternative Solution
- ✓ Excess Inventory Management